

Test Report No.: 24010301-01-RF-US-01

## FCC Part 15, Subpart C Test Report

FCC ID: ARS-86BDL4152E

Applicant: TOP VICTORY ELECTRONICS (TAIWAN) CO., LTD.

Address: 10F., No. 230, Liancheng Rd., Zhonghe Dist., New Taipei City 23553,  
Taiwan

Manufacturer: TOP VICTORY ELECTRONICS (TAIWAN) CO., LTD.

Address: 10F., No. 230, Liancheng Rd., Zhonghe Dist., New Taipei City 23553,  
Taiwan

Product(s): LCD Monitor (with Android function)

Brand(s): Philips

Test Model(s): 86BDL4152E

Series Model(s): N/A

Test Date: Jan. 11, 2024~ Jan. 31, 2024

Issued Date: Feb. 02, 2024

Issued By: Hwa-Hsing (Dongguan) Testing Co., Ltd.

Address: No.101, Building N1, Yuyuan 2 Road, Yuyuan Industrial Park, HuangJiang  
Town, Dongguan City, People's Republic of China

Test Firm Registration No.: 915896

Designation No.: CN1255

Standards: FCC Part 15, Subpart C, Section 15.225

The above equipment has been tested by **Hwa-Hsing (Dongguan) Testing Co., Ltd.**, and found compliance with the requirement of the above standards. The test record, data evaluation & Equipment Under Test (EUT) configurations represented herein are true and accurate accounts of the measurements of the sample's EMC characteristics under the conditions specified in this report.

Prepared by :

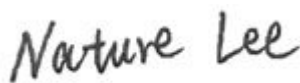

Nature Lee

Reviewed by :



Dragon Long

Approved by :



Scott He

"This report is for your exclusive use. Any copying or replication of this report to or for any other person or entity, or use of our name or trademark, is permitted only with our prior written permission. This report sets forth our findings solely with respect to the test samples identified herein. Our report includes all the tests requested by you and the results thereof based upon the information that you provided to us. The report would be invalid without specific stamp of test institute and the signatures of tester and approver."

Lab: [Hwa-Hsing \(Dongguan\) Testing Co., Ltd.](#)Address: [No.101, Building N1, Yuyuan 2 Road, Yuyuan Industrial  
Park, HuangJiang Town, Dongguan City, People's Republic  
of China](#)Tel: [0769-83078199](#)Web.: [www.hwa-hsing.com](#)E-Mail: [customerservice.dg@hwa-hsing.com](mailto:customerservice.dg@hwa-hsing.com)

Release

[Ver. 1.5](#)

## Table of Contents

<b>Release Control Record</b> .....	<b>3</b>
<b>1 Summary of Test Results</b> .....	<b>4</b>
1.1 Measurement Uncertainty .....	4
<b>2 General Information</b> .....	<b>5</b>
2.1 General Description of EUT .....	5
2.2 Description of Test Modes .....	5
2.3 Test Mode Applicability and Tested Channel Detail .....	6
2.4 Description of Support Units .....	7
<b>3 Test Types and Results</b> .....	<b>8</b>
3.1 Conducted Emission Measurement .....	8
3.1.1 Limits of Conducted Emission Measurement .....	8
3.1.2 Test Instruments .....	8
3.1.3 Test Procedures .....	9
3.1.4 Test Setup .....	9
3.1.5 EUT Operating Condition .....	9
3.1.6 Deviation from Test Standard .....	9
3.1.7 Test Results .....	10
3.2 Radiated Emission And Bandedge Measurement .....	12
3.2.1 Limits Of Radiated Emission And Bandedge Measurement .....	12
3.2.2 Test Instruments .....	13
3.2.3 Test Procedures .....	13
3.2.4 Deviation From Test Standard .....	14
3.2.5 Test Setup .....	15
3.2.6 EUT Operating Conditions .....	16
3.2.7 Test Results .....	16
3.3 Frequency Tolerance .....	18
3.3.1 Limit Of Frequency Tolerance .....	18
3.3.2 Test Instruments .....	18
3.3.3 Test Procedures .....	19
3.3.4 Deviation From Test Standard .....	19
3.3.5 Test Setup .....	19
3.3.6 EUT Operating Conditions .....	19
3.3.7 Test Results .....	20
3.4 20db Bandwidth .....	21
3.4.1 Limits Of 20db Bandwidth .....	21
3.4.2 Test Instruments .....	21
3.4.3 Test Procedure .....	21
3.4.4 Deviation From Test Standard .....	21
3.4.5 Test Setup .....	21
3.4.6 EUT Operating Condition .....	21
3.4.7 Test Results .....	22
<b>4 Pictures of Test Arrangements</b> .....	<b>23</b>
<b>Appendix – Information on the Testing Laboratories</b> .....	<b>24</b>

Test Report No.: 24010301-01-RF-US-01

**Release Control Record**

Issue No.	Description	Date Issued
24010301-01-RF-US-01	Original Release	Feb. 02, 2024

**1 Summary of Test Results**

The EUT has been tested according to the following specifications:

APPLIED STANDARD: FCC Part 15, Subpart C			
STANDARD SECTION	TEST TYPE AND LIMIT	RESULT	REMARK
15.207	AC Power Conducted Emission	PASS	Meet the requirement of limit.
15.225 (a)&(b)&(c)	The field strength of any emissions within the band	PASS	Meet the requirement of limit.
15.225 (d)	The field strength of any emissions appearing outside of the 13.110-14.010 MHz band	PASS	Meet the requirement of limit.
15.225 (e)	Frequency tolerance	PASS	Meet the requirement of limit.
15.215 (c)	20dB Bandwidth	PASS	Meet the requirement of limit.
15.203	Antenna Requirement	PASS	No antenna connector is used.

**1.1 Measurement Uncertainty**

Where relevant, the following measurement uncertainty levels have been estimated for tests performed on the EUT as specified in CISPR 16-4-2:

The listed uncertainties are the worst-case uncertainty for the entire range of measurement. Please note that the uncertainty values are provided for informational purposes only and are not used in determining the PASS/FAIL results.

Measurement	Frequency	Expanded Uncertainty (k=2) (±)
Radiated Emissions up to 1 GHz	9KHz ~ 30MHz	2.16 dB
	30MHz ~ 1000MHz	3.47 dB
Conducted emissions	9kHz~30MHz	2.70dB

Note: This uncertainty represents an expanded uncertainty expressed at approximately the 95% confidence level using a coverage factor of k = 2.

**2 General Information**

**2.1 General Description of EUT**

Product(s)	LCD Monitor (with Android function)
Test Model(s)	86BDL4152E
Series Model(s)	N/A
FCC ID	ARS-86BDL4152E
Normal Voltage	100-240V~ 50/60Hz 5.2A
Modulation Technology	NFC
Modulation Type	ASK
Operating Frequency	13.56MHz
Number Of Channel	1
Maximum Output Power	57.52dBuV/m (Measured Max.)
Antenna Type	FPC antenna
Antenna Connector	I-PEX
I/O Ports	Refer to user's manual
Data Cable Supplied	See note 3

Note:

1. The above EUT information is declared by manufacturer and for more detailed features description, please refer to the manufacturer's specifications or user's manual.
2. Please refer to the EUT photo document (Reference No.: 24010301-01-02/-03) for detailed product photo.
3. Data Cable Supplied List:

Item	Length(m)	Number(pcs)
AC cable	3.0	1
HDMI cable	3.0	2
USB2.0 A to B cable	3.0	1
USB2.0 A to B cable	1.8	1
VGA cable	4.0	1
RS232 cable	3.0	1
RS232 cable	1.8	1
DVI cable	1.8	1
DVI cable	1.5	1
DVI to VGA cable	1.8	1
DVI to VGA cable	1.5	1

**2.2 Description of Test Modes**

The EUT only have one channel:

CHANNEL	FREQUENCY (MHz)
1	13.56

### 2.3 Test Mode Applicability and Tested Channel Detail

Pre-Scan has been conducted to determine the worst-case mode from all possible combinations between available modulations, data rates, XYZ axis and antenna ports

The worst case was found when positioned on X axis for radiated emission. Following channel(s) was (were) selected for the final test as listed below:

EUT CONFIGURE MODE	APPLICABLE TO				DESCRIPTION
	RE	FT	PLC	BW	
A	√	√	√	√	AC120V/60Hz

Where RE: Radiated Emission

PLC: Power Line Conducted Emission

FT: Frequency tolerance

BW: 20dB Bandwidth

### RADIATED EMISSION TEST:

- Pre-Scan has been conducted to determine the worst-case mode from all possible combinations between available modulations, XYZ axis, antenna ports (if EUT with antenna diversity architecture) and packet type.
- Following channel(s) was (were) selected for the final test as listed below.

EUT CONFIGURE MODE	TESTED CHANNEL	TESTED FREQUENCY (MHZ)	MODULATION TYPE	AXIS
A	1	13.56	ASK	X

### FREQUENCY TOLERANCE:

- This item includes all test value of each mode, but only includes spectrum plot of worst value of each mode.
- Pre-Scan has been conducted to determine the worst-case mode from all possible combinations between available modulations, antenna ports (if EUT with antenna diversity architecture), and packet types.
- Following channel(s) was (were) selected for the final test as listed below.

EUT CONFIGURE MODE	TESTED CHANNEL	TESTED FREQUENCY (MHZ)	MODULATION TYPE	AXIS
A	1	13.56	ASK	X

## POWER LINE CONDUCTED EMISSION TEST:

- This item includes all test value of each mode, but only includes spectrum plot of worst value of each mode.
- Pre-Scan has been conducted to determine the worst-case mode from all possible combinations between available modulations, antenna ports (if EUT with antenna diversity architecture), and packet types.
- Following channel(s) was (were) selected for the final test as listed below.

EUT CONFIGURE MODE	TESTED CHANNEL	TESTED FREQUENCY (MHZ)	MODULATION TYPE	AXIS
A	1	13.56	ASK	X

## 20dB BANDWIDTH:

- This item includes all test value of each mode, but only includes spectrum plot of worst value of each mode.
- Pre-Scan has been conducted to determine the worst-case mode from all possible combinations between available modulations, antenna ports (if EUT with antenna diversity architecture), and packet types.
- Following channel(s) was (were) selected for the final test as listed below.

EUT CONFIGURE MODE	TESTED CHANNEL	TESTED FREQUENCY (MHZ)	MODULATION TYPE	AXIS
A	1	13.56	ASK	X

## TEST CONDITION:

APPLICABLE TO	ENVIRONMENTAL CONDITIONS	TEST VOLTAGE (SYSTEM)	TESTED BY
RE	21deg. C, 63%RH	AC120V/60Hz	Dragon
FT	25deg. C, 60%RH	AC120V/60Hz	Dragon
PLC	25deg. C, 55%RH	AC120V/60Hz	Dragon
BW	25deg. C, 60%RH	AC120V/60Hz	Dragon

### 2.4 Description of Support Units

The EUT has been tested as an independent unit together with other necessary accessories or support units. The following support units or accessories were used to form a representative test configuration during the tests.

No.	Product	Brand	Model No.	Serial No.
1.	Mobile phone	HUWWEI	Mate30 Pro	RPTGK2151800005

**3 Test Types and Results****3.1 Conducted Emission Measurement**

## 3.1.1 Limits of Conducted Emission Measurement

Frequency (MHz)	Conducted Limit (dBuV)	
	Quasi-peak	Average
0.15 - 0.5	66 - 56	56 - 46
0.50 - 5.0	56	46
5.0 - 30.0	60	50

- Note: 1. The lower limit shall apply at the transition frequencies.  
2. The limit decreases in line with the logarithm of the frequency in the range of 0.15 to 0.50MHz.

## 3.1.2 Test Instruments

Equipment	Manufacturer	Model No.	Serial No.	Next Cal.
EMI Test Receiver	Rohde&Schwarz	ESR 7	101962	2024-12-17
Artificial Mains Network	Rohde&Schwarz	ENV216	3560.6550.15	2024-12-17
Test software	FARAD	EZ_EMV V1.1.4.2	N/A	N/A
Broadcast test system	R&S	SFU	100410	2024-08-06

- Note: 1. The calibration interval of the above test instruments is 12 months.  
2. The test was performed in Shielded Room.



Test Report No.: 24010301-01-RF-US-01

### 3.1.3 Test Procedures

- a. The EUT was placed 0.4 meters from the conducting wall of the shielded room with EUT being connected to the power mains through a line impedance stabilization network (LISN). Other support units were connected to the power mains through another LISN. The two LISNs provide 50 ohm/ 50uH of coupling impedance for the measuring instrument.
- b. Both lines of the power mains connected to the EUT were checked for maximum conducted interference.
- c. The frequency range from 150kHz to 30MHz was searched. Emission levels under (Limit – 20dB) was not recorded.

**Note:** All modes of operation were investigated and the worst-case emissions are reported.

### 3.1.4 Test Setup

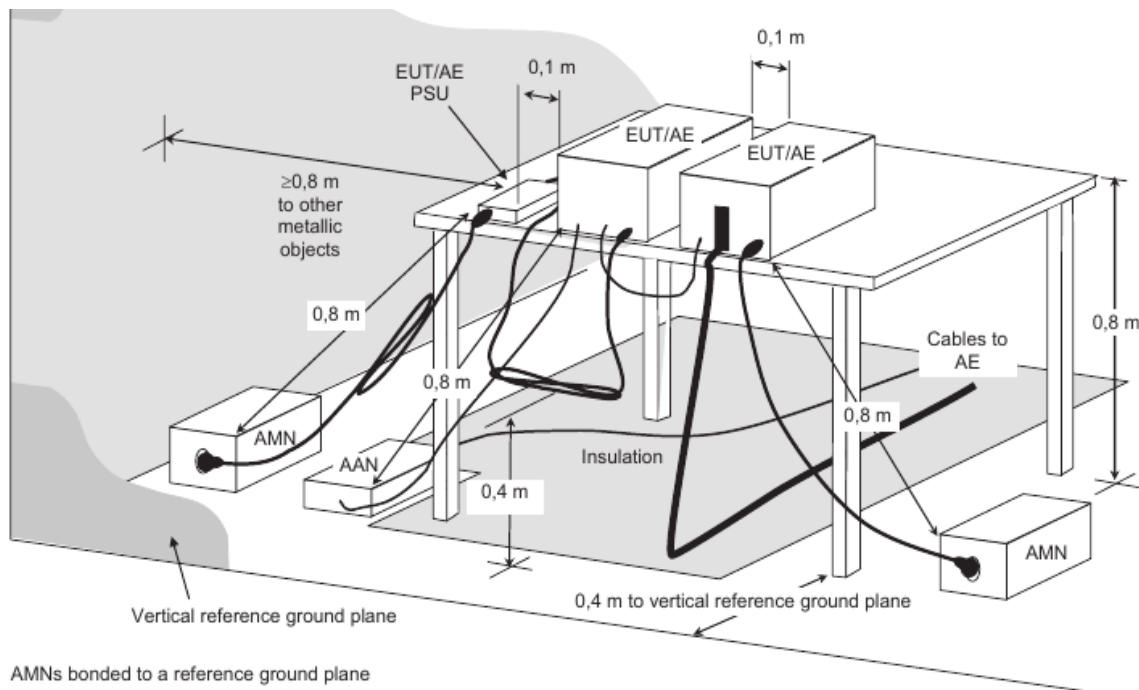

For the actual test configuration, please refer to the attached file (Test Setup Photo).

### 3.1.5 EUT Operating Condition

Set the EUT under transmission condition continuously at specific channel frequency.

### 3.1.6 Deviation from Test Standard

No deviation.

### 3.1.7 Test Results

Frequency Range	150kHz ~ 30MHz	Detector Function & Resolution bandwidth	Quasi-Peak (QP) / Average (AV), 9kHz
-----------------	----------------	--	--------------------------------------

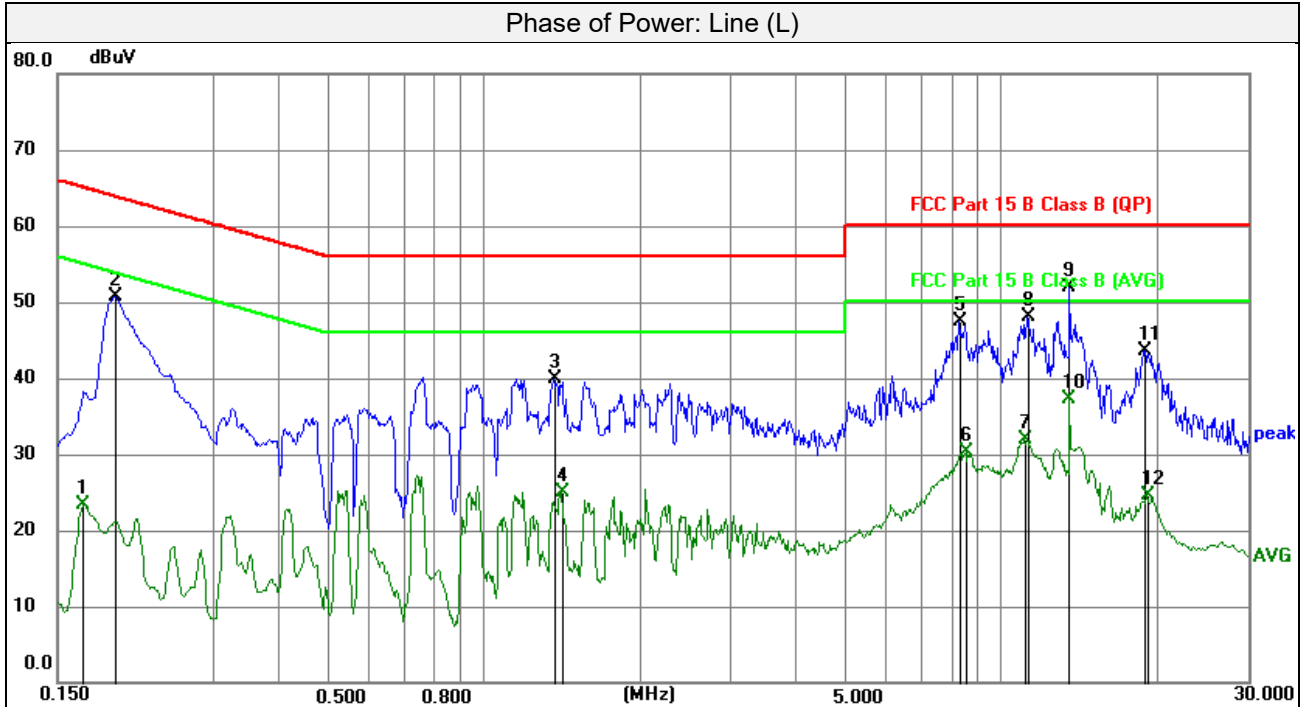

No.	Frequency (MHz)	Reading (dBuV)	Correction Factor (dB)	Emission Level (dBuV)	Limit (dBuV)	Margin (dB)	Remark
1	0.1680	13.24	10.17	23.41	55.06	-31.65	AVG
2	0.1928	40.63	10.15	50.78	63.92	-13.14	peak
3	1.3673	29.90	10.05	39.95	56.00	-16.05	peak
4	1.4123	14.97	10.06	25.03	46.00	-20.97	AVG
5	8.3220	37.44	10.05	47.49	60.00	-12.51	peak
6	8.5470	20.15	10.06	30.21	50.00	-19.79	AVG
7	11.1143	21.84	10.14	31.98	50.00	-18.02	AVG
8	11.2448	37.95	10.14	48.09	60.00	-11.91	peak
9	13.5600	41.81	10.22	52.03	60.00	-7.97	peak
10	13.5600	27.11	10.22	37.33	50.00	-12.67	AVG
11	18.8205	33.28	10.36	43.64	60.00	-16.36	peak
12	19.1468	14.17	10.36	24.53	50.00	-25.47	AVG

#### Remarks:

1. Q.P. and AV. are abbreviations of quasi-peak and average individually.
2. The emission levels of other frequencies were very low against the limit.
3. Margin value = Emission level - Limit value
4. Correction factor = Insertion loss + Cable loss
5. Emission Level = Correction Factor + Reading Value.

Frequency Range	150kHz ~ 30MHz	Detector Function & Resolution bandwidth	Quasi-Peak (QP) / Average (AV), 9kHz
-----------------	----------------	--	--------------------------------------

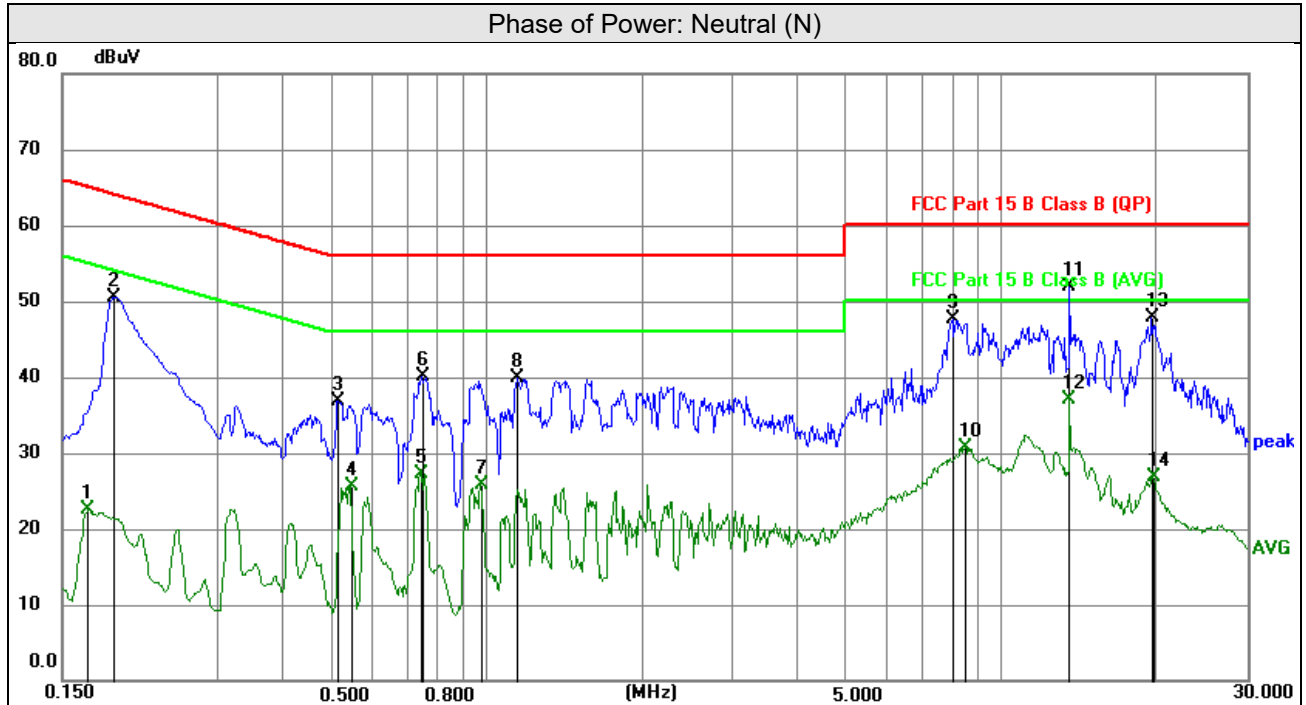

No.	Frequency	Reading	Correct Factor	Emission Level	Limit	Margin	Remark
	(MHz)	(dBuV)	dB	(dBuV)	(dBuV)	(dB)	Detector
1	0.1680	12.34	10.17	22.51	55.06	-32.55	AVG
2	0.1883	40.45	10.15	50.60	64.11	-13.51	peak
3	0.5144	26.76	10.11	36.87	56.00	-19.13	peak
4	0.5437	15.42	10.11	25.53	46.00	-20.47	AVG
5	0.7462	17.16	10.09	27.25	46.00	-18.75	AVG
6	0.7485	30.06	10.09	40.15	56.00	-15.85	peak
7	0.9780	15.76	10.05	25.81	46.00	-20.19	AVG
8	1.1512	29.74	10.06	39.80	56.00	-16.20	peak
9	8.0588	37.66	10.05	47.71	60.00	-12.29	peak
10	8.5020	20.65	10.07	30.72	50.00	-19.28	AVG
11	13.5600	41.70	10.25	51.95	60.00	-8.05	peak
12	13.5600	26.69	10.25	36.94	50.00	-13.06	AVG

**Remarks:**

1. Q.P. and AV. are abbreviations of quasi-peak and average individually.
2. The emission levels of other frequencies were very low against the limit.
3. Margin value = Emission level - Limit value
4. Correction factor = Insertion loss + Cable loss
5. Emission Level = Correction Factor + Reading Value.

**3.2 Radiated Emission And Bandedge Measurement**

3.2.1 Limits Of Radiated Emission And Bandedge Measurement

The field strength of any emissions shall not exceed the following limits:

- (a) 15.848mV/m(84dBuV/m) at 30m, within the band 13.553-13.567 MHz;
- (b) 334uV/m(50.5dBuV/m) at 30m, within the band 13.410-13.553 MHz and 13.567-13.710MHz;
- (c) 106uV/m(40.5dBuV/m) at 30m, within the band 13.110-13.410 MHz and 13.710-14.010MHz;

The field strength of any emissions appearing outside of the 13.110-14.010 MHz band shall not exceed the general radiated emission limits in § 15.209.

FREQUENCIES (MHz)	FIELD STRENGTH (microvolts/meter)	MEASUREMENT DISTANCE (meters)
0.009 ~ 0.490	2400/F(kHz)	300
0.490 ~ 1.705	24000/F(kHz)	30
1.705 ~ 30.0	30	30
30 ~ 88	100	3
88 ~ 216	150	3
216 ~ 960	200	3
Above 960	500	3

**NOTE:**

1. The lower limit shall apply at the transition frequencies.
2. Emission level (dBuV/m) = 20 log Emission level (uV/m).
3. As shown in 15.35(b), for frequencies above 1000MHz, the field strength limits are based on average detector, however, the peak field strength of any emission shall not exceed the maximum permitted average limits, specified above by more than 20dB under any condition of modulation.
4. The measured field strength was extrapolated to distance 30 meters, using the formula that the limit of field strength varies as the inverse distance square (40dB per decade of distance)

Example:

$$\begin{aligned}
 13.56\text{MHz} &= 15848\text{uV/m} && 30\text{m} \\
 &= 84\text{dBuV/m} && 30\text{m} \\
 &= 84+20\log(30/3)^2 && 3\text{m} \\
 &= 124\text{dBuV/m}
 \end{aligned}$$

## 3.2.2 Test Instruments

(9kHz-30MHz, 966 Chamber):

Equipment	Manufacturer	Model No.	Serial No.	Next Cal.
EMI Test Receiver (9kHz~7GHz)	Rohde&Schwarz	ESPI 7	101978	2024-12-17
Loop antenna (9kHz~30MHz)	TESEQ	HLA 6121	56735	2024-05-05
3m Semi-anechoic Chamber	MAORUI	9m*6m*6m	HS-2018037	2026-03-12**
Attenuator	R&S	TS2GA-6dB	18101101	N/A
Test software	EZ	EZ EMC V1.1.4.2	N/A	N/A

(30MHz-1GHz, 966 Chamber):

Equipment	Manufacturer	Model No.	Serial No.	Next Cal.
EMI Test Receiver (9kHz~7GHz)	Rohde&Schwarz	ESPI 7	101978	2024-12-17
Broadband antenna (25MHz~2500MHz)	Schwarzbeck	VULB 9168	937	2024-08-18
3m Semi-anechoic Chamber	MAORUI	9m*6m*6m	HS-2018037	2026-03-12**
Signal Amplifier (30MHz~1000MHz)	Com-power	PAM-103	18020051	2024-08-06
Attenuator	R&S	TS2GA-6dB	18101101	N/A
Test software	EZ	EZ EMC V1.1.4.2	N/A	N/A

**NOTE:**

1. The test was witness in 966 Chamber and RF Oven room in in Hwa-Hsing (Dongguan) Testing Co., Ltd.
2. The calibration interval of the above test instruments is 12/24\*/36\*\* months and the calibrations are traceable to GRGT/CHINA.

## 3.2.3 Test Procedures

- a. The EUT was placed on the top of a rotating table 0.8 meters above the ground at a 3&10 meter semi-anechoic chamber. The table was rotated 360 degrees to determine the position of the highest radiation.
- b. The EUT was set 3 meters away from the interference-receiving antenna, which was mounted on the top of a variable-height antenna tower.
- c. The antenna is a broadband antenna, and its height is varied from one meter to four meters above the ground to determine the maximum value of the field strength. Both horizontal and vertical polarizations of the antenna are set to make the measurement.
- d. For each suspected emission, the EUT was arranged to its worst case and then the antenna was tuned to heights from 1 meter to 4 meters and the rotatable table was turned from 0 degrees to 360 degrees to find the maximum reading.
- e. The test-receiver system was set to quasi-peak detect function and specified bandwidth with maximum hold mode when the test frequency is below 1 GHz.

Test Report No.: 24010301-01-RF-US-01

- f. During the test, each emission was maximized by: having the EUT continuously working, investigated all operating modes, rotated about all 3 axis (X, Y & Z) and considered typical configuration to obtain worst position, manipulating interconnecting cables, For battery operated equipment, the equipment tests shall be perform using fresh batteries. The turntable was rotated to maximize the emission level.
- g. For below 30MHz, a loop antenna with its vertical plane is place 3m from the EUT and rotated about its vertical axis for maximum response at each azimuth about the EUT. And the centre of the loop shall be 1m above the ground.

**NOTE:**

1. The resolution bandwidth and video bandwidth of test receiver/spectrum analyzer is 120kHz for Quasi-peak detection at frequency below 1GHz.
2. The resolution bandwidth of test receiver/spectrum analyzer is 1 MHz and video bandwidth is 3MHz for Peak detection at frequency above 1GHz.
3. All modes of operation were investigated and the worst-case emissions are reported.

#### 3.2.4 Deviation From Test Standard

No deviation.

## 3.2.5 Test Setup

Radiated emission below 30MHz:

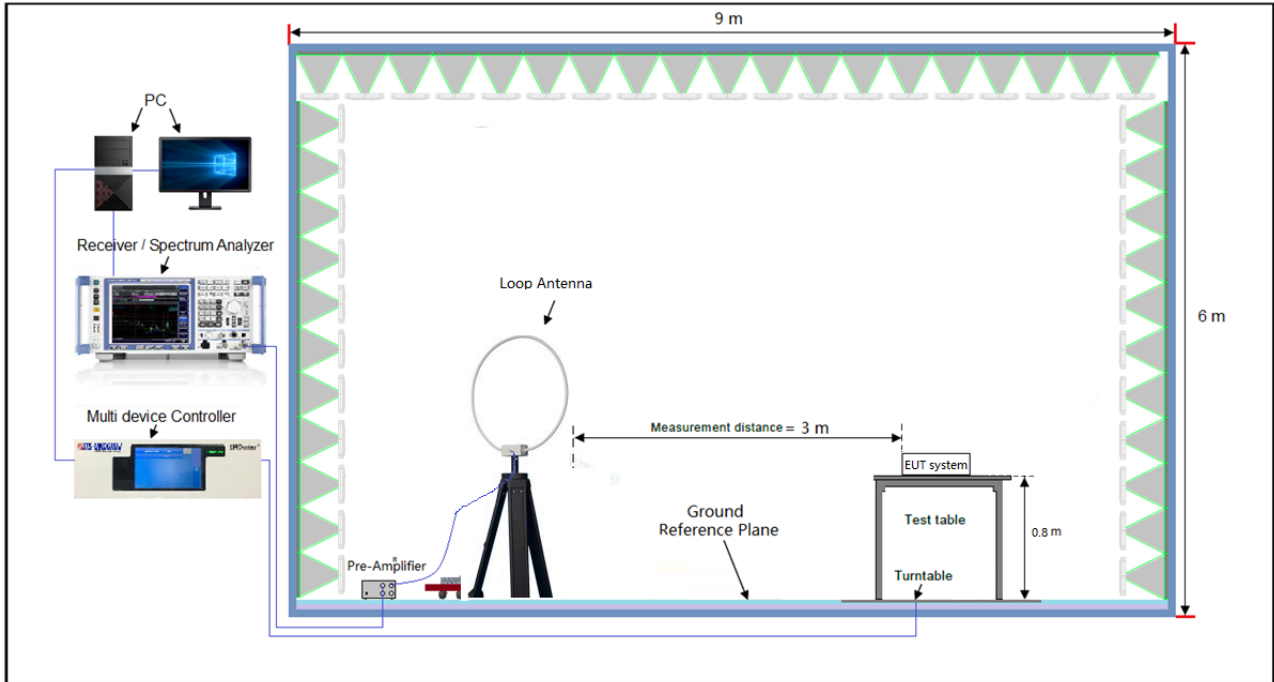

Frequency Range below 1GHz:

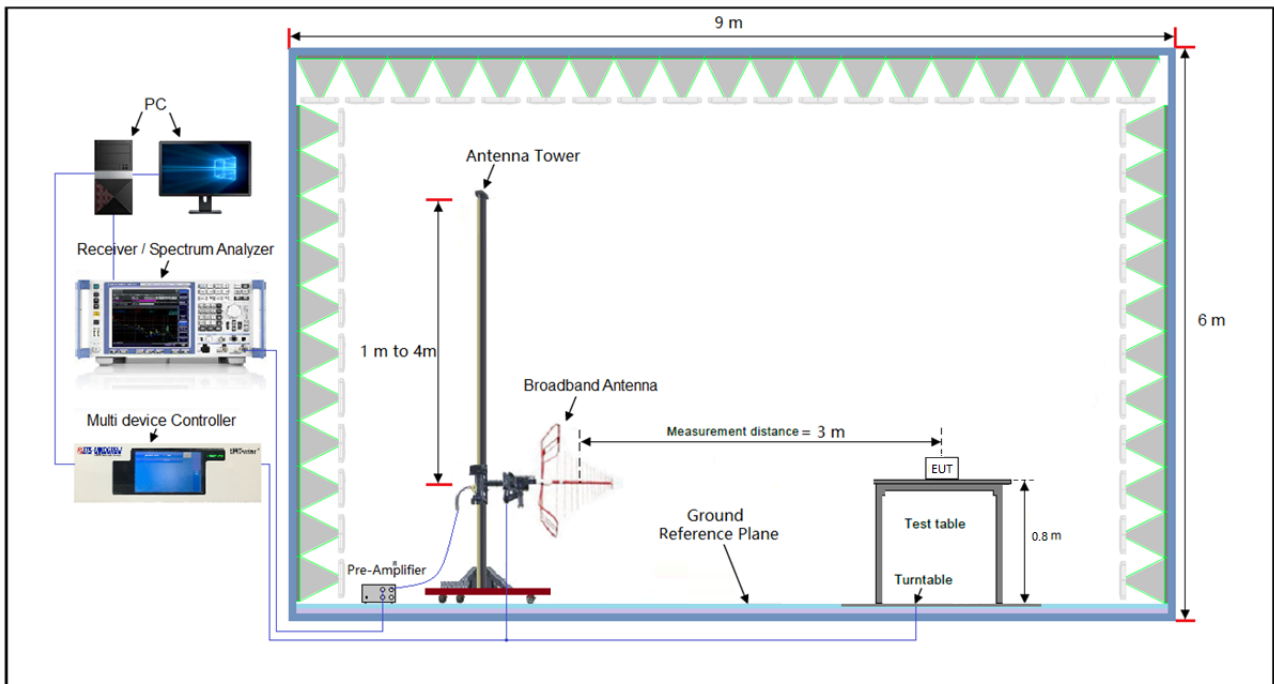

**Note:** For the actual test configuration, please refer to the attached file (Test Setup Photo).

### 3.2.6 EUT Operating Conditions

Set the EUT under transmission condition continuously at specific channel frequency.

### 3.2.7 Test Results

#### FIELD STRENGTH (BELOW 30MHZ AT 3M)

No.	Freq. (MHz)	Emission Level (dBuV/m)	Polarity (0° / 90°)	Limit (dBuV/m)	Margin (dB)
1	*13.56(QP)	56.45	0°	124.0	-67.55
2	27.12(QP)	21.56	0°	69.5	-47.94
3	*13.56(QP)	57.52	90°	124.0	-66.48
4	27.12(QP)	24.42	90°	69.5	-45.08

- REMARKS:**
- The other emission levels were very low against the limit.
  - Margin value = Emission level – Limit value.
  - " \* ": Fundamental frequency.
  - For the test results, both 0° and 90° polarizations of the antenna are set to make the measurement, but only the worst case was shown in test report.

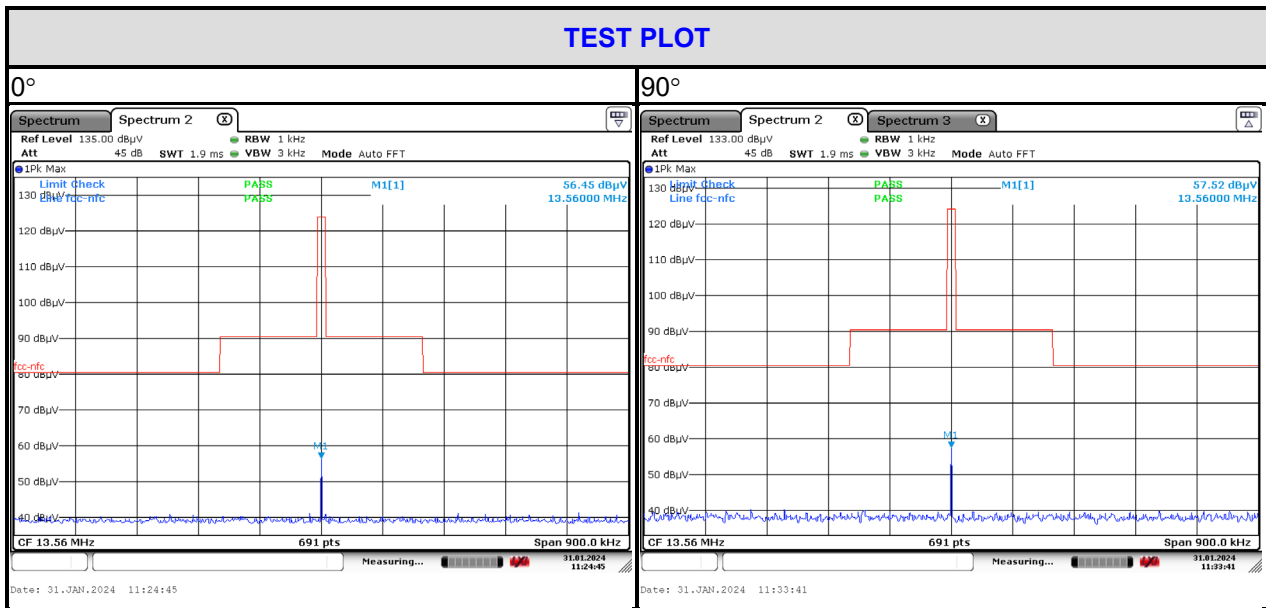



**BELOW 1GHz WORST-CASE DATA:**

<b>CHANNEL</b>	Channel 1	<b>DETECTOR FUNCTION</b>	Quasi-Peak (QP)
<b>FREQUENCY RANGE</b>	9KHz ~ 1GHz		

SPURIOUS EMISSION LEVEL AT 3M				
Frequency (MHz)	Antenna Polarization	Level (dBuV/m)	Limit (dBuV/m)	Margin (dB)
2.4312	H	2.41	69.50	-67.09
11.3223	H	6.54	69.50	-62.96
57.1914	H	28.95	40.00	-11.05
158.1123	H	36.72	43.50	-6.78
210.7860	H	38.28	43.50	-5.22
372.0045	H	35.41	46.00	-10.59
528.2458	H	35.92	46.00	-10.08
875.2470	H	38.18	46.00	-7.82

SPURIOUS EMISSION LEVEL AT 3M				
Frequency (MHz)	Antenna Polarization	Level (dBuV/m)	Limit (dBuV/m)	Margin (dB)
3.2913	V	1.33	69.50	-68.17
10.0932	V	5.82	69.50	-63.68
135.5062	V	31.40	43.50	-12.10
160.3456	V	39.02	43.50	-4.48
210.7860	V	38.44	43.50	-5.06
369.4047	V	41.32	46.00	-4.68
528.2458	V	38.78	46.00	-7.22
629.4772	V	39.81	46.00	-6.19

**REMARKS:**

1. The emission levels of other frequencies were less than 20dB margin against the limit.
2. Margin value = Emission level – Limit value.

**3.3 Frequency Tolerance**

## 3.3.1 Limit Of Frequency Tolerance

The frequency tolerance of the carrier signal shall be maintained within +/- 0.01% of the operating frequency over a temperature variation of -20 degrees to 50 degrees C at normal supply voltage, and for a variation in the primary supply voltage from 85% to 115% of the rated supply voltage at a temperature of 20 degrees C.

## 3.3.2 Test Instruments

Equipment	Manufacturer	Model No.	Serial No.	Next Cal.Date
Spectrum Analyzer	Rohde&Schwarz	FSV-40N	101783	2024-12-17
Power Meter 10Hz~18GHz	Tonscend	JS0806-2	188060126	2024-08-06
Humidity tester	Jingchuang	GSP-8A	CMA22B000592	2024-01-15
Humid & Temp Programmable Tester	GRT	GR-HWS1000	GR22021002	2024-03-12

**NOTE:**

1. The test was performed in RF Oven room.
2. The calibration interval of the above test instruments is 12 months and the calibrations are traceable to GRGT/CHINA..

Test Report No.: 24010301-01-RF-US-01

### 3.3.3 Test Procedures

- a) The EUT was placed inside the environmental test chamber and powered by nominal DC voltage.
- b) Turn the EUT on and couple its output to a spectrum analyzer.
- c) Turn the EUT off and set the chamber to the highest temperature specified.
- d) Allow sufficient time (approximately 30 min) for the temperature of the chamber to stabilize, turn the EUT on and measure the operating frequency after 2, 5, and 10 minutes.
- e) Repeat step c) and d) with the temperature chamber set to the lowest temperature.
- f) The test chamber was allowed to stabilize at +20 degree C for a minimum of 30 minutes. The supply voltage was then adjusted on the EUT from 85% to 115% and the frequency record.

### 3.3.4 Deviation From Test Standard

No deviation.

### 3.3.5 Test Setup

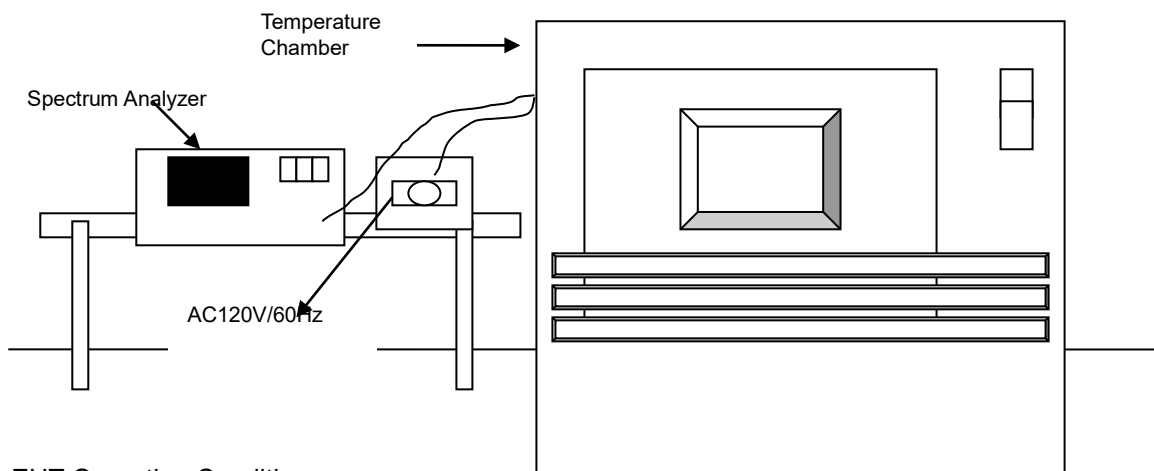

### 3.3.6 EUT Operating Conditions

Set the EUT under transmission condition continuously at specific channel frequency.

3.3.7 Test Results

FREQUENCY STABILITY VERSUS TEMP.									
TEMP. (°C)	POWER SUPPLY (V)	0 MINUTE		2 MINUTE		5 MINUTE		10 MINUTE	
		Measured Frequency	Frequency Drift	Measured Frequency	Frequency Drift	Measured Frequency	Frequency Drift	Measured Frequency	Frequency Drift
		(MHz)	%	(MHz)	%	(MHz)	%	(MHz)	%
50	120V/60Hz	13.55996	-0.00029	13.55997	-0.00022	13.55996	-0.00029	13.55996	-0.00029
40	120V/60Hz	13.56006	0.00044	13.56006	0.00044	13.56007	0.00052	13.56007	0.00052
30	120V/60Hz	13.56001	0.00007	13.56000	0.00000	13.56000	0.00000	13.56000	0.00000
20	120V/60Hz	13.56002	0.00015	13.56002	0.00015	13.56002	0.00015	13.56001	0.00007
10	120V/60Hz	13.56006	0.00044	13.56005	0.00037	13.56006	0.00044	13.56006	0.00044
0	120V/60Hz	13.56006	0.00044	13.56006	0.00044	13.56006	0.00044	13.56006	0.00044
-10	120V/60Hz	13.56003	0.00022	13.56002	0.00015	13.56003	0.00022	13.56003	0.00022
-20	120V/60Hz	13.56005	0.00037	13.56005	0.00037	13.56005	0.00037	13.56005	0.00037

FREQUENCY STABILITY VERSUS VOLTAGE									
TEMP. (°C)	POWER SUPPLY (V)	0 MINUTE		2 MINUTE		5 MINUTE		10 MINUTE	
		Measured Frequency	Frequency Drift	Measured Frequency	Frequency Drift	Measured Frequency	Frequency Drift	Measured Frequency	Frequency Drift
		(MHz)	%	(MHz)	%	(MHz)	%	(MHz)	%
20	102V/60Hz	13.56002	0.00015	13.56002	0.00015	13.56002	0.00015	13.56001	0.00007
	120V/60Hz	13.56002	0.00015	13.56002	0.00015	13.56002	0.00015	13.56001	0.00007
	138V/60Hz	13.56002	0.00015	13.56002	0.00015	13.56002	0.00015	13.56001	0.00007

Test Report No.: 24010301-01-RF-US-01

### 3.4 20db Bandwidth

#### 3.4.1 Limits Of 20db Bandwidth

The 20dB bandwidth shall be specified in operating frequency band.(13.11MHz – 14.01MHz)

#### 3.4.2 Test Instruments

Equipment	Manufacturer	Model No.	Serial No.	Next Cal.Date
Spectrum Analyzer	Rohde&Schwarz	FSV-40N	101783	2024-12-17
Power Meter 10Hz~18GHz	Tonscend	JS0806-2	188060126	2024-08-06
Humidity tester	Jingchuang	GSP-8A	CMA22B000592	2025-01-15

#### NOTE:

1. The test was performed in RF Oven room.
2. The calibration interval of the above test instruments is 12 months and the calibrations are traceable to GRGT/CHINA..

#### 3.4.3 Test Procedure

- a. Check the calibration of the measuring instrument using either an internal calibrator or a known signal from an external generator.
- b. Turn on the EUT and connect it to measurement instrument. Then set it to any one convenient frequency within its operating range. Set a reference level on the measuring instrument equal to the highest peak value.
- c. Measure the frequency difference of two frequencies that were attenuated 20dB from the reference level. Record the frequency difference as the emission bandwidth.

#### 3.4.4 Deviation From Test Standard

No deviation.

#### 3.4.5 Test Setup

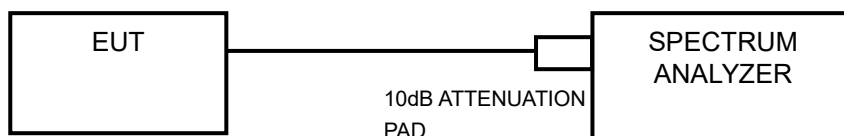

#### 3.4.6 EUT Operating Condition

The software provided by client to enable the EUT under transmission condition continuously.

Lab: [Hwa-Hsing \(Dongguan\) Testing Co., Ltd.](#)

Address: [No.101, Building N1, Yuyuan 2 Road, Yuyuan Industrial Park, HuangJiang Town, Dongguan City, People's Republic of China](#)

Tel: [0769-83078199](tel:0769-83078199)

Web.: [www.hwa-hsing.com](http://www.hwa-hsing.com)

E-Mail: [customerservice.dg@hwa-hsing.com](mailto:customerservice.dg@hwa-hsing.com)

Release

[Ver. 1.5](#)

### 3.4.7 Test Results

CHANNEL	CHANNEL FREQUENCY (MHz)	20dB BANDWIDTH (KHz)
1	13.56	25.47

Lower & Upper Test Frequency Point (MHz)	Test Frequency (MHz)	P/F
Lower	13.54726	PASS
Upper	13.57274	PASS

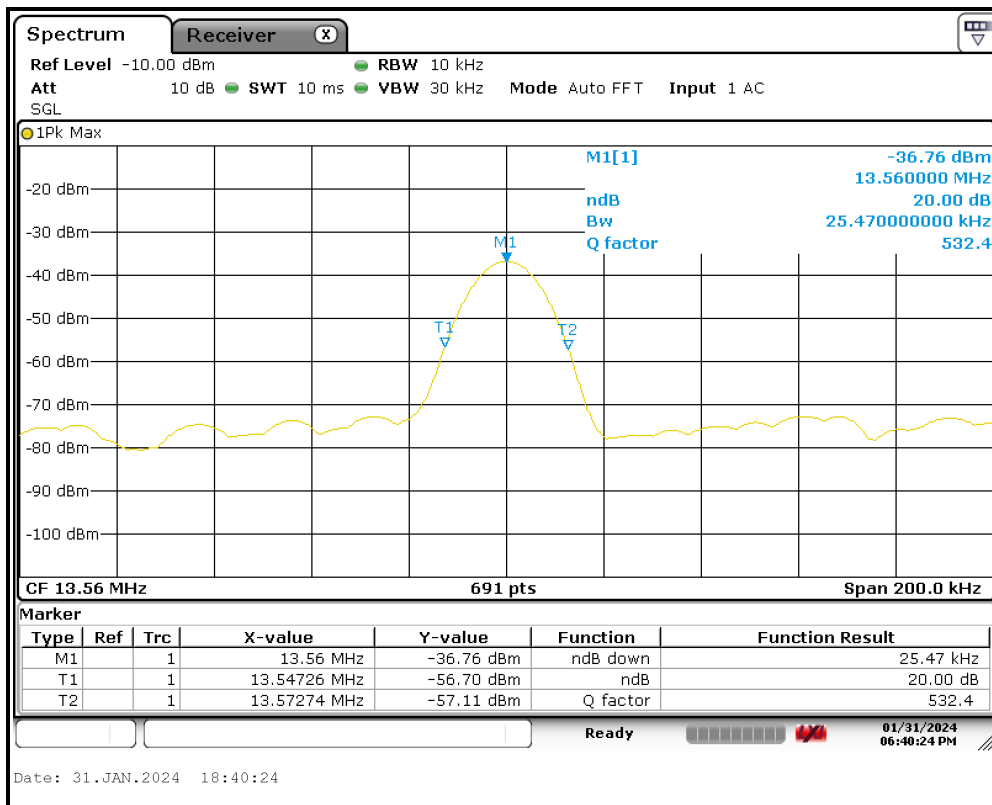

Test Report No.: 24010301-01-RF-US-01

**4 Pictures of Test Arrangements**

Please refer to the attached file (Test Setup Photo).

Test Report No.: 24010301-01-RF-US-01

**Appendix – Information on the Testing Laboratories**

We, [Hwa-Hsing \(Dongguan\) Testing Co., Ltd.](#), A global provider of TESTING and CERTIFICATION services for consumer products, electronic products and wireless information technology products. Adhering to the core values “HONEST and TRUSTWORTHY, OBJECTIVE and IMPARTIALITY, RIGOROUS and AFFICIENT”, commitment to provide professional, perfect and efficient comprehensive ONE-STOP solution of TESTING and CERTIFICATION services for Manufacturers, Buyers, Traders, Brands, Retailers. Assist client to better manage risk, protect their brands, reduce costs and cut time to over 150 markets in global. Our laboratories are FCC recognized accredited test firms and accredited and approved according to ISO/IEC 17025.

If you have any comments, please feel free to contact us at the following:

Lab Address: [No.101, Building N1, Yuyuan 2 Road, Yuyuan Industrial Park, HuangJiang Town, Dongguan City, People's Republic of China](#)

Contact Tel: [0769-83078199](tel:0769-83078199)

Email: [Customerservice.dg@hwa-hsing.com](mailto:Customerservice.dg@hwa-hsing.com)

Web Site: [www.hwa-hsing.com](http://www.hwa-hsing.com)

The address and road map of all our labs can be found in our web site also.

--- END ---