



PHOENIX  
**TESTLAB**

Königswinkel 10  
32825 Blomberg, Germany  
Phone: +49 (0) 52 35 / 95 00-0  
Fax: +49 (0) 52 35 / 95 00-10  
office@phoenix-testlab.de  
www.phoenix-testlab.de

# Test Report

Report Number:

**F171626E1**

Equipment under Test (EUT):

**Barryvox S**

Applicant:

**Mammut Sports Group AG**

Manufacturer:

**CCS Adaxys AG**



Deutsche  
Akkreditierungsstelle  
D-PL-17186-01-01  
D-PL-17186-01-02  
D-PL-17186-01-03

## References

- [1] **ANSI C63.10-2013**, American National Standard of Procedures for Compliance Testing of Unlicensed Wireless Devices
- [2] **FCC CFR 47 Part 15**, Radio Frequency Devices
- [3] **RSS-210 Issue 9 (August 2016)**, Licence-Exempt Radio Apparatus: Category I Equipment
- [4] **RSS-Gen Issue 4 (November 2014)**, General Requirements for Compliance of Radio Apparatus

## Test Result

The requirements of the tests performed as shown in the overview (clause 4) were fulfilled by the equipment under test.

The complete test results are presented in the following.

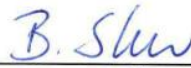
Test engineer:	Thomas KÜHN Name	 Signature	11/03/2017 Date
Authorized reviewer:	Bernd STEINER Name	 Signature	11/03/2017 Date

**This test report is only valid in its original form.**

Any reproduction of its contents in extracts without written permission of the accredited test laboratory PHOENIX TESTLAB GmbH is prohibited.

The test results herein refer only to the tested sample. PHOENIX TESTLAB GmbH is not responsible for any generalisations or conclusions drawn from these test results concerning further samples. Any modification of the tested samples is prohibited and leads to the invalidity of this test report. Each page necessarily contains the PHOENIX TESTLAB Logo and the TEST REPORT NUMBER.

This test report is valid in hardcopy form as well as in electronic form.

## Contents

## Page

1	Identification.....	4
1.1	Applicant.....	4
1.2	Manufacturer.....	4
1.3	Test laboratory.....	4
1.4	EUT (Equipment Under Test).....	5
1.5	Technical data of equipment.....	5
1.6	Dates.....	5
2	Operational states.....	6
3	Additional information.....	6
4	Overview.....	6
5	Results.....	7
5.1	Bandwidth.....	7
5.1.1	Method of measurement (bandwidth).....	7
5.1.2	Test result.....	8
5.2	Maximum unwanted emissions.....	10
5.2.1	Method of measurement (radiated emissions).....	10
5.2.2	Test results (radiated emissions) 150 kHz – 10 GHz.....	17
5.2.2.1	Preliminary radiated emission measurement 150 kHz – 10 GHz.....	17
5.2.2.2	Final radiated measurements.....	21
5.2.2.3	Final radiated emission measurement (150 kHz to 30 MHz).....	21
5.2.2.4	Final radiated emission measurement (30 MHz to 1 GHz).....	21
5.2.2.5	Final radiated emission measurement (1 GHz to 10 GHz).....	23
6	Test equipment and ancillaries used for tests.....	24
7	Report history.....	25
8	List of annexes.....	25

# 1 Identification

## 1.1 Applicant

Name:	Mammut Sports Group AG
Address:	Birren 5 5703 Seon
Country:	Switzerland
Name for contact purposes:	Mr. Ilari DAMMERT
Phone:	Tel. +41 62 769 83 16
eMail Address:	ilari.dammert@mammut.ch
Applicant represented during the test by the following person:	None

## 1.2 Manufacturer

Name:	CCS Adaxys AG
Address:	Alpenblickstraße 26 8853 Lachen
Country:	Switzerland
Name for contact purposes:	Mr. Kurt MÜLLER
Phone:	+41 55 451 78 78
eMail Address:	Kurt.Mueller@ccsedms.com
Manufacturer represented during the test by the following person:	None

## 1.3 Test laboratory

The tests were carried out by: **PHOENIX TESTLAB GmbH**  
**Königswinkel 10**  
**32825 Blomberg**  
**Germany**

accredited by Deutsche Akkreditierungsstelle GmbH (DAkkS) in compliance with DIN EN ISO/IEC 17025 under Reg. No. D-PL-17186-01-02, FCC Test Firm Accreditation with the registration number 469623, designation number DE0004 and Industry Canada Test site registration SITE# IC3469A-1.

## 1.4 EUT (Equipment Under Test)

Test object: *	Avalanche rescue beacon
Type / PMN: *	Barryvox S
FCC ID: *	ARN-BARRYVOX-S
IC: *	8038A-BARRYVOXS
Serial number: *	1729800395
PCB identifier: *	BNG_Barryvox Rev.G01
HVIN (Hardware Version Identification Number): *	7600.0033
FVIN (Firmware Version Identification Number): *	2.0

## 1.5 Technical data of equipment

Antenna type: *	Integrated wire antenna (UHF transceiver) and three integrated ferrite coil antennas (457 kHz transceiver)				
Antenna connector: *	None				
Power supply – EUT: *	$U_{nom} =$	4.5 V DC	$U_{min} =$	4.0 V DC	$U_{max} =$ 6.0 V DC
Type of modulation: *	FHSS / GFSK (UHF transceiver), AM with carrier keying (457 kHz transceiver)				
Data rate: *	50 kbps (UHF transceiver) and no data (457 kHz transceiver)				
Operating frequency range:*	915.9131 to 925.9894 MHz (UHF transceiver) and 457 kHz				
Number of channels: *	50 (UHF transceiver) and 1 (457 kHz transceiver)				
Temperature range: *	-20 °C to 45 °C				
Lowest / highest Internal clock frequency: *	11.882 MHz / 27.0 MHz				
Ancillaries used for testing:	None				

\* Declared by the applicant

The following external I/O cables were used:

Identification	Connector		Length
	EUT	Ancillary	
-	-	-	-
-	No lines are connectable to the EUT		-
-	-	-	-

\*: Length during the test if no other specified.

## 1.6 Dates

Date of receipt of test sample:	10/09/2017
Start of test:	10/12/2017
End of test:	10/30/2017

## 2 Operational states

The EUT is an avalanche rescue beacon. All tests were carried out with an unmodified sample.

During all RF-tests the EUT was supplied with 4.5 V DC by three new AAA batteries.

Because the EUT is a handheld device, the preliminary radiated measurements were carried out with the EUT mounted on a 3-D positioner; the final measurements on the open area test site were carried out in three orthogonal directions. These were defined as follows:

- Pos. 1: EUT lying on the table, display shows upwards.
- Pos. 2: EUT standing on the bottom side, display shows to the measuring antenna.
- Pos. 3: EUT lying on the long side display shows to the measuring antenna.

With the help of a test-software (Monitor Rev. 2385, supplied by the applicant) installed on a laptop PC and a UHF modem (WLink Adapter 462001-70000 C, supplied by the applicant) it was possible to adjust a test mode, where the UHF operating mode could be adjusted. After adjusting the test mode, the connection to the UHF modem was terminated.

The following test modes were adjusted:

Operation mode	Description of the operation mode	Channel
1	Transmits continuously with modulation on 915.9131 MHz	Lowest
2	Transmits continuously with modulation on 920.8485 MHz	Middle
3	Transmits continuously with modulation on 925.9894 MHz	Highest

The 457 kHz transceiver was always operational as transmitter during all tests.

## 3 Additional information

The EUT contains also a 457 kHz transceiver, which is will be certified under another FCC 47 CFR Part 15 section. The measurement results for this rule section are documented under PHOENIX TESTLAB GmbH test report reference F17626E2.

## 4 Overview

Application	Frequency range [MHz]	FCC 47 CFR Part 15 section [2]	RSS-210 [3] or RSS-Gen, Issue 4 [4]	Status	Refer page
Bandwidth	915 MHz to 928 MHz	15.215 (c)	6.6 [4]	Passed	7 et seq.
Radiated emissions (transmitter)	0.150 MHz to 10,000 MHz	15.249 (a), 15.249 (d), 15.205 (a), 15.209 (a).	B.10 [3], 8.9 [4]	Passed	10 et seq.
Antenna requirement	-	15.203	8.3 [4]	Passed *	-

\*: The EUT has an internal antenna only and no antenna connector, so this requirement is regarded as fulfilled.

## 5 Results

### 5.1 Bandwidth

#### 5.1.1 Method of measurement (bandwidth)

The calibration of the spectrum analyser has to be checked with the help of a known signal from a signal generator. The EUT has to be connected to the spectrum analyser via a low loss cable. If the EUT is not equipped with an antenna connector, a temporary antenna connector has to be installed or a test fixture shall be used. The EUT has to be switched on, the transmitter shall work with its maximum data rate.

##### 20 dB bandwidth:

The following spectrum analyser settings shall be used:

- Span: App. 2 to 5 times the OBW, centred on the actual channel.
- Resolution bandwidth: 1 to 5 % of the OBW.
- Video bandwidth: App. three times the RBW.
- Sweep: Auto.
- Detector function: Peak.
- Trace mode: Max hold.

After trace stabilisation the marker shall be set on the signal peak. The first display line has to be set on this value. The second display line has to be set 20 dB below the first line (or the peak marker). The frequency lines shall be set on the intersection points between the second display line and the measured curve.

##### 99 % bandwidth:

The following spectrum analyser settings shall be used:

- Span: wide enough to capture all emission scirts.
- Resolution bandwidth: 1 to 5 % of the OBW.
- Video bandwidth: App. three times the RBW.
- Sweep: Auto.
- Detector function: Peak.
- Trace mode: Max hold.

After trace stabilisation the marker shall be set on the signal peak. Use the 99 % bandwidth functionality of the spectrum analyser to integrate the requested bandwidth.

### 5.1.2 Test result

Ambient temperature	22 °C
---------------------	-------

Relative humidity	42 %
-------------------	------

The plots show an exemplary measurement result for the worst documented case. The other results are listed in the following table.

171626 f2.PNG: 20 dB Bandwidth (operation mode 2):

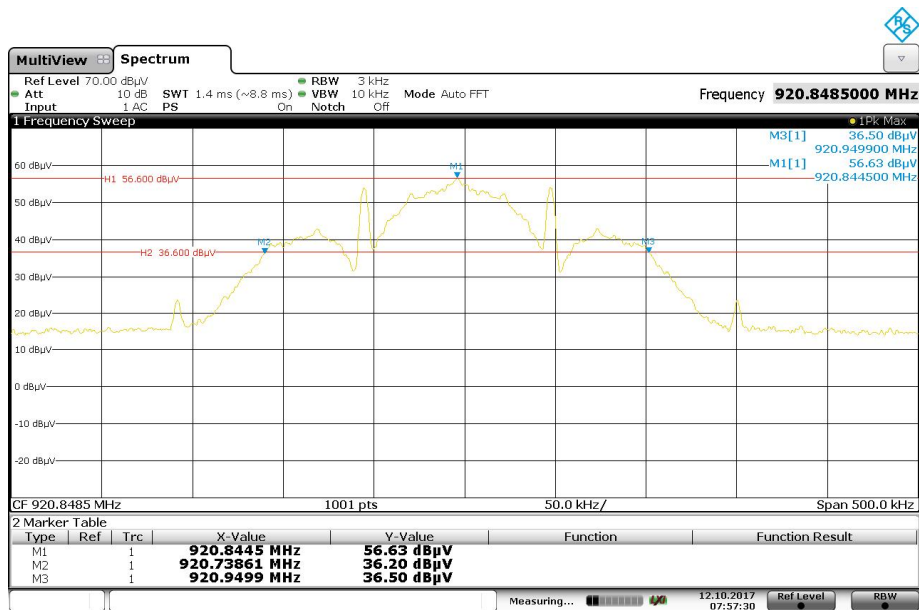

Operation Mode	Center Frequency	$F_L$	$F_U$	20 dB Bandwidth	Result
1	915.9131 MHz	915.803210 MHz	916.015000 MHz	211.790 kHz	Passed
2	920.8485 MHz	920.738610 MHz	920.949900 MHz	211.290 kHz	Passed
3	925.9894 MHz	925.879510 MHz	926.091800 MHz	212.290 kHz	Passed



171626\_f5.PNG: 99% Bandwidth (operation mode 2):

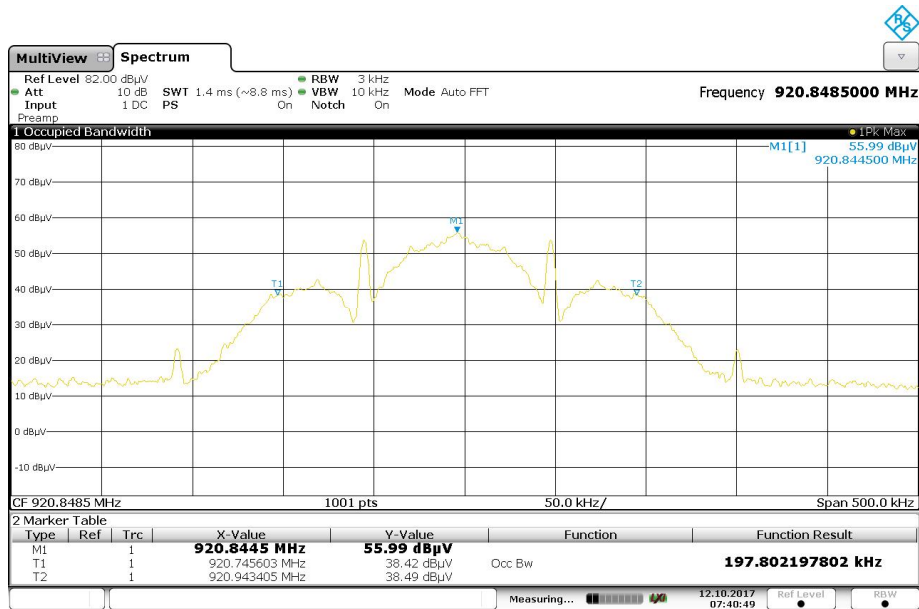

Operation Mode	Center Frequency	$F_L$	$F_U$	99 % Bandwidth	Result
1	915.9131 MHz	915.810203 MHz	916.005005 MHz	197.802 kHz	Passed
2	920.8485 MHz	920.745603 MHz	920.943405 MHz	197.802 kHz	Passed
3	925.9894 MHz	925.886503 MHz	926.084305 MHz	197.802 kHz	Passed

Test equipment used (refer clause 6):

3 – 7, 9, 13, 18

## 5.2 Maximum unwanted emissions

### 5.2.1 Method of measurement (radiated emissions)

The radiated emission measurement is subdivided into five stages.

- A preliminary measurement carried out in a fully anechoic chamber with a fixed antenna height in the frequency range 9 kHz to 1 GHz.
- A final measurement carried out on an outdoor test side without reflecting ground plane and a fixed antenna height in the frequency range 9 kHz to 30 MHz.
- A final measurement carried out on an open area test side with reflecting ground plane and various antenna height in the frequency range 30 MHz to 1 GHz.
- A preliminary measurement carried out in a fully anechoic chamber with a variable antenna distance and height in the frequency range above 1 GHz.
- A final measurement carried out in a fully anechoic chamber with a fixed antenna height in the frequency range above 1 GHz.

#### **Preliminary measurement (9 kHz to 30 MHz):**

In the first stage a preliminary measurement will be performed in a shielded room with a measuring distance of 3 meters. Table top devices will set up on a non-conducting turn device on the height of 1.5m. Floor-standing devices will be placed directly on the turntable/ground plane. The set-up of the Equipment under test will be in accordance to [1].

The frequency range 9 kHz to 30 MHz will be monitored with a spectrum analyser while the system and its cables will be manipulated to find out the configuration with the maximum emission levels if applicable. The EMI Receiver will be set to MAX Hold mode. The EUT and the measuring antenna will be rotated around their vertical axis to found the maximum emissions.

The resolution bandwidth of the spectrum analyser will be set to the following values:

Frequency range	Resolution bandwidth
9 kHz to 150 kHz	200 Hz
150 kHz to 30 MHz	10 kHz

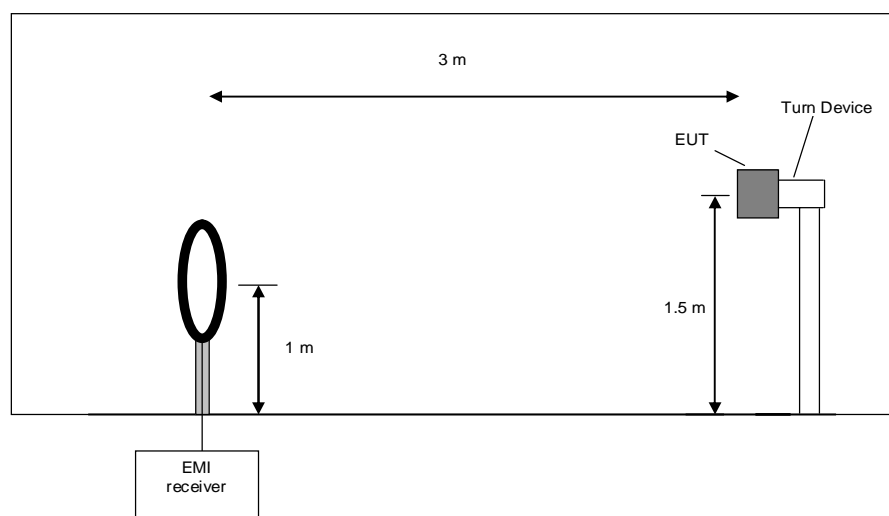

Preliminary measurement procedure:

Prescans were performed in the frequency range 9 kHz to 150 kHz and 150 kHz to 30 MHz.

Prescans were performed in the frequency range 30 MHz to 230 MHz and 230 MHz to 1 GHz.

The following procedure will be used:

1. Monitor the frequency range at horizontal polarisation and a EUT azimuth of 0 °.
2. Manipulate the system cables within the range to produce the maximum level of emission.
3. Rotate the EUT by 360 ° to maximize the detected signals.
4. Repeat 1) to 3) with the vertical polarisation of the measuring antenna.
5. Make a hardcopy of the spectrum.
6. Repeat 1) to 5) with the EUT raised by an angle of 0° (45°, 90°) according to 6.6.5.4 in [1].
7. Measure the frequency of the detected emissions with a lower span and resolution bandwidth to increase the accuracy and note the frequency value.

**Final measurement (9 kHz to 30 MHz):**

In the second stage a final measurement will be performed on an open area test site with no conducting ground plane in a measuring distances of 3 m, 10 m and 30 m. In the case where larger measuring distances are required the results will be extrapolated based on the values measured on the closer distances according to Section 15.31 (f) (2) [2]. The final measurement will be performed with a EMI Receiver set to Quasi Peak detector except for the frequency bands 9 kHz to 90 kHz and 110 kHz to 490 kHz where an average detector will be used according Section 15.209 (d) [2].

On the frequencies, which were detected during the preliminary measurements, the final measurement will be performed while rotating the EUT and the measuring antenna in the range of 0 ° to 360 ° around their vertical axis until the maximum value is found.

The resolution bandwidth of the EMI Receiver will be set to the following values:

Frequency range	Resolution bandwidth
9 kHz to 150 kHz	200 Hz
150 kHz to 30 MHz	9 kHz

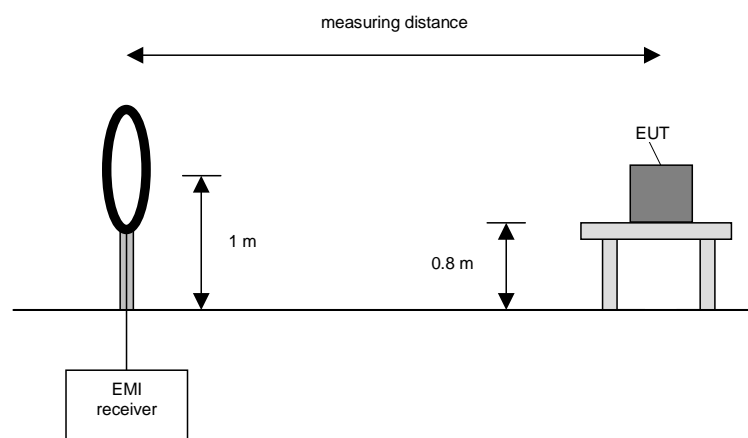

Final measurement procedure:

The following procedure will be used:

1. Monitor the frequency range with the measuring antenna at vertical orientation parallel to the EUT at an azimuth of 0 °.
2. Rotate the EUT by 360 ° to maximize the detected signals and note the azimuth and orientation.
3. Rotate the measuring antenna to find the maximum and note the value.
4. Rotate the measuring antenna and repeat steps 1) to 3) until the maximum value is found.
5. Repeat steps 1) to 4) with the other orthogonal axes of the EUT (if the EUT is a module and might be used in a handheld equipment application).

**Preliminary measurement (30 MHz to 1 GHz)**

In the first stage a preliminary measurement will be performed in a fully anechoic chamber with a measuring distance of 3 meter. Table top devices will set up on a non-conducting turn device on the height of 1.5m. Floor-standing devices will be placed directly on the turntable/ground plane. The set up of the Equipment under test will be in accordance to [1].

The frequency range 30 MHz to 1 GHz will be measured with an EMI Receiver set to MAX Hold mode and a resolution bandwidth of 100 kHz. The measurement will be performed in horizontal and vertical polarisation of the measuring antenna and while rotating the EUT in its vertical axis in the range of 0 ° to 360 °. This measurement is repeated after raising the EUT in 30° steps according 6.6.5.4 in [1].

The resolution bandwidth of the EMI Receiver will be set to the following values:

Frequency range	Resolution bandwidth
30 MHz to 230 MHz	100 kHz
230 MHz to 1 GHz	100 kHz

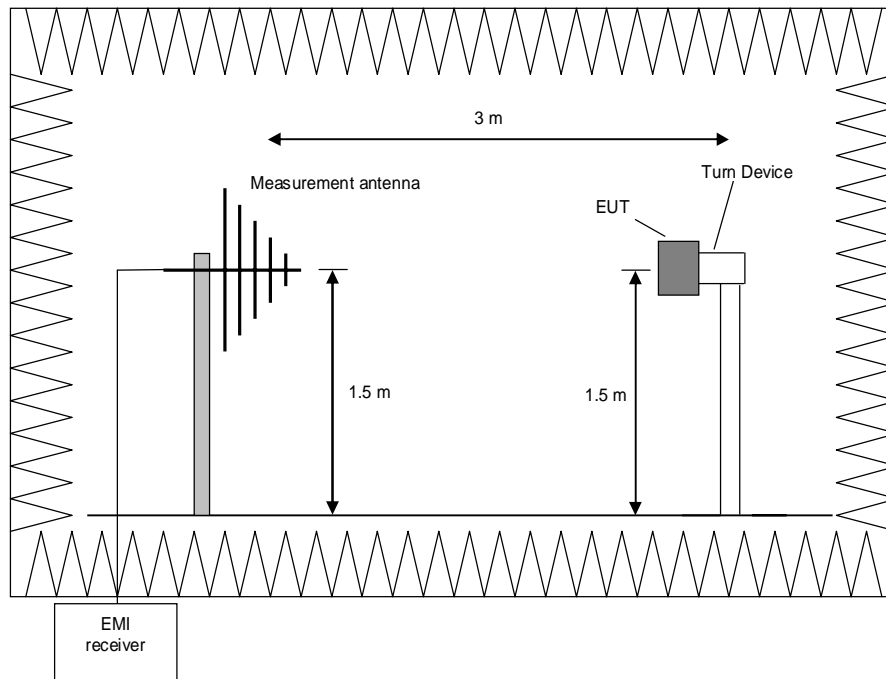

Procedure preliminary measurement:

Prescans were performed in the frequency range 30 MHz to 230 MHz and 230 MHz to 1 GHz.

The following procedure will be used:

1. Monitor the frequency range at horizontal polarisation and a EUT azimuth of 0°.
2. Manipulate the system cables within the range to produce the maximum level of emission.
3. Rotate the EUT by 360° to maximize the detected signals.
4. Repeat 1) to 3) with the vertical polarisation of the measuring antenna.
5. Make a hardcopy of the spectrum.
6. Repeat 1) to 5) with the EUT raised by an angle of 0° (45°, 90°) according to 6.6.5.4 in [1].
7. Measure the frequency of the detected emissions with a lower span and resolution bandwidth to increase the accuracy and note the frequency value.

**Final measurement (30 MHz to 1 GHz)**

A final measurement on an open area test site will be performed on selected frequencies found in the preliminary measurement. During this test the EUT will be rotated in the range of 0° to 360°, the measuring antenna will be set to horizontal and vertical polarisation and raised and lowered in the range from 1 m to 4 m to find the maximum level of emissions.

The resolution bandwidth of the EMI Receiver will be set to the following values:

Frequency range	Resolution bandwidth
30 MHz to 1 GHz	120 kHz

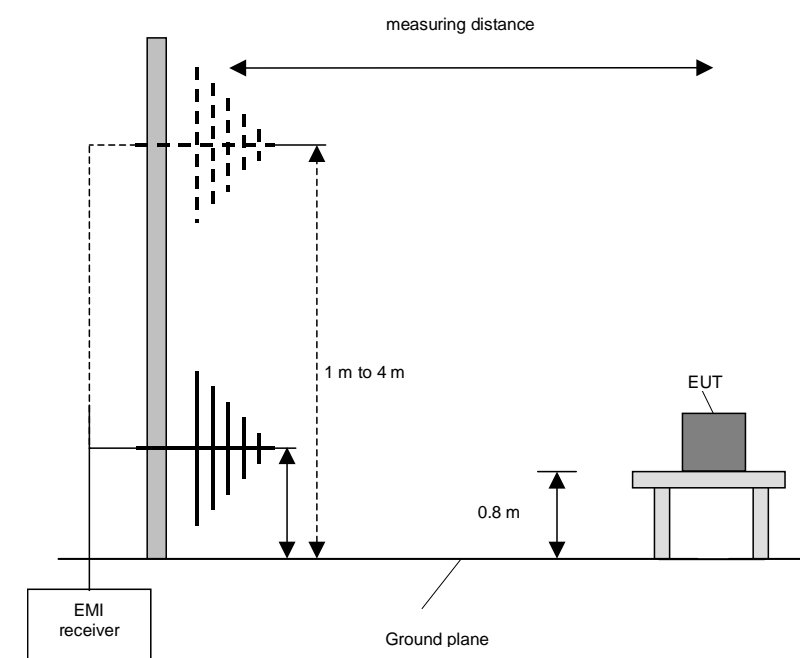

Procedure final measurement:

The following procedure will be used:

1. Measure on the selected frequencies at an antenna height of 1 m and a EUT azimuth of 23 °.
2. Move the antenna from 1 m to 4 m and note the maximum value at each frequency.
3. Rotate the EUT by 45 ° and repeat 2) until an azimuth of 337 ° is reached.
4. Repeat 1) to 3) for the other orthogonal antenna polarization.
5. Move the antenna and the turntable to the position where the maximum value is detected.
6. Measure while moving the antenna slowly +/- 1 m.
7. Set the antenna to the position where the maximum value is found.
8. Measure while moving the turntable +/- 45 °.
9. Set the turntable to the azimuth where the maximum value is found.
10. Measure with Final detector (QP and AV) and note the value.
11. Repeat 5) to 10) for each frequency.
12. Repeat 1) to 11) for each orthogonal axes of the EUT (because of EUT is a module and might be used in a handheld equipment application).

**Preliminary and final measurement (1 GHz to 40 GHz)**

This measurement will be performed in a fully anechoic chamber. Table top devices will set up on a non-conducting turn device on the height of 1.5m. The set-up of the Equipment under test will be in accordance to [1].

**Preliminary measurement (1 GHz to 40 GHz)**

The frequency range will be divided into different sub ranges depending of the frequency range of the used horn antenna. The spectrum analyser set to MAX Hold mode and a resolution bandwidth of 100 kHz. The measurement will be performed in horizontal and vertical polarisation of the measuring antenna and while rotating the EUT in its vertical axis in the range of 0 ° to 360 °. This measurement is repeated after raising the EUT in 30° steps according 6.6.5.4 in [1].

The resolution bandwidth of the EMI Receiver will be set to the following values:

Frequency range	Resolution bandwidth
1 GHz to 4 GHz	100 kHz
4 GHz to 12 GHz	100 kHz
12 GHz to 18 GHz	100 kHz
18 GHz to 25 / 26.5 GHz	100 kHz
26.5 GHz to 40 GHz	100 kHz

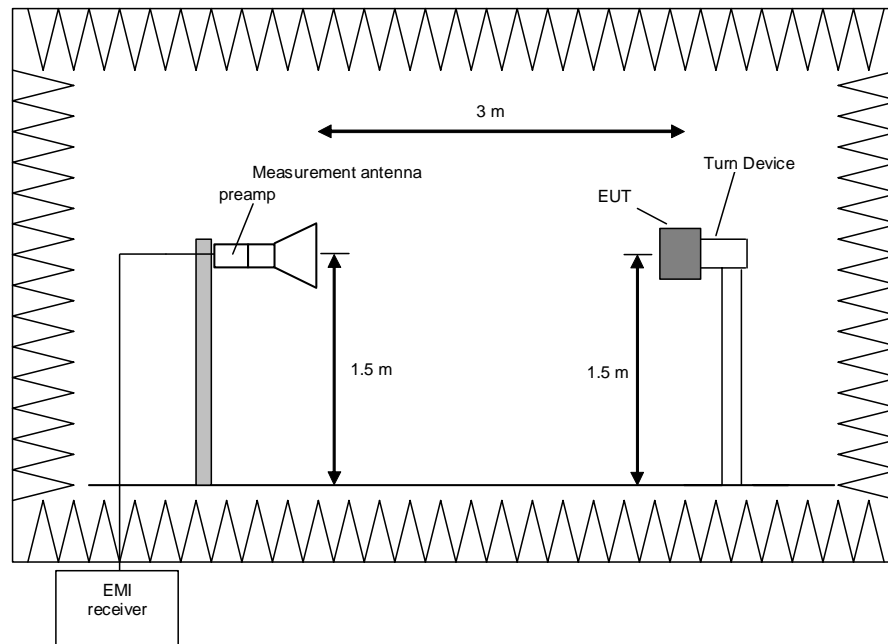

**Procedure preliminary measurement:**

Prescans were performed in the frequency range 1 to 40 GHz.

The following procedure will be used:

1. Monitor the frequency range at horizontal polarisation and a EUT azimuth of 0°.
2. Rotate the EUT by 360° to maximize the detected signals.
3. Repeat 1) to 2) with the vertical polarisation of the measuring antenna.
4. Make a hardcopy of the spectrum.
5. Repeat 1) to 4) with the EUT raised by an angle of 30° (60°, 90°, 120° and 150°) according to 6.6.5.4 in [1].
6. Measure the frequency of the detected emissions with a lower span and resolution bandwidth to increase the accuracy and note the frequency value.
7. The measurement antenna polarisation, with the according EUT position (Turntable and Turn device) which produces the highest emission for each frequency will be used for the final measurement. The six closest values to the applicable limit will be used for the final measurement.

**Final measurement (1 GHz to 40 GHz)**

The frequency range will be divided into different sub ranges depending of the frequency range of the used horn antenna. The EMI Receiver set to peak and average mode and a resolution bandwidth of 1 MHz. The measurement will be performed by rotating the turntable through 0 to 360° in the worst-case EUT orientation which was obtained during the preliminary measurements.

The resolution bandwidth of the EMI Receiver will be set to the following values:

Frequency range	Resolution bandwidth
1 GHz to 4 GHz	1 MHz
4 GHz to 12 GHz	1 MHz
12 GHz to 18 GHz	1 MHz
18 GHz to 25 / 26.5 GHz	1 MHz
26.5 GHz to 40 GHz	1 MHz

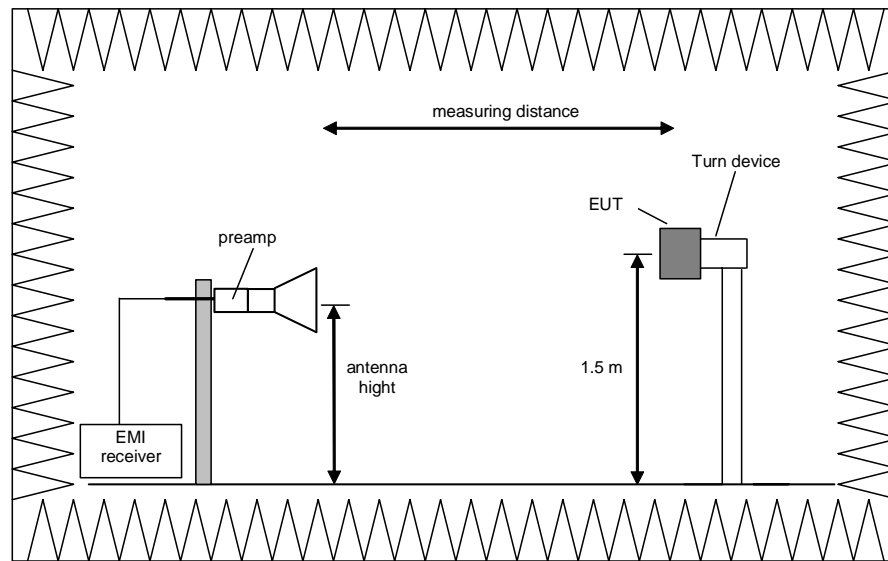

Procedure of measurement:

The measurements were performed in the frequency ranges 1 GHz to 4 GHz, 4 GHz to 12 GHz, 12 GHz to 18 GHz, 18 GHz to 25 /26.5 GHz and 26.5 GHz to 40 GHz.

The following procedure will be used:

1. Set the turntable and the turn device to obtain the worst-case emission for the first frequency identified in the preliminary measurements.
2. Set the measurement antenna polarisation to the orientation with the highest emission for the first frequency identified in the preliminary measurements.
3. Set the spectrum analyser to EMI mode with peak and average detector activated.
4. Rotate the turntable from 0° to 360° to find the TT Pos. that produces the highest emissions.
5. Note the highest displayed peak and average values
6. Repeat the steps 1) to 5) for each frequency detected during the preliminary measurements.



## 5.2.2 Test results (radiated emissions) 150 kHz – 10 GHz

### 5.2.2.1 Preliminary radiated emission measurement 150 kHz – 10 GHz

Ambient temperature	22 °C	Relative humidity	50 %
---------------------	-------	-------------------	------

Position of EUT:	The EUT was set-up on a turn device of a height of 1.5 m. The distance between EUT and antenna was 3 m.
Cable guide:	For detail information of test set-up and the cable guide refer to the pictures in the annex A in the test report.
Test record:	Only the plot of the worst case emission is submitted below.
Supply voltage:	During this test the EUT was powered by fresh batteries with 4.5 V <sub>DC</sub> .
Remark:	Since there were no differences in the spectrum for $f < 30$ MHz, only one representative plot is submitted below.

#### Transmitter operates at the lower end of the assigned frequency band (operation mode 1)

#### Spurious emissions from 30 MHz to 1 GHz (operation mode 1, carrier notched):

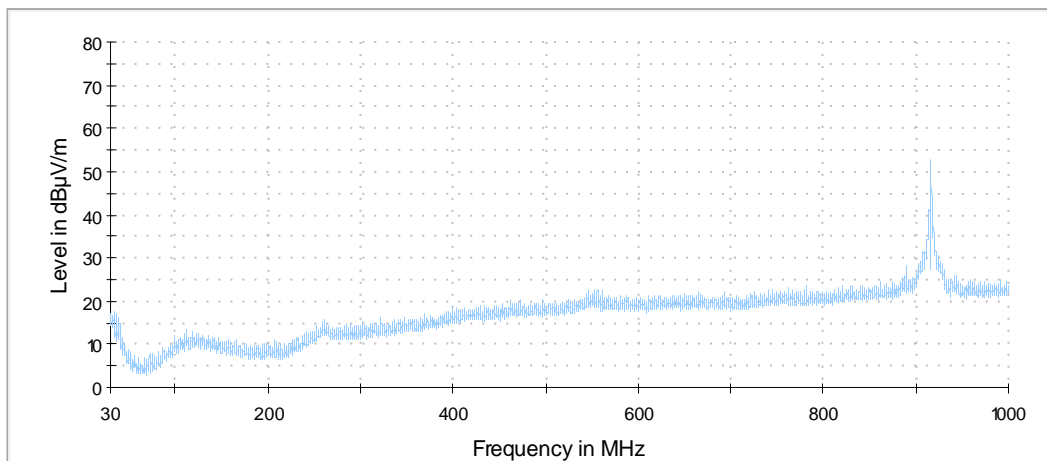

Preview Result 1-PK+

The following frequencies were found outside restricted bands during the preliminary radiated emission test:

- 888.9350 MHz, 913.9125 MHz, 915.9131 MHz, 917.9865 MHz and 942.9155 MHz.

No frequencies were found inside the restricted bands during the preliminary radiated emission test.

These frequencies have to be measured on the open area test site. The results were presented in the following.

Test equipment used (refer clause 6):

2 – 15, 18, 22

Spurious emissions from 1 GHz to 10 GHz (operation mode 1):

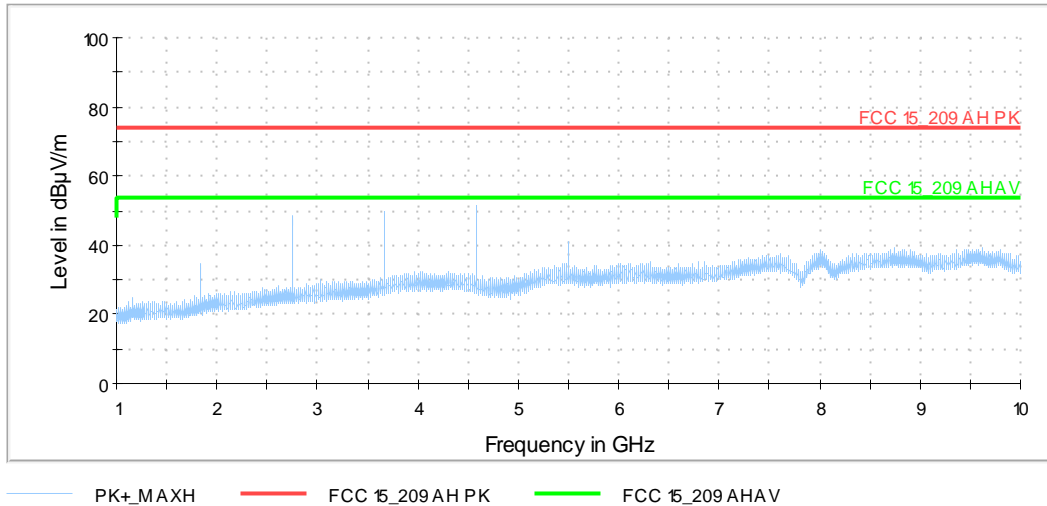

The following frequencies were found outside restricted bands during the preliminary radiated emission test:

- 1831.8262 MHz and 5495.4786 MHz.

The following frequencies were found inside the restricted bands during the preliminary radiated emission test.

- 2747.7393 MHz, 3663.6524 MHz and 4579.5655 MHz.

These frequencies have to be measured in a final measurement. The results were presented in the following.

**Transmitter operates at the middle of the assigned frequency band (operation mode 2)**

Spurious emissions from 150 kHz to 30 MHz (operation mode 2):

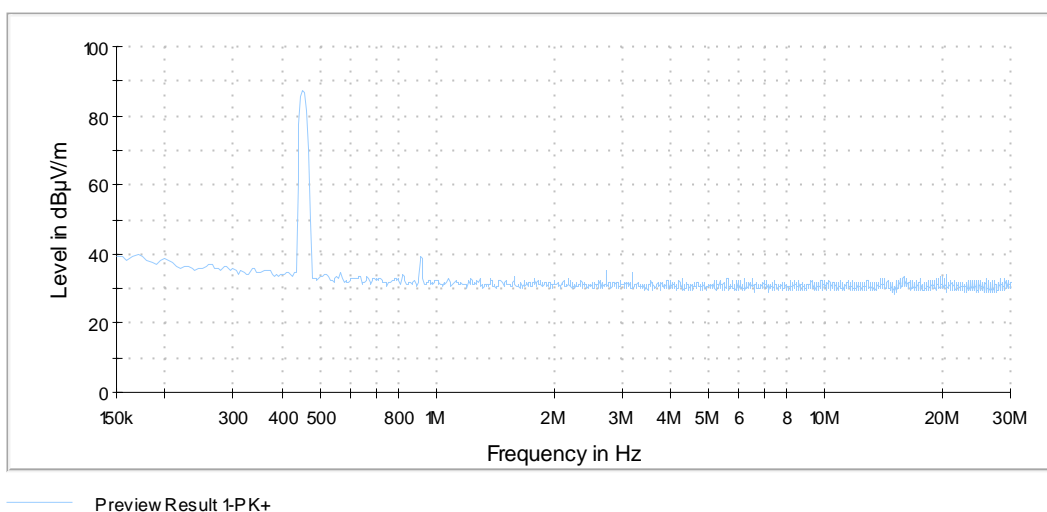

The emissions found in this frequency range are caused by the 457 kHz transceiver of the EUT, which is will be certified under an other FCC 47 CFR Part 15 section. The measurement results for this rule section are documented under PHOENIX TESTLAB GmbH test report reference F17626E2.

Spurious emissions from 30 MHz to 1 GHz (operation mode 2, carrier notched):

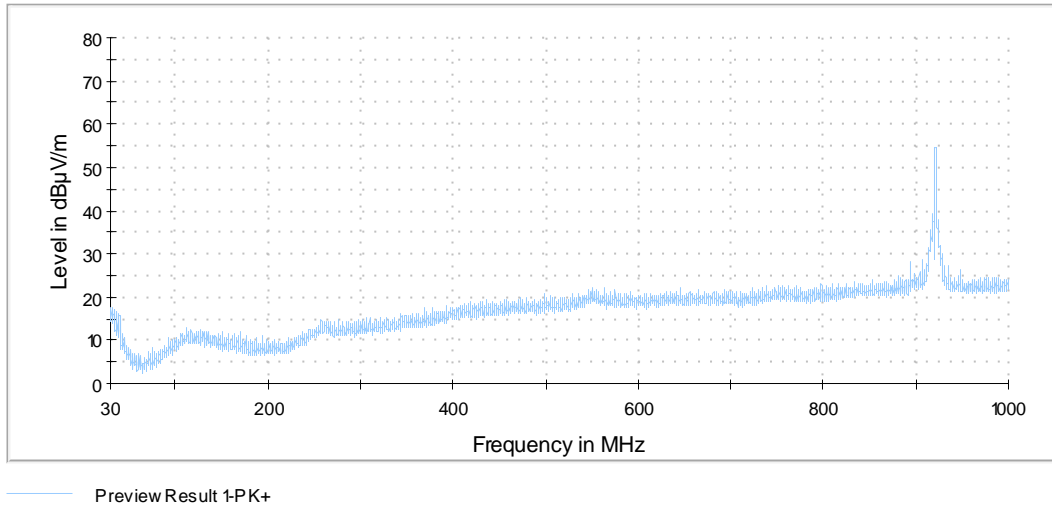

The following frequencies were found outside restricted bands during the preliminary radiated emission test:

- 893.8335 MHz, 907.3165 MHz, 919.0535 MHz, 920.8485 MHz, 922.5940 MHz and 934.3310 MHz.

No frequencies were found inside the restricted bands during the preliminary radiated emission test. These frequencies have to be measured on the open area test site. The results were presented in the following.

Spurious emissions from 1 GHz to 10 GHz (operation mode 2):

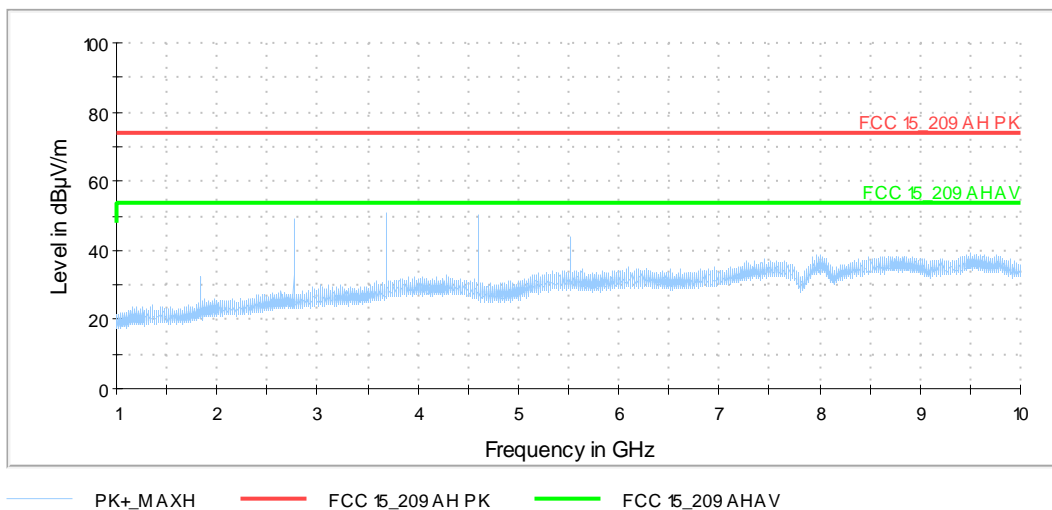

The following frequencies were found outside restricted bands during the preliminary radiated emission test:

- 1841.6970 MHz and 5525.0910 MHz.

The following frequencies were found inside the restricted bands during the preliminary radiated emission test.

- 2762.5455 MHz, 3683.3940 MHz and 4604.2425 MHz.

These frequencies have to be measured in a final measurement. The results were presented in the following.

**Transmitter operates at the upper end of the assigned frequency band (operation mode 3)**

Spurious emissions from 30 MHz to 1 GHz (operation mode 3, carrier notched):

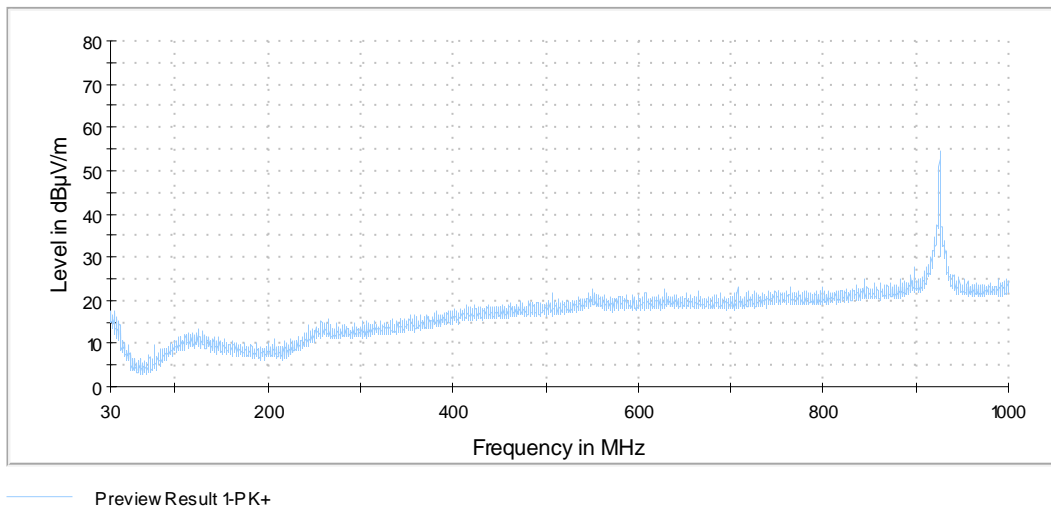

The following frequencies were found outside restricted bands during the preliminary radiated emission test:

- 899.0230 MHz, 919.4415 MHz, 925.9894 MHz and 946.9895 MHz.

No frequencies were found inside the restricted bands during the preliminary radiated emission test.

These frequencies have to be measured on the open area test site. The results were presented in the following.

Spurious emissions from 1 GHz to 10 GHz (operation mode 3):

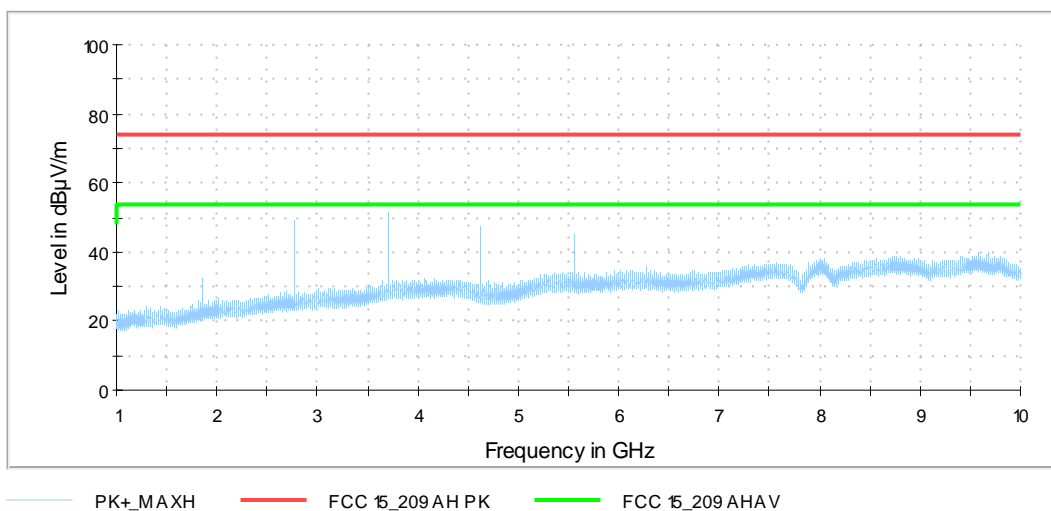

The following frequencies were found outside restricted bands during the preliminary radiated emission test:

- 1851.9788 MHz and 5555.9364 MHz.

The following frequencies were found inside the restricted bands during the preliminary radiated emission test.

- 2777.9682 MHz, 3703.9576 MHz and 4629.9470 MHz.

These frequencies have to be measured in a final measurement. The results were presented in the following.

### 5.2.2.2 Final radiated measurements

### 5.2.2.3 Final radiated emission measurement (150 kHz to 30 MHz)

The emissions found in this frequency range are caused by the 457 kHz transceiver of the EUT, which is will be certified under an other FCC 47 CFR Part 15 section. The measurement results for this rule section are documented under PHOENIX TESTLAB GmbH test report reference F17626E2.

### 5.2.2.4 Final radiated emission measurement (30 MHz to 1 GHz)

Ambient temperature	22 °C	Relative humidity	33 %
---------------------	-------	-------------------	------

Position of EUT: The EUT was set-up on a non-conducting table of a height of 0.8 m in three orthogonal directions. The distance between EUT and antenna was 3 m.

Cable guide: No cables are connectable to the EUT. For detail information of test set-up refer to the pictures in annex A of this test report.

Test record: The maximum results are shown in the following.

Supply voltage: During this test the EUT was powered by fresh batteries with 4.5 V<sub>DC</sub>.

Test results: The test results were calculated with the following formula:

$$\text{Result [dB}\mu\text{V/m]} = \text{reading [dB}\mu\text{V]} + \text{cable loss [dB]} + \text{antenna factor [dB/m]} + 6 \text{ dB}$$

The measured points and the limit line in the following diagrams refer to the standard measurement of the emitted interference in compliance with the above-mentioned standard. The measured points marked with an x are the measured results of the standard final measurement on the open area test site.

The results of the standard subsequent measurement on the open area test site are indicated in the table below. The limits as well as the measured results (levels) refer to the above mentioned standard while taking account of the specified requirements for a 3 m measuring distance.

The measurement time with the quasi-peak measuring detector is 1 second.

Result measured with the quasi-peak detector:

Transmitter operates on the lower end of the assigned frequency band (operation mode 1)											
Frequency (MHz)	QuasiPeak (dB $\mu$ V/m)	Limit (dB $\mu$ V/m)	Margin (dB)	Meas. Time (ms)	Bandwidth (kHz)	Height (cm)	Pol.	Azimuth (deg)	Corr. (dB)	Restr. Band	Pos.
888.9350	33.7	46.0	12.3	1000.0	120.000	100.0	H	241.0	31.0	No	1
913.3120	37.2	46.0	8.8	1000.0	120.000	104.0	H	212.0	31.0	No	1
915.9131	93.8	94.0	0.2	1000.0	120.000	104.0	H	210.0	31.0	No	1
917.9865	40.9	46.0	5.1	1000.0	120.000	104.0	H	210.0	31.1	No	1
942.9155	34.1	46.0	11.9	1000.0	120.000	400.0	V	243.0	31.4	No	1
Transmitter operates on the middle of the assigned frequency band (operation mode 2)											
Frequency (MHz)	QuasiPeak (dB $\mu$ V/m)	Limit (dB $\mu$ V/m)	Margin (dB)	Meas. Time (ms)	Bandwidth (kHz)	Height (cm)	Pol.	Azimuth (deg)	Corr. (dB)	Restr. Band	Pos.
893.8335	33.8	46.0	12.2	1000.0	120.000	104.0	H	242.0	31.0	No	1
907.3165	33.2	46.0	12.8	1000.0	120.000	100.0	H	198.0	31.0	No	1
919.0535	38.9	46.0	7.1	1000.0	120.000	100.0	H	200.0	31.1	No	1
920.8485	93.9	94.0	0.1	1000.0	120.000	100.0	H	198.0	31.1	No	1
922.5940	36.9	46.0	9.1	1000.0	120.000	104.0	H	210.0	31.1	No	1
934.3310	34.7	46.0	11.3	1000.0	120.000	209.0	V	94.0	31.3	No	2
Transmitter operates on the upper end of the assigned frequency band (operation mode 3)											
Frequency (MHz)	QuasiPeak (dB $\mu$ V/m)	Limit (dB $\mu$ V/m)	Margin (dB)	Meas. Time (ms)	Bandwidth (kHz)	Height (cm)	Pol.	Azimuth (deg)	Corr. (dB)	Restr. Band	Pos.
899.0230	32.5	46.0	13.5	1000.0	120.000	104.0	H	213.0	31.0	No	1
919.4415	33.0	46.0	13.0	1000.0	120.000	104.0	H	211.0	31.1	No	1
925.9894	93.0	94.0	1.0	1000.0	120.000	100.0	H	199.0	31.2	No	1
946.9895	34.9	46.0	11.1	1000.0	120.000	400.0	H	316.0	31.4	No	2
Measurement uncertainty						+2.2 dB / -3.6 dB					

Test: Passed

Test equipment used (refer clause 6):

1, 2, 13, 17 - 21
-------------------

### 5.2.2.5 Final radiated emission measurement (1 GHz to 10 GHz)

Ambient temperature	22 °C
---------------------	-------

Relative humidity	42 %
-------------------	------

Transmitter operates on the lower end of the assigned frequency band (operation mode 1)								
Frequency [MHz]	MaxPeak [dB $\mu$ V/m]	Average [dB $\mu$ V/m]	Limit [dB $\mu$ V/m]	Margin (dB)	Pol	Azimuth (deg)	Elevation (deg)	Corr. (dB)
1831.8262	39.1	-	74.0	34.9	V	182.0	120.0	-12.6
	-	34.0	54.0	20.0	V	182.0	120.0	-12.6
2747.7393	50.3	-	74.0	23.7	V	359.0	60.0	-10.4
	-	48.0	54.0	6.0	V	359.0	60.0	-10.4
3663.6524	52.7	-	74.0	21.3	H	152.0	120.0	-6.7
	-	49.7	54.0	4.3	H	152.0	120.0	-6.7
4579.5655	54.0	-	74.0	20.1	H	164.0	120.0	-5.0
	-	51.3	54.0	2.7	H	164.0	120.0	-5.0
5495.4786	46.0	-	74.0	28.0	V	86.0	30.0	-1.7
	-	37.9	54.0	16.1	V	86.0	30.0	-1.7
Transmitter operates on the middle of the assigned frequency band (operation mode 2)								
Frequency [MHz]	MaxPeak [dB $\mu$ V/m]	Average [dB $\mu$ V/m]	Limit [dB $\mu$ V/m]	Margin (dB)	Pol	Azimuth (deg)	Elevation (deg)	Corr. (dB)
1841.6970	38.1	-	74.0	35.9	H	338.0	150.0	-12.5
	-	31.3	54.0	22.7	H	338.0	150.0	-12.5
2762.5455	50.9	-	74.0	23.1	V	359.0	60.0	-10.4
	-	49.0	54.0	5.0	V	0.0	60.0	-10.4
3683.3940	52.5	-	74.0	21.5	H	185.0	120.0	-6.6
	-	49.3	54.0	4.7	H	185.0	120.0	-6.6
4604.2425	52.5	-	74.0	21.5	H	173.0	120.0	-4.9
	-	48.5	54.0	5.5	H	173.0	120.0	-4.9
5525.0910	48.4	-	74.0	25.6	H	113.0	90.0	-1.6
	-	41.5	54.0	12.5	H	113.0	90.0	-1.6
Transmitter operates on the upper end of the assigned frequency band (operation mode 3)								
Frequency [MHz]	MaxPeak [dB $\mu$ V/m]	Average [dB $\mu$ V/m]	Limit [dB $\mu$ V/m]	Margin (dB)	Pol	Azimuth (deg)	Elevation (deg)	Corr. (dB)
1851.9788	37.7	-	74.0	36.3	V	185.0	120.0	-12.4
	-	31.9	54.0	22.1	V	185.0	120.0	-12.4
2777.9682	50.6	-	74.0	23.4	V	350.0	60.0	-10.3
	-	48.6	54.0	5.4	V	350.0	60.0	-10.3
3703.9576	53.5	-	74.0	20.5	H	162.0	120.0	-6.5
	-	50.4	54.0	3.6	H	162.0	120.0	-6.5
4629.9470	50.5	-	74.0	23.5	V	127.0	120.0	-4.9
	-	46.1	54.0	7.9	V	127.0	120.0	-4.9
5555.9364	49.6	-	74.0	24.4	H	101.0	90.0	-1.6
	-	43.0	54.0	11.0	H	101.0	90.0	-1.6
Measurement uncertainty				+2.2 dB / -3.6 dB				

Test: Passed

Test equipment used (refer clause 6):

3 – 8, 10 11, 15 – 17, 18
---------------------------

## 6 Test equipment and ancillaries used for tests

No.	Test equipment	Type	Manufacturer	Serial No.	PM. No.	Cal. Date	Cal. Due
1	EMI Receiver / Spectrum Analyser	ESIB 26	Rohde & Schwarz	100292	481182	02/15/2016	02/2018
2	Software	EMC32	Rohde & Schwarz	100061	481022	Calibration not necessary	
3	Fully anechoic chamber M20	-	Albatross Projects	B83107-E2439-T232	480303	Weekly verification (system cal.)	
4	Signal & Spectrum Analyzer	ESW44	Rohde & Schwarz	101635	482467	06/22/2017	06/2019
5	Controller	MCU	Maturo	MCU/043/971107	480832	Calibration not necessary	
6	Turntable	DS420HE	Deisel	420/620/80	480315	Calibration not necessary	
7	Antenna support	AS615P	Deisel	615/310	480187	Calibration not necessary	
8	Horn antenna	3115	Emco	9609-4918	480183	11/10/2014	11/2017
9	HF-Cable	Sucoflex 104	Huber+Suhner	517406	482391	Weekly verification (system cal.)	
10	RF-cable No. 3	Sucoflex 106B	Huber&Suhner	0563/6B / Kabel 3	480670	Weekly verification (system cal.)	
11	RF-cable No. 40	Sucoflex 106B	Huber&Suhner	0708/6B / Kabel 40	481330	Weekly verification (system cal.)	
12	Loop antenna	HFH2-Z2	Rohde & Schwarz	832609/014	480059	02/29/2016	02/2018
13	Antenna (Bilog)	CBL6112B	Schaffner EMV GmbH (-Chase)	2688	480328	06/19/2017	06/2020
14	Kabel 36	Sucoflex 106B	Suhner	500003/6B / Kabel 36	481680	Weekly verification (system cal.)	
15	Preamplifier	JS3-00101200-23-5A	Miteq	681851	480337	02/18/2016	02/2018
16	1 GHz High Pass Filter	WHJS1000C 11/60EF	Wainwright	1	480413	Annual verification (system cal.)	
17	Attenuator 6 dB	WA2-6	Weinschel	8254	410119	Annual verification (system cal.)	
18	Positioner	TDF 1.5-10Kg	Maturo	15920215	482034	Calibration not necessary	
19	Controller	HD100	Deisel	100/670	480139	Calibration not necessary	
20	Turntable	DS420HE	Deisel	420/620/80	480087	Calibration not necessary	
21	Antenna support	AS615P	Deisel	615/310	480086	Calibration not necessary	
22	Tuneable notch filter	WRCA800/96 0-0.2/40-6EEK	Wainwright	15	480414	Annual verification (system cal.)	



