

Attachment to FCC Form 731

FCC ID: AQZ-VSR-4201-001

Exhibit 12

RX Operational Description

Paragraph 2.1033(b)4

General Information

The Harris Model VSR-4201-001 is designed to be a differential Global Positioning System (GPS) VHF ground station receiver for use in Special Category I (SCAT-1) landing and approach systems. The VSR-4201-001 VHF Receiver and the Harris Model VSR-4141-001 VHF Transmitter together form a radio data broadcast subsystem. The receiver functionally supports the continual integrity assessment of the differential correction data being transmitted, and the RF signal characteristics of the transmitter. The receiver is used to receive and demodulate the signals from the transmitter and report the messages received to a ground facility differential correction processor. The receiver uses time mark pulses to test the timing of the received messages. An external interface diagram of the VHF Receiver is shown in Figure 1.

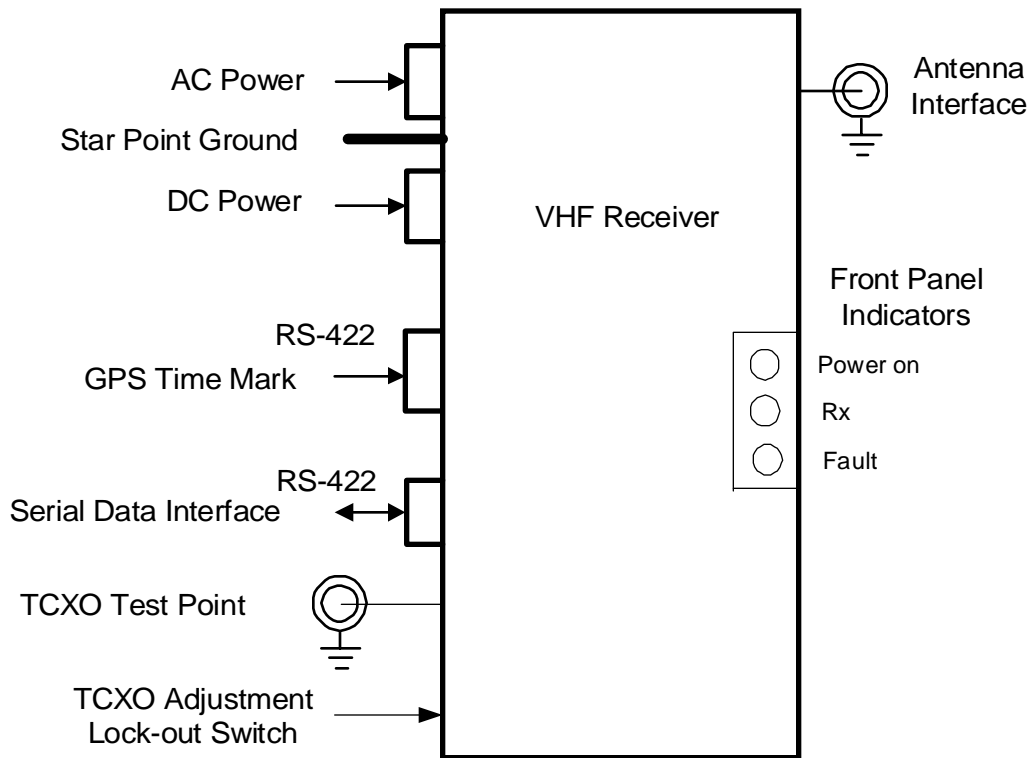

Figure 1. Interface Block Diagram, VHF Receiver