

Emissions Test Report

EUT Name: Asset Tracker

Model No.: AT-1U-H1

CFR 47 Part 15.247:2016 and RSS-247:2017

Prepared for:

Deepak Kumar
Enlighted , Inc.
930 Benecia Avenue
Sunnyvale, CA 94085 USA

Prepared by:

TUV Rheinland of North America, Inc.
1279 Quarry Lane, Ste. A
Pleasanton, CA 94566 U.S.A.
Tel: (925) 249-9123
Fax: (925) 249-9124
<http://www.tuv.com/>

Report/ Re-issue Date: April 28, 2017
Report Number: 31663554.001
Project Number: 0000144179
Revision Number 0

Revisions

Revision No.	Date MM/DD/YYYY	Reason for Change	Author
0	12/13/2016	Original Document	BMJ
0	04/28/2016	First Revision Model type correction FCC ID correction Added Test Data clarification	BMJ

Note: Latest revision report will replace all previous reports.

Statement of Compliance

Manufacturer: Enlighted , Inc.
930 Benecia Avenue
Sunnyvale, CA 94085 USA

Requester / Applicant: Deepak Kumar

Name of Equipment: Asset Tracker

Model No. AT1UH1

Type of Equipment: Intentional Radiator

Application of Regulations: CFR 47 Part 15.247:2016 and RSS-247:2015

Test Dates: 18 November 2016 to 12 December 2016

Guidance Documents:

Emissions: ANSI C63.10-2013, KDB 558074 D01 DTS Measurement Guidance v03r05

Test Methods:

Emissions: ANSI C63.10-2013, KDB 558074 D01 DTS Measurement Guidance v03r05

The electromagnetic compatibility test and documented data described in this report has been performed and recorded by TUV Rheinland, in accordance with the standards and procedures listed herein. As the responsible authorized agent of the EMC laboratory, I hereby declare that the equipment described above has been shown to be compliant with the EMC requirements of the stated regulations and standards based on these results. If any special accessories and/or modifications were required for compliance, they are listed in the Executive Summary of this report.

This report must not be used to claim product endorsement by A2LA or any agency of the U.S. Government. This report contains data that are not covered by A2LA accreditation. This report shall not be reproduced except in full, without the written authorization of TUV Rheinland of North America.

<u>Bernd Jungbluth</u>	<u>April 28, 2017</u>	<u>David Spencer</u>	<u>April 28, 2017</u>
Test Engineer	Revision Date	Laboratory Signature	Revision Date



**INDUSTRY
CANADA**

Testing Cert #3331.02

US1131

2932M-1

Contents

1 Executive Summary.....7

1.1 Scope.....7

1.2 Purpose.....7

1.3 Summary of Test Results.....8

1.4 Special Accessories.....9

1.5 Equipment Modifications.....9

2 Laboratory Information.....9

2.1 Accreditations & Endorsements.....9

 2.1.1 US Federal Communications Commission.....9

 2.1.2 NIST / A2LA.....9

 2.1.3 Canada – Industry Canada.....9

 2.1.4 Japan – VCCI.....9

 2.1.5 Acceptance by Mutual Recognition Arrangement.....10

2.2 Test Facilities.....10

 2.2.1 Emission Test Facility.....10

 2.2.2 Immunity Test Facility.....10

2.3 Measurement Uncertainty.....11

 2.3.1 Sample Calculation – radiated & conducted emissions.....11

 2.3.2 Measurement Uncertainty Emissions.....11

 2.3.3 Measurement Uncertainty Immunity.....12

2.4 Calibration Traceability.....12

3 Product Information.....13

3.1 Product Description.....13

3.2 Operating Mode.....13

3.3 Unique Antenna Connector.....14

 3.3.1 Results.....14

4 Emission Requirements – 2400 MHz to 2483.5 MHz Band.....15

4.1 Output Power Requirements.....15

 4.1.1 Test Method.....15

 4.1.2 Results.....16

4.2 Occupied Bandwidth.....20

 4.2.1 Test Method.....20

 4.2.2 Results.....21

4.3 Power Spectral Density Requirements.....25

 4.3.1 Test Method.....25

 4.3.2 Results.....25

Table 4: BLE mode.....25

4.4 Out of Band Emission requirements.....29

Table of Contents

4.4.1 Results 30
4.4.2 Band Edge Results 31
4.4.3 Out of Band Emissions 32
4.5 Transmitter Spurious Emissions 38
4.5.1 Test Methodology 38
4.5.2 Transmitter Spurious Emission Limit 39
4.5.3 Test Results 39
4.5.4 Sample Calculation 52
4.6 Maximum Permissible Exposure 53
4.6.1 Test Methodology 53
4.6.2 RF Exposure Limit 53
4.6.3 EUT Operating Condition 53
4.6.4 Classification 54
4.6.5 Test Results 54
4.6.6 Sample Calculation 54
5 Test Equipment Use List 55
5.1 Equipment List 55
6 EMC Test Plan 56
6.1 Introduction 56
6.2 Customer 56
6.3 Equipment Under Test (EUT) 57
6.4 Test Specifications 60

Index of Tables

Table 1: Summary of Test Results	8
Table 2: RF Output Power at the Antenna Port – Test Results	16
Table 3: Occupied Bandwidth – Test Results BLE	21
Table 7: Transmit Spurious Emission at Restricted Band Edge Requirements	40
Table 8: Customer Information	56
Table 9: Technical Contact Information.....	56
Table 10: EUT Specifications	57
Table 11: Interface Specifications	57
Table 12: Supported Equipment.....	58
Table 13: Description of Sample used for Testing.....	58
Table 14: Description of Test Configuration used for Radiated Measurement.....	58
Table 15: Final Test Mode for 2402 MHz to 2480MHz Channels.....	59
Table 16: Test Specifications.....	60

1 Executive Summary

1.1 Scope

This report is intended to document the status of conformance with the requirements of the CFR 47 Part 15.247:2016 and RSS-247:2017 based on the results of testing performed on 18 November 2016 to 12 December 2016 on the Asset Tracker Model AT1UH1 manufactured by Enlighted , Inc. This report only applies to the specific samples tested under the stated test conditions. It is the responsibility of the manufacturer to assure that additional production units of this model are manufactured with identical or EMI equivalent electrical and mechanical components. This report is further intended to document changes and modifications to the EUT throughout its life cycle. All documentation will be included as a supplement.

1.2 Purpose

Testing was performed to evaluate the EMC performance of the EUT in accordance with the applicable requirements, procedures, and criteria defined in the application of regulations and application of standards listed in this report.

The report documents the 2.4GHz BLE radio characteristics for the AT1UH1.

1.3 Summary of Test Results

Table 1: Summary of Test Results

Test	Test Method ANSI C63.4:2014/ ANSI C63.10:2013	Test Parameters	Measured Value	Result
2402 MHz to 2480 MHz Band BLE				
Spurious Emission in Transmitted Mode	CFR47 15.209, CFR47 15.247 (d) RSS-GEN Sect.8.9, RSS 247 Sect. 6.2.1.2	Class B	48.21 dBuV -5.79 dB (Margin)	Complies
Restricted Bands of Operation	CFR47 15.205, RSS GEN Sect.8.10	Class B		Complies
Peak Power Spectral Density	CFR47 15.247 (e), RSS-247 Sect. 5.2 (2)	8 dBm/ 3 kHz	-11.64 dBm	Complies
Occupied Bandwidth	CFR47 15.247 (a1), RSS GEN Sect.6.6	≥ 500 kHz	6dB BW = 825 kHz 99% BW = 1.643 MHz	Complies
Maximum Transmitted Power	CFR47 15.247 (b1), RSS 247 Sect. 5.4.4	30 dBm w/ 6 dBi antenna	2.38 dBm (1.73mW)	Complies
Out of Band Emission	CFR47 15.247 (d), RSS 247 Sect. 5.5	-30 dB	-36.7dBm -7.6 dB (Margin)	Complies
RF Exposure	CFR47 15.247 (i), 2.1091/ RSS- 102 Section 2.5.2	General Population	Within the limits	Complies

1.4 Special Accessories

No special accessories were necessary in order to achieve compliance.

1.5 Equipment Modifications

None

2 Laboratory Information

2.1 Accreditations & Endorsements

2.1.1 US Federal Communications Commission



TUV Rheinland of North America at 1279 Quarry Ln, Pleasanton, CA 94566 is recognized by the commission for performing testing services for the general public on a fee basis. These laboratory test facilities have been fully described in reports submitted to and accepted by the FCC (US1131). The laboratory scope of accreditation includes: Title 47 CFR Parts 15, 18, and 90. The accreditation is updated every 3 years.

2.1.2 NIST / A2LA



TUV Rheinland of North America is accredited by the National Voluntary Laboratory Accreditation Program, which is administered under the auspices of the National Institute of Standards and Technology. The laboratory has been assessed and accredited in accordance with ISO Guide 17025:2005 and ISO 9002 (Lab Code 3331.02). The scope of laboratory accreditation includes emission and immunity testing. The accreditation is updated annually.

2.1.3 Canada – Industry Canada



TUV Rheinland of North America at the 1279 Quarry Ln, Pleasanton, CA 94566 address is accredited by Industry Canada for performing testing services for the general public on a fee basis. This laboratory test facilities have been fully described in reports submitted to and accepted by Industry Canada (File Number 2932M). This reference number is the indication to the Industry Canada Certification Officers that the site meets the requirements of RSS 212, Issue 1 (Provisional). The accreditation is updated every 3 years.

2.1.4 Japan – VCCI



The Voluntary Control Council for Interference by Information Technology Equipment (VCCI) is a group that consists of Information Technology Equipment (ITE) manufacturers and EMC test laboratories. The purpose of the Council is to take voluntary control measures against electromagnetic interference from Information Technology Equipment, and thereby contribute to the development of a socially beneficial and responsible state of affairs in the realm of Information Technology Equipment in Japan. TUV Rheinland of North America at 1279 Quarry Ln, Pleasanton, CA 94566 has been assessed and approved in accordance with the Regulations for Voluntary Control Measures.

VCCI Registration No. for Pleasanton: A-0031

VCCI Registration No. for Santa Clara: A-0032

2.1.5 Acceptance by Mutual Recognition Arrangement



The United States has an established agreement with specific countries under the Asia Pacific Laboratory Accreditation Corporation (APLAC) Mutual Recognition Arrangement. Under this agreement, all TUV Rheinland at 1279 Quarry Ln, Pleasanton, CA 94566 test results and test reports within the scope of the laboratory NIST / A2LA accreditation will be accepted by each member country.

2.2 Test Facilities

All of the test facilities are located at 1279 Quarry Lane, Pleasanton, California 94566, USA. The 2305 Mission College, Santa Clara, 95054, USA location is considered a Pleasanton annex.

2.2.1 Emission Test Facility

The Semi-Anechoic chamber and AC Line Conducted measurement facility used to collect the radiated and conducted data has been constructed in accordance with ANSI C63.7:1992. The site has been measured in accordance with and verified to comply with the theoretical normalized site attenuation requirements of ANSI C63.4-2014, at a test distance of 3 and 5 meters. The site is listed with the FCC and accredited by A2LA (Lab Code 3331.02). The 3/5-meter semi-anechoic chamber used to collect the radiated data has been verified to comply with the theoretical normalized site attenuation requirements of ANSI C63.4-2014, at a test distance of 3 meter and 5 meters. A report detailing this site can be obtained from TUV Rheinland of North America.

2.2.2 Immunity Test Facility

ESD, EFT, Surge, PQF: These tests are performed in an environmentally controlled room with a 3.7 m x 4.8 m x 3.175 mm thick aluminum floor connected to PE ground.

For ESD testing, tabletop equipment is placed on an insulated mat with a surface resistivity of 10^9 Ohms/square on a 1.6 m x 0.8 m x 0.8 m high non-conductive table with a 3.175 mm aluminum top (Horizontal Coupling Plane). The HCP is connected to the main ground plane via a low impedance ground strap through two 470-k Ω resistors. The Vertical Coupling Plane consists of an aluminum plate 50 cm x 50 cm x 3.175 mm thick. The VCP is connected to the main ground plane via a low impedance ground strap through two 470-k Ω resistors.

For EFT, Surge, PQF, the HCP and VCP are removed.

RF Field Immunity testing is performed in a 7.3m x 4.3m x 4.1m anechoic chamber.

RF Conducted and Magnetic Field Immunity testing is performed on a 4.8m x 3.7m x 3.175mm thick aluminum ground plane.

All test areas allow a minimum distance of 1 meter from the EUT to walls or conducting objects.

2.3 Measurement Uncertainty

Two types of measurement uncertainty are expressed in this report, per *ISO Guide To The Expression Of Uncertainty In Measurement*, 1st Edition, 1995.

The Combined Standard Uncertainty is the standard uncertainty of the result of a measurement when that result is obtained from the values of a number of other quantities; it is equal to the positive square root of the sum of the variances or co-variances of these other quantities, weighted according to how the measurement result varies with changes in these quantities. The term *standard uncertainty* is the result of a measurement expressed as a standard deviation.

2.3.1 Sample Calculation – radiated & conducted emissions

The field strength is calculated by subtracting the Amplifier Gain and adding the Cable Loss and Antenna Correction Factor to the measured reading. The basic equation is as follows:

$$\text{Field Strength (dB}\mu\text{V/m)} = \text{RAW} - \text{AMP} + \text{CBL} + \text{ACF}$$

Where: RAW = Measured level before correction (dB μ V)

AMP = Amplifier Gain (dB)

CBL = Cable Loss (dB)

ACF = Antenna Correction Factor (dB/m)

$$\mu\text{V/m} = 10^{\frac{\text{dB}\mu\text{V/m}}{20}}$$

Sample radiated emissions calculation @ 30 MHz

Measurement +Antenna Factor–Amplifier Gain+Cable loss=Radiated Emissions (dB μ V/m)

$$25 \text{ dB}\mu\text{V/m} + 17.5 \text{ dB} - 20 \text{ dB} + 1.0 \text{ dB} = 23.5 \text{ dB}\mu\text{V/m}$$

2.3.2 Measurement Uncertainty Emissions

Per CISPR 16-4-2	U _{lab}	U _{cispr}
Radiated Disturbance @ 10 meters		
30 – 1,000 MHz	2.25 dB	4.51 dB
Radiated Disturbance @ 3 meters		
30 – 1,000 MHz	2.26 dB	4.52 dB
1 – 6 GHz	2.12 dB	4.25 dB
6 – 18 GHz	2.47 dB	4.93 dB
Conducted Disturbance @ Mains Terminals		
150 kHz – 30 MHz	1.09 dB	2.18 dB
Disturbance Power		
30 MHz – 300 MHz	3.92 dB	4.3 dB

Voltech PM6000A

The estimated combined standard uncertainty for harmonic current and flicker measurements is $\pm 5.0\%$.	Per CISPR 16-4-2 Methods
--	--------------------------

2.3.3 Measurement Uncertainty Immunity

The estimated combined standard uncertainty for ESD immunity measurements is $\pm 8.2\%$.	Per IEC 61000-4-2
The estimated combined standard uncertainty for radiated immunity measurements is ± 4.10 dB.	Per IEC 61000-4-3
The estimated combined standard uncertainty for conducted immunity measurements with CDN is ± 3.66 dB	Per IEC 61000-4-6
The estimated combined standard uncertainty for power frequency magnetic field immunity is $\pm 11.6\%$.	Per IEC 61000-4-8

Thermo KeyTek EMC Pro

The estimated combined standard uncertainty for EFT fast transient immunity measurements is $\pm 5.84\%$.
The estimated combined standard uncertainty for surge immunity measurements is $\pm 5.84\%$.
The estimated combined standard uncertainty for voltage variation and interruption measurements is $\pm 3.48\%$.

The expanded uncertainty at a level of 95% confidence is obtained by multiplying the combined standard uncertainty by a coverage factor of 2. Compliance criteria are not based on measurement uncertainty.

Measurement Uncertainty – Radio Testing

The estimated combined standard uncertainty for frequency error measurements is ± 3.88 Hz
The estimated combined standard uncertainty for carrier power measurements is ± 1.59 dB.
The estimated combined standard uncertainty for adjacent channel power measurements is ± 1.47 dB.
The estimated combined standard uncertainty for modulation frequency response measurements is ± 0.46 dB.
The estimated combined standard uncertainty for transmitter conducted emission measurements is ± 4.01 dB

The expanded uncertainty at a level of 95% confidence is obtained by multiplying the combined standard uncertainty by a coverage factor of 2. Compliance criteria are not based on measurement uncertainty.

2.4 Calibration Traceability

All measurement instrumentation is traceable to the National Institute of Standards and Technology (NIST). Measurement method complies with ANSI/NCSL Z540-1-1994 and ISO Standard 17025:2005.

3 Product Information

3.1 Product Description

The Enlighted , Inc. BLE Asset Tracker Model AT1UH1 can be deployed at variable assets to allow tracking within for example an building complex.

A description of the equipment configuration is given in the Test Plan Section. The EUT was tested as called for in the test standard and was configured and operated in a manner consistent with its intended use. The EUT was connected to rated power and allowed to reach intended operating conditions. The placement of the EUT system components was guided by the test standard and selected to represent typical installation conditions.

In the case of a EUT that can operate in more than one configuration, preliminary testing was performed to determine the configuration that produced maximum radiation.

The final configuration was selected to produce the worst case radiation for emissions testing and to place the EUT in the most susceptible state for immunity testing.

3.2 Operating Mode

A description of the operation mode is given in the Test Plan Section. In the case of a EUT that can operate in more than one state, preliminary testing was performed to determine the operating mode that produced maximum radiation.

The final operating mode was selected to produce the worst case radiation for emissions testing and to place the EUT in the most susceptible state for immunity testing.

3.3 Unique Antenna Connector

An intentional radiator shall be designed to ensure that no antenna other than that furnished by the responsible party shall be used with the device. The use of a permanently attached antenna or of an antenna that uses a unique coupling to the intentional radiator shall be considered sufficient to comply with the provisions of this Section. The manufacturer may design the unit so that a broken antenna can be replaced by the user, but the use of a standard antenna jack or electrical connector is prohibited. This requirement does not apply to carrier current devices or to devices operated under the provisions of CFR47 Parts 15.211, 15.213, 15.217, 15.219, or 15.221.

3.3.1 Results

The EUT model AT1UH1 uses the permanently attached PCB trace antennas inside the device. Refer to EUT Photo for details. There is no external antenna connection available.

4 Emission Requirements – 2400 MHz to 2483.5 MHz Band

Testing was performed in accordance with CFR 47 Part 15.247: 2016 and RSS 247: 2015. These test methods are listed under the laboratory's A2LA Scope of Accreditation. This test measures the levels emanating from the EUT, thus evaluating the potential for the EUT to cause radio frequency interference to other electronic devices. Procedures described in Section 8 of the standard were used.

4.1 Output Power Requirements

The maximum output power requirement is the maximum equivalent isotropic radiated power delivering at the transmitting antenna under specified conditions of measurements in the presence of modulation.

The maximum output power and harmonics shall not exceed CFR47 Part 15.247 (b1) and RSS 247 Sect. 5.4.4: 2015

Frequency hopping systems in the 2400-2483.5 MHz band: 1 watts.

4.1.1 Test Method

The conducted method was used to measure the channel power output according to ANSI C63.10:2013 Section 11.9.2.2.2. The measurement was performed with modulation per CFR47 Part 15.247 (b 1):2015 and RSS-247 Sect. 5.4.2. This test was conducted on 3 channels on AT1UH1. The worst mode results are indicated below.

Test Setup:

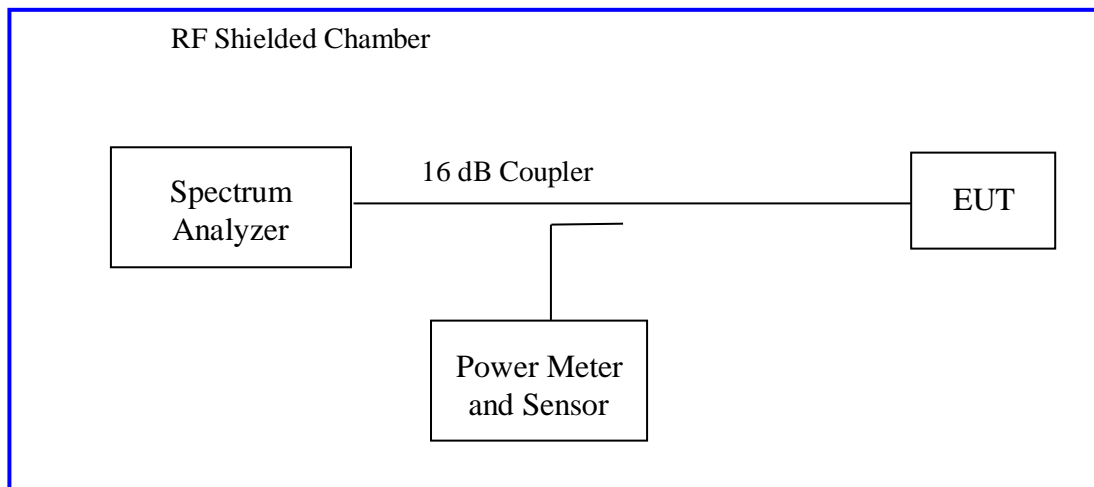

4.1.2 Results

As originally tested, the EUT was found to be compliant to the requirements of the test standard(s).

Table 2: RF Output Power at the Antenna Port – Test Results

Test Conditions: Conducted Measurement		Date: December 08, 2016	
Antenna Type: Integrated		Power Setting: Fixed	
Max. Antenna Gain: 0 dBi		Signal State: Modulated	
Duty Cycle: 98 %		Data Rate: Fixed	
Ambient Temp.: 20° C		Relative Humidity: 36 %RH	
802.15.1 Mode			
Operating Channel	Limit [dBm]	Power [dBm]	Margin [dB]
2402 MHz	+30.00	2.38	-27.62
2440 MHz	+30.00	2.23	-27.77
2480 MHz	+30.00	2.03	-28.97
Note: RF output power executed as peak measurements.			

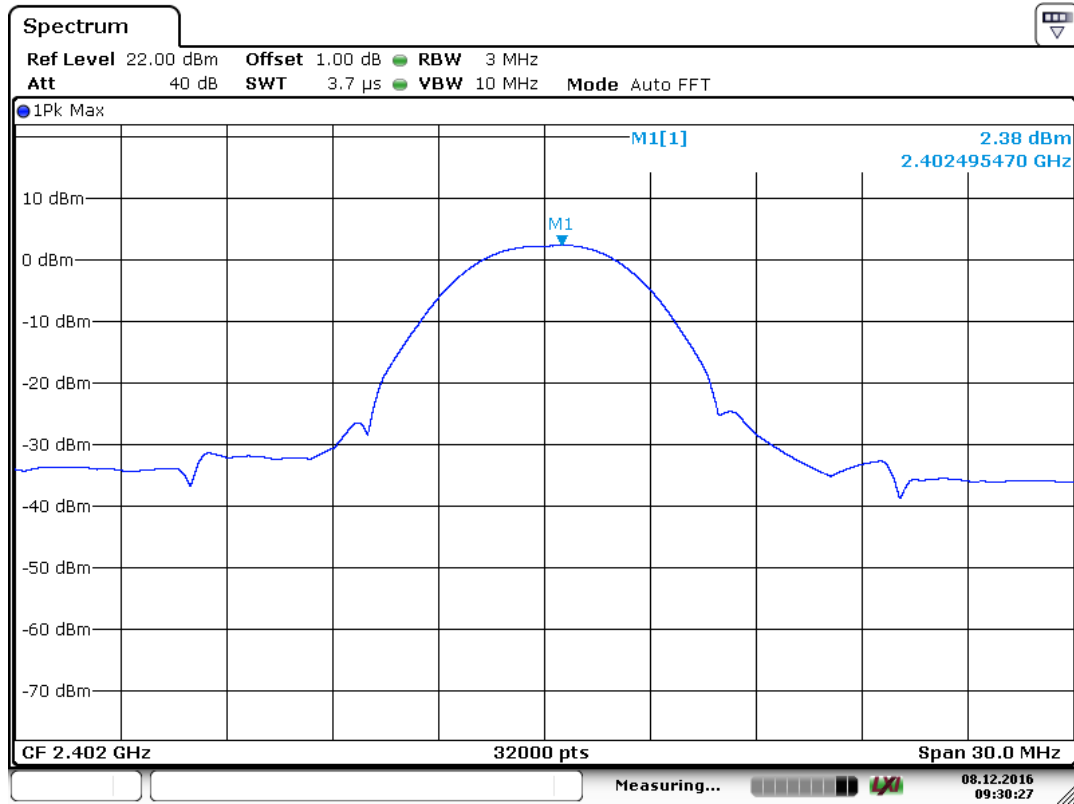
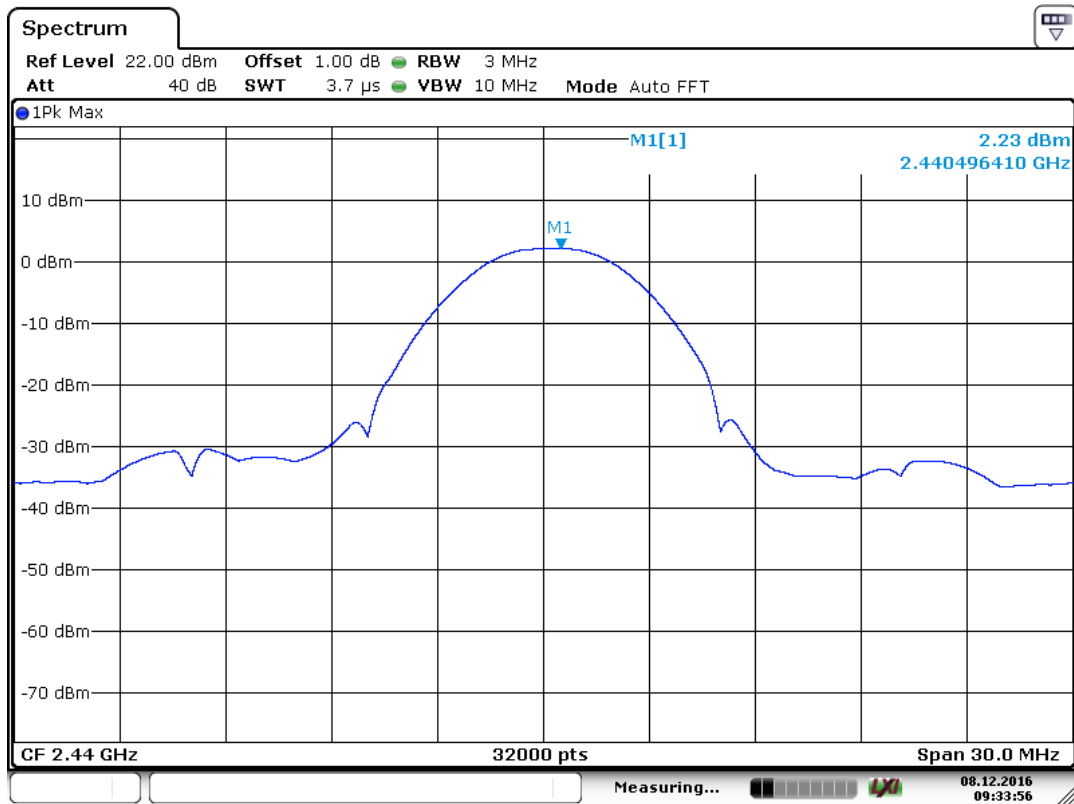
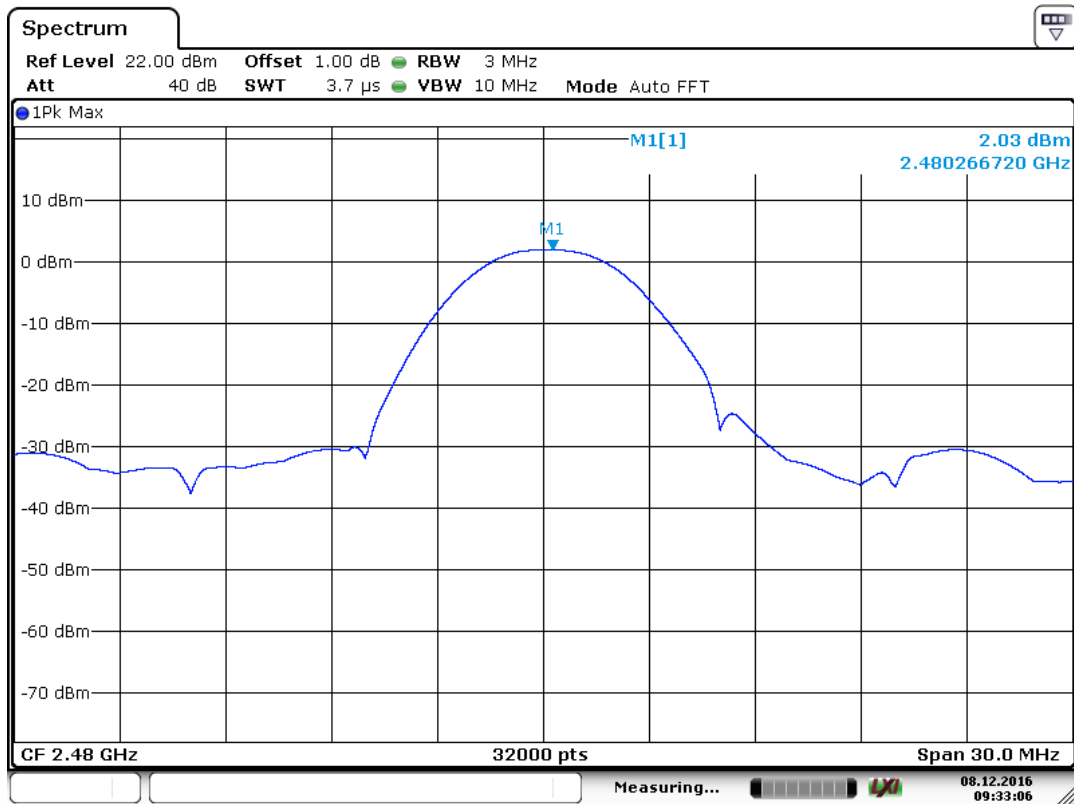

Figure 1: Maximum Transmitted Power, 2402 MHz



Date: 8.DEC.2016 09:33:56

Figure 2: Maximum Transmitted Power, 2440 MHz



Date: 8.DEC.2016 09:33:06

Figure 3: Maximum Transmitted Power, 2480 MHz

4.2 Occupied Bandwidth

The occupied bandwidth is measured at an amplitude level reduced from the reference level by a specified ratio. The reference level is the level of the highest amplitude signal observed from the transmitter at the fundamental frequency.

The 99% bandwidth is the bandwidth in which 99% of the transmitted power occupied.

20 dB bandwidth was performed by coupling the output of the EUT to the input of a spectrum analyzer.

4.2.1 Test Method

The conducted method was used to measure the occupied bandwidth. The measurement was performed with modulation per CFR47 15.247(a) (1) 2015 and RSS 247 Sect. 5.2.1. This test was conducted on 3 channels on the AT1UH1. The worst sample result indicated below.

Test Setup:

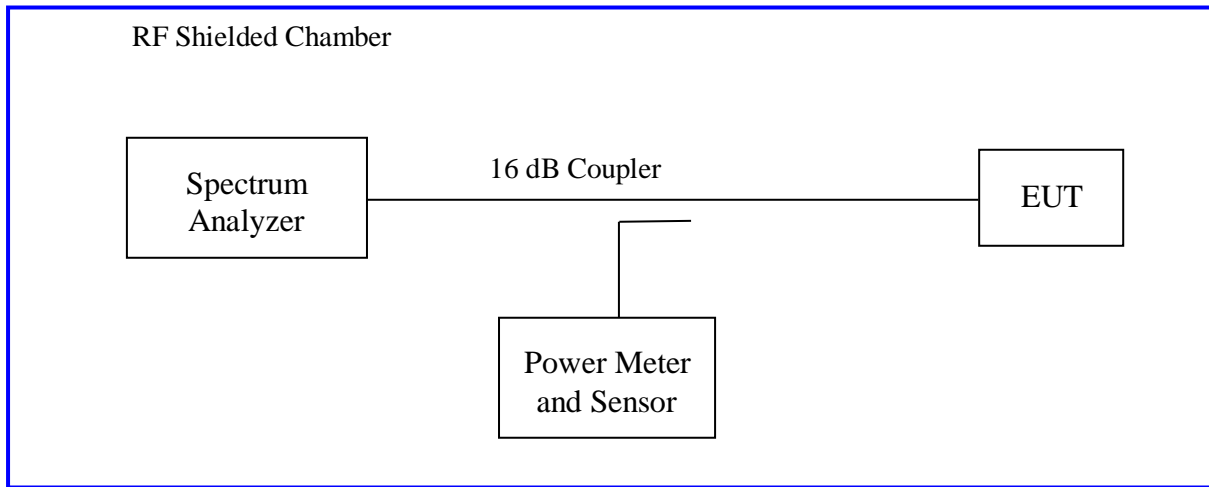

4.2.2 Results

The additional measurements are included for informational purposes only.

Table 3: Occupied Bandwidth – Test Results BLE

Test Conditions: Conducted Measurement		Date: December 08, 2016
Antenna Type: Integrated		Power Setting: Fixed.
Max. Antenna Gain: +0 dBi		Signal State: Modulated
Duty Cycle: 98 %		Data Rate: Fixed
Ambient Temp.: 20° C		Relative Humidity: 36 %RH
Bandwidth (MHz)		
Freq. (MHz)	6dB Bandwidth MHz	99% Bandwidth MHz
2402	0.825	1.643
2440	0.695	1.520
2480	0.695	1.426
Note: Worst case for frequency range is plotted below.		

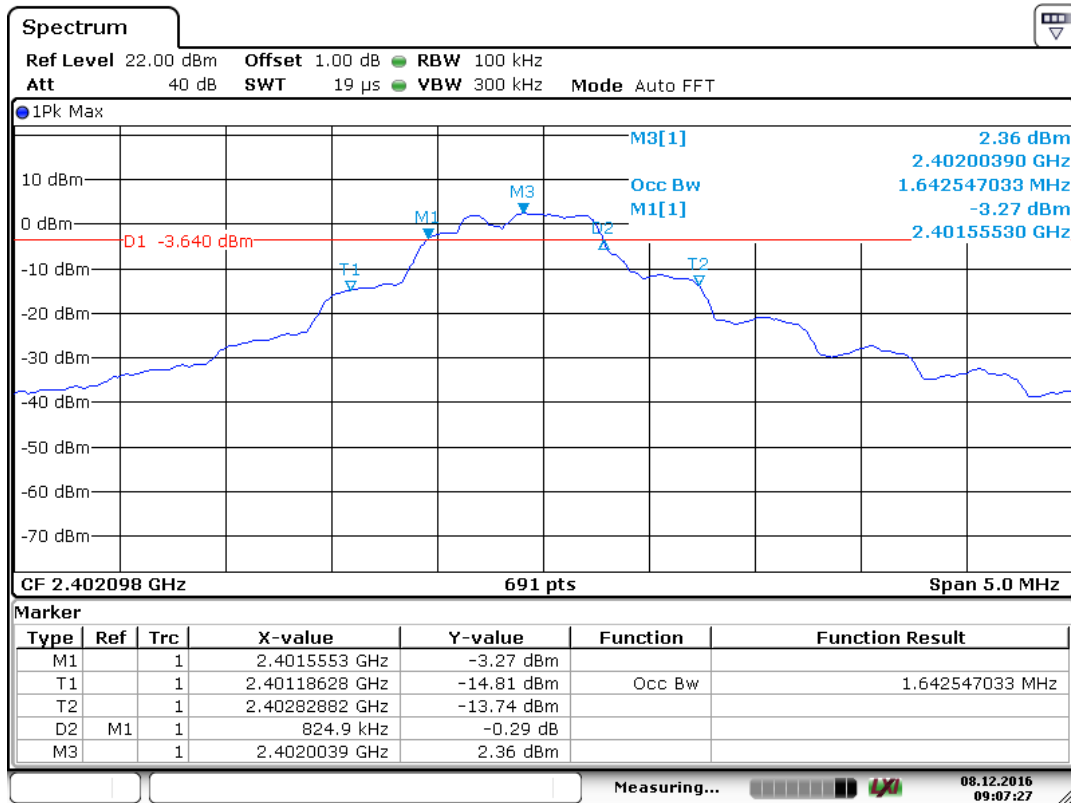

Date: 8.DEC.2016 09:07:27

Figure 4: Occupied Bandwidth at 2402 MHz

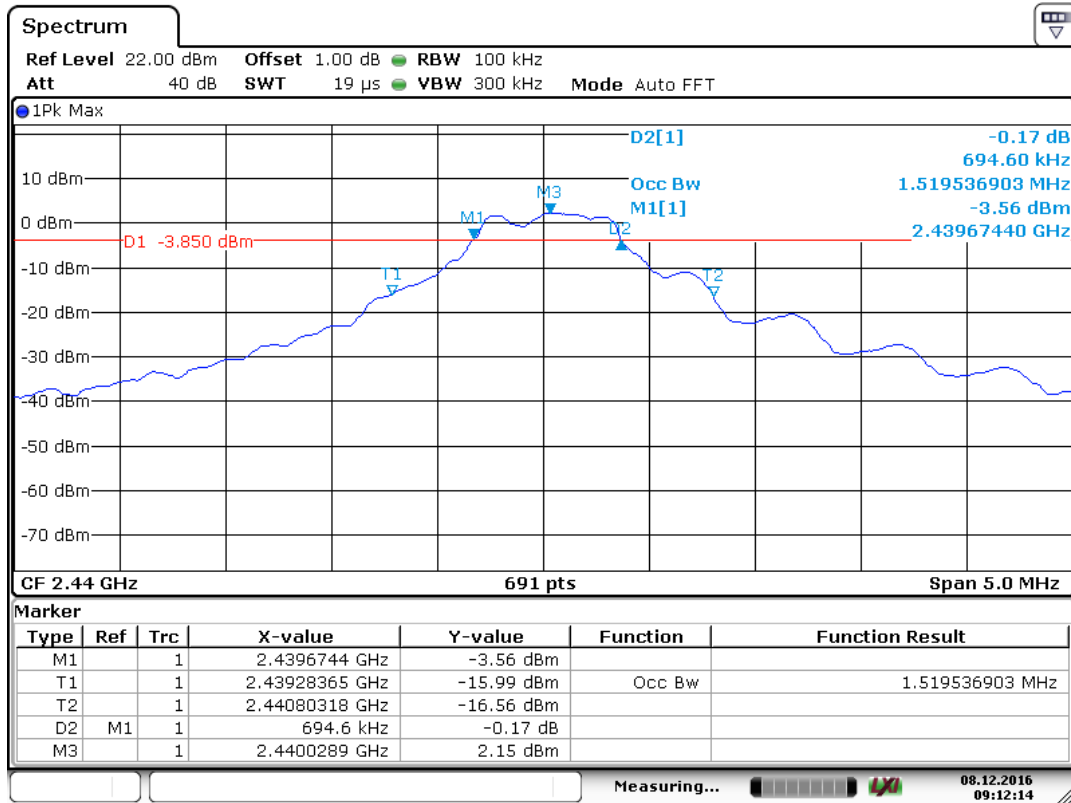

Date: 8.DEC.2016 09:12:14

Figure 5: Occupied Bandwidth at 2440 MHz

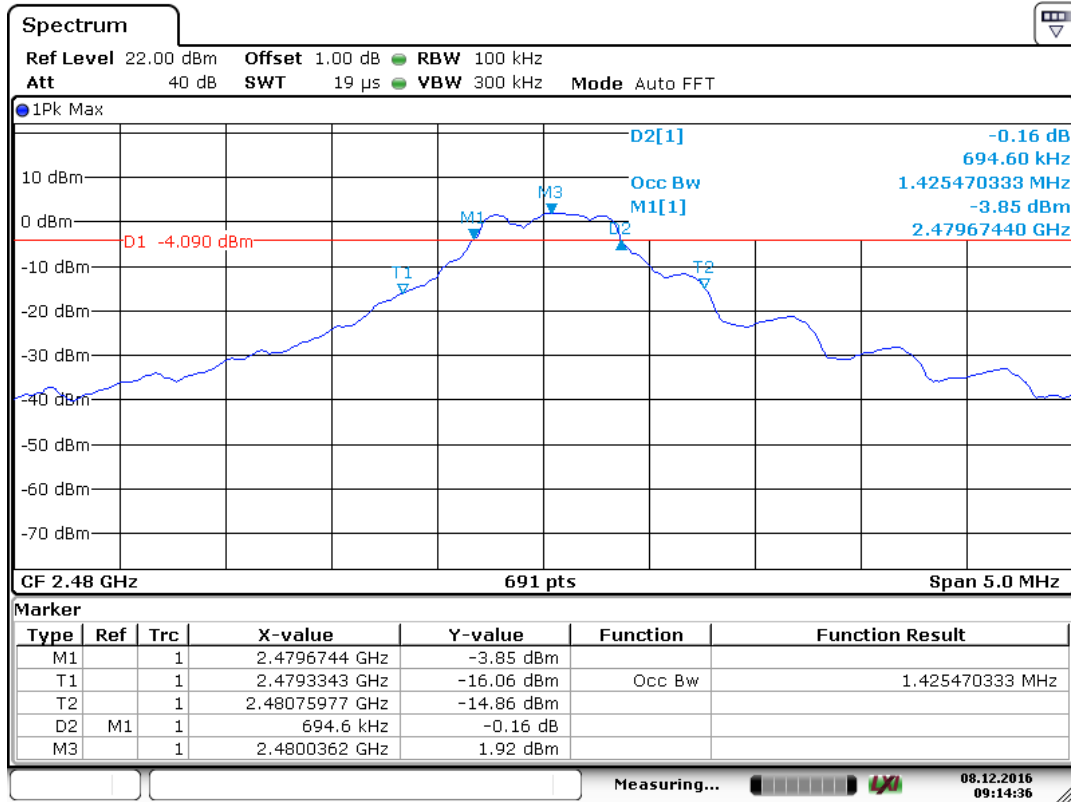

Date: 8.DEC.2016 09:14:37

Figure 6: Occupied Bandwidth at 2480 MHz BLE

4.3 Power Spectral Density Requirements

According to the CFR47 Part 15.247 (e) and RSS-247 (5.2.2), the spectral power density output of the antenna port shall be less than 8dBm in any 3kHz band during any time interval of continuous transmission.

4.3.1 Test Method

The conducted method was used to measure the channel power output per ANSI C63.10:2009 Section 6.11.2. The measurement was performed with modulation per CFR47 Part 15.247 (e) and RSS-247 (5.2.2). This test was conducted on 3 channels. The worst sample result indicated below.

The setup was identical to RF output power measurement.

4.3.2 Results

As originally tested, the EUT was found to be compliant to the requirements of the test standard(s).

Table 4: BLE mode

Test Conditions: Conducted Measurement		Date: December 08, 2016	
Antenna Type: Integrated		Power Setting: Fixed	
Max. Antenna Gain: 0 dBi		Signal State: Modulated	
Duty Cycle: 98 %		Data Rate: Fixed	
Ambient Temp.: 20° C		Relative Humidity: 36 %RH	
802.15.4 Mode			
Operating Channel	Limit [dBm]	PSD [dBm]	Margin [dB]
2402 MHz	+8.00	-12.00	-20.00
2440 MHz	+8.00	-11.64	-19.64
2480 MHz	+8.00	-11.70	-19.70
Note:			

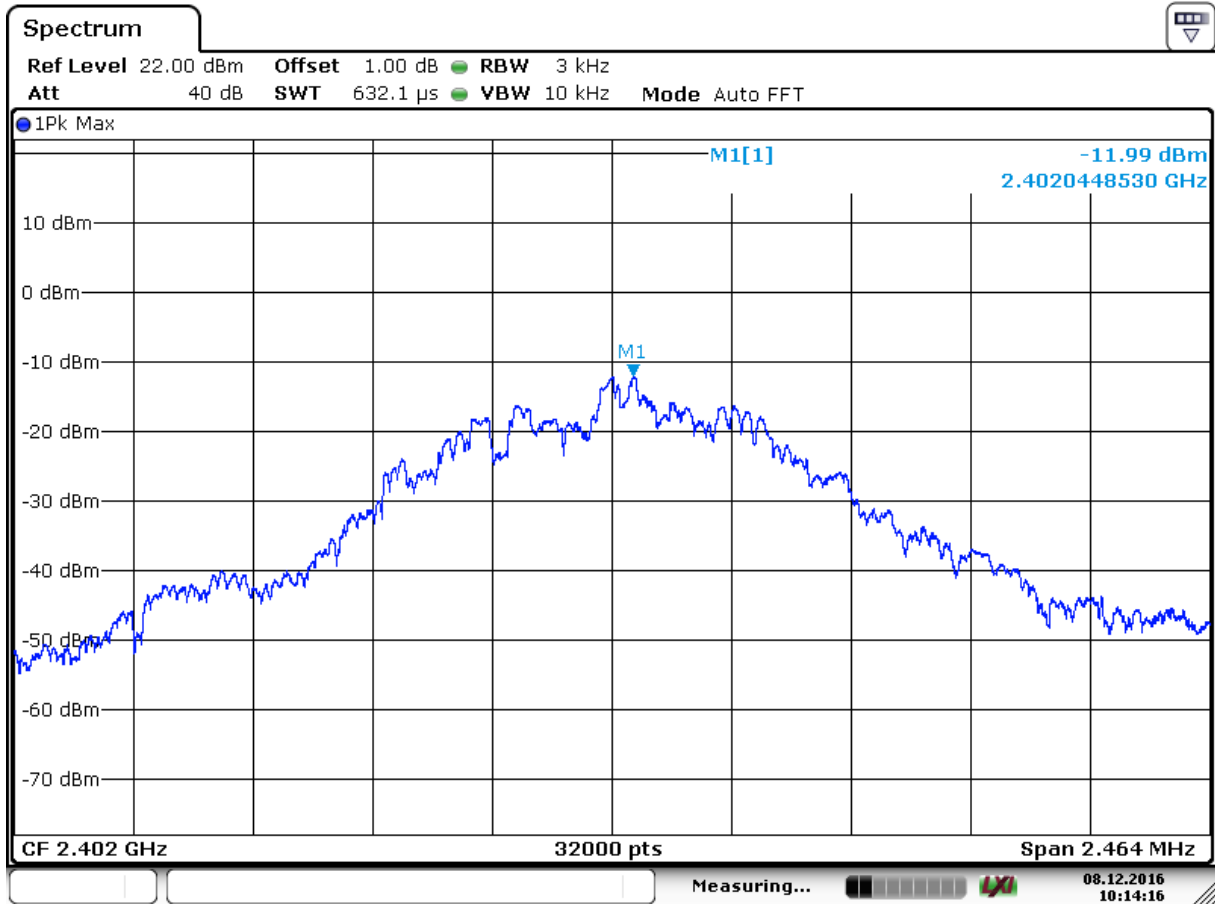

Date: 8 DEC 2016 10:14:16

Figure 7: Power Spectral Density 2402 BLE mode

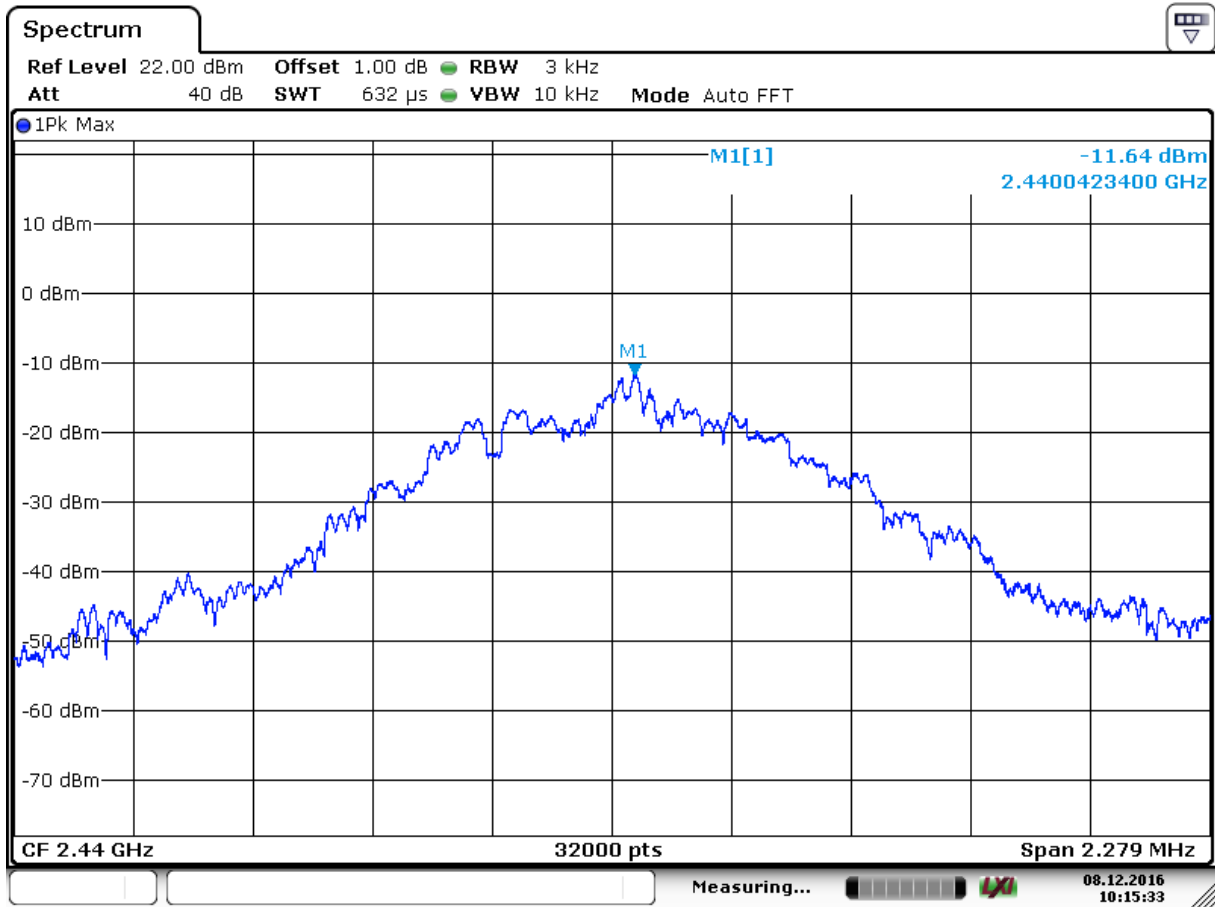

Date: 8 DEC 2016 10:15:33

Figure 8: Power Spectral Density 2440 BLE mode

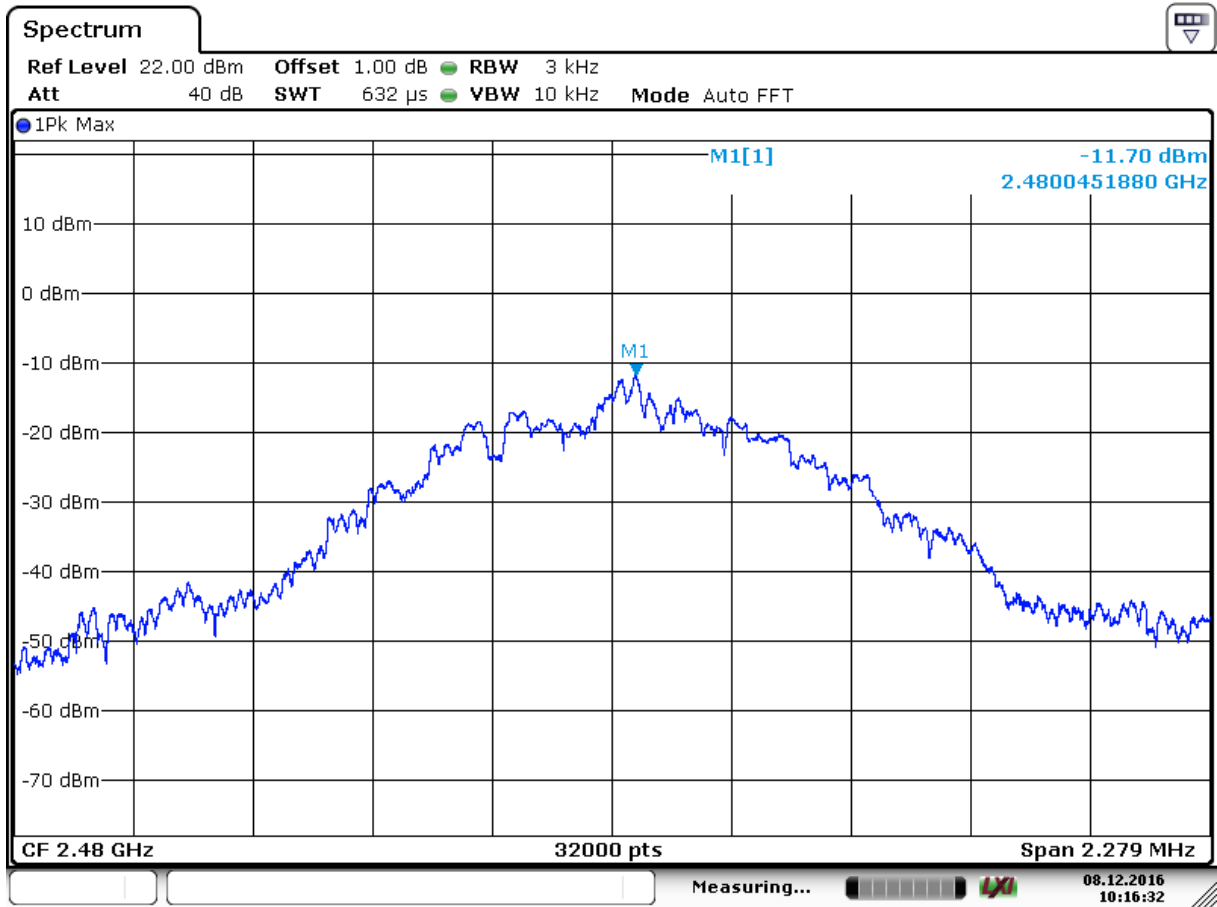

Date: 8.DEC.2016 10:16:32

Figure 9: Power Spectral Density 2480 BLE mode

4.4 Out of Band Emission requirements

The setup was identical to RF output power measurement. Intentional radiators operating under the alternative provisions to the general emission limits, must be designed to ensure that the 20 dB bandwidth of the emission, or whatever bandwidth may otherwise be specified in the specific rule section under which the equipment operates, is contained within the frequency band designated in the rule section under which the equipment is operated. The requirement to contain the designated bandwidth of the emission within the specified frequency band includes the effects from frequency sweeping, frequency hopping and other modulation techniques that may be employed as well as the frequency stability of the transmitter over expected variations in temperature and supply voltage. If the frequency stability is not specified in the regulations, it is recommended that the fundamental emission be kept within at least the central 80% of the permitted band in order to minimize the possibility of out-of-band operation.

Since the transmitter complies with the conducted power limits base on the use of RMS averaging per CFR47 Part 15.247(b)(3), any frequency outside the band of 2400MHz to 2483.5 MHz, the power output level must be below 30 dB from the in-band transmitting signal; CFR 47 Part 15.215, 15.247(d) and RSS 247 Sect. 5.5: 2015.

The setup was identical to RF output power measurement.

This test was conducted on 3 channels on the EUT Model AT1UH1.

4.4.1 Results

As originally tested, the EUT was found to be compliant to the requirements of the test standard(s).

Table 5: Band Edge Requirements – Test Results BLE

Test Conditions: Conducted Measurement		Date: December 13, 2016		
Antenna Type: Integrated Antenna		Power Setting: Fixed		
Max. Antenna Gain: +0 dBi		Signal State: Modulated		
Duty Cycle: 98 %		Data Rate: Fixed		
Ambient Temp.: 21° C		Relative Humidity: 35 %RH		
-30 dBr Band Edge Results				
Operating Freq.	Carrier Peak level (dBm)	Limit (dBm)	Measured Value (dBm)	Result
2402 MHz	1.4	-28.6	-38.4	Pass
2480 MHz	0.8	-29.20	-47.2	Pass
Note: -				

Table 6: Out of Band Emissions– Test Results BLE

Out of Band Emission				
Operating Freq.	Carrier Peak level (dBm)	Limit (dBm)	Measured Value (dBm)	Result
2402 MHz	1.5	-28.5	-37.6	Pass
2440 MHz	-3.6*	-33.6*	-36.8	Pass
2480 MHz	0.9	-29.1	-36.7	Pass
Note: *Limit at 2440 MHz taken from Occupied Bandwidth marker reading.				

4.4.2 Band Edge Results

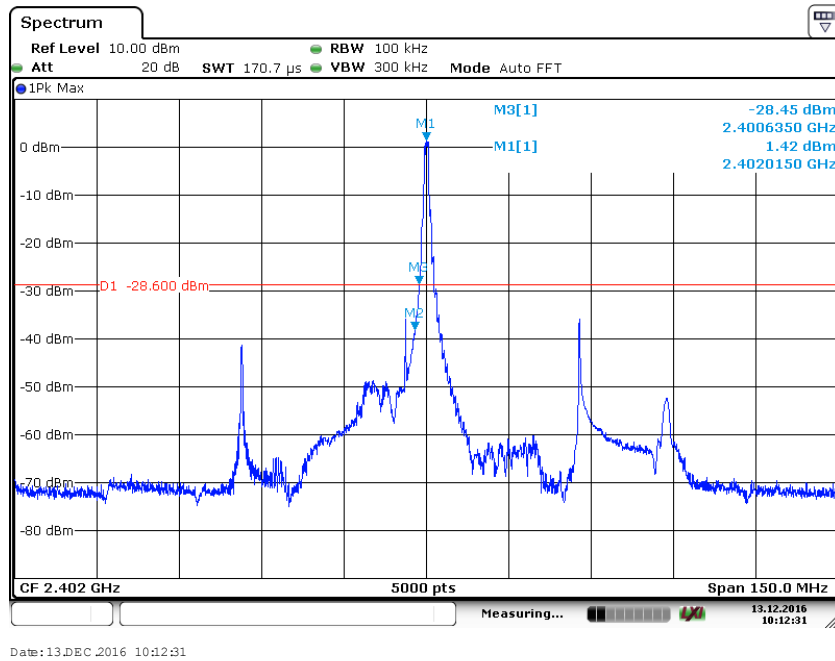

Figure 10: Band Edge Requirements at 2402 MHz

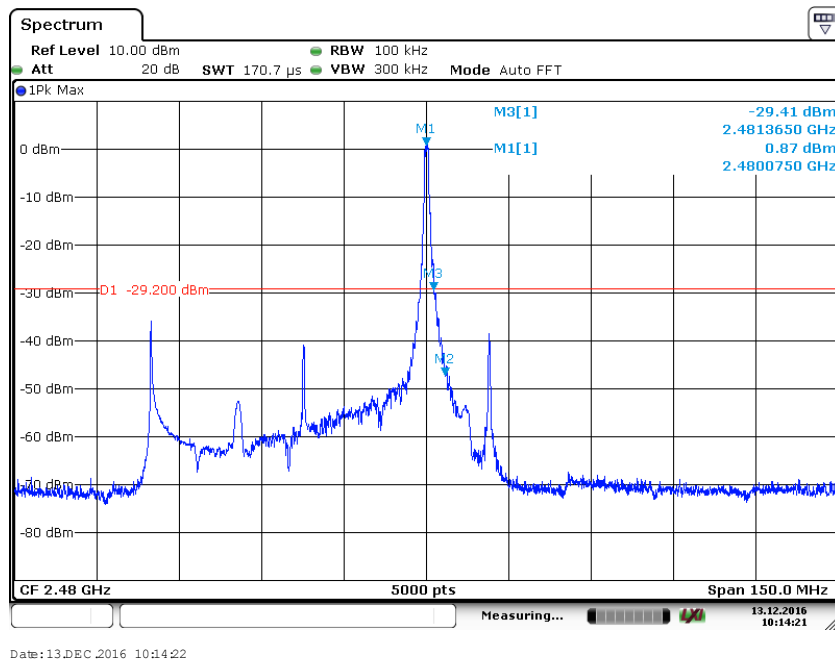

Figure 11: Band Edge Requirements at 2480 MHz

4.4.3 Out of Band Emissions

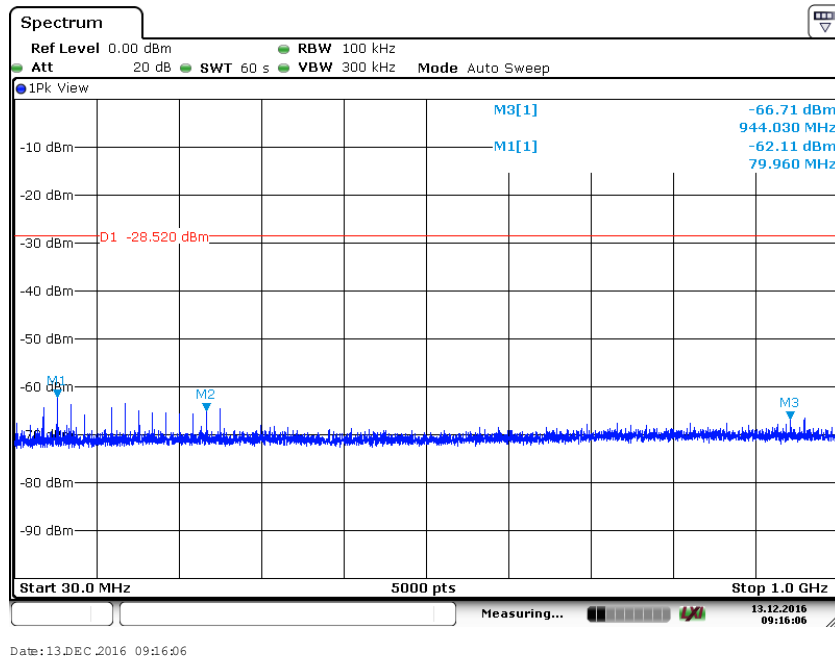

Figure 12: Out of Band Emission Requirements at 2402 MHz; 30 MHz – 1000 MHz

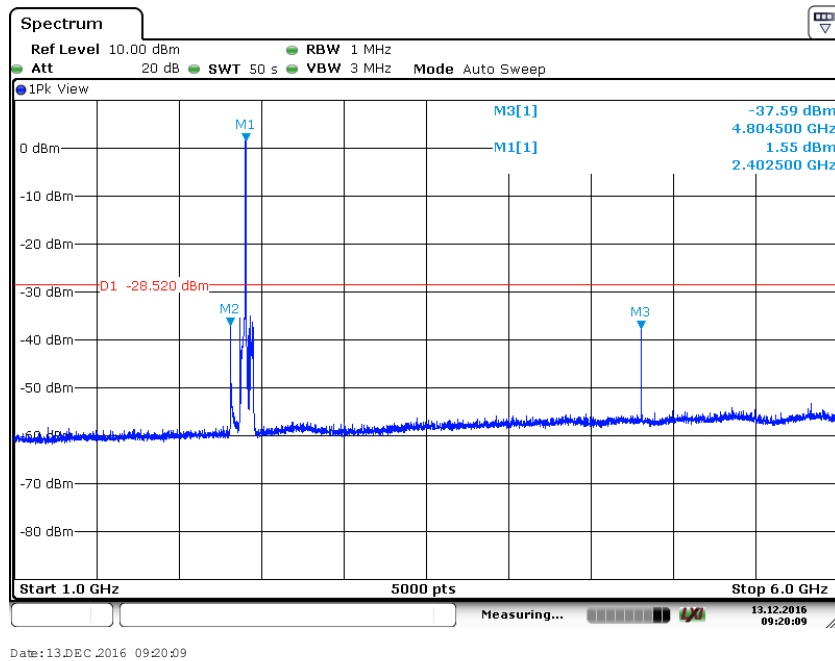

Figure 13: Out of Band Emission Requirements at 2402 MHz; 1 GHz – 6 GHz

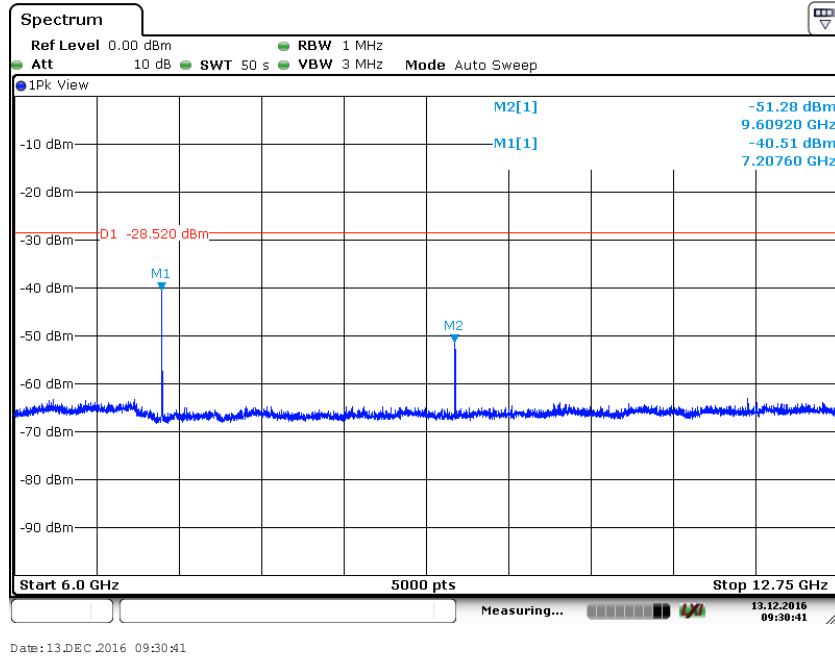

Figure 14: Out of Band Emission Requirements at 2402 MHz; 6 GHz – 12.75 GHz

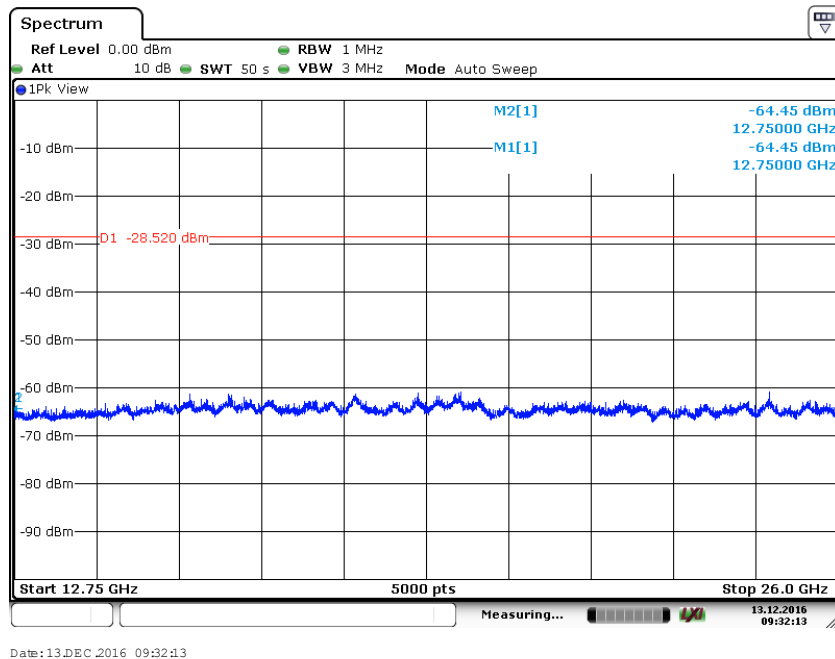
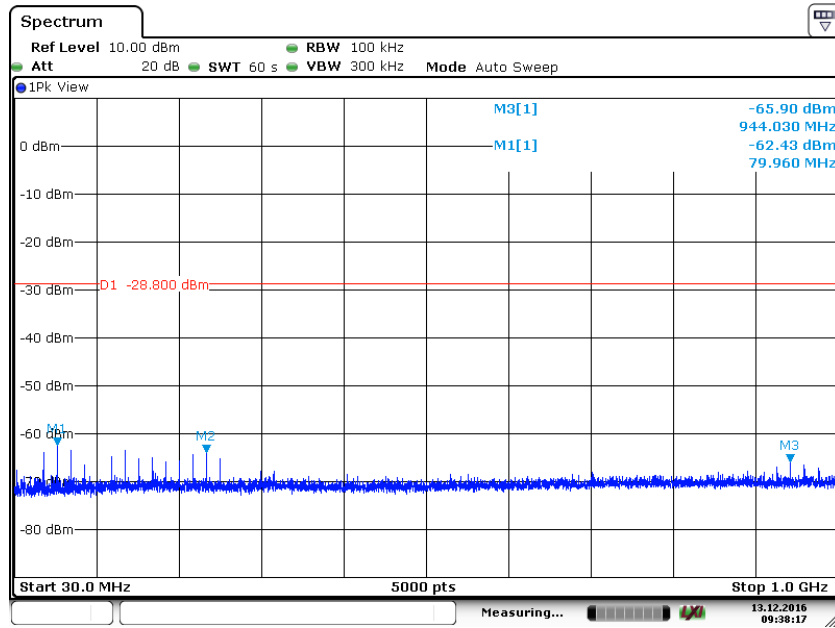
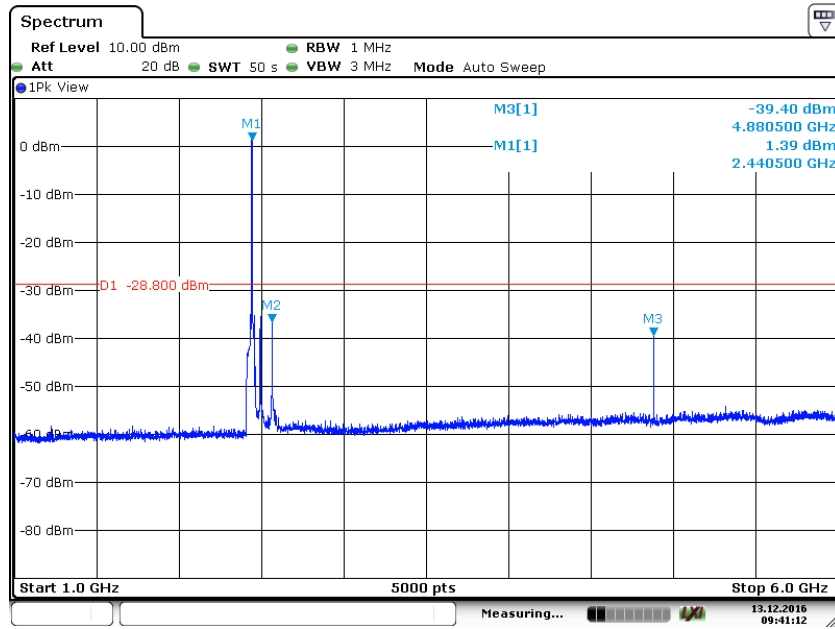

Figure 15: Out of Band Emission Requirements at 2402 MHz; 12.75 GHz – 26 GHz



Date: 13.DEC.2016 09:38:18

Figure 16: Out of Band Emission Requirements at 2440 MHz; 30 MHz – 1000 MHz



Date: 13.DEC.2016 09:41:12

Figure 17: Out of Band Emission Requirements at 2440 MHz; 1 GHz – 6 GHz

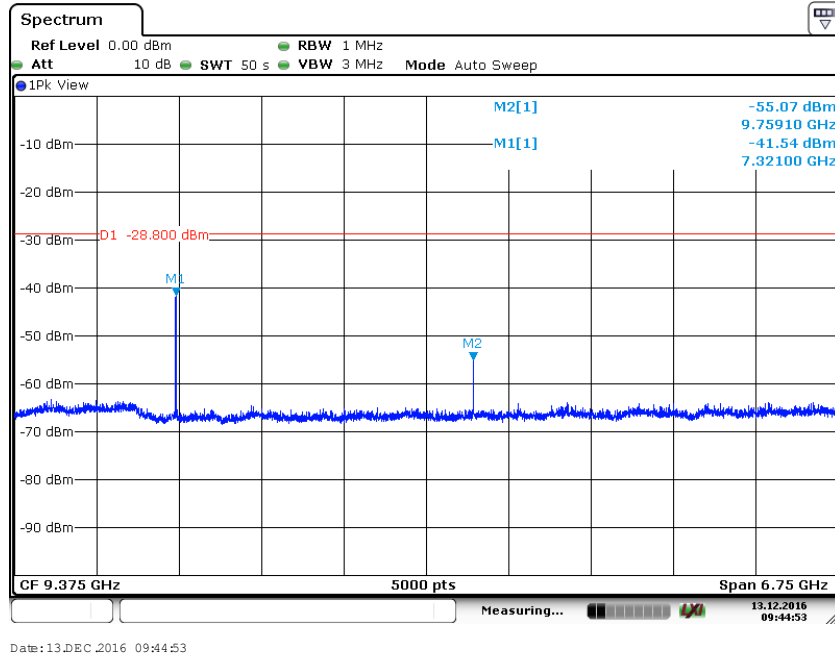

Figure 18: Out of Band Emission Requirements at 2440 MHz; 6 GHz – 12.75 GHz

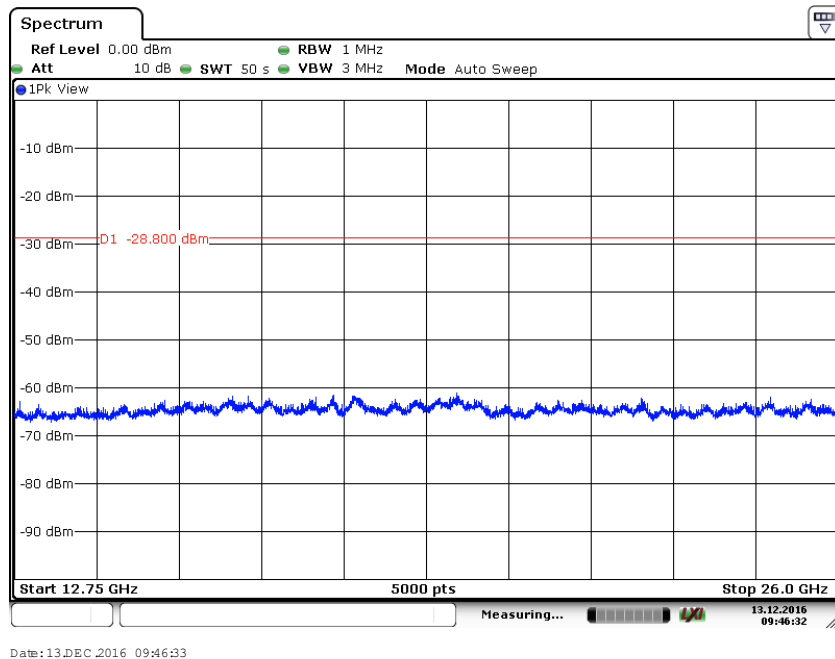
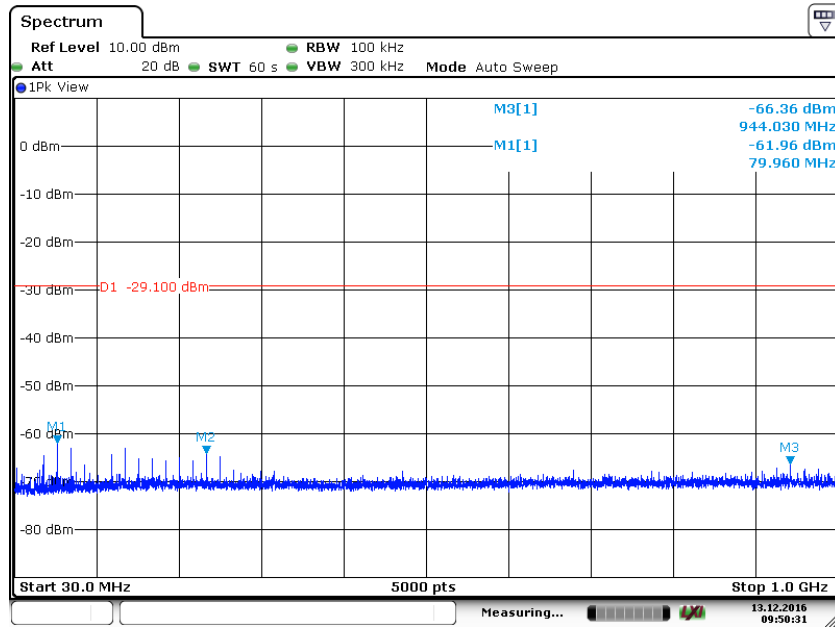
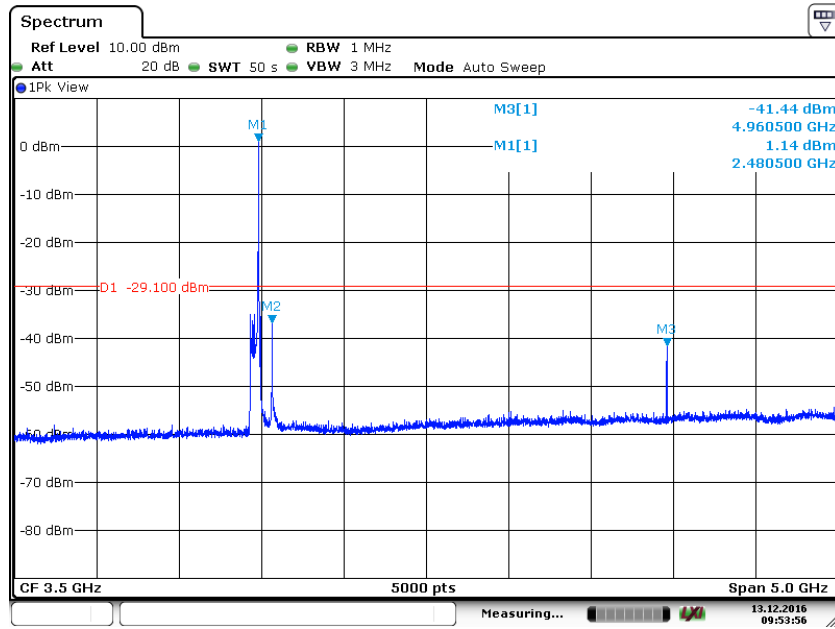

Figure 19: Out of Band Emission Requirements at 2440 MHz; 12.75 GHz – 26 GHz



Date: 13.DEC.2016 09:50:31

Figure 20: Out of Band Emission Requirements at 2480 MHz; 30 MHz – 1000 MHz



Date: 13.DEC.2016 09:53:57

Figure 21: Out of Band Emission Requirements at 2480 MHz; 1 GHz – 6 GHz

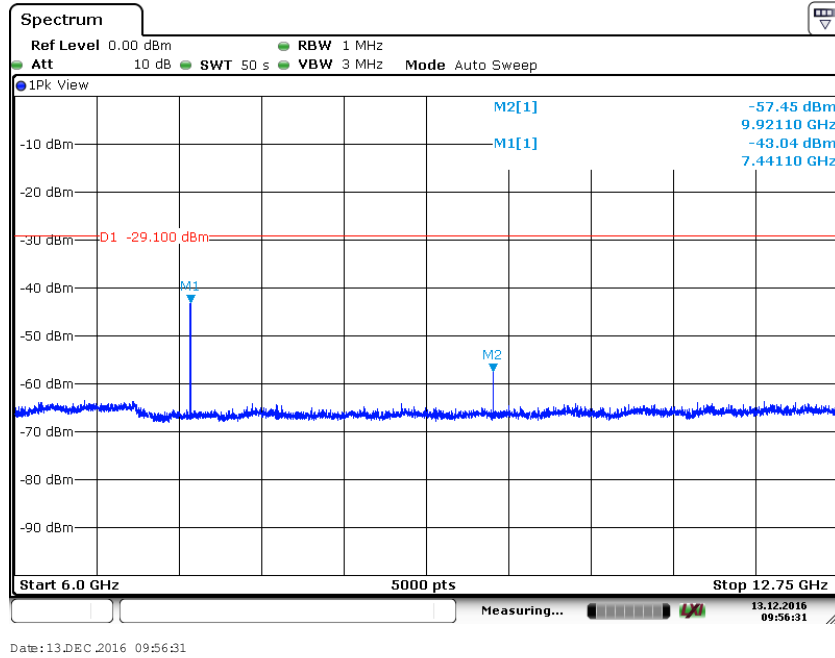

Figure 22: Out of Band Emission Requirements at 2480 MHz; 6 GHz – 12.75 GHz

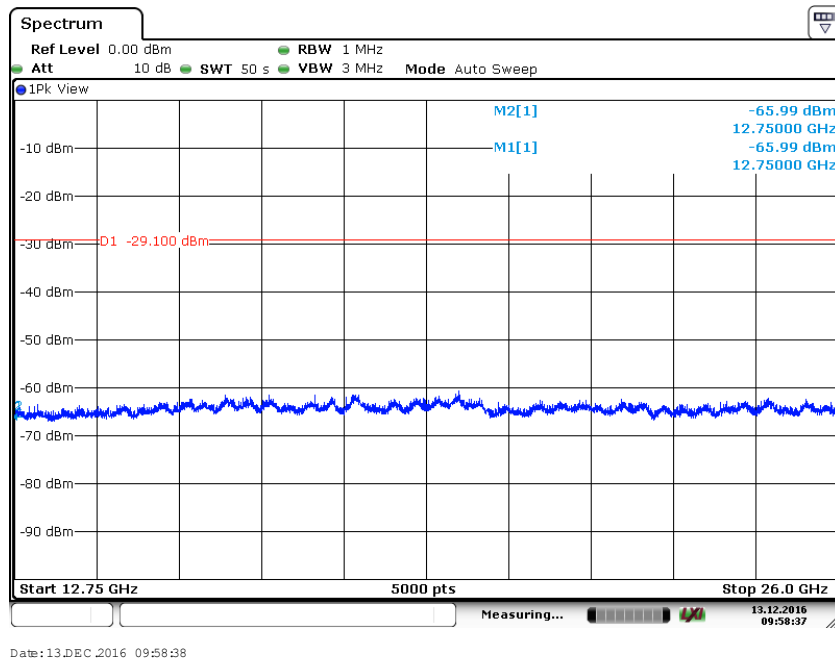

Figure 23: Out of Band Emission Requirements at 2480 MHz; 12.75 GHz – 26 GHz

4.5 Transmitter Spurious Emissions

Transmitter spurious emissions are emissions outside the frequency range of the equipment when the equipment is in transmitting mode; per requirement of CFR47 15.205, 15.209, 15.247(d), RSS 247 Sect. 5.5.

4.5.1 Test Methodology

4.5.1.1 Preliminary Test

A test program that controls instrumentation and data logging was used to automate the preliminary RF emission test procedure. The frequency range of interest was divided into sub-ranges to yield a frequency resolution of approximately 120 kHz and provide a reading at each frequency for no more than 12° of turntable rotation. For each frequency sub-range the turntable was rotated 360° while peak emission data was recorded and plotted over the frequency range of interest in horizontal and vertical antenna polarization's.

Preliminary emission profile testing was performed inside the anechoic chamber. The EUT was placed on a 1.0m x 1.5m non-conductive table 80cm (<1 GHz) and 150cm (>1 GHz) above the floor. The EUT was positioned as shown in the setup photographs. The receiving antenna was placed at a distance of 3m at a fixed height of 1m. Measurement equipment was located outside of the chamber. A video camera was placed inside the chamber to view the EUT. The pre-scans are executed under the utilization of the peak detector.

4.5.1.2 Final Test

For each frequency measured, the peak emission was maximized by manipulating the receiving antenna from 1 to 4 meters above the ground plane and placing it at the position that produced the maximum signal strength reading. The turntable was then rotated through 360° while observing the peak signal and placing the EUT at the position that produced maximum radiation. The six highest emissions relative to the limit were measured unless such emissions were more than 20 dB below the limit. If less than six emissions are within 20 dB of the limit, than the noise level of the receiver is measured at frequencies where emissions are expected. Multiples of all oscillator and microprocessor frequencies were also checked.

Final testing was performed on an NSA compliant test site. The EUT was placed on a 1.0m x 1.5m non-conductive table 80cm (<1 GHz) and 150cm (>1 GHz) above the ground plane. The placement of EUT and cables were the same as for preliminary testing and is shown in the setup photographs.

The final scans performed on the worst axis, Y-Axis, for three operating channels: 2402 MHz, 2440 MHz, and 2480 MHz for BLE mode.

4.5.1.3 Deviations

None.

Test Setup:

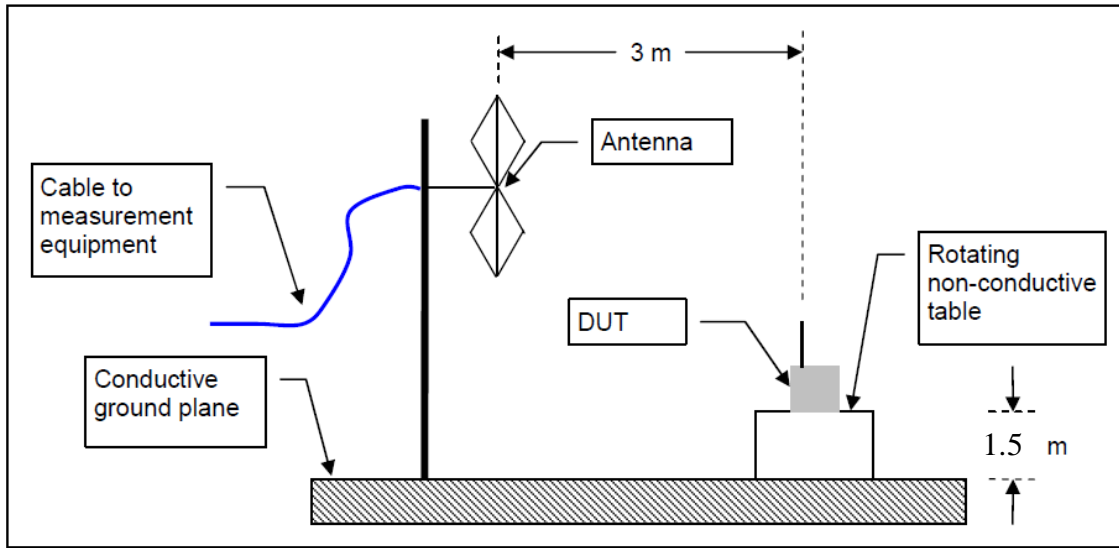

4.5.2 Transmitter Spurious Emission Limit

The spurious emissions of the transmitter shall not exceed the values in CFR47 Part 15.205, 15.209: 2016 and RSS Gen Sect. 8.9: 2015.

Frequency (MHz)	Field strength (microvolts/meter)	Measurement distance (meters)
0.009-0.490.....	2400/F (kHz)	300
0.490-1.705.....	24000/F (kHz)	30
1.705-30.0.....	30	30
30-88.....	100 **	3
88-216.....	150 **	3
216-960.....	200 **	3
Above 960.....	500	3

All harmonics and spurious emission which are outside of the restricted band shall be 20 dB below the in-band emission.

4.5.3 Test Results

The final measurement data was taken under the worst case operating modes, configurations, and/or cable positions. It also reflects the results including any modifications and/or special accessories listed in Sections 1.4 and Test Plan.

As originally tested, the EUT was found to be compliant to the requirements of the test standard(s).

No EUT emissions observed for frequencies < 30 MHZ.

Table 7: Transmit Spurious Emission at Restricted Band Edge Requirements

Test Conditions: Radiated Measurement at 3 meters					Date: December 12, 2016			
Antenna Type: Integrated					Power Setting: Fixed.			
Max. Antenna Gain: +0 dBi					Signal State: Modulated			
Duty Cycle: 98 %					Data Rate: see below			
Ambient Temp.: 21° C					Relative Humidity: 35 %RH			
Band Edge Results BLE								
Freq. MHz	Level dBuV/m	Pol. V/H	15.209/15.247		Detector Pk/Avg	Azimuth degrees	Height meters	Comments
			Limit	Margin				
2390	59.91	V	74	-14.09	Pk	256	192	TX at 2402 MHz
2390	48.21	V	54	-5.79	Avg	256	192	TX at 2402 MHz
2390	60.21	H	74	-13.79	Pk	164	200	TX at 2402 MHz
2390	48.21	H	54	-5.79	Avg	164	200	TX at 2402 MHz
2484	61.37	V	74	-12.63	Pk	166	223	TX at 2480 MHz
2484	46.28	V	54	-7.72	Avg	166	223	TX at 2480 MHz
2484	64.35	H	74	-9.65	Pk	244	222	TX at 2480 MHz
2484	46.28	H	54	-7.72	Avg	244	222	TX at 2480 MHz

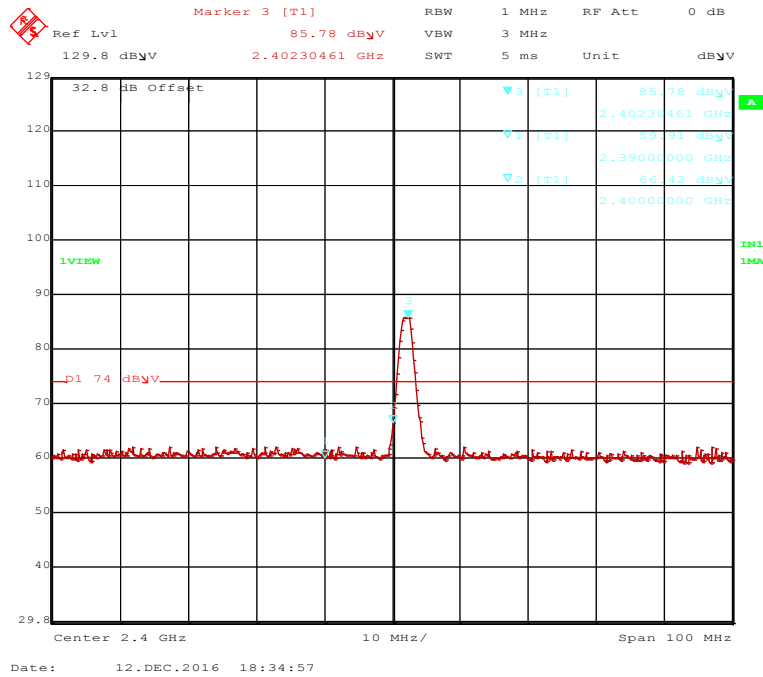

Figure 24: Radiated Emission at the 2390MHz Edge for Channel 2402 MHz –Vertical (Pk)

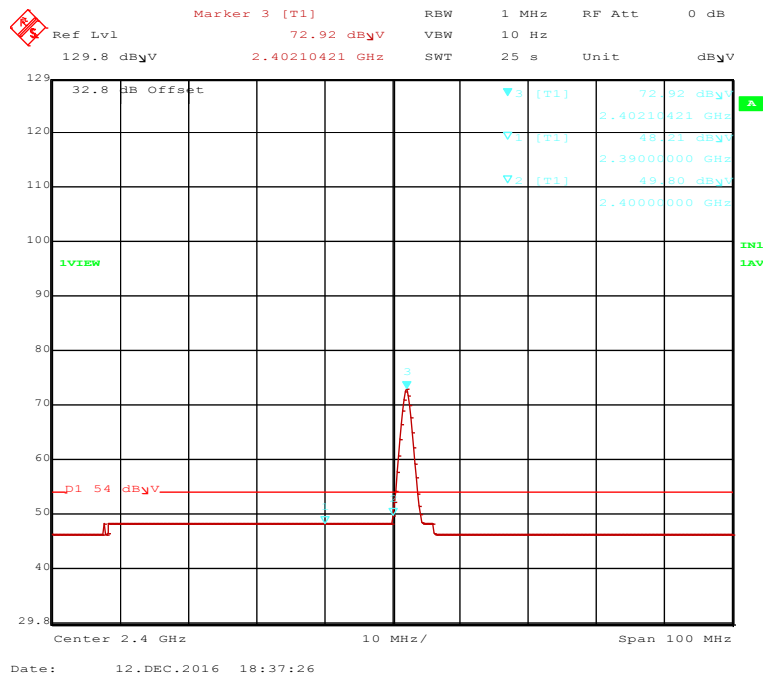

Figure 25: Radiated Emission at the 2390MHz Edge for Channel 2402 MHz – Vertical (Avg)

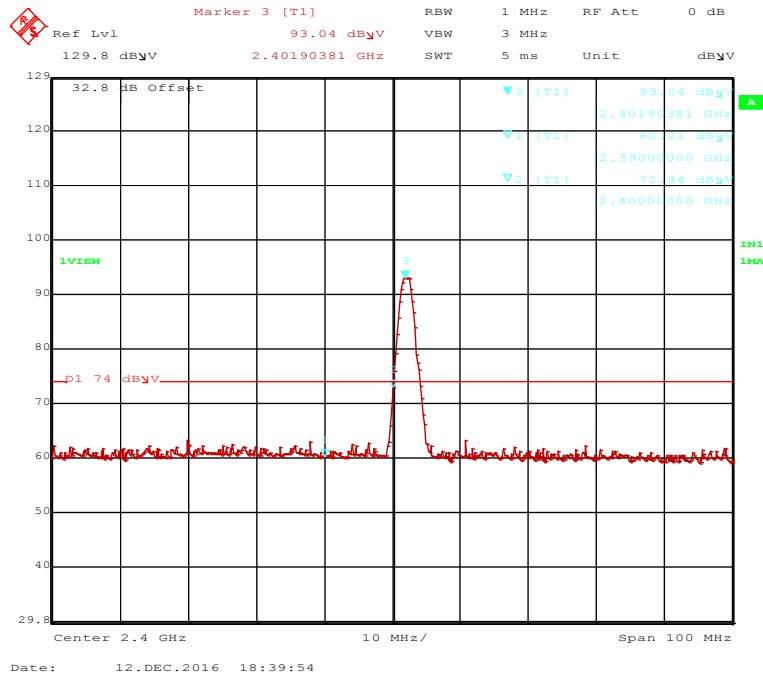

Figure 26: Radiated Emission at the 2390MHz Edge for Channel 2402 MHz – Horizontal (Pk)

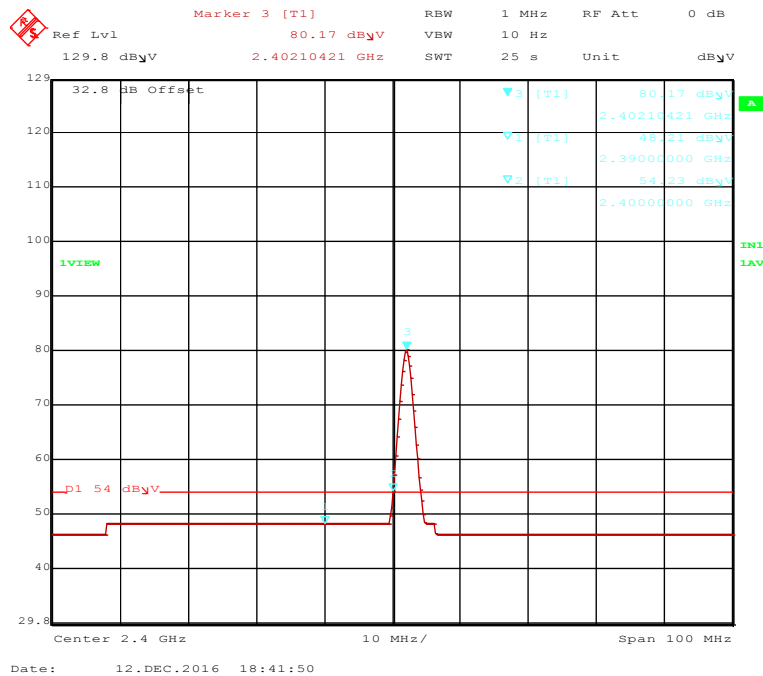

Figure 27: Radiated Emission at the 2390MHz Edge for Channel 2402 MHz – Horizontal (Avg)

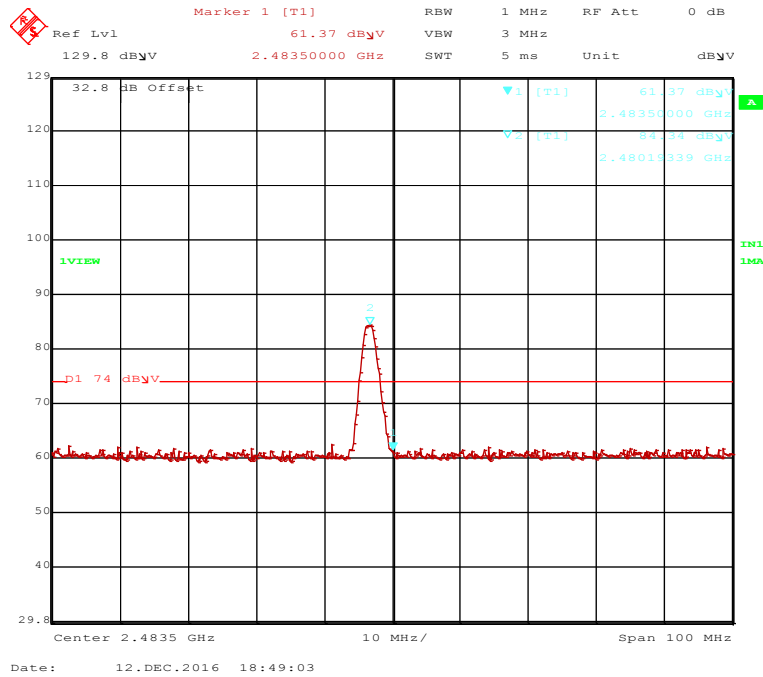

Figure 28: Radiated Emission at the 2483.5MHz Edge for Channel 2480 MHz – Vertical (Pk)

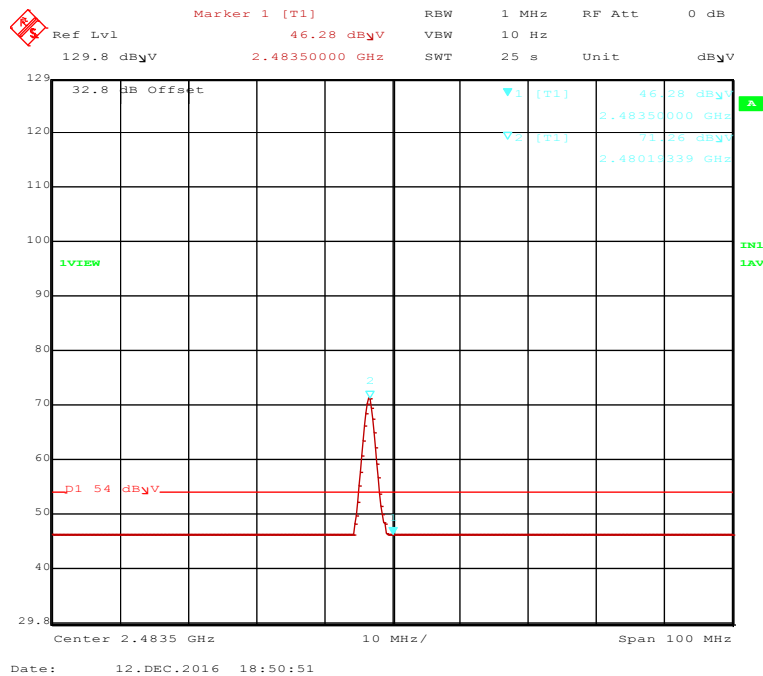

Figure 29: Radiated Emission at the 2483.5MHz Edge for Channel 2480 MHz – Vertical (Avg)

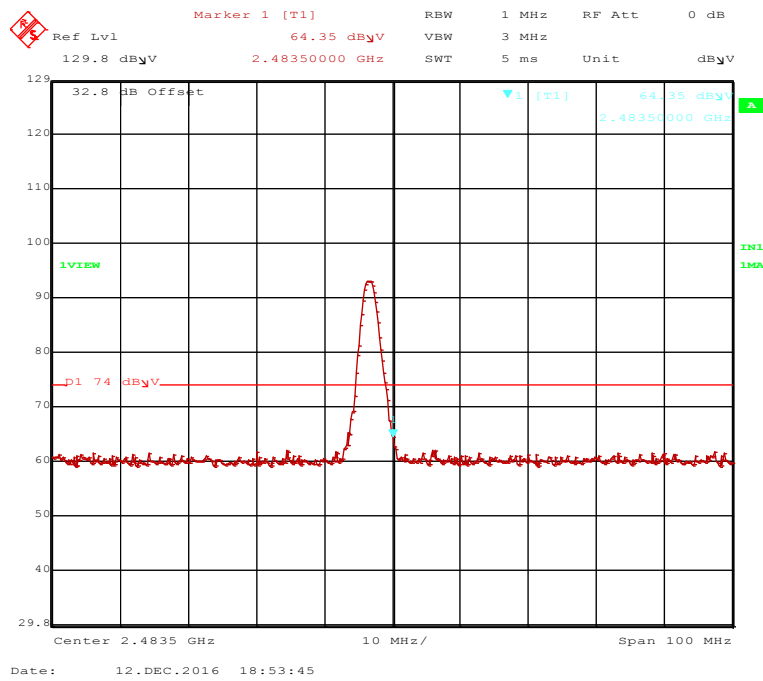

Figure 30: Radiated Emission at the 2483.5MHz Edge for Channel 2480 MHz at – Horizontal (Pk)

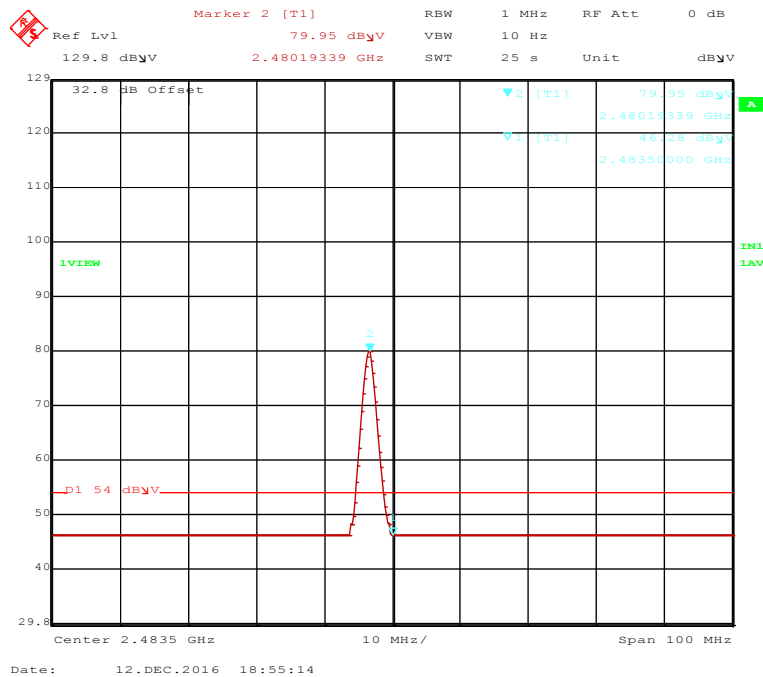
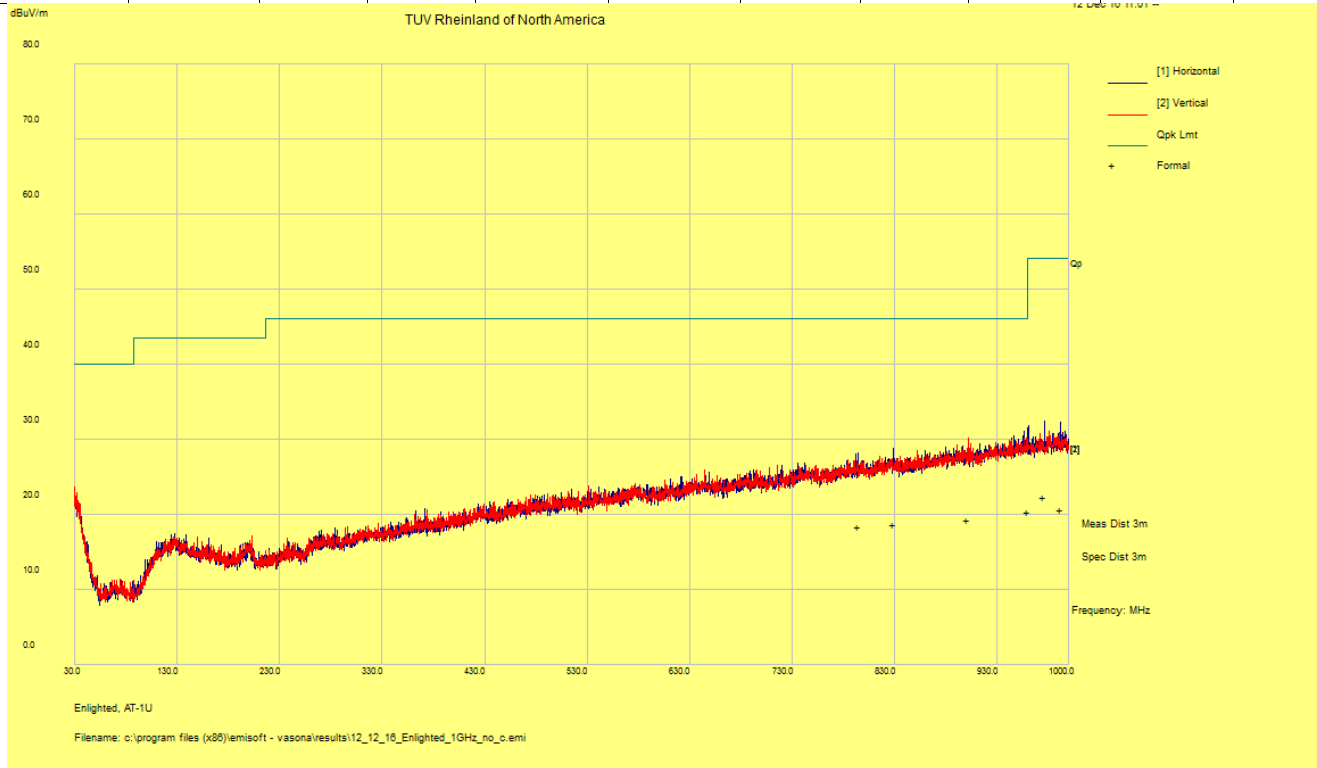

Figure 31: Radiated Emission at the 2483.5MHz Edge for Channel 2480 MHz – Horizontal (Avg)

Radiated Emissions				Page 1 of 7	
EUT Name	Asset Tracker			Date	December 12, 2016
EUT Model	AT-1U-H1			Temp / Hum in	21° C / 35%rh
EUT Serial	N/A			Temp / Hum out	N/A
EUT Config.	BLE on X-Axis			Line AC / Freq	N/A
Standard	CFR47 Part 15 Subpart C, RSS-247, RSS-GEN			RBW / VBW	120 kHz/ 300 kHz
Dist/Ant Used	3m / JB3			Performed by	BMJ

30 MHz – 1 GHz Transmit at 2440 MHz

Frequency	Raw	Cable Loss	AF	Level	Detector	Polarity	Height	Azimuth	Limit	Margin
MHz	dBuV/m	dB	dB	dBuV/m		H/V	cm	deg	dBuV/m	dB
794.33	20.40	3.83	-5.86	18.37	QP	H	128	198	46.00	-27.63
828.62	19.99	3.89	-5.19	18.69	QP	H	171	194	46.00	-27.31
901.64	19.61	4.02	-4.39	19.24	QP	H	170	24	46.00	-26.76
960.25	19.49	4.13	-3.20	20.42	QP	H	184	275	54.00	-33.58
976.06	20.95	4.14	-2.81	22.28	QP	H	100	232	54.00	-31.72
992.36	19.10	4.18	-2.60	20.68	QP	H	184	102	54.00	-33.32



Spec Margin = Level - Limit, Level = Raw + Cbl + CF ± Uncertainty; CF = Amp Gain + ANT Factor

Combined Standard Uncertainty $u_c(y) = \pm 4.52$ dB Expanded Uncertainty $U = k u_c(y)$ $k = 2$ for 95% confidence

Note: The worst case was observed at mid channel.
 All other emissions passed Class B limit.
 - The temporary serial connector, used for channel configurations, had to be removed to pass the emission tests. The temporary serial connector was installed for regulatory compliance test configurations and is not present in the final product.

Radiated Emissions				Page 2 of 7	
EUT Name	Asset Tracker			Date	December 08, 2016
EUT Model	AT-1U-H1			Temp / Hum in	21° C / 36%rh
EUT Serial	N/A			Temp / Hum out	N/A
EUT Config.	BLE on X-Axis			Line AC / Freq	N/A
Standard	CFR47 Part 15 Subpart C, RSS-247, RSS-GEN			RBW / VBW	1 MHz/ 3 MHz
Dist/Ant Used	3m / DRH-118 & 1m / AHA-840			Performed by	BMJ

1 – 18 GHz Transmit at 2402 MHz

Frequency	Raw	Cable Loss	AF	Level	Detector	Polarity	Height	Azimuth	Limit	Margin
MHz	dBuV/m	dB	dB	dBuV/m		H/V	cm	deg	dBuV/m	dB
1073.61	46.93	0.79	-28.32	19.40	Average Max	H	110	256	54.00	-34.60
4804.23	49.75	1.82	-20.11	31.46	Average Max	H	123	170	54.00	-22.54
7274.89	42.19	2.23	-15.95	28.47	Average Max	V	144	240	54.00	-25.53
8469.66	41.55	2.51	-14.13	29.93	Average Max	H	147	326	54.00	-24.07
9674.94	41.49	2.59	-13.40	30.68	Average Max	H	125	112	54.00	-23.32
11586.71	40.07	2.80	-11.90	30.96	Average Max	H	137	110	54.00	-23.04
13503.15	41.02	3.15	-10.27	33.91	Average Max	V	135	312	54.00	-20.09
14385.82	40.33	3.25	-8.40	35.19	Average Max	V	176	120	54.00	-18.82

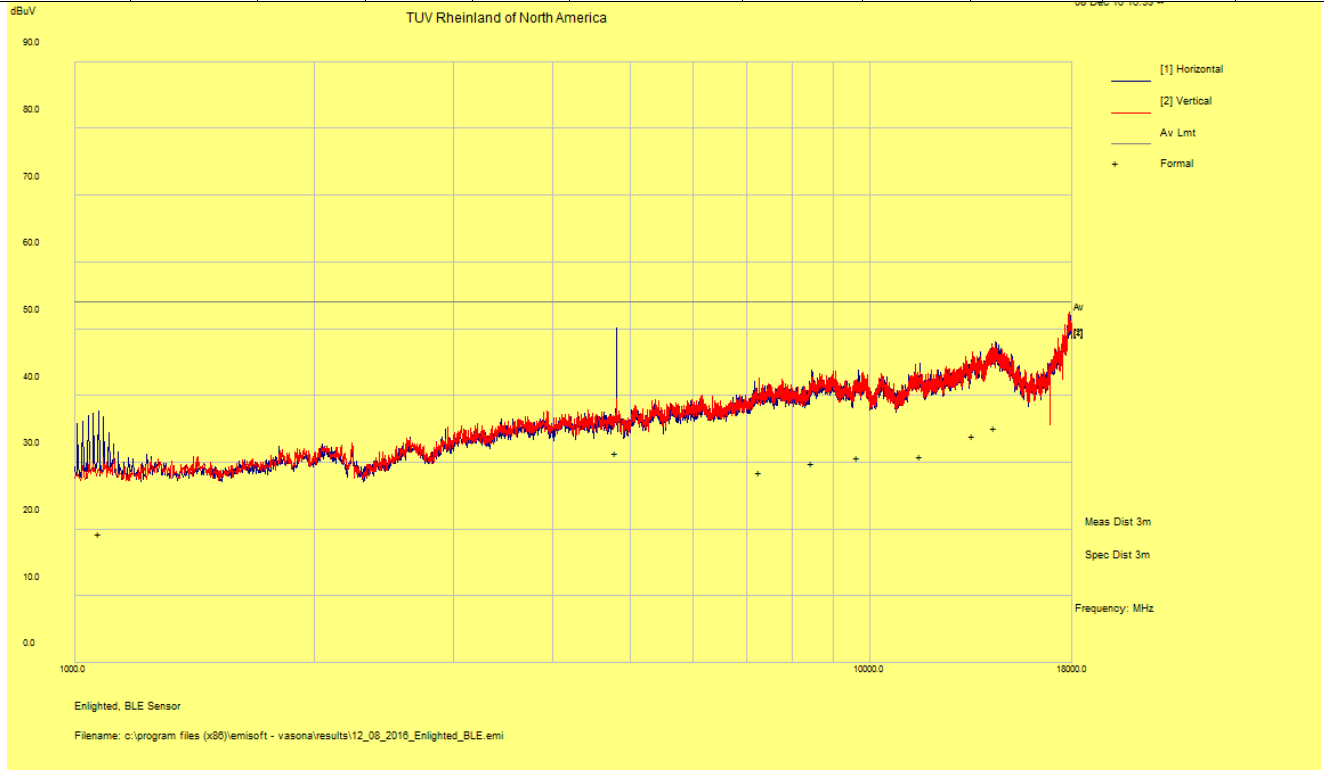

Spec Margin = Level - Limit, Level = Raw + Cbl + CF ± Uncertainty
 CF = Amp Gain + ANT Factor
 Combined Standard Uncertainty $u_c(y) = \pm 4.52$ dB Expanded Uncertainty $U = k u_c(y)$ $k = 2$ for 95% confidence
Note: All emissions passed the spurious emission limit. No significant emission was observed from 1GHz to 26GHz.

Radiated Emissions				Page 3 of 7	
EUT Name	Asset Tracker			Date	December 08, 2016
EUT Model	AT-1U-H1			Temp / Hum in	21° C / 36%rh
EUT Serial	N/A			Temp / Hum out	N/A
EUT Config.	BLE on X-Axis			Line AC / Freq	N/A
Standard	CFR47 Part 15 Subpart C, RSS-247, RSS-GEN			RBW / VBW	1 MHz/ 3 MHz
Dist/Ant Used	3m / DRH-118 & 1m / AHA-840			Performed by	BMJ

1 – 18 GHz Transmit at 2440 MHz

Frequency	Raw	Cable Loss	AF	Level	Detector	Polarity	Height	Azimuth	Limit	Margin
MHz	dBuV/m	dB	dB	dBuV/m		H/V	cm	deg	dBuV/m	dB
1040.01	45.01	0.78	-28.17	17.61	Average Max	H	116	292	54.00	-36.39
1747.92	43.76	1.02	-26.54	18.24	Average Max	H	179	116	54.00	-35.77
7623.97	41.87	2.28	-15.60	28.54	Average Max	V	184	330	54.00	-25.46
9862.97	41.12	2.60	-13.01	30.72	Average Max	H	191	256	54.00	-23.28
13506.44	40.96	3.15	-10.26	33.86	Average Max	V	140	252	54.00	-20.15
14346.61	40.25	3.24	-8.29	35.19	Average Max	V	113	212	54.00	-18.81
17828.04	39.92	3.88	-3.77	40.04	Average Max	V	142	54	54.00	-13.97

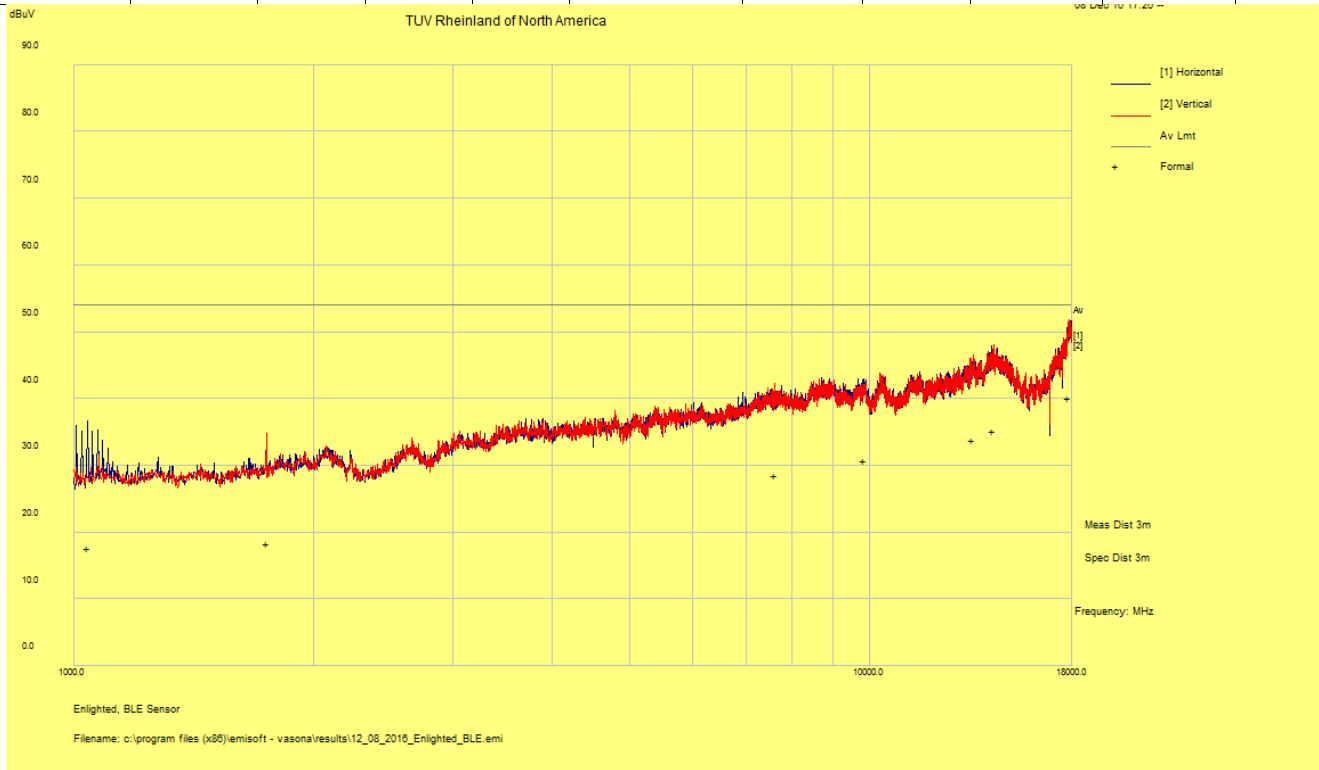

Spec Margin = Level - Limit, Level = Raw + Cbl + CF ± Uncertainty
 CF = Amp Gain + ANT Factor
 Combined Standard Uncertainty $u_c(y) = \pm 4.52$ dB Expanded Uncertainty $U = ku_c(y)$ $k = 2$ for 95% confidence
Note: All emissions passed the spurious emission limit. No significant emission was observed from 1GHz to 26GHz.

Radiated Emissions						Page 4 of 7	
EUT Name	Asset Tracker			Date	December 08, 2016		
EUT Model	AT-1U-H1			Temp / Hum in	21° C / 36%rh		
EUT Serial	N/A			Temp / Hum out	N/A		
EUT Config.	BLE on X-Axis			Line AC / Freq	N/A		
Standard	CFR47 Part 15 Subpart C, RSS-247, RSS-GEN			RBW / VBW	1 MHz/ 3 MHz		
Dist/Ant Used	3m / DRH-118 & 1m / AHA-840			Performed by	BMJ		

1 – 18 GHz Transmit at 2480 MHz

Frequency	Raw	Cable Loss	AF	Level	Detector	Polarity	Height	Azimuth	Limit	Margin
MHz	dBuV/m	dB	dB	dBuV/m		H/V	cm	deg	dBuV/m	dB
1040.18	55.69	0.78	-28.17	28.29	Average Max	H	150	126	54.00	-25.71
1645.80	44.66	0.98	-27.38	18.26	Average Max	H	145	332	54.00	-35.74
4959.67	44.35	1.86	-20.16	26.05	Average Max	H	140	224	54.00	-27.95
7440.92	42.73	2.27	-15.59	29.41	Average Max	H	122	162	54.00	-24.60
11518.91	40.22	2.78	-12.02	30.98	Average Max	H	179	236	54.00	-23.02
13722.49	39.81	3.15	-9.77	33.20	Average Max	H	150	32	54.00	-20.81
14108.90	40.11	3.14	-8.49	34.77	Average Max	H	101	-2	54.00	-19.23

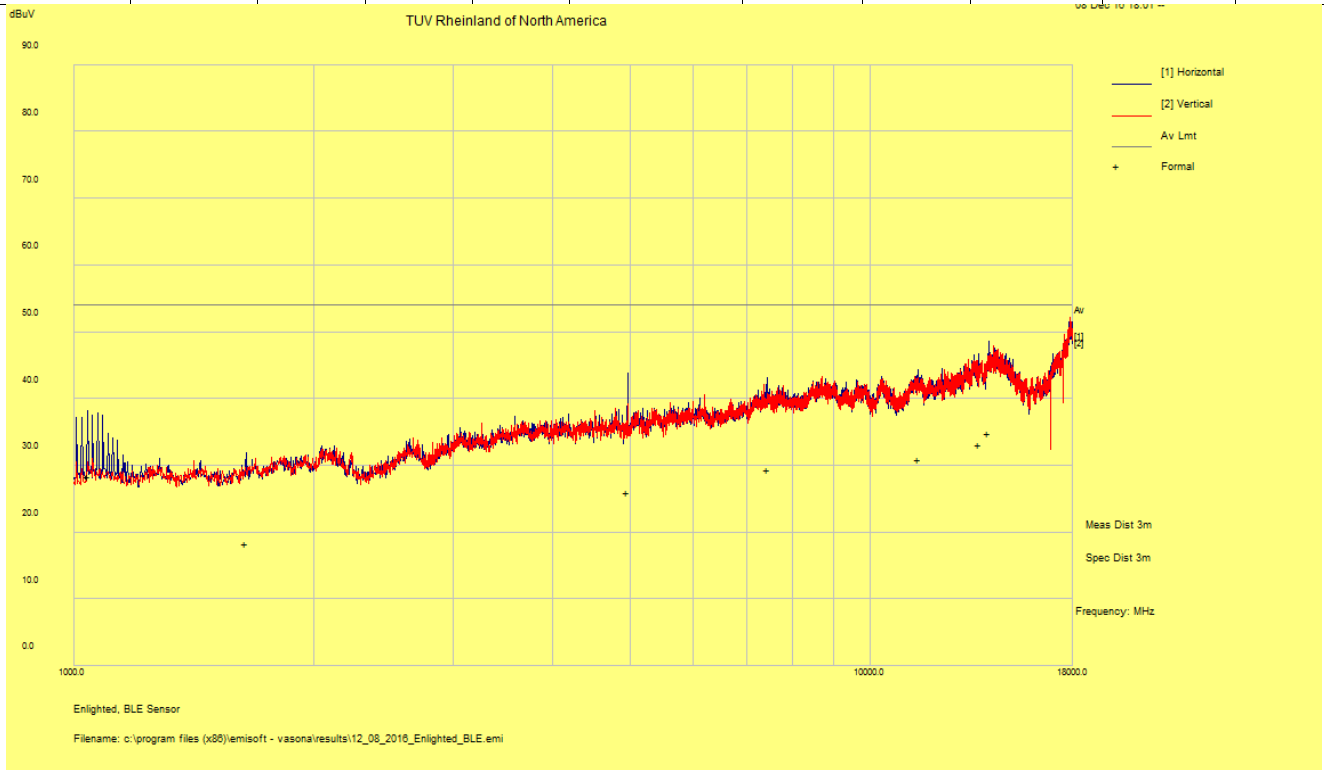

Spec Margin = Level - Limit, Level = Raw + Cbl + CF ± Uncertainty
 CF = Amp Gain + ANT Factor
 Combined Standard Uncertainty $u_c(y) = \pm 4.52$ dB Expanded Uncertainty $U = ku_c(y)$ $k = 2$ for 95% confidence
Note: All emissions passed the spurious emission limit. No significant emission was observed from 1GHz to 26GHz.

SOP 1 Radiated Emissions

EUT Name	Asset Tracker	Date	November 28, 2016
EUT Model	AT-1U-H1	Temp / Hum in	21° C / 36%rh
EUT Serial	N/A	Temp / Hum out	N/A
EUT Config.	BLE on X-Axis	Line AC / Freq	N/A
Standard	CFR47 Part 15 Subpart C, RSS-247, RSS-GEN	RBW / VBW	1 MHz/ 3 MHz
Dist/Ant Used	3m / DRH-118 & 1m / AHA-840	Performed by	BMJ

18 – 26 GHz Transmit at 2402 MHz

Frequency	Raw	Cable Loss	AF	Level	Detector	Polarit y	Height	Azimuth	Limit	Margin
MHz	dBuV/m	dB	dB	dBuV/m		H/V	cm	deg	dBuV/m	dB
20838.28	23.44	5.66	-9.09	20.01	Average Max	H	120	300	54.00	-33.99
25839.54	21.58	6.40	-12.87	15.11	Average Max	V	121	314	54.00	-38.89

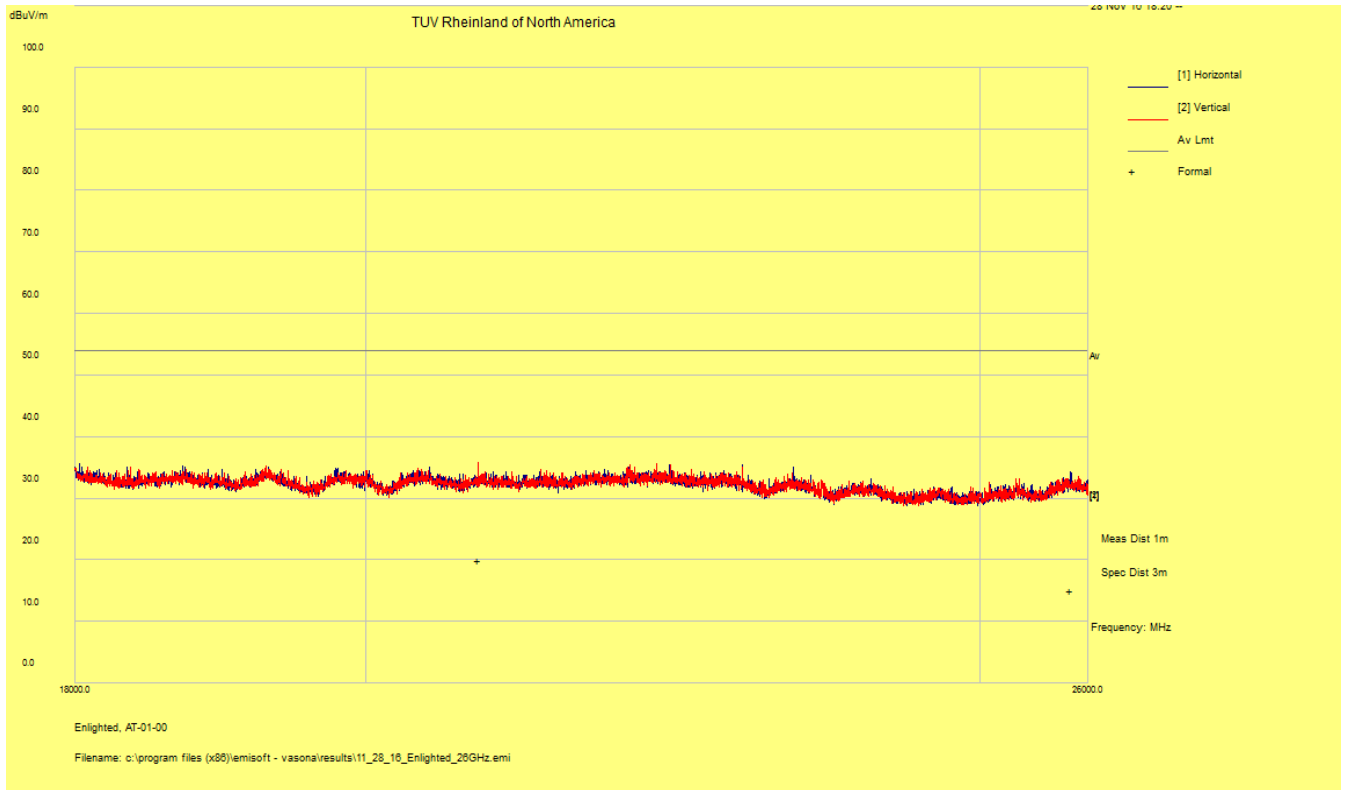

Spec Margin = Level - Limit, Level = Raw+ Cbl+ CF ± Uncertainty

CF= Amp Gain + ANT Factor

Combined Standard Uncertainty $u_c(y) = \pm 4.52$ dB Expanded Uncertainty $U = k u_c(y)$ $k = 2$ for 95% confidence

Note: All emissions passed the spurious emission limit. No significant emission was observed from 1GHz to 26GHz.

SOP 1 Radiated Emissions						Page 6 of 7	
EUT Name	Asset Tracker			Date	November 28, 2016		
EUT Model	AT-1U-H1			Temp / Hum in	21° C / 36%rh		
EUT Serial	N/A			Temp / Hum out	N/A		
EUT Config.	BLE on X-Axis			Line AC / Freq	N/A		
Standard	CFR47 Part 15 Subpart C, RSS-247, RSS-GEN			RBW / VBW	1 MHz / 3 MHz		
Dist/Ant Used	3m / DRH-118 & 1m / AHA-840			Performed by	BMJ		

18 – 26 GHz Transmit at 2480 MHz

Frequency	Raw	Cable Loss	AF	Level	Detector	Polarit y	Height	Azimuth	Limit	Margin
MHz	dBuV/m	dB	dB	dBuV/m		H/V	cm	deg	dBuV/m	dB
20363.70	23.09	8.46	-8.92	22.63	Average Max	H	117	62	54.00	-33.99
25771.43	21.36	10.04	-12.87	18.53	Average Max	V	120	240	54.00	-38.89

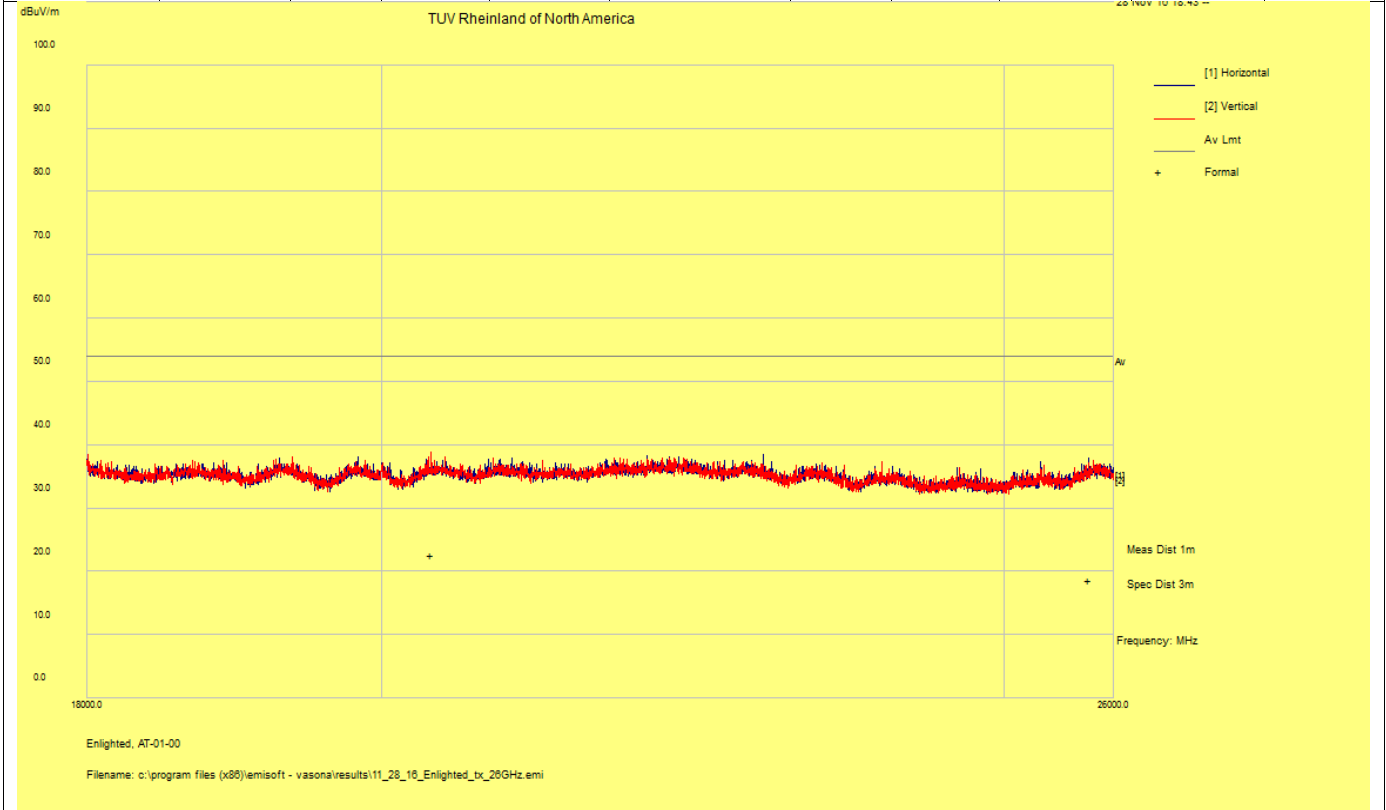

Spec Margin = Level - Limit, Level = Raw+ Cbl+ CF ± Uncertainty
 CF= Amp Gain + ANT Factor
 Combined Standard Uncertainty $u_c(y) = \pm 4.52$ dB Expanded Uncertainty $U = ku_c(y)$ $k = 2$ for 95% confidence
Note: All emissions passed the spurious emission limit. No significant emission was observed from 1GHz to 26GHz.

SOP 1 Radiated Emissions

EUT Name	Asset Tracker	Date	November 28, 2016
EUT Model	AT-1U-H1	Temp / Hum in	21° C / 36%rh
EUT Serial	N/A	Temp / Hum out	N/A
EUT Config.	BLE on X-Axis	Line AC / Freq	N/A
Standard	CFR47 Part 15 Subpart C, RSS-247, RSS-GEN	RBW / VBW	1 MHz/ 3 MHz
Dist/Ant Used	3m / DRH-118 & 1m / AHA-840	Performed by	BMJ

18 – 26 GHz Transmit at 2480 MHz

Frequency	Raw	Cable Loss	AF	Level	Detector	Polarit y	Height	Azimuth	Limit	Margin
MHz	dBuV/m	dB	dB	dBuV/m		H/V	cm	deg	dBuV/m	dB
20363.70	23.09	8.46	-8.92	22.63	Average Max	H	117	62	54.00	-33.99
25771.43	21.36	10.04	-12.87	18.53	Average Max	V	120	240	54.00	-38.89

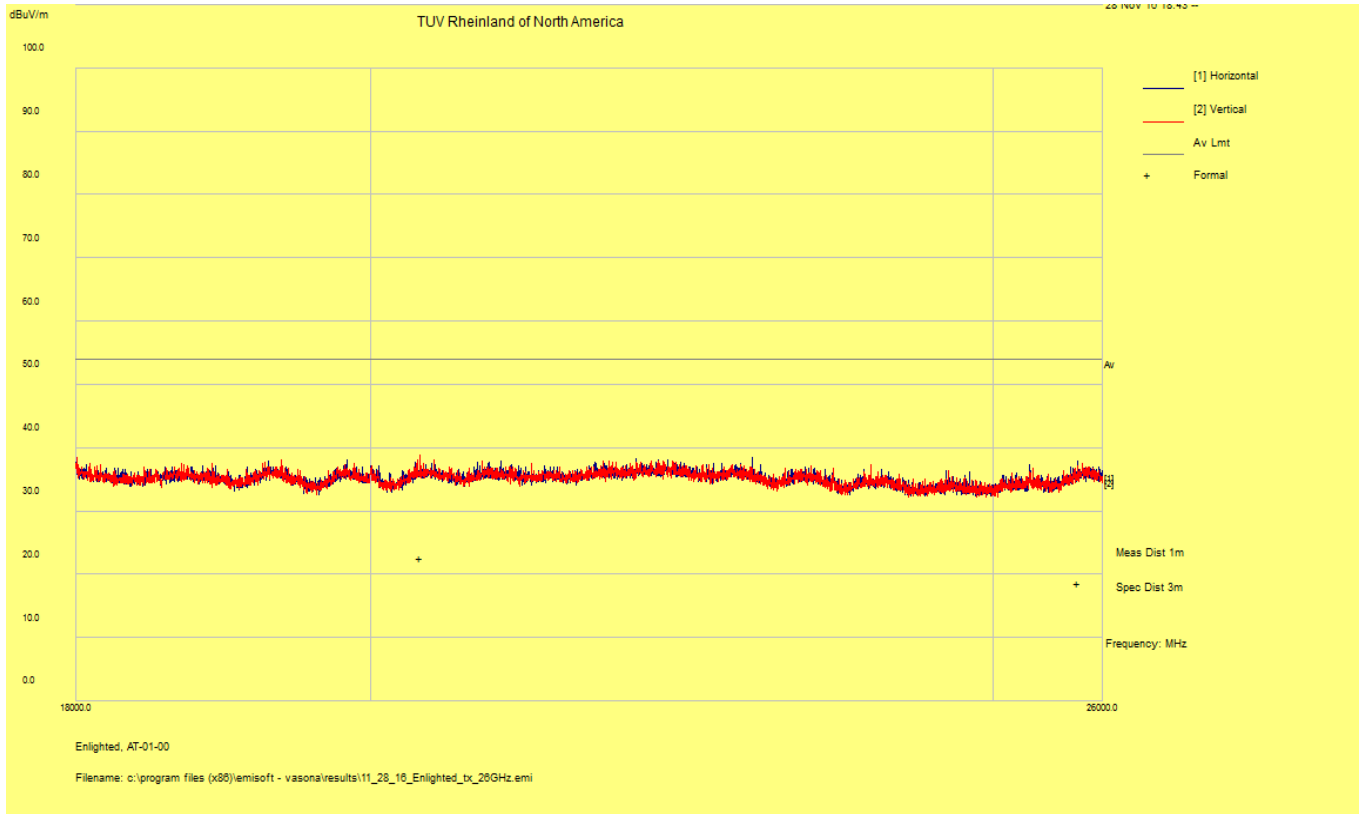

Spec Margin = Level - Limit, Level = Raw+ Cbl+ CF ± Uncertainty

CF= Amp Gain + ANT Factor

Combined Standard Uncertainty $u_c(y) = \pm 4.52$ dB Expanded Uncertainty $U = k u_c(y)$ $k = 2$ for 95% confidence

Note: All emissions passed the spurious emission limit. No significant emission was observed from 1GHz to 26GHz.

4.5.4 Sample Calculation

The field strength is calculated by subtracting the Amplifier Gain and adding the Cable Loss and Antenna Correction Factor to the measured reading. The basic equation is as follows:

$$\text{Field Strength (dB}\mu\text{V/m)} = \text{FIM} - \text{AMP} + \text{CBL} + \text{ACF}$$

Where:

FIM = Field Intensity Meter (dB μ V)

AMP = Amplifier Gain (dB)

CBL = Cable Loss (dB)

ACF = Antenna Correction Factor (dB/m)

$$\mu\text{V/m} = 10^{\frac{\text{dB}\mu\text{V/m}}{20}}$$

4.6 Maximum Permissible Exposure

4.6.1 Test Methodology

In this document, we try to prove the safety of radiation harmfulness to the human body for our product. The limit for Maximum Permissible Exposure (MPE) specified in FCC 1.1310 is followed. The Gain of the antenna used in this product is measured in a Semi-Anechoic Chamber, and also the maximum total power input to the antenna is measured. Through the Friis transmission formula and the maximum gain of the antenna, we can calculate the distance, away from the product, where the limit of MPE is reached.

Although the Friis transmission formula is a far field assumption, the calculated result of that is an over-prediction for near field power density. We will take that as the worst case to specify the safety range.

4.6.2 RF Exposure Limit

According to FCC 1.1310 table 1: The criteria listed in the following table shall be used to evaluate the environmental impact of human exposure to radio-frequency (RF) radiation as specified in 1.1307(b).

LIMITS FOR MAXIMUM PERMISSIBLE EXPOSURE (MPE)

Frequency Range (MHz)	Electric Field Strength (V/m)	Magnetic Field Strength (A/m)	Power Density (mW/cm ²)	Average Time (minutes)
(A)Limits For Occupational / Control Exposures				
300 - 1500	F/300	6
1500 - 100,000	5	6
(B)Limits For General Population / Uncontrolled Exposure				
300 - 1500	F/1500	6
1500 - 100,000	1.0	30

F = Frequency in MHz

4.6.3 EUT Operating Condition

The software provided by Manufacturer enabled the EUT to transmit data at lowest, middle and highest channel individually.

4.6.4 Classification

The antenna of the product, under normal use condition, is at least 20cm away from the body of the user. Warning statement to the user for keeping at least 20cm or more separation distance with the antenna should be included in user's manual. So, this device is classified as a **Mobile Device**.

4.6.5 Test Results

4.6.5.1 Antenna Gain

The transmitting antenna was integrated. The antenna gain was +0.0 dBi or 1 (numeric).

4.6.5.2 Output Power into Antenna & RF Exposure value at distance 20cm:

Calculations for this report are based on highest power measurement.

Limit for MPE (from FCC part 1.1310 table1) is 1.0 mW/cm²

The highest BLE measured power is +2.38 dBm; average power.

Using the Friss transmission formula, the EIRP is Pout*G, and R is 20cm.

$P_d = (1.73 * 1) / (1600\pi) = 0.0003441 \text{ mW/cm}^2$, which is 0.9997 mW/cm² below to the limit.

As originally tested, the EUT was found to be compliant to the requirements of the test standard(s).

ISED exemption limit $1.31 \times 10^{-2} * f^{0.6834}$

For $f = 2480 \text{ Mhz}$; ISED = 2.735518 W

Maximum EIRP below exemption limit.

4.6.6 Sample Calculation

The Friss transmission formula: $P_d = (P_{out} * G) / (4 * \pi * R^2)$

Where;

P_d = power density in mW/cm²

P_{out} = output power to antenna in mW

G = gain of antenna in linear scale

$\pi \approx 3.1416$

R = distance between observation point and center of the radiator in cm

Ref. : David K. Cheng, Field and Wave Electromagnetics, Second Edition, Page 640, Eq. (11-133).

5 Test Equipment Use List

5.1 Equipment List

Equipment	Manufacturer	Model #	Serial/Inst #	Last Cal mm/dd/yyyy	Next Cal mm/dd/yyyy
Bilog Antenna	Sunol Sciences	JB3	A020502	04/30/2015	04/30/2017
Horn Antenna	EMCO	3115	9710-5301	07/03/2015	07/03/2017
Horn Antenna	Sunol Science	DRH118	A040806	02/10/2015	02/10/2017
Horn Antenna	AH Systems	SAS-571	752	01/28/2016	01/28/2017
Spectrum Analyzer	Agilent	N9038A	MY51210195	01/26/2016	01/26/2017
Spectrum Analyzer	Agilent	N9030A	MY51380689	01/19/2015	01/19/2017
Spectrum Analyzer	Rohde & Schwartz	ESI	8392831005	01/19/2016	01/19/2017
Spectrum Analyzer	Rohde & Schwartz	FSV 40	15155-01-00	08/30/2016	08/30/2017
Amplifier	Sonoma Instruments	310	213221	01/18/2016	01/18/2017
Amplifier	Miteq	TTA1800-30-4G	1842452	01/20/2016	01/20/2017
Power Meter	Agilent	E3634A	MY400004331	01/19/2016	01/19/2017
Power Sensor	Hewlett Packard	8482A	US37295801	01/19/2016	01/19/2017
DC Power Supply	Agilent	E3634A	MY400004331	01/19/2016	01/19/2017
Notch Filter	Micro-Tronics	BRM50702	003	01/30/2016	01/30/2017
Signal Generator	Anritsu	MG3694A	42803	01/19/2016	01/19/2017

6 EMC Test Plan

6.1 Introduction

This section provides a description of the Equipment Under Test (EUT), configurations, operating conditions, and performance acceptance criteria. It is an overview of information provided by the manufacturer so that the test laboratory may perform the requested testing.

6.2 Customer

Table 8: Customer Information

Company Name	Enlighted , Inc.
Address	930 Benecia Avenue
City, State, Zip	Sunnyvale
Country	U.S.A.

Table 9: Technical Contact Information

Name	Deepak Kumar
E-mail	deepak.kumar@enlightedinc.com
Phone	+1-650-964-1094

6.3 Equipment Under Test (EUT)

Table 10: EUT Specifications

EUT Specifications	
Package Dimensions	10.0 mm height x 32.0 mm length x 70.0 width
Input Voltage	Input Voltage: 3 Vdc
Environment	Indoor
Operating Temperature Range:	-10 to +55 degrees C
Multiple Feeds:	<input type="checkbox"/> Yes and how many <input checked="" type="checkbox"/> No
Hardware Version	1.0
RF Software Version	nRFGo Studio V1.21.2.0 (DTM configuration)
Bluetooth Radio	
Operating Mode	BLE
Transmitter Frequency Band	2402 MHz to 2480 MHz
Operating Bandwidth	1.5 MHz
Max. Power Output	+2.38 dBm
Antenna Type	1 integrated PCB antenna
Antenna Gain	0.0 dBi
Modulation Type	GFSK
Data Rate	1Mbps
Note: This report only documents the radio characteristics for 2402 - 2480 MHz bands.	

Table 11: Interface Specifications

Interface Type	Cabled with what type of cable?	Is the cable shielded?	Maximum potential length of the cable?	Metallic (M), Coax (C), Fiber (F), or Not Applicable?
N/A*	N/A	<input type="checkbox"/> No	<input type="checkbox"/> Metric: 1 m	<input type="checkbox"/> M

* EUT set into RF configurations via temporary serial interface connection to access DTM (BT – Direct Test Mode)

Table 12: Supported Equipment

Equipment	Manufacturer	Model	Serial	Used for
Laptop	Lenovo	80FF G70-80	PF0DJA2Q	Setup EUT operating channel
Interface Board	Texas Instruments	CC Debugger	NA	Access BLE radio chipset
Software	Nordic semiconductor	nRFgo Studio	V1.21.2.0	DTM commands for Tx configuration
Note: None.				

Table 13: Description of Sample used for Testing

Device	Serial	RF Connection	CFR47 Part 15.247
AT-1U-H1	N/A	Integrated Antenna	Radiated Emissions, Radiated band Edge
	N/A	Direct via SMA Connection	Transmit Power, Occupied Bandwidth, Out of Band Emission, PSD

Table 14: Description of Test Configuration used for Radiated Measurement.

Device	Antenna	Mode	Setup Photo (X-Axis)	Setup Photo (Y-Axis)	Setup Photo (Z-Axis)
AT-1U-H1	Integrated	Transmit BLE mode	Flat on the table	Vertical	Parallel to Table
Note: The AT-1U-H1 is designed and intended to be mounted on variable packages, devices etc. for location tracking. Preliminary tests showed that Highest emissions were found in X axis for BLE.					

Table 15: Final Test Mode for 2402 MHz to 2480MHz Channels

Test	802.11 BLE Mode
Occupied Bandwidth CFR 47 15.247(a1), RSS Gen Sect. 6.6.	2402, 2440, 2480 MHz
Output Power CFR47 15.247 (b1), RSS 247 Sect. 5.4.2	2402, 2440, 2480 MHz
Out of Band Emission CFR47 15.247 (d), RSS 247 Sect. 6.2.1.2	2402, 2440, 2480 MHz
Band-Edge (Radiated) FCC Part 15.205, 15.209, RSS 247 Sect. 5.5	2402, 2480 MHz
Transmitted Spurious Emission (30 MHz – 1GHz) FCC Part 15.205, 15.209, RSS 247 Sect. 5.5	2440 MHz
Transmitted Spurious Emission (Above 1GHz) FCC Part 15.205, 15.209, RSS 247 Sect. 5.5	2402, 2440, 2480 MHz
<p>Note: 1. All radiated emission performed on X-Axis. 3. All tests were pre-scanned for worst case before final testing.</p>	

6.4 Test Specifications

Testing requirements

Table 16: Test Specifications

Emissions and Immunity	
Standard	Requirement
CFR 47 Part 15.247: 2016	All
RSS-247 Issue 1, 2015	All

END OF REPORT