

TEST REPORT

Report No.: SRTC2024-9004(F)-24081205(M)
Product Name: Smart Phone
Applicant: SHARP CORPORATION
Manufacturer: SHARP CORPORATION
Specification: FCC Part15C (Certification)
(2023 edition)
FCC ID: APYHRO00333

The State Radio_monitoring_center Testing Center (SRTC)
15th Building, No.30 Shixing Street, Shijingshan District,
Beijing, China
Tel: 86-10-57996183 Fax: 86-10-57996388

CONTENTS

1. General information	3
1.1 Notes of the test report.....	3
1.2 Information about the testing laboratory	3
1.3 Applicant's details	3
1.4 Manufacturer's details	3
1.5 Application details	4
1.6 Reference specification	4
1.7 Information of EUT	4
1.7.1 General information	4
1.7.2 EUT details	4
1.7.3 Auxiliary equipment details	5
1.7.4 Operation Mode	5
2. Test information	6
2.1 Summary of the test results	6
2.2 Test result	7
2.2.1 Conducted Emissions-FCC Part15.207	7
2.2.2RadiatedEmissions-FCC Part15.209	11
2.2.3 20dB Bandwidth and 99% Bandwidth	17
2.3. List of test equipments	19

1. General information

1.1 Notes of the test report

The test report may only be reproduced or published in full. Reproduction or publication of extracts from the report requires the prior written permission of The State Radio_monitoring_center Testing Center (SRTC).

The test results relate only to individual items of the samples which have been tested.

1.2 Information about the testing laboratory

Company: The State Radio_monitoring_center Testing Center (SRTC)
Test Site 1: 15th Building, No.30 Shixing Street, Shijingshan District
Test Site 2: No.80, Zhaojiachang, Beizang, Daxing District
City: Beijing
Country or Region: P.R.China
Contacted person: Liu Jia
Tel: +86 10 57996183
Fax: +86 10 57996388
Email: liujiaf@srtc.org.cn
Designation Number: CN1267
Registration number: 239125

1.3 Applicant's details

Company: SHARP CORPORATION
Address: 1 Takumi-cho, Sakai-ku, Sakai City, Osaka 590-8522, Japan
City: Osaka
Country or Region: Japan
Contacted person: Mr. Taihei Ohtsuka
Tel: +81-50-5433-4157
Email: ---

1.4 Manufacturer's details

Company: SHARP CORPORATION
Address: 1 Takumi-cho, Sakai-ku, Sakai City, Osaka 590-8522, Japan
City: Osaka
Country or Region: Japan
Contacted person: Mr. Taihei Ohtsuka
Tel: +81-50-5433-4157
Email: ---

1.5 Application details

Date of reception of test sample: 12st August 2024
 Date of test: 13th August 2024 to 13th September 2024

1.6 Reference specification

FCC Part 15C 2023 (Certification)

1.7 Information of EUT

1.7.1 General information

Model Name of EUT	APYHRO00333
Operating Frequency range	Charging stand: 110-148kHz
Test condition of declaration	Normal
Telecommunication center	<input type="checkbox"/> Yes <input checked="" type="checkbox"/> No
S/N	/
HW Version	DVT
SW Version	A718G

1.7.2 EUT details

Product Name	Model Name	IMEI
Smart Phone	APYHRO00333	EUT1:004401231775228/004401231800224 EUT2:004401231778750/004401231803756

P9 multi-Vendor List

	UFS memory		DDR	
	1st	KIOXIA	1st	MICRON
1st Source		THGJFLT2E46BATP		MT62F1536M64D8CL-023 WT:B
2nd Source	2nd	SAMSUNG	2nd	SAMSUNG
		KLUFG8RHHD-B0G1		K3KL4L40EM-BGCU

Note1: The above is a description of the differences between EUT1 and EUT2.

1.7.3 Auxiliary equipment details

AE (Auxiliary Equipment) 1#: Wireless Charging

Manufacturer	ELECOM
Model Number	W-QA02BK
Input Voltage	5V/2A
Output Voltage	---

AE (Auxiliary Equipment) 2#: Battery

Battery Type	Li-ion
Manufacturer	ATL
Model Number	UBATIA321AFN2
Capacity	(typ.)5000 mAh / (min.) 4860mAh
Nominal Voltage	3.87V

AE (Auxiliary Equipment) 3#: ADAPTER

Manufacturer	ELECOM.
Model Number	NY-PW0F3-05002400
Input Voltage	100-240VAC,50Hz/60Hz 0.4A
Output Voltage	5VDC,2.4A

Note1: As the information described, the relevant tests have been performed in order to verify in which mode would have the worst features, so all the tests shown in this test report are performed when the EUT1 exercised by the Wireless Charging AE1, the Battery AE2 and the ADAPTER AE3.

1.7.4 Operation Mode

Test has performed with the Charging base combined with the EUT under its battery power more than 90% energy. So all the test performed when the EUT working with battery power is more than 90%.

2. Test information

2.1 Summary of the test results

No.	Test case	Verdict
1	Conducted emissions	Pass
2	Radiated emissions	Pass
3	20dB Bandwidth and 99% Bandwidth	Pass

Approved By: Mr. Liu Wei Director of the test department 	Checked By Mr. Guo Yu Vice director of the test department 
Tested by: Mr. Wen Jianlong Test engineer 	Issued date: 2024.9.13

2.2 Test result

2.2.1 Conducted Emissions-FCC Part15.207

Ambient condition:

Temperature	Relative humidity	Pressure
22.0°C	39.4%	100.8kPa

Test Setup with charger:

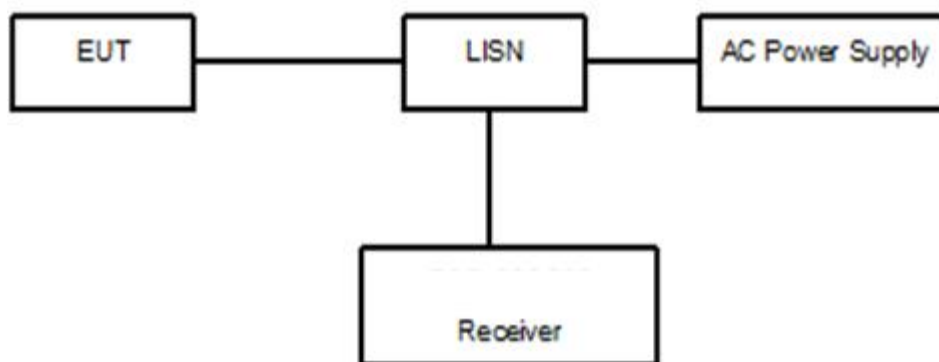

Figure 1

Test Procedure:

The EUT is placed on a non-metallic table 0.8m above the horizontal metal reference ground plane. The EUT is connected with LISN via the charger and Charging base. The LISN is connected to the reference ground. Open the following functions of EUT: Alarm clock.

The test set-up and the test methods are performed according to ANSI C63.10:2013. Then start the test software EMC32. Sweep the whole frequency band through the range from 150 KHz to 30 MHz with RBW 9kHz, VBW 30kHz. The measurement should be done for both L line and N line. During pre-test, the receiver uses both peak detector and average detector. And the final test, the receiver uses both average detector and Quasi-peak detector.

A "reference path loss" Corr.(dB) is established and the $L_{cable}+ATT+VDF$ is the attenuation of "reference path loss", and including the cable loss, the attenuation of the attenuator, the voltage division factor of AMN.

The measurement results are obtained as described below:

$$P_{result}=P_{mea}+Corr.(dB)$$

Sample calculation: $(28.12\text{dB}\mu\text{V}) = (-1.48\text{dB}\mu\text{V}) + (29.6\text{ dB})$, the corresponding frequency is 0.17132MHz.

Limit:

Frequency of Emission(MHz)	Limits(dB μ V)	
	Quasi-peak	Average
0.15~0.5	66 to 56*	56 to 46*
0.5~5	56	46
5~30	60	50

Note: * Decreases with the logarithm of the frequency

Test result:

Noise Level of the Measuring Instrument

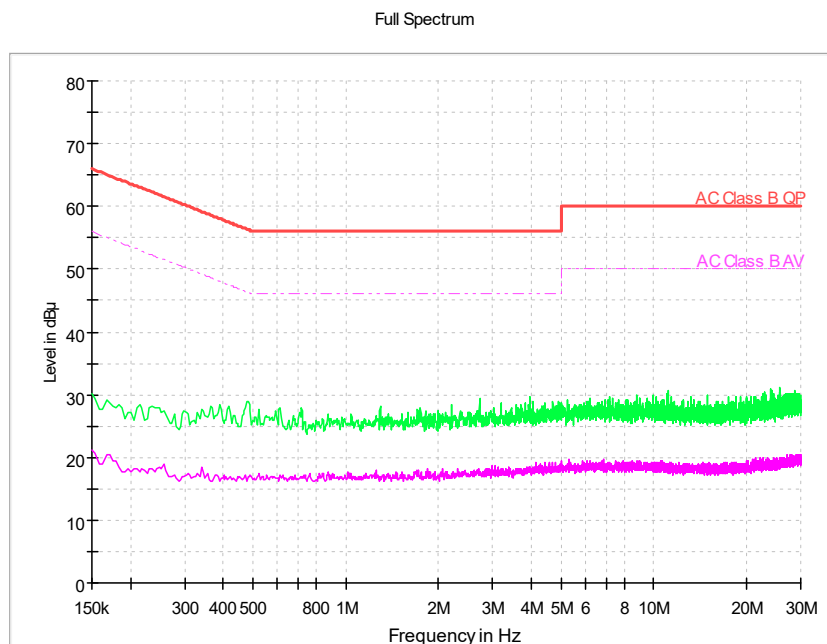

Pic1. Conducted emission L and N Line

EUT1 + AE#1: Wireless Charging +AE #2: Battery +AE #3: ADAPTER:

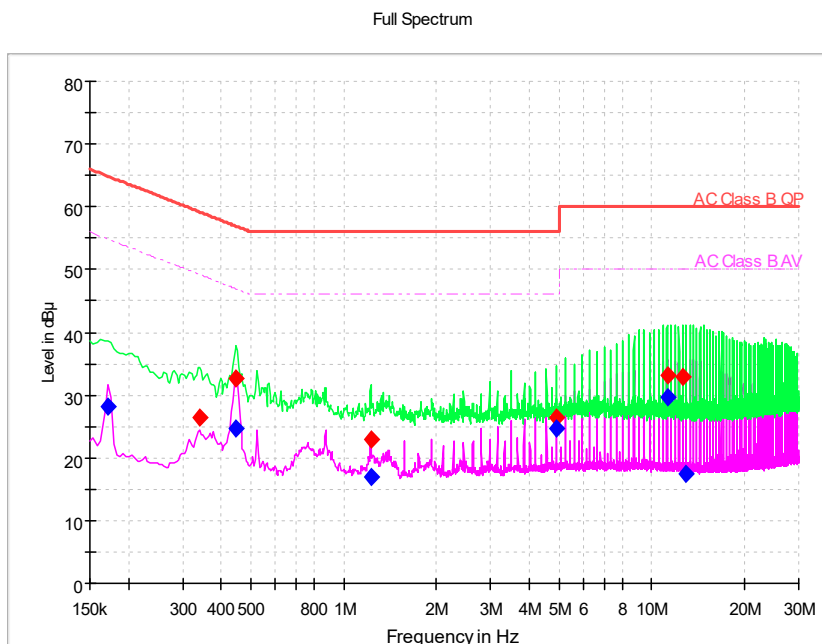

Pic2. Conducted emission L&N Line Voltage: 120VAC

Frequency (MHz)	QuasiPeak (dBµV)	Average (dBµV)	Limit (dBµV)	Margin (dB)	Line	Corr (dB)	P _{mea} QuasiPeak (dBµV)	P _{mea} Average (dBµV)
0.17132	---	28.12	54.90	26.78	N	29.60	---	-1.48
0.34189	26.35	---	59.16	32.81	N	29.60	-3.25	---
0.44424	---	24.67	46.98	22.31	L1	29.60	---	-4.93
0.44850	32.63	---	56.90	24.27	N	29.60	3.03	---
1.22460	---	16.98	46.00	29.02	N	29.60	---	-12.62
1.22460	22.97	---	56.00	33.03	N	29.60	-6.63	---
4.90468	---	24.63	46.00	21.37	L1	29.70	---	-5.07
4.90468	26.54	---	56.00	29.46	L1	29.70	-3.16	---
11.21156	---	29.72	50.00	20.28	N	29.90	---	-0.18
11.21156	33.27	---	60.00	26.73	N	29.90	3.37	---
12.61024	33.01	---	60.00	26.99	L1	29.90	3.11	---
12.96418	---	17.43	50.00	32.57	N	29.90	---	-12.47

EUT1 + AE#1: Wireless Charging +AE #2: Battery +AE #3: ADAPTER:

Full Spectrum

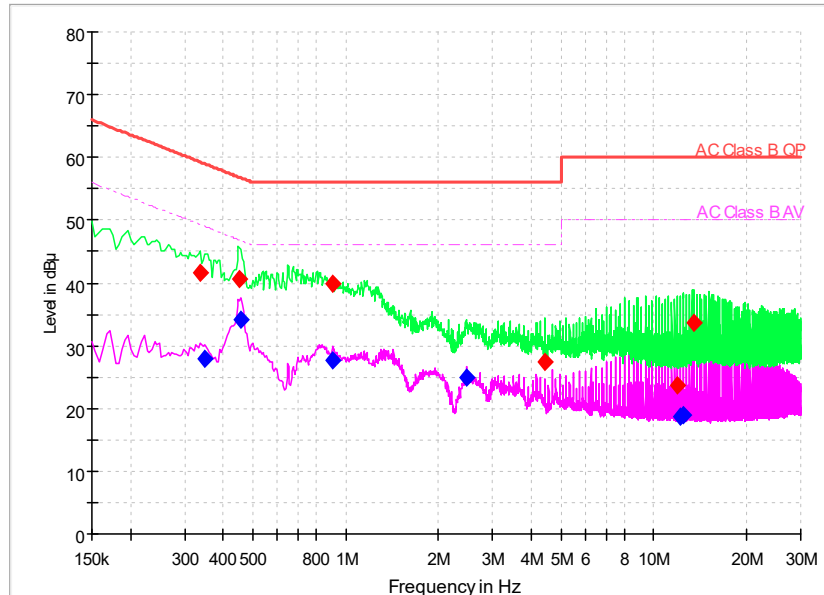

Pic3. Conducted emission L&N Line Voltage: 240VAC

Frequency (MHz)	QuasiPeak (dBμV)	Average (dBμV)	Limit (dBμV)	Margin (dB)	Line	Corr. (dB)	P _{mea} QuasiPeak (dBμV)	P _{mea} Average (dBμV)
0.33763	41.53	---	59.26	17.73	N	29.60	11.93	---
0.35042	---	27.96	48.95	20.99	N	29.60	---	-1.64
0.45276	40.52	---	56.82	16.30	L1	29.60	10.92	---
0.45703	---	34.12	46.75	12.63	N	29.60	---	4.52
0.90478	39.86	---	56.00	16.14	N	29.60	10.26	---
0.90904	---	27.76	46.00	18.24	L1	29.60	---	-1.84
2.47404	---	24.88	46.00	21.12	N	29.60	---	-4.72
4.42708	27.38	---	56.00	28.62	L1	29.70	-2.32	---
11.97913	23.66	---	60.00	36.34	N	29.90	-6.24	---
12.23499	---	18.72	50.00	31.28	L1	29.90	---	-11.18
12.49511	---	18.99	50.00	31.01	L1	29.90	---	-10.91
13.54412	33.62	---	60.00	26.38	L1	29.90	3.72	---

2.2.2 Radiated Emissions-FCC Part15.209

Ambient condition:

Temperature	Relative humidity	Pressure
22.6°C	38.8%	100.8kPa

Test Setup:

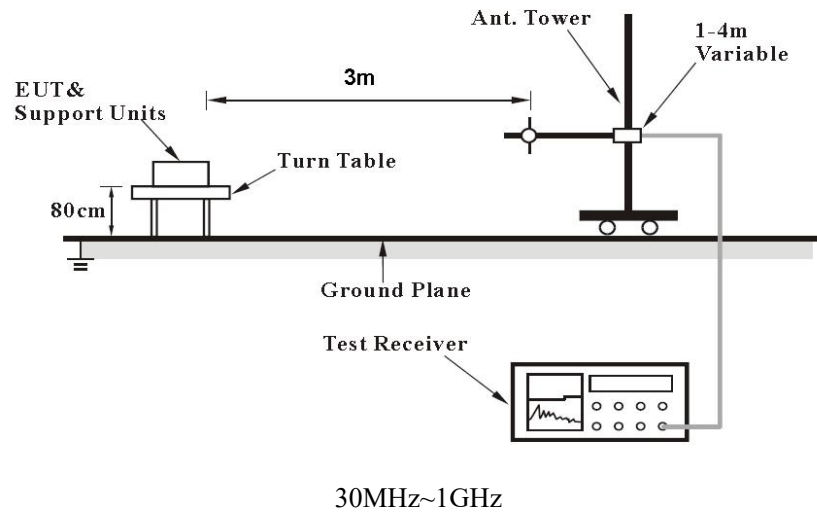
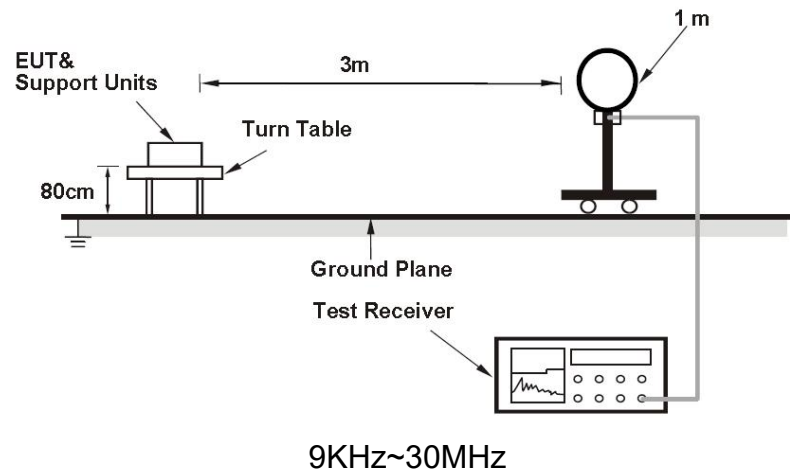

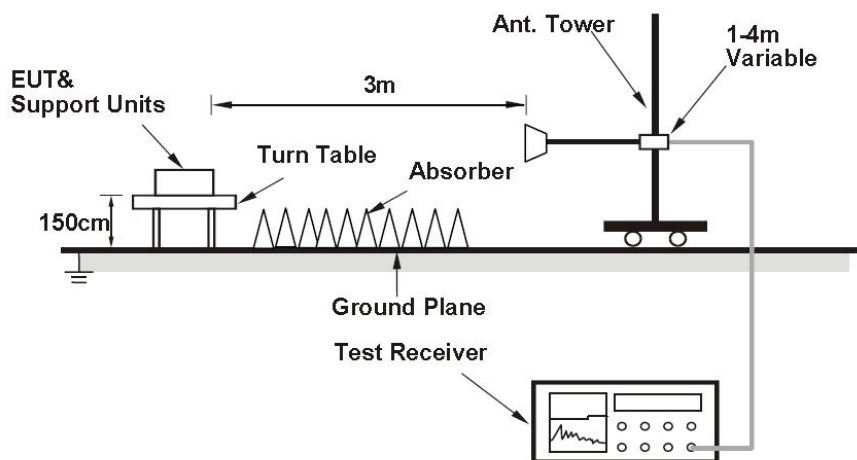

Above 1GHz

Figure 2

Test Procedure:

The EUT should be placed on a non-metallic table 80cm above the ground plane. The receive antennas shall be moved from 1 to 4 meters above 30MHz. The distance between EUT and receive antenna should be 3 meters.

The EUT should work in charging mode. The test set-up and the test methods are performed according to ANSI C63.10:2013..

Then start the test software EMC32. Sweep the whole frequency band through the range from 9KHz to 30MHz, using receive log period antenna HFH2-Z2. The lowest height of the magnetic antenna shall be 1 m above the ground. Measurement is made aligning the loop antenna along the site axis, orthogonal to the axis (x,y,z), when perpendicular to the ground plane. Sweep the whole frequency band through the range from 30MHz to 1GHz, using receive log period antenna VULB 9163.

During the test, the height of receive antenna shall be moved from 1 to 4 meters, and the antenna shall be performed under horizontal and vertical polarization. The turn table shall be rotated from 0 to 360 degrees for detecting the maximum of radiated spurious signal level. The measurements shall be repeated with orthogonal polarization of the test antenna. The EUT is laid in two modes as follow: 1. put the EUT in horizontal direction; 2. put the EUT in vertical direction.

The data of cable loss and antenna factor have been calibrated in full testing frequency range before the testing. All test results are performed with max hold at the horizontal and vertical polarity.

RBW=120kHz, VBW=300kHz, when the test frequency: 30MHz<f<1GHz

RBW=1MHz, VBW=3MHz, when the test frequency: f>1GHz

A "reference path loss" is established and the A_{Rpl} is the attenuation of "reference path loss", and including the gain of receive antenna, the gain of the preamplifier, the cable loss.

The measurement results are obtained as described below:

$$\text{Result} = P_{\text{mea}} + A_{\text{Rpl}}$$

Sample calculation: $(9.84 \text{ dB}\mu\text{V/m}) = (30.16 \text{ dB}\mu\text{V}) + (-13.3\text{dB/m})$, the corresponding frequency is 34.455MHz.

Limit:

Frequency (MHz)	Field strength (uV/m)	Measurement distance (meters)
0.009-0.490	2400/F(kHz)	300
0.490-1.705	24000/F(kHz)	30
1.705-30.0	30	30
30-88	100	3
88-216	150	3
216-960	200	3
Above 960	500	3

The Detector and RBW/VBW Setting:

Frequency(MHz)	Detector	RBW	VBW
0.009-0.15	Average	200Hz	1KHz
0.15-0.49	Average	9KHz	30KHz
0.49-30	Quasi-peak	9KHz	30KHz
30-1000	Quasi-peak	100KHz	300KHz
1000-6000	Peak and Average	1MHz	3MHz

30-1000MHz

Frequency (MHz)	Result (dBuV/m)	ARpl (dB/m)	Margin (dB)	Polarity	Limit (dBuV/m)	Pmea (dBuV)
31.455	9.84	-13.3	23.14	Vertical	40.0	30.16
84.8535	2.25	-23.3	25.55	Vertical	40.0	37.75
129.037	21.85	-22.0	43.85	Vertical	43.5	21.65
294.471	15.88	-18.6	34.48	Vertical	46.0	30.12
536.68	11.10	-11.4	22.50	Vertical	46.0	34.90
926.135	16.91	-4.4	21.31	Vertical	46.0	29.09

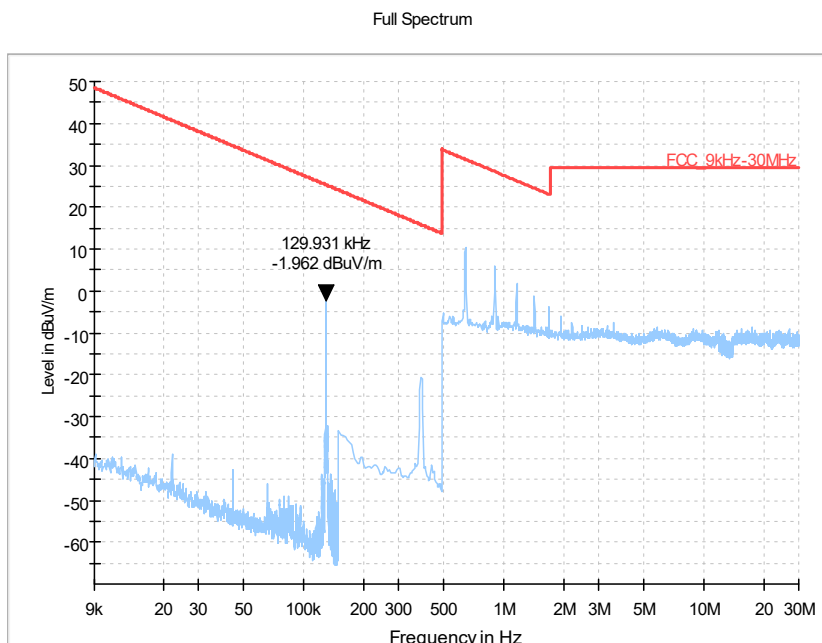

Pic4. Radiated emission(9KHz – 30MHz)

Note: Loop antenna at 3M, the test result has extrapolated to the specified distance which standard required.

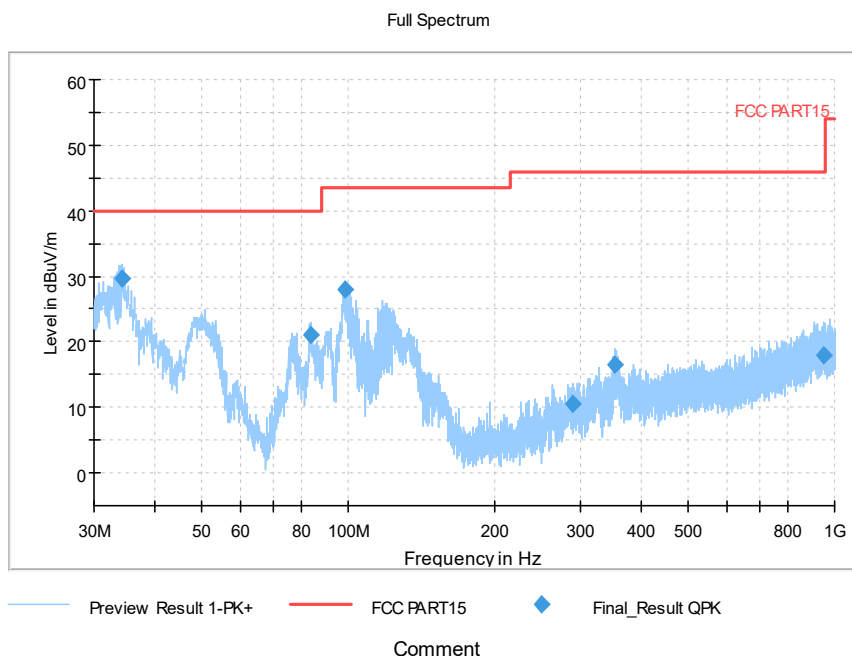

Pic5. Radiated emission(30MHz – 1GHz)

Note: The test data in the graph includes two polarizations: horizontal and vertical

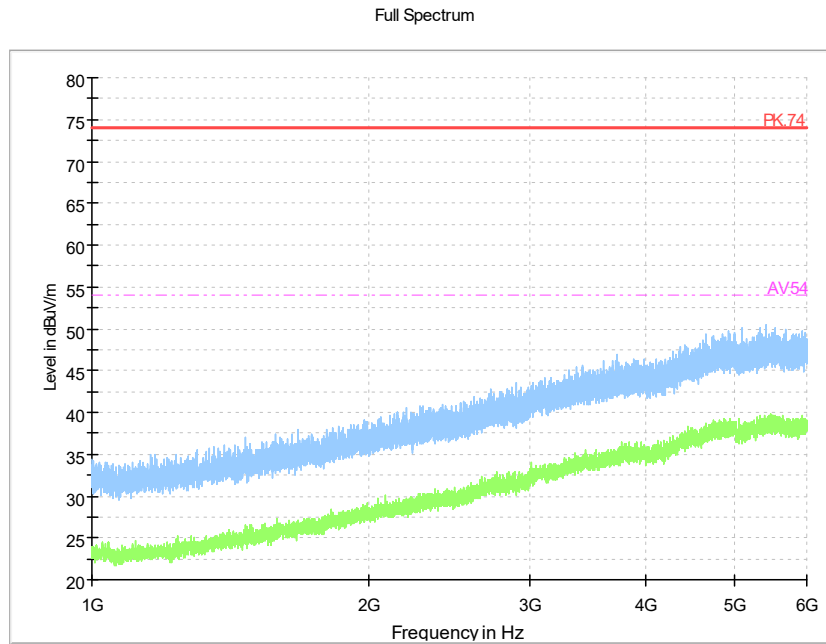

Pic6. Radiated emission (1GHz – 6GHz)

Note: The test data in the graph includes two polarizations: horizontal and vertical

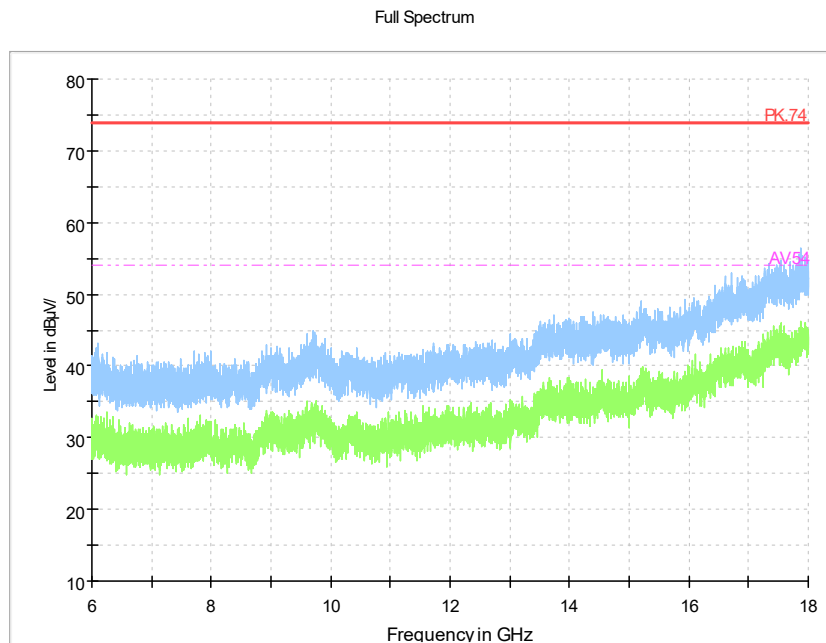

Pic7. Radiated emission (6GHz – 18GHz)

Note: The test data in the graph includes two polarizations: horizontal and vertical

Full Spectrum

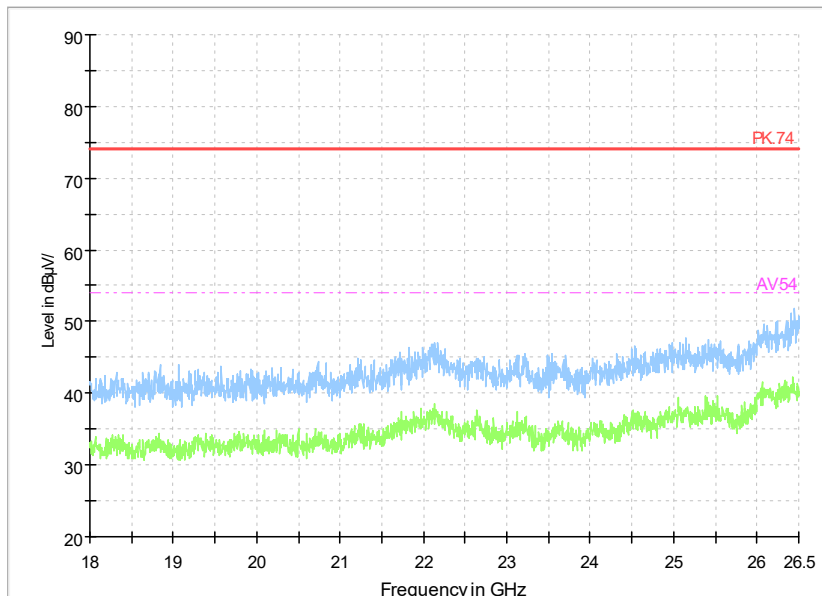

Pic8. Radiated emission (18GHz – 26GHz)

Note: The test data in the graph includes two polarizations: horizontal and vertical

2.2.3 20dB Bandwidth and 99% Bandwidth

Test Procedure:

The bandwidth is measured at an amplitude level reduced from the reference level by a specified ratio. The reference level is the level of the highest amplitude signal observed from the transmitter at either the fundamental frequency or first-order modulation in all typical modes of operation, including the unmodulated carrier, even if at typical . Once the reference level is established, the equipment is conditioned with typical modulating signals to produce worst –case (i.e.,the widest) bandwidth. In order to measure the modulated signal properly, a resolution bandwidth that is small compared to the bandwidth required by the procuring or regulatory agency shall be used on the measuring instrument. However, the 6 dB resolution bandwidth of the measuring instrument shall be set to a value greater than 5% of the bandwidth requirements.

Limit:

Within the specified band

Test result:
20 dB bandwidth is:

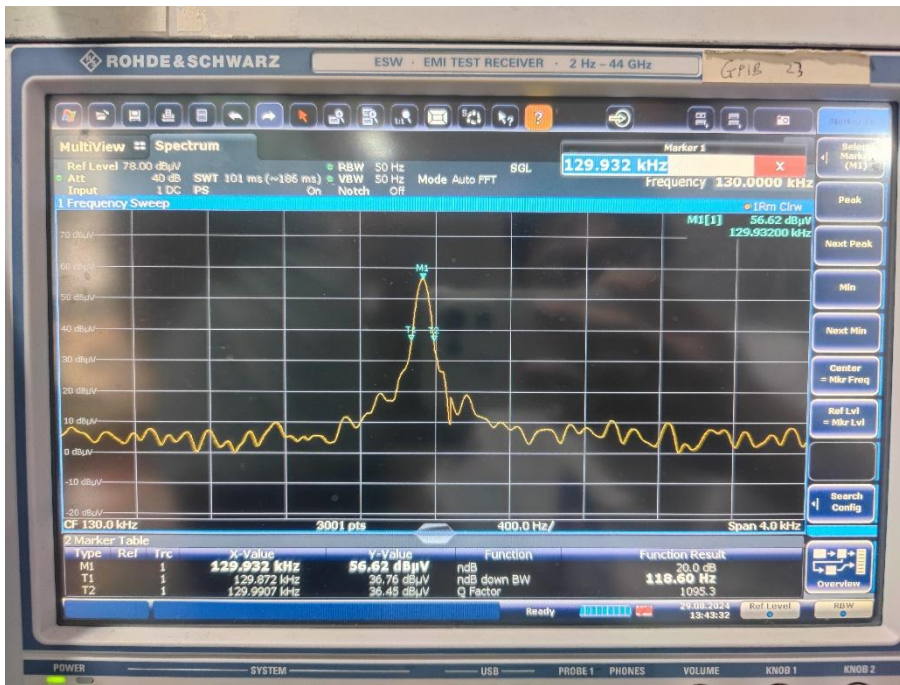

Bandwidth: 118.60 Hz

99% Bandwidth:

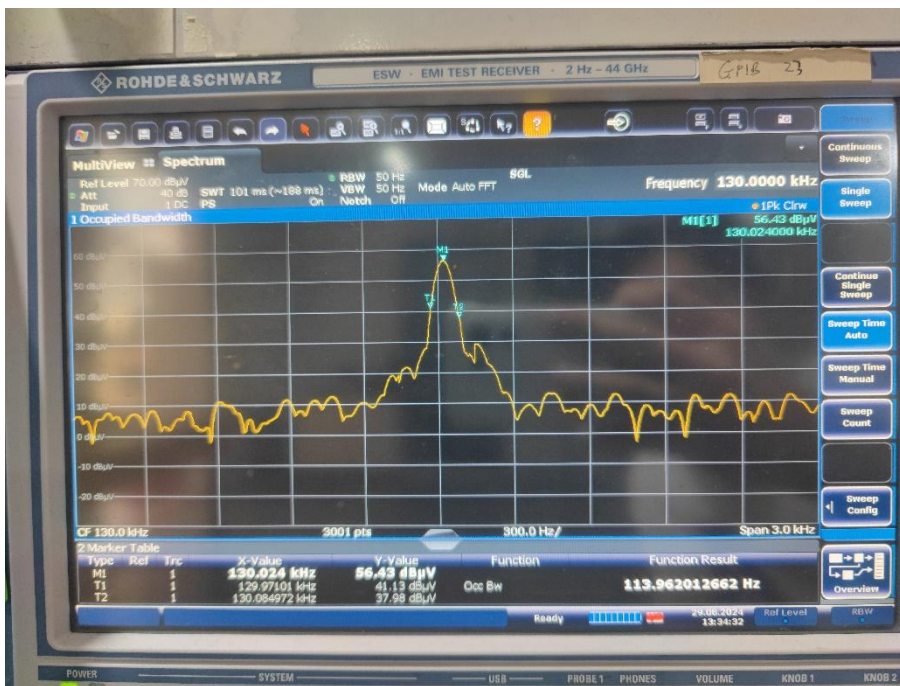

Bandwidth: 113.96Hz

2.3. List of test equipments

No.	Name/Model	Manufacturer	S/N	Calibration Due Date	Calibration Date
1	23.18m×16.88m×9.60mS emi-AnechoicChamber	FRANKONIA	-----	2028.09.04	2023.09.05
2	ESW EMI test receiver	R&S	101574	2025.03.05	2024.03.06
3	ESR3 EMI test receiver	R&S	102361	2025.03.05	2024.03.06
4	9.080m×5.255m×3.525m Shielding room	FRANKONIA	-----	2027.03.24	2022.03.25
5	VULB 9163 Ultra log test antenna	schwarzbeck	727	2025.05.27	2023.05.28
6	HF 907 Double-Ridged Waveguide Horn Antenna	R&S	100512	2025.07.19	2023.07.20
7	SAS-574 Horn Antenna	schwarzbeck	535	2025.05.11	2023.05.12
8	ENV216 AMN	R&S	101881	2025.06.20	2024.06.21
9	EMC32EMI test software	R&S	V10	-----	-----
10	HFH2-Z2 LOOP Antenna	R&S	100068	2025.08.19	2024.08.20