



FCC RADIO TEST REPORT

FCC ID : APYHRO00327
Equipment : Smart phone
Brand Name : SHARP
Model Name : APYHRO00327
Applicant : SHARP CORPORATION
1 Takumi-Cho, Sakai-Ku, Sakai-Shi,
Osaka 590-8522, Japan
Manufacturer : SHARP CORPORATION
1 Takumi-Cho, Sakai-Ku, Sakai-Shi,
Osaka 590-8522, Japan
Standard : FCC 47 CFR Part 2, 22(H), 24(E), 27

The product was received on Mar. 14, 2023 and testing was performed from Apr. 15, 2023 to Apr. 27, 2023. We, Sporton International Inc. EMC & Wireless Communications Laboratory, would like to declare that the tested sample has been evaluated in accordance with the test procedures given in ANSI / TIA-603-E and has been in compliance with the applicable technical standards.

The test results in this report apply exclusively to the tested model / sample. Without written approval from Sporton International Inc. EMC & Wireless Communications Laboratory, the test report shall not be reproduced except in full.

Louis Wu

Approved by: Louis Wu

Sporton International Inc. EMC & Wireless Communications Laboratory

No. 52, Huaya 1st Rd., Guishan Dist., Taoyuan City 333, Taiwan (R.O.C.)



Table of Contents

History of this test report..... 3

Summary of Test Result..... 4

1 General Description 6

 1.1 Product Feature of Equipment Under Test..... 6

 1.2 Modification of EUT 7

 1.3 Testing Location 7

 1.4 Applicable Standards..... 8

2 Test Configuration of Equipment Under Test 9

 2.1 Test Mode..... 9

 2.2 Connection Diagram of Test System..... 11

 2.3 Support Unit used in test configuration and system 11

 2.4 Measurement Results Explanation Example..... 11

 2.5 Frequency List of Low/Middle/High Channels 12

3 Conducted Test Items..... 14

 3.1 Measuring Instruments 14

 3.2 Conducted Output Power and ERP/EIRP 15

 3.3 Peak-to-Average Ratio 16

 3.4 Occupied Bandwidth..... 17

 3.5 Conducted Band Edge 18

 3.6 Conducted Spurious Emission 20

 3.7 Frequency Stability 21

4 Radiated Test Items 22

 4.1 Measuring Instruments 22

 4.2 Radiated Spurious Emission Measurement 24

5 List of Measuring Equipment..... 25

6 Measurement Uncertainty 26

Appendix A. Test Results of Conducted Test

Appendix B. Test Results of Radiated Test

Appendix C. Test Setup Photographs



History of this test report

Report No.	Version	Description	Issue Date
FG322209B	01	Initial issue of report	May 11, 2023



Summary of Test Result

Report Clause	Ref Std. Clause	Test Items	Result (PASS/FAIL)	Remark
3.2	§2.1046	Conducted Output Power	Reporting only	-
	§22.913 (a)(5)	Effective Radiated Power (Band 5)	Pass	
	§27.50 (c)(10)	Effective Radiated Power (Band 12) (Band 17)		
	§24.232 (c) §27.50 (h)(2)	Equivalent Isotropic Radiated Power (Band 2) (Band 38)		
3.3	§24.232 (d)	Peak-to-Average Ratio	Pass	-
3.4	§2.1049	Occupied Bandwidth	Reporting only	-
3.5	§2.1051 §22.917 (a) §24.238 (a) §27.53 (g)	Conducted Band Edge Measurement (Band 2) (Band 5) (Band 12) (Band 17)	Pass	-
	§2.1051 §27.53 (m)(4)	Conducted Band Edge Measurement (Band 38)		
3.6	§2.1051 §22.917 (a) §24.238 (a) §27.53 (g)	Conducted Spurious Emission (Band 2) (Band 5) (Band 12) (Band 17)	Pass	-
	§2.1051 §27.53 (m)(4)	Conducted Spurious Emission (Band 38)		
3.7	§2.1055 §22.355 §24.235 §27.54	Frequency Stability Temperature & Voltage	Pass	-



Report Clause	Ref Std. Clause	Test Items	Result (PASS/FAIL)	Remark
4.2	§2.1053 §22.917 (a) §24.238 (a) §27.53 (g)	Radiated Spurious Emission (Band 2) (Band 5) (Band 12) (Band 17)	Pass	21.97 dB under the limit at 10284.000 MHz
	§2.1051 §27.53 (m)(4)	Radiated Spurious Emission (Band 38)		

Conformity Assessment Condition:

1. The test results (PASS/FAIL) with all measurement uncertainty excluded are presented against the regulation limits or in accordance with the requirements stipulated by the applicant/manufacture who shall bear all the risks of non-compliance that may potentially occur if measurement uncertainty is taken into account.
2. The measurement uncertainty please refer to each test result in the section "Measurement Uncertainty".

Disclaimer:

The product specifications of the EUT presented in the test report that may affect the test assessments are declared by the manufacturer who shall take full responsibility for the authenticity.

Reviewed by: Keven Cheng

Report Producer: Michelle Chen



1 General Description

1.1 Product Feature of Equipment Under Test

Product Feature	
General Specs GSM/WCDMA/LTE, Bluetooth, Wi-Fi 2.4GHz 802.11b/g/n, Wi-Fi 5GHz 802.11a/n/ac, FM Receiver, NFC, and GNSS.	
Antenna Type WWAN: <Ant. 0>: Monopole Antenna <Ant. 1>: PIFA Antenna <Ant. 2>: Monopole Antenna WLAN: Loop Antenna Bluetooth: Loop Antenna GPS / Glonass / BDS / Galileo: PIFA Antenna NFC: Loop Antenna FM: Using earphone as antenna	
Antenna Gain	Band 2: -0.80 dBi Band 5: -4.60 dBi Band 12: -3.09 dBi Band 17: -3.09 dBi Band 38: -3.49 dBi

Remark: The EUT's information above is declared by manufacturer. Please refer to Disclaimer in report summary.

SKU List				
Item	Main		2nd Source	
	Main Sample		Sample 2	
	Vendor	Model Number	Vendor	Model Number
Battery	SCUD	BPSX1000010	UTL	BPSX300001S
Main PCB	Wuzhu	SB0SX31BW0C	ZDT	SB0SX31BK0C
CPU	MTK	SA06833V010 (MT6833V_NZA)	MTK	SA06833V010 (MT6833V_NZA)
G- sensor	Bosch	SA0MI320020(BMI320)	TDK	SA042670020(ICM-42670-N)
rear housing	DY	MESX361010A	LF	MESX361011A
FPC_USB	SUNFLEX	MESX114012A	PBH	MESX314004A
FPC_AJ	SUNFLEX	MESX114013A	PBH	MESX314003A
FPC_Main	SUNFLEX	MESX314002A	PBH	MESX314012A
FPC_SPK	AKM	MESX114005A	PBH	MESX314005A
FPC_Side_Key	SUNFLEX	MESX314001A	PBH	MESX314011A
Memory	SAMSUNG	KM5P9001DM-B424	SAMSUNG	KM5P9001DM-B424



SKU List				
Item	2nd Source			
	Sample 3		Sample 4	
	Vendor	Model Number	Vendor	Model Number
Battery	SCUD	BPSX1000010	SCUD	BPSX1000010
Main PCB	Wuzhu	SB0SX31BW0C	Wuzhu	SB0SX31BW0C
CPU	MTK	SA06833V011 (MT6833V_ZA)	MTK	SA06833V010 (MT6833V_NZA)
G- sensor	Bosch	SA0MI320020(BMI320)	Bosch	SA0MI320020(BMI320)
rear housing	DY	MESX361030A	DY	MESX361010A
FPC_USB	PBH	MESX314004A	PBH	MESX314004A
FPC_AJ	PBH	MESX314003A	PBH	MESX314003A
FPC_Main	SUNFLEX	MESX314002A	SUNFLEX	MESX314002A
FPC_SPK	AKM	MESX114005A	AKM	MESX114005A
FPC_Side_Key	SUNFLEX	MESX314001A	SUNFLEX	MESX314001A
Memory	SAMSUNG	KM5P9001DM-B424	Hynix	H9QG9G5AN6X154

1.2 Modification of EUT

No modifications made to the EUT during the testing.

1.3 Testing Location

Test Site	Sporton International Inc. EMC & Wireless Communications Laboratory
Test Site Location	No.52, Huaya 1st Rd., Guishan Dist., Taoyuan City 333, Taiwan (R.O.C.) TEL: +886-3-327-3456 FAX: +886-3-328-4978
Test Site No.	Sporton Site No. TH03-HY
Test Engineer	Cotty Hsu
Temperature (°C)	22.1~22.8
Relative Humidity (%)	53~55



Test Site	Sporton International Inc. Wensan Laboratory
Test Site Location	No.58, Aly. 75, Ln. 564, Wenhua 3rd, Rd., Guishan Dist., Taoyuan City 333010, Taiwan (R.O.C.) TEL: +886-3-327-0868 FAX: +886-3-327-0855
Test Site No.	Sporton Site No. 03CH23-HY (TAF Code: 3786)
Test Engineer	Leo Li
Temperature (°C)	18~21
Relative Humidity (%)	68~70
Remark	The Radiated Test Items subcontracted to Sporton International Inc. Wensan Laboratory.

Note: The test site complies with ANSI C63.4 2014 requirement.

FCC Designation No.: TW1190 and TW3786

1.4 Applicable Standards

According to the specifications of the manufacturer, the EUT must comply with the requirements of the following standards:

- ♦ ANSI C63.26-2015
- ♦ ANSI / TIA-603-E
- ♦ FCC 47 CFR Part 2, 22(H), 24(E), 27
- ♦ FCC KDB 971168 D01 Power Meas. License Digital Systems v03r01
- ♦ FCC KDB 412172 D01 Determining ERP and EIRP v01r01
- ♦ FCC KDB 414788 D01 Radiated Test Site v01r01.

Remark:

1. All the test items were validated and recorded in accordance with the standards without any modification during the testing.
2. This EUT has also been tested and complied with the requirements of FCC Part 15, Subpart B, recorded in a separate test report.
3. The TAF code is not including all the FCC KDB listed without accreditation.



2 Test Configuration of Equipment Under Test

2.1 Test Mode

Antenna port conducted and radiated test items listed below are performed according to KDB 971168 D01 Power Meas. License Digital Systems v03r01 with maximum output power.

For radiated measurement, the measured emission level of the EUT was maximized by rotating the EUT on a turntable, adjusting the orientation of the EUT and EUT antenna in three orthogonal axis (X: flat, Y: portrait, Z: landscape), and adjusting the measurement antenna orientation, following C63.26 exploratory test procedures and only the worst case emissions were reported in this report.

Test Items	Band	Bandwidth (MHz)						Modulation			RB #			Test Channel		
		1.4	3	5	10	15	20	QPSK	16QAM	64QAM	1	Half	Full	L	M	H
Max. Output Power	2	v	v	v	v	v	v	v	v	v	v	v	v	v	v	v
	5	v	v	v	v	-	-	v	v	v	v	v	v	v	v	v
	12	v	v	v	v	-	-	v	v	v	v	v	v	v	v	v
	17	-	-	v	v	-	-	v	v	v	v	v	v	v	v	v
	38	-	-	v	v	v	v	v	v	v	v	v	v	v	v	v
Peak-to-Average Ratio	2						v	v	v	v			v		v	
	5				v	-	-	v	v	v			v		v	
	12				v	-	-	v	v	v			v		v	
	17	Covered by Band 12														
	38	-	-				v	v	v	v	v		v		v	
26dB and 99% Bandwidth	2	v	v	v	v	v	v	v	v	v			v		v	
	5	v	v	v	v	-	-	v	v	v			v		v	
	12	v	v	v	v	-	-	v	v	v			v		v	
	17	Covered by Band 12														
	38	-	-	v	v	v	v	v	v	v			v		v	
Conducted Band Edge	2	v	v	v	v	v	v	v	v	v	v		v	v		v
	5	v	v	v	v	-	-	v	v	v	v		v	v		v
	12	v	v	v	v	-	-	v	v	v	v		v	v		v
	17	Covered by Band 12														
	38	-	-	v	v	v	v	v	v	v	v		v	v		v



Test Items	Band	Bandwidth (MHz)						Modulation			RB #			Test Channel		
		1.4	3	5	10	15	20	QPSK	16QAM	64QAM	1	Half	Full	L	M	H
Conducted Spurious Emission	2	v	v	v	v	v	v	v	v	v	v			v	v	v
	5	v	v	v	v	-	-	v	v	v	v			v	v	v
	12	v	v	v	v	-	-	v	v	v	v			v	v	v
	17	Covered by Band 12														
	38	-	-	v	v	v	v	v	v	v	v			v	v	v
Frequency Stability	2				v			v					v		v	
	5				v	-	-	v					v		v	
	12				v	-	-	v					v		v	
	17	Covered by Band 12														
	38	-	-		v			v					v		v	
E.R.P / E.I.R.P	2	v	v	v	v	v	v	v	v	v	Max. Power					
	5	v	v	v	v	-	-	v	v	v						
	12	v	v	v	v	-	-	v	v	v						
	17	-	-	v	v	-	-	v	v	v						
	38	-	-	v	v	v	v	v	v	v						
Radiated Spurious Emission	2	Worst Case											v	v	v	
	5	Worst Case											v	v	v	
	12	Worst Case											v	v	v	
	38	Worst Case											v	v	v	
Remark	<p>1. The mark "v " means that this configuration is chosen for testing</p> <p>2. The mark "- " means that this bandwidth is not supported.</p> <p>3. The device is investigated from 30MHz to 10 times of fundamental signal for radiated spurious emission test under different RB size/offset and modulations in exploratory test. Subsequently, only the worst case emissions are reported.</p> <p>4. All the radiated test cases were performed with Adapter 2 and Battery 1.</p> <p>5. Wider operating range bandwidth covers narrower one when the power is higher or the same.</p> <p>6. One representative bandwidth is selected to perform PAR and frequency stability.</p>															

2.2 Connection Diagram of Test System

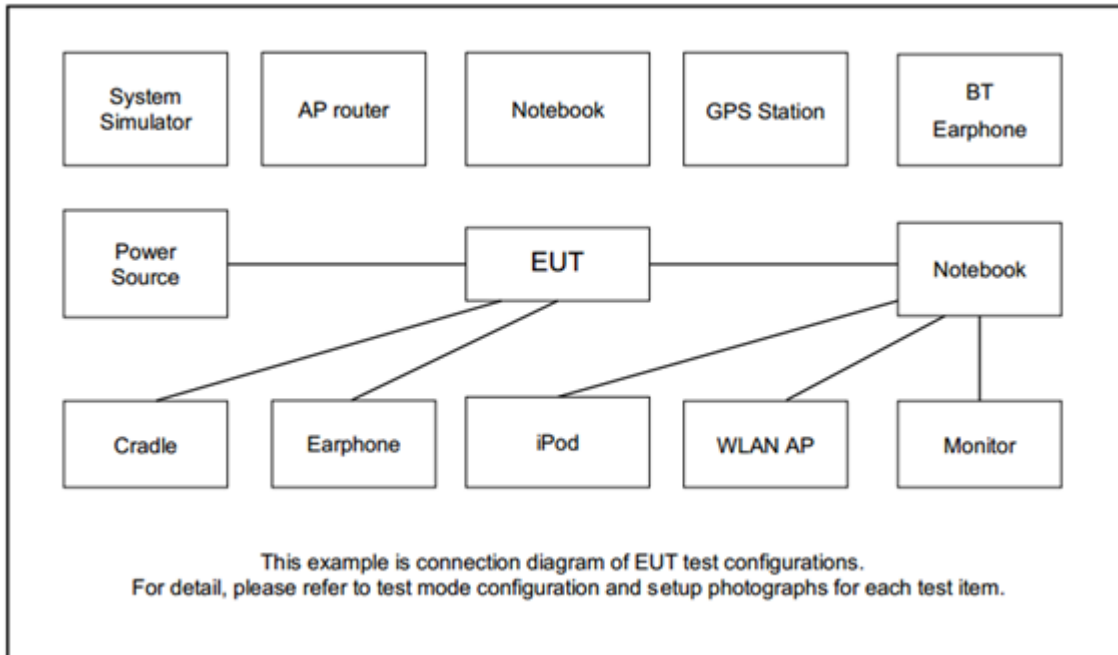

2.3 Support Unit used in test configuration and system

Item	Equipment	Brand Name	Model No.	FCC ID	Data Cable	Power Cord
1.	System Simulator	Anritsu	MT8820C	N/A	N/A	Unshielded, 1.8 m

2.4 Measurement Results Explanation Example

For all conducted test items:

The offset level is set in the spectrum analyzer to compensate the RF cable loss and attenuator factor between EUT conducted output port and spectrum analyzer. With the offset compensation, the spectrum analyzer reading level is exactly the EUT RF output level.

The spectrum analyzer offset is derived from RF cable loss and attenuator factor.

Offset = RF cable loss + attenuator factor.

Following shows an offset computation example with cable loss 4.2 dB and 10dB attenuator.

Example :

Offset(dB) = RF cable loss(dB) + attenuator factor(dB).

$$= 4.2 + 10 = 14.2 \text{ (dB)}$$



2.5 Frequency List of Low/Middle/High Channels

LTE Band 2 Channel and Frequency List				
BW [MHz]	Channel/Frequency(MHz)	Lowest	Middle	Highest
20	Channel	18700	18900	19100
	Frequency	1860	1880	1900
15	Channel	18675	18900	19125
	Frequency	1857.5	1880	1902.5
10	Channel	18650	18900	19150
	Frequency	1855	1880	1905
5	Channel	18625	18900	19175
	Frequency	1852.5	1880	1907.5
3	Channel	18615	18900	19185
	Frequency	1851.5	1880	1908.5
1.4	Channel	18607	18900	19193
	Frequency	1850.7	1880	1909.3

LTE Band 5 Channel and Frequency List				
BW [MHz]	Channel/Frequency(MHz)	Lowest	Middle	Highest
10	Channel	20450	20525	20600
	Frequency	829	836.5	844
5	Channel	20425	20525	20625
	Frequency	826.5	836.5	846.5
3	Channel	20415	20525	20635
	Frequency	825.5	836.5	847.5
1.4	Channel	20407	20525	20643
	Frequency	824.7	836.5	848.3

LTE Band 12 Channel and Frequency List				
BW [MHz]	Channel/Frequency(MHz)	Lowest	Middle	Highest
10	Channel	23060	23095	23130
	Frequency	704	707.5	711
5	Channel	23035	23095	23155
	Frequency	701.5	707.5	713.5
3	Channel	23025	23095	23165
	Frequency	700.5	707.5	714.5
1.4	Channel	23017	23095	23173
	Frequency	699.7	707.5	715.3



LTE Band 17 Channel and Frequency List				
BW [MHz]	Channel/Frequency(MHz)	Lowest	Middle	Highest
10	Channel	23780	23790	23800
	Frequency	709	710	711
5	Channel	23755	23790	23825
	Frequency	706.5	710	713.5

LTE Band 38 Channel and Frequency List				
BW [MHz]	Channel/Frequency(MHz)	Lowest	Middle	Highest
20	Channel	37850	38000	38150
	Frequency	2580.0	2595.0	2610.0
15	Channel	37825	38000	38175
	Frequency	2577.5	2595.0	2612.5
10	Channel	37800	38000	38200
	Frequency	2575.0	2595.0	2615.0
5	Channel	37775	38000	38225
	Frequency	2572.5	2595.0	2617.5

3 Conducted Test Items

3.1 Measuring Instruments

See list of measuring instruments of this test report.

3.1.1 Test Setup

3.1.2 Conducted Output Power

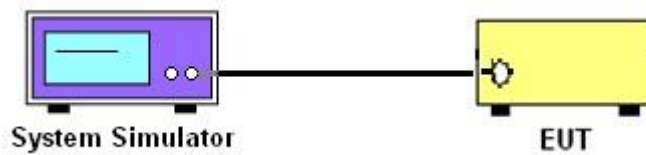

3.1.3 Peak-to-Average Ratio, Occupied Bandwidth ,Conducted Band-Edge and Conducted Spurious Emission

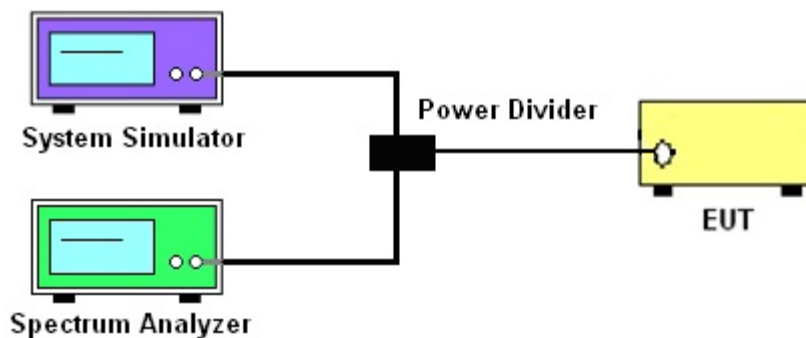

3.1.4 Frequency Stability

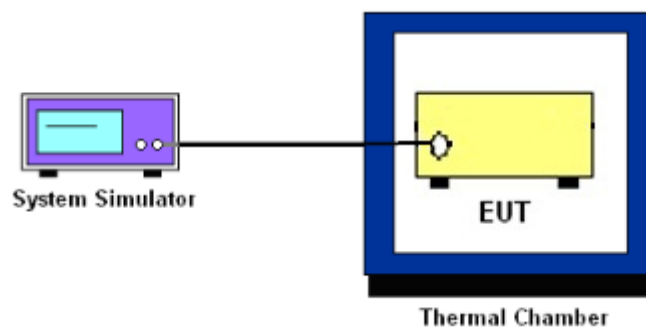

3.1.5 Test Result of Conducted Test

Please refer to Appendix A.



3.2 Conducted Output Power and ERP/EIRP

3.2.1 Description of the Conducted Output Power Measurement and ERP/EIRP Measurement

A system simulator was used to establish communication with the EUT. Its parameters were set to force the EUT transmitting at maximum output power. The measured power in the radio frequency on the transmitter output terminals shall be reported.

The ERP of mobile transmitters must not exceed 7 Watts for LTE Band 5

The ERP of mobile transmitters must not exceed 3 Watts for LTE Band 12 and Band 17

The EIRP of mobile transmitters must not exceed 2 Watts for LTE Band 2 and Band 38

According to KDB 412172 D01 Power Approach,

$EIRP = P_T + G_T - L_C$, $ERP = EIRP - 2.15$, where

P_T = transmitter output power in dBm

G_T = gain of the transmitting antenna in dBi

L_C = signal attenuation in the connecting cable between the transmitter and antenna in dB

3.2.2 Test Procedures

1. The transmitter output port was connected to the system simulator.
2. Set EUT at maximum power through the system simulator.
3. Select lowest, middle, and highest channels for each band and different modulation.
4. Measure and record the power level from the system simulator.



3.3 Peak-to-Average Ratio

3.3.1 Description of the PAR Measurement

Power Complementary Cumulative Distribution Function (CCDF) curves provide a means for characterizing the power peaks of a digitally modulated signal on a statistical basis. A CCDF curve depicts the probability of the peak signal amplitude exceeding the average power level. Most contemporary measurement instrumentation include the capability to produce CCDF curves for an input signal provided that the instrument's resolution bandwidth can be set wide enough to accommodate the entire input signal bandwidth. In measuring transmissions in this band using an average power technique, the peak-to-average ratio (PAR) of the transmission may not exceed 13 dB.

3.3.2 Test Procedures

The testing follows ANSI C63.26-2015 Section 5.2.6

1. The EUT was connected to spectrum and system simulator via a power divider.
2. Set the CCDF (Complementary Cumulative Distribution Function) option in spectrum analyzer.
3. The highest RF powers were measured and recorded the maximum PAPR level associated with a probability of 0.1 %.
4. Record the deviation as Peak to Average Ratio.



3.4 Occupied Bandwidth

3.4.1 Description of Occupied Bandwidth Measurement

The occupied bandwidth is the width of a frequency band such that, below the lower and above the upper frequency limits, the mean powers emitted are each equal to a specified percentage 0.5% of the total mean transmitted power.

The 26 dB emission bandwidth is defined as the frequency range between two points, one above and one below the carrier frequency, at which the spectral density of the emission is attenuated 26 dB below the maximum in-band spectral density of the modulated signal. Spectral density (power per unit bandwidth) is to be measured with a detector of resolution bandwidth equal to approximately 1.0% of the emission bandwidth.

3.4.2 Test Procedures

The testing follows ANSI C63.26-2015 Section 5.4.3 (26dB) and Section 5.4.4 (99OB)

1. The EUT was connected to spectrum analyzer and system simulator via a power divider.
2. The spectrum analyzer center frequency is set to the nominal EUT channel center frequency. The span range for the spectrum analyzer shall be between two and five times the anticipated OBW.
3. The nominal resolution bandwidth (RBW) shall be in the range of 1 to 5 % of the anticipated OBW, and the VBW shall be at least 3 times the RBW.
4. Set the detection mode to peak, and the trace mode to max hold.
5. Determine the reference value: Set the EUT to transmit a modulated signal. Allow the trace to stabilize. Set the spectrum analyzer marker to the highest level of the displayed trace.
(this is the reference value)
6. Determine the “-26 dB down amplitude” as equal to (Reference Value – X).
7. Place two markers, one at the lowest and the other at the highest frequency of the envelope of the spectral display such that each marker is at or slightly below the “-X dB down amplitude” determined in step 6. If a marker is below this “-X dB down amplitude” value it shall be placed as close as possible to this value. The OBW is the positive frequency difference between the two markers.
8. Use the 99 % power bandwidth function of the spectrum analyzer and report the measured bandwidth.



3.5 Conducted Band Edge

3.5.1 Description of Conducted Band Edge Measurement

22.917(a)

For operations in the 824 – 849 MHz band, the FCC limit is $43 + 10\log_{10}(P[\text{Watts}])$ dB below the transmitter power $P(\text{Watts})$ in a 100kHz bandwidth. However, in the 1MHz bands immediately outside and adjacent to the licensee's frequency block, a resolution bandwidth of at least one percent of the emission bandwidth of the fundamental emission of the transmitter may be employed.

24.238 (a)

For operations in the 1850-1910 and 1930-1990 MHz band, the FCC limit is $43 + 10\log_{10}(P[\text{Watts}])$ dB below the transmitter power $P(\text{Watts})$ in a 1MHz bandwidth. However, in the 1 MHz bands immediately outside and adjacent to the frequency block a resolution bandwidth of at least one percent of the emission bandwidth of the fundamental emission of the transmitter may be employed.

27.53 (g)

For operations in the 600MHz band and 698-746 MHz band, the FCC limit is $43 + 10\log_{10}(P[\text{Watts}])$ dB below the transmitter power $P(\text{Watts})$ in a 100 kHz bandwidth. However, in the 100 kilohertz bands immediately outside and adjacent to a licensee's frequency block, a resolution bandwidth of at least 30 kHz may be employed.

**27.53(m)(4)**

For mobile digital stations, the attenuation factor shall be not less than $40 + 10 \log (P)$ dB on all frequencies between the channel edge and 5 megahertz from the channel edge, $43 + 10 \log (P)$ dB on all frequencies between 5 megahertz and X megahertz from the channel edge, and $55 + 10 \log (P)$ dB on all frequencies more than X megahertz from the channel edge, where X is the greater of 6 megahertz or the actual emission bandwidth as defined in paragraph (m)(6) of this section. In addition, the attenuation factor shall not be less that $43 + 10 \log (P)$ dB on all frequencies between 2490.5 MHz and 2496 MHz and $55 + 10 \log (P)$ dB at or below 2490.5 MHz. Mobile Satellite Service licensees operating on frequencies below 2495 MHz may also submit a documented interference complaint against BRS licensees operating on channel BRS Channel 1 on the same terms and conditions as adjacent channel BRS or EBS licensees.

3.5.2 Test Procedures

The testing follows FCC KDB 971168 D01 v03r01 Section 6.1.

1. The EUT was connected to spectrum analyzer and system simulator via a power divider.
2. The band edges of low and high channels for the highest RF powers were measured.
3. Set RBW \geq 1% EBW in the 1MHz band immediately outside and adjacent to the band edge.
4. Beyond the 1 MHz band from the band edge, RBW=1MHz was used.
5. Set spectrum analyzer with RMS detector.
6. The RF fundamental frequency should be excluded against the limit line in the operating frequency band.
7. Checked that all the results comply with the emission limit line.

The limit line is derived from $43 + 10\log(P)$ dB below the transmitter power P(Watts)

For LTE Band 38

The other 40 dB, and 55 dB have additionally applied same calculation above.



3.6 Conducted Spurious Emission

3.6.1 Description of Conducted Spurious Emission Measurement

The power of any emission outside of the authorized operating frequency ranges must be lower than the transmitter power (P) by a factor of at least $43 + 10 \log (P)$ dB.

For LTE Band 38

The power of any emission outside of the authorized operating frequency ranges must be lower than the transmitter power (P) by a factor of at least $55 + 10 \log (P)$ dB.

It is measured by means of a calibrated spectrum analyzer and scanned from 30 MHz up to a frequency including its 10th harmonic.

3.6.2 Test Procedures

The testing follows FCC KDB 971168 D01 v03r01 Section 6.1.

1. The EUT was connected to spectrum analyzer and system simulator via a power divider.
2. The RF output of EUT was connected to the spectrum analyzer by RF cable and attenuator.
The path loss was compensated to the results for each measurement.
3. The middle channel for the highest RF power within the transmitting frequency was measured.
4. The conducted spurious emission for the whole frequency range was taken.
5. Make the measurement with the spectrum analyzer's RBW = 1MHz, VBW = 3MHz.
6. Set spectrum analyzer with RMS detector.
7. Taking the record of maximum spurious emission.
8. The RF fundamental frequency should be excluded against the limit line in the operating frequency band.
9. The limit line is derived from $43 + 10\log(P)$ dB below the transmitter power P(Watts)

For LTE Band 38

The limit line is derived from $55 + 10\log(P)$ dB below the transmitter power P(Watts)



3.7 Frequency Stability

3.7.1 Description of Frequency Stability Measurement

22.355

The frequency stability shall be measured by variation of ambient temperature and variation of primary supply voltage to ensure that the fundamental emission stays within the authorized frequency block. The frequency stability of the transmitter shall be maintained within $\pm 0.00025\%$ ($\pm 2.5\text{ppm}$) of the center frequency.

24.235 & 27.54

The frequency stability shall be sufficient to ensure that the fundamental emission stays within the authorized frequency block.

3.7.2 Test Procedures for Temperature Variation

The testing follows FCC KDB 971168 D01 v03r01 Section 9.0.

1. The EUT was set up in the thermal chamber and connected with the system simulator.
2. With power OFF, the temperature was decreased to -30°C and the EUT was stabilized before testing. Power was applied and the maximum change in frequency was recorded within one minute.
3. With power OFF, the temperature was raised in 10°C step up to 50°C . The EUT was stabilized at each step for at least half an hour. Power was applied and the maximum frequency change was recorded within one minute.

3.7.3 Test Procedures for Voltage Variation

The testing follows FCC KDB 971168 D01 v03r01 Section 9.0.

1. The EUT was placed in a temperature chamber at $20\pm 5^{\circ}\text{C}$ and connected with the system simulator.
2. The power supply voltage to the EUT was varied from 85% to 115% of the nominal value measured at the input to the EUT.
3. The variation in frequency was measured for the worst case.

4 Radiated Test Items

4.1 Measuring Instruments

See list of measuring instruments of this test report.

4.1.1 Test Setup

For radiated test below 30MHz

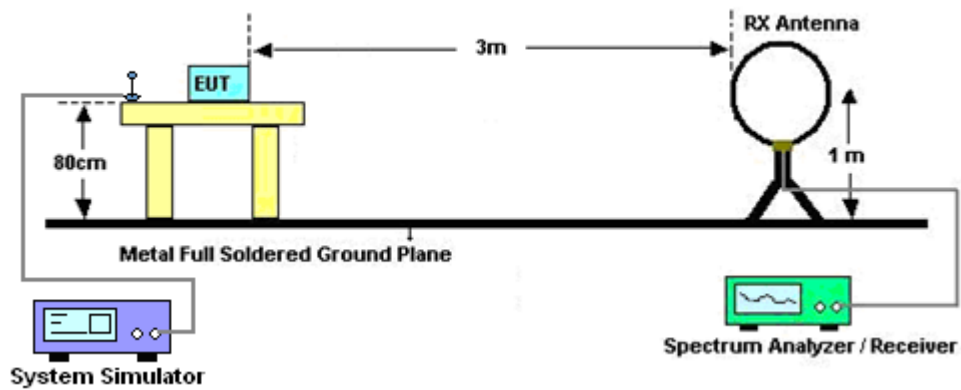

For radiated test from 30MHz to 1GHz

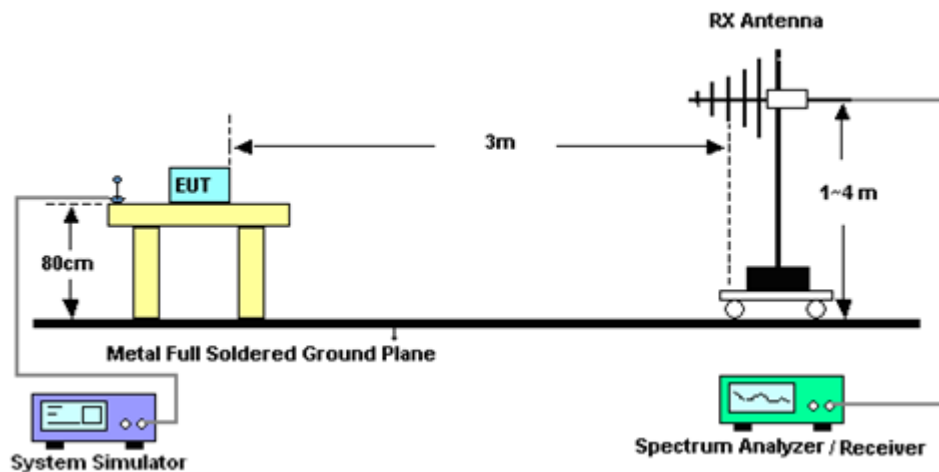

For radiated test from 1GHz to 18GHz

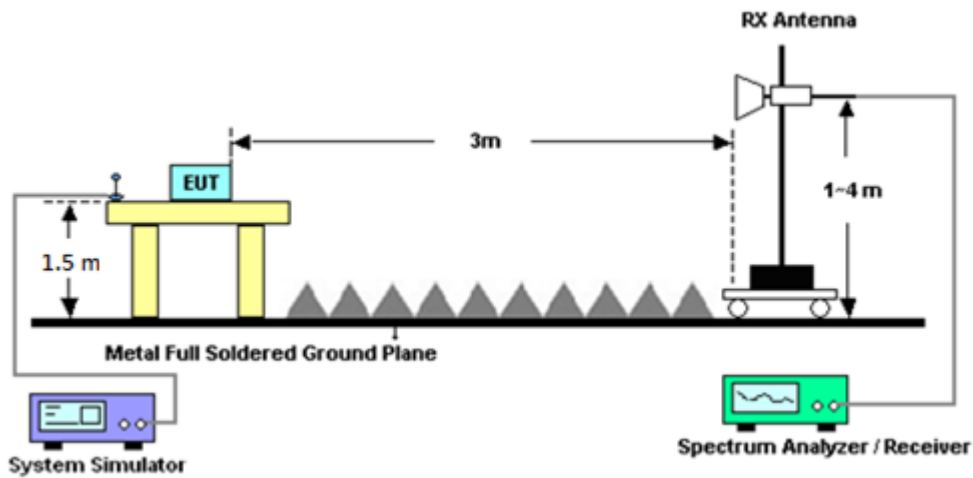

For radiated test above 18GHz

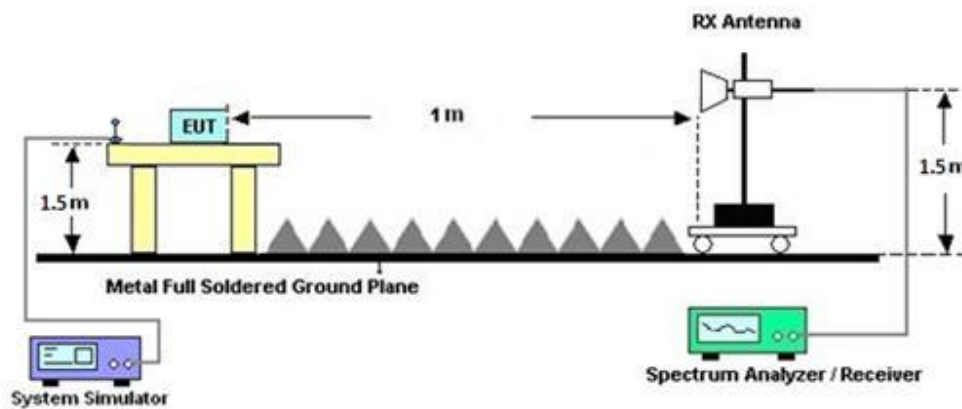

4.1.2 Test Result of Radiated Test

Please refer to Appendix B.

Note:

The low frequency, which started from 9 kHz to 30MHz, was pre-scanned and the result which was 20dB lower than the limit line was not reported.

There is adequate comparison measurement of both open-field test site and alternative test site - semi-Anechoic chamber according to 414788 D01 Radiated Test Site v01r01, and the result came out very similar.



4.2 Radiated Spurious Emission Measurement

4.2.1 Description of Radiated Spurious Emission Measurement

The radiated spurious emission was measured by substitution method according to ANSI / TIA-603-E. The power of any emission outside of the authorized operating frequency ranges must be attenuated below the transmitter power (P) by a factor of at least $43 + 10 \log (P)$ dB.

For LTE Band 38

The power of any emission outside of the authorized operating frequency ranges must be attenuated below the transmitter power (P) by a factor of at least $55 + 10 \log (P)$ dB.

The spectrum is scanned from 30 MHz up to a frequency including its 10th harmonic.

4.2.2 Test Procedures

The testing follows FCC KDB 971168 D01 v03r01 Section 7 and ANSI / TIA-603-E Section 2.2.12.

1. The EUT was placed on a turntable with 0.8 meter for frequency below 1GHz and 1.5 meter for frequency above 1GHz respectively above ground.
2. The EUT was set 3 meters from the receiving antenna, which was mounted on the antenna tower.
3. The table was rotated 360 degrees to determine the position of the highest spurious emission.
4. The height of the receiving antenna is varied between one meter and four meters to search the maximum spurious emission for both horizontal and vertical polarizations.
5. Make the measurement with the spectrum analyzer's RBW = 1MHz, VBW = 3MHz, taking the record of maximum spurious emission.
6. A horn antenna was substituted in place of the EUT and was driven by a signal generator.
7. Tune the output power of signal generator to the same emission level with EUT maximum spurious emission.
8. Taking the record of output power at antenna port.
9. Repeat step 7 to step 8 for another polarization.
10. The RF fundamental frequency should be excluded against the limit line in the operating frequency band.

The limit line is derived from $43 + 10\log(P)$ dB below the transmitter power P(Watts)

For LTE Band 38

The limit line is derived from $55 + 10\log(P)$ dB below the transmitter power P(Watts)

EIRP (dBm) = S.G. Power – Tx Cable Loss + Tx Antenna Gain

ERP (dBm) = EIRP - 2.15



5 List of Measuring Equipment

Instrument	Brand Name	Model No.	Serial No.	Characteristics	Calibration Date	Test Date	Due Date	Remark
Radio Communication Analyzer	Anritsu	MT8821C	6262025353	LTE FDD/TDD LTE-2CC DLCA/ULCA	Oct. 13, 2022	Apr. 15, 2023~ Apr. 27, 2023	Oct. 12, 2023	Conducted (TH03-HY)
Thermal Chamber	ESPEC	SH-641	92013720	-40℃ ~90℃	Sep. 07, 2022	Apr. 15, 2023~ Apr. 27, 2023	Sep. 06, 2023	Conducted (TH03-HY)
DC Power Supply	GW Instek	GPP-2323	GES906037	0V~64V : 0A~6A	Dec. 29, 2022	Apr. 15, 2023~ Apr. 27, 2023	Dec. 28, 2023	Conducted (TH03-HY)
Coupler	Warison	20dB 25W SMA Directional Coupler	#B	1-18GHz	Jan. 06, 2023	Apr. 15, 2023~ Apr. 27, 2023	Jan. 05, 2024	Conducted (TH03-HY)
Spectrum Analyzer	Rohde & Schwarz	FSV40	101908	10Hz~40GHz	Sep. 27, 2022	Apr. 15, 2023~ Apr. 27, 2023	Sep. 26, 2023	Conducted (TH03-HY)
Loop Antenna	Rohde & Schwarz	HFH2-Z2	100488	9 kHz~30 MHz	Sep 20, 2022	Apr.15, 2023~ Apr. 26, 2023	Sep 19, 2023	Radiation (03CH23-HY)
Bilog Antenna with 6dB pad	TESEQ & WOKEN	CBL 6111D & 00802N1D-06	62028 & 003	N/A	Oct. 11, 2022	Apr.15, 2023~ Apr. 26, 2023	Oct. 10, 2023	Radiation (03CH23-HY)
Amplifier	SONOMA	310N	421582	N/A	Jul. 16, 2022	Apr.15, 2023~ Apr. 26, 2023	Jul. 15, 2023	Radiation (03CH23-HY)
Double Ridged Guide Horn Antenna	RFSPIN	DRH18-E	LE2C05A18EN	1GHz~18GHz	Jul. 06, 2022	Apr.15, 2023~ Apr. 26, 2023	Jul. 05, 2023	Radiation (03CH23-HY)
SHF-EHF Horn Antenna	SCHWARZBECK	BBHA9170	00991	18GHz-40GHz	May 14, 2022	Apr.15, 2023~ Apr. 26, 2023	May 13, 2023	Radiation (03CH23-HY)
Amplifier	EMEC	EM01G18GA	060877	N/A	Sep. 29, 2022	Apr.15, 2023~ Apr. 26, 2023	Sep. 28, 2023	Radiation (03CH23-HY)
Preamplifier	EMEC	EM18G40G	060872	18-40GHz	Sep. 28, 2022	Apr.15, 2023~ Apr. 26, 2023	Sep. 27, 2023	Radiation (03CH23-HY)
Signal Analyzer	Keysight	N9010B	MY62170337	N/A	Sep. 11, 2022	Apr.15, 2023~ Apr. 26, 2023	Sep. 10, 2023	Radiation (03CH23-HY)
Hygrometer	TECPEL	DTM-303B	TP211542	N/A	Nov. 17, 2022	Apr.15, 2023~ Apr. 26, 2023	Nov. 16, 2023	Radiation (03CH23-HY)
Controller	EMEC	EM1000	N/A	Control Turn table & Ant Mast	N/A	Apr.15, 2023~ Apr. 26, 2023	N/A	Radiation (03CH23-HY)
Antenna Mast	ChainTek	MBS-520-1	N/A	1m~4m	N/A	Apr.15, 2023~ Apr. 26, 2023	N/A	Radiation (03CH23-HY)
Turn Table	ChainTek	T-200-S-1	N/A	0~360 Degree	N/A	Apr.15, 2023~ Apr. 26, 2023	N/A	Radiation (03CH23-HY)
Software	Audix	E3 6.09824_2019122	RK-002347	N/A	N/A	Apr.15, 2023~ Apr. 26, 2023	N/A	Radiation (03CH23-HY)
RF Cable	HUBER + SUHNER	SUCOFLEX 102	803951/2	9kHz~30MHz	Mar. 07, 2023	Apr.15, 2023~ Apr. 26, 2023	Mar. 06, 2024	Radiation (03CH23-HY)
RF Cable	HUBER + SUHNER	SUCOFLEX 102	804392/2,804613/2	N/A	Oct. 25, 2022	Apr.15, 2023~ Apr. 26, 2023	Oct. 24, 2023	Radiation (03CH23-HY)



6 Measurement Uncertainty

Uncertainty of Radiated Emission Measurement (30 MHz ~ 1000 MHz)

Measuring Uncertainty for a Level of Confidence of 95% ($U = 2Uc(y)$)	2.97 dB
---	---------

Uncertainty of Radiated Emission Measurement (1 GHz ~ 18 GHz)

Measuring Uncertainty for a Level of Confidence of 95% ($U = 2Uc(y)$)	3.38 dB
---	---------

Uncertainty of Radiated Emission Measurement (18 GHz ~ 40 GHz)

Measuring Uncertainty for a Level of Confidence of 95% ($U = 2Uc(y)$)	3.94 dB
---	---------



Appendix A. Test Results of Conducted Test

Conducted Output Power(Average power & ERP/EIRP)

LTE Band 2 Maximum Average Power [dBm] (GT - LC = -0.8 dB)								
BW [MHz]	RB Size	RB Offset	Mod	Lowest	Middle	Highest	EIRP (dBm)	EIRP (W)
20	1	0	QPSK	22.83	22.78	22.68	22.22	0.1667
20	1	49		23.02	22.83	22.82		
20	1	99		22.71	22.65	22.75		
20	50	0		22.04	21.69	21.97		
20	50	24		21.85	21.81	21.83		
20	50	50		21.78	21.70	22.09		
20	100	0		21.92	21.67	22.01		
20	1	0	16-QAM	21.96	21.94	21.90	21.30	0.1349
20	1	49		22.10	22.00	21.97		
20	1	99		21.90	21.82	21.86		
20	50	0		21.22	20.85	21.15		
20	50	24		21.06	21.01	20.82		
20	50	50		20.93	20.89	21.07		
20	100	0		21.11	20.84	20.98		
20	1	0	64-QAM	21.06	21.03	20.98	20.40	0.1096
20	1	49		21.20	21.12	20.89		
20	1	99		20.99	20.92	20.78		
20	50	0		20.20	19.84	20.15		
20	50	24		20.03	19.97	20.01		
20	50	50		19.92	19.84	20.22		
20	100	0		20.07	19.84	20.18		
Limit	EIRP < 2W			Result			Pass	



LTE Band 2 Maximum Average Power [dBm] (GT - LC = -0.8 dB)								
BW [MHz]	RB Size	RB Offset	Mod	Lowest	Middle	Highest	EIRP (dBm)	EIRP (W)
15	1	0	QPSK	22.90	22.81	22.66	22.16	0.1644
15	1	37		22.96	22.87	22.87		
15	1	74		22.73	22.75	22.79		
15	36	0		21.98	21.74	21.79		
15	36	20		21.86	21.81	21.80		
15	36	39		21.73	21.76	21.93		
15	75	0		21.91	21.75	21.90		
15	1	0	16-QAM	22.01	22.01	21.86	21.32	0.1355
15	1	37		22.12	22.02	21.99		
15	1	74		21.95	21.92	21.92		
15	36	0		21.14	20.96	20.77		
15	36	20		21.06	21.02	20.81		
15	36	39		20.96	20.96	20.95		
15	75	0		21.06	20.96	20.89		
15	1	0	64-QAM	21.15	21.12	20.97	20.40	0.1096
15	1	37		21.20	21.12	20.96		
15	1	74		21.02	21.03	20.84		
15	36	0		20.15	19.98	19.99		
15	36	20		20.03	20.00	20.02		
15	36	39		19.93	19.94	20.15		
15	75	0		20.05	19.93	20.07		
Limit	EIRP < 2W			Result			Pass	



LTE Band 2 Maximum Average Power [dBm] (GT - LC = -0.8 dB)								
BW [MHz]	RB Size	RB Offset	Mod	Lowest	Middle	Highest	EIRP (dBm)	EIRP (W)
10	1	0	QPSK	22.98	22.87	22.80	22.19	0.1656
10	1	25		22.99	22.87	22.91		
10	1	49		22.91	22.83	22.88		
10	25	0		22.04	21.80	21.77		
10	25	12		21.97	21.84	21.82		
10	25	25		21.83	21.82	22.00		
10	50	0		21.93	21.84	21.89		
10	1	0	16-QAM	22.08	22.03	21.95	21.32	0.1355
10	1	25		22.12	22.03	22.01		
10	1	49		22.09	21.98	21.98		
10	25	0		21.24	20.98	20.79		
10	25	12		21.14	21.04	20.84		
10	25	25		21.01	21.01	21.04		
10	50	0		21.11	20.99	20.88		
10	1	0	64-QAM	21.19	21.14	20.84	20.40	0.1096
10	1	25		21.20	21.11	20.96		
10	1	49		21.15	21.07	20.90		
10	25	0		20.18	19.94	19.96		
10	25	12		20.13	20.00	20.00		
10	25	25		20.00	19.98	20.19		
10	50	0		20.07	19.97	20.06		
Limit	EIRP < 2W			Result			Pass	



LTE Band 2 Maximum Average Power [dBm] (GT - LC = -0.8 dB)								
BW [MHz]	RB Size	RB Offset	Mod	Lowest	Middle	Highest	EIRP (dBm)	EIRP (W)
5	1	0	QPSK	23.00	22.90	22.92	22.21	0.1663
5	1	12		23.01	22.91	22.93		
5	1	24		22.97	22.85	22.91		
5	12	0		21.99	21.80	21.76		
5	12	7		21.94	21.83	21.86		
5	12	13		21.83	21.80	21.86		
5	25	0		21.92	21.83	21.84		
5	1	0	16-QAM	22.08	22.04	22.03	21.31	0.1352
5	1	12		22.11	22.05	22.01		
5	1	24		22.06	21.99	22.02		
5	12	0		21.14	20.98	20.74		
5	12	7		21.11	21.00	20.83		
5	12	13		21.01	20.98	20.84		
5	25	0		21.13	21.03	20.86		
5	1	0	64-QAM	21.22	21.16	20.95	20.45	0.1109
5	1	12		21.25	21.15	20.98		
5	1	24		21.19	21.10	20.94		
5	12	0		20.17	20.00	19.95		
5	12	7		20.11	20.01	20.05		
5	12	13		20.02	19.98	20.06		
5	25	0		20.07	19.99	20.03		
Limit	EIRP < 2W			Result			Pass	



LTE Band 2 Maximum Average Power [dBm] (GT - LC = -0.8 dB)								
BW [MHz]	RB Size	RB Offset	Mod	Lowest	Middle	Highest	EIRP (dBm)	EIRP (W)
3	1	0	QPSK	22.97	22.86	22.87	22.17	0.1648
3	1	8		22.95	22.84	22.90		
3	1	14		22.94	22.82	22.88		
3	8	0		21.93	21.78	21.83		
3	8	4		21.92	21.79	21.84		
3	8	7		21.90	21.81	21.82		
3	15	0		21.89	21.80	21.80		
3	1	0	16-QAM	22.07	22.03	21.96	21.27	0.1340
3	1	8		22.05	22.02	21.99		
3	1	14		22.04	21.98	21.97		
3	8	0		21.16	21.03	20.86		
3	8	4		21.16	21.03	20.88		
3	8	7		21.14	21.04	20.87		
3	15	0		21.12	21.02	20.84		
3	1	0	64-QAM	21.20	21.10	20.88	20.40	0.1096
3	1	8		21.20	21.11	20.92		
3	1	14		21.19	21.09	20.91		
3	8	0		20.12	19.99	20.04		
3	8	4		20.12	19.99	20.05		
3	8	7		20.10	20.01	20.06		
3	15	0		20.07	19.96	20.01		
Limit	EIRP < 2W			Result			Pass	



LTE Band 2 Maximum Average Power [dBm] (GT - LC = -0.8 dB)								
BW [MHz]	RB Size	RB Offset	Mod	Lowest	Middle	Highest	EIRP (dBm)	EIRP (W)
1.4	1	0	QPSK	22.93	22.83	22.84	22.16	0.1644
1.4	1	3		22.94	22.84	22.85		
1.4	1	5		22.93	22.82	22.85		
1.4	3	0		22.96	22.82	22.87		
1.4	3	1		22.96	22.83	22.88		
1.4	3	3		22.95	22.83	22.89		
1.4	6	0		21.95	21.81	21.86		
1.4	1	0	16-QAM	22.05	22.02	21.99	21.29	0.1346
1.4	1	3		22.09	22.02	22.02		
1.4	1	5		22.07	22.00	22.01		
1.4	3	0		21.97	21.84	21.89		
1.4	3	1		21.99	21.85	21.90		
1.4	3	3		21.95	21.83	21.88		
1.4	6	0		21.17	21.04	20.88		
1.4	1	0	64-QAM	21.18	21.11	20.91	20.40	0.1096
1.4	1	3		21.20	21.10	20.92		
1.4	1	5		21.19	21.11	20.90		
1.4	3	0		21.20	21.08	20.92		
1.4	3	1		21.20	21.09	20.91		
1.4	3	3		21.19	21.07	20.90		
1.4	6	0		20.05	19.92	19.96		
Limit	EIRP < 2W			Result			Pass	



LTE Band 5 Maximum Average Power [dBm] (GT - LC = -4.6 dB)								
BW [MHz]	RB Size	RB Offset	Mod	Lowest	Middle	Highest	ERP (dBm)	ERP (W)
10	1	0	QPSK	23.21	23.20	23.27	16.70	0.0468
10	1	25		23.26	23.32	23.45		
10	1	49		23.22	23.30	23.29		
10	25	0		22.20	22.25	22.39		
10	25	12		22.18	22.28	22.33		
10	25	25		22.26	22.27	22.18		
10	50	0		22.23	22.28	22.32		
10	1	0	16-QAM	22.40	22.40	22.46	15.79	0.0379
10	1	25		22.43	22.50	22.54		
10	1	49		22.40	22.47	22.42		
10	25	0		21.20	21.27	21.40		
10	25	12		21.18	21.28	21.33		
10	25	25		21.27	21.28	21.16		
10	50	0		21.20	21.24	21.32		
10	1	0	64-QAM	22.33	21.30	21.34	15.63	0.0366
10	1	25		22.38	21.41	21.43		
10	1	49		22.31	21.36	21.36		
10	25	0		21.18	20.25	20.36		
10	25	12		21.21	20.25	20.32		
10	25	25		21.26	20.26	20.15		
10	50	0		21.20	20.24	20.27		
Limit	ERP < 7W			Result			Pass	



LTE Band 5 Maximum Average Power [dBm] (GT - LC = -4.6 dB)								
BW [MHz]	RB Size	RB Offset	Mod	Lowest	Middle	Highest	ERP (dBm)	ERP (W)
5	1	0	QPSK	23.29	23.30	23.38	16.65	0.0462
5	1	12		23.26	23.37	23.40		
5	1	24		23.27	23.34	23.37		
5	12	0		22.20	22.32	22.42		
5	12	7		22.21	22.32	22.31		
5	12	13		22.21	22.26	22.21		
5	25	0		22.22	22.27	22.33		
5	1	0	16-QAM	22.42	22.47	22.53	15.80	0.0380
5	1	12		22.43	22.54	22.55		
5	1	24		22.43	22.48	22.47		
5	12	0		21.18	21.31	21.40		
5	12	7		21.17	21.29	21.28		
5	12	13		21.18	21.23	21.17		
5	25	0		21.21	21.28	21.31		
5	1	0	64-QAM	21.35	21.38	21.44	14.72	0.0296
5	1	12		21.33	21.45	21.47		
5	1	24		21.32	21.40	21.42		
5	12	0		20.18	20.29	20.41		
5	12	7		20.19	20.30	20.31		
5	12	13		20.21	20.25	20.19		
5	25	0		20.16	20.24	20.28		
Limit	ERP < 7W			Result			Pass	



LTE Band 5 Maximum Average Power [dBm] (GT - LC = -4.6 dB)								
BW [MHz]	RB Size	RB Offset	Mod	Lowest	Middle	Highest	ERP (dBm)	ERP (W)
3	1	0	QPSK	23.24	23.31	23.33	16.58	0.0455
3	1	8		23.17	23.29	23.33		
3	1	14		23.19	23.29	23.33		
3	8	0		22.16	22.26	22.33		
3	8	4		22.18	22.29	22.30		
3	8	7		22.15	22.27	22.25		
3	15	0		22.16	22.28	22.30		
3	1	0	16-QAM	22.42	22.49	22.50	15.75	0.0376
3	1	8		22.37	22.49	22.50		
3	1	14		22.37	22.45	22.45		
3	8	0		21.22	21.30	21.39		
3	8	4		21.21	21.33	21.35		
3	8	7		21.20	21.33	21.33		
3	15	0		21.18	21.29	21.34		
3	1	0	64-QAM	21.29	21.37	21.42	14.67	0.0293
3	1	8		21.28	21.38	21.41		
3	1	14		21.26	21.37	21.41		
3	8	0		20.18	20.27	20.34		
3	8	4		20.18	20.29	20.29		
3	8	7		20.18	20.29	20.27		
3	15	0		20.14	20.26	20.26		
Limit	ERP < 7W			Result			Pass	



LTE Band 5 Maximum Average Power [dBm] (GT - LC = -4.6 dB)								
BW [MHz]	RB Size	RB Offset	Mod	Lowest	Middle	Highest	ERP (dBm)	ERP (W)
1.4	1	0	QPSK	23.19	23.27	23.26	16.59	0.0456
1.4	1	3		23.21	23.28	23.28		
1.4	1	5		23.21	23.27	23.28		
1.4	3	0		23.21	23.29	23.30		
1.4	3	1		23.21	23.29	23.31		
1.4	3	3		23.19	23.26	23.34		
1.4	6	0		22.18	22.30	22.33		
1.4	1	0	16-QAM	22.39	22.49	22.45	15.74	0.0375
1.4	1	3		22.40	22.49	22.46		
1.4	1	5		22.35	22.48	22.44		
1.4	3	0		22.24	22.30	22.35		
1.4	3	1		22.23	22.29	22.35		
1.4	3	3		22.20	22.25	22.36		
1.4	6	0		21.21	21.32	21.38		
1.4	1	0	64-QAM	21.30	21.40	21.41	14.66	0.0292
1.4	1	3		21.31	21.39	21.38		
1.4	1	5		21.26	21.38	21.40		
1.4	3	0		21.28	21.37	21.37		
1.4	3	1		21.30	21.37	21.38		
1.4	3	3		21.25	21.33	21.39		
1.4	6	0		20.13	20.22	20.26		
Limit	ERP < 7W			Result			Pass	



LTE Band 12 Maximum Average Power [dBm] (GT - LC = -3.09 dB)								
BW [MHz]	RB Size	RB Offset	Mod	Lowest	Middle	Highest	ERP (dBm)	ERP (W)
10	1	0	QPSK	23.16	23.11	23.15	18.16	0.0655
10	1	25		23.27	23.40	23.24		
10	1	49		23.32	23.26	23.22		
10	25	0		22.10	22.39	22.12		
10	25	12		22.22	22.23	22.18		
10	25	25		22.18	22.37	22.17		
10	50	0		22.18	22.41	22.18		
10	1	0	16-QAM	22.40	22.35	22.41	17.33	0.0541
10	1	25		22.46	22.57	22.49		
10	1	49		22.57	22.49	22.43		
10	25	0		21.10	21.38	21.13		
10	25	12		21.19	21.25	21.19		
10	25	25		21.17	21.38	21.19		
10	50	0		21.16	21.38	21.15		
10	1	0	64-QAM	21.27	21.20	21.28	16.21	0.0418
10	1	25		21.34	21.44	21.38		
10	1	49		21.45	21.36	21.31		
10	25	0		20.06	20.37	20.12		
10	25	12		20.15	20.22	20.18		
10	25	25		20.14	20.36	20.16		
10	50	0		20.10	20.35	20.12		
Limit	ERP < 3W			Result			Pass	



LTE Band 12 Maximum Average Power [dBm] (GT - LC = -3.09 dB)								
BW [MHz]	RB Size	RB Offset	Mod	Lowest	Middle	Highest	ERP (dBm)	ERP (W)
5	1	0	QPSK	23.20	23.24	23.22	18.12	0.0649
5	1	12		23.25	23.36	23.24		
5	1	24		23.29	23.26	23.24		
5	12	0		22.06	22.30	22.17		
5	12	7		22.20	22.27	22.20		
5	12	13		22.19	22.24	22.06		
5	25	0		22.14	22.30	22.11		
5	1	0	16-QAM	22.43	22.46	22.45	17.36	0.0545
5	1	12		22.45	22.60	22.43		
5	1	24		22.46	22.50	22.43		
5	12	0		21.05	21.28	21.13		
5	12	7		21.15	21.25	21.16		
5	12	13		21.14	21.21	21.03		
5	25	0		21.14	21.27	21.10		
5	1	0	64-QAM	21.31	21.33	21.34	16.22	0.0419
5	1	12		21.31	21.46	21.34		
5	1	24		21.37	21.36	21.32		
5	12	0		20.05	20.26	20.13		
5	12	7		20.16	20.27	20.18		
5	12	13		20.14	20.23	20.04		
5	25	0		20.10	20.25	20.06		
Limit	ERP < 3W			Result			Pass	



LTE Band 12 Maximum Average Power [dBm] (GT - LC = -3.09 dB)								
BW [MHz]	RB Size	RB Offset	Mod	Lowest	Middle	Highest	ERP (dBm)	ERP (W)
3	1	0	QPSK	23.18	23.22	23.18	18.07	0.0641
3	1	8		23.18	23.28	23.15		
3	1	14		23.20	23.31	23.17		
3	8	0		22.16	22.22	22.15		
3	8	4		22.16	22.28	22.13		
3	8	7		22.18	22.25	22.12		
3	15	0		22.15	22.25	22.12		
3	1	0	16-QAM	22.42	22.46	22.38	17.33	0.0541
3	1	8		22.41	22.57	22.35		
3	1	14		22.39	22.52	22.39		
3	8	0		21.23	21.28	21.21		
3	8	4		21.22	21.34	21.19		
3	8	7		21.23	21.31	21.18		
3	15	0		21.19	21.27	21.15		
3	1	0	64-QAM	21.29	21.34	21.24	16.18	0.0415
3	1	8		21.28	21.42	21.26		
3	1	14		21.27	21.40	21.27		
3	8	0		20.16	20.24	20.14		
3	8	4		20.16	20.29	20.11		
3	8	7		20.15	20.27	20.10		
3	15	0		20.12	20.23	20.08		
Limit	ERP < 3W			Result			Pass	



LTE Band 12 Maximum Average Power [dBm] (GT - LC = -3.09 dB)								
BW [MHz]	RB Size	RB Offset	Mod	Lowest	Middle	Highest	ERP (dBm)	ERP (W)
1.4	1	0	QPSK	23.18	23.27	23.12	18.07	0.0641
1.4	1	3		23.24	23.30	23.17		
1.4	1	5		23.20	23.29	23.15		
1.4	3	0		23.19	23.28	23.14		
1.4	3	1		23.21	23.26	23.17		
1.4	3	3		23.20	23.31	23.19		
1.4	6	0		22.21	22.30	22.15		
1.4	1	0	16-QAM	22.43	22.54	22.33	17.32	0.0540
1.4	1	3		22.50	22.56	22.40		
1.4	1	5		22.45	22.55	22.38		
1.4	3	0		22.20	22.26	22.14		
1.4	3	1		22.20	22.27	22.17		
1.4	3	3		22.21	22.29	22.16		
1.4	6	0		21.25	21.34	21.23		
1.4	1	0	64-QAM	21.33	21.42	21.25	16.19	0.0416
1.4	1	3		21.35	21.41	21.27		
1.4	1	5		21.33	21.43	21.27		
1.4	3	0		21.29	21.34	21.21		
1.4	3	1		21.29	21.35	21.24		
1.4	3	3		21.29	21.38	21.25		
1.4	6	0		20.13	20.23	20.09		
Limit	ERP < 3W			Result			Pass	



LTE Band 17 Maximum Average Power [dBm] (GT - LC = -3.09 dB)								
BW [MHz]	RB Size	RB Offset	Mod	Lowest	Middle	Highest	ERP (dBm)	ERP (W)
10	1	0	QPSK	22.96	23.01	23.03	18.13	0.0650
10	1	25		23.16	23.14	23.16		
10	1	49		23.25	23.34	23.37		
10	25	0		22.11	22.10	22.04		
10	25	12		22.12	22.12	22.14		
10	25	25		22.34	22.30	22.22		
10	50	0		22.25	22.25	22.15		
10	1	0	16-QAM	22.19	22.23	22.27	17.30	0.0537
10	1	25		22.42	22.41	22.42		
10	1	49		22.48	22.52	22.54		
10	25	0		21.10	21.08	21.03		
10	25	12		21.10	21.12	21.14		
10	25	25		21.34	21.32	21.23		
10	50	0		21.22	21.21	21.12		
10	1	0	64-QAM	21.05	21.12	21.15	16.19	0.0416
10	1	25		21.28	21.27	21.27		
10	1	49		21.34	21.41	21.43		
10	25	0		20.10	20.07	20.03		
10	25	12		20.10	20.12	20.13		
10	25	25		20.31	20.30	20.20		
10	50	0		20.20	20.19	20.11		
Limit	ERP < 3W			Result			Pass	



LTE Band 17 Maximum Average Power [dBm] (GT - LC = -3.09 dB)								
BW [MHz]	RB Size	RB Offset	Mod	Lowest	Middle	Highest	ERP (dBm)	ERP (W)
5	1	0	QPSK	23.05	23.09	23.16	18.15	0.0653
5	1	12		23.17	23.18	23.31		
5	1	24		23.21	23.24	23.39		
5	12	0		22.15	22.09	22.14		
5	12	7		22.13	22.14	22.26		
5	12	13		22.11	22.24	22.16		
5	25	0		22.14	22.18	22.17		
5	1	0	16-QAM	22.24	22.35	22.38	17.33	0.0541
5	1	12		22.42	22.44	22.48		
5	1	24		22.46	22.45	22.57		
5	12	0		21.10	21.08	21.10		
5	12	7		21.10	21.11	21.21		
5	12	13		21.04	21.21	21.12		
5	25	0		21.11	21.16	21.17		
5	1	0	64-QAM	21.16	21.21	21.27	16.21	0.0418
5	1	12		21.29	21.28	21.40		
5	1	24		21.32	21.33	21.45		
5	12	0		20.14	20.09	20.10		
5	12	7		20.11	20.12	20.23		
5	12	13		20.09	20.20	20.14		
5	25	0		20.08	20.15	20.11		
Limit	ERP < 3W			Result			Pass	



LTE Band 38 Maximum Average Power [dBm] (GT - LC = -3.49 dB)								
BW [MHz]	RB Size	RB Offset	Mod	Lowest	Middle	Highest	EIRP (dBm)	EIRP (W)
20	1	0	QPSK	23.30	23.37	23.44	20.24	0.1057
20	1	49		23.51	23.57	23.73		
20	1	99		23.40	23.51	23.58		
20	50	0		22.42	22.51	22.61		
20	50	24		22.47	22.54	22.64		
20	50	50		22.50	22.54	22.55		
20	100	0		22.43	22.51	22.55		
20	1	0	16-QAM	22.37	22.38	22.41	19.09	0.0811
20	1	49		22.53	22.57	22.58		
20	1	99		22.41	22.48	22.54		
20	50	0		21.42	21.51	21.62		
20	50	24		21.48	21.55	21.68		
20	50	50		21.49	21.57	21.57		
20	100	0		21.43	21.52	21.57		
20	1	0	64-QAM	21.08	21.12	21.19	17.83	0.0607
20	1	49		21.24	21.30	21.32		
20	1	99		21.14	21.23	21.29		
20	50	0		20.38	20.46	20.56		
20	50	24		20.42	20.48	20.59		
20	50	50		20.47	20.50	20.52		
20	100	0		20.41	20.49	20.52		
Limit	EIRP < 2W			Result			Pass	



LTE Band 38 Maximum Average Power [dBm] (GT - LC = -3.49 dB)								
BW [MHz]	RB Size	RB Offset	Mod	Lowest	Middle	Highest	EIRP (dBm)	EIRP (W)
15	1	0	QPSK	23.42	23.44	23.53	20.17	0.1040
15	1	37		23.53	23.60	23.66		
15	1	74		23.47	23.54	23.62		
15	36	0		22.44	22.50	22.57		
15	36	20		22.45	22.52	22.57		
15	36	39		22.45	22.54	22.54		
15	75	0		22.47	22.54	22.61		
15	1	0	16-QAM	22.42	22.41	22.47	19.09	0.0811
15	1	37		22.50	22.54	22.58		
15	1	74		22.45	22.49	22.58		
15	36	0		21.39	21.45	21.54		
15	36	20		21.42	21.49	21.55		
15	36	39		21.44	21.53	21.49		
15	75	0		21.47	21.53	21.59		
15	1	0	64-QAM	21.14	21.15	21.25	17.88	0.0614
15	1	37		21.23	21.30	21.37		
15	1	74		21.20	21.25	21.34		
15	36	0		20.40	20.46	20.57		
15	36	20		20.42	20.49	20.56		
15	36	39		20.43	20.50	20.51		
15	75	0		20.43	20.49	20.54		
Limit	EIRP < 2W			Result			Pass	



LTE Band 38 Maximum Average Power [dBm] (GT - LC = -3.49 dB)								
BW [MHz]	RB Size	RB Offset	Mod	Lowest	Middle	Highest	EIRP (dBm)	EIRP (W)
10	1	0	QPSK	23.51	23.56	23.63	20.22	0.1052
10	1	25		23.53	23.61	23.69		
10	1	49		23.55	23.60	23.71		
10	25	0		22.42	22.56	22.64		
10	25	12		22.48	22.52	22.61		
10	25	25		22.48	22.53	22.61		
10	50	0		22.50	22.53	22.61		
10	1	0	16-QAM	22.53	22.53	22.58	19.15	0.0822
10	1	25		22.52	22.56	22.61		
10	1	49		22.56	22.53	22.64		
10	25	0		21.45	21.60	21.67		
10	25	12		21.50	21.54	21.61		
10	25	25		21.50	21.54	21.62		
10	50	0		21.49	21.55	21.62		
10	1	0	64-QAM	21.24	21.29	21.35	17.94	0.0622
10	1	25		21.23	21.30	21.40		
10	1	49		21.26	21.32	21.43		
10	25	0		20.45	20.57	20.64		
10	25	12		20.48	20.52	20.62		
10	25	25		20.52	20.54	20.62		
10	50	0		20.44	20.49	20.59		
Limit	EIRP < 2W			Result			Pass	



LTE Band 38 Maximum Average Power [dBm] (GT - LC = -3.49 dB)								
BW [MHz]	RB Size	RB Offset	Mod	Lowest	Middle	Highest	EIRP (dBm)	EIRP (W)
5	1	0	QPSK	23.49	23.61	23.70	20.23	0.1054
5	1	12		23.54	23.63	23.72		
5	1	24		23.52	23.61	23.72		
5	12	0		22.44	22.56	22.66		
5	12	7		22.44	22.50	22.62		
5	12	13		22.47	22.52	22.62		
5	25	0		22.45	22.54	22.62		
5	1	0	16-QAM	22.49	22.55	22.62	19.16	0.0824
5	1	12		22.51	22.55	22.61		
5	1	24		22.53	22.56	22.65		
5	12	0		21.39	21.49	21.59		
5	12	7		21.38	21.44	21.55		
5	12	13		21.40	21.46	21.58		
5	25	0		21.46	21.57	21.65		
5	1	0	64-QAM	21.24	21.35	21.44	17.96	0.0625
5	1	12		21.25	21.33	21.42		
5	1	24		21.25	21.34	21.45		
5	12	0		20.41	20.53	20.64		
5	12	7		20.39	20.46	20.58		
5	12	13		20.43	20.47	20.59		
5	25	0		20.45	20.55	20.64		
Limit	EIRP < 2W			Result			Pass	



LTE Band 2

Peak-to-Average Ratio

Mode	LTE Band 2 / 20MHz			
Mod.	QPSK	16QAM	64QAM	Limit: 13dB
RB Size	Full RB	Full RB	Full RB	Result
Middle CH	4.64	5.59	5.88	PASS



LTE Band 2 / 20MHz / QPSK

Middle Channel / Full RB

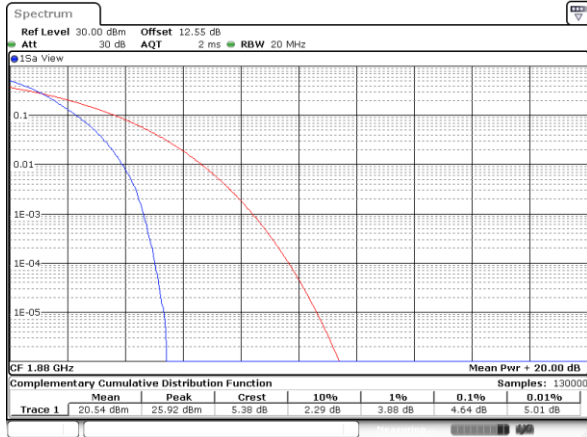

Date: 15.APR.2023 16:09:14

LTE Band 2 / 20MHz / 16QAM

Middle Channel / Full RB

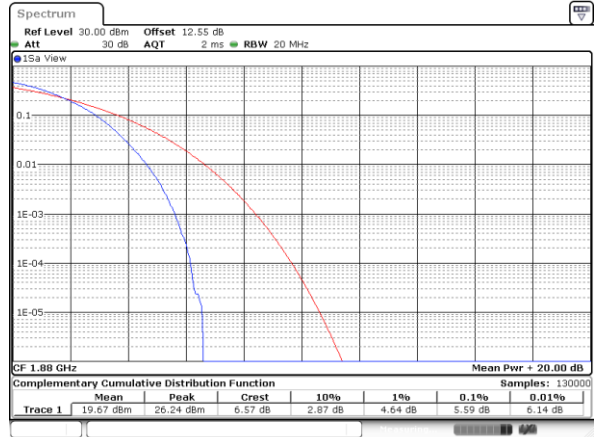

Date: 15.APR.2023 16:08:49

LTE Band 2 / 20MHz / 64QAM

Middle Channel / Full RB

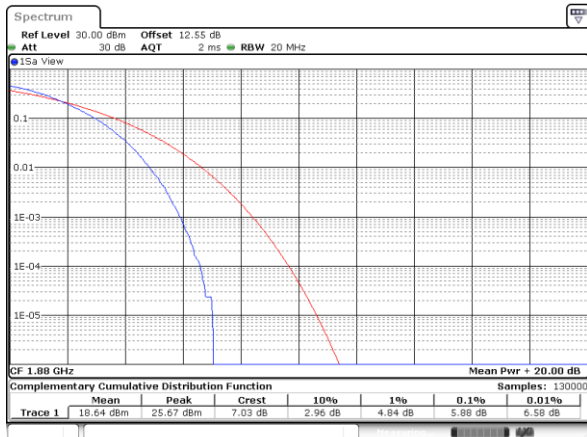

Date: 15.APR.2023 16:09:39



26dB Bandwidth

Mode	LTE Band 2 : 26dB BW(MHz)											
BW	1.4MHz		3MHz		5MHz		10MHz		15MHz		20MHz	
Mod.	QPSK	16QAM	QPSK	16QAM	QPSK	16QAM	QPSK	16QAM	QPSK	16QAM	QPSK	16QAM
Middle CH	1.28	1.28	2.98	2.94	4.90	4.81	9.69	9.83	14.18	14.42	18.74	18.82
Mode	LTE Band 2 : 26dB BW(MHz)											
BW	1.4MHz		3MHz		5MHz		10MHz		15MHz		20MHz	
Mod.	64QAM		64QAM		64QAM		64QAM		64QAM		64QAM	
Middle CH	1.28		2.99		4.91		9.65		14.48		18.74	



LTE Band 2

Middle Channel / 1.4MHz / QPSK

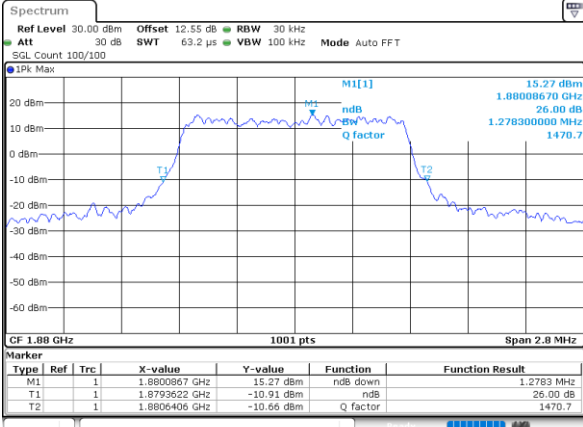

Date: 15.APR.2023 15:08:37

Middle Channel / 1.4MHz / 16QAM

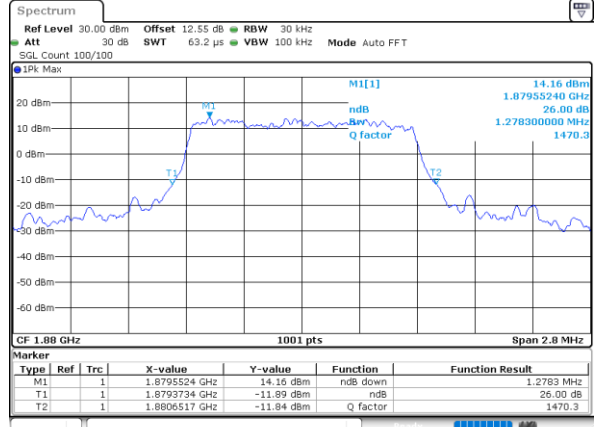

Date: 15.APR.2023 15:10:01

Middle Channel / 3MHz / QPSK

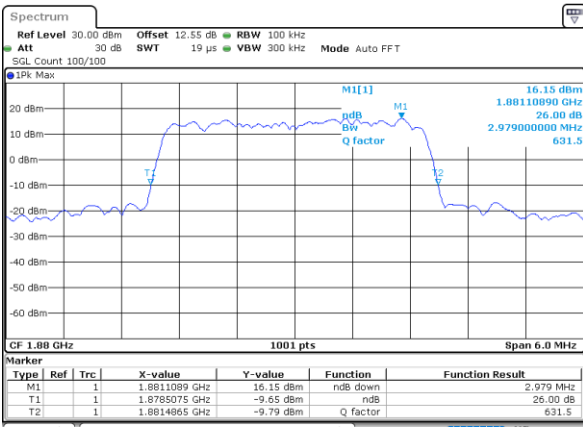

Date: 15.APR.2023 15:18:01

Middle Channel / 3MHz / 16QAM

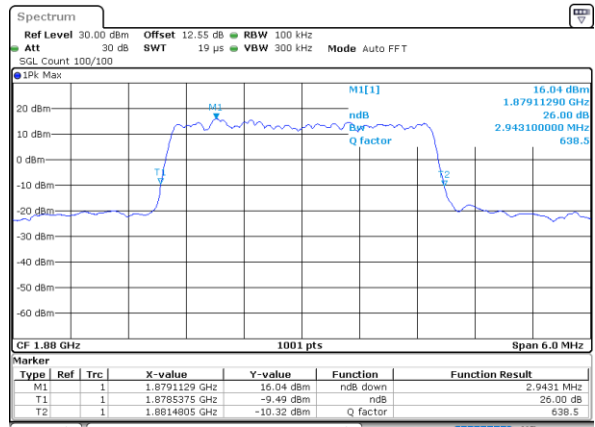

Date: 15.APR.2023 15:18:25

Middle Channel / 5MHz / QPSK

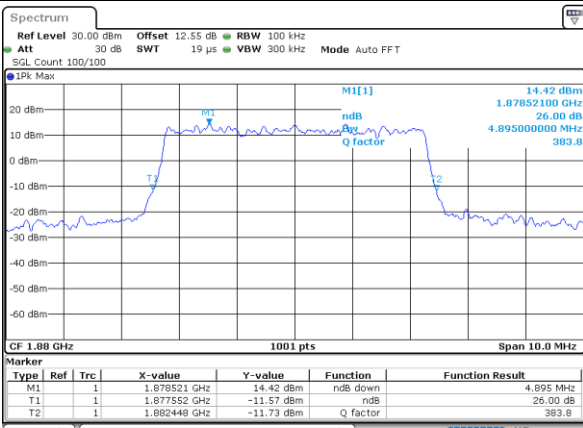

Date: 15.APR.2023 15:29:25

Middle Channel / 5MHz / 16QAM

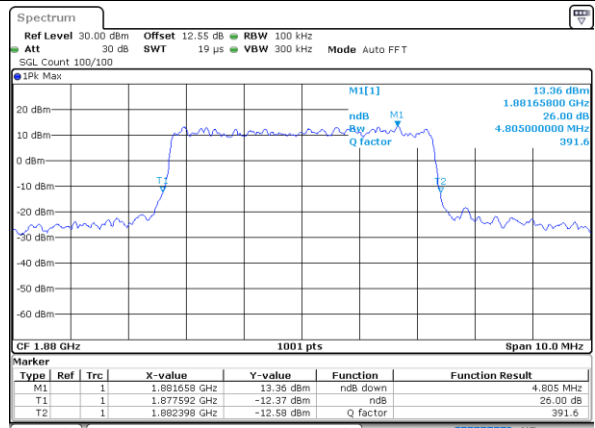

Date: 15.APR.2023 15:29:49



LTE Band 2

Middle Channel / 10MHz / QPSK

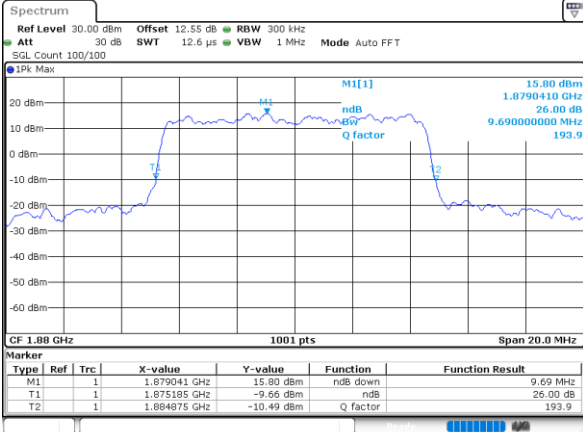

Date: 15_APR.2023 15:40:50

Middle Channel / 10MHz / 16QAM

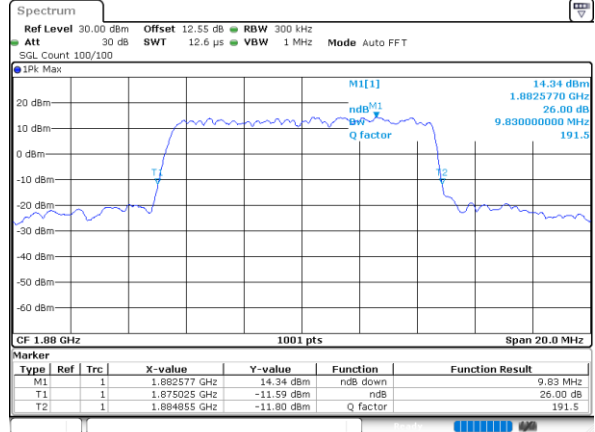

Date: 15_APR.2023 15:41:13

Middle Channel / 15MHz / QPSK

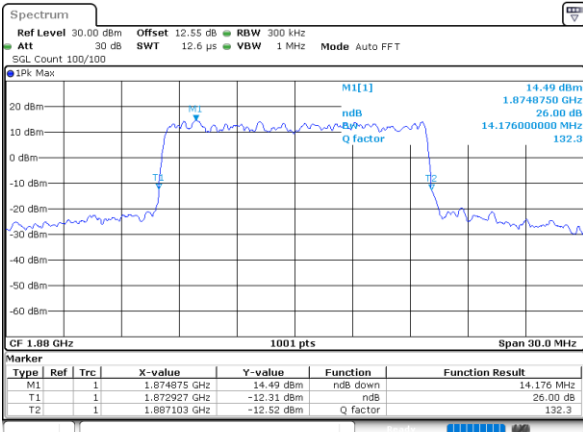

Date: 15_APR.2023 15:52:14

Middle Channel / 15MHz / 16QAM

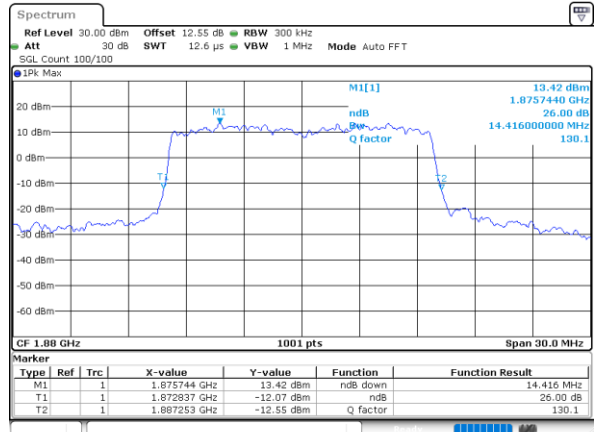

Date: 15_APR.2023 15:52:17

Middle Channel / 20MHz / QPSK

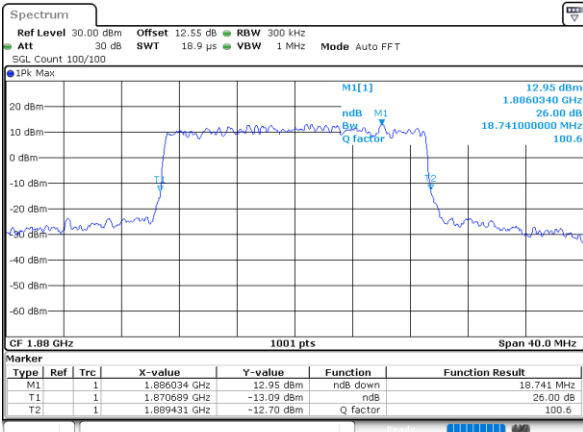

Date: 15_APR.2023 16:03:38

Middle Channel / 20MHz / 16QAM

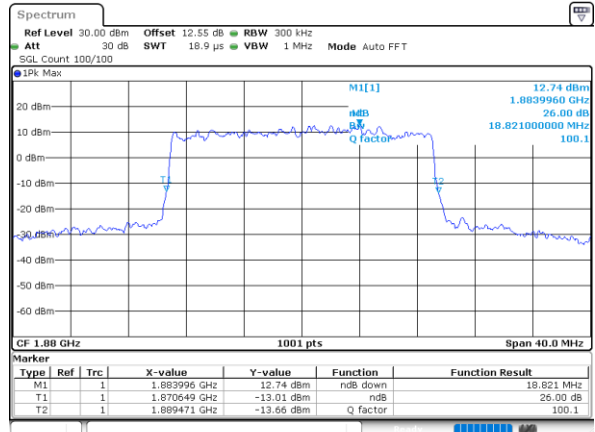

Date: 15_APR.2023 16:04:02



LTE Band 2

Middle Channel / 1.4MHz / 64QAM

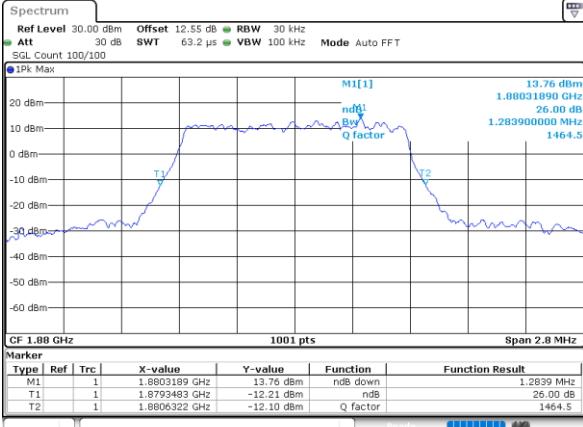

Date: 15.APR.2023 15:00:50

Middle Channel / 3MHz / 64QAM

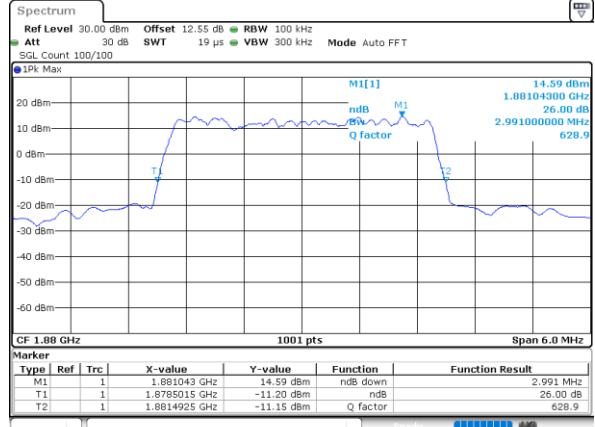

Date: 15.APR.2023 15:25:32

Middle Channel / 5MHz / 64QAM

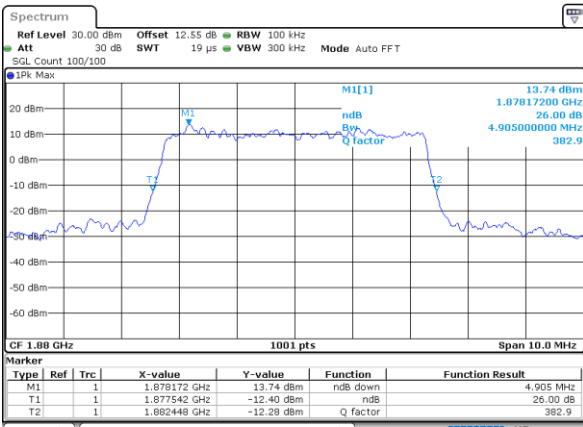

Date: 15.APR.2023 15:33:17

Middle Channel / 10MHz / 64QAM

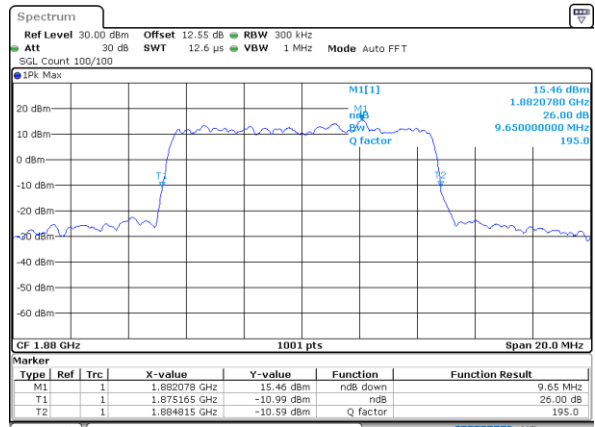

Date: 15.APR.2023 15:48:21

Middle Channel / 15MHz / 64QAM

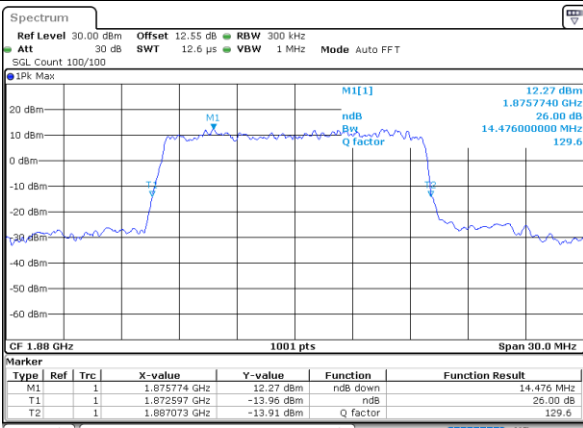

Date: 15.APR.2023 15:56:06

Middle Channel / 20MHz / 64QAM

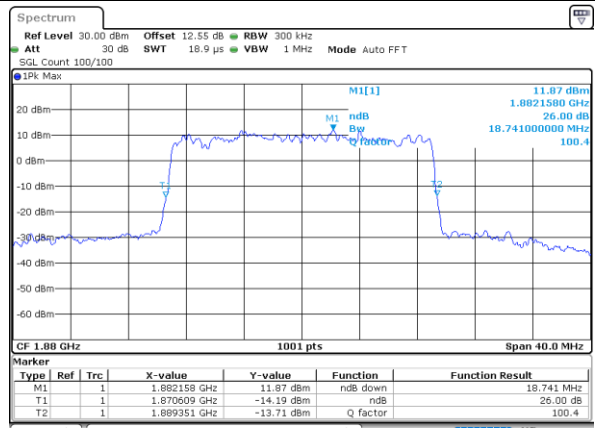

Date: 15.APR.2023 16:07:31



Occupied Bandwidth

Mode	LTE Band 2 : 99%OBW(MHz)											
BW	1.4MHz		3MHz		5MHz		10MHz		15MHz		20MHz	
Mod.	QPSK	16QAM	QPSK	16QAM	QPSK	16QAM	QPSK	16QAM	QPSK	16QAM	QPSK	16QAM
Middle CH	1.09	1.09	2.71	2.71	4.48	4.49	9.05	9.01	13.40	13.46	17.78	17.82
Mode	LTE Band 2 : 99%OBW(MHz)											
BW	1.4MHz		3MHz		5MHz		10MHz		15MHz		20MHz	
Mod.	64QAM		64QAM		64QAM		64QAM		64QAM		64QAM	
Middle CH	1.09		2.71		4.49		9.01		13.40		17.78	



LTE Band 2

Middle Channel / 1.4MHz / QPSK

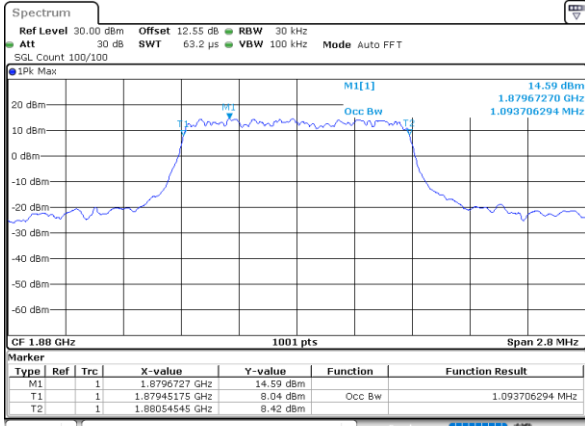

Date: 15.APR.2023 15:07:50

Middle Channel / 1.4MHz / 16QAM

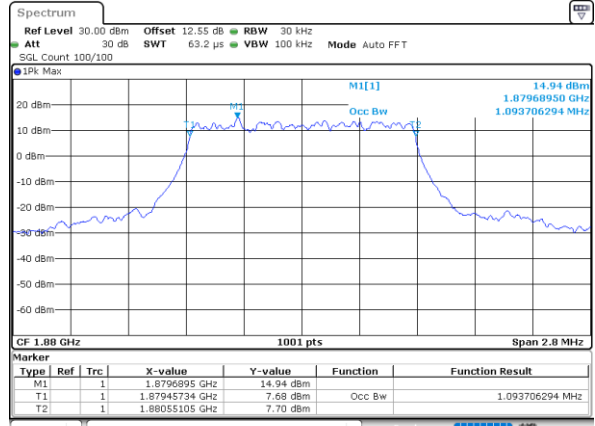

Date: 15.APR.2023 15:08:14

Middle Channel / 3MHz / QPSK

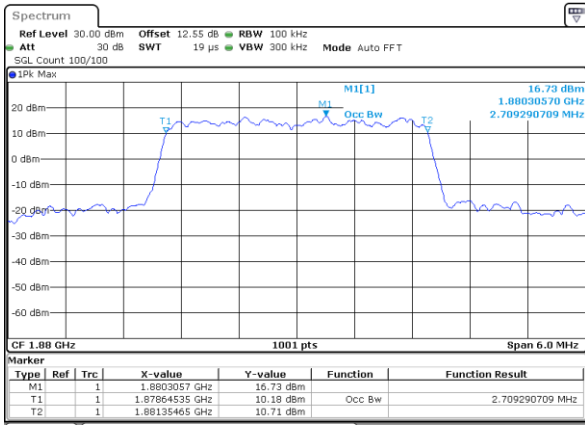

Date: 15.APR.2023 15:17:14

Middle Channel / 3MHz / 16QAM

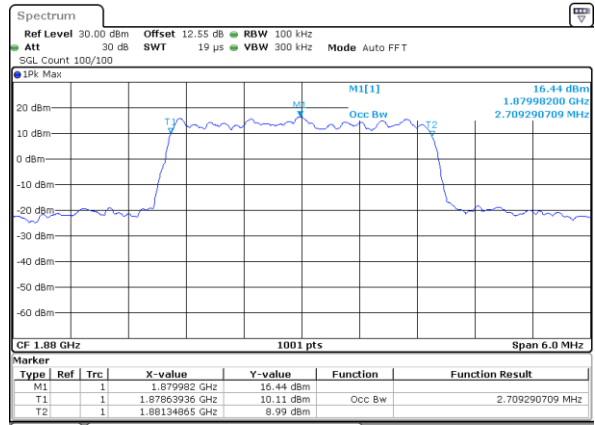

Date: 15.APR.2023 15:17:38

Middle Channel / 5MHz / QPSK

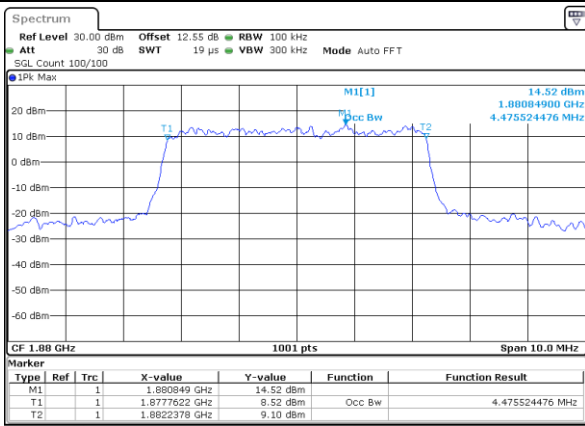

Date: 15.APR.2023 15:28:38

Middle Channel / 5MHz / 16QAM

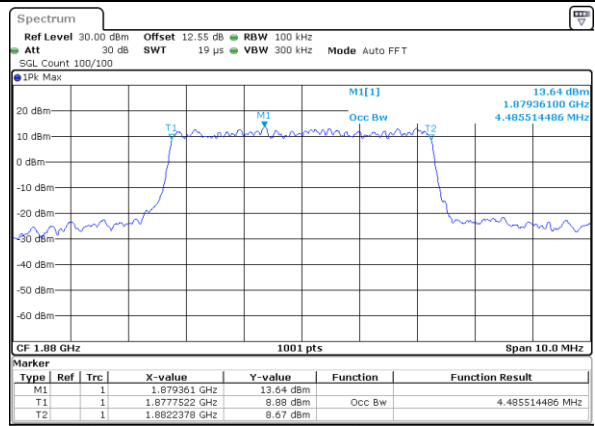

Date: 15.APR.2023 15:29:02



LTE Band 2

Middle Channel / 10MHz / QPSK

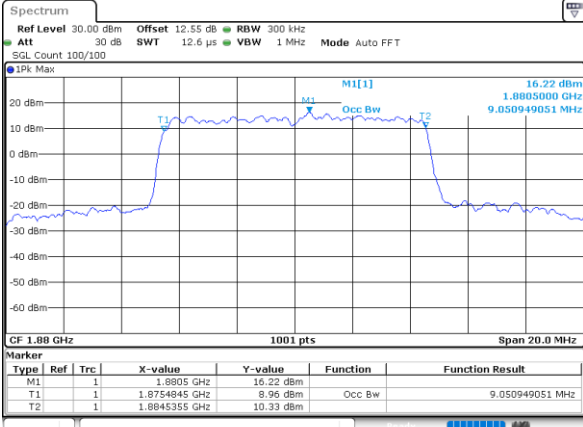

Date: 15.APR.2023 15:40:03

Middle Channel / 10MHz / 16QAM

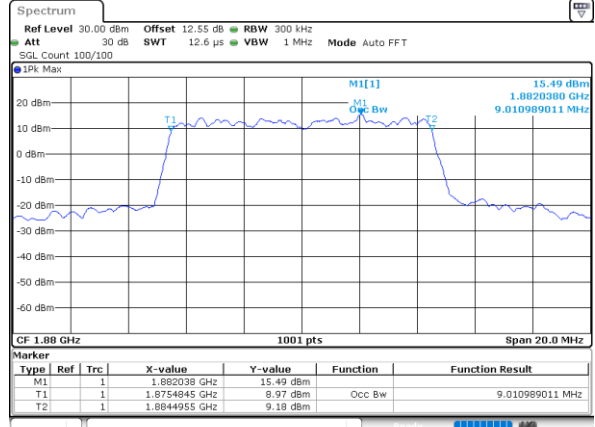

Date: 15.APR.2023 15:40:26

Middle Channel / 15MHz / QPSK

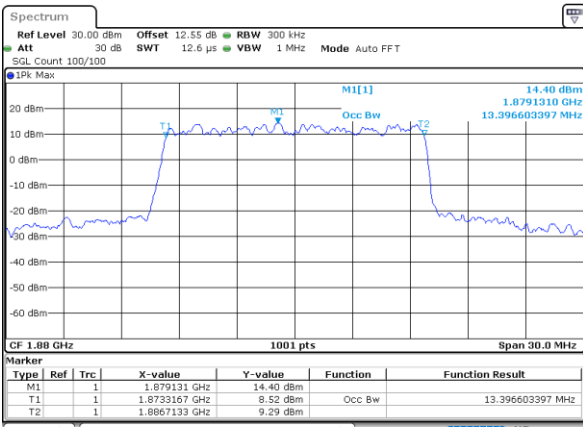

Date: 15.APR.2023 15:51:27

Middle Channel / 15MHz / 16QAM

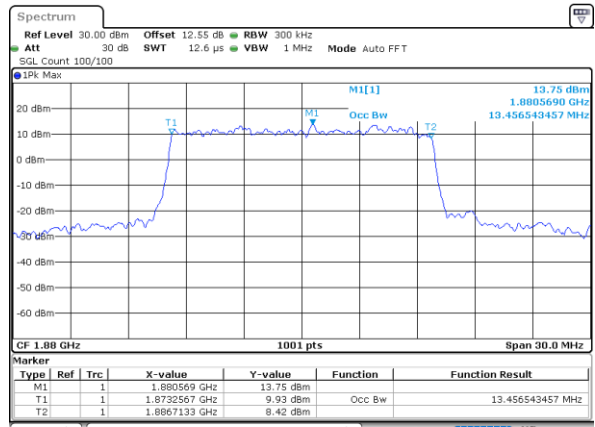

Date: 15.APR.2023 15:51:50

Middle Channel / 20MHz / QPSK

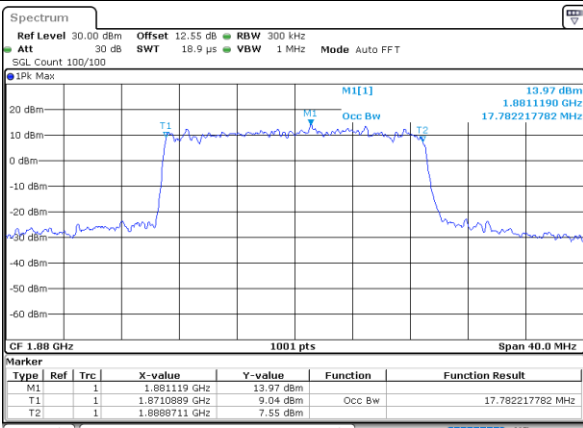

Date: 15.APR.2023 16:02:51

Middle Channel / 20MHz / 16QAM

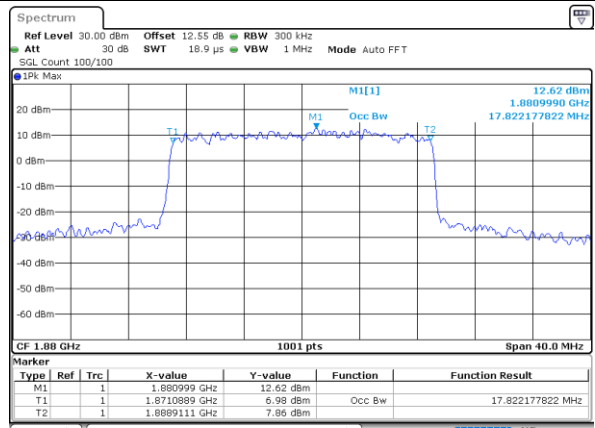

Date: 15.APR.2023 16:03:15



LTE Band 2

Middle Channel / 1.4MHz / 64QAM

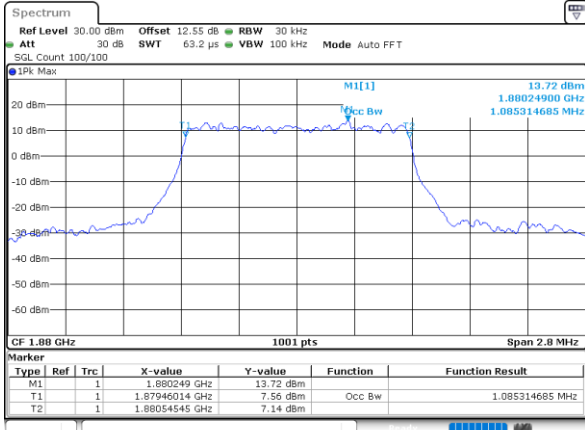

Date: 15.APR.2023 15:00:26

Middle Channel / 3MHz / 64QAM

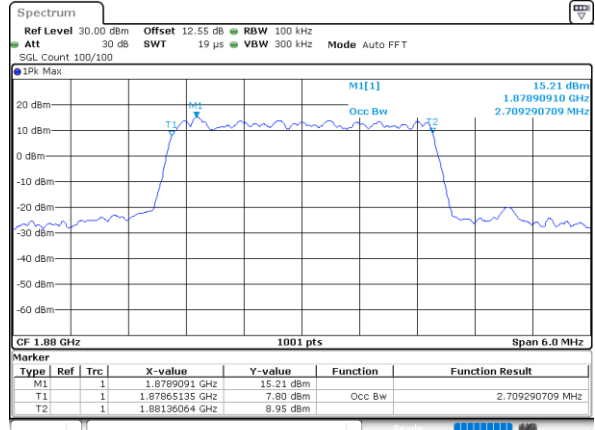

Date: 15.APR.2023 15:25:09

Middle Channel / 5MHz / 64QAM

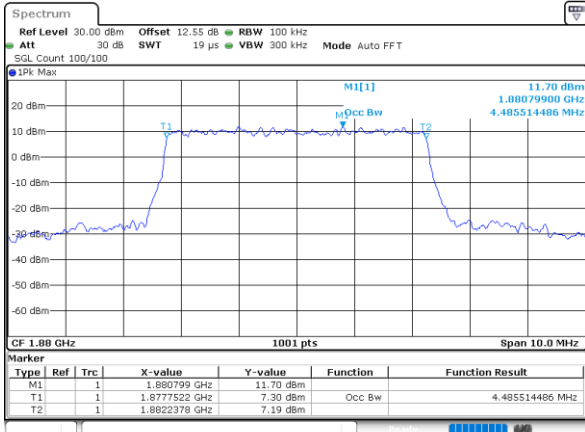

Date: 15.APR.2023 15:32:54

Middle Channel / 10MHz / 64QAM

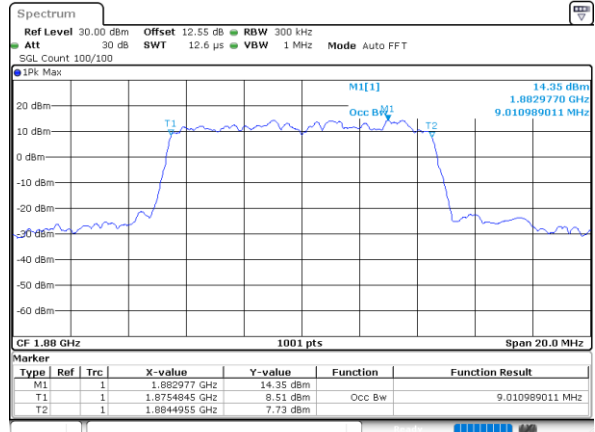

Date: 15.APR.2023 15:47:57

Middle Channel / 15MHz / 64QAM

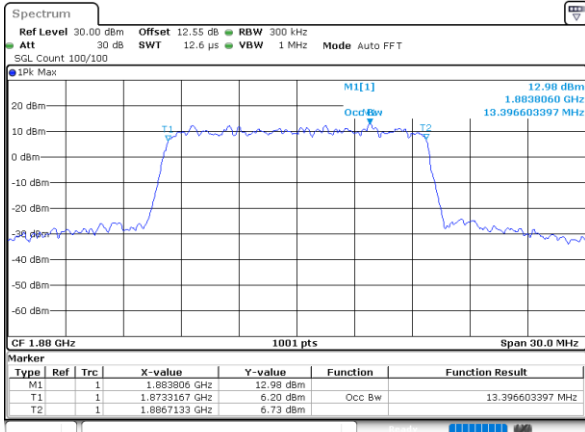

Date: 15.APR.2023 15:55:43

Middle Channel / 20MHz / 64QAM

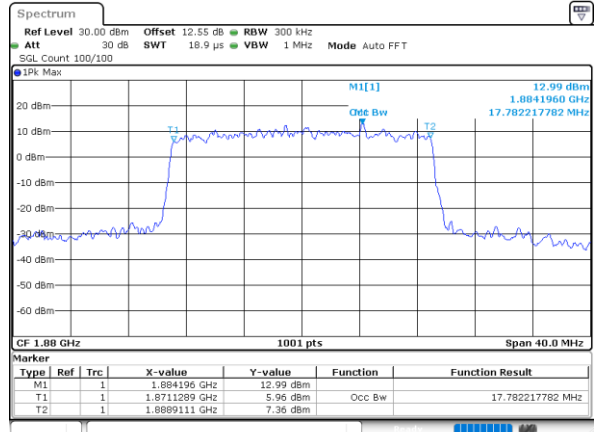

Date: 15.APR.2023 16:07:07



Conducted Band Edge

LTE Band 2 / 1.4MHz / QPSK

Lowest Band Edge / 1RB

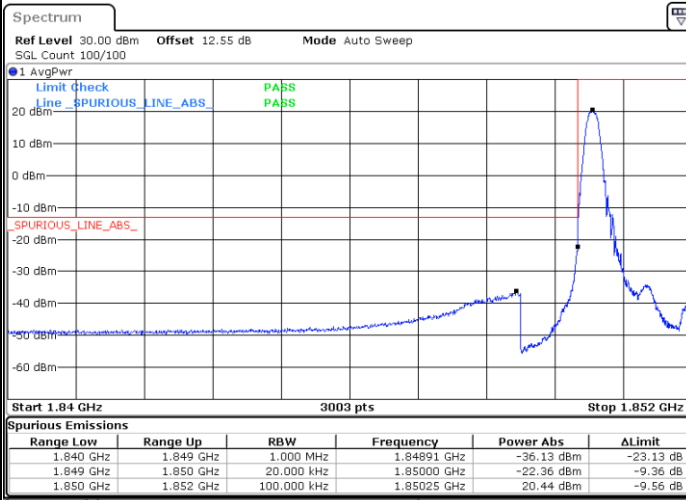

Date: 15.APR.2023 15:03:31

Highest Band Edge / 1RB

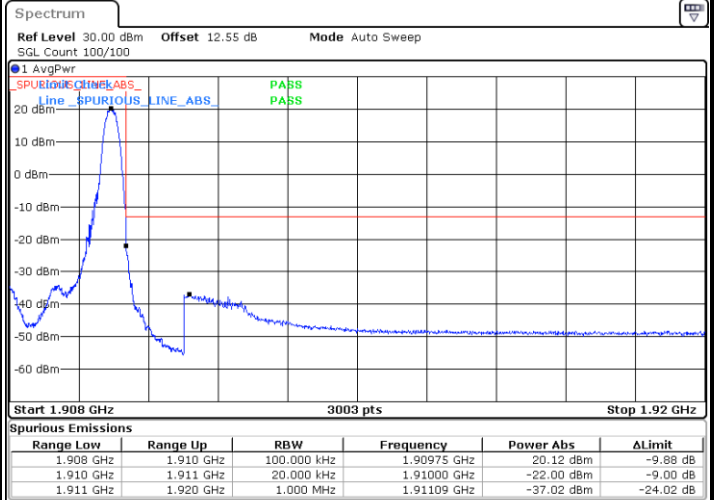

Date: 15.APR.2023 15:11:06

Lowest Band Edge / Full RB

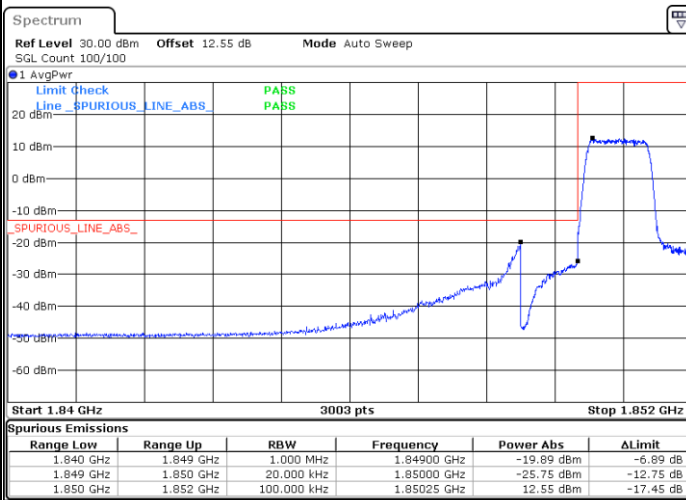

Date: 15.APR.2023 15:05:19

Highest Band Edge / Full RB

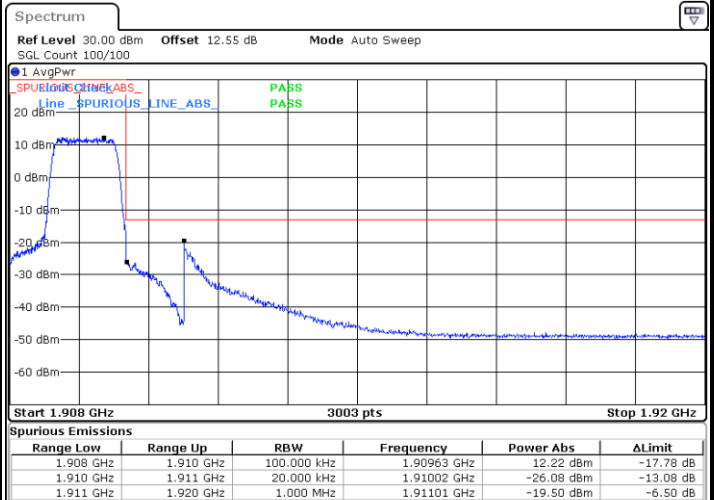

Date: 15.APR.2023 15:12:54



LTE Band 2 / 1.4MHz / 16QAM

Lowest Band Edge / 1 RB

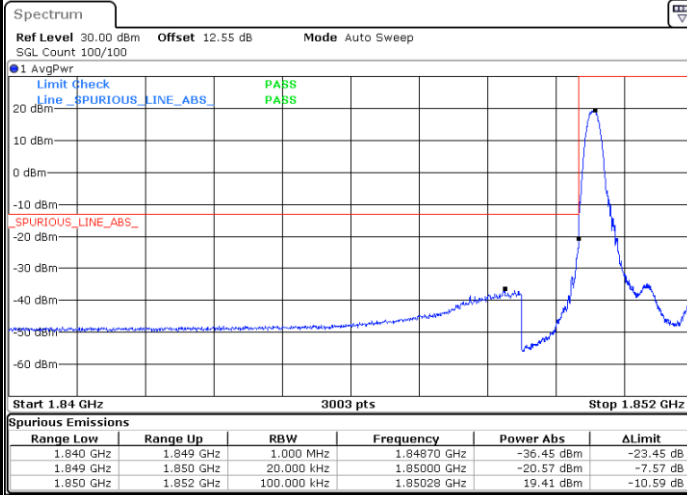

Date: 15.APR.2023 15:04:24

Highest Band Edge / 1 RB

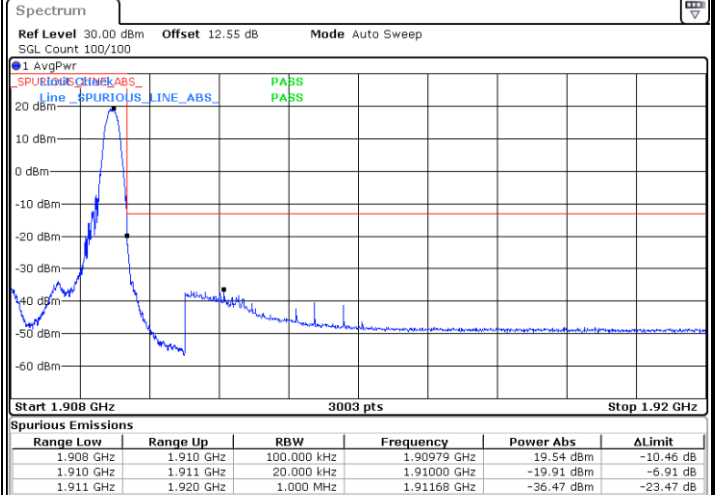

Date: 15.APR.2023 15:12:00

Lowest Band Edge / Full RB

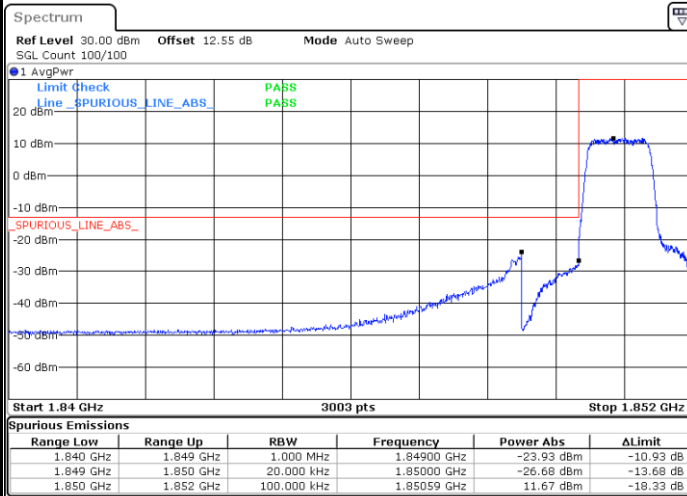

Date: 15.APR.2023 15:06:12

Highest Band Edge / Full RB

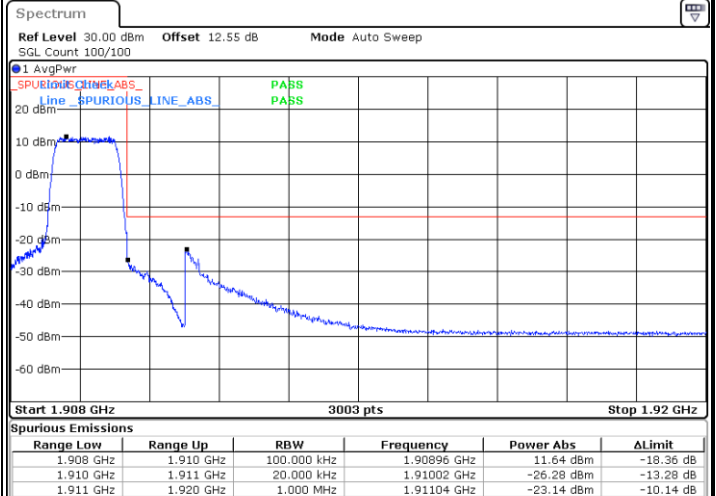

Date: 15.APR.2023 15:13:48



LTE Band 2 / 1.4MHz / 64QAM

Lowest Band Edge / 1 RB

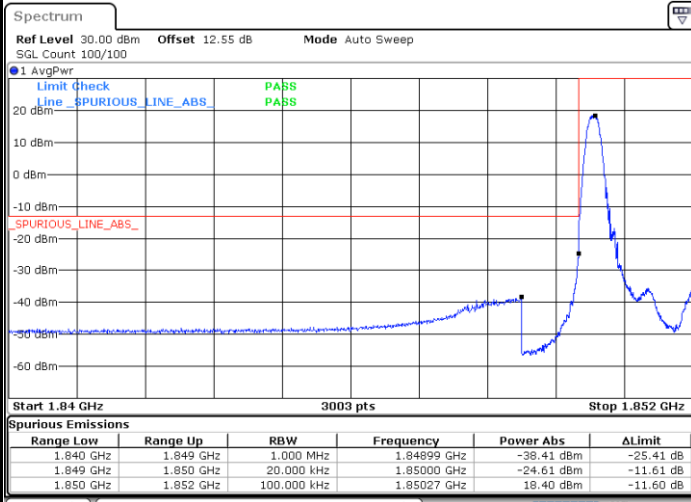

Date: 15.APR.2023 14:59:07

Highest Band Edge / 1 RB

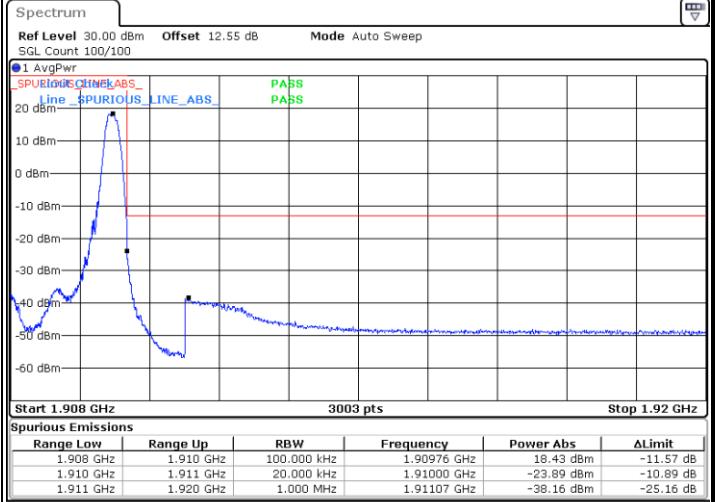

Date: 15.APR.2023 15:01:42

Lowest Band Edge / Full RB

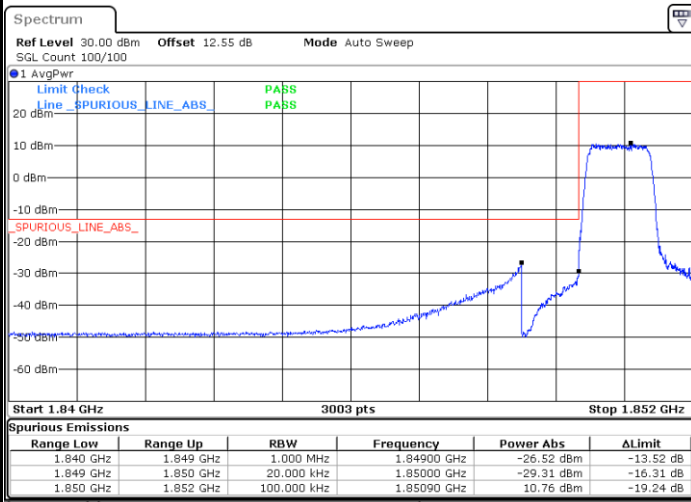

Date: 15.APR.2023 15:00:02

Highest Band Edge / Full RB

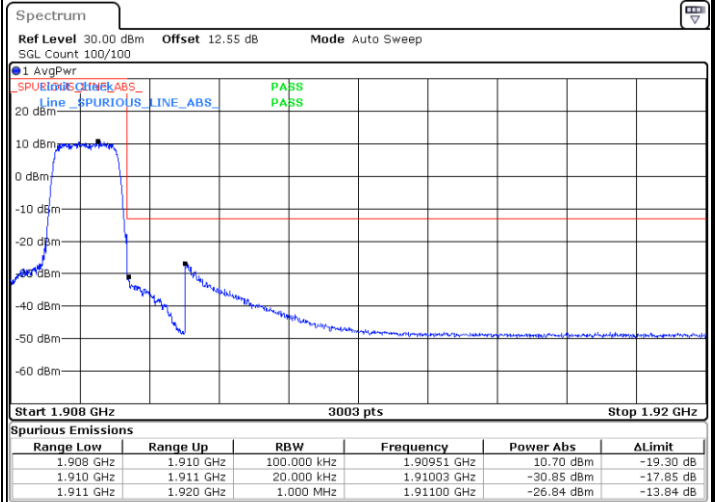

Date: 15.APR.2023 15:02:36



LTE Band 2 / 3MHz / QPSK

Lowest Band Edge / Full RB

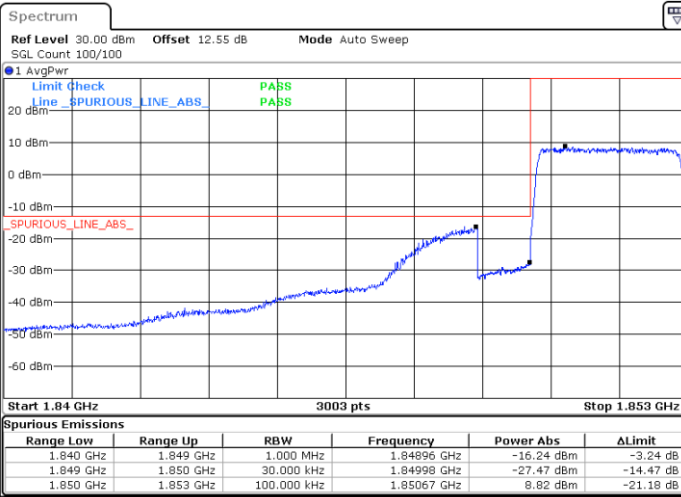

Date: 15.APR.2023 15:15:56

Highest Band Edge / Full RB

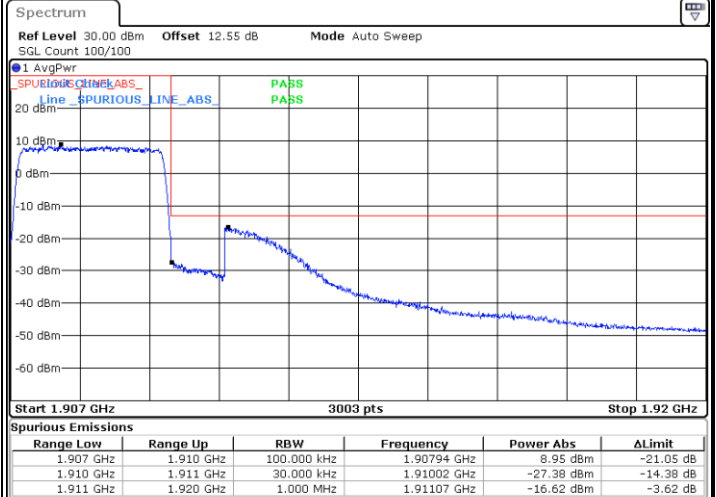

Date: 15.APR.2023 15:22:56

LTE Band 2 / 3MHz / 16QAM

Lowest Band Edge / Full RB

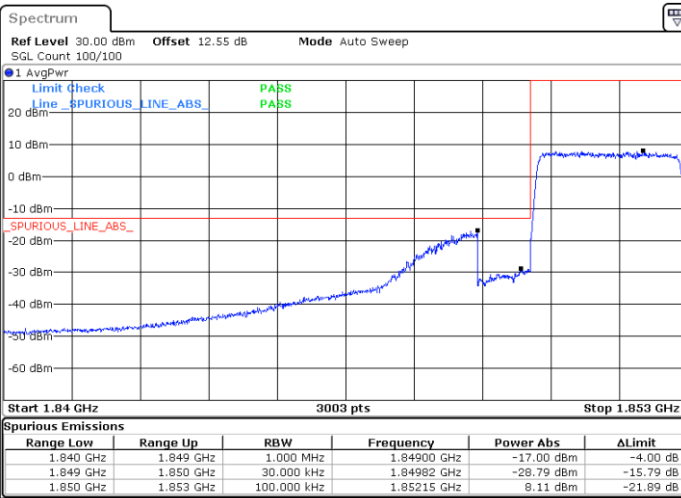

Date: 15.APR.2023 15:16:50

Highest Band Edge / Full RB

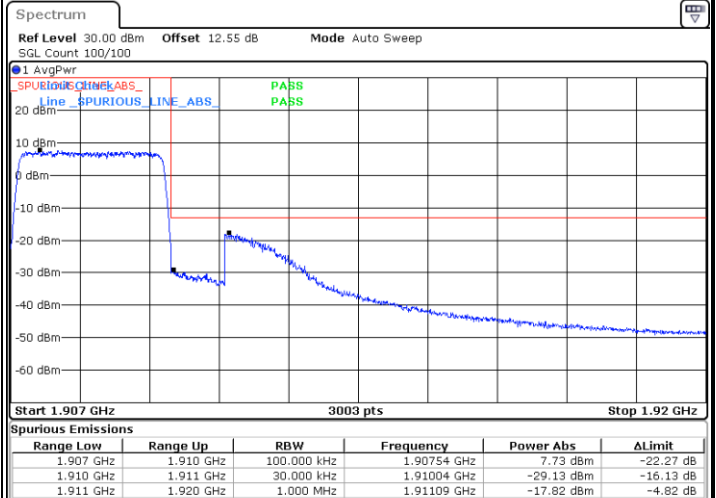

Date: 15.APR.2023 15:23:50



LTE Band 2 / 3MHz / 64QAM

Lowest Band Edge / Full RB

Highest Band Edge / Full RB

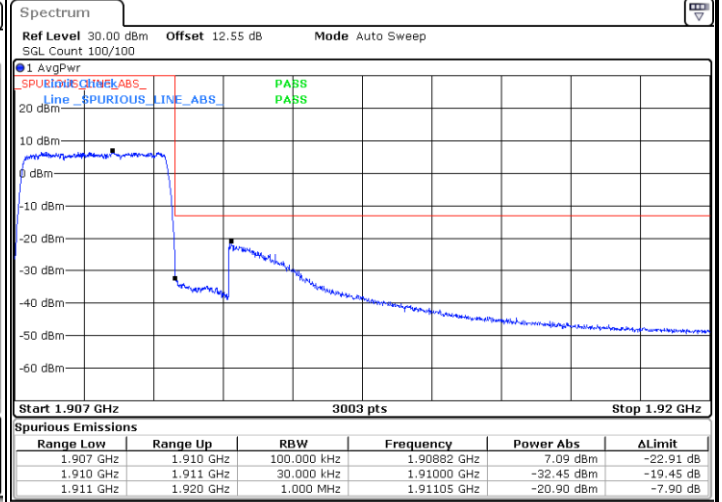
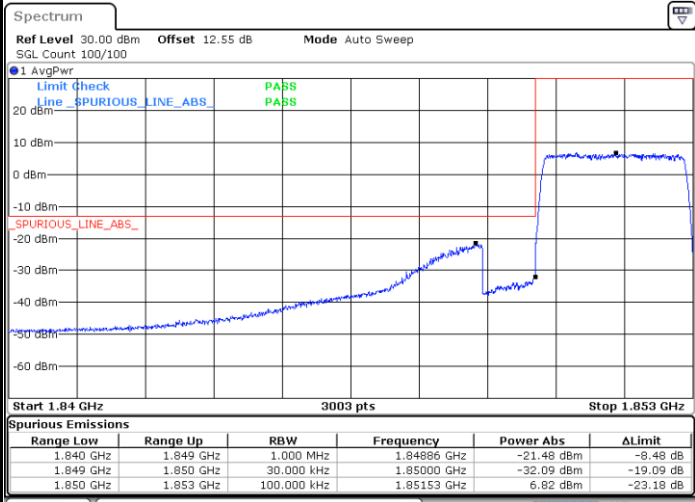

Date: 15.APR.2023 15:24:44

Date: 15.APR.2023 15:26:25



LTE Band 2 / 5MHz / QPSK

Lowest Band Edge / Full RB

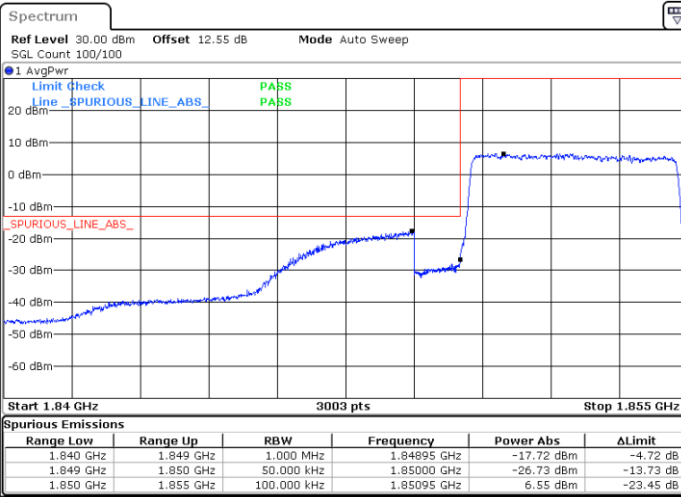

Highest Band Edge / Full RB

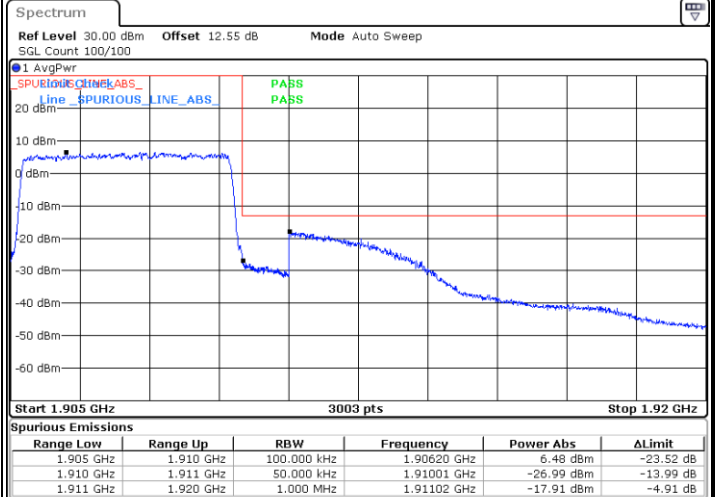

LTE Band 2 / 5MHz / 16QAM

Lowest Band Edge / Full RB

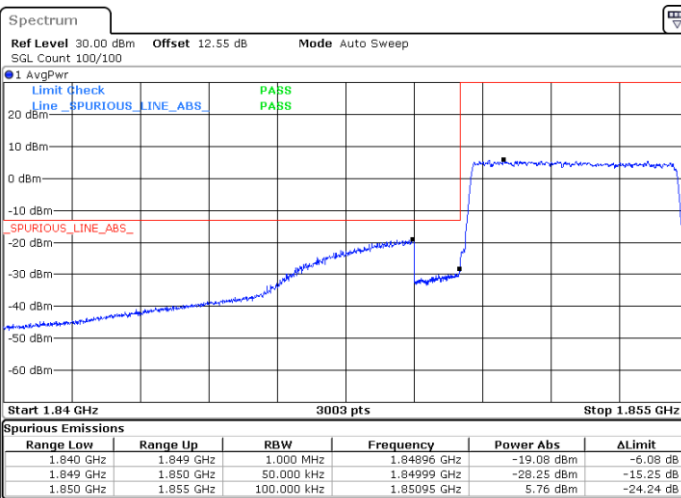

Highest Band Edge / Full RB

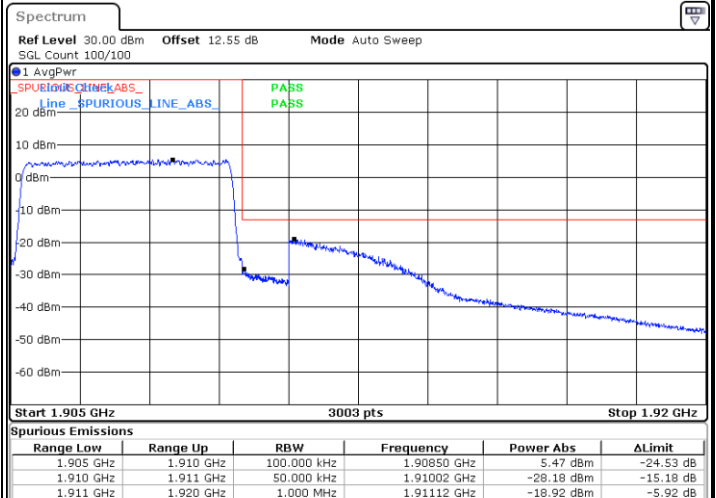



LTE Band 2 / 5MHz / 64QAM

Lowest Band Edge / Full RB

Highest Band Edge / Full RB

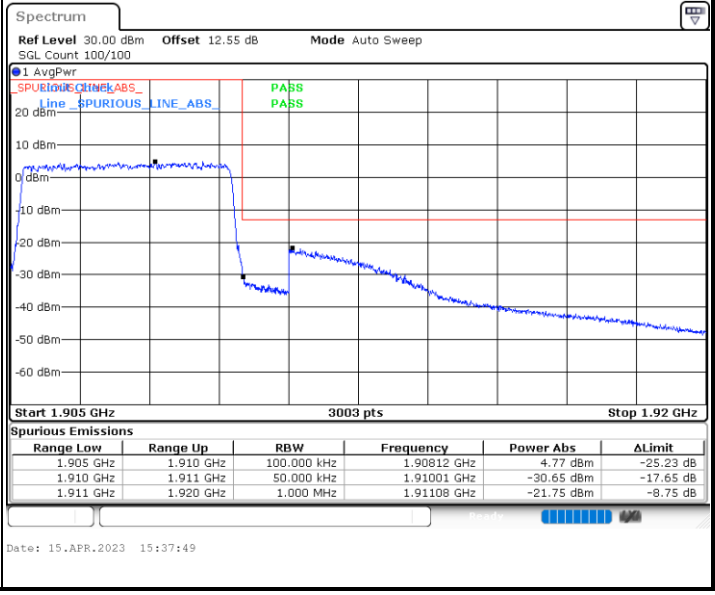
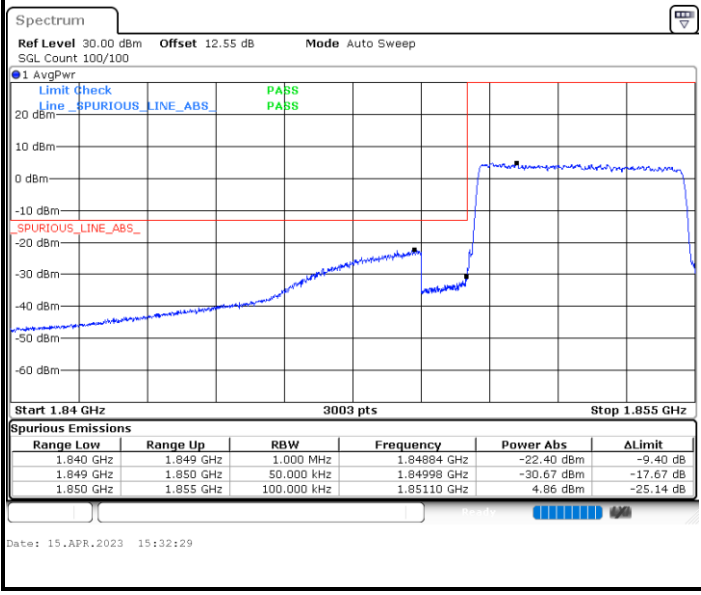



LTE Band 2 / 10MHz / QPSK

Lowest Band Edge / Full RB

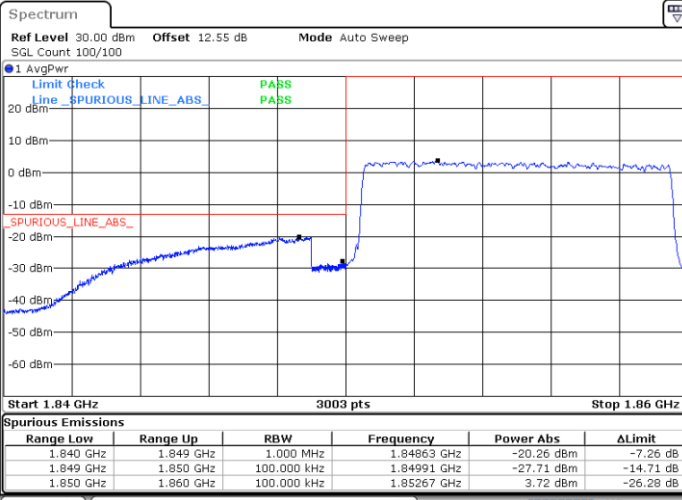

Date: 15.APR.2023 15:38:44

Highest Band Edge / Full RB

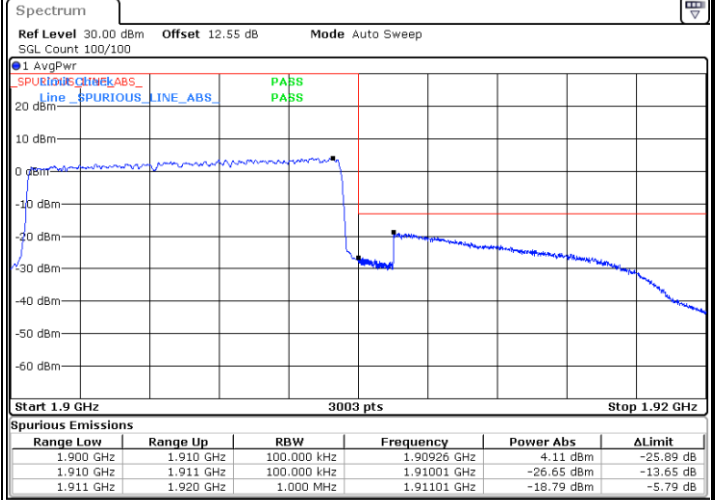

Date: 15.APR.2023 15:45:45

LTE Band 2 / 10MHz / 16QAM

Lowest Band Edge / Full RB

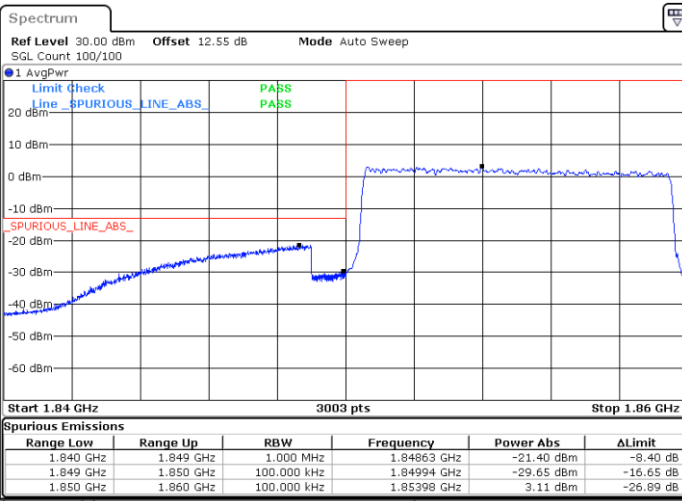

Date: 15.APR.2023 15:39:38

Highest Band Edge / Full RB

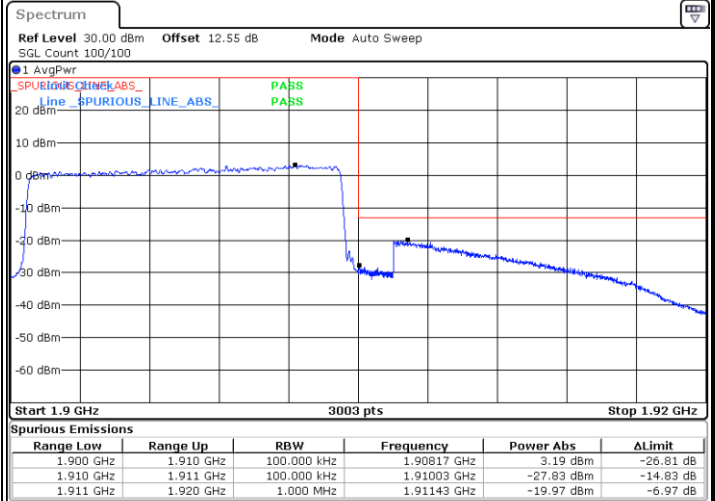

Date: 15.APR.2023 15:46:39



LTE Band 2 / 10MHz / 64QAM

Lowest Band Edge / Full RB

Highest Band Edge / Full RB

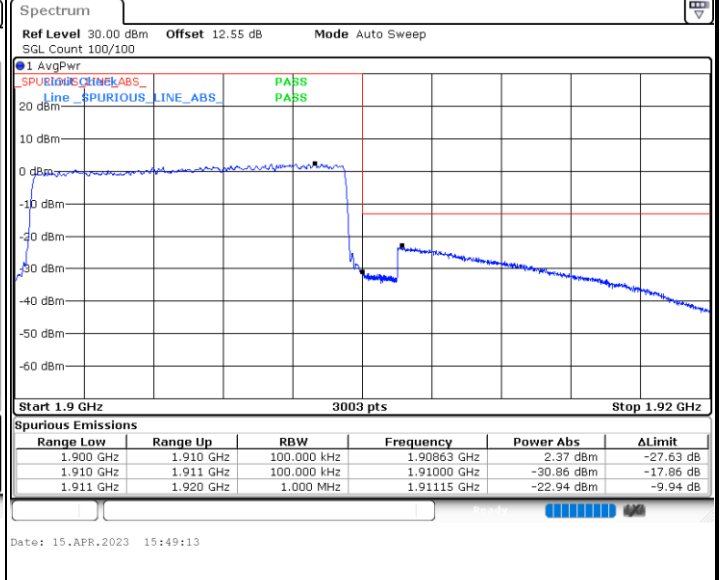
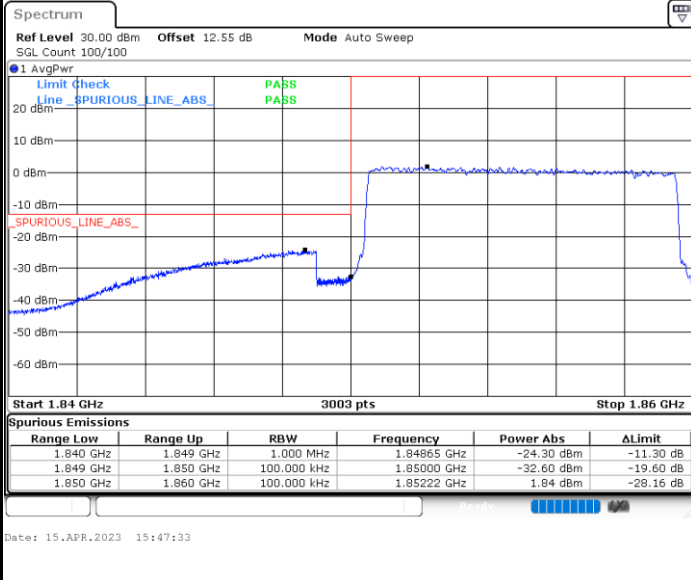



LTE Band 2 / 15MHz / QPSK

Lowest Band Edge / Full RB

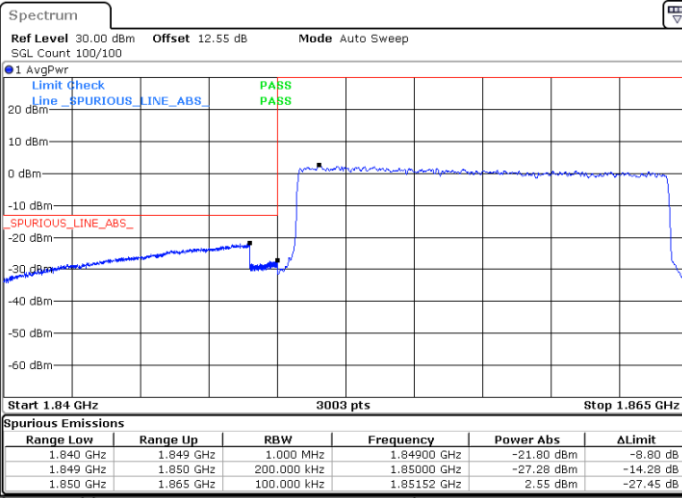

Date: 15.APR.2023 15:50:08

Highest Band Edge / Full RB

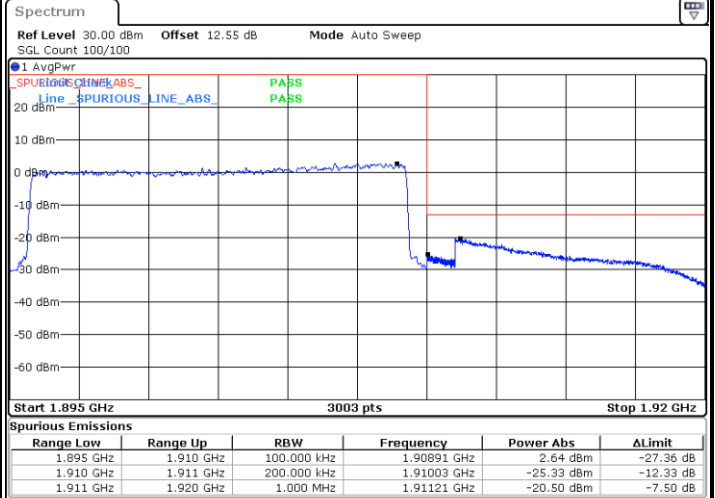

Date: 15.APR.2023 15:53:30

LTE Band 2 / 15MHz / 16QAM

Lowest Band Edge / Full RB

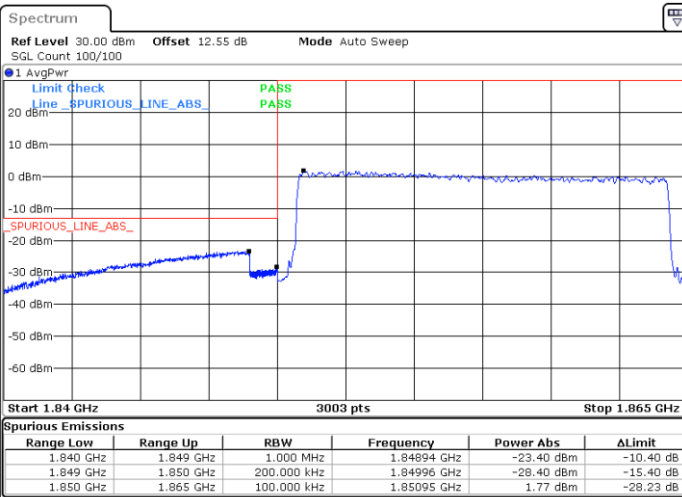

Date: 15.APR.2023 15:51:02

Highest Band Edge / Full RB

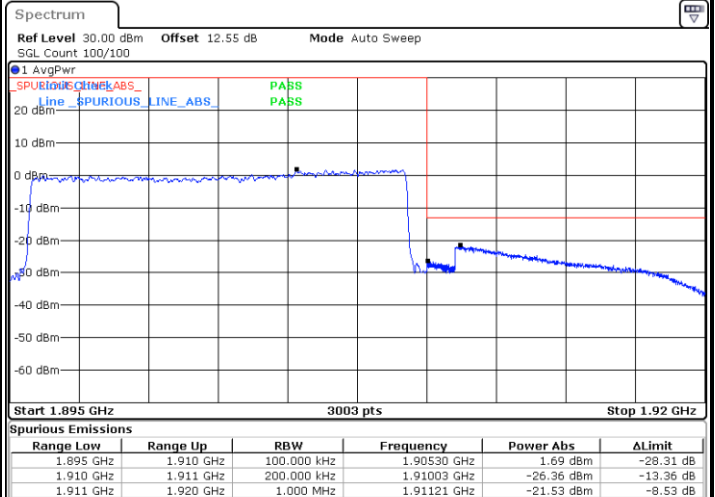

Date: 15.APR.2023 15:54:24



LTE Band 2 / 15MHz / 64QAM

Lowest Band Edge / Full RB

Highest Band Edge / Full RB

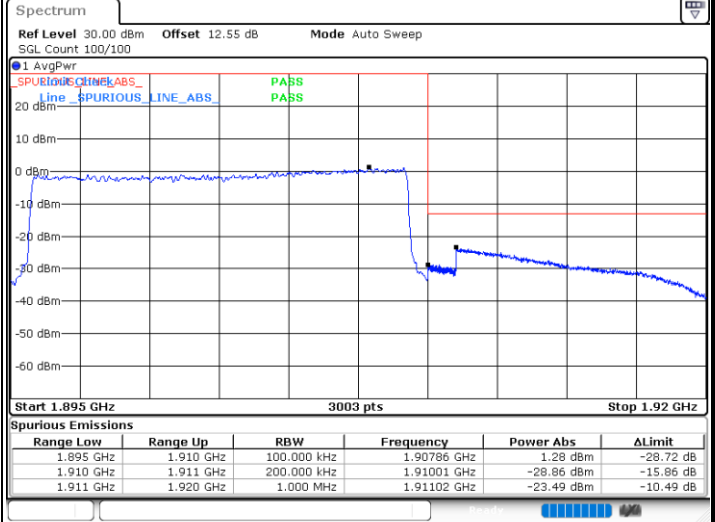
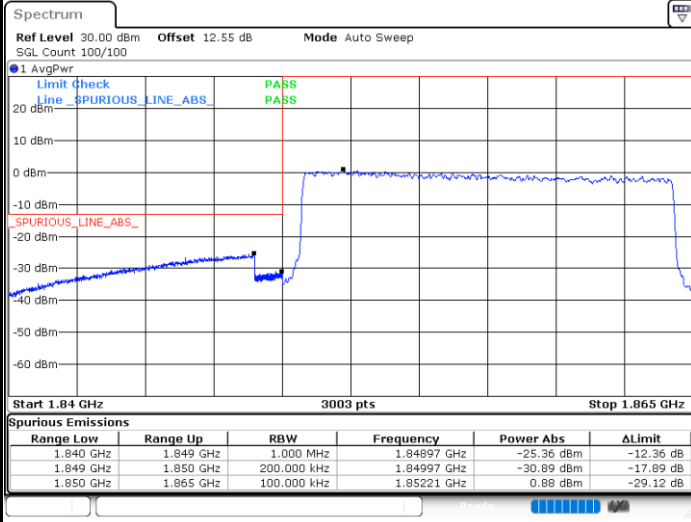

Date: 15.APR.2023 15:55:18

Date: 15.APR.2023 16:00:37



LTE Band 2 / 20MHz / QPSK

Lowest Band Edge / Full RB

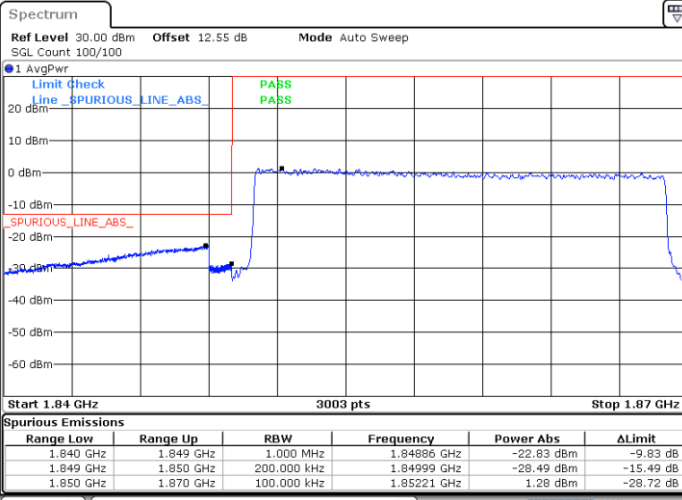

Date: 15.APR.2023 16:01:32

Highest Band Edge / Full RB

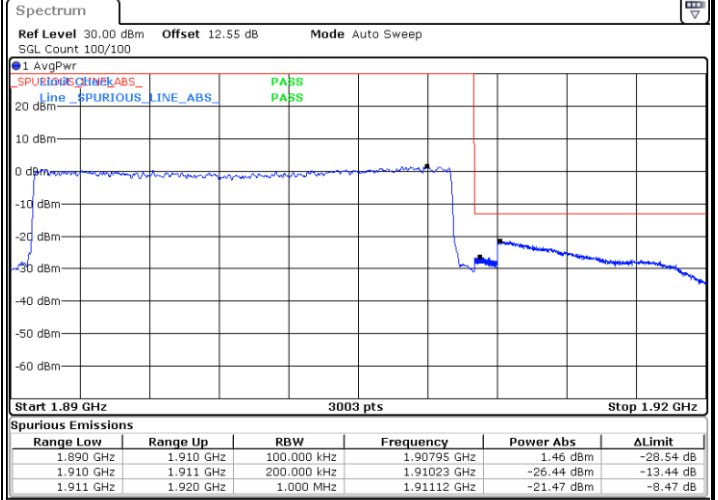

Date: 15.APR.2023 16:04:55

LTE Band 2 / 20MHz / 16QAM

Lowest Band Edge / Full RB

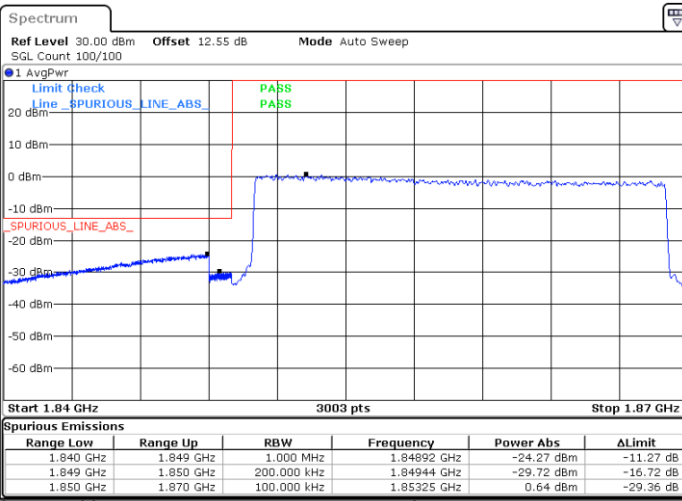

Date: 15.APR.2023 16:02:26

Highest Band Edge / Full RB

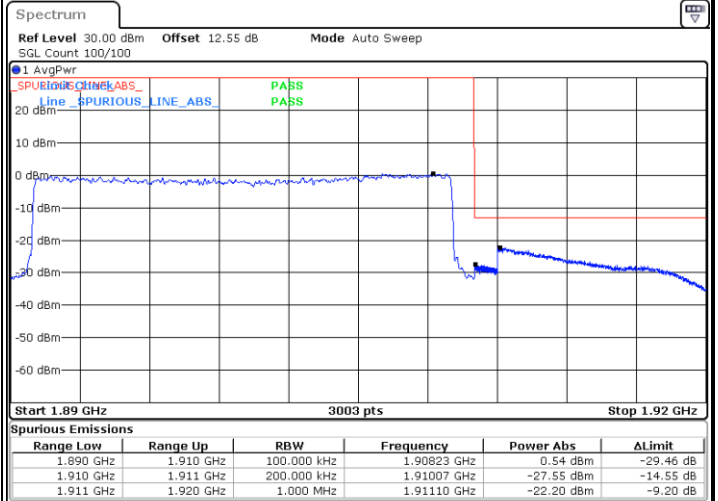

Date: 15.APR.2023 16:05:49



LTE Band 2 / 20MHz / 64QAM

Lowest Band Edge / Full RB

Highest Band Edge / Full RB

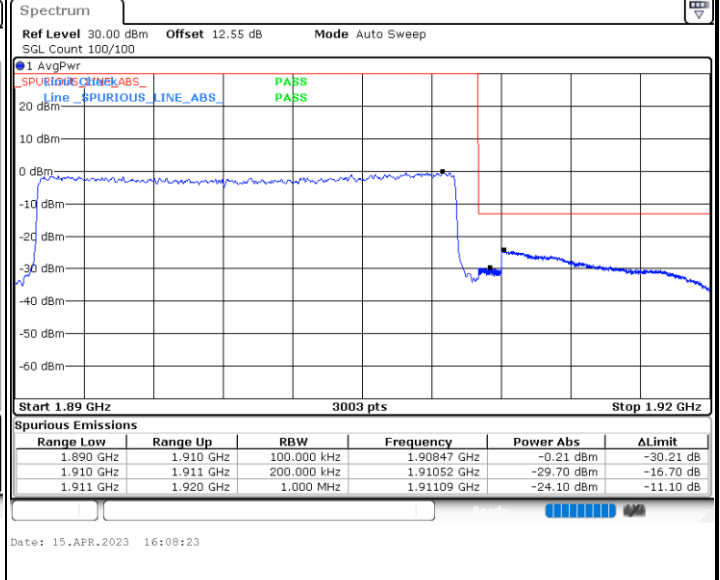
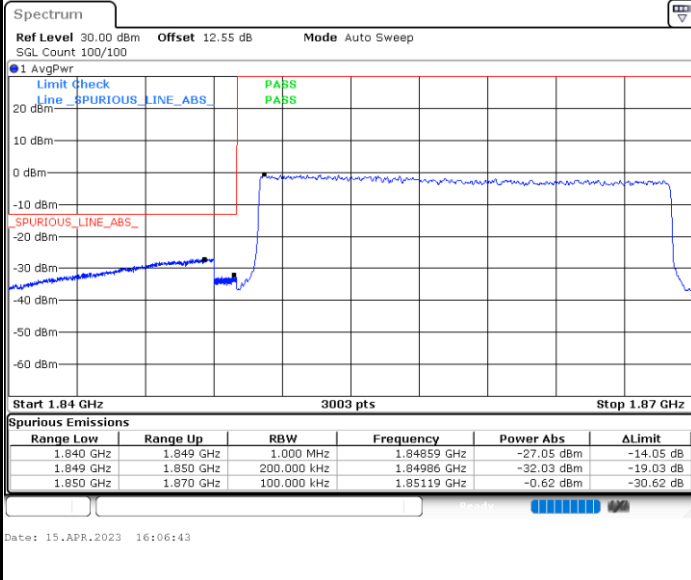



Conducted Spurious Emission

LTE Band 2 / 1.4MHz

Lowest Channel / QPSK

Middle Channel / QPSK

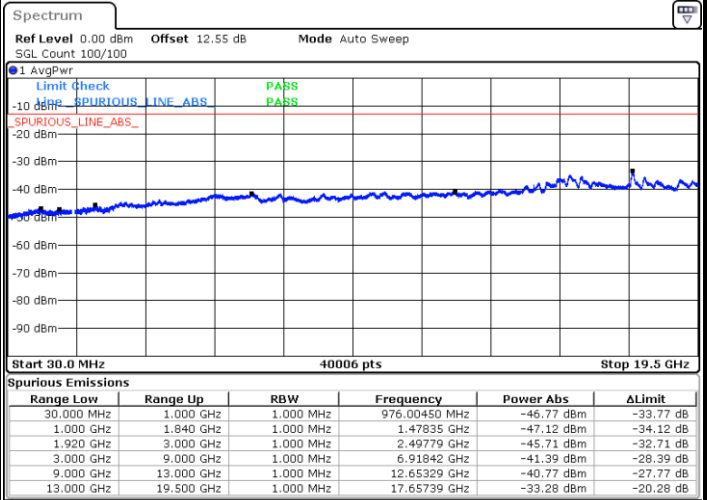
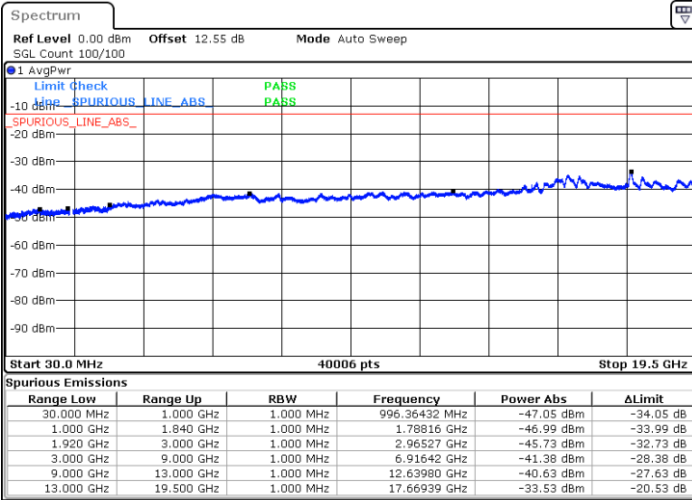

Date: 15.APR.2023 15:07:26

Date: 15.APR.2023 15:10:13

Highest Channel / QPSK

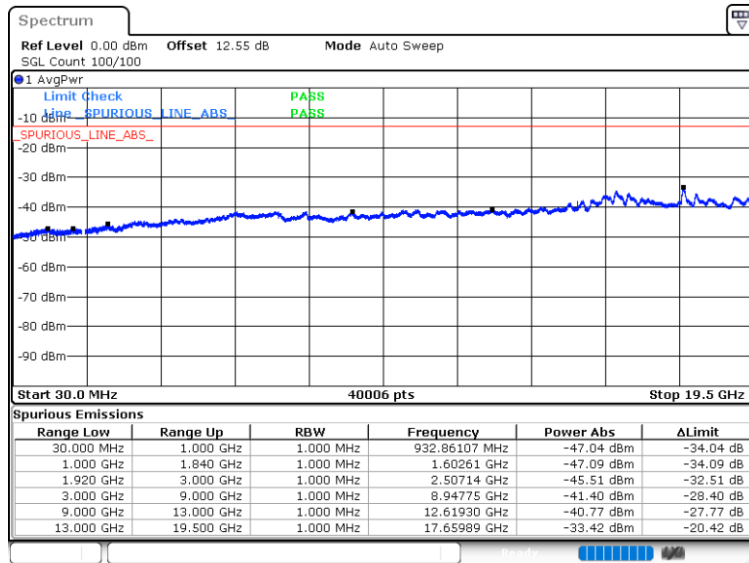

Date: 15.APR.2023 15:15:02



LTE Band 2 / 3MHz

Lowest Channel / QPSK

Middle Channel / QPSK

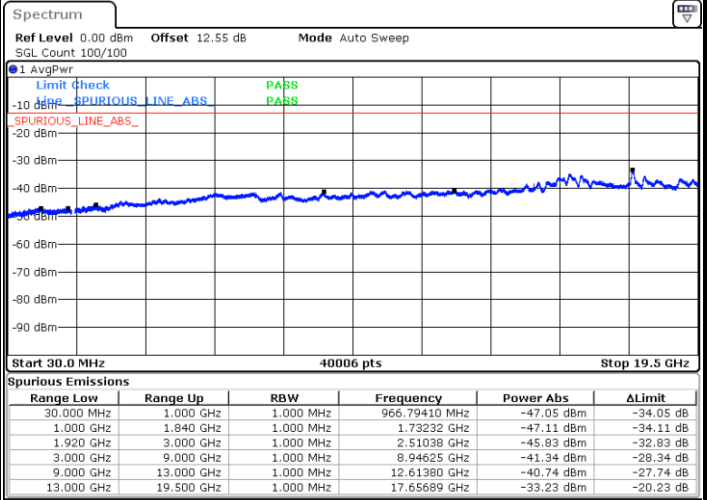
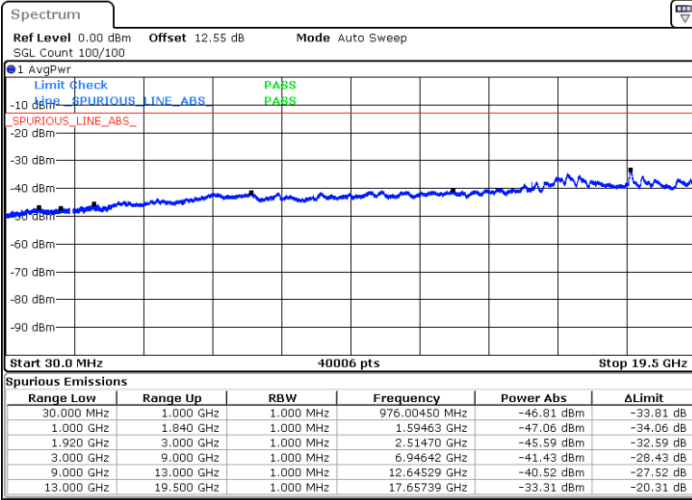

Date: 15.APR.2023 15:19:38

Date: 15.APR.2023 15:20:50

Highest Channel / QPSK

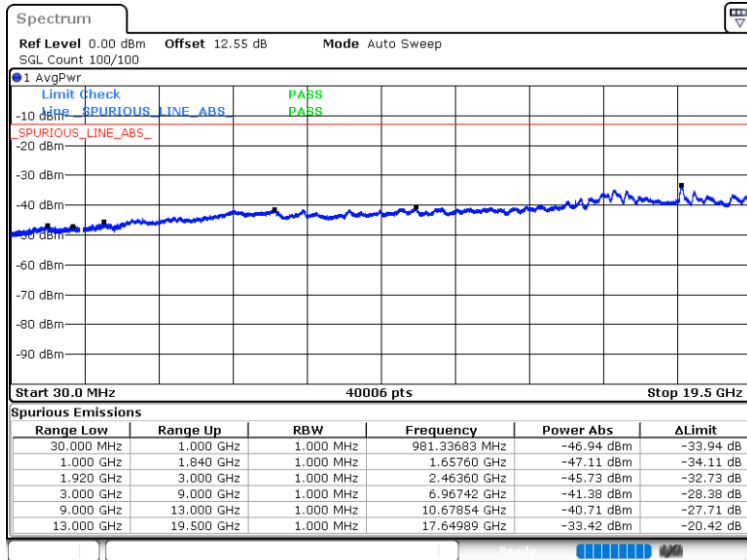

Date: 15.APR.2023 15:22:03