

TEST REPORT FOR NFC TESTING

Report No.: SRTC2023-9004(F)-23031502(N)

Product Name: Smart Phone

Product ID: APYHRO00324

Applicant: Sharp Corporation

Manufacturer: Sharp Corporation

Specification: CFR 47, Part 15, Sections 15.225, 15.207, 15.215

FCC ID: APYHRO00324

The State Radio_monitoring_center Testing Center (SRTC)

15th Building, No.30, Shixing Street, Shijingshan District, Beijing, P.R.China

Tel: 86-10-57996183 Fax: 86-10-57996388

CONTENTS

1. GENERAL INFORMATION	2
1.1 Notes of the test report	2
1.2 Information about the testing laboratory	2
1.3 Applicant's details	2
1.4 Manufacturer's details	2
1.5 Test Environment	3
2. DETAILS OF EQUIPMENT UNDER TEST	4
2.1 Final equipment builds status	4
2.2 Support equipment	4
3. REFERENCE SPECIFICATION	5
4. KEY TO NOTES AND RESULT CODES	5
5. RESULT SUMMARY	6
6. TEST RESULTS	7
6.1 Occupied Bandwidth	7
6.2 In-band emission	9
6.3 Radiated emission 9 kHz to 30 MHz	11
6.4 Radiated emission 30 MHz to 1 GHz	13
6.5 Carrier frequency stability	15
8. TEST EQUIPMENT	16
In-band emission	17
Radiated emission 9 kHz to 30 MHz and Radiated emission 30 MHz to 1 GHz	17

1. GENERAL INFORMATION

1.1 Notes of the test report

The test report may only be reproduced or published in full. Reproduction or publication of extracts from the report requires the prior written permission of The State Radio_monitoring_center Testing Center (SRTC).The test results relate only to individual items of the samples which have been tested. The certification and accreditation identifiers used in this report shall not be applicable to the tested or calibrated samples thereof. The manufacturer shall not mark the tested samples or items (or a separate part of the item) with the identifiers of certification and accreditation to mislead relevant parties about the tested samples or items.

1.2 Information about the testing laboratory

Company:	The State Radio_monitoring_center Testing Center (SRTC)
Test Site 1:	15th Building, No.30 Shixing Street, Shijingshan District
Test Site 2:	No.80, Zhaojiachang, Beizang, Daxing District
City:	Beijing
Country or Region:	P.R.China
Contacted person:	Liu Jia
Tel:	+86 10 57996183
Fax:	+86 10 57996388
Email:	liujiaf@srtc.org.cn
Designation Number:	CN1267
Registration number:	239125

1.3 Applicant's details

Company:	Sharp Corporation
Address:	1 Takumi-cho, Sakai-ku, Sakai City, Osaka 590-8522, Japan

1.4 Manufacturer's details

Company:	Sharp Corporation
Address:	1 Takumi-cho, Sakai-ku, Sakai City, Osaka 590-8522, Japan

1.5 Test Environment

Date of Receipt of test sample at SRTC:	2023-03-15
Testing Start Date:	2023-03-16
Testing End Date:	2023-04-10

Environmental Data:	Temperature (°C)	Humidity (%)
Ambient	25	40
Maximum Extreme	55	---
Minimum Extreme	-10	---

Normal Supply Voltage (V d.c.):	4.0
Maximum Extreme Supply Voltage (V d.c.):	4.0
Minimum Extreme Supply Voltage (V d.c.):	3.7

2. DETAILS OF EQUIPMENT UNDER TEST

2.1 Final equipment builds status

Operating Frequency	13.56 MHz
Antenna Type	PIFA
Modulation Type	ASK
Power Supply	Battery/DC supply
Software Revision:	NA
Hardware Revision:	PVT(Remodeled to the equivalent of MP products)

2.2 Support equipment

The following support equipment was used to exercise the EUT during testing: A

3. REFERENCE SPECIFICATION

Specification	Version	Title
2.202(a)	2021	Occupied bandwidth
15.225(a)-(c)	2021	In-band emission
15.225(d)	2021	Radiated emission 9 kHz to 30 MHz
15.205(b) 15.225(d)	2021	Radiated emission 30 MHz to 1 GHz
15.225(e)	2021	Carrier frequency stability
ANSI C63.10	2013	Standard of Procedures for Compliance Testing of Unlicensed Wireless Devices

4. KEY TO NOTES AND RESULT CODES

Code	Meaning
PASS	Test result shows that the requirements of the relevant specification have been met.
FAIL	Test result shows that the requirements of the relevant specification have not been met.
N/A	Test case is not applicable.
N/T	Test case is not tested.

5. RESULT SUMMARY

2	Item	Results
1	Occupied bandwidth	Pass
2	Conducted emission test	Pass
3	In-band emission	Pass
4	Radiated emission 9 kHz to 30 MHz	Pass
5	Radiated emission 30 MHz to 1 GHz	Pass
6	Carrier frequency stability	Pass

Test Site 2: No.80, Zhaojiachang, Beizang, Daxing District

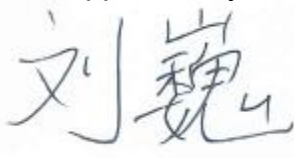
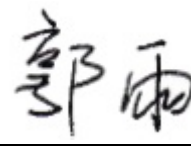
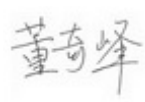
This Test Report Is Approved by: Mr. Liu Wei 	Review by: Mr. Guo Yu 
Tested and Issued by: Mr. Dong Qifeng 	Approved date: 20230508

6. TEST RESULTS

6.1 Occupied Bandwidth

6.1.1 Test conditions and test configuration

The occupied bandwidth according to CFR 47 Part 2, section 2.202(a), is measured as the 99% emission bandwidth, i.e. below its lower and above its upper frequency limits, the mean powers radiated are each equal to 0.5% of the total mean power radiated by a given emission.

The occupied bandwidth according to ANSI C63.10, section 6.9.1; is measured as the frequency range defined by the points that are 20 dB down relative to the maximum level of the modulated carrier.

The span range of the spectrum analyzer display shall be between two times and five times of the occupied bandwidth. The resolution bandwidth of the spectrum analyzer should be approximately 1% to 5% of the occupied bandwidth, unless otherwise specified, depending on the applicable requirement.

The video bandwidth shall be at least three times greater than the resolution bandwidth. The dynamic range of the spectrum analyzer at the selected resolution bandwidth shall be more than 10 dB below the target “dB down” (attenuation) requirement.

If antenna is detachable bandwidth measurements shall be performed at the antenna connector (conducted measurement) when the transmitter is adjusted in accordance with the tune-up procedure, if applicable. The RF output terminals are connected to a spectrum analyzer. If required, a resistive matching network equal to the impedance specified or employed for the antenna is used as well as dc block and appropriate attenuators (50 Ohms). The electrical characteristics of the radio frequency load attached to the output terminals shall be stated, if applicable. If radiated measurements are performed the same test setups and instruments are used as with radiated emission measurements for the appropriate frequency range.

The analyzer settings are specified by the test description of the appropriate test record(s).

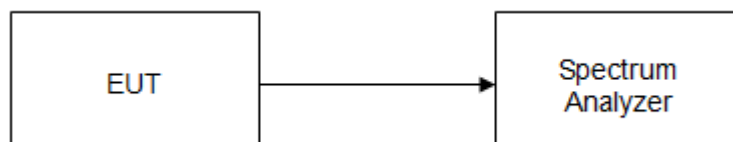

6.1.2 Test limit

The 20 dB bandwidth shall be specified in operating frequency band.

6.1.3 Test data

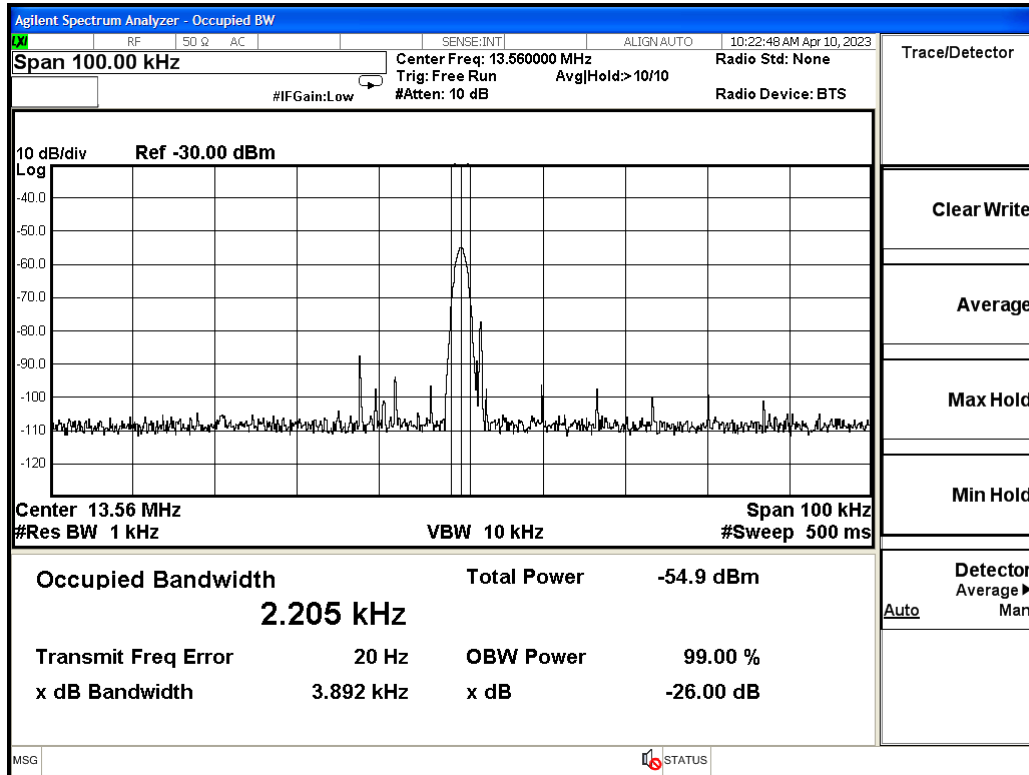

6.2 In-band emission

6.2.1 Test conditions and test configuration

In the case of a transmitter with an integral or dedicated antenna, the radiated H-field is defined in the direction of maximum field strength under specified conditions of measurement.

The measurements shall be made on an open field test site as specified in standard. Any measured values shall be at least 6 dB above the ambient noise level.

The H-field produced by the equipment shall be measured at standard distance of 3 m. Where this is not practical, e.g. due to physical size of the equipment including the antenna or with use of special field cancelling antenna, then other distances may be used. When another distance is used, the distance used and the field strength value measured shall be stated in the test report. In this case, the measured value at actual test distance shall be extrapolated to 3 m and stated in the test report.

The H-field is measured with a shielded loop antenna connected to a measurement receiver. The measuring bandwidth and detector type of the measurement receiver shall be in accordance with standard.

The equipment under test shall be operated with modulation as defined in standard.

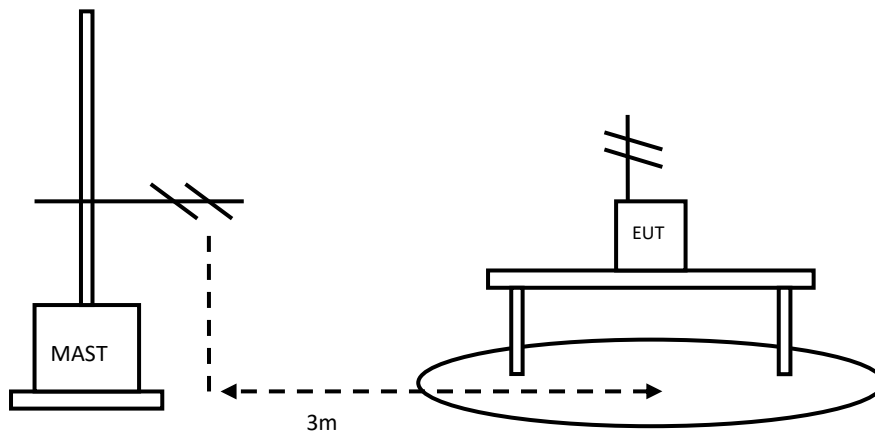

6.2.2 Test limit

- (a) The field strength of any emissions within the band 13.553-13.567 MHz shall not exceed 15,848 microvolts/meter at 30 meters.
- (b) Within the bands 13.410-13.553 MHz and 13.567-13.73 MHz, the field strength of any emissions shall not exceed 334 microvolts/meter at 30 meters.
- (c) Within the bands 13.110-13.43 MHz and 13.710-14.03 MHz the field strength of any emissions shall not exceed 106 microvolts/meter at 30 meters.

6.2.3 Test data

The test results are shown in Appendix A.

6.3 Radiated emission 9 kHz to 30 MHz

6.3.1 Test conditions and test configuration

The measurements shall be made on an open field test site as specified in standard. Any measured values shall be at least 6 dB above the ambient noise level.

The H-field produced by the equipment shall be measured at standard distance of 3 m. Where this is not practical, e.g. due to physical size of the equipment including the antenna or with use of special field cancelling antenna, then other distances may be used. When another distance is used, the distance used and the field strength value measured shall be stated in the test report. In this case, the measured value at actual test distance shall be extrapolated to 3 m and stated in the test report.

The H-field is measured with a shielded loop antenna connected to a measurement receiver. The measuring bandwidth and detector type of the measurement receiver shall be in accordance with standard.

The equipment under test shall be operated with modulation as defined in standard.

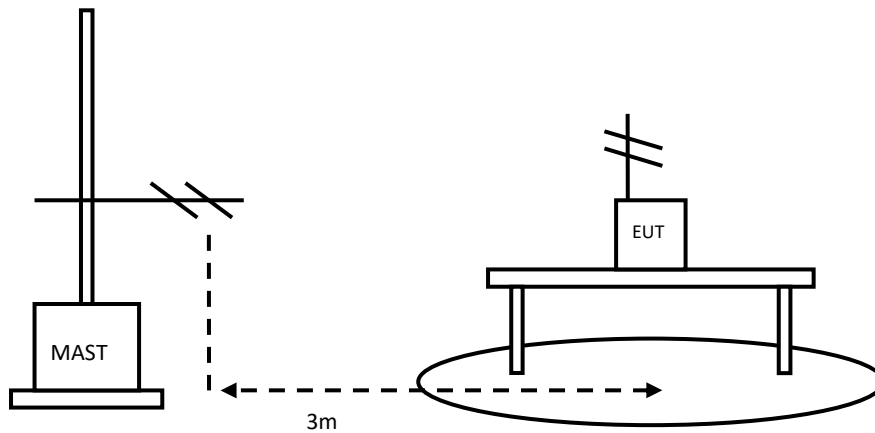

6.3.2 Test limit

(a) Except as provided elsewhere in this subpart, the emissions from an intentional radiator shall not exceed the field strength levels specified in the following table:

Frequency (MHz)	Field strength (microvolts/meter)	Measurement distance (meters)
0.009-0.490	2400/F(kHz)	300
0.490-1.705	24000/F(kHz)	30
1.705-30.0	30	30
30-88	100**	3
88-216	150**	3
216-960	200**	3
Above 960	500	3

**Except as provided in paragraph (g), fundamental emissions from intentional radiators operating under this section shall not be located in the frequency bands 54-72 MHz, 76-88 MHz, 174-216 MHz, or 470-806 MHz. However, operation within these frequency bands is permitted under other sections of this part, e.g., §§15.231 and 15.241.

6.3.3 Test data

The test results are shown in Appendix A.

6.4 Radiated emission 30 MHz to 1 GHz

6.4.1 Test conditions and test configuration

The measurements shall be made on an open field test site as specified in standard. Any measured values shall be at least 6 dB above the ambient noise level.

The H-field produced by the equipment shall be measured at standard distance of 3 m. Where this is not practical, e.g. due to physical size of the equipment including the antenna or with use of special field cancelling antenna, then other distances may be used. When another distance is used, the distance used and the field strength value measured shall be stated in the test report. In this case, the measured value at actual test distance shall be extrapolated to 3 m and stated in the test report.

The H-field is measured with a shielded loop antenna connected to a measurement receiver. The measuring bandwidth and detector type of the measurement receiver shall be in accordance with standard.

The equipment under test shall be operated with modulation as defined in standard.

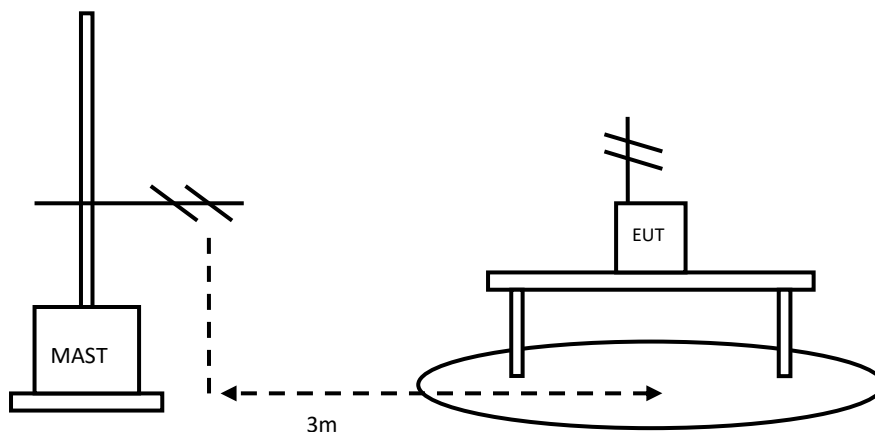

6.4.2 Test limit

(a) Except as provided elsewhere in this subpart, the emissions from an intentional radiator shall not exceed the field strength levels specified in the following table:

Frequency (MHz)	Field strength (microvolts/meter)	Measurement distance (meters)
0.009-0.490	2400/F(kHz)	300
0.490-1.705	24000/F(kHz)	30
1.705-30.0	30	30
30-88	100**	3
88-216	150**	3
216-960	200**	3
Above 960	500	3

**Except as provided in paragraph (g), fundamental emissions from intentional radiators operating under this section shall not be located in the frequency bands 54-72 MHz, 76-88 MHz, 174-216 MHz or 470-806 MHz. However, operation within these frequency bands is permitted under other sections of this part, e.g., §§15.231 and 15.241.

6.4.3 Test data

The test results are shown in Appendix A.

6.5 Carrier frequency stability

6.5.1 Test conditions and test configuration

(e) The frequency tolerance of the carrier signal shall be maintained within $\pm 0.01\%$ of the operating frequency over a temperature variation of -20 degrees to $+ 50$ degrees C at normal supply voltage, and for a variation in the primary supply voltage from 85% to 115% of the rated supply voltage at a temperature of 20 degrees C. For battery operated equipment, the equipment tests shall be performed using a new battery.

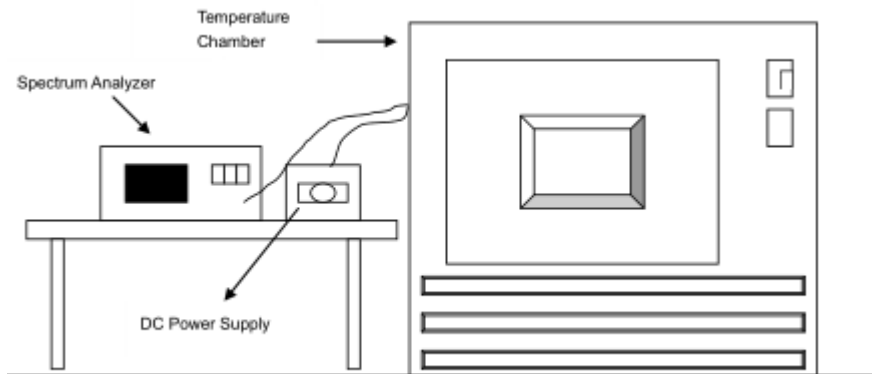

6.5.2 Test limit

$\pm 0.01\%$

6.5.3 Test data

Voltage(V)	Temperature($^{\circ}$ C)	Frequency (MHz)	Measured Frequency (MHz)	Frequency Stability (ppm)
4.0	50	13.56	13.560004	0.29
4.0	40	13.56	13.560002	0.15
4.0	30	13.56	13.560003	0.22
4.0	20	13.56	13.560001	0.07
4.0	10	13.56	13.560005	0.37
4.0	0	13.56	13.560006	0.44
4.0	-10	13.56	13.560003	0.22
4.0	-20	13.56	13.560004	0.29
4.0	-30	13.56	13.560002	0.15
3.7	20	13.56	13.560005	0.37

7. MEASUREMENT UNCERTAINTIES

Item	Uncertainty
Occupied Bandwidth	0.30 kHz
Carrier frequency stability	1×10^{-8}
Radiated Emission Measurements 9kHz~30MHz	4.88 dB
Radiated Emission Measurements 30MHz~1GHz	4.86 dB

Uncertainty figures are valid to a confidence level of 95%, k=2

8. TEST EQUIPMENT

No.	Name/ Model	Manufacturer	S/N	Cal date	Cal Due date
1.	Spectrum Analyzer / FSV	ROHDE & SCHWARZ	101065	2022.06.21	2023.06.20
2.	Fully-Anechoic Chamber / 12.65m×8.03m×7.50m	FRANKONIA	----	----	----
3.	Semi-Anechoic/Chamber / 23.18m×16.88m×9.60m	FRANKONIA	---	----	----
4.	Turn table Diameter:1m	FRANKONIA	----	----	----
5.	Turn table Diameter:5m	FRANKONIA	----	----	----
6.	Antenna master FAC(MA4.0)	MATURO	----	----	----
7.	Antenna master SAC(MA4.0)	MATURO	----	----	----
8.	Shielding room / 9.080m×5.255m×3.525m	FRANKONIA	----	----	----
9.	Double-Ridged Waveguide Horn Antenna / HF 907	R&S	100512	2022.06.21	2023.06.20
10.	Double-Ridged Waveguide Horn Antenna / HF 907	R&S	100513	2022.06.21	2023.06.20
11.	Ultra log antenna / HL562	R&S	100016	2022.06.21	2023.06.20
12.	Receive antenna /3160-09	SCHWARZ-BECK	002058-002	2022.06.21	2023.06.20
13.	EMI test receiver / ESI 40	R&S	100015	2022.06.21	2023.06.20
14.	EMI test receiver / ESCS30	R&S	100029	2022.06.21	2023.06.20
15.	Receive antenna / HL562	R&S	100167	2022.06.21	2023.06.20
16.	AMN / ENV216	R&S	3560.6550.12	2022.06.21	2023.06.20
17.	WLAN AP WIA3300-20	SKSpruce	8152017060700339	---	---
18.	Notebook E470c	Lenovo	PF10UZW7	---	---
19.	EMI test software / EMC32	R&S	V10.20.01	/	/

ANNEX A – Test Result

Radiated Emission Measurement

In-band emission

LoopAntennaat 3M

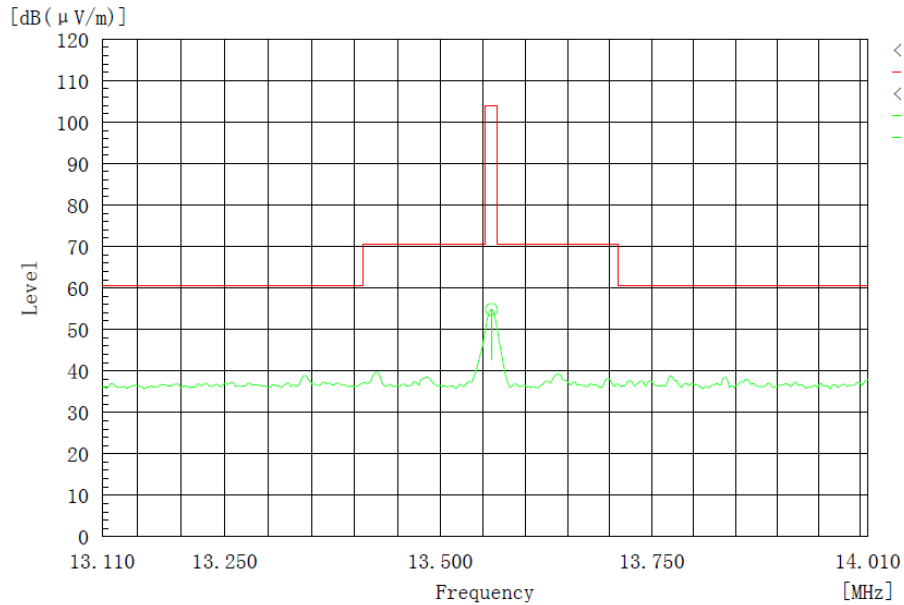

Frequency (MHz)	Max Peak (dBμV/m)	Limit (dBμV/m)	Margin (dB)	Bandwidth (KHz)	POL	Azimuth (deg)	Corr. (dB)	Comment
13.56000	54.8	104.0	49.2	9.000	V	0	20.0	

Radiated emission 9 kHz to 30 MHz and Radiated emission 30 MHz to 1 GHz

Frequency (MHz)	Result (dBuV/m)	ARpl (dB)	Pmea (dBuV/m)	Polarity	Limit (dBuV/m)
43.811	13.0	-21.5	34.5	Vertical	40.0
51.289	10.6	-21.1	31.7	Vertical	40.0
80.964	16.2	-27.6	43.8	Vertical	40.0
86.968	18.5	-25.8	44.3	Vertical	40.0
91.065	18.1	-24.2	42.3	Vertical	43.5

110.881	6.7	-22.8	29.5	Vertical	43.5
---------	-----	-------	------	----------	------

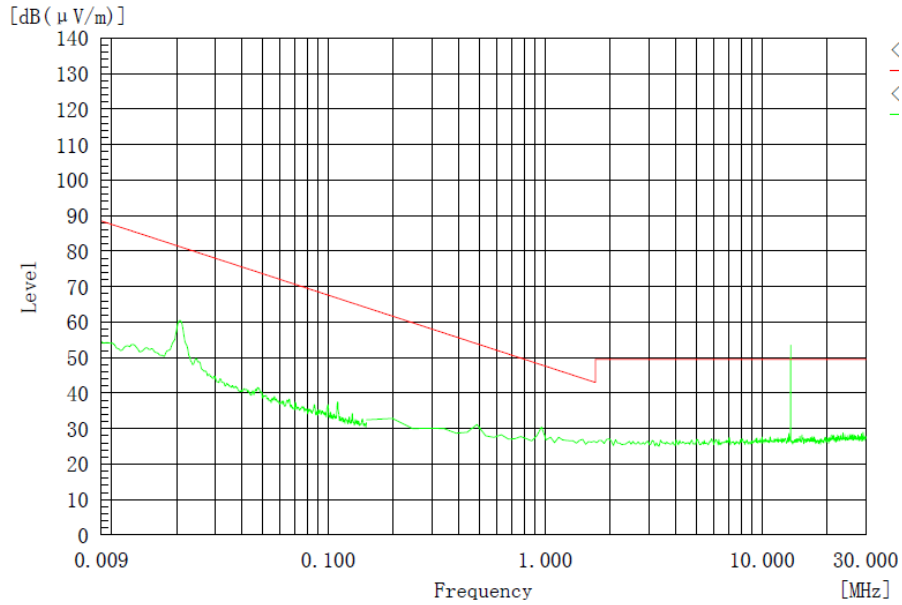

Frequency Range: 9kHz-30 MHz

Detector: QP mode

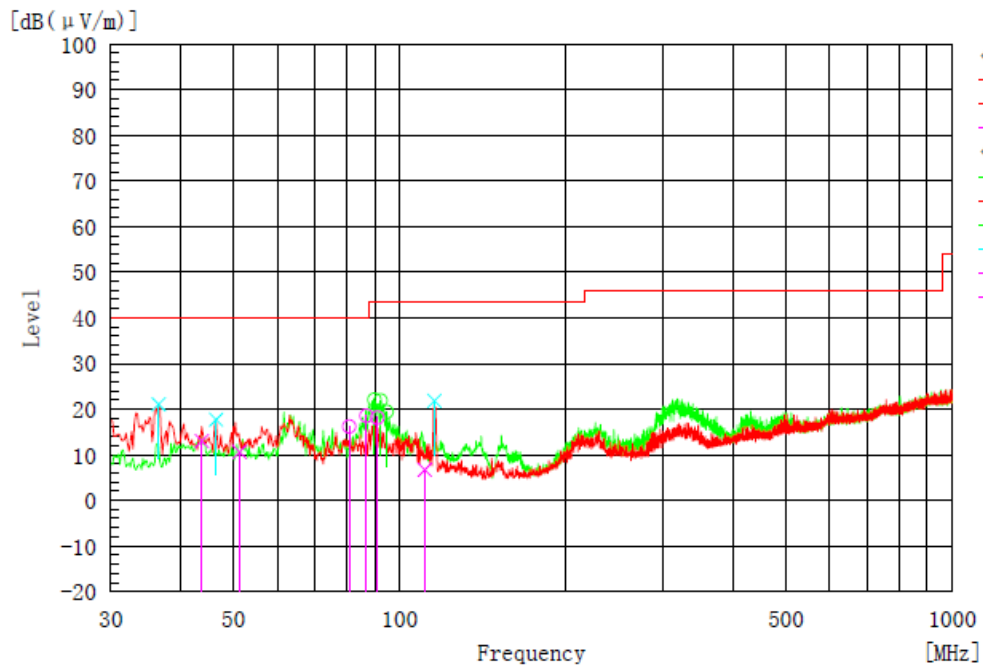

Frequency Range: 30MHz-1000 MHz

Detector: QP mode

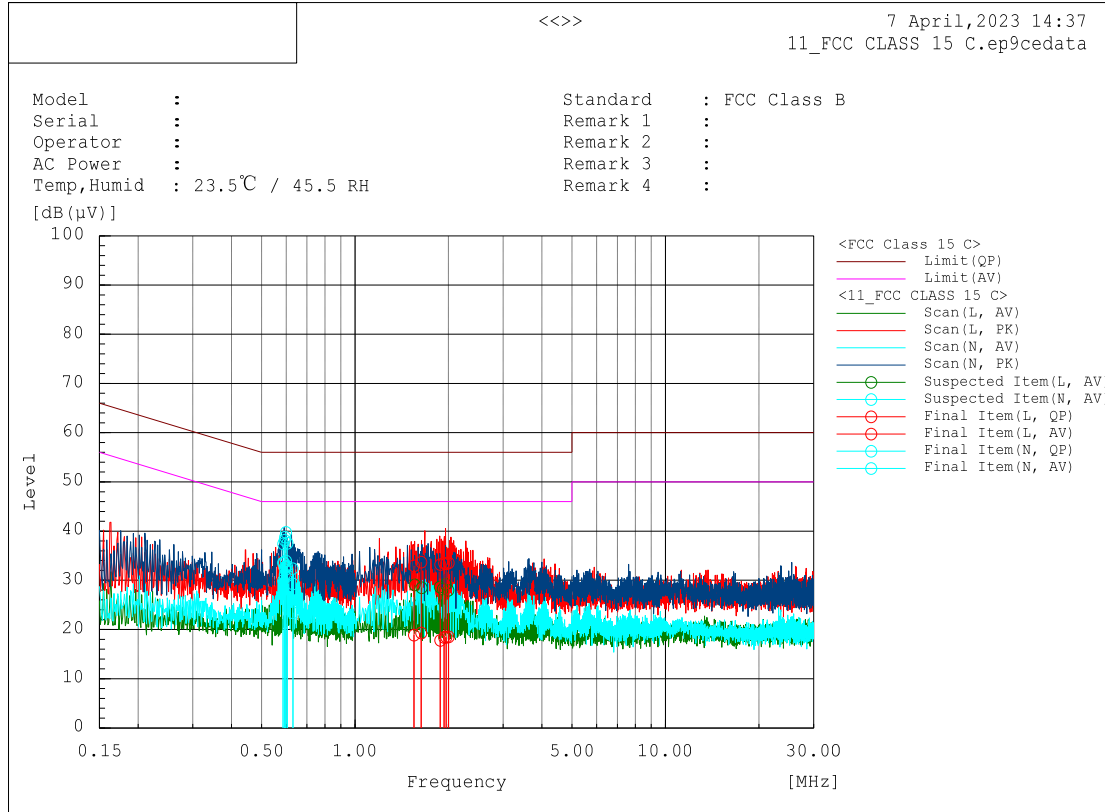

Final_Result

Range	Frequency MHz	Line	Reading			Factor dB	Level			Limit			Margin			Pass/Fail	Remark
			dB(μV)				dB(μV)			dB(μV)			dB				
			QP	AV	PK		QP	AV	PK	QP	AV	PK	QP	AV	PK		
Band1	1.548	L	13.1	-1		19.9	33	18.9		56	46		23	27.1		Pass	
Band1	1.634	L	13.8	-0.6		19.9	33.7	19.3		56	46		22.3	26.7		Pass	
Band1	1.883	L	13.3	-2.1		19.9	33.2	17.8		56	46		22.8	28.2		Pass	
Band1	1.934	L	13.6	-1.5		19.9	33.5	18.4		56	46		22.5	27.6		Pass	
Band1	1.967	L	13.5	-1.4		19.9	33.4	18.5		56	46		22.6	27.5		Pass	
Band1	2.002	L	13.7	-1.4		19.9	33.6	18.5		56	46		22.4	27.5		Pass	
Band1	0.587	N	17.5	10.1		19.9	37.4	30		56	46		18.6	16		Pass	
Band1	0.593	N	18.3	11.2		19.9	38.2	31.1		56	46		17.8	14.9		Pass	
Band1	0.595	N	18.9	12.3		19.9	38.8	32.2		56	46		17.2	13.8		Pass	
Band1	0.599	N	19.8	14		19.9	39.7	33.9		56	46		16.3	12.1		Pass	
Band1	0.605	N	17.6	11.1		19.9	37.5	31		56	46		18.5	15		Pass	
Band1	0.631	N	9.4	3.5		19.9	29.3	23.4		56	46		26.7	22.6		Pass	

---End of the test report---