

# TEST REPORT

---

Report No.: SRTC2023-9003(F)-0005  
Product Name: Smart Phone  
Model Name: APYHRO00324  
Applicant: Sharp Corporation  
Manufacturer: Sharp Corporation  
Specification: FCC Part15C (Certification)  
(2021 edition)

The State Radio\_monitoring\_center Testing Center (SRTC)  
15th Building, No.30 Shixing Street, Shijingshan District,  
Beijing, China

Tel: 86-10-57996183 Fax: 86-10-57996388

## CONTENTS

1. General information .....	3
1.1 Notes of the test report .....	3
1.2 Information about the testing laboratory .....	3
1.3 Applicant's details .....	3
1.4 Manufacturer's details .....	3
1.5 Application details .....	3
1.6 Reference specification .....	4
1.7 Information of EUT .....	4
1.7.1 General information .....	4
1.7.2 EUT details .....	4
1.7.3 Auxiliary equipment details .....	4
1.7.4 Operation Mode .....	5
2. Test information .....	6
2.1 Summary of the test results .....	6
2.2 Test result .....	7
2.2.1 Conducted Emissions-FCC Part15.207 .....	7
2.2.2 Radiated Emissions-FCC Part15.209 .....	11
2.2.3 20dB Bandwidth and 99% Bandwidth .....	17
2.3. List of test equipments .....	19
Appendix .....	20

## 1. General information

### 1.1 Notes of the test report

The test report may only be reproduced or published in full. Reproduction or publication of extracts from the report requires the prior written permission of The State Radio\_monitoring\_center Testing Center (SRTC).

The test results relate only to individual items of the samples which have been tested.

### 1.2 Information about the testing laboratory

Company: The State Radio\_monitoring\_center Testing Center (SRTC)  
Address: 15th Building, No.30 Shixing Street, Shijingshan District  
Testing location: No.80, Zhaojiachang, BeizangCun, Daxing District, Beijing, China.  
City: Beijing  
Country or Region: China  
Contacted person: Liu Jia  
Tel: +86 10 57996183  
Fax: +86 10 57996388  
Email: liujiaf@srtc.org.cn

### 1.3 Applicant's details

Company: Sharp Corporation  
Address: 1 Takumi-cho, Sakai-ku, Sakai City, Osaka 590-8522, Japan  
City: Osaka  
Country or Region: Japan  
Contacted person: Mr. Taihei Ohtsuka  
Tel: +81-50-5433-4157  
Email: ---

### 1.4 Manufacturer's details

Company: Sharp Corporation  
Address: 1 Takumi-cho, Sakai-ku, Sakai City, Osaka 590-8522, Japan  
City: Osaka  
Country or Region: Japan  
Contacted person: Mr. Taihei Ohtsuka  
Tel: +81-50-5433-4157  
Email: ---

### 1.5 Application details

Date of reception of test sample: 24<sup>th</sup> Mar. 2023

Date of test: 24<sup>th</sup> Mar. 2023 to 3<sup>th</sup> Apr. 2023

## 1.6 Reference specification

FCC Part 15C 2021 (Certification)

## 1.7 Information of EUT

### 1.7.1 General information

Model Name of EUT	APYHRO00324
Operating Frequency range	Charging stand: 110-148kHz
Test condition of declaration	Normal
Telecommunication center	<input type="checkbox"/> Yes <input checked="" type="checkbox"/> No
S/N	/
HW Version	PVT(Remodeled to the equivalent of MP products)
SW Version	/

### 1.7.2 EUT details

Internal Control Number	Model	SN
EUT1	APYHRO00324	/

### 1.7.3 Auxiliary equipment details

AE (Auxiliary Equipment) 1#: Wireless Charging

Manufacturer	ELECOM
Model Number	W-QA02BK
Input Voltage	5V/2A
Output Voltage	---

AE (Auxiliary Equipment) 2#: Battery

Manufacturer	Murata Energy Device Wuxi Co., Ltd.
Model Number	UBATIA311AFN1
Battery Capacity	4870mAh

---

AE (Auxiliary Equipment) 3#: ADAPTER

Manufacturer	ELECOM
Model Number	NY-PW0F3-05002400
Input Voltage	100-240VAC,50Hz/60Hz 0.4A
Output Voltage	5VDC,2.4A



**1.7.4 Operation Mode**

Test has performed with the Charging base combined with the EUT under its battery power more than 90% energy. So all the test performed when the EUT working with battery power is more than 90%.

## 2. Test information

### 2.1 Summary of the test results

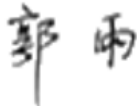
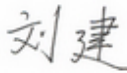
No.	Test case	Verdict
1	Conducted emissions	Pass
2	Radiated emissions	Pass
3	20dB Bandwidth and 99% Bandwidth	Pass

Approved By: Mr. Guo Yu Vice director of the test department 	Checked By: Mr. Liu Jian 
Tested by: Mr. Wen Jianlong Test engineer 	Issued date: 2023.4.17

## 2.2 Test result

### 2.2.1 Conducted Emissions-FCC Part15.207

Ambient condition:

Temperature	Relative humidity	Pressure
24.2°C	38.3%	100.8kPa

Test Setup with charger:

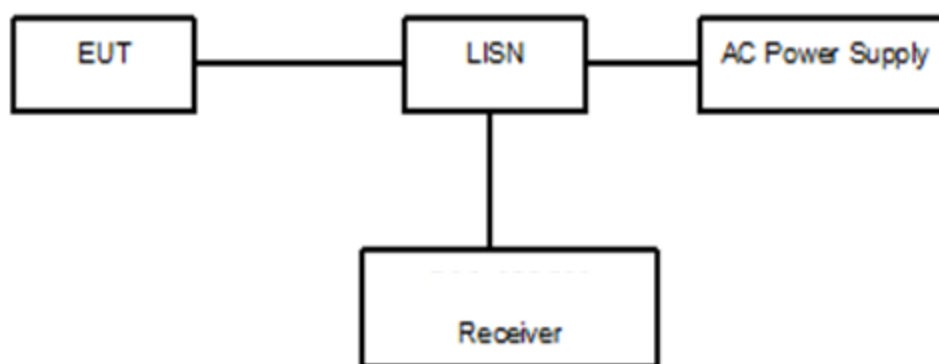

Figure 1

Test Procedure:

The EUT is placed on a non-metallic table 0.8m above the horizontal metal reference ground plane. The EUT is connected with LISN via the charger and Charging base. The LISN is connected to the reference ground. Open the following functions of EUT: Alarm clock.

The test set-up and the test methods are performed according to ANSI C63.10:2013.

Then start the test software EMC32. Sweep the whole frequency band through the range from 150 KHz to 30 MHz with RBW 9kHz, VBW 30kHz. The measurement should be done for both L line and N line. During pre-test, the receiver uses both peak detector and average detector. And the final test, the receiver uses both average detector and Quasi-peak detector.

A "reference path loss" Corr.(dB) is established and the  $L_{cable+ATT+VDF}$  is the attenuation of "reference path loss", and including the cable loss, the attenuation of the attenuator, the voltage division factor of AMN.

The measurement results are obtained as described below:

$$P_{result} = P_{mea} + Corr.(dB)$$

Sample calculation:  $(38.76 \text{ dB}\mu\text{V}) = (8.96 \text{ dB}\mu\text{V}) + (29.8 \text{ dB})$ , the corresponding frequency is 0.33763MHz.

Frequency (MHz)	Quasi Peak (dBμV)	Average (dBμV)	Limit (dBμV)	Margin (dB)	Line	Corr (dB)	P <sub>mea</sub> Quasi Peak (dBμV)	P <sub>mea</sub> Average (dBμV)
0.33763	38.76	---	59.26	20.5	L1	29.8	8.96	---

Limit:

Frequency of Emission(MHz)	Limits(dBμV)	
	Quasi-peak	Average
0.15~0.5	66 to 56*	56 to 46*
0.5~5	56	46
5~30	60	50

Note: \* Decreases with the logarithm of the frequency

Test result:

### Noise Level of the Measuring Instrument

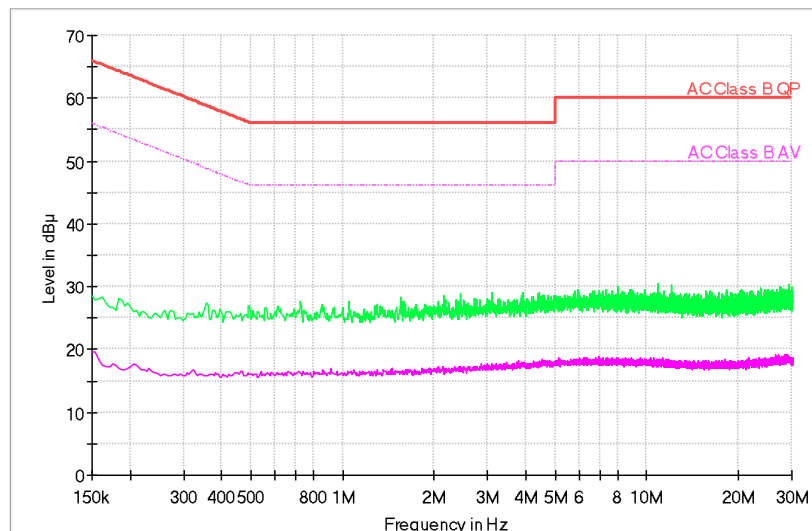

Preview Result 2-AVG      Preview Result 1-PK+  
ACClass B QP              ACClass B AV

Comment

Pic1.Conducted emission L and N Line



EUT + AE#1: Wireless Charging +AE #2: Battery +AE #3: ADAPTER:

Full Spectrum

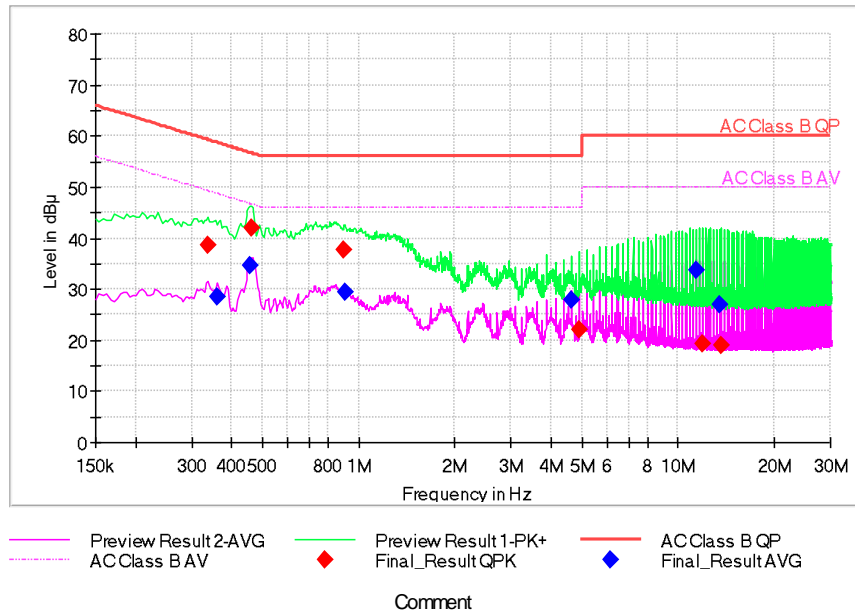

Pic2. Conducted emission L&N Line Voltage: 120VAC

Frequency (MHz)	Quasi Peak (dBμV)	Average (dBμV)	Limit (dBμV)	Margin (dB)	Line	Corr (dB)	P <sub>mea</sub> Quasi Peak (dBμV)	P <sub>mea</sub> Average (dBμV)
0.33763	38.76	---	59.26	20.5	L1	29.8	8.96	---
0.35895	---	28.64	48.75	20.11	L1	29.8	---	-1.16
0.45703	---	34.76	46.75	11.98	L1	29.8	---	4.96
0.46129	41.92	---	56.67	14.75	L1	29.8	12.12	---
0.90051	37.55	---	56	18.45	N	29.8	7.75	---
0.90478	---	29.43	46	16.57	L1	29.8	---	-0.37
4.65309	---	28	46	18	L1	29.8	---	-1.8
4.90894	22.03	---	56	33.97	L1	29.8	-7.77	---
11.3779	---	33.8	50	16.2	L1	29.9	---	3.9
11.8896	19.21	---	60	40.79	L1	29.9	-10.69	---
13.4418	---	27.03	50	22.97	L1	29.9	---	-2.87
13.7019	18.98	---	60	41.02	L1	29.9	-10.92	---

EUT + AE#1: Wireless Charging +AE #2: Battery +AE #3: ADAPTER:

Full Spectrum

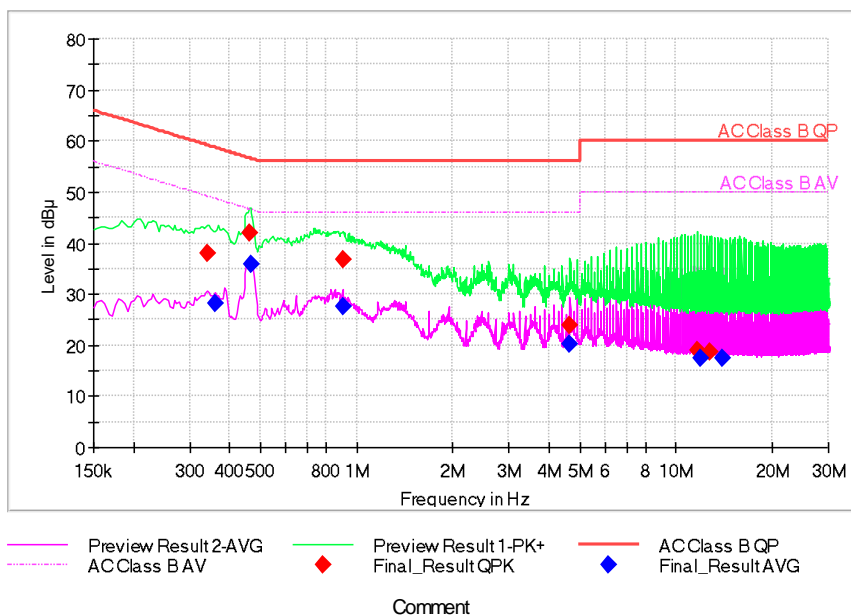

Pic3. Conducted emission L&N Line Voltage: 240VAC

Frequency (MHz)	Quasi Peak (dBµV)	Average (dBµV)	Limit (dBµV)	Margin (dB)	Line	Corr (dB)	P <sub>mea</sub> Quasi Peak (dBµV)	P <sub>mea</sub> Average (dBµV)
0.34189	37.99	---	59.16	21.16	L1	29.8	8.19	---
0.35895	---	28.2	48.75	20.55	L1	29.8	---	-1.6
0.46129	41.96	---	56.67	14.71	L1	29.8	12.16	---
0.46556	---	35.78	46.59	10.81	L1	29.8	---	5.98
0.90478	---	27.49	46	18.51	L1	29.8	---	-2.31
0.90478	36.64	---	56	19.36	L1	29.8	6.84	---
4.66161	24.05	---	56	31.95	L1	29.8	-5.75	---
4.66161	---	20.2	46	25.8	L1	29.8	---	-9.6
11.655	18.9	---	60	41.1	L1	29.9	-11	---
11.9152	---	17.57	50	32.43	L1	29.9	---	-12.33
12.6955	18.83	---	60	41.17	L1	29.9	-11.07	---
13.9876	---	17.46	50	32.54	L1	29.9	---	-12.44

## 2.2.2 Radiated Emissions-FCC Part15.209

Ambient condition:

Temperature	Relative humidity	Pressure
24.2°C	38.3%	100.8kPa

Test Setup:

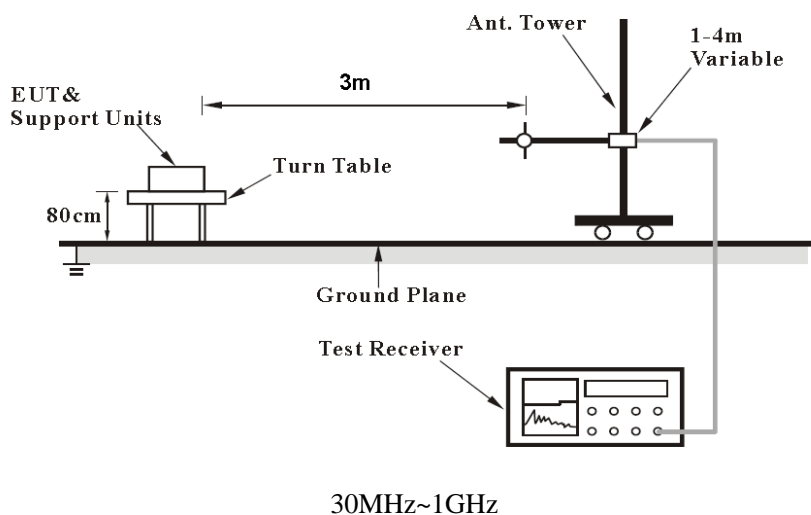
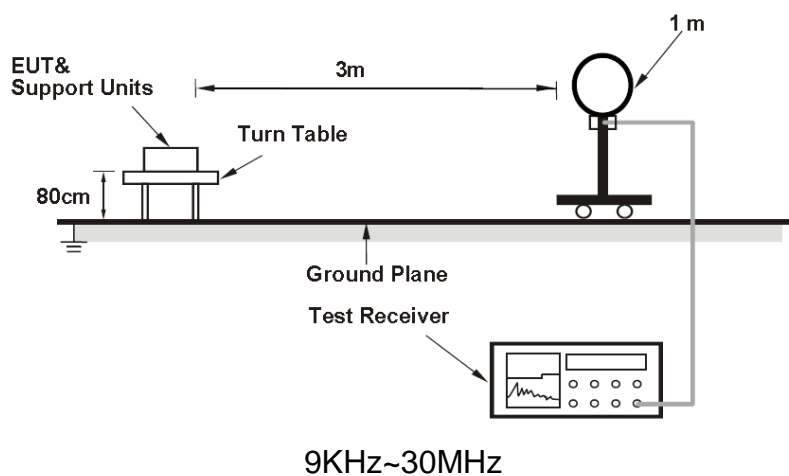

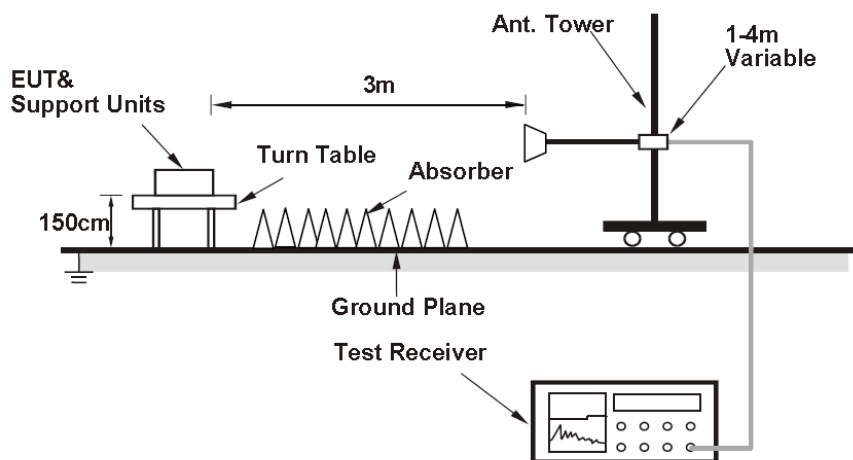

Above 1GHz

Figure 2

#### Test Procedure:

The EUT should be placed on a non-metallic table 80cm above the ground plane. The receive antennas shall be moved from 1 to 4 meters above 30MHz. The distance between EUT and receive antenna should be 3 meters.

The EUT should work in charging mode. The test set-up and the test methods are performed according to ANSI C63.10:2013..

Then start the test software EMC32. Sweep the whole frequency band through the range from 9KHz to 30MHz, using receive log period antenna HFH2-Z2. The lowest height of the magnetic antenna shall be 1 m above the ground. Measurement is made aligning the loop antenna along the site axis, orthogonal to the axis (x,y,z), when perpendicular to the ground plane. Sweep the whole frequency band through the range from 30MHz to 1GHz, using receive log period antenna VULB 9163.

During the test, the height of receive antenna shall be moved from 1 to 4 meters, and the antenna shall be performed under horizontal and vertical polarization. The turn table shall be rotated from 0 to 360 degrees for detecting the maximum of radiated spurious signal level. The measurements shall be repeated with orthogonal polarization of the test antenna. The EUT is laid in two modes as follow:  
1. put the EUT in horizontal direction; 2. put the EUT in vertical direction.

The data of cable loss and antenna factor have been calibrated in full testing frequency range before the testing. All test results are performed with max hold at the horizontal and vertical polarity.

RBW=120kHz, VBW=300kHz, when the test frequency:  $30\text{MHz} < f < 1\text{GHz}$

RBW=1MHz, VBW=3MHz, when the test frequency:  $f > 1\text{GHz}$

A "reference path loss" is established and the  $A_{Rpl}$  is the attenuation of "reference path loss", and including the gain of receive antenna, the gain of the preamplifier, the cable loss.

The measurement results are obtained as described below:

$$\text{Result} = P_{\text{mea}} + A_{\text{Rpl}}$$

Sample calculation:  $(19.75\text{dB}\mu\text{V}/\text{m}) = (37.85\text{dB}\mu\text{V}) + (-18.1\text{dB}/\text{m})$ , the corresponding frequency is 46.878MHz.

Frequency (MHz)	Result (dBuV/m)	Limit (dBuV/m)	ARpl (dB/m)	Pmea (dBuV)	Polarity	Margin (dB)
46.878	19.75	40.00	-18.1	37.85	V	20.25

Limit:

Frequency (MHz)	Field strength (uV/m)	Measurement distance (meters)
0.009-0.490	2400/F(kHz)	300
0.490-1.705	24000/F(kHz)	30
1.705-30.0	30	30
30-88	100	3
88-216	150	3
216-960	200	3
Above 960	500	3

The Detector and RBW/VBW Setting:

Frequency(MHz)	Detector	RBW	VBW
0.009-0.15	Average	200Hz	1KHz
0.15-0.49	Average	9KHz	30KHz
0.49-30	Quasi-peak	9KHz	30KHz
30-1000	Quasi-peak	100KHz	300KHz
1000-6000	Peak and Average	1MHz	3MHz

30-1000MHz

Frequency (MHz)	Result (dBuV/m)	Limit (dBuV/m)	ARpl (dB/m)	Pmea (dBuV)	Polarity	Margin (dB)
46.878	19.75	40.00	-18.1	37.85	V	20.25
75.3475	6.08	40.00	-23.2	29.28	V	33.92
141.7925	15.5	43.50	-22.6	38.1	V	28.00
272.5485	6.56	46.00	-16.6	23.16	V	39.44
522.0325	13.56	46.00	-10.3	23.86	V	32.44
899.314	19.06	46.00	-3.2	22.26	V	26.94

Full Spectrum

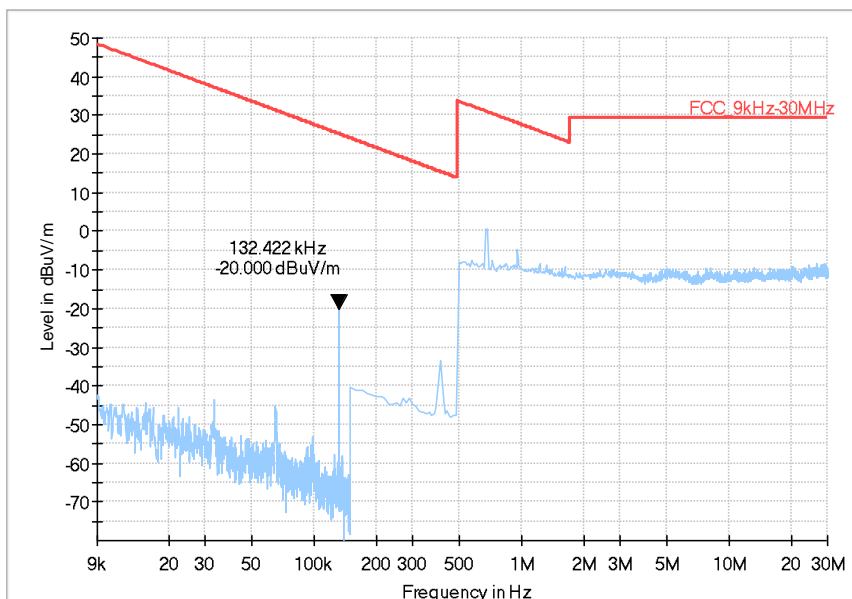

Pic4. Radiated emission(9KHz – 30MHz)

Note: Loop antenna at 3M, the test result has extrapolated to the specified distance which standard required.

Full Spectrum

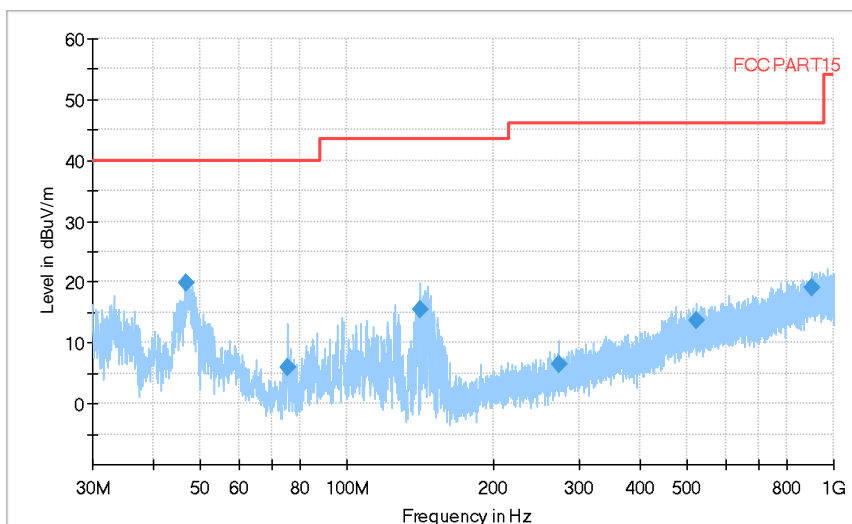

Preview Result 1-PK+    FCC PART 15    Final\_Result QPK

Comment

Pic5. Radiated emission(30MHz – 1GHz)

Note: The test data in the graph includes two polarizations: horizontal and vertical

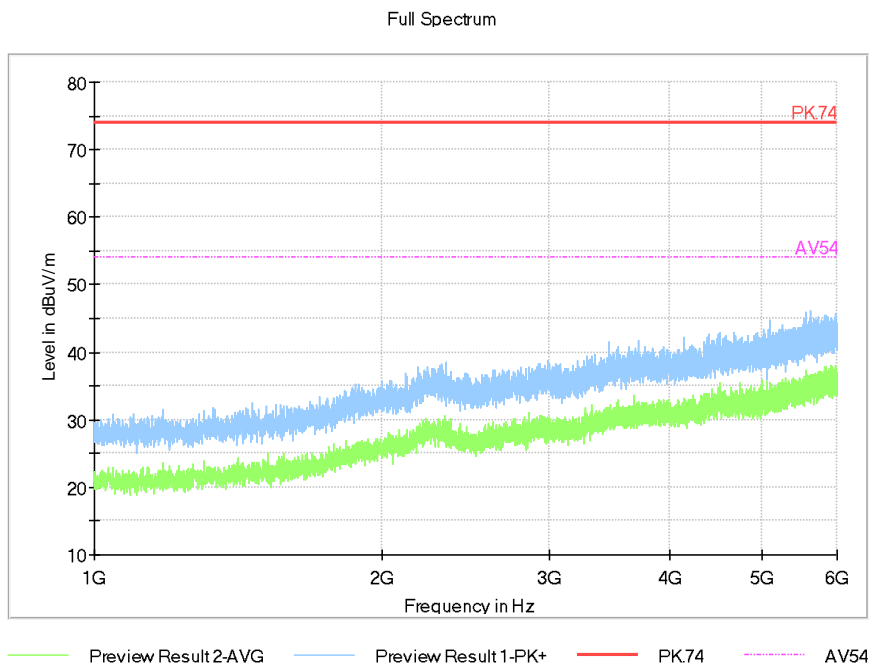

Pic6. Radiated emission (1GHz – 6GHz)

Note: The test data in the graph includes two polarizations: horizontal and vertical

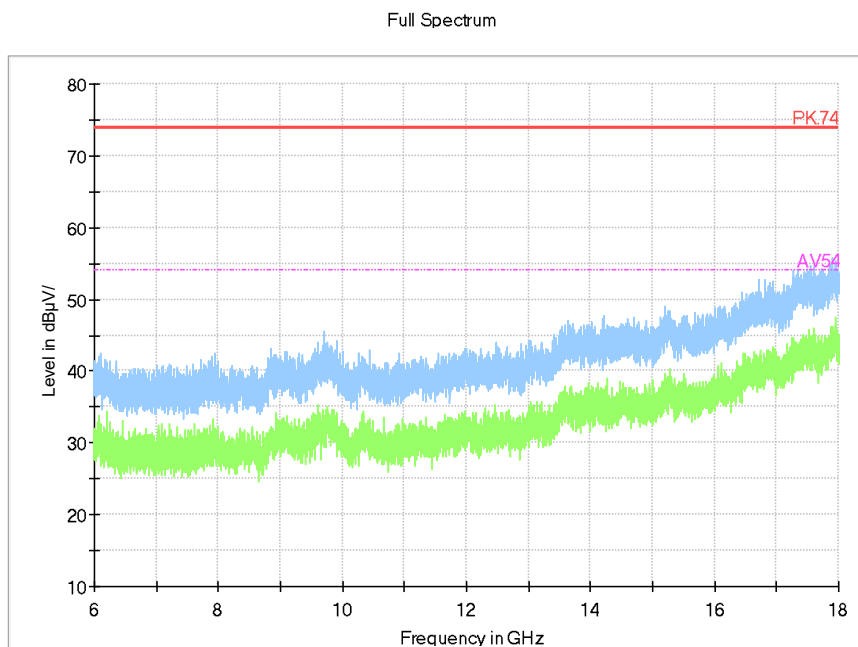

Pic7. Radiated emission (6GHz – 18GHz)

Note: The test data in the graph includes two polarizations: horizontal and vertical

Full Spectrum

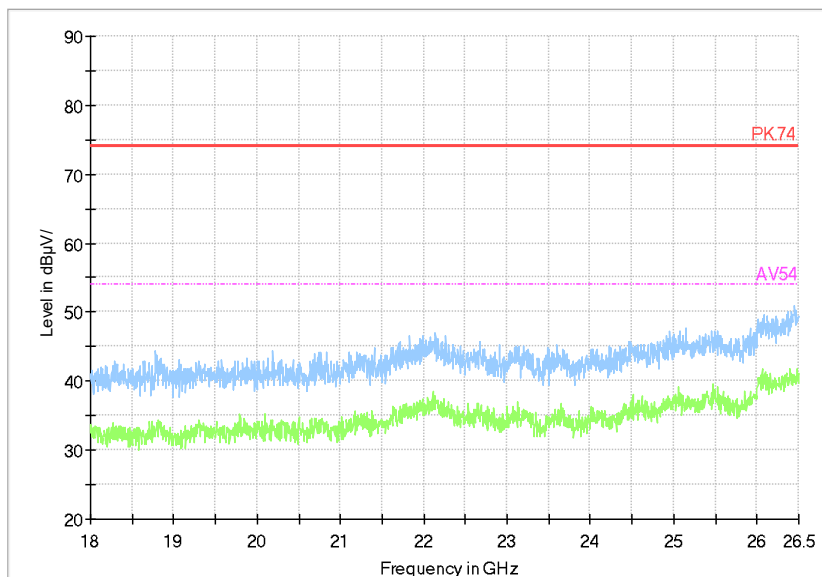

Pic8. Radiated emission (18GHz – 26GHz)

Note: The test data in the graph includes two polarizations: horizontal and vertical



### **2.2.3 20dB Bandwidth and 99% Bandwidth**

#### **Test Procedure:**

The bandwidth is measured at an amplitude level reduced from the reference level by a specified ratio. The reference level is the level of the highest amplitude signal observed from the transmitter at either the fundamental frequency or first-order modulation in all typical modes of operation, including the unmodulated carrier, even if at typical . Once the reference level is established, the equipment is conditioned with typical modulating signals to produce worst –case (i.e.,the widest) bandwidth. In order to measure the modulated signal properly, a resolution bandwidth that is small compared to the bandwidth required by the procuring or regulatory agency shall be used on the measuring instrument. However, the 6 dB resolution bandwidth of the measuring instrument shall be set to a value greater than 5% of the bandwidth requirements.

#### **Limit:**

Within the specified band!

Test result:  
20 dB bandwidth is:



Bandwidth: 229.8 Hz

99% Bandwidth:

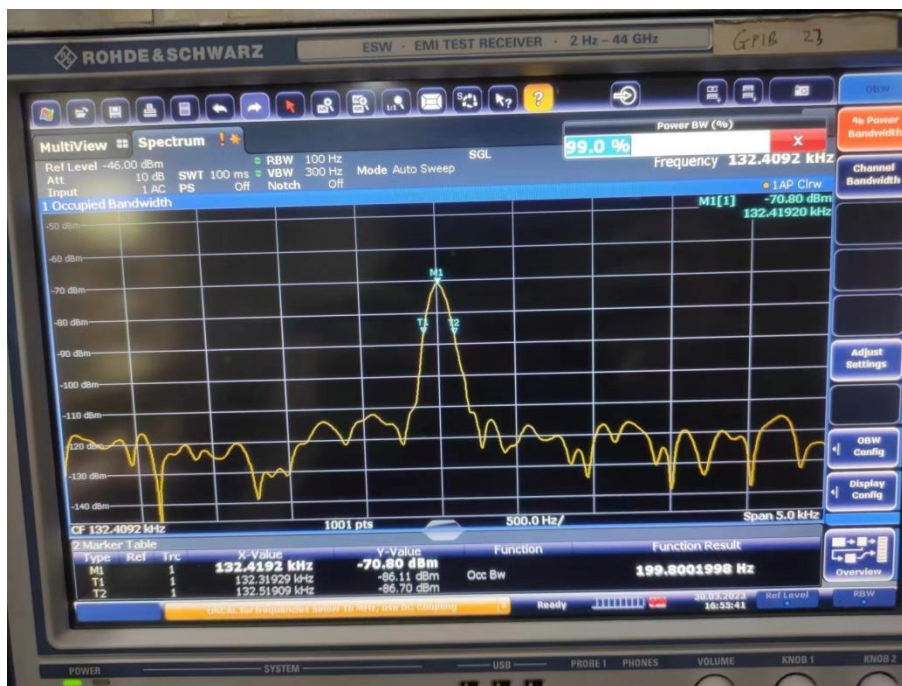

Bandwidth: 199.8Hz

### 2.3. List of test equipments

No.	Name/Model	Manufacturer	S/N	Calibration Due Date	Calibration Date
1	23.18m×16.88m×9.60mS emi-AnechoicChamber	FRANKONIA	-----	2023.09.05	2018.09.06
2	ESW EMI test receiver	R&S	101574	2023.06.19	2022.06.20
3	ESR3 EMI test receiver	R&S	102361	2024.03.11	2023.03.12
4	9.080m×5.255m×3.525m Shielding room	FRANKONIA	-----	2023.09.05	2018.09.06
5	VULB 9163 Ultra log test antenna	schwarzbeck	867	2023.05.28	2021.05.29
6	HF 907 Double-Ridged Waveguide Horn Antenna	R&S	100512	2023.05.12	2021.05.13
7	SAS-574 Horn Antenna	schwarzbeck	535	2023.06.19	2021.06.20
8	ENV216 AMN	R&S	3560.6550. 12	2023.06.19	2022.06.20
9	EMC32EMI test software	R&S	V10.20.10	-----	-----
10	HFH2-Z2 LOOP Antenna	R&S	100340	2024.08.21	2022.08.20

## Appendix

### Appendix1 Test Setup