



FCC RADIO TEST REPORT

FCC ID : APYHRO00310
Equipment : Smart phone
Brand Name : SHARP
Model Name : APYHRO00310
Applicant : SHARP CORPORATION
1 Takumi-cho, Sakai-ku, Sakai City Osaka, Japan 590-8522
Manufacturer : SHARP CORPORATION
1 Takumi-Cho, Sakai-Ku, Sakai-Shi, Osaka 590-8522, Japan
Standard : FCC 47 CFR Part 2, 22(H), 24(E), 27

The product was received on Jan. 17, 2022 and testing was performed from Feb. 19, 2022 to Mar. 09, 2022. We, Sporton International Inc. EMC & Wireless Communications Laboratory, would like to declare that the tested sample has been evaluated in accordance with the test procedures given in ANSI / TIA-603-E and has been in compliance with the applicable technical standards.

The test results in this variant report apply exclusively to the tested model / sample. Without written approval of Sporton International Inc. EMC & Wireless Communications Laboratory, the test report shall not be reproduced except in full.

Louis Wu

Approved by: Louis Wu

Sporton International Inc. EMC & Wireless Communications Laboratory

No. 52, Huaya 1st Rd., Guishan Dist., Taoyuan City 333, Taiwan (R.O.C.)



Table of Contents

History of this test report..... 3

Summary of Test Result..... 4

1 General Description 6

 1.1 Product Feature of Equipment Under Test..... 6

 1.2 Modification of EUT 6

 1.3 Testing Location 7

 1.4 Applicable Standards..... 8

2 Test Configuration of Equipment Under Test 9

 2.1 Test Mode..... 9

 2.2 Connection Diagram of Test System..... 11

 2.3 Support Unit used in test configuration and system 11

 2.4 Measurement Results Explanation Example..... 11

 2.5 Frequency List of Low/Middle/High Channels 12

3 Conducted Test Items..... 15

 3.1 Measuring Instruments 15

 3.2 Conducted Output Power and ERP/EIRP 16

 3.3 Peak-to-Average Ratio 17

 3.4 Occupied Bandwidth..... 18

 3.5 Conducted Band Edge 19

 3.6 Conducted Spurious Emission 21

 3.7 Frequency Stability 22

4 Radiated Test Items 23

 4.1 Measuring Instruments 23

 4.2 Radiated Spurious Emission Measurement 25

5 List of Measuring Equipment..... 26

6 Uncertainty of Evaluation..... 28

Appendix A. Test Results of Conducted Test

Appendix B. Test Results of Radiated Test

Appendix C. Test Setup Photographs



History of this test report

Report No.	Version	Description	Issued Date
FG211502-01B	01	Initial issue of report	Mar. 18, 2022



Summary of Test Result

Report Clause	Ref Std. Clause	Test Items	Result (PASS/FAIL)	Remark
3.2	§2.1046	Conducted Output Power	Reporting only	-
	§22.913 (a)(5)	Effective Radiated Power (Band 5)	Pass	
	§27.50 (c)(10)	Effective Radiated Power (Band 12) (Band 17)		
	§24.232 (c) §27.50 (h)(2)	Equivalent Isotropic Radiated Power (Band 2) (Band 7) (Band 38)		
3.3	§24.232 (d)	Peak-to-Average Ratio	Pass	-
3.4	§2.1049	Occupied Bandwidth	Reporting only	-
3.5	§2.1051 §22.917 (a) §24.238 (a) §27.53 (g)	Conducted Band Edge Measurement (Band 2) (Band 5) (Band 12) (Band 17)	Pass	-
	§2.1051 §27.53 (m)(4)	Conducted Band Edge Measurement (Band 7) (Band 38)		
3.6	§2.1051 §22.917 (a) §24.238 (a) §27.53 (g)	Conducted Spurious Emission (Band 2) (Band 5) (Band 12) (Band 17)	Pass	-
	§2.1051 §27.53 (m)(4)	Conducted Spurious Emission (Band 7) (Band 38)		
3.7	§2.1055 §22.355 §24.235 §27.54	Frequency Stability Temperature & Voltage	Pass	-
4.2	§2.1053 §22.917 (a) §24.238 (a) §27.53 (g)	Radiated Spurious Emission (Band 2) (Band 5) (Band 12) (Band 17)	Pass	Under limit 17.52 dB at 10404.000 MHz
	§2.1051 §27.53 (m)(4)	Radiated Spurious Emission (Band 7) (Band 38)		

Remark: This is a variant report by differences between support of WWAN Bands. includes Full test on new added LTE Band 38 .Since the RF circuit, output power level and antenna performance is the same between the two FCC IDs, all the test cases were performed on original report which can be referred to Sporton Report Number FG211502B. Based on the original report, the test cases were verified.



Declaration of Conformity:
1. The test results (PASS/FAIL) with all measurement uncertainty excluded are presented in accordance with the regulation limits or requirements declared by manufacturers. It's means measurement values may risk exceeding the limit of regulation standards, if measurement uncertainty is include in test results.
2. The measurement uncertainty please refer to this report "Uncertainty of Evaluation".
Comments and Explanations:
The product specifications of the EUT presented in the report are declared by the manufacturer who shall take full responsibility for the authenticity.

Reviewed by: Keven Cheng

Report Producer: Ruby Zou



1 General Description

1.1 Product Feature of Equipment Under Test

GSM/WCDMA/LTE, Bluetooth, Wi-Fi 2.4GHz 802.11b/g/n/ac, Wi-Fi 5GHz 802.11a/n/ac, NFC, and GNSS.

Product Feature	
Antenna Type	WWAN <Ant. 0>: Monopole Antenna <Ant. 1>: PIFA Antenna <Ant. 2>: Monopole Antenna WLAN: Loop Antenna Bluetooth: Loop Antenna GPS / Glonass / BDS / Galileo: PIFA Antenna NFC: Loop Antenna
Antenna Gain	Band 2: -0.8 dBi Band 5: -5.35 dBi Band 7: -2.84 dBi Band 12: -4.84 dBi Band 17: -4.84 dBi Band 38: -3.21 dBi

Remark: The EUT's information above was declared by manufacturer. Please refer to Comments and Explanations in report summary.

1.2 Modification of EUT

No modifications are made to the EUT during all test items.



1.3 Testing Location

Test Site	Sporton International Inc. EMC & Wireless Communications Laboratory
Test Site Location	No.52, Huaya 1st Rd., Guishan Dist., Taoyuan City 333, Taiwan (R.O.C.) TEL: +886-3-327-3456 FAX: +886-3-328-4978
Test Site No.	Sporton Site No.
	TH03-HY
Test Engineer	George Chen
Temperature (°C)	22.5~24.7
Relative Humidity (%)	50.7~58.3

Test Site	Sporton International Inc. Wensan Laboratory
Test Site Location	No.58, Aly. 75, Ln. 564, Wenhua 3rd, Rd., Guishan Dist., Taoyuan City 333010, Taiwan (R.O.C.) TEL: +886-3-327-0868 FAX: +886-3-327-0855
Test Site No.	Sporton Site No.
	03CH13-HY (TAF Code: 3786)
Test Engineer	Yuan Lee, Jacky Hong, and Peter Liao
Temperature (°C)	20~25
Relative Humidity (%)	50~60
Remark	The Radiated Test Items subcontracted to Sporton International Inc. Wensan Laboratory.

Note: The test site complies with ANSI C63.4 2014 requirement.

FCC Designation No.: TW1190 and TW3786



1.4 Applicable Standards

According to the specifications of the manufacturer, the EUT must comply with the requirements of the following standards:

- ♦ ANSI C63.26-2015
- ♦ ANSI / TIA-603-E
- ♦ FCC 47 CFR Part 2, 22(H), 24(E), 27
- ♦ FCC KDB 971168 D01 Power Meas. License Digital Systems v03r01
- ♦ FCC KDB 412172 D01 Determining ERP and EIRP v01r01
- ♦ FCC KDB 414788 D01 Radiated Test Site v01r01.

Remark:

1. All test items were verified and recorded according to the standards and without any deviation during the test.
2. This EUT has also been tested and complied with the requirements of FCC Part 15, Subpart B, recorded in a separate test report.
3. The TAF code is not including all the FCC KDB listed without accreditation.



2 Test Configuration of Equipment Under Test

2.1 Test Mode

Antenna port conducted and radiated test items listed below are performed according to KDB 971168 D01 Power Meas. License Digital Systems v03r01 with maximum output power.

For radiated measurement, the measured emission level of the EUT was maximized by rotating the EUT on a turntable, adjusting the orientation of the EUT and EUT antenna in three orthogonal axis (X: flat, Y: portrait, Z: landscape), and adjusting the measurement antenna orientation, following C63.26 exploratory test procedures and find X Plane LTE Band 5, Band 7 and Band 38 and Z Plane for LTE Band 2 and Band 12 as worst plane.

Test Items	Band	Bandwidth (MHz)						Modulation			RB #			Test Channel		
		1.4	3	5	10	15	20	QPSK	16QAM	64QAM	1	Half	Full	L	M	H
Max. Output Power	2	v	v	v	v	v	v	v	v	v	v	v	v	v	v	v
	5	v	v	v	v	-	-	v	v	v	v	v	v	v	v	v
	7	-	-	v	v	v	v	v	v	v	v	v	v	v	v	v
	12	v	v	v	v	-	-	v	v	v	v	v	v	v	v	v
	17	-	-	v	v	-	-	v	v	v	v	v	v	v	v	v
E.R.P / E.I.R.P	2	v	v	v	v	v	v	v	v	v	Max. Power					
	5	v	v	v	v	-	-	v	v	v						
	7	-	-	v	v	v	v	v	v	v						
	12	v	v	v	v	-	-	v	v	v						
	17	-	-	v	v	-	-	v	v	v						
Radiated Spurious Emission	2						v	v					v	v		
	5				v	-	-	v					v	v		
	7	-	-				v	v					v			v
	12				v	-	-	v					v		v	
	17	Covered by LTE Band 12														
Remark	<ol style="list-style-type: none"> The mark "v" means that this configuration is chosen for testing The mark "-" means that this bandwidth is not supported. The device is investigated from 30MHz to 10 times of fundamental signal for radiated spurious emission test under different RB size/offset and modulations in exploratory test. Subsequently, only the worst case emissions are reported. Wider operating range bandwidth covers narrower one when the power is higher or the same. 															



Test Items	Band	Bandwidth (MHz)						Modulation			RB #			Test Channel		
		1.4	3	5	10	15	20	QPSK	16QAM	64QAM	1	Half	Full	L	M	H
Max. Output Power	38	-	-	v	v	v	v	v	v	v	v	v	v	v	v	v
Peak-to-Average Ratio	38	-	-				v	v	v	v	v		v		v	
26dB and 99% Bandwidth	38	-	-	v	v	v	v	v	v	v			v		v	
Conducted Band Edge	38	-	-	v	v	v	v	v	v	v	v		v	v	v	
Conducted Spurious Emission	38	-	-	v	v	v	v	v			v		v	v	v	
Frequency Stability	38	-	-		v			v					v		v	
E.R.P / E.I.R.P	38	-	-	v	v	v	v	v	v	v	Max. Power					
Radiated Spurious Emission	38	Worst Case											v	v	v	
Remark	<ol style="list-style-type: none"> The mark "v " means that this configuration is chosen for testing The mark "-" means that this bandwidth is not supported. The device is investigated from 30MHz to 10 times of fundamental signal for radiated spurious emission test under different RB size/offset and modulations in exploratory test. Subsequently, only the worst case emissions are reported. 															

2.2 Connection Diagram of Test System

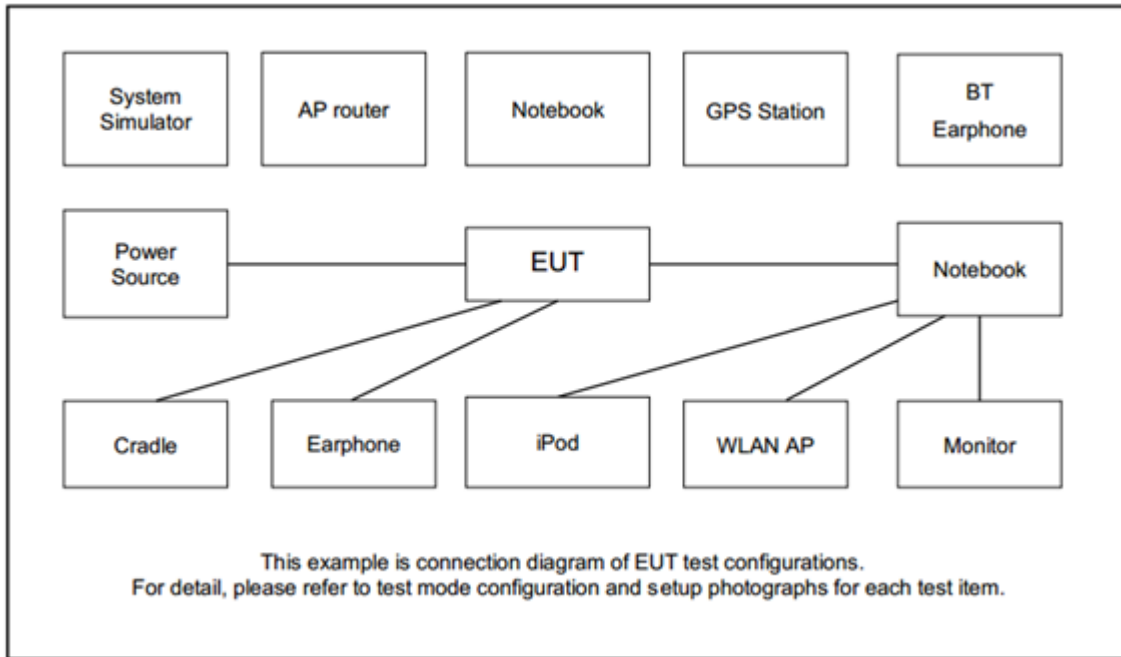

2.3 Support Unit used in test configuration and system

Item	Equipment	Brand Name	Model No.	FCC ID	Data Cable	Power Cord
1.	Earphone	Nokia	WH-108	N/A	Unshielded, 1.5m	N/A
2.	System Simulator	Anritsu	8821C	N/A	N/A	Unshielded, 1.8 m

2.4 Measurement Results Explanation Example

For all conducted test items:

The offset level is set in the spectrum analyzer to compensate the RF cable loss and attenuator factor between EUT conducted output port and spectrum analyzer. With the offset compensation, the spectrum analyzer reading level is exactly the EUT RF output level.

The spectrum analyzer offset is derived from RF cable loss and attenuator factor.

Offset = RF cable loss + attenuator factor.

Following shows an offset computation example with cable loss 4.2 dB and 10dB attenuator.

Example :

$$\begin{aligned} \text{Offset(dB)} &= \text{RF cable loss(dB)} + \text{attenuator factor(dB)}. \\ &= 4.2 + 10 = 14.2 \text{ (dB)} \end{aligned}$$



2.5 Frequency List of Low/Middle/High Channels

LTE Band 2 Channel and Frequency List				
BW [MHz]	Channel/Frequency(MHz)	Lowest	Middle	Highest
20	Channel	18700	18900	19100
	Frequency	1860	1880	1900
15	Channel	18675	18900	19125
	Frequency	1857.5	1880	1902.5
10	Channel	18650	18900	19150
	Frequency	1855	1880	1905
5	Channel	18625	18900	19175
	Frequency	1852.5	1880	1907.5
3	Channel	18615	18900	19185
	Frequency	1851.5	1880	1908.5
1.4	Channel	18607	18900	19193
	Frequency	1850.7	1880	1909.3

LTE Band 5 Channel and Frequency List				
BW [MHz]	Channel/Frequency(MHz)	Lowest	Middle	Highest
10	Channel	20450	20525	20600
	Frequency	829	836.5	844
5	Channel	20425	20525	20625
	Frequency	826.5	836.5	846.5
3	Channel	20415	20525	20635
	Frequency	825.5	836.5	847.5
1.4	Channel	20407	20525	20643
	Frequency	824.7	836.5	848.3



LTE Band 7 Channel and Frequency List				
BW [MHz]	Channel/Frequency(MHz)	Lowest	Middle	Highest
20	Channel	20850	21100	21350
	Frequency	2510	2535	2560
15	Channel	20825	21100	21375
	Frequency	2507.5	2535	2562.5
10	Channel	20800	21100	21400
	Frequency	2505	2535	2565
5	Channel	20775	21100	21425
	Frequency	2502.5	2535	2567.5

LTE Band 12 Channel and Frequency List				
BW [MHz]	Channel/Frequency(MHz)	Lowest	Middle	Highest
10	Channel	23060	23095	23130
	Frequency	704	707.5	711
5	Channel	23035	23095	23155
	Frequency	701.5	707.5	713.5
3	Channel	23025	23095	23165
	Frequency	700.5	707.5	714.5
1.4	Channel	23017	23095	23173
	Frequency	699.7	707.5	715.3

LTE Band 17 Channel and Frequency List				
BW [MHz]	Channel/Frequency(MHz)	Lowest	Middle	Highest
10	Channel	23780	23790	23800
	Frequency	709	710	711
5	Channel	23755	23790	23825
	Frequency	706.5	710	713.5



LTE Band 38 Channel and Frequency List				
BW [MHz]	Channel/Frequency(MHz)	Lowest	Middle	Highest
20	Channel	37850	38000	38150
	Frequency	2580.0	2595.0	2610.0
15	Channel	37825	38000	38175
	Frequency	2577.5	2595.0	2612.5
10	Channel	37800	38000	38200
	Frequency	2575.0	2595.0	2615.0
5	Channel	37775	38000	38225
	Frequency	2572.5	2595.0	2617.5

3 Conducted Test Items

3.1 Measuring Instruments

See list of measuring instruments of this test report.

3.1.1 Test Setup

3.1.2 Conducted Output Power

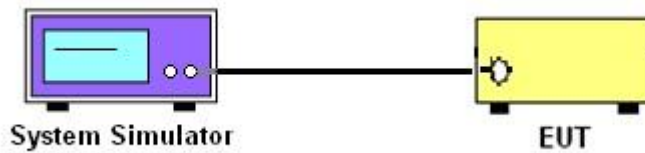

3.1.3 Peak-to-Average Ratio, Occupied Bandwidth ,Conducted Band-Edge and Conducted Spurious Emission

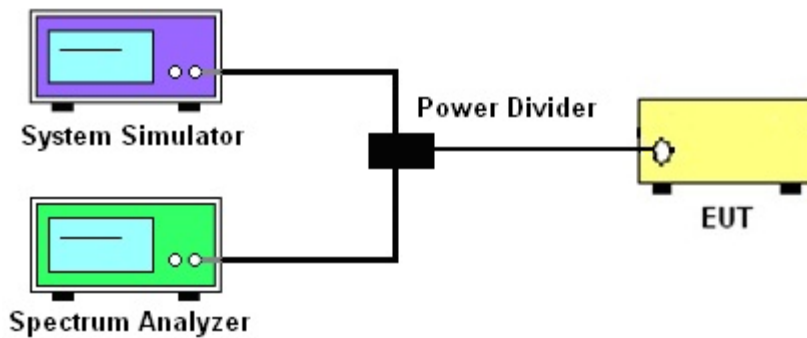

3.1.4 Frequency Stability

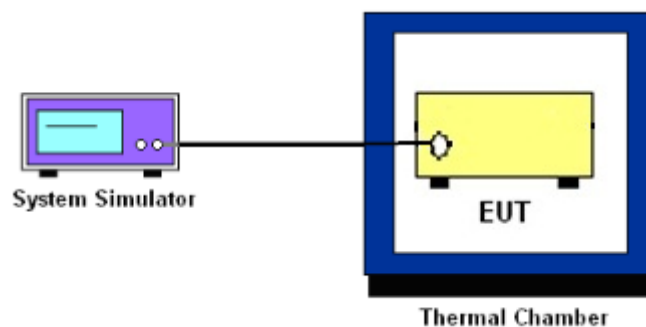

3.1.5 Test Result of Conducted Test

Please refer to Appendix A.



3.2 Conducted Output Power and ERP/EIRP

3.2.1 Description of the Conducted Output Power Measurement and ERP/EIRP Measurement

A system simulator was used to establish communication with the EUT. Its parameters were set to force the EUT transmitting at maximum output power. The measured power in the radio frequency on the transmitter output terminals shall be reported.

The ERP of mobile transmitters must not exceed 7 Watts for LTE Band 5

The ERP of mobile transmitters must not exceed 3 Watts for LTE Band 12 and Band 17

The EIRP of mobile transmitters must not exceed 2 Watts for LTE Band 2 and Band 7 and Band 38

According to KDB 412172 D01 Power Approach,

$EIRP = P_T + G_T - L_C$, $ERP = EIRP - 2.15$, where

P_T = transmitter output power in dBm

G_T = gain of the transmitting antenna in dBi

L_C = signal attenuation in the connecting cable between the transmitter and antenna in dB

3.2.2 Test Procedures

1. The transmitter output port was connected to the system simulator.
2. Set EUT at maximum power through the system simulator.
3. Select lowest, middle, and highest channels for each band and different modulation.
4. Measure and record the power level from the system simulator.



3.3 Peak-to-Average Ratio

3.3.1 Description of the PAR Measurement

Power Complementary Cumulative Distribution Function (CCDF) curves provide a means for characterizing the power peaks of a digitally modulated signal on a statistical basis. A CCDF curve depicts the probability of the peak signal amplitude exceeding the average power level. Most contemporary measurement instrumentation include the capability to produce CCDF curves for an input signal provided that the instrument's resolution bandwidth can be set wide enough to accommodate the entire input signal bandwidth. In measuring transmissions in this band using an average power technique, the peak-to-average ratio (PAR) of the transmission may not exceed 13 dB.

3.3.2 Test Procedures

The testing follows ANSI C63.26-2015 Section 5.2.6

1. The EUT was connected to spectrum and system simulator via a power divider.
2. Set the CCDF (Complementary Cumulative Distribution Function) option in spectrum analyzer.
3. The highest RF powers were measured and recorded the maximum PAPR level associated with a probability of 0.1 %.
4. Record the deviation as Peak to Average Ratio.



3.4 Occupied Bandwidth

3.4.1 Description of Occupied Bandwidth Measurement

The occupied bandwidth is the width of a frequency band such that, below the lower and above the upper frequency limits, the mean powers emitted are each equal to a specified percentage 0.5% of the total mean transmitted power.

The 26 dB emission bandwidth is defined as the frequency range between two points, one above and one below the carrier frequency, at which the spectral density of the emission is attenuated 26 dB below the maximum in-band spectral density of the modulated signal. Spectral density (power per unit bandwidth) is to be measured with a detector of resolution bandwidth equal to approximately 1.0% of the emission bandwidth.

3.4.2 Test Procedures

The testing follows ANSI C63.26-2015 Section 5.4.3 (26dB) and Section 5.4.4 (99OB)

1. The EUT was connected to spectrum analyzer and system simulator via a power divider.
2. The spectrum analyzer center frequency is set to the nominal EUT channel center frequency. The span range for the spectrum analyzer shall be between two and five times the anticipated OBW.
3. The nominal resolution bandwidth (RBW) shall be in the range of 1 to 5 % of the anticipated OBW, and the VBW shall be at least 3 times the RBW.
4. Set the detection mode to peak, and the trace mode to max hold.
5. Determine the reference value: Set the EUT to transmit a modulated signal. Allow the trace to stabilize. Set the spectrum analyzer marker to the highest level of the displayed trace.
(this is the reference value)
6. Determine the “-26 dB down amplitude” as equal to (Reference Value – X).
7. Place two markers, one at the lowest and the other at the highest frequency of the envelope of the spectral display such that each marker is at or slightly below the “-X dB down amplitude” determined in step 6. If a marker is below this “-X dB down amplitude” value it shall be placed as close as possible to this value. The OBW is the positive frequency difference between the two markers.
8. Use the 99 % power bandwidth function of the spectrum analyzer and report the measured bandwidth.



3.5 Conducted Band Edge

3.5.1 Description of Conducted Band Edge Measurement

22.917(a)

For operations in the 824 – 849 MHz band, the FCC limit is $43 + 10\log_{10}(P[\text{Watts}])$ dB below the transmitter power $P(\text{Watts})$ in a 100kHz bandwidth. However, in the 1MHz bands immediately outside and adjacent to the licensee's frequency block, a resolution bandwidth of at least one percent of the emission bandwidth of the fundamental emission of the transmitter may be employed.

24.238 (a)

For operations in the 1850-1910 and 1930-1990 MHz band, the FCC limit is $43 + 10\log_{10}(P[\text{Watts}])$ dB below the transmitter power $P(\text{Watts})$ in a 1MHz bandwidth. However, in the 1 MHz bands immediately outside and adjacent to the frequency block a resolution bandwidth of at least one percent of the emission bandwidth of the fundamental emission of the transmitter may be employed.

27.53 (g)

For operations in the 600MHz band and 698-746 MHz band, the FCC limit is $43 + 10\log_{10}(P[\text{Watts}])$ dB below the transmitter power $P(\text{Watts})$ in a 100 kHz bandwidth. However, in the 100 kilohertz bands immediately outside and adjacent to a licensee's frequency block, a resolution bandwidth of at least 30 kHz may be employed.

**27.53(m)(4)**

For mobile digital stations, the attenuation factor shall be not less than $40 + 10 \log (P)$ dB on all frequencies between the channel edge and 5 megahertz from the channel edge, $43 + 10 \log (P)$ dB on all frequencies between 5 megahertz and X megahertz from the channel edge, and $55 + 10 \log (P)$ dB on all frequencies more than X megahertz from the channel edge, where X is the greater of 6 megahertz or the actual emission bandwidth as defined in paragraph (m)(6) of this section. In addition, the attenuation factor shall not be less that $43 + 10 \log (P)$ dB on all frequencies between 2490.5 MHz and 2496 MHz and $55 + 10 \log (P)$ dB at or below 2490.5 MHz. Mobile Satellite Service licensees operating on frequencies below 2495 MHz may also submit a documented interference complaint against BRS licensees operating on channel BRS Channel 1 on the same terms and conditions as adjacent channel BRS or EBS licensees.

3.5.2 Test Procedures

The testing follows FCC KDB 971168 D01 v03r01 Section 6.1.

1. The EUT was connected to spectrum analyzer and system simulator via a power divider.
2. The band edges of low and high channels for the highest RF powers were measured.
3. Set RBW \geq 1% EBW in the 1MHz band immediately outside and adjacent to the band edge.
4. Beyond the 1 MHz band from the band edge, RBW=1MHz was used.
5. Set spectrum analyzer with RMS detector.
6. The RF fundamental frequency should be excluded against the limit line in the operating frequency band.
7. Checked that all the results comply with the emission limit line.

The limit line is derived from $43 + 10\log(P)$ dB below the transmitter power P(Watts)

For LTE Band 7, 38

The other 40 dB, and 55 dB have additionally applied same calculation above.



3.6 Conducted Spurious Emission

3.6.1 Description of Conducted Spurious Emission Measurement

The power of any emission outside of the authorized operating frequency ranges must be lower than the transmitter power (P) by a factor of at least $43 + 10 \log (P)$ dB.

For LTE Band 7, 38

The power of any emission outside of the authorized operating frequency ranges must be lower than the transmitter power (P) by a factor of at least $55 + 10 \log (P)$ dB.

It is measured by means of a calibrated spectrum analyzer and scanned from 30 MHz up to a frequency including its 10th harmonic.

3.6.2 Test Procedures

The testing follows FCC KDB 971168 D01 v03r01 Section 6.1.

1. The EUT was connected to spectrum analyzer and system simulator via a power divider.
2. The RF output of EUT was connected to the spectrum analyzer by RF cable and attenuator.
The path loss was compensated to the results for each measurement.
3. The middle channel for the highest RF power within the transmitting frequency was measured.
4. The conducted spurious emission for the whole frequency range was taken.
5. Make the measurement with the spectrum analyzer's RBW = 1MHz, VBW = 3MHz.
6. Set spectrum analyzer with RMS detector.
7. Taking the record of maximum spurious emission.
8. The RF fundamental frequency should be excluded against the limit line in the operating frequency band.
9. The limit line is derived from $43 + 10\log(P)$ dB below the transmitter power P(Watts)
For LTE Band 7, 38
The limit line is derived from $55 + 10\log(P)$ dB below the transmitter power P(Watts)



3.7 Frequency Stability

3.7.1 Description of Frequency Stability Measurement

22.355

The frequency stability shall be measured by variation of ambient temperature and variation of primary supply voltage to ensure that the fundamental emission stays within the authorized frequency block. The frequency stability of the transmitter shall be maintained within $\pm 0.00025\%$ ($\pm 2.5\text{ppm}$) of the center frequency.

24.235 & 27.54

The frequency stability shall be sufficient to ensure that the fundamental emission stays within the authorized frequency block.

3.7.2 Test Procedures for Temperature Variation

The testing follows FCC KDB 971168 D01 v03r01 Section 9.0.

1. The EUT was set up in the thermal chamber and connected with the system simulator.
2. With power OFF, the temperature was decreased to -30°C and the EUT was stabilized before testing. Power was applied and the maximum change in frequency was recorded within one minute.
3. With power OFF, the temperature was raised in 10°C step up to 50°C . The EUT was stabilized at each step for at least half an hour. Power was applied and the maximum frequency change was recorded within one minute.

3.7.3 Test Procedures for Voltage Variation

The testing follows FCC KDB 971168 D01 v03r01 Section 9.0.

1. The EUT was placed in a temperature chamber at $20\pm 5^{\circ}\text{C}$ and connected with the system simulator.
2. The power supply voltage to the EUT was varied from 85% to 115% of the nominal value measured at the input to the EUT.
3. The variation in frequency was measured for the worst case.

4 Radiated Test Items

4.1 Measuring Instruments

See list of measuring instruments of this test report.

4.1.1 Test Setup

For radiated test below 30MHz

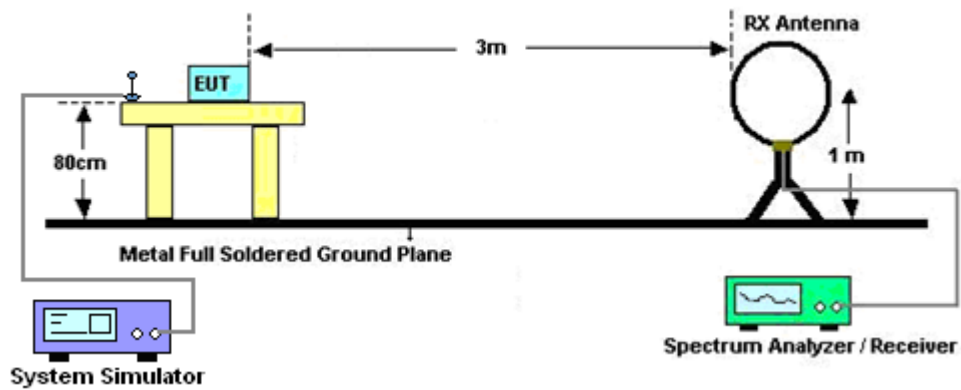

For radiated test from 30MHz to 1GHz

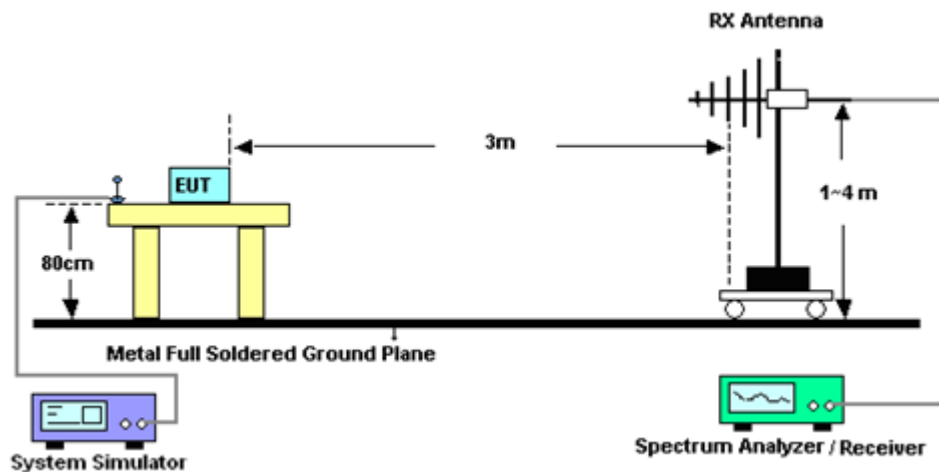

For radiated test from 1GHz to 18GHz

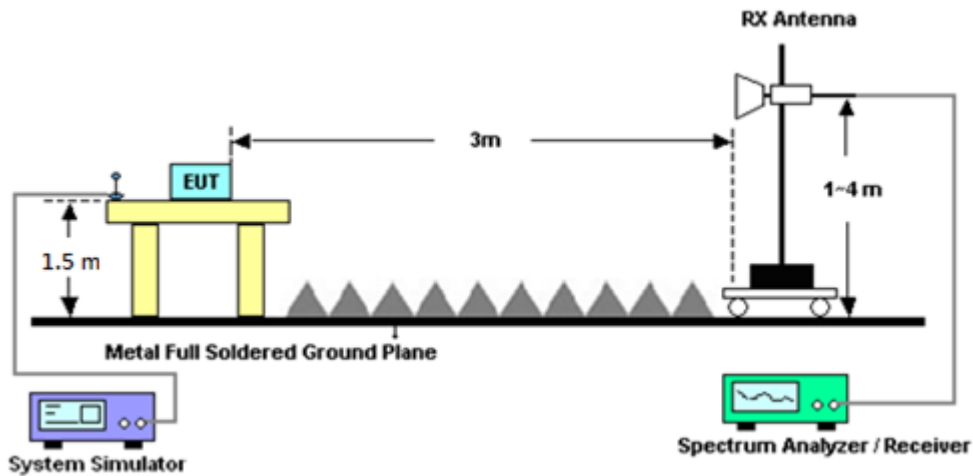

For radiated test above 18GHz

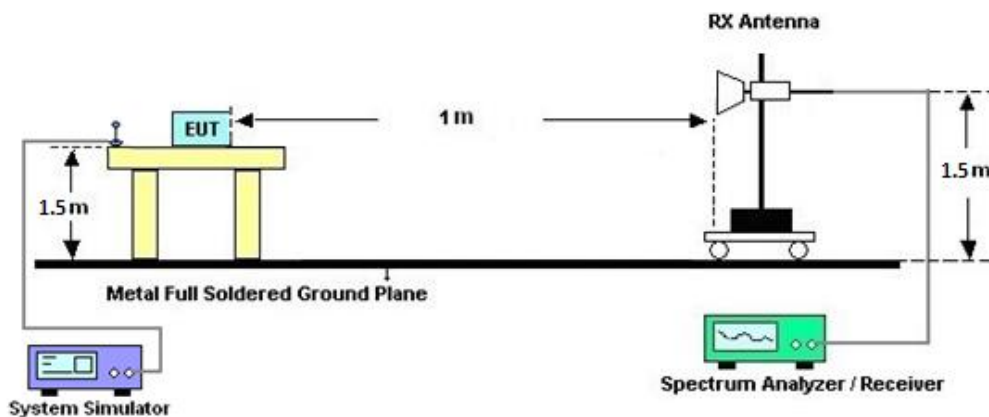

4.1.2 Test Result of Radiated Test

Please refer to Appendix B.

Note:

The low frequency, which started from 9 kHz to 30MHz, was pre-scanned and the result which was 20dB lower than the limit line was not reported.

There is adequate comparison measurement of both open-field test site and alternative test site - semi-Anechoic chamber according to 414788 D01 Radiated Test Site v01r01, and the result came out very similar.



4.2 Radiated Spurious Emission Measurement

4.2.1 Description of Radiated Spurious Emission Measurement

The radiated spurious emission was measured by substitution method according to ANSI / TIA-603-E. The power of any emission outside of the authorized operating frequency ranges must be attenuated below the transmitter power (P) by a factor of at least $43 + 10 \log (P)$ dB.

For LTE Band 7, 38

The power of any emission outside of the authorized operating frequency ranges must be attenuated below the transmitter power (P) by a factor of at least $55 + 10 \log (P)$ dB.

The spectrum is scanned from 30 MHz up to a frequency including its 10th harmonic.

4.2.2 Test Procedures

The testing follows FCC KDB 971168 D01 v03r01 Section 7 and ANSI / TIA-603-E Section 2.2.12.

1. The EUT was placed on a turntable with 0.8 meter for frequency below 1GHz and 1.5 meter for frequency above 1GHz respectively above ground.
2. The EUT was set 3 meters from the receiving antenna, which was mounted on the antenna tower.
3. The table was rotated 360 degrees to determine the position of the highest spurious emission.
4. The height of the receiving antenna is varied between one meter and four meters to search the maximum spurious emission for both horizontal and vertical polarizations.
5. Make the measurement with the spectrum analyzer's RBW = 1MHz, VBW = 3MHz, taking the record of maximum spurious emission.
6. A horn antenna was substituted in place of the EUT and was driven by a signal generator.
7. Tune the output power of signal generator to the same emission level with EUT maximum spurious emission.
8. Taking the record of output power at antenna port.
9. Repeat step 7 to step 8 for another polarization.
10. The RF fundamental frequency should be excluded against the limit line in the operating frequency band.

The limit line is derived from $43 + 10\log(P)$ dB below the transmitter power P(Watts)

For LTE Band 7, 38

The limit line is derived from $55 + 10\log(P)$ dB below the transmitter power P(Watts)

EIRP (dBm) = S.G. Power – Tx Cable Loss + Tx Antenna Gain

ERP (dBm) = EIRP - 2.15



5 List of Measuring Equipment

Instrument	Brand Name	Model No.	Serial No.	Characteristics	Calibration Date	Test Date	Due Date	Remark
Loop Antenna	Rohde & Schwarz	HFH2-Z2	100488	9kHz~30MHz	Sep. 07, 2021	Mar. 06, 2022~ Mar. 07, 2022	Sep. 06, 2022	Radiation (03CH13-HY)
Bilog Antenna	TESEQ	CBL 6111D&00800 N1D01N-06	40103 & 07	30MHz~1GHz	Apr. 28, 2021	Mar. 06, 2022~ Mar. 07, 2022	Apr. 27, 2022	Radiation (03CH13-HY)
Bilog Antenna	TESEQ	CBL 6111D&00802 N1D01N-06	54682 & AT-N0603	30MHz~1GHz	Sep. 09, 2021	Mar. 06, 2022~ Mar. 07, 2022	Sep. 08, 2022	Radiation (03CH13-HY)
Amplifier	Sonoma-Instru ment	310 N	187282	9kHz~1GHz	Dec. 15, 2021	Mar. 06, 2022~ Mar. 07, 2022	Dec. 14, 2022	Radiation (03CH13-HY)
Horn Antenna	SCHWARZBE CK	BBHA 9120 D	9120D-1212	1GHz~18GHz	May 18, 2021	Mar. 06, 2022~ Mar. 07, 2022	May 17, 2022	Radiation (03CH13-HY)
Horn Antenna	SCHWARZBE CK	BBHA 9120 D	9120D-1241	1GHz~18GHz	Jul. 13, 2021	Mar. 06, 2022~ Mar. 07, 2022	Jul. 12, 2022	Radiation (03CH13-HY)
Preamplifier	MITEQ	AMF-7D-0010 1800-30-10P	1590074	1GHz~18GHz	May 18, 2021	Mar. 06, 2022~ Mar. 07, 2022	May 17, 2022	Radiation (03CH13-HY)
Preamplifier	Keysight	83017A	MY53270147	1GHz~26.5GHz	Oct. 26, 2021	Mar. 06, 2022~ Mar. 07, 2022	Oct. 25, 2022	Radiation (03CH13-HY)
SHF-EHF Horn Antenna	SCHWARZBE CK	BBHA 9170	00993	18GHz~40GHz	Nov. 30, 2021	Mar. 06, 2022~ Mar. 07, 2022	Nov. 29, 2022	Radiation (03CH13-HY)
SHF-EHF Horn Antenna	SCHWARZBE CK	BBHA 9170	00994	18GHz~40GHz	Nov. 04, 2021	Mar. 06, 2022~ Mar. 07, 2022	Nov. 03, 2022	Radiation (03CH13-HY)
Preamplifier	EMEC	EM18G40G	060801	18GHz~40GHz	Jun. 22, 2021	Mar. 06, 2022~ Mar. 07, 2022	Jun. 21, 2022	Radiation (03CH13-HY)
Spectrum Analyzer	Keysight	N9010A	MY55370526	10Hz~44GHz	Mar. 18, 2021	Mar. 06, 2022~ Mar. 07, 2022	Mar. 17, 2022	Radiation (03CH13-HY)
Signal Generator	Rohde & Schwarz	SMF100A	101107	100kHz~40GHz	Dec. 08, 2021	Mar. 06, 2022~ Mar. 07, 2022	Dec. 07, 2022	Radiation (03CH13-HY)
Filter	Wainwright	WHKX12-2700 -3000-18000-6 0SS	SN2	3GHz High Pass Filter	Jul. 12, 2021	Mar. 06, 2022~ Mar. 07, 2022	Jul. 11, 2022	Radiation (03CH13-HY)
RF Cable	HUBER + SUHNER	SUCOFLEX 104	MY9837/4PE	9kHz~30MHz	Mar. 11, 2021	Mar. 06, 2022~ Mar. 07, 2022	Mar. 10, 2022	Radiation (03CH13-HY)
RF Cable	HUBER + SUHNER	SUCOFLEX 126E	0030/126E	30MHz~18GHz	Feb. 09, 2022	Mar. 06, 2022~ Mar. 07, 2022	Feb. 08, 2023	Radiation (03CH13-HY)
RF Cable	HUBER + SUHNER	SUCOFLEX 104	804793/4	30MHz~18GHz	Feb. 09, 2022	Mar. 06, 2022~ Mar. 07, 2022	Feb. 08, 2023	Radiation (03CH13-HY)
RF Cable	HUBER + SUHNER	SUCOFLEX 104	MY24961/4	30MHz~18GHz	Feb. 09, 2022	Mar. 06, 2022~ Mar. 07, 2022	Feb. 08, 2023	Radiation (03CH13-HY)
RF Cable	HUBER + SUHNER	SUCOFLEX 102	804011/2, 804012/2	18GHz~40GHz	Jan. 04, 2022	Mar. 06, 2022~ Mar. 07, 2022	Jan. 03, 2023	Radiation (03CH13-HY)
Hygrometer	TECPEL	DTM-303B	TP200889	N/A	Sep. 30, 2021	Mar. 06, 2022~ Mar. 07, 2022	Sep. 29, 2022	Radiation (03CH13-HY)
Controller	EMEC	EM1000	N/A	Control Turn table & Ant Mast	N/A	Mar. 06, 2022~ Mar. 07, 2022	N/A	Radiation (03CH13-HY)
Antenna Mast	EMEC	AM-BS-4500-B	N/A	1m~4m	N/A	Mar. 06, 2022~ Mar. 07, 2022	N/A	Radiation (03CH13-HY)
Turn Table	EMEC	TT2000	N/A	0~360 Degree	N/A	Mar. 06, 2022~ Mar. 07, 2022	.N/A	Radiation (03CH13-HY)
Software	Audix	E3 6.2009-8-24	RK-000992	N/A	N/A	Mar. 06, 2022~ Mar. 07, 2022	N/A	Radiation (03CH13-HY)



Instrument	Brand Name	Model No.	Serial No.	Characteristics	Calibration Date	Test Date	Due Date	Remark
Radio Communication Analyzer	Anritsu	MT8821C	6201664755	2/3/4G/LTE FDD/TDD with 44/LTE-3C C DLCA/2CC ULCA, CatM1/NB1/NB2	Jul. 21, 2021	Feb. 19, 2022~ Mar. 09, 2022	Jul. 20, 2022	Conducted (TH03-HY)
Spectrum Analyzer	Rohde & Schwarz	FSV40	101908	10Hz~40GHz	Oct. 01, 2021	Feb. 19, 2022~ Mar. 09, 2022	Sep. 30, 2022	Conducted (TH03-HY)
Thermal Chamber	ESPEC	SH-641	92013720	-40°C ~90°C	Sep. 09, 2021	Feb. 19, 2022~ Mar. 09, 2022	Sep. 08, 2022	Conducted (TH03-HY)
DC Power Supply	GW Instek	GPP-2323	GES906037	0V~64V : 0A~6A	Jan. 06, 2022	Feb. 19, 2022~ Mar. 09, 2022	Jan. 05, 2023	Conducted (TH03-HY)
Coupler	Warison	20dB 25W SMA Directional Coupler	#B	1-18GHz	Jan. 07, 2022	Feb. 19, 2022~ Mar. 09, 2022	Jan. 06, 2023	Conducted (TH03-HY)



6 Uncertainty of Evaluation

Uncertainty of Radiated Emission Measurement (30 MHz ~ 1000 MHz)

Measuring Uncertainty for a Level of Confidence of 95% ($U = 2Uc(y)$)	3.45 dB
---	---------

Uncertainty of Radiated Emission Measurement (1 GHz ~ 18 GHz)

Measuring Uncertainty for a Level of Confidence of 95% ($U = 2Uc(y)$)	3.73 dB
---	---------

Uncertainty of Radiated Emission Measurement (18 GHz ~ 40 GHz)

Measuring Uncertainty for a Level of Confidence of 95% ($U = 2Uc(y)$)	4.00 dB
---	---------



Appendix A. Test Results of Conducted Test

Conducted Output Power(Average power & ERP/EIRP)

LTE Band 2 Maximum Average Power [dBm] (GT - LC = -0.8 dB)								
BW [MHz]	RB Size	RB Offset	Mod	Lowest	Middle	Highest	EIRP (dBm)	EIRP (W)
20	1	0	QPSK	22.67	22.37	22.51	21.87	0.1538
20	1	49		22.58	22.55	22.52		
20	1	99		22.58	22.40	22.27		
20	50	0		21.62	21.72	21.67		
20	50	24		21.47	21.50	21.38		
20	50	50		21.76	21.52	21.78		
20	100	0		21.63	21.41	21.66		
20	1	0	16-QAM	21.72	21.78	21.85	21.24	0.1330
20	1	49		21.95	21.79	21.69		
20	1	99		21.84	22.04	21.97		
20	50	0		20.43	20.68	20.42		
20	50	24		20.71	20.77	20.41		
20	50	50		20.75	20.64	20.63		
20	100	0		20.61	20.44	20.51		
20	1	0	64-QAM	20.65	20.60	20.75	20.06	0.1014
20	1	49		20.38	20.77	20.64		
20	1	99		20.53	20.80	20.86		
20	50	0		19.79	19.52	19.78		
20	50	24		19.67	19.51	19.69		
20	50	50		19.65	19.73	19.41		
20	100	0		19.44	19.72	19.67		
Limit	EIRP < 2W			Result			Pass	



LTE Band 2 Maximum Average Power [dBm] (GT - LC = -0.8 dB)								
BW [MHz]	RB Size	RB Offset	Mod	Lowest	Middle	Highest	EIRP (dBm)	EIRP (W)
15	1	0	QPSK	22.37	22.64	22.32	21.84	0.1528
15	1	37		22.29	22.44	22.43		
15	1	74		22.57	22.31	22.50		
15	36	0		21.56	21.42	21.60		
15	36	20		21.51	21.63	21.40		
15	36	39		21.76	21.58	21.52		
15	75	0		21.67	21.74	21.41		
15	1	0	16-QAM	21.60	21.88	21.85	21.20	0.1318
15	1	37		21.94	22.00	21.80		
15	1	74		21.86	21.87	21.84		
15	36	0		20.69	20.37	20.54		
15	36	20		20.40	20.74	20.46		
15	36	39		20.62	20.80	20.41		
15	75	0		20.65	20.39	20.60		
15	1	0	64-QAM	20.41	20.57	20.59	20.04	0.1009
15	1	37		20.25	20.54	20.58		
15	1	74		20.47	20.84	20.50		
15	36	0		19.29	19.46	19.67		
15	36	20		19.51	19.45	19.57		
15	36	39		19.52	19.62	19.39		
15	75	0		19.61	19.49	19.74		
Limit	EIRP < 2W			Result			Pass	



LTE Band 2 Maximum Average Power [dBm] (GT - LC = -0.8 dB)								
BW [MHz]	RB Size	RB Offset	Mod	Lowest	Middle	Highest	EIRP (dBm)	EIRP (W)
10	1	0	QPSK	22.29	22.45	22.45	21.77	0.1503
10	1	25		22.57	22.48	22.40		
10	1	49		22.53	22.27	22.52		
10	25	0		21.53	21.59	21.42		
10	25	12		21.40	21.49	21.42		
10	25	25		21.46	21.55	21.66		
10	50	0		21.54	21.60	21.49		
10	1	0	16-QAM	21.64	21.78	22.00	21.20	0.1318
10	1	25		21.78	21.85	21.93		
10	1	49		21.65	21.87	21.52		
10	25	0		20.66	20.44	20.71		
10	25	12		20.53	20.70	20.53		
10	25	25		20.55	20.66	20.32		
10	50	0		20.43	20.68	20.36		
10	1	0	64-QAM	20.48	20.55	20.75	20.08	0.1019
10	1	25		20.44	20.79	20.65		
10	1	49		20.60	20.88	20.80		
10	25	0		19.68	19.68	19.73		
10	25	12		19.68	19.76	19.50		
10	25	25		19.46	19.83	19.64		
10	50	0		19.48	19.40	19.50		
Limit	EIRP < 2W			Result			Pass	



LTE Band 2 Maximum Average Power [dBm] (GT - LC = -0.8 dB)								
BW [MHz]	RB Size	RB Offset	Mod	Lowest	Middle	Highest	EIRP (dBm)	EIRP (W)
5	1	0	QPSK	22.32	22.57	22.59	21.79	0.1510
5	1	12		22.43	22.54	22.26		
5	1	24		22.53	22.49	22.43		
5	12	0		21.52	21.56	21.70		
5	12	7		21.62	21.69	21.67		
5	12	13		21.75	21.47	21.60		
5	25	0		21.39	21.67	21.54		
5	1	0	16-QAM	21.61	21.88	21.94	21.14	0.1300
5	1	12		21.90	21.70	21.75		
5	1	24		21.87	21.90	21.92		
5	12	0		20.51	20.46	20.58		
5	12	7		20.57	20.72	20.52		
5	12	13		20.70	20.73	20.53		
5	25	0		20.55	20.46	20.53		
5	1	0	64-QAM	20.69	20.75	20.81	20.01	0.1002
5	1	12		20.39	20.77	20.58		
5	1	24		20.44	20.52	20.57		
5	12	0		19.71	19.59	19.47		
5	12	7		19.68	19.52	19.78		
5	12	13		19.57	19.57	19.49		
5	25	0		19.65	19.61	19.49		
Limit	EIRP < 2W			Result			Pass	



LTE Band 2 Maximum Average Power [dBm] (GT - LC = -0.8 dB)								
BW [MHz]	RB Size	RB Offset	Mod	Lowest	Middle	Highest	EIRP (dBm)	EIRP (W)
3	1	0	QPSK	22.57	22.32	22.47	21.77	0.1503
3	1	8		22.35	22.45	22.53		
3	1	14		22.39	22.33	22.36		
3	8	0		21.52	21.73	21.48		
3	8	4		21.49	21.77	21.40		
3	8	7		21.57	21.75	21.48		
3	15	0		21.49	21.37	21.67		
3	1	0	16-QAM	21.68	22.10	21.67	21.30	0.1349
3	1	8		21.65	22.02	21.72		
3	1	14		21.95	21.69	21.77		
3	8	0		20.37	20.54	20.77		
3	8	4		20.52	20.57	20.40		
3	8	7		20.57	20.74	20.64		
3	15	0		20.76	20.54	20.42		
3	1	0	64-QAM	20.73	20.44	20.66	19.98	0.0995
3	1	8		20.31	20.78	20.59		
3	1	14		20.66	20.62	20.49		
3	8	0		19.58	19.51	19.52		
3	8	4		19.43	19.44	19.81		
3	8	7		19.53	19.59	19.51		
3	15	0		19.54	19.44	19.77		
Limit	EIRP < 2W			Result			Pass	



LTE Band 2 Maximum Average Power [dBm] (GT - LC = -0.8 dB)								
BW [MHz]	RB Size	RB Offset	Mod	Lowest	Middle	Highest	EIRP (dBm)	EIRP (W)
1.4	1	0	QPSK	22.34	22.63	22.53	21.87	0.1538
1.4	1	3		22.51	22.51	22.55		
1.4	1	5		22.52	22.55	22.21		
1.4	3	0		22.59	22.59	22.67		
1.4	3	1		22.66	22.47	22.36		
1.4	3	3		22.49	22.54	22.56		
1.4	6	0		21.60	21.65	21.66		
1.4	1	0	16-QAM	21.88	21.83	21.72	21.14	0.1300
1.4	1	3		21.84	21.90	21.67		
1.4	1	5		21.94	21.87	21.94		
1.4	3	0		21.72	21.84	21.43		
1.4	3	1		21.60	21.54	21.74		
1.4	3	3		21.58	21.66	21.59		
1.4	6	0		20.78	20.83	20.59		
1.4	1	0	64-QAM	20.49	20.85	20.69	20.12	0.1028
1.4	1	3		20.41	20.91	20.91		
1.4	1	5		20.30	20.60	20.80		
1.4	3	0		20.58	20.92	20.85		
1.4	3	1		20.15	20.70	20.57		
1.4	3	3		20.36	20.90	20.42		
1.4	6	0		19.33	19.55	19.65		
Limit	EIRP < 2W			Result			Pass	



LTE Band 5 Maximum Average Power [dBm] (GT - LC = -5.35 dB)								
BW [MHz]	RB Size	RB Offset	Mod	Lowest	Middle	Highest	ERP (dBm)	ERP (W)
10	1	0	QPSK	22.92	23.21	22.84	15.71	0.0372
10	1	25		23.07	22.94	23.05		
10	1	49		22.79	23.02	22.80		
10	25	0		22.04	22.01	22.12		
10	25	12		22.09	22.25	22.14		
10	25	25		21.97	22.25	21.91		
10	50	0		22.05	22.06	21.93		
10	1	0	16-QAM	22.23	22.39	22.48	14.98	0.0315
10	1	25		22.29	22.10	22.24		
10	1	49		22.47	22.46	22.38		
10	25	0		21.04	21.14	20.89		
10	25	12		21.08	21.23	21.25		
10	25	25		21.09	21.10	20.96		
10	50	0		21.24	20.93	21.08		
10	1	0	64-QAM	21.19	21.03	21.15	13.77	0.0238
10	1	25		21.18	21.26	21.27		
10	1	49		21.03	21.14	21.19		
10	25	0		20.34	20.21	19.98		
10	25	12		20.32	19.94	19.90		
10	25	25		20.11	20.27	20.09		
10	50	0		20.38	20.19	19.95		
Limit	ERP < 7W			Result			Pass	



LTE Band 5 Maximum Average Power [dBm] (GT - LC = -5.35 dB)								
BW [MHz]	RB Size	RB Offset	Mod	Lowest	Middle	Highest	ERP (dBm)	ERP (W)
5	1	0	QPSK	22.91	23.21	22.96	15.71	0.0372
5	1	12		23.21	22.81	22.70		
5	1	24		22.89	23.02	22.69		
5	12	0		21.99	21.99	21.92		
5	12	7		22.16	22.21	21.78		
5	12	13		21.98	21.96	21.97		
5	25	0		22.19	22.01	21.92		
5	1	0	16-QAM	22.53	22.48	22.44	15.03	0.0318
5	1	12		22.42	22.26	22.33		
5	1	24		22.35	22.40	21.99		
5	12	0		21.33	21.20	20.79		
5	12	7		21.04	21.18	21.01		
5	12	13		21.31	21.11	20.85		
5	25	0		21.28	20.90	20.72		
5	1	0	64-QAM	21.48	21.01	20.98	13.98	0.0250
5	1	12		21.18	21.34	21.07		
5	1	24		21.15	21.41	20.91		
5	12	0		20.29	20.16	20.01		
5	12	7		20.02	20.23	19.91		
5	12	13		19.97	20.19	20.05		
5	25	0		20.30	20.03	19.93		
Limit	ERP < 7W			Result			Pass	



LTE Band 5 Maximum Average Power [dBm] (GT - LC = -5.35 dB)								
BW [MHz]	RB Size	RB Offset	Mod	Lowest	Middle	Highest	ERP (dBm)	ERP (W)
3	1	0	QPSK	22.93	23.09	22.74	15.59	0.0362
3	1	8		23.01	22.95	22.84		
3	1	14		22.98	22.97	22.82		
3	8	0		22.08	21.89	21.92		
3	8	4		22.10	22.27	21.82		
3	8	7		22.28	22.12	21.81		
3	15	0		22.02	21.84	21.89		
3	1	0	16-QAM	22.49	22.13	22.29	14.99	0.0316
3	1	8		22.45	22.25	22.25		
3	1	14		22.25	22.11	22.10		
3	8	0		21.08	21.03	20.88		
3	8	4		21.16	21.10	21.19		
3	8	7		21.03	21.07	20.93		
3	15	0		21.16	21.08	20.94		
3	1	0	64-QAM	21.36	21.29	21.10	13.87	0.0244
3	1	8		21.33	21.15	21.13		
3	1	14		21.08	21.37	21.31		
3	8	0		20.14	20.09	20.03		
3	8	4		20.21	20.16	20.01		
3	8	7		20.09	19.95	19.98		
3	15	0		20.11	20.16	20.19		
Limit	ERP < 7W			Result			Pass	



LTE Band 5 Maximum Average Power [dBm] (GT - LC = -5.35 dB)								
BW [MHz]	RB Size	RB Offset	Mod	Lowest	Middle	Highest	ERP (dBm)	ERP (W)
1.4	1	0	QPSK	23.04	22.96	22.96	15.63	0.0366
1.4	1	3		23.08	22.78	22.78		
1.4	1	5		22.76	23.00	22.93		
1.4	3	0		23.13	23.06	22.66		
1.4	3	1		22.95	23.11	22.93		
1.4	3	3		22.87	22.94	22.76		
1.4	6	0		22.14	22.06	21.80		
1.4	1	0	16-QAM	22.26	22.37	22.29	15.05	0.0320
1.4	1	3		22.55	22.29	22.38		
1.4	1	5		22.28	22.29	22.24		
1.4	3	0		21.96	22.00	21.77		
1.4	3	1		21.96	22.08	21.97		
1.4	3	3		22.06	22.13	22.05		
1.4	6	0		21.07	20.91	20.83		
1.4	1	0	64-QAM	21.21	20.91	21.10	13.81	0.0240
1.4	1	3		21.24	21.11	21.07		
1.4	1	5		21.30	21.08	21.02		
1.4	3	0		21.26	20.95	20.98		
1.4	3	1		21.31	20.99	20.96		
1.4	3	3		21.21	21.18	20.95		
1.4	6	0		19.99	19.83	19.79		
Limit	ERP < 7W			Result			Pass	



LTE Band 7 Maximum Average Power [dBm] (GT - LC = -2.84 dB)								
BW [MHz]	RB Size	RB Offset	Mod	Lowest	Middle	Highest	EIRP (dBm)	EIRP (W)
20	1	0	QPSK	22.52	22.39	22.58	19.74	0.0942
20	1	49		22.31	22.40	22.28		
20	1	99		22.40	22.43	22.32		
20	50	0		21.55	21.49	21.34		
20	50	24		21.53	21.47	21.40		
20	50	50		21.35	21.34	21.68		
20	100	0		21.37	21.60	21.47		
20	1	0	16-QAM	21.60	21.46	21.60	18.99	0.0793
20	1	49		21.59	21.58	21.47		
20	1	99		21.76	21.83	21.62		
20	50	0		20.39	20.49	20.30		
20	50	24		20.37	20.38	20.24		
20	50	50		20.59	20.52	20.39		
20	100	0		20.54	20.28	20.45		
20	1	0	64-QAM	20.72	20.23	20.31	17.89	0.0615
20	1	49		20.73	20.47	20.66		
20	1	99		20.41	20.68	20.56		
20	50	0		19.49	19.23	19.45		
20	50	24		19.49	19.59	19.39		
20	50	50		19.53	19.46	19.48		
20	100	0		19.70	19.36	19.32		
Limit	EIRP < 2W			Result			Pass	



LTE Band 7 Maximum Average Power [dBm] (GT - LC = -2.84 dB)								
BW [MHz]	RB Size	RB Offset	Mod	Lowest	Middle	Highest	EIRP (dBm)	EIRP (W)
15	1	0	QPSK	22.31	22.29	22.25	19.63	0.0918
15	1	37		22.39	22.20	22.13		
15	1	74		22.47	22.31	22.40		
15	36	0		21.43	21.15	21.52		
15	36	20		21.44	21.51	21.34		
15	36	39		21.62	21.45	21.28		
15	75	0		21.34	21.43	21.41		
15	1	0	16-QAM	21.70	21.55	21.63	19.04	0.0802
15	1	37		21.53	21.47	21.39		
15	1	74		21.61	21.60	21.88		
15	36	0		20.47	20.20	20.56		
15	36	20		20.30	20.39	20.48		
15	36	39		20.22	20.49	20.34		
15	75	0		20.64	20.47	20.38		
15	1	0	64-QAM	20.53	20.57	20.33	17.81	0.0604
15	1	37		20.42	20.47	20.60		
15	1	74		20.41	20.44	20.65		
15	36	0		19.53	19.58	19.16		
15	36	20		19.59	19.21	19.36		
15	36	39		19.42	19.63	19.51		
15	75	0		19.51	19.26	19.47		
Limit	EIRP < 2W			Result			Pass	



LTE Band 7 Maximum Average Power [dBm] (GT - LC = -2.84 dB)								
BW [MHz]	RB Size	RB Offset	Mod	Lowest	Middle	Highest	EIRP (dBm)	EIRP (W)
10	1	0	QPSK	22.44	22.58	22.39	19.74	0.0942
10	1	25		22.15	22.40	22.38		
10	1	49		22.49	22.47	22.44		
10	25	0		21.51	21.25	21.26		
10	25	12		21.61	21.31	21.43		
10	25	25		21.37	21.41	21.40		
10	50	0		21.46	21.30	21.30		
10	1	0	16-QAM	21.50	21.54	21.61	18.93	0.0782
10	1	25		21.75	21.61	21.77		
10	1	49		21.77	21.48	21.73		
10	25	0		20.29	20.30	20.26		
10	25	12		20.38	20.48	20.43		
10	25	25		20.39	20.57	20.26		
10	50	0		20.60	20.17	20.18		
10	1	0	64-QAM	20.55	20.30	20.27	17.86	0.0611
10	1	25		20.59	20.46	20.70		
10	1	49		20.44	20.35	20.29		
10	25	0		19.56	19.25	19.55		
10	25	12		19.25	19.22	19.44		
10	25	25		19.61	19.25	19.56		
10	50	0		19.46	19.32	19.19		
Limit	EIRP < 2W			Result			Pass	



LTE Band 7 Maximum Average Power [dBm] (GT - LC = -2.84 dB)								
BW [MHz]	RB Size	RB Offset	Mod	Lowest	Middle	Highest	EIRP (dBm)	EIRP (W)
5	1	0	QPSK	22.45	22.26	22.39	19.66	0.0925
5	1	12		22.33	22.50	22.42		
5	1	24		22.31	22.20	22.22		
5	12	0		21.31	21.40	21.35		
5	12	7		21.44	21.40	21.33		
5	12	13		21.56	21.63	21.34		
5	25	0		21.47	21.32	21.50		
5	1	0	16-QAM	21.54	21.54	21.33	18.94	0.0783
5	1	12		21.61	21.35	21.35		
5	1	24		21.78	21.52	21.71		
5	12	0		20.70	20.28	20.47		
5	12	7		20.66	20.44	20.49		
5	12	13		20.21	20.53	20.33		
5	25	0		20.41	20.41	20.50		
5	1	0	64-QAM	20.61	20.19	20.37	17.86	0.0611
5	1	12		20.69	20.57	20.63		
5	1	24		20.70	20.64	20.62		
5	12	0		19.46	19.16	19.34		
5	12	7		19.65	19.42	19.45		
5	12	13		19.31	19.36	19.43		
5	25	0		19.54	19.31	19.39		
Limit	EIRP < 2W			Result			Pass	



LTE Band 12 Maximum Average Power [dBm] (GT - LC = -4.84 dB)								
BW [MHz]	RB Size	RB Offset	Mod	Lowest	Middle	Highest	ERP (dBm)	ERP (W)
10	1	0	QPSK	22.56	22.70	22.42	15.71	0.0372
10	1	25		22.18	22.43	22.45		
10	1	49		22.41	22.49	22.46		
10	25	0		21.36	21.59	21.39		
10	25	12		21.54	21.44	21.38		
10	25	25		21.66	21.47	21.35		
10	50	0		21.42	21.50	21.38		
10	1	0	16-QAM	21.52	21.44	21.58	15.05	0.0320
10	1	25		21.50	21.66	21.89		
10	1	49		21.62	22.04	21.69		
10	25	0		20.29	20.35	20.43		
10	25	12		20.43	20.46	20.46		
10	25	25		20.44	20.44	20.52		
10	50	0		20.58	20.53	20.50		
10	1	0	64-QAM	20.22	20.29	20.32	13.72	0.0236
10	1	25		20.71	20.44	20.24		
10	1	49		20.50	20.19	20.66		
10	25	0		19.52	19.54	19.32		
10	25	12		19.38	19.40	19.33		
10	25	25		19.62	19.69	19.47		
10	50	0		19.38	19.41	19.35		
Limit	ERP < 3W			Result			Pass	



LTE Band 12 Maximum Average Power [dBm] (GT - LC = -4.84 dB)								
BW [MHz]	RB Size	RB Offset	Mod	Lowest	Middle	Highest	ERP (dBm)	ERP (W)
5	1	0	QPSK	22.21	22.26	22.58	15.6	0.0363
5	1	12		22.59	22.29	22.28		
5	1	24		22.36	22.46	22.46		
5	12	0		21.42	21.40	21.51		
5	12	7		21.61	21.71	21.58		
5	12	13		21.40	21.43	21.62		
5	25	0		21.63	21.33	21.64		
5	1	0	16-QAM	21.45	21.78	21.91	14.93	0.0311
5	1	12		21.61	21.86	21.86		
5	1	24		21.92	21.58	21.82		
5	12	0		20.22	20.50	20.57		
5	12	7		20.33	20.36	20.50		
5	12	13		20.31	20.27	20.46		
5	25	0		20.63	20.58	20.41		
5	1	0	64-QAM	20.18	20.48	20.16	13.77	0.0238
5	1	12		20.41	20.76	20.40		
5	1	24		20.67	20.68	20.46		
5	12	0		19.15	19.44	19.28		
5	12	7		19.36	19.61	19.39		
5	12	13		19.17	19.37	19.14		
5	25	0		19.42	19.42	19.45		
Limit	ERP < 3W			Result			Pass	



LTE Band 12 Maximum Average Power [dBm] (GT - LC = -4.84 dB)								
BW [MHz]	RB Size	RB Offset	Mod	Lowest	Middle	Highest	ERP (dBm)	ERP (W)
3	1	0	QPSK	22.17	22.23	22.48	15.51	0.0356
3	1	8		22.42	22.42	22.32		
3	1	14		22.26	22.50	22.45		
3	8	0		21.17	21.43	21.58		
3	8	4		21.60	21.42	21.51		
3	8	7		21.33	21.32	21.68		
3	15	0		21.52	21.36	21.59		
3	1	0	16-QAM	21.48	21.57	21.79	14.84	0.0305
3	1	8		21.73	21.63	21.73		
3	1	14		21.70	21.49	21.83		
3	8	0		20.22	20.27	20.29		
3	8	4		20.27	20.55	20.68		
3	8	7		20.39	20.59	20.45		
3	15	0		20.34	20.59	20.59		
3	1	0	64-QAM	20.14	20.52	20.45	13.78	0.0239
3	1	8		20.42	20.77	20.57		
3	1	14		20.22	20.43	20.73		
3	8	0		19.13	19.49	19.44		
3	8	4		19.50	19.38	19.45		
3	8	7		19.47	19.62	19.39		
3	15	0		19.21	19.66	19.29		
Limit	ERP < 3W			Result			Pass	



LTE Band 12 Maximum Average Power [dBm] (GT - LC = -4.84 dB)								
BW [MHz]	RB Size	RB Offset	Mod	Lowest	Middle	Highest	ERP (dBm)	ERP (W)
1.4	1	0	QPSK	22.36	22.29	22.37	15.51	0.0356
1.4	1	3		22.28	22.33	22.40		
1.4	1	5		22.50	22.44	22.49		
1.4	3	0		22.20	22.22	22.30		
1.4	3	1		22.42	22.45	22.41		
1.4	3	3		22.34	22.19	22.30		
1.4	6	0		21.43	21.16	21.30		
1.4	1	0	16-QAM	21.42	21.73	21.68	14.78	0.0301
1.4	1	3		21.66	21.77	21.60		
1.4	1	5		21.32	21.65	21.48		
1.4	3	0		21.30	21.32	21.67		
1.4	3	1		21.29	21.32	21.59		
1.4	3	3		21.22	21.25	21.36		
1.4	6	0		20.28	20.61	20.39		
1.4	1	0	64-QAM	20.29	20.42	20.40	13.74	0.0237
1.4	1	3		20.19	20.48	20.73		
1.4	1	5		20.47	20.51	20.65		
1.4	3	0		20.20	20.32	20.39		
1.4	3	1		20.11	20.53	20.46		
1.4	3	3		20.51	20.69	20.64		
1.4	6	0		19.27	19.26	19.16		
Limit	ERP < 3W			Result			Pass	



LTE Band 17 Maximum Average Power [dBm] (GT - LC = -4.84 dB)								
BW [MHz]	RB Size	RB Offset	Mod	Lowest	Middle	Highest	ERP (dBm)	ERP (W)
10	1	0	QPSK	22.19	22.27	22.23	15.68	0.0370
10	1	25		22.45	22.40	22.31		
10	1	49		22.64	22.65	22.67		
10	25	0		21.37	21.49	21.18		
10	25	12		21.62	21.50	21.56		
10	25	25		21.65	21.42	21.50		
10	50	0		21.50	21.28	21.44		
10	1	0	16-QAM	21.51	21.50	21.70	14.92	0.0310
10	1	25		21.60	21.83	21.91		
10	1	49		21.66	21.65	21.80		
10	25	0		20.31	20.57	20.36		
10	25	12		20.55	20.42	20.57		
10	25	25		20.61	20.34	20.47		
10	50	0		20.42	20.39	20.53		
10	1	0	64-QAM	20.35	20.61	20.35	13.7	0.0234
10	1	25		20.69	20.51	20.40		
10	1	49		20.56	20.60	20.68		
10	25	0		19.44	19.51	19.36		
10	25	12		19.58	19.65	19.47		
10	25	25		19.77	19.77	19.41		
10	50	0		19.42	19.37	19.46		
Limit	ERP < 3W			Result			Pass	



LTE Band 17 Maximum Average Power [dBm] (GT - LC = -4.84 dB)								
BW [MHz]	RB Size	RB Offset	Mod	Lowest	Middle	Highest	ERP (dBm)	ERP (W)
5	1	0	QPSK	22.36	22.18	22.52	15.58	0.0361
5	1	12		22.51	22.26	22.40		
5	1	24		22.50	22.57	22.51		
5	12	0		21.45	21.16	21.57		
5	12	7		21.44	21.42	21.37		
5	12	13		21.32	21.53	21.35		
5	25	0		21.43	21.22	21.48		
5	1	0	16-QAM	21.52	21.58	21.77	14.94	0.0312
5	1	12		21.68	21.84	21.85		
5	1	24		21.93	21.88	21.80		
5	12	0		20.21	20.40	20.20		
5	12	7		20.59	20.53	20.52		
5	12	13		20.30	20.63	20.51		
5	25	0		20.20	20.52	20.56		
5	1	0	64-QAM	20.60	20.44	20.51	13.66	0.0232
5	1	12		20.46	20.48	20.58		
5	1	24		20.65	20.46	20.61		
5	12	0		19.50	19.28	19.40		
5	12	7		19.44	19.44	19.37		
5	12	13		19.33	19.35	19.70		
5	25	0		19.54	19.46	19.43		
Limit	ERP < 3W			Result			Pass	



LTE Band 38 Maximum Average Power [dBm] (GT - LC = -3.21 dB)								
BW [MHz]	RB Size	RB Offset	Mod	Lowest	Middle	Highest	EIRP (dBm)	EIRP (W)
20	1	0	QPSK	22.56	22.64	22.71	19.59	0.0910
20	1	49		22.66	22.80	22.79		
20	1	99		22.65	22.74	22.75		
20	50	0		21.60	21.70	21.79		
20	50	24		21.74	21.76	21.81		
20	50	50		21.75	21.90	21.86		
20	100	0		21.70	21.79	21.78		
20	1	0	16-QAM	21.67	21.78	21.86	18.73	0.0746
20	1	49		21.76	21.86	21.94		
20	1	99		21.82	21.91	21.92		
20	50	0		20.62	20.73	20.79		
20	50	24		20.75	20.79	20.92		
20	50	50		20.73	20.84	20.88		
20	100	0		20.70	20.75	20.80		
20	1	0	64-QAM	20.51	20.54	20.54	17.42	0.0552
20	1	49		20.56	20.57	20.63		
20	1	99		20.59	20.58	20.62		
20	50	0		19.62	19.73	19.80		
20	50	24		19.75	19.81	19.93		
20	50	50		19.72	19.82	19.90		
20	100	0		19.72	19.73	19.81		
Limit	EIRP < 2W			Result			Pass	



LTE Band 38 Maximum Average Power [dBm] (GT - LC = -3.21 dB)								
BW [MHz]	RB Size	RB Offset	Mod	Lowest	Middle	Highest	EIRP (dBm)	EIRP (W)
15	1	0	QPSK	22.57	22.63	22.71	19.55	0.0902
15	1	37		22.58	22.76	22.73		
15	1	74		22.59	22.74	22.73		
15	36	0		21.53	21.61	21.72		
15	36	20		21.64	21.74	21.73		
15	36	39		21.70	21.85	21.82		
15	75	0		21.68	21.70	21.71		
15	1	0	16-QAM	21.65	21.71	21.79	18.73	0.0746
15	1	37		21.76	21.80	21.94		
15	1	74		21.79	21.90	21.86		
15	36	0		20.57	20.71	20.78		
15	36	20		20.69	20.77	20.90		
15	36	39		20.73	20.77	20.82		
15	75	0		20.60	20.73	20.71		
15	1	0	64-QAM	20.58	20.56	20.51	17.37	0.0546
15	1	37		20.57	20.53	20.53		
15	1	74		20.56	20.51	20.55		
15	36	0		19.55	19.66	19.72		
15	36	20		19.67	19.71	19.85		
15	36	39		19.71	19.82	19.83		
15	75	0		19.65	19.63	19.81		
Limit	EIRP < 2W			Result			Pass	



LTE Band 38 Maximum Average Power [dBm] (GT - LC = -3.21 dB)								
BW [MHz]	RB Size	RB Offset	Mod	Lowest	Middle	Highest	EIRP (dBm)	EIRP (W)
10	1	0	QPSK	22.56	22.64	22.66	19.55	0.0902
10	1	25		22.53	22.72	22.76		
10	1	49		22.62	22.70	22.65		
10	25	0		21.54	21.70	21.75		
10	25	12		21.65	21.72	21.72		
10	25	25		21.66	21.80	21.78		
10	50	0		21.67	21.77	21.71		
10	1	0	16-QAM	21.66	21.72	21.80	18.66	0.0735
10	1	25		21.71	21.82	21.86		
10	1	49		21.75	21.87	21.82		
10	25	0		20.57	20.65	20.77		
10	25	12		20.72	20.77	20.90		
10	25	25		20.63	20.84	20.85		
10	50	0		20.63	20.65	20.72		
10	1	0	64-QAM	20.56	20.51	20.57	17.39	0.0548
10	1	25		20.58	20.57	20.56		
10	1	49		20.57	20.55	20.60		
10	25	0		19.54	19.71	19.71		
10	25	12		19.67	19.74	19.89		
10	25	25		19.71	19.76	19.82		
10	50	0		19.71	19.64	19.71		
Limit	EIRP < 2W			Result			Pass	



LTE Band 38 Maximum Average Power [dBm] (GT - LC = -3.21 dB)								
BW [MHz]	RB Size	RB Offset	Mod	Lowest	Middle	Highest	EIRP (dBm)	EIRP (W)
5	1	0	QPSK	22.57	22.57	22.67	19.57	0.0906
5	1	12		22.53	22.78	22.69		
5	1	24		22.57	22.71	22.69		
5	12	0		21.57	21.61	21.73		
5	12	7		21.65	21.68	21.76		
5	12	13		21.72	21.84	21.82		
5	25	0		21.66	21.70	21.68		
5	1	0	16-QAM	21.65	21.76	21.84	18.73	0.0746
5	1	12		21.76	21.86	21.94		
5	1	24		21.77	21.87	21.86		
5	12	0		20.57	20.64	20.77		
5	12	7		20.71	20.76	20.89		
5	12	13		20.70	20.77	20.83		
5	25	0		20.62	20.66	20.72		
5	1	0	64-QAM	20.54	20.57	20.54	17.39	0.0548
5	1	12		20.57	20.54	20.60		
5	1	24		20.50	20.50	20.59		
5	12	0		19.52	19.69	19.72		
5	12	7		19.73	19.71	19.91		
5	12	13		19.72	19.80	19.89		
5	25	0		19.65	19.72	19.77		
Limit	EIRP < 2W			Result			Pass	



LTE Band 38

Peak-to-Average Ratio

Mode	LTE Band 38 / 20MHz				
Mod.	QPSK	16QAM	64QAM	256QAM	Limit: 13dB
RB Size	Full RB	Full RB	Full RB	Full RB	Result
Middle CH	4.49	5.48	6.35	-	PASS



LTE Band 38 / 20MHz / QPSK

Middle Channel / Full RB

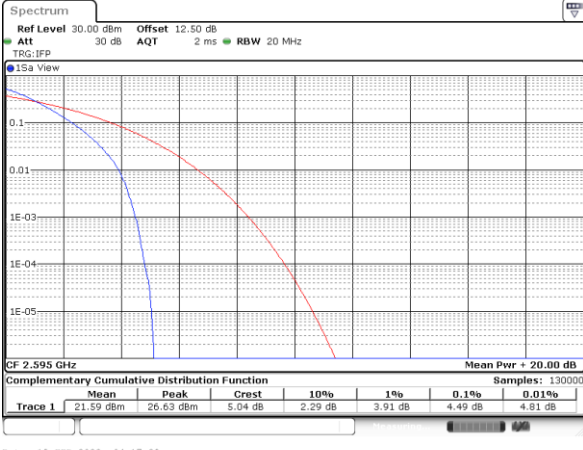

Date: 19.FEB.2022 04:17:29

LTE Band 38 / 20MHz / 16QAM

Middle Channel / Full RB

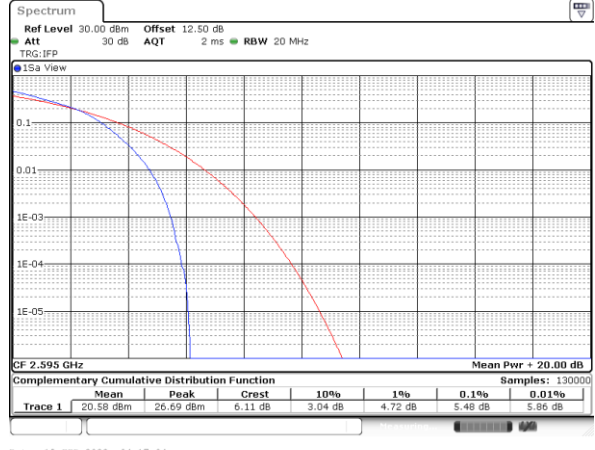

Date: 19.FEB.2022 04:17:04

LTE Band 38 / 20MHz / 64QAM

Middle Channel / Full RB

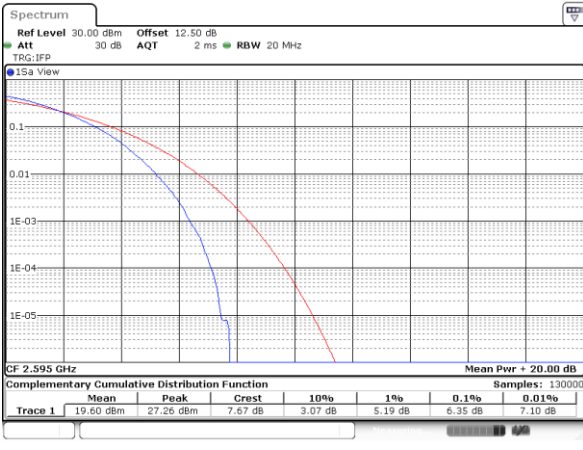

Date: 19.FEB.2022 04:16:38

LTE Band 38 / 20MHz / 256QAM

Middle Channel / Full RB

NA



26dB Bandwidth

Mode	LTE Band 38 : 26dB BW(MHz)											
BW	1.4MHz		3MHz		5MHz		10MHz		15MHz		20MHz	
Mod.	QPSK	16QAM	QPSK	16QAM	QPSK	16QAM	QPSK	16QAM	QPSK	16QAM	QPSK	16QAM
Middle CH	-	-	-	-	4.85	4.85	9.69	9.61	14.30	14.15	18.66	18.62
Mode	LTE Band 38 : 26dB BW(MHz)											
BW	1.4MHz		3MHz		5MHz		10MHz		15MHz		20MHz	
Mod.	64QAM	256 QAM	64QAM	256 QAM	64QAM	256 QAM	64QAM	256 QAM	64QAM	256 QAM	64QAM	256 QAM
Middle CH	-	-	-	-	4.87	-	9.69	-	14.09	-	18.70	-



LTE Band 38

Middle Channel / 5MHz / QPSK

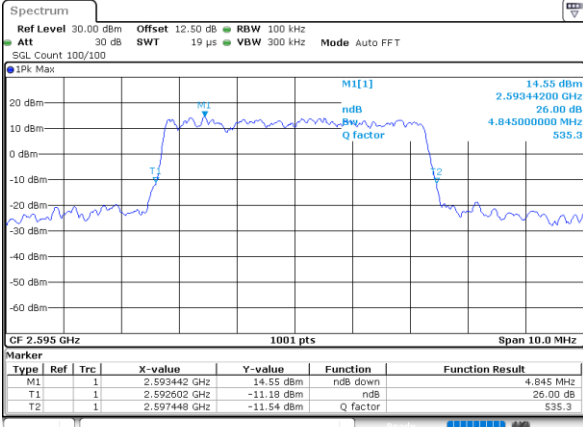

Date: 19.FEB.2022 03:54:07

Middle Channel / 5MHz / 16QAM

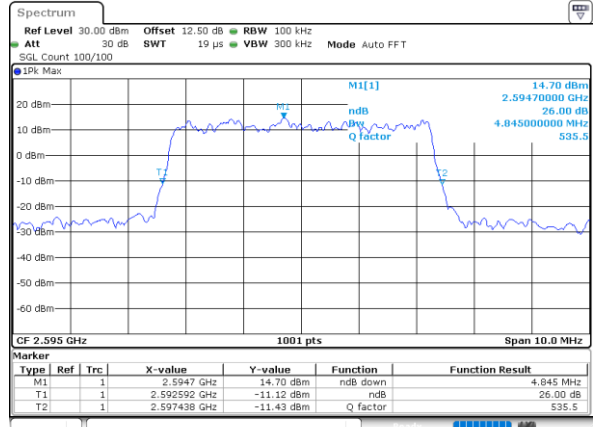

Date: 19.FEB.2022 04:13:27

Middle Channel / 10MHz / QPSK

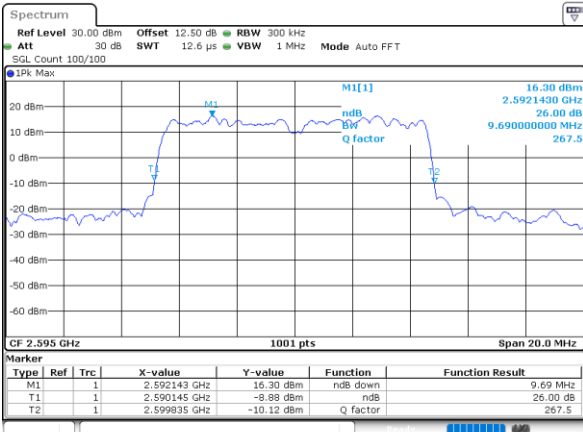

Date: 19.FEB.2022 03:55:43

Middle Channel / 10MHz / 16QAM

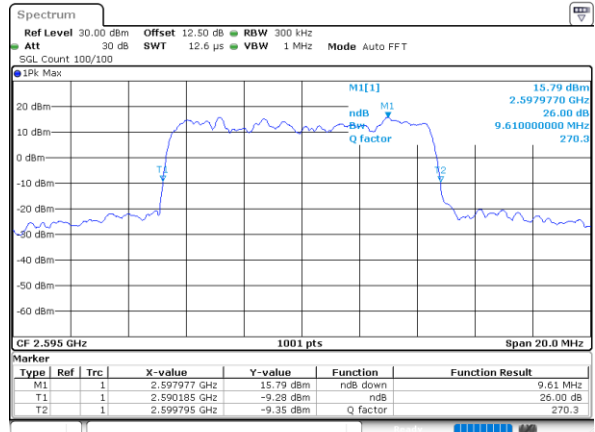

Date: 19.FEB.2022 03:56:07

Middle Channel / 15MHz / QPSK

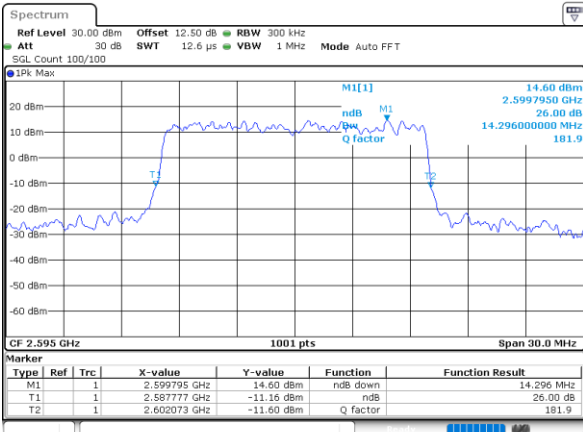

Date: 19.FEB.2022 03:57:19

Middle Channel / 15MHz / 16QAM

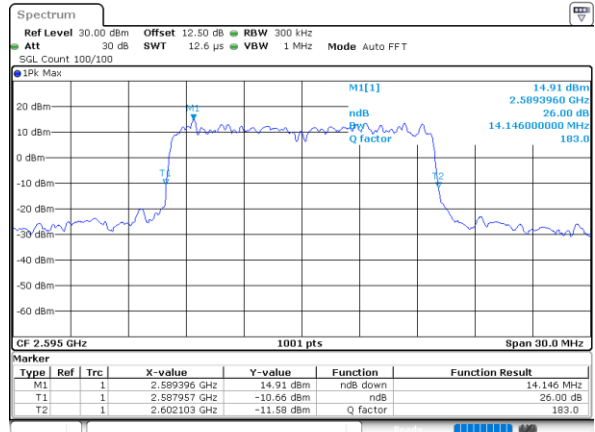

Date: 19.FEB.2022 03:57:43



LTE Band 38

Middle Channel / 20MHz / QPSK

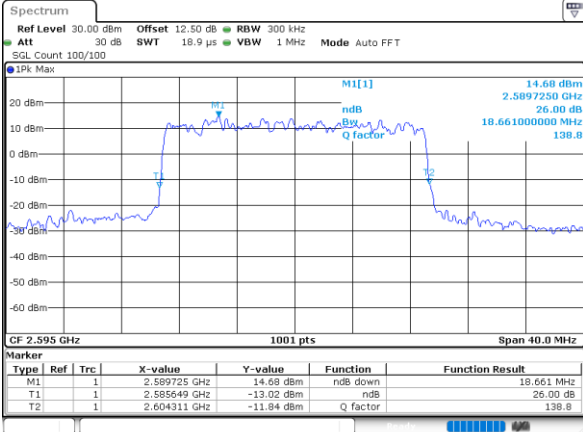

Date: 19.FEB.2022 03:58:55

Middle Channel / 20MHz / 16QAM

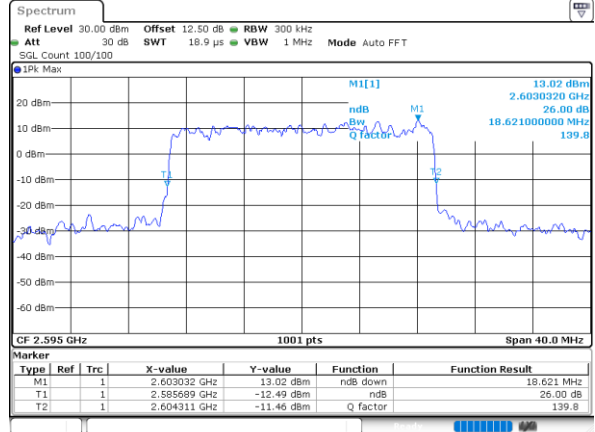

Date: 19.FEB.2022 03:59:19

Middle Channel / 5MHz / 64QAM

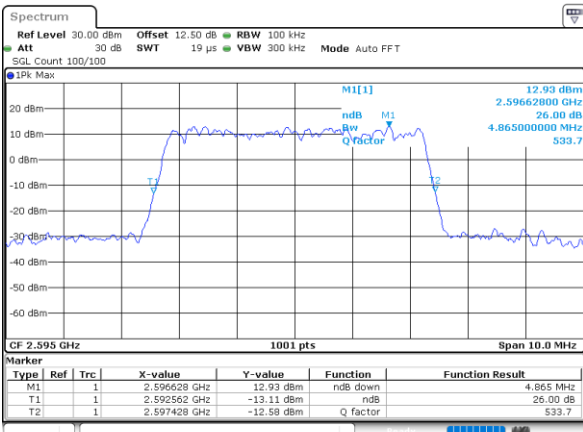

Date: 19.FEB.2022 04:00:08

Middle Channel / 10MHz / 64QAM

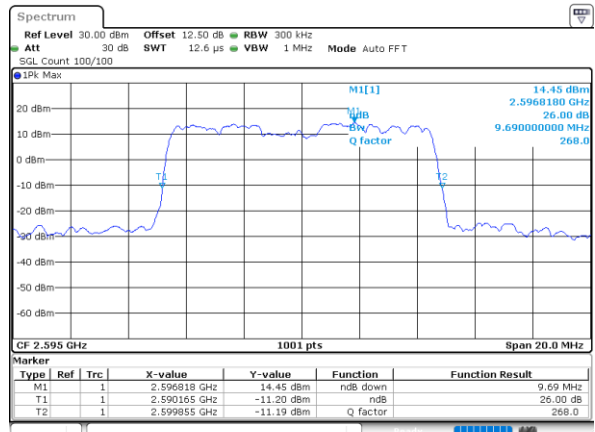

Date: 19.FEB.2022 04:00:56

Middle Channel / 15MHz / 64QAM

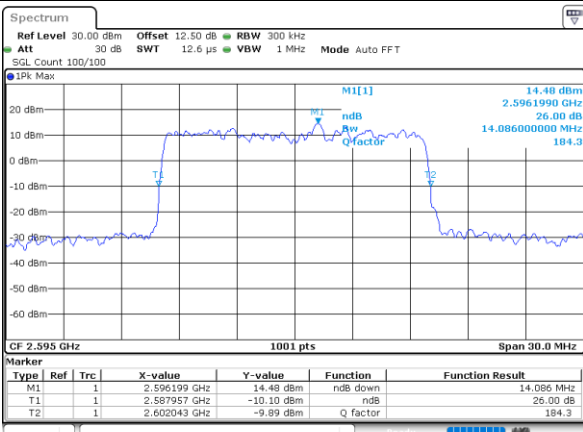

Date: 19.FEB.2022 04:01:45

Middle Channel / 20MHz / 64QAM

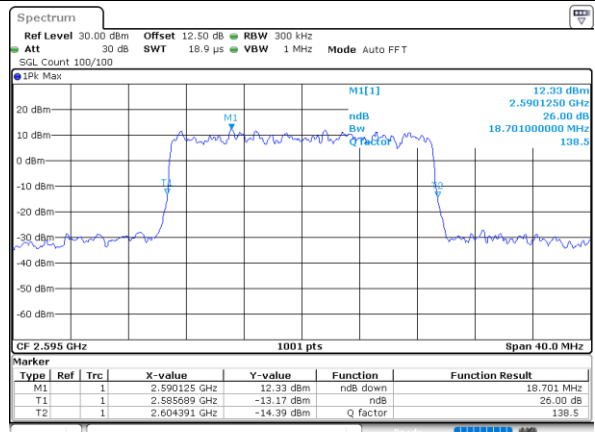

Date: 19.FEB.2022 04:02:34



Occupied Bandwidth

Mode	LTE Band 38 : 99%OBW(MHz)											
BW	1.4MHz		3MHz		5MHz		10MHz		15MHz		20MHz	
Mod.	QPSK	16QAM	QPSK	16QAM	QPSK	16QAM	QPSK	16QAM	QPSK	16QAM	QPSK	16QAM
Middle CH	-	-	-	-	4.48	4.49	9.05	8.99	13.46	13.55	17.98	17.82
Mode	LTE Band 38 : 99%OBW(MHz)											
BW	1.4MHz		3MHz		5MHz		10MHz		15MHz		20MHz	
Mod.	64QAM	256 QAM	64QAM	256 QAM	64QAM	256 QAM	64QAM	256 QAM	64QAM	256 QAM	64QAM	256 QAM
Middle CH	-	-	-	-	4.48	-	9.09	-	13.52	-	17.94	-



LTE Band 38

Middle Channel / 5MHz / QPSK

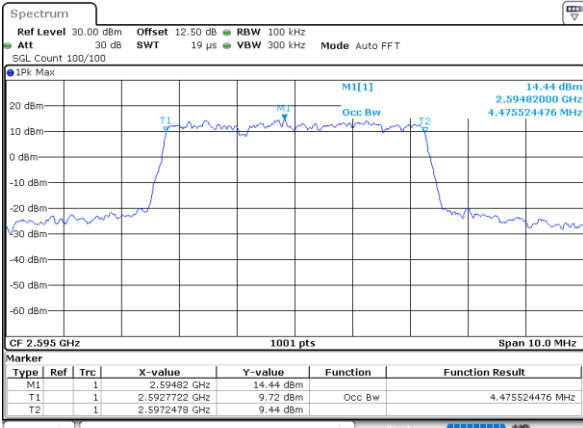

Date: 19.FEB.2022 03:53:20

Middle Channel / 5MHz / 16QAM

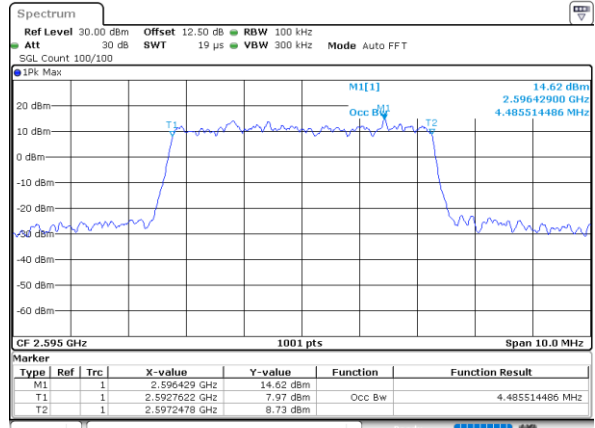

Date: 19.FEB.2022 03:53:44

Middle Channel / 10MHz / QPSK

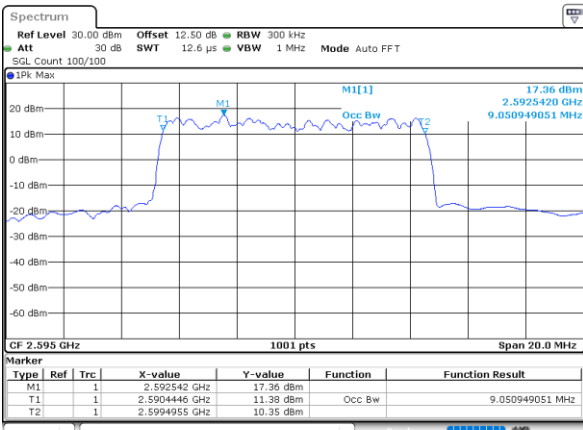

Date: 19.FEB.2022 03:54:06

Middle Channel / 10MHz / 16QAM

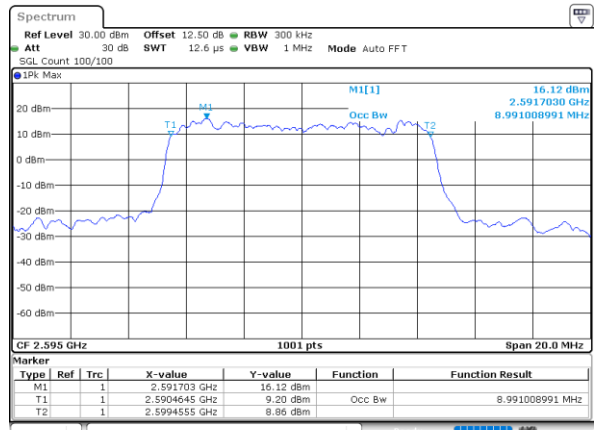

Date: 19.FEB.2022 03:55:20

Middle Channel / 15MHz / QPSK

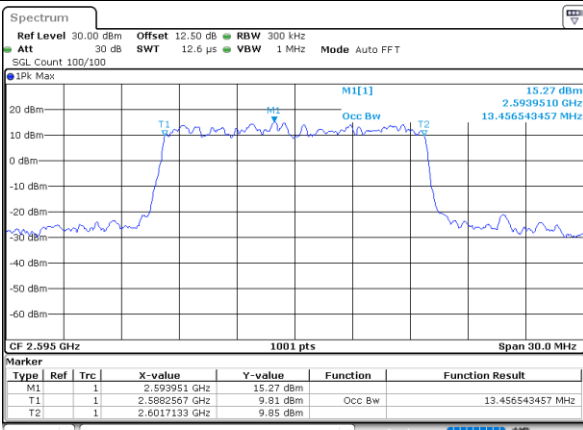

Date: 19.FEB.2022 03:56:32

Middle Channel / 15MHz / 16QAM

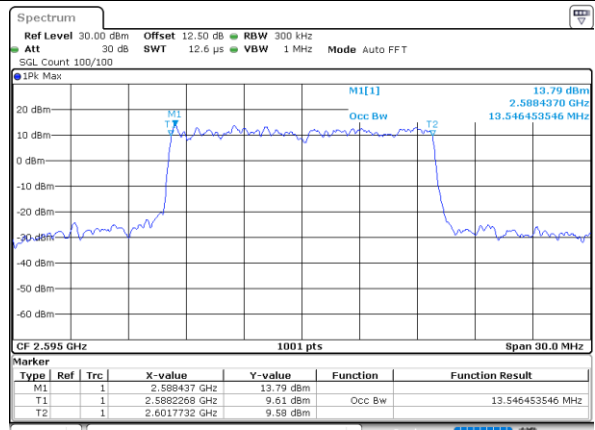

Date: 19.FEB.2022 03:56:55



LTE Band 38

Middle Channel / 20MHz / QPSK

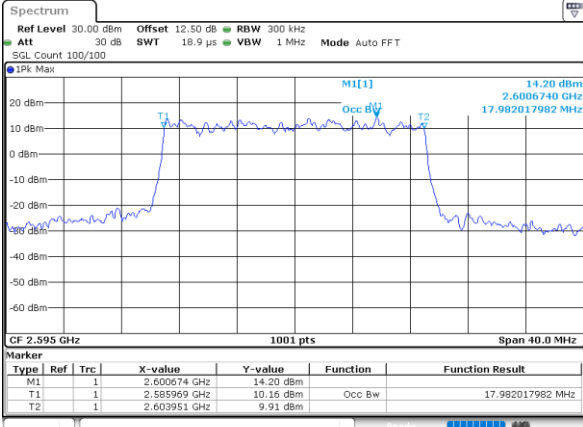

Date: 19.FEB.2022 03:58:08

Middle Channel / 20MHz / 16QAM

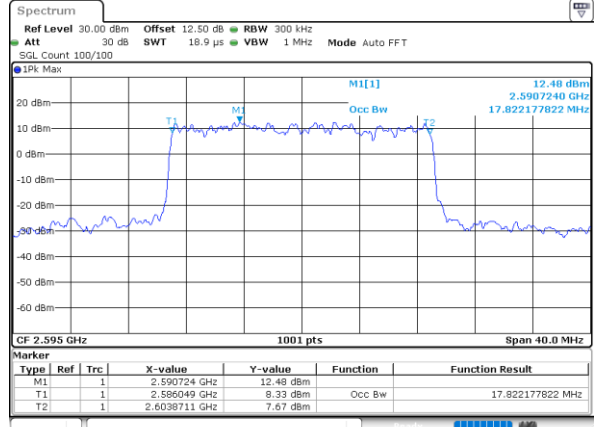

Date: 19.FEB.2022 03:58:132

Middle Channel / 5MHz / 64QAM

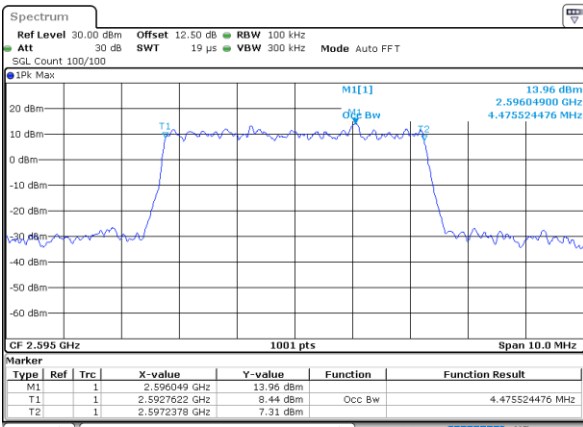

Date: 19.FEB.2022 03:59:44

Middle Channel / 10MHz / 64QAM

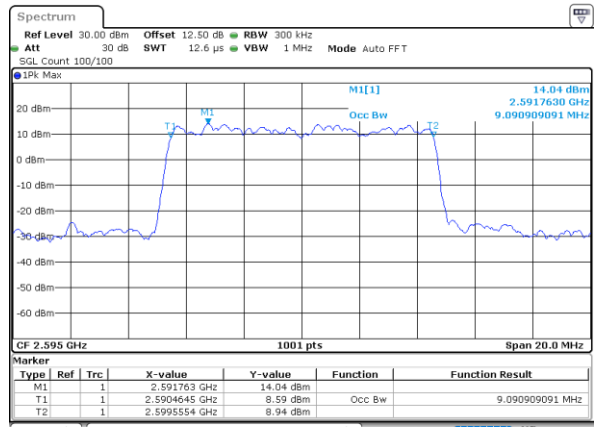

Date: 19.FEB.2022 04:00:133

Middle Channel / 15MHz / 64QAM

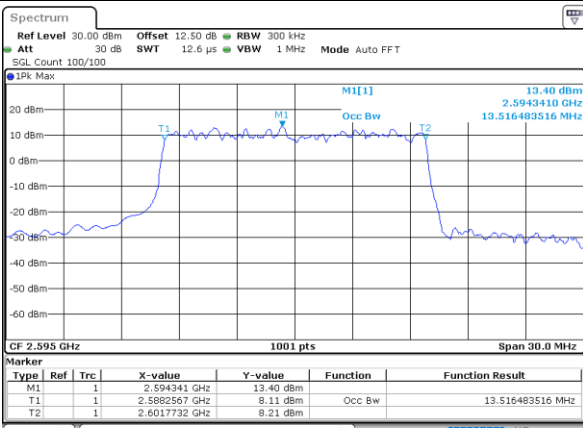

Date: 19.FEB.2022 04:01:22

Middle Channel / 20MHz / 64QAM

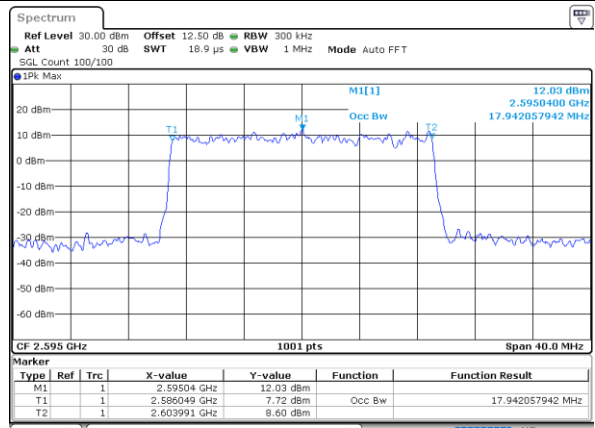

Date: 19.FEB.2022 04:02:10



Conducted Band Edge

LTE Band 38 / 5MHz / QPSK

Lowest Band Edge / 1 RB

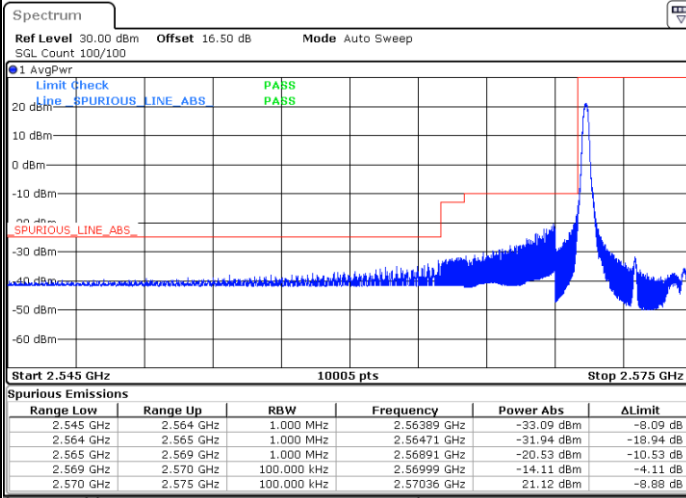

Date: 19.FEB.2022 02:52:01

Highest Band Edge / 1 RB

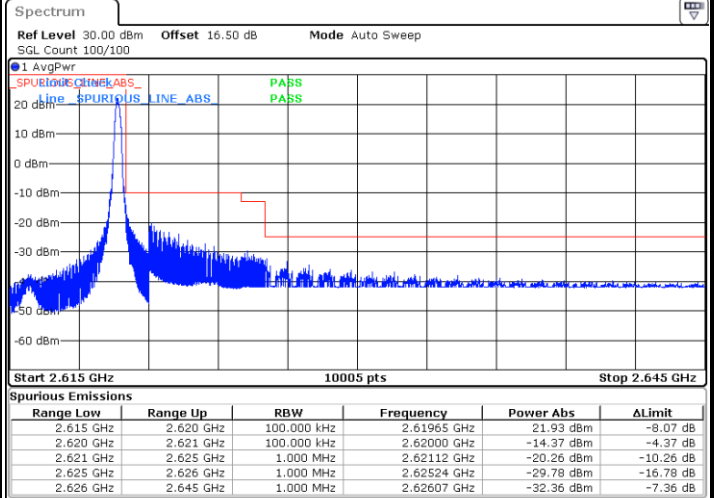

Date: 19.FEB.2022 02:57:27

Lowest Band Edge / Full RB

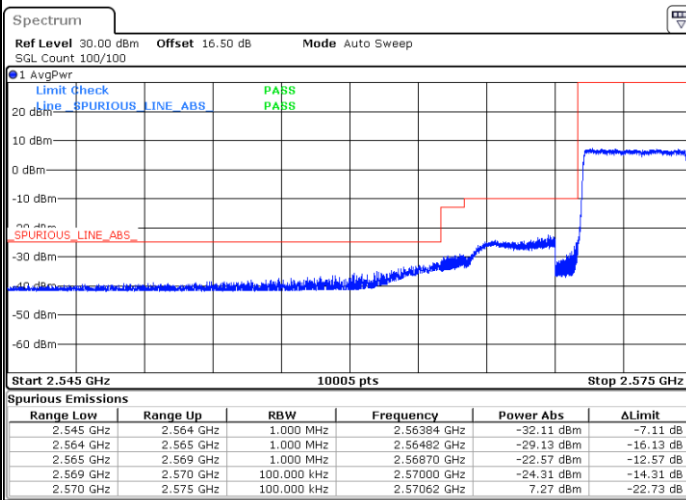

Date: 19.FEB.2022 02:53:49

Highest Band Edge / Full RB

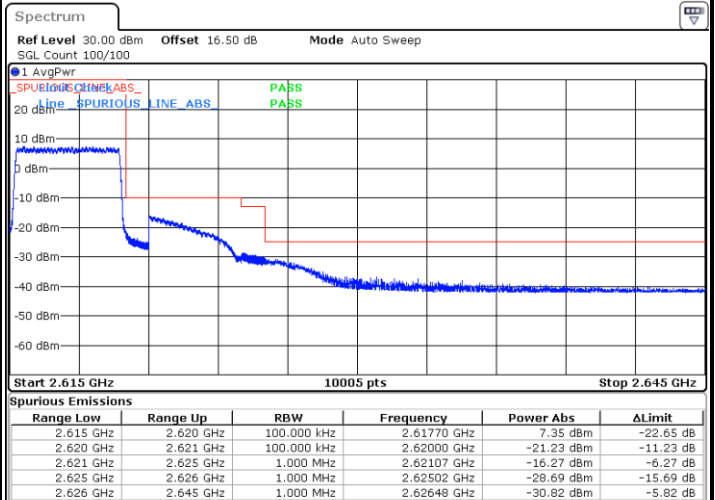

Date: 19.FEB.2022 02:55:39



LTE Band 38 / 5MHz / 16QAM

Lowest Band Edge / 1RB

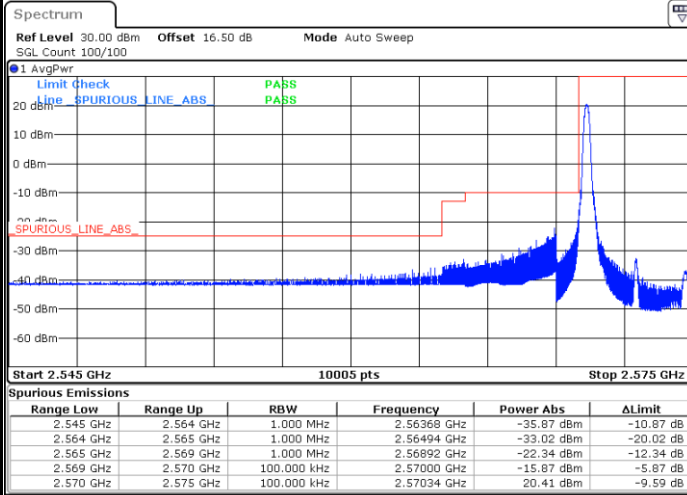

Date: 19.FEB.2022 02:52:55

Highest Band Edge / 1 RB

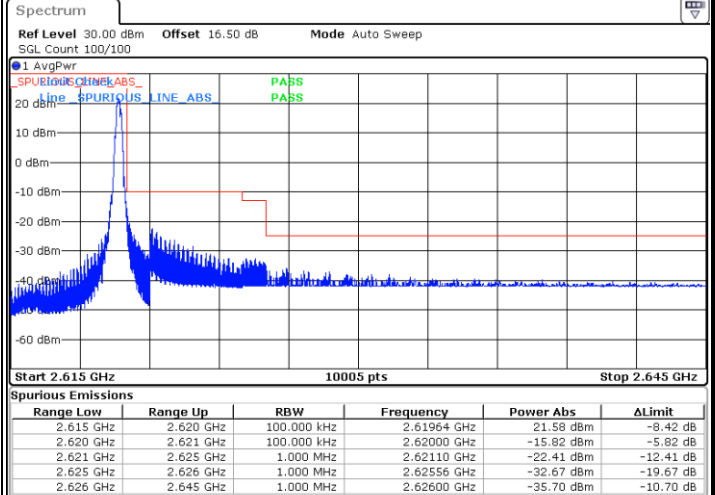

Date: 19.FEB.2022 02:58:22

Lowest Band Edge / Full RB

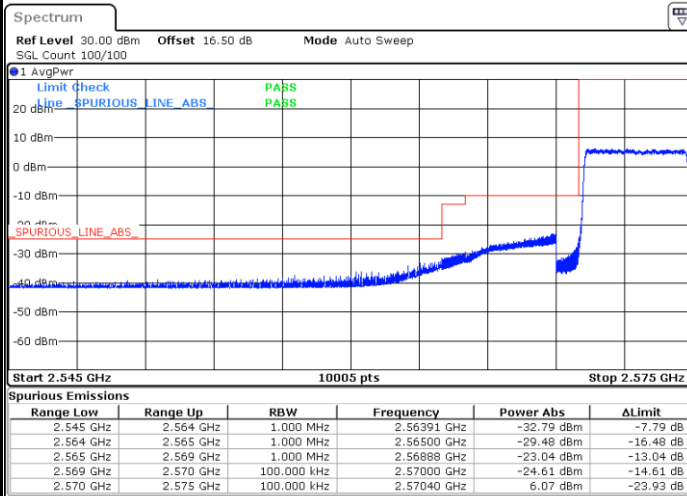

Date: 19.FEB.2022 02:54:44

Highest Band Edge / Full RB

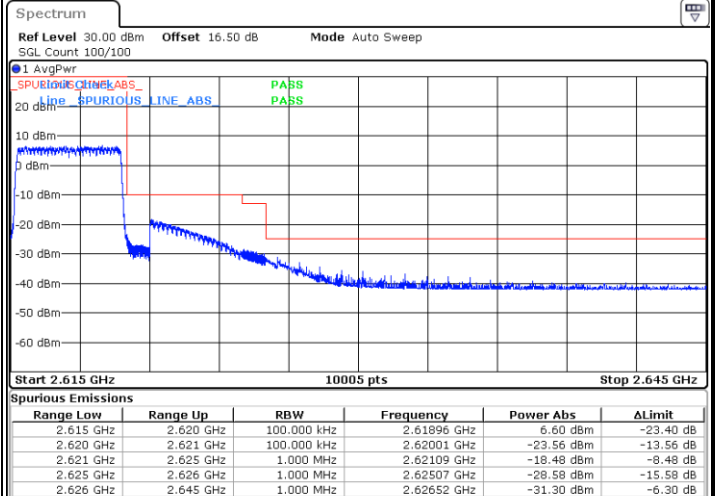

Date: 19.FEB.2022 02:56:33



LTE Band 38 / 5MHz / 64QAM

Lowest Band Edge / 1RB

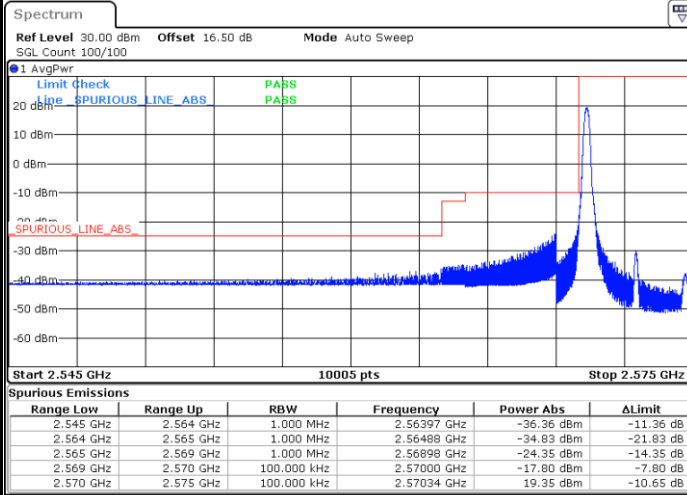

Date: 19.FEB.2022 02:59:16

Highest Band Edge / 1 RB

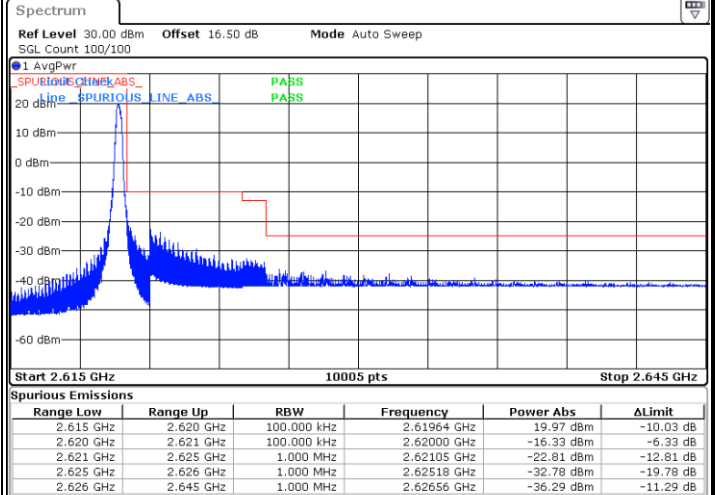

Date: 19.FEB.2022 03:01:59

Lowest Band Edge / Full RB

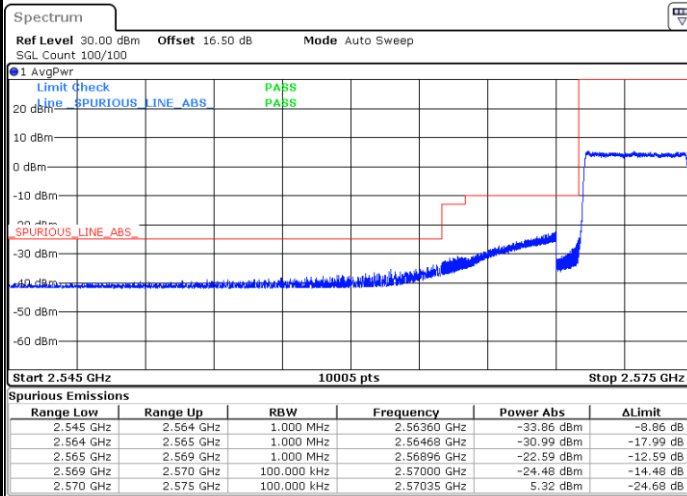

Date: 19.FEB.2022 03:00:11

Highest Band Edge / Full RB

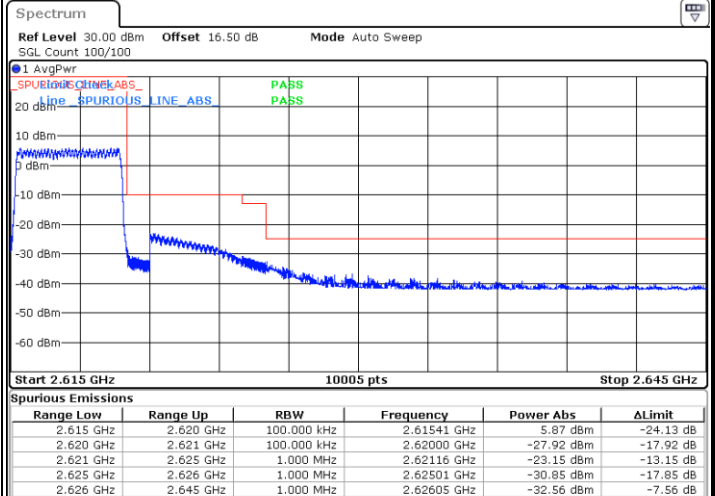

Date: 19.FEB.2022 03:01:05



LTE Band 38 / 10MHz / QPSK

Lowest Band Edge / 1 RB

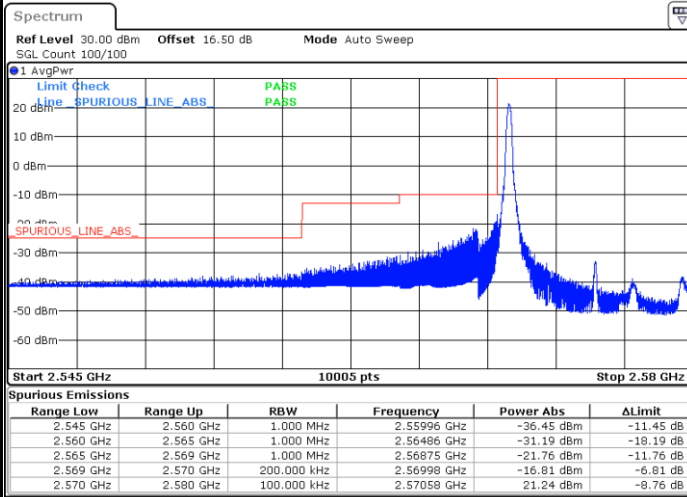

Date: 19.FEB.2022 03:06:34

Highest Band Edge / 1 RB

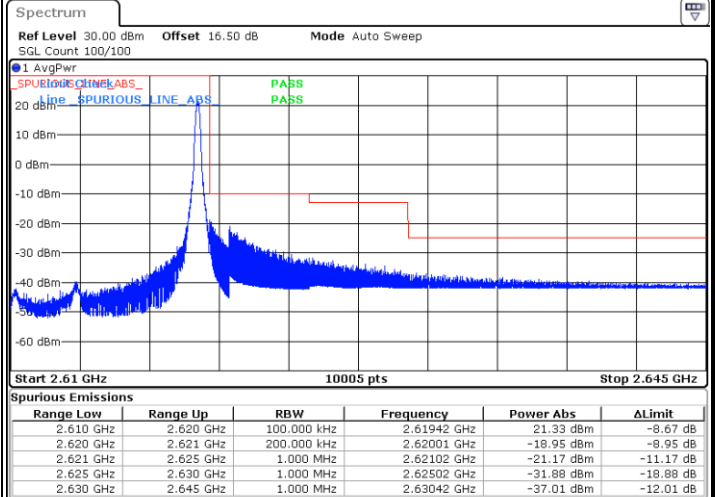

Date: 19.FEB.2022 03:12:01

Lowest Band Edge / Full RB

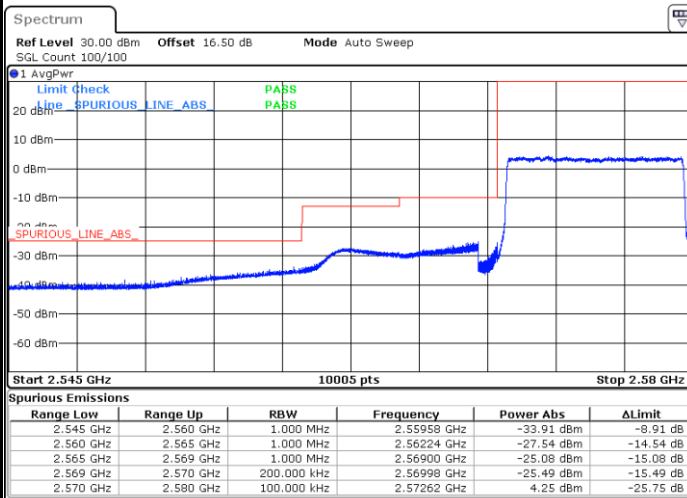

Date: 19.FEB.2022 03:08:23

Highest Band Edge / Full RB

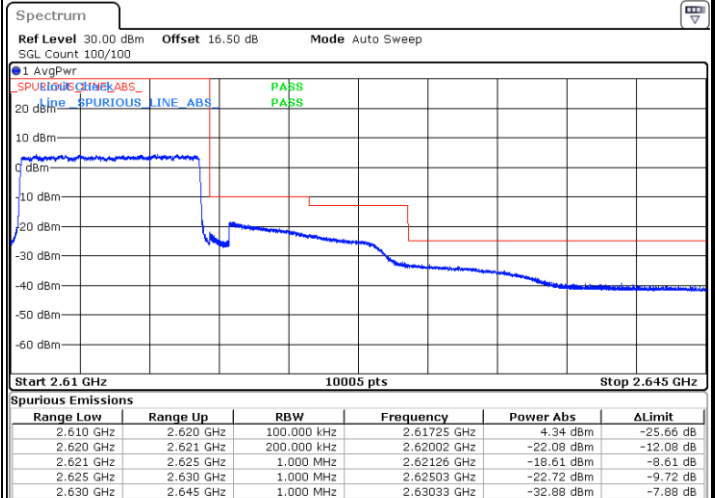

Date: 19.FEB.2022 03:10:12



LTE Band 38 / 10MHz / 16QAM

Lowest Band Edge / 1 RB

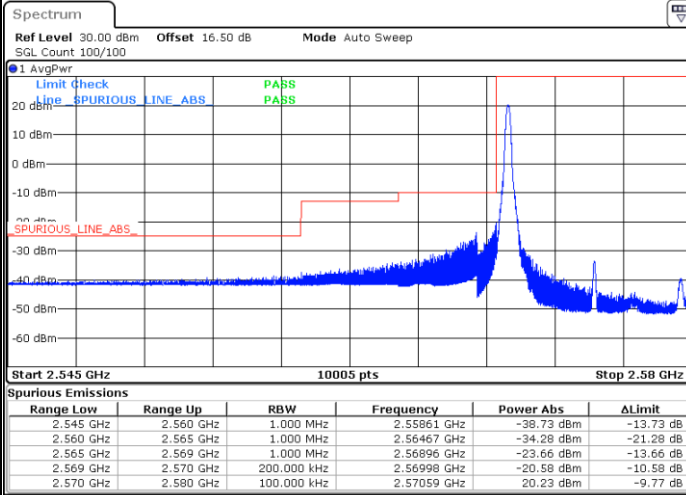

Date: 19.FEB.2022 03:07:29

Highest Band Edge / 1 RB

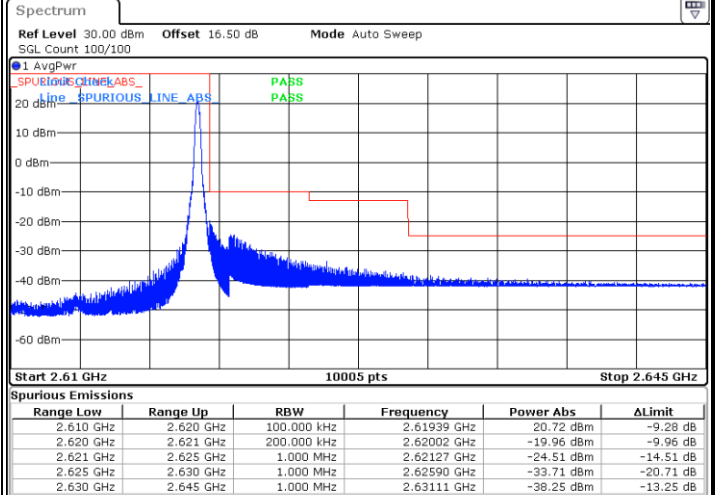

Date: 19.FEB.2022 03:12:56

Lowest Band Edge / Full RB

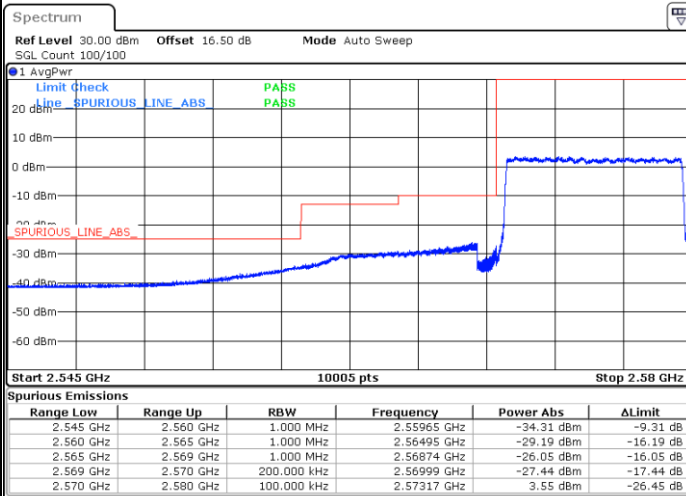

Date: 19.FEB.2022 03:09:17

Highest Band Edge / Full RB

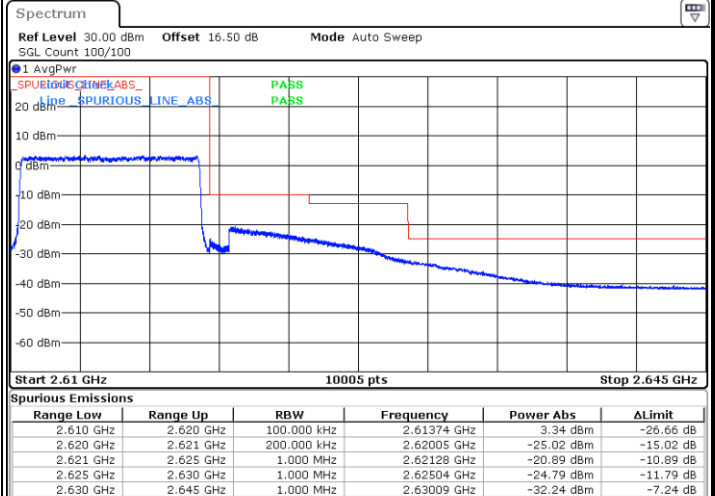

Date: 19.FEB.2022 03:11:06



LTE Band 38 / 10MHz / 64QAM

Lowest Band Edge / 1 RB

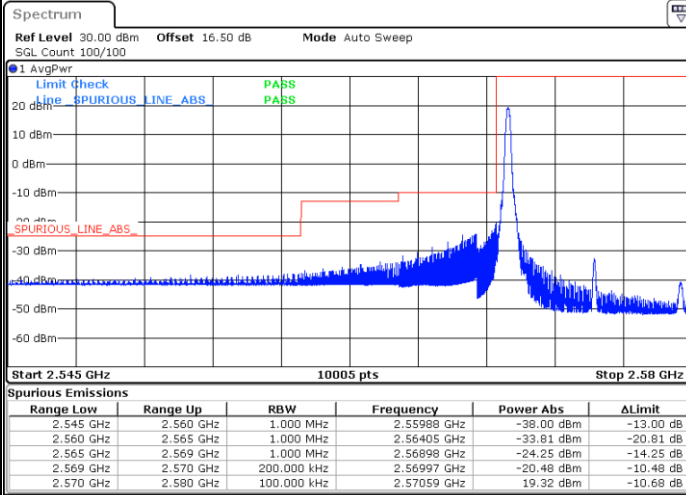

Date: 19.FEB.2022 03:02:55

Highest Band Edge / 1 RB

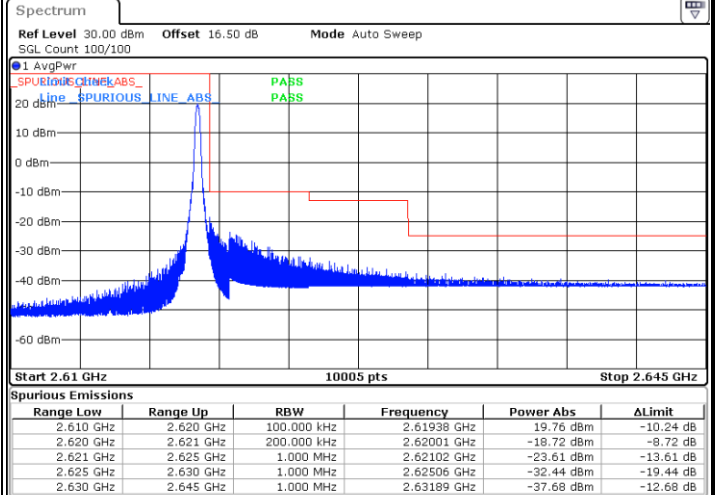

Date: 19.FEB.2022 03:05:40

Lowest Band Edge / Full RB

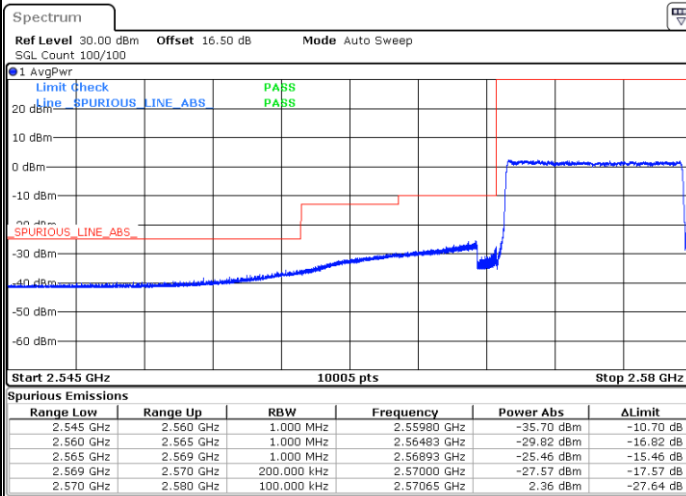

Date: 19.FEB.2022 03:03:50

Highest Band Edge / Full RB

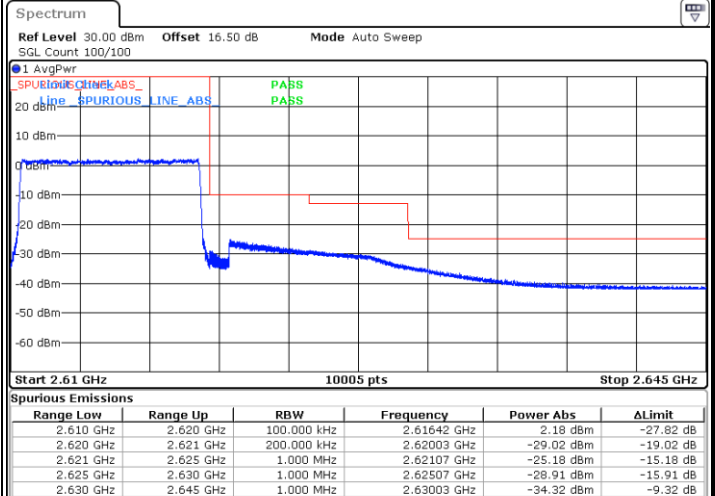

Date: 19.FEB.2022 03:04:45



LTE Band 38 / 15MHz / QPSK

Lowest Band Edge / 1 RB

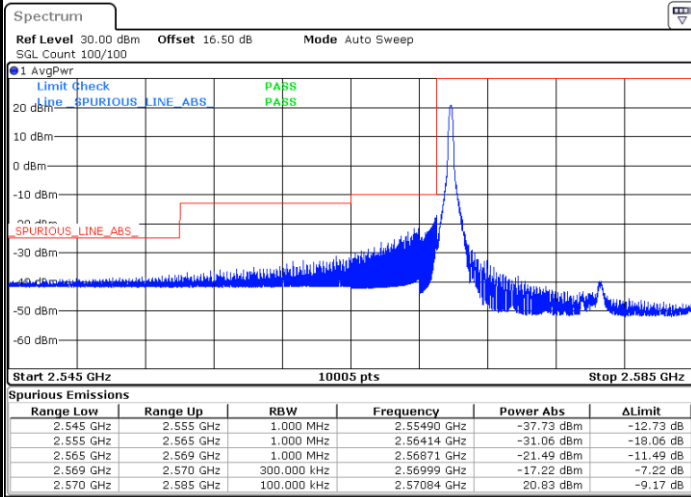

Date: 19.FEB.2022 03:13:52

Highest Band Edge / 1 RB

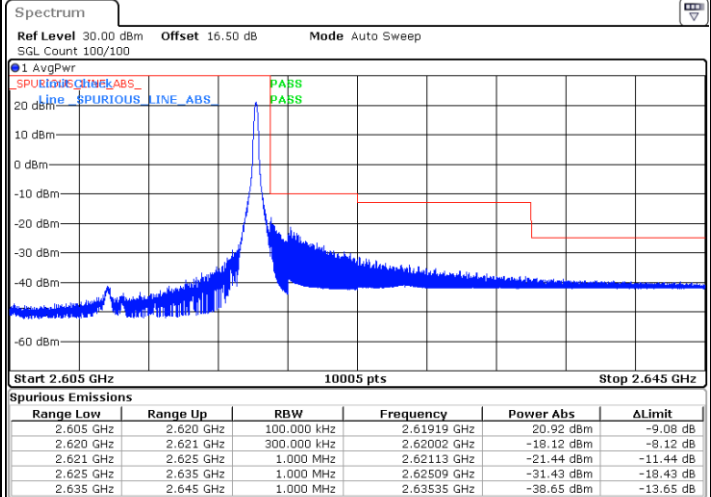

Date: 19.FEB.2022 03:19:21

Lowest Band Edge / Full RB

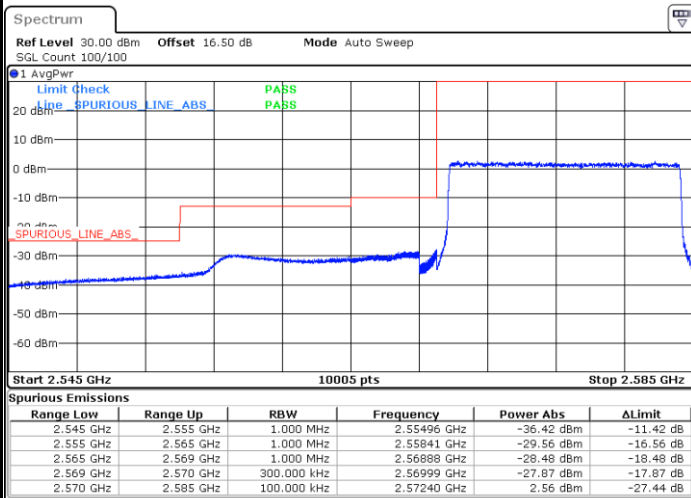

Date: 19.FEB.2022 03:15:41

Highest Band Edge / Full RB

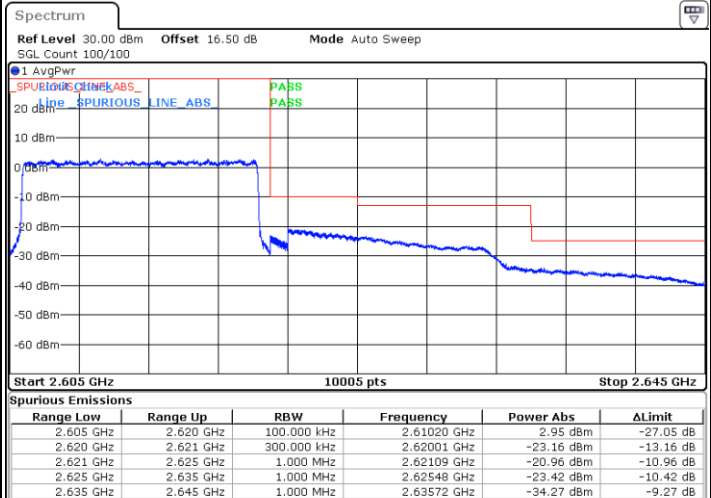

Date: 19.FEB.2022 03:17:30



LTE Band 38 / 15MHz / 16QAM

Lowest Band Edge / 1 RB

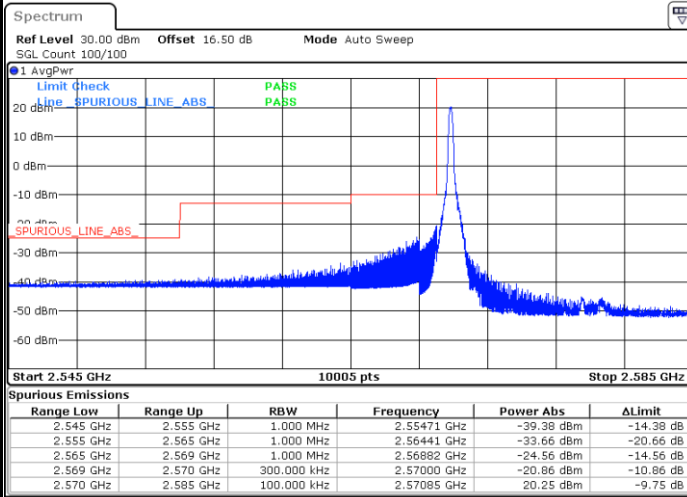

Date: 19.FEB.2022 03:14:46

Highest Band Edge / 1 RB

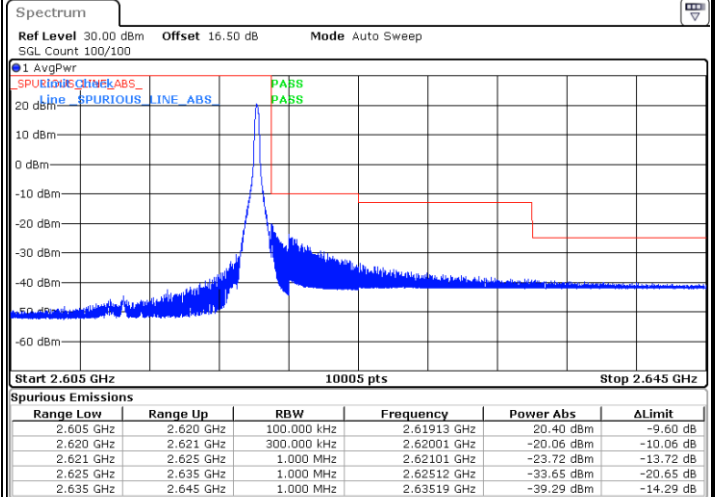

Date: 19.FEB.2022 03:20:16

Lowest Band Edge / Full RB

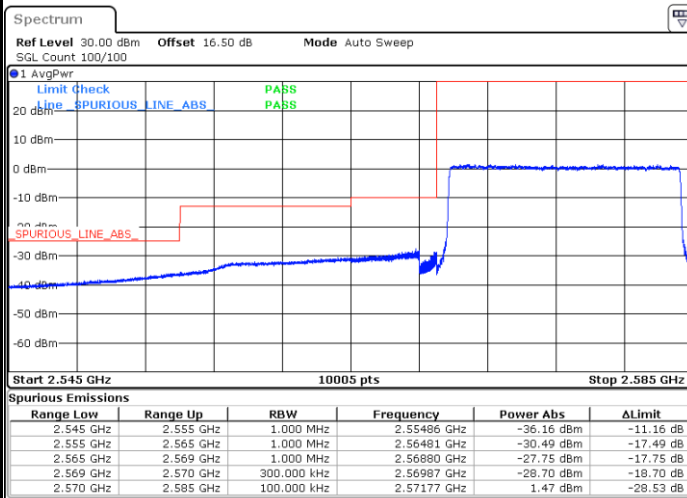

Date: 19.FEB.2022 03:16:35

Highest Band Edge / Full RB

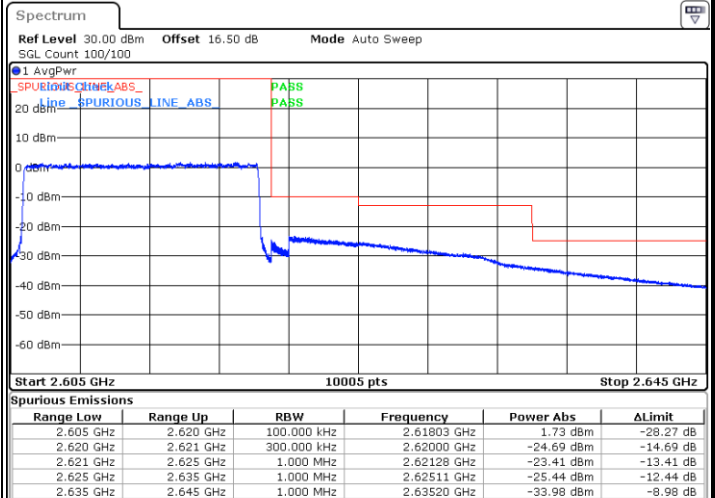

Date: 19.FEB.2022 03:18:25



LTE Band 38 / 15MHz / 64QAM

Lowest Band Edge / 1 RB

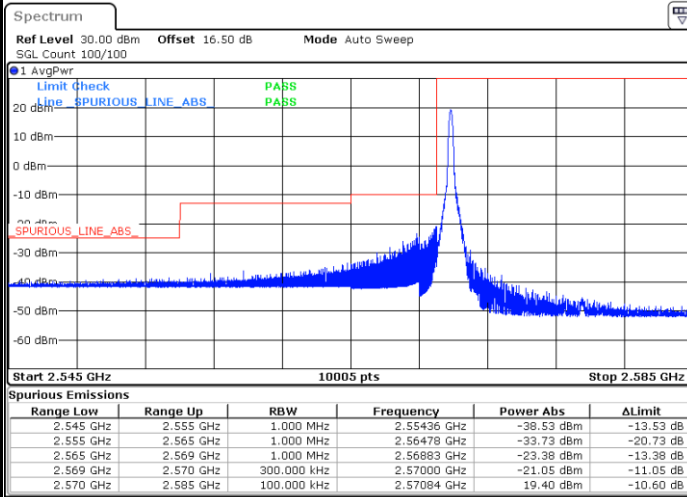

Date: 19.FEB.2022 03:21:10

Highest Band Edge / 1 RB

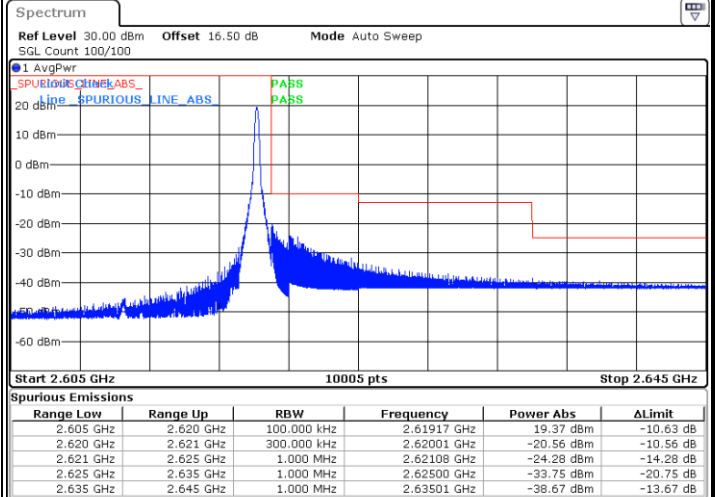

Date: 19.FEB.2022 03:23:54

Lowest Band Edge / Full RB

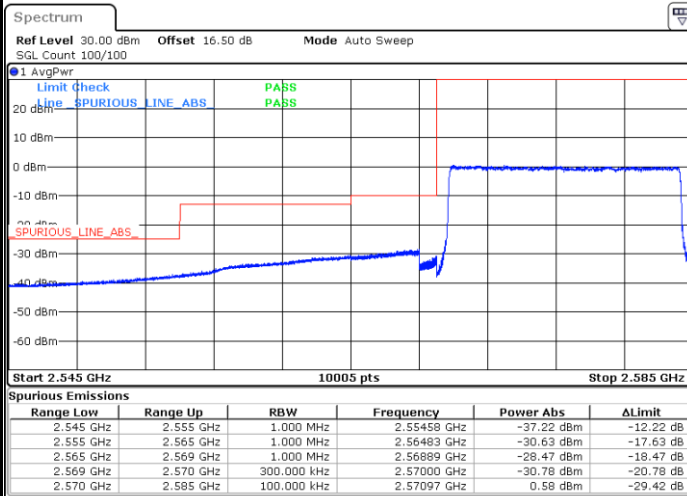

Date: 19.FEB.2022 03:22:04

Highest Band Edge / Full RB

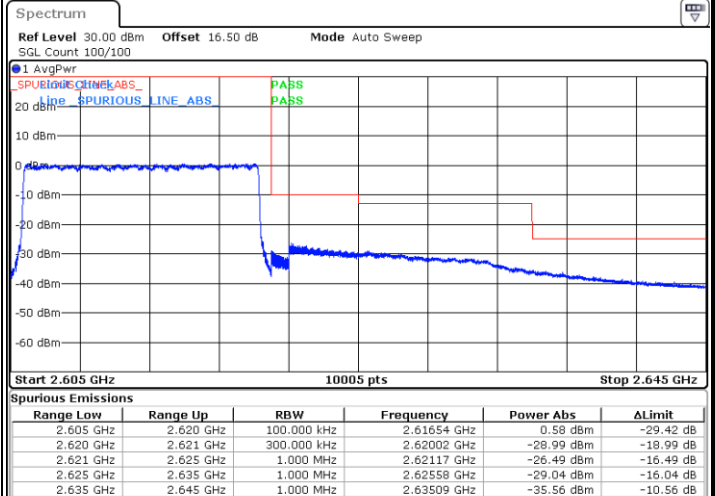

Date: 19.FEB.2022 03:22:59



LTE Band 38 / 20MHz / QPSK

Lowest Band Edge / 1 RB

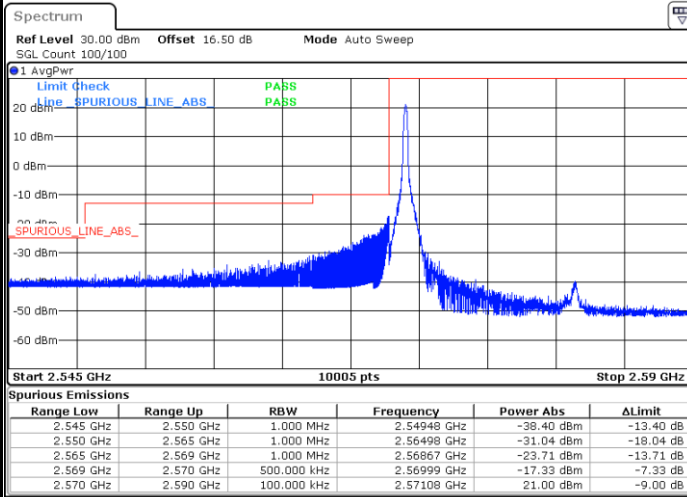

Date: 19.FEB.2022 03:24:50

Highest Band Edge / 1 RB

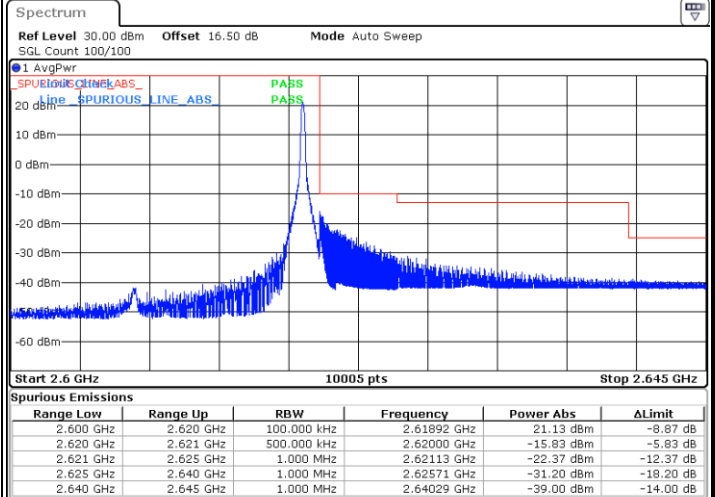

Date: 19.FEB.2022 03:30:19

Lowest Band Edge / Full RB

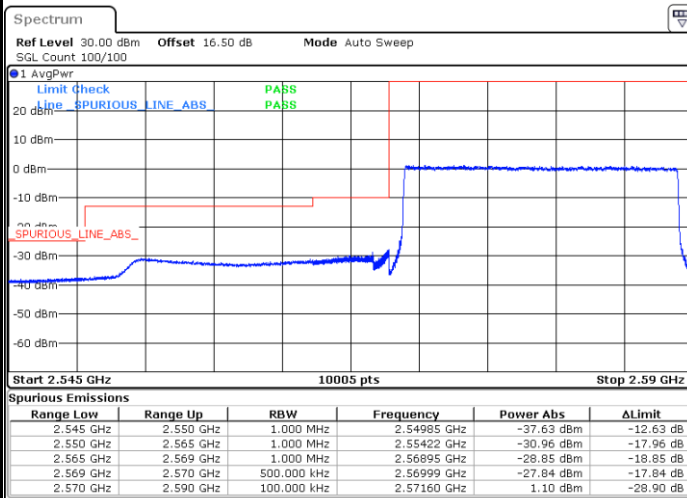

Date: 19.FEB.2022 03:26:39

Highest Band Edge / Full RB

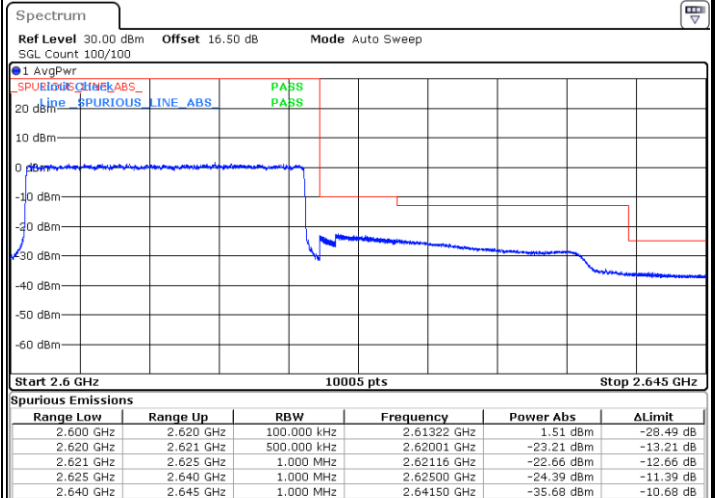

Date: 19.FEB.2022 03:28:28



LTE Band 38 / 20MHz / 16QAM

Lowest Band Edge / 1 RB

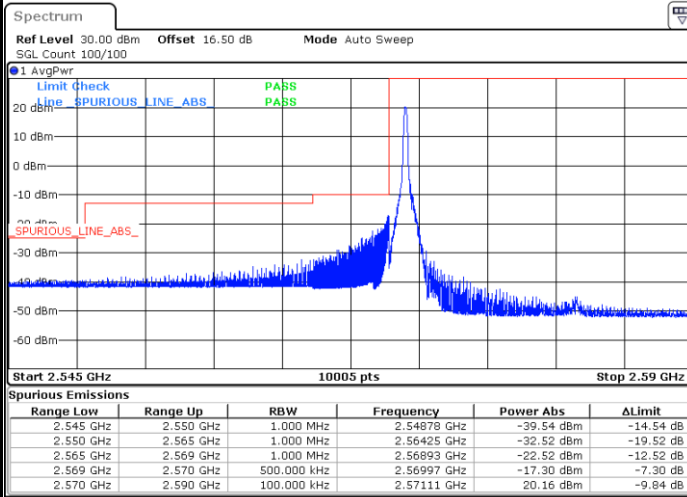

Date: 19.FEB.2022 03:25:44

Highest Band Edge / 1 RB

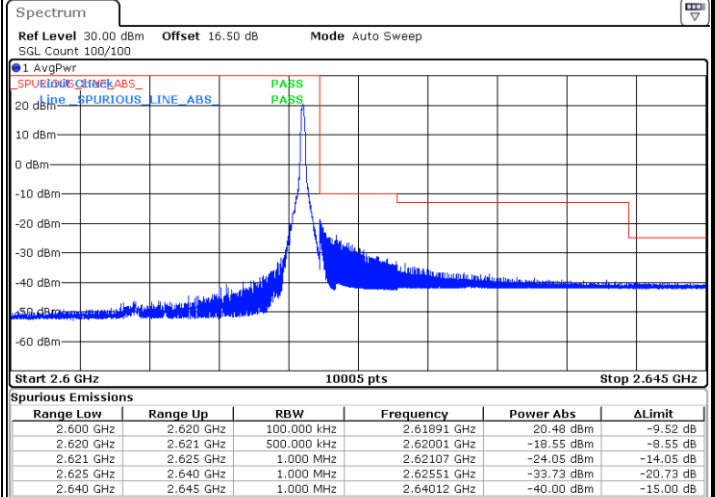

Date: 19.FEB.2022 03:31:14

Lowest Band Edge / Full RB

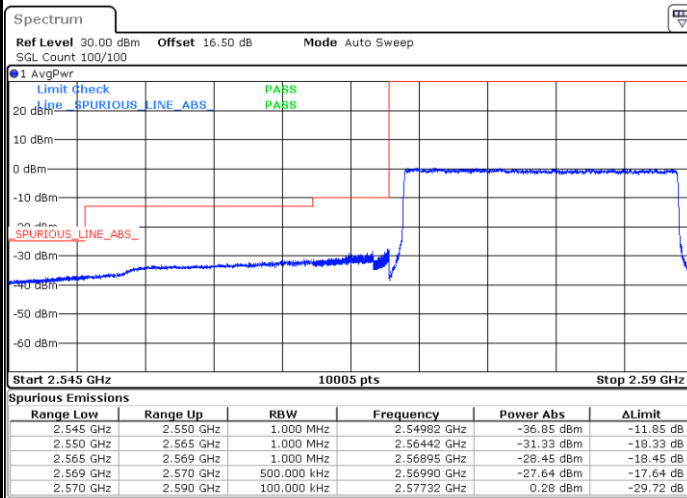

Date: 19.FEB.2022 03:27:33

Highest Band Edge / Full RB

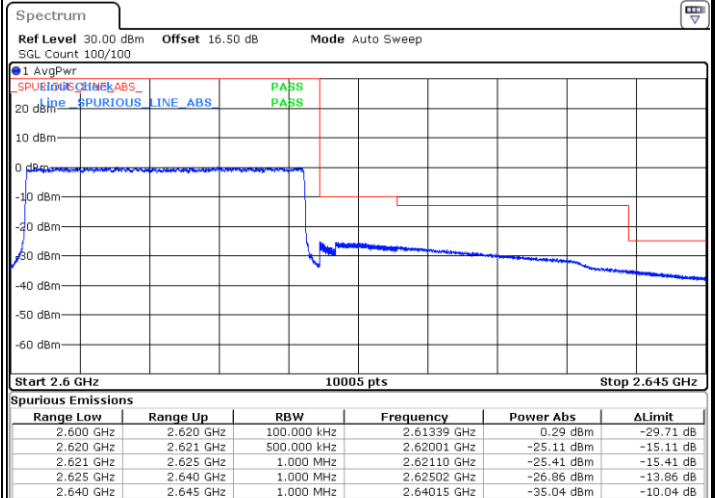

Date: 19.FEB.2022 03:29:24



LTE Band 38 / 20MHz / 64QAM

Lowest Band Edge / 1 RB

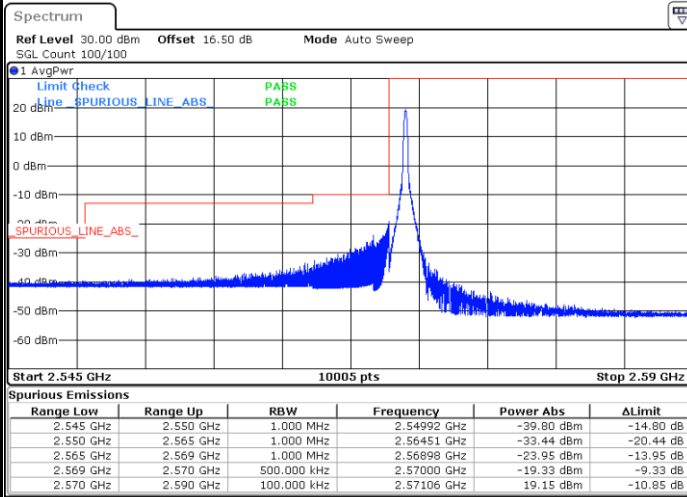

Date: 19.FEB.2022 03:32:09

Highest Band Edge / 1 RB

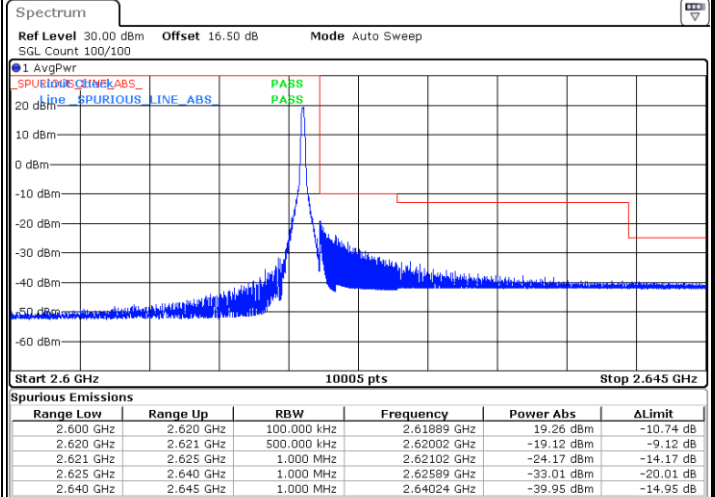

Date: 19.FEB.2022 03:34:55

Lowest Band Edge / Full RB

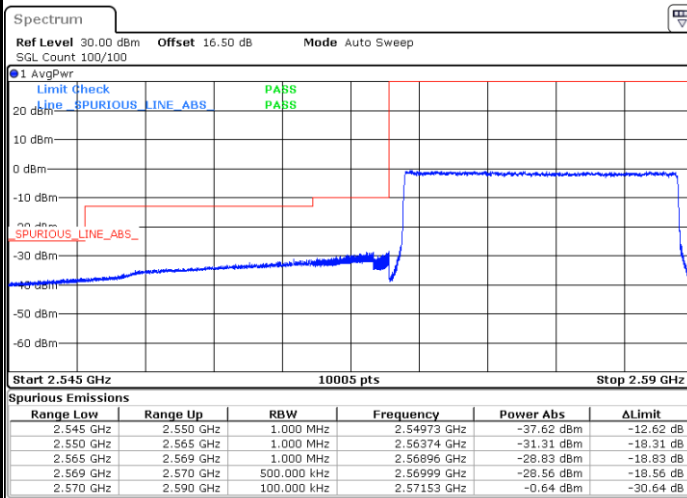

Date: 19.FEB.2022 03:33:04

Highest Band Edge / Full RB

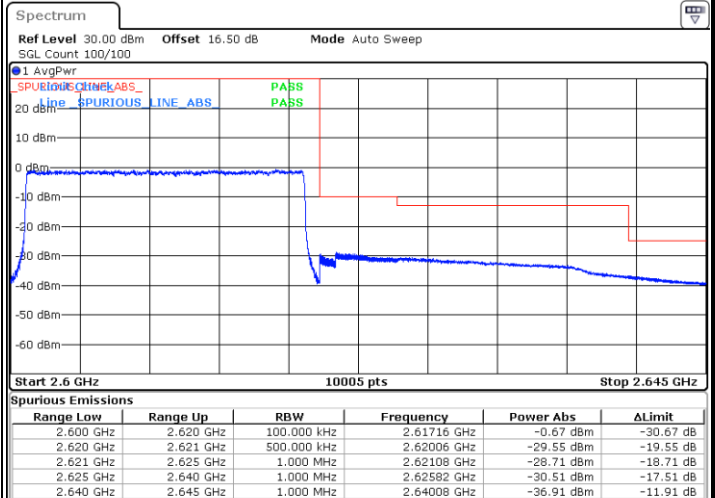

Date: 19.FEB.2022 03:34:00



Conducted Spurious Emission

LTE Band 38 / 5MHz

Lowest Channel / QPSK

Middle Channel / QPSK

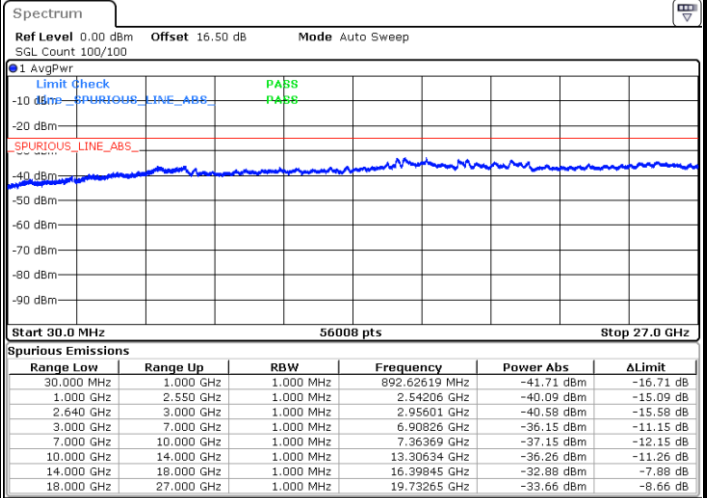
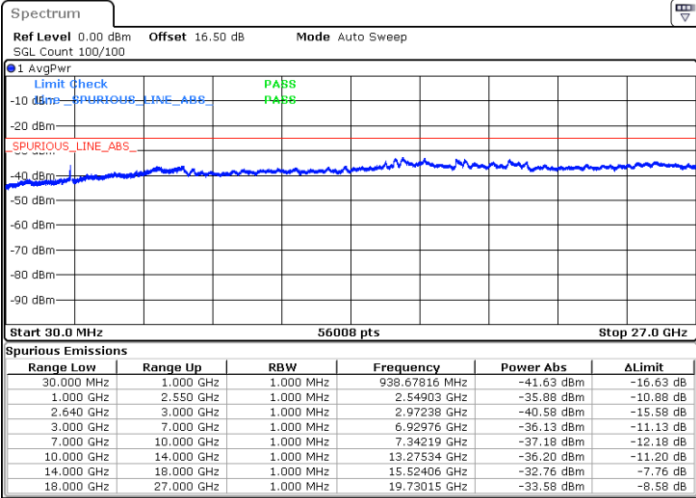

Date: 19.FEB.2022 03:36:00

Date: 19.FEB.2022 03:37:04

Highest Channel / QPSK

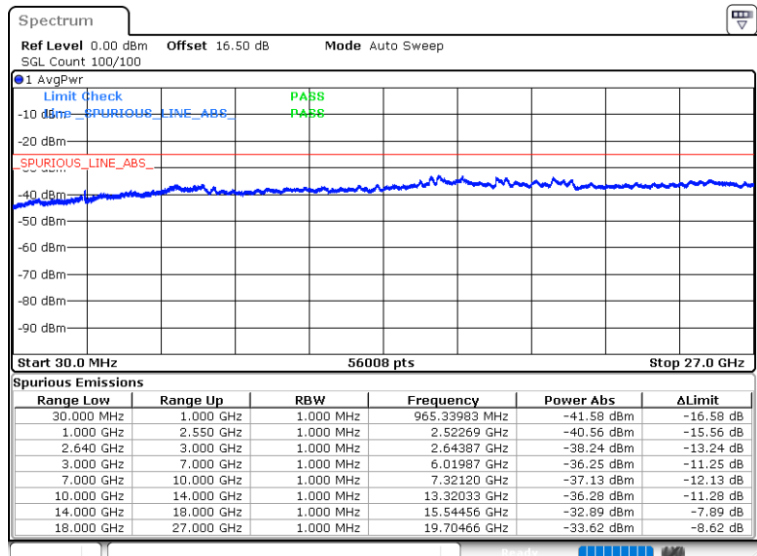

Date: 19.FEB.2022 03:38:07



LTE Band 38 / 10MHz

Lowest Channel / QPSK

Middle Channel / QPSK

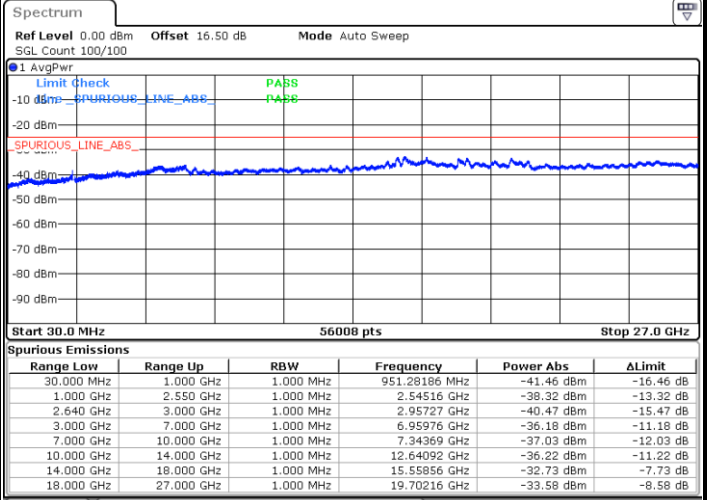
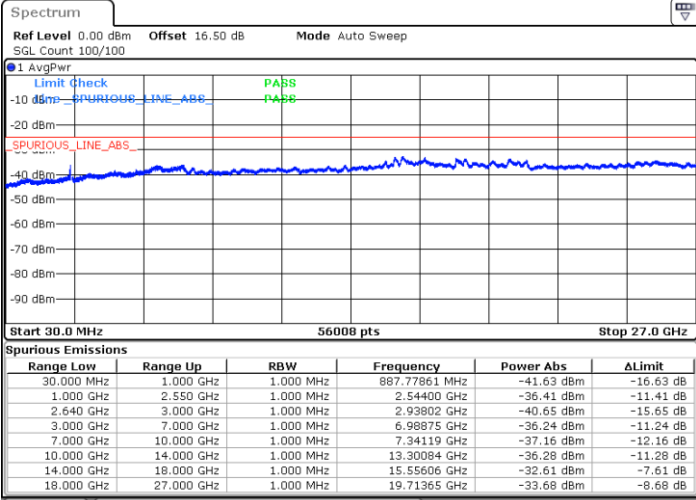

Date: 19.FEB.2022 03:39:12

Date: 19.FEB.2022 03:40:17

Highest Channel / QPSK

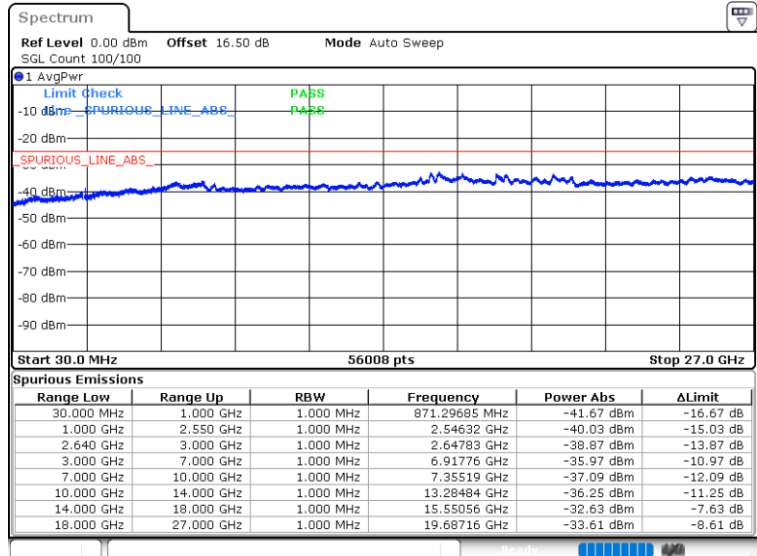

Date: 19.FEB.2022 03:41:20



LTE Band 38 / 15MHz

Lowest Channel / QPSK

Middle Channel / QPSK

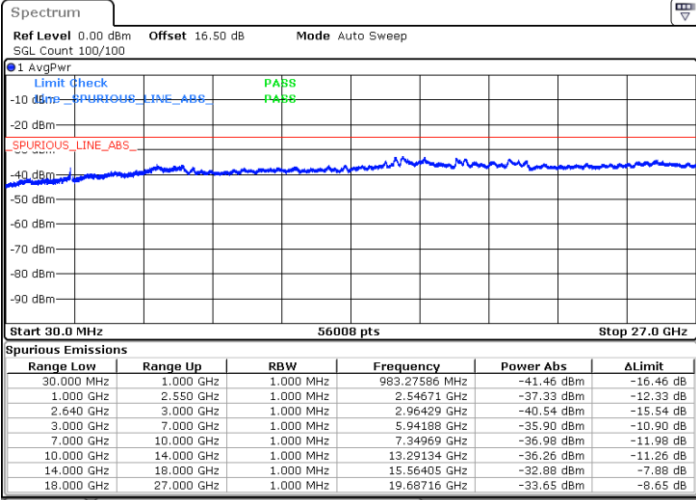

Date: 19.FEB.2022 03:42:26

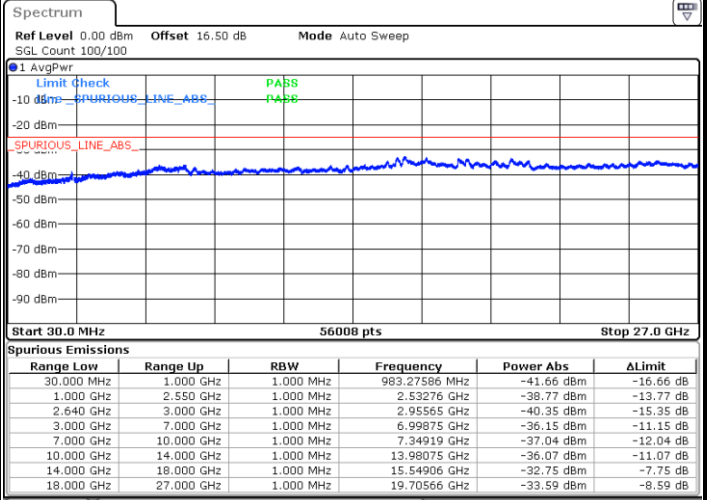

Date: 19.FEB.2022 03:43:30

Highest Channel / QPSK

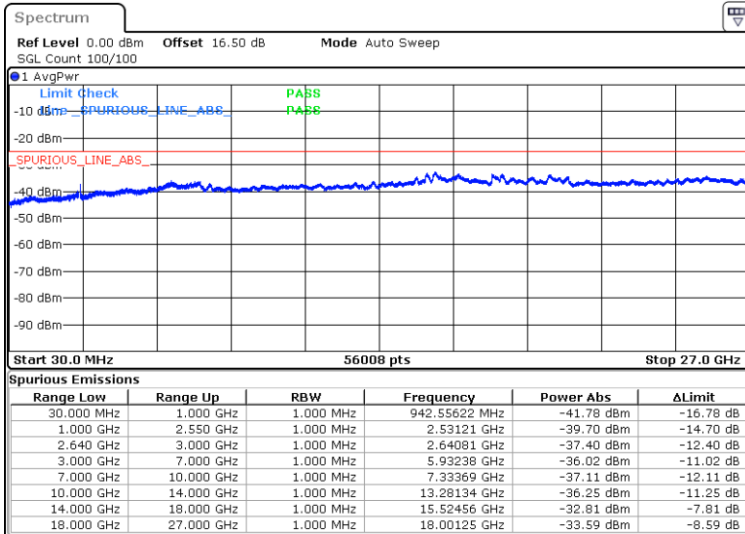

Date: 19.FEB.2022 03:44:33



LTE Band 38 / 20MHz

Lowest Channel / QPSK

Middle Channel / QPSK

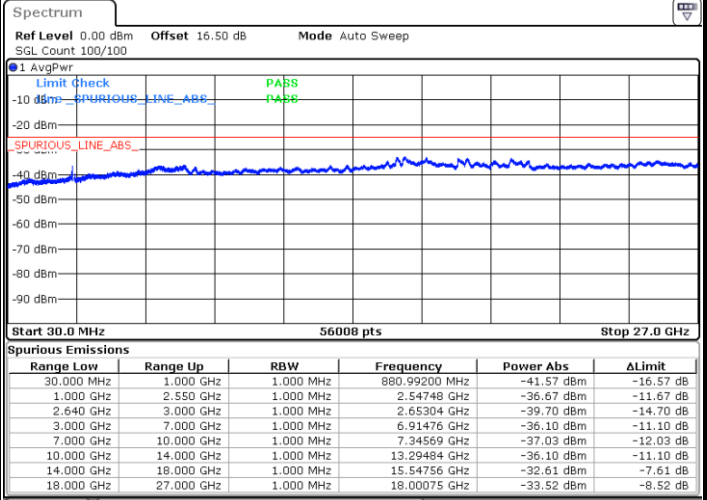
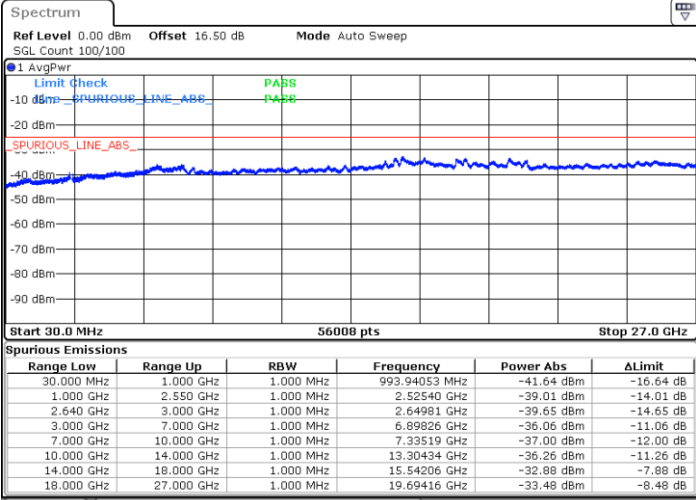

Date: 19.FEB.2022 03:45:38

Date: 19.FEB.2022 03:46:42

Highest Channel / QPSK

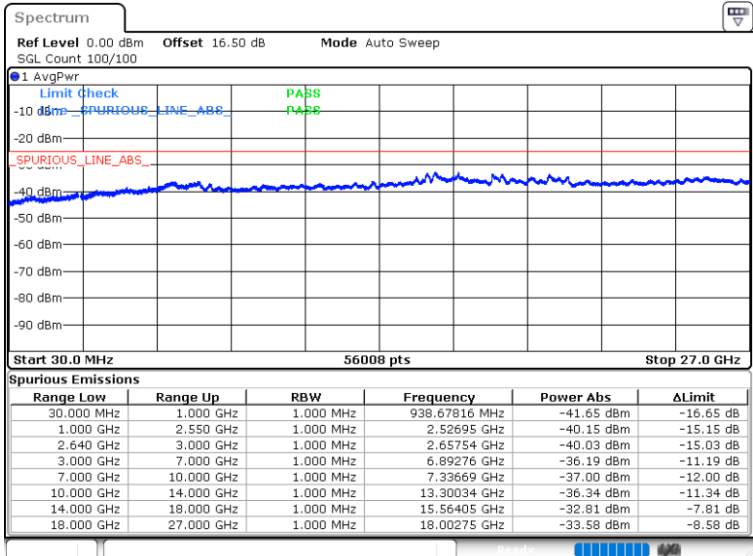

Date: 19.FEB.2022 03:47:45



Frequency Stability

Test Conditions		LTE Band 38 (QPSK) / Middle Channel	Limit
Temperature (°C)	Voltage (Volt)	BW 10MHz	Note 2.
		Deviation (ppm)	Result
50	Normal Voltage	0.0018	PASS
40	Normal Voltage	0.0014	
30	Normal Voltage	0.0023	
20(Ref.)	Normal Voltage	0.0000	
10	Normal Voltage	0.0018	
0	Normal Voltage	0.0009	
-10	Normal Voltage	0.0018	
-20	Normal Voltage	0.0005	
-30	Normal Voltage	0.0020	
20	Maximum Voltage	0.0031	
20	Normal Voltage	0.0018	
20	Battery End Point	0.0005	

Note:

1. Normal Voltage =3.87 V. ; Battery End Point (BEP) =3.4 V. ; Maximum Voltage =4.2 V.
2. The frequency fundamental emissions stay within the authorized frequency block.



Appendix B. Test Results of Radiated Test

<Ant. 0>

LTE Band 5

LTE Band 5 / 10MHz / QPSK									
Channel	Frequency (MHz)	EIRP (dBm)	Limit (dBm)	Over Limit (dB)	SPA Reading (dBm)	S.G. Power (dBm)	TX Cable loss (dB)	TX Antenna Gain (dBi)	Polarization (H/V)
Lowest	1652	-57.45	-13	-44.45	-73.43	-58.33	6.35	9.38	H
	2479	-58.56	-13	-45.56	-75.84	-58.74	8.07	10.40	H
	3306	-56.54	-13	-43.54	-76.48	-57.29	9.18	12.08	H
									H
									H
									H
									H
	1652	-57.36	-13	-44.36	-73.33	-58.24	6.35	9.38	V
	2479	-58.57	-13	-45.57	-75.7	-58.75	8.07	10.40	V
	3306	-56.24	-13	-43.24	-76.27	-56.99	9.18	12.08	V
									V
									V
									V
									V

Remark: Spurious emissions within 30-1000MHz were found more than 20dB below limit line.



LTE Band 12

LTE Band 12 / 10MHz / QPSK									
Channel	Frequency (MHz)	EIRP (dBm)	Limit (dBm)	Over Limit (dB)	SPA Reading (dBm)	S.G. Power (dBm)	TX Cable loss (dB)	TX Antenna Gain (dBi)	Polarization (H/V)
Middle	1408	-59.31	-13	-46.31	-74.05	-58.58	5.85	7.27	H
	2112	-51.61	-13	-38.61	-69.01	-51.73	7.17	9.44	H
	2816	-57.81	-13	-44.81	-76.18	-57.98	8.60	10.92	H
									H
									H
									H
									H
	1408	-59.40	-13	-46.40	-74.49	-58.67	5.85	7.27	V
	2112	-51.77	-13	-38.77	-69.23	-51.89	7.17	9.44	V
	2816	-57.91	-13	-44.91	-76.14	-58.08	8.60	10.92	V
									V
									V
									V
									V

Remark: Spurious emissions within 30-1000MHz were found more than 20dB below limit line.



<Ant. 1>

LTE Band 2

LTE Band 2 / 20MHz / QPSK									
Channel	Frequency (MHz)	EIRP (dBm)	Limit (dBm)	Over Limit (dB)	SPA Reading (dBm)	S.G. Power (dBm)	TX Cable loss (dB)	TX Antenna Gain (dBi)	Polarization (H/V)
Lowest	3702	-54.57	-13	-41.57	-76.34	-56.74	9.93	12.10	H
	5553	-53.19	-13	-40.19	-77.43	-52.67	13.67	13.15	H
	7404	-45.84	-13	-32.84	-76.57	-43.28	13.95	11.39	H
									H
									H
									H
									H
	3702	-54.13	-13	-41.13	-75.78	-56.30	9.93	12.10	V
	5553	-52.45	-13	-39.45	-77.24	-51.93	13.67	13.15	V
	7404	-45.48	-13	-32.48	-76.39	-42.92	13.95	11.39	V
									V
									V
									V
									V

Remark: Spurious emissions within 30-1000MHz were found more than 20dB below limit line.



LTE Band 7

LTE Band 7 / 20MHz / QPSK									
Channel	Frequency (MHz)	EIRP (dBm)	Limit (dBm)	Over Limit (dB)	SPA Reading (dBm)	S.G. Power (dBm)	TX Cable loss (dB)	TX Antenna Gain (dBi)	Polarization (H/V)
Highest	5102	-52.39	-25	-27.39	-76.92	-52.98	12.06	12.65	H
	7653	-46.54	-25	-21.54	-76.16	-43.21	14.96	11.63	H
	10204	-42.67	-25	-17.67	-76.36	-36.48	17.17	10.98	H
									H
									H
									H
									H
	5102	-52.14	-25	-27.14	-76.94	-52.73	12.06	12.65	V
	7653	-46.41	-25	-21.41	-76.1	-43.08	14.96	11.63	V
	10204	-42.64	-25	-17.64	-75.91	-36.45	17.17	10.98	V
									V
									V
									V
									V

Remark: Spurious emissions within 30-1000MHz were found more than 20dB below limit line.



LTE Band 38

LTE Band 38 / 20MHz / QPSK									
Channel	Frequency (MHz)	EIRP (dBm)	Limit (dBm)	Over Limit (dB)	SPA Reading (dBm)	S.G. Power (dBm)	TX Cable loss (dB)	TX Antenna Gain (dBi)	Polarization (H/V)
Lowest	5142	-52.47	-25	-27.47	-77.08	-53.02	12.12	12.67	H
	7713	-46.43	-25	-21.43	-76.03	-43.45	14.64	11.66	H
	10284	-42.99	-25	-17.99	-76.7	-36.76	17.16	10.93	H
									H
									H
									H
									H
	5142	-52.34	-25	-27.34	-77.2	-52.89	12.12	12.67	V
	7713	-46.60	-25	-21.60	-76.26	-43.62	14.64	11.66	V
	10284	-43.01	-25	-18.01	-76.39	-36.78	17.16	10.93	V
									V
									V
									V
									V
Middle	5172	-52.43	-25	-27.43	-77.09	-52.96	12.16	12.69	H
	7758	-46.37	-25	-21.37	-75.95	-43.66	14.39	11.68	H
	10344	-43.12	-25	-18.12	-76.83	-36.85	17.16	10.89	H
									H
									H
									H
									H
	5172	-52.64	-25	-27.64	-77.54	-53.17	12.16	12.69	V
	7758	-46.40	-25	-21.40	-76.04	-43.69	14.39	11.68	V
	10344	-43.13	-25	-18.13	-76.59	-36.86	17.16	10.89	V
									V
									V
									V
									V
								V	



LTE Band 38 / 20MHz / QPSK									
Channel	Frequency (MHz)	EIRP (dBm)	Limit (dBm)	Over Limit (dB)	SPA Reading (dBm)	S.G. Power (dBm)	TX Cable loss (dB)	TX Antenna Gain (dBi)	Polarization (H/V)
Highest	5202	-53.06	-25	-28.06	-77.77	-53.56	12.21	12.71	H
	7803	-46.72	-25	-21.72	-76.29	-44.23	14.18	11.69	H
	10404	-42.52	-25	-17.52	-76.24	-36.22	17.16	10.86	H
									H
									H
									H
									H
	5202	-52.69	-25	-27.69	-77.64	-53.19	12.21	12.71	V
	7803	-46.46	-25	-21.46	-76.09	-43.97	14.18	11.69	V
	10404	-43.15	-25	-18.15	-76.69	-36.85	17.16	10.86	V
									V
									V
									V
									V

Remark: Spurious emissions within 30-1000MHz were found more than 20dB below limit line.