

# TEST REPORT FOR NFC TESTING

---

Report No: SRTC2022-9004(F)-22022405(N)

Product ID: AEF002/AEF003

Applicant: Sharp Corporation

Manufacturer: Sharp Corporation

Specification: CFR 47, Part 15, Sections 15.225, 15.207, 15.215(2021)

FCC ID: APYHRO00307

The State Radio\_monitoring\_center Testing Center (SRTC)

15th Building, No.30, Shixing Street, Shijingshan District, Beijing, P.R.China

Tel: 86-10-57996183 Fax: 86-10-57996388

## CONTENTS

|   |    |
|---|----|
| <b>1. GENERAL INFORMATION</b> .....               | 2  |
| 1.1 Notes of the test report .....                | 2  |
| 1.2 Information about the testing laboratory..... | 2  |
| 1.3 Applicant's details .....                     | 2  |
| 1.4 Manufacturer's details.....                   | 2  |
| 1.5 Test environment .....                        | 3  |
| <b>2. DETAILS OF EQUIPMENT UNDER TEST</b> .....   | 3  |
| 2.1 Final equipment builds status .....           | 3  |
| 2.2 Support equipment.....                        | 3  |
| <b>3. REFERENCE SPECIFICATION</b> .....           | 4  |
| <b>4. KEY TO NOTES AND RESULT CODES</b> .....     | 4  |
| <b>5. RESULT SUMMARY</b> .....                    | 5  |
| <b>6. TEST RESULTS</b> .....                      | 6  |
| 6.1 Occupied Bandwidth .....                      | 6  |
| 6.2 In-band emission.....                         | 8  |
| 6.3 Radiated emission 9 kHz to 30 MHz .....       | 10 |
| 6.4 Radiated emission 30 MHz to 1 GHz .....       | 12 |
| 6.5 Carrier frequency stability .....             | 14 |
| <b>7. MEASUREMENT UNCERTAINTIES</b> .....         | 15 |
| <b>8. TEST EQUIPMENT</b> .....                    | 15 |
| <b>ANNEX A – Test Result</b> .....                | 16 |

## **1. GENERAL INFORMATION**

### **1.1 Notes of the test report**

The test report may only be reproduced or published in full. Reproduction or publication of extracts from the report requires the prior written permission of The State Radio\_monitoring\_center Testing Center (SRTC). The test results relate only to individual items of the samples which have been tested. The certification and accreditation identifiers used in this report shall not be applicable to the tested or calibrated samples thereof. The manufacturer shall not mark the tested samples or items (or a separate part of the item) with the identifiers of certification and accreditation to mislead relevant parties about the tested samples or items.

### **1.2 Information about the testing laboratory**

|                      |  |
|----------------------|--|
| Company:             | The State Radio_monitoring_center Testing Center (SRTC)              |
| Address:             | 15th Building, No.30 Shixing Street, Shijingshan District, P.R.China |
| City:                | Beijing  |
| Country or Region:   | P.R.China  |
| Contacted person:    | Liu Jia  |
| Tel:                 | +86 10 57996183  |
| Fax:                 | +86 10 57996388  |
| Email:               | liujiaf@srtc.org.cn  |
| Registration number: | 239125   |

### **1.3 Applicant's details**

|          |   |
|----------|---|
| Company: | Sharp Corporation   |
| Address: | 1 Takumi-cho, Sakai-ku, Sakai City, Osaka 590-8522, Japan |

### **1.4 Manufacturer's details**

|          |   |
|----------|---|
| Company: | Sharp Corporation   |
| Address: | 1 Takumi-cho, Sakai-ku, Sakai City, Osaka 590-8522, Japan |

## 1.5 Test environment

|   |            |
|---|------------|
| Date of Receipt of test sample at SRTC: | 2022-02-14 |
| Testing Start Date:                     | 2022-02-16 |
| Testing End Date:                       | 2022-03-11 |

| Environmental Data: | Temperature (°C) | Humidity (%) |
|---------------------|------------------|--------------|
| Ambient:            | 25               | 40           |

|  |     |
|--|-----|
| Normal Supply Voltage (V d.c.):          | 4.0 |
| Maximum Extreme Supply Voltage (V d.c.): | 4.0 |
| Minimum Extreme Supply Voltage (V d.c.): | 3.7 |

## 2. DETAILS OF EQUIPMENT UNDER TEST

### 2.1 Final equipment builds status

|                     |   |
|---------------------|---|
| Operating Frequency | 13.56 MHz                                       |
| Antenna Type        | Loop Antenna                                    |
| Modulation Type     | ASK   |
| Power Supply        | Battery or Charger                              |
| Software Revision:  | A1280   |
| Hardware Revision:  | PVT(Remodeled to the equivalent of MP products) |
| IMEI:               | 004401230772846<br>004401230782845              |

### 2.2 Support equipment

The following support equipment was used to exercise the EUT during testing:

N/A

### **3. REFERENCE SPECIFICATION**



| Specification          | Version | Title  |
|------------------------|---------|--|
| 2.202(a)               | 2021    | Occupied bandwidth   |
| 15.225(a)-(c)          | 2021    | In-band emission   |
| 15.225(d)              | 2021    | Radiated emission 9 kHz to 30 MHz  |
| 15.205(b)<br>15.225(d) | 2021    | Radiated emission 30 MHz to 1 GHz  |
| 15.225(e)              | 2021    | Carrier frequency stability  |
| ANSI C63.10            | 2013    | Standard of Procedures for Compliance Testing of Unlicensed Wireless Devices |

### **4. KEY TO NOTES AND RESULT CODES**

| Code | Meaning  |
|------|--|
| PASS | Test result shows that the requirements of the relevant specification have been met.     |
| FAIL | Test result shows that the requirements of the relevant specification have not been met. |
| N/A  | Test case is not applicable.   |
| N/T  | Test case is not tested.   |

## 5. RESULT SUMMARY

| NO. | Item                              | Results |
|-----|-----------------------------------|---------|
| 1   | Occupied bandwidth                | Pass    |
| 2   | Conducted emission test           | N/T     |
| 3   | In-band emission                  | Pass    |
| 4   | Radiated emission 9 kHz to 30 MHz | Pass    |
| 5   | Radiated emission 30 MHz to 1 GHz | Pass    |
| 6   | Carrier frequency stability       | Pass    |

|  |   |
|--|---|
| This Test Report Is Issued by:<br>Mr. Peng Zhen<br> | Checked by:<br>Ms. Liu Jia<br> |
| Tested by:<br>Mr. Li Bin<br>                        | Issued date:<br><br>20220316  |

## **6. TEST RESULTS**

### **6.1 Occupied Bandwidth**

#### **6.1.1 Test conditions and test configuration**

The occupied bandwidth according to CFR 47 Part 2, section 2.202(a), is measured as the 99% emission bandwidth, i.e. below its lower and above its upper frequency limits, the mean powers radiated are each equal to 0.5% of the total mean power radiated by a given emission.

The occupied bandwidth according to ANSI C63.10, section 6.9.1; is measured as the frequency range defined by the points that are 20 dB down relative to the maximum level of the modulated carrier.

The span range of the spectrum analyzer display shall be between two times and five times of the occupied bandwidth. The resolution bandwidth of the spectrum analyzer should be approximately 1% to 5% of the occupied bandwidth, unless otherwise specified, depending on the applicable requirement.

The video bandwidth shall be at least three times greater than the resolution bandwidth. The dynamic range of the spectrum analyzer at the selected resolution bandwidth shall be more than 10 dB below the target “dB down” (attenuation) requirement.

If antenna is detachable bandwidth measurements shall be performed at the antenna connector (conducted measurement) when the transmitter is adjusted in accordance with the tune-up procedure, if applicable. The RF output terminals are connected to a spectrum analyzer. If required, a resistive matching network equal to the impedance specified or employed for the antenna is used as well as dc block and appropriate attenuators (50 Ohms). The electrical characteristics of the radio frequency load attached to the output terminals shall be stated, if applicable. If radiated measurements are performed the same test setups and instruments are used as with radiated emission measurements for the appropriate frequency range.

The analyzer settings are specified by the test description of the appropriate test record(s).

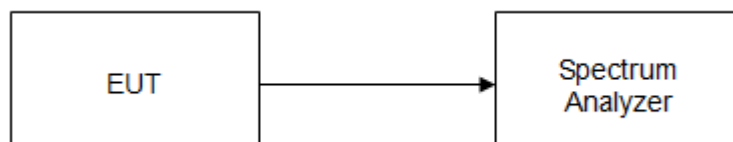

### 6.1.2 Test limit

The 20 dB bandwidth shall be specified in operating frequency band.

### 6.1.3 Test data

| 20 dBc Point(Low) | 20 dBc Point(High) | Operating Frequency Band(MHz) | Pass/Fail |
|-------------------|--------------------|-------------------------------|-----------|
| 13.5587MHz        | 13.5613mHz         | 13.553-13.567                 | Pass      |

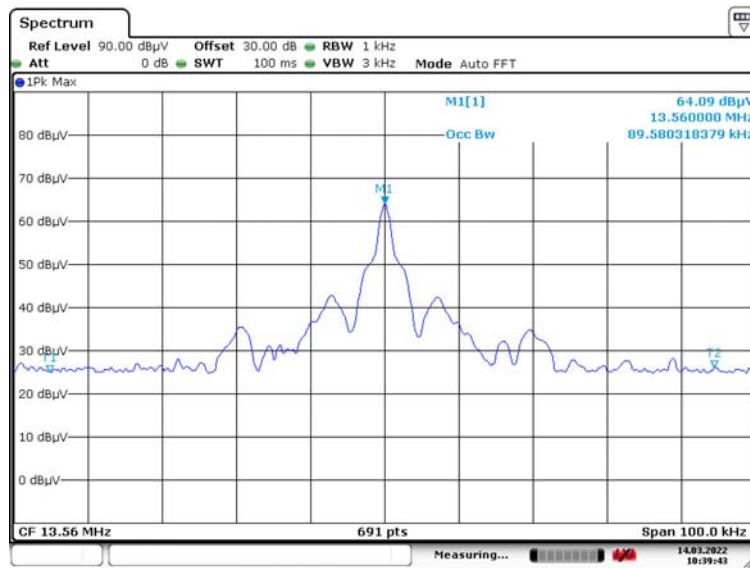

Date: 14.MAR.2022 10:39:43



## 6.2 In-band emission

### 6.2.1 Test conditions and test configuration

In the case of a transmitter with an integral or dedicated antenna, the radiated H-field is defined in the direction of maximum field strength under specified conditions of measurement.

The measurements shall be made on an open field test site as specified in standard. Any measured values shall be at least 6 dB above the ambient noise level.

The H-field produced by the equipment shall be measured at standard distance of 3 m. Where this is not practical, e.g. due to physical size of the equipment including the antenna or with use of special field cancelling antenna, then other distances may be used. When another distance is used, the distance used and the field strength value measured shall be stated in the test report. In this case, the measured value at actual test distance shall be extrapolated to 3 m and stated in the test report.

The H-field is measured with a shielded loop antenna connected to a measurement receiver. The measuring bandwidth and detector type of the measurement receiver shall be in accordance with standard.

The equipment under test shall be operated with modulation as defined in standard.

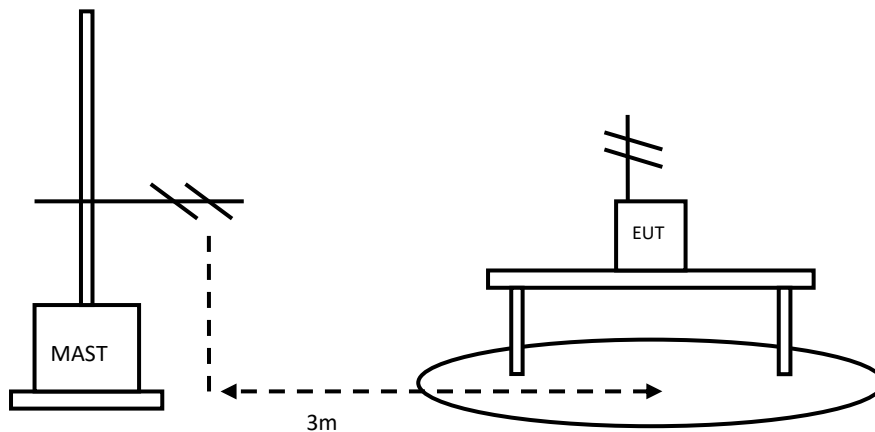

### **6.2.2 Test limit**

- (a) The field strength of any emissions within the band 13.553-13.567 MHz shall not exceed 15,848 microvolts/meter at 30 meters.
- (b) Within the bands 13.410-13.553 MHz and 13.567-13.73 MHz, the field strength of any emissions shall not exceed 334 microvolts/meter at 30 meters.
- (c) Within the bands 13.110-13.43 MHz and 13.710-14.03 MHz the field strength of any emissions shall not exceed 106 microvolts/meter at 30 meters.

### **6.2.3 Test data**

The test results are shown in Appendix A .

## 6.3 Radiated emission 9 kHz to 30 MHz

### 6.3.1 Test conditions and test configuration

The measurements shall be made on an open field test site as specified in standard. Any measured values shall be at least 6 dB above the ambient noise level.

The H-field produced by the equipment shall be measured at standard distance of 3 m. Where this is not practical, e.g. due to physical size of the equipment including the antenna or with use of special field cancelling antenna, then other distances may be used. When another distance is used, the distance used and the field strength value measured shall be stated in the test report. In this case, the measured value at actual test distance shall be extrapolated to 3 m and stated in the test report.

The H-field is measured with a shielded loop antenna connected to a measurement receiver. The measuring bandwidth and detector type of the measurement receiver shall be in accordance with standard.

The equipment under test shall be operated with modulation as defined in standard.

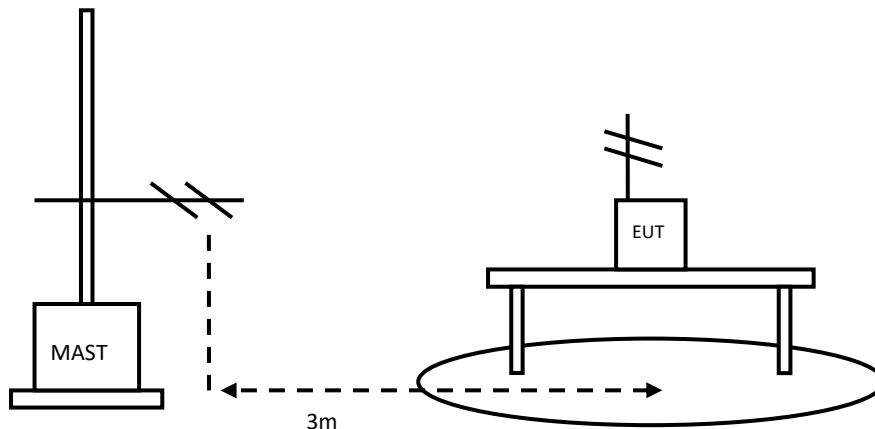

### 6.3.2 Test limit

(a) Except as provided elsewhere in this subpart, the emissions from an intentional radiator shall not exceed the field strength levels specified in the following table:

| Frequency (MHz) | Field strength (microvolts/meter) | Measurement distance (meters) |
|-----------------|-----------------------------------|-------------------------------|
| 0.009-0.490     | 2400/F(kHz)                       | 300                           |
| 0.490-1.705     | 24000/F(kHz)                      | 30                            |
| 1.705-30.0      | 30                                | 30                            |
| 30-88           | 100**                             | 3                             |
| 88-216          | 150**                             | 3                             |
| 216-960         | 200**                             | 3                             |
| Above 960       | 500                               | 3                             |

\*\*Except as provided in paragraph (g), fundamental emissions from intentional radiators operating under this section shall not be located in the frequency bands 54-72 MHz, 76-88 MHz, 174-216 MHz or 470-806 MHz. However, operation within these frequency bands is permitted under other sections of this part, e.g., §§15.231 and 15.241.

### 6.3.3 Test data

The test results are shown in Appendix A .

## 6.4 Radiated emission 30 MHz to 1 GHz

### 6.4.1 Test conditions and test configuration

The measurements shall be made on an open field test site as specified in standard. Any measured values shall be at least 6 dB above the ambient noise level.

The H-field produced by the equipment shall be measured at standard distance of 3 m. Where this is not practical, e.g. due to physical size of the equipment including the antenna or with use of special field cancelling antenna, then other distances may be used. When another distance is used, the distance used and the field strength value measured shall be stated in the test report. In this case, the measured value at actual test distance shall be extrapolated to 3 m and stated in the test report.

The H-field is measured with a shielded loop antenna connected to a measurement receiver. The measuring bandwidth and detector type of the measurement receiver shall be in accordance with standard.

The equipment under test shall be operated with modulation as defined in standard.

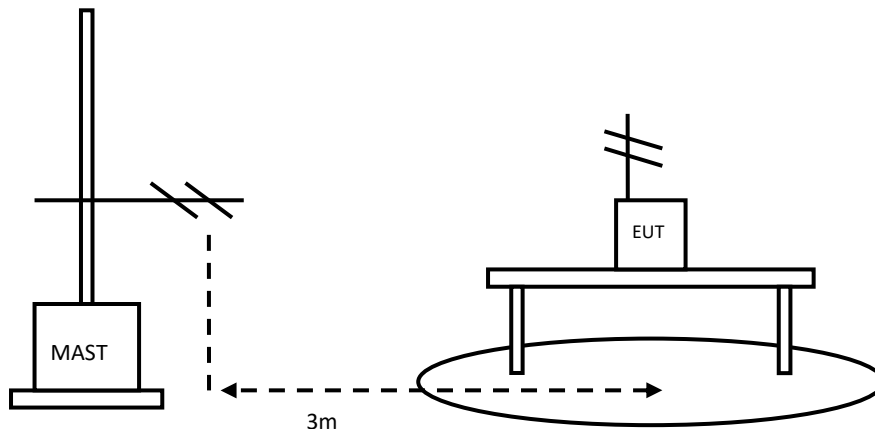

### 6.4.2 Test limit

(a) Except as provided elsewhere in this subpart, the emissions from an intentional radiator shall not exceed the field strength levels specified in the following table:

| Frequency (MHz) | Field strength (microvolts/meter) | Measurement distance (meters) |
|-----------------|-----------------------------------|-------------------------------|
| 0.009-0.490     | 2400/F(kHz)                       | 300                           |
| 0.490-1.705     | 24000/F(kHz)                      | 30                            |
| 1.705-30.0      | 30                                | 30                            |
| 30-88           | 100**                             | 3                             |
| 88-216          | 150**                             | 3                             |
| 216-960         | 200**                             | 3                             |
| Above 960       | 500                               | 3                             |

\*\*Except as provided in paragraph (g), fundamental emissions from intentional radiators operating under this section shall not be located in the frequency bands 54-72 MHz, 76-88 MHz, 174-216 MHz or 470-806 MHz. However, operation within these frequency bands is permitted under other sections of this part, e.g., §§15.231 and 15.241.

### 6.4.3 Test data

The test results are shown in Appendix A .

## 6.5 Carrier frequency stability

### 6.5.1 Test conditions and test configuration

(e) The frequency tolerance of the carrier signal shall be maintained within  $\pm 0.01\%$  of the operating frequency over a temperature variation of  $-20$  degrees to  $+ 50$  degrees C at normal supply voltage, and for a variation in the primary supply voltage from 85% to 115% of the rated supply voltage at a temperature of 20 degrees C. For battery operated equipment, the equipment tests shall be performed using a new battery.

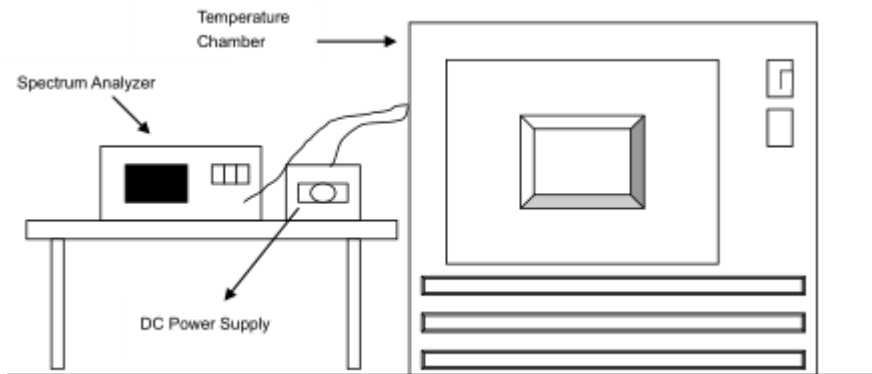

### 6.5.2 Test limit

$\pm 0.01\%$

### 6.5.3 Test data

| Voltage(V) | Temperature( $^{\circ}$ C) | Frequency (MHz) | Measured Frequency (MHz) | Frequency Stability (ppm) |
|------------|----------------------------|-----------------|--------------------------|---------------------------|
| 4.0        | 50                         | 13.56           | 13.560004                | 0.29                      |
| 4.0        | 40                         | 13.56           | 13.560002                | 0.15                      |
| 4.0        | 30                         | 13.56           | 13.560003                | 0.22                      |
| 4.0        | 20                         | 13.56           | 13.560001                | 0.07                      |
| 4.0        | 10                         | 13.56           | 13.560005                | 0.37                      |
| 4.0        | 0                          | 13.56           | 13.560006                | 0.44                      |
| 4.0        | -10                        | 13.56           | 13.560003                | 0.22                      |
| 4.0        | -20                        | 13.56           | 13.560004                | 0.29                      |
| 4.0        | -30                        | 13.56           | 13.560002                | 0.15                      |
| 3.7        | 20                         | 13.56           | 13.560005                | 0.37                      |

## 7. MEASUREMENT UNCERTAINTIES

| Item                                      | Uncertainty        |
|---|--------------------|
| Occupied Bandwidth                        | 0.30 kHz           |
| Carrier frequency stability               | $1 \times 10^{-8}$ |
| Radiated Emission Measurements 9kHz~30MHz | 4.88 dB            |
| Radiated Emission Measurements 30MHz~1GHz | 4.86 dB            |

Uncertainty figures are valid to a confidence level of 95%, k=2

## 8. TEST EQUIPMENT

| Name/ Model                                   | Manufacturer    | S/N              | Cal date   | Cal Due date |
|---|-----------------|------------------|------------|--------------|
| Spectrum Analyzer / FSV                       | ROHDE & SCHWARZ | 101065           | 2021.06.21 | 2022.06.20   |
| Fully-Anechoic Chamber / 12.65m×8.03m×7.50m   | FRANKONIA       | ----             | ----       | ----         |
| Semi-Anechoic/Chamber / 23.18m×16.88m×9.60m   | FRANKONIA       | ---              | ----       | ----         |
| Turn table Diameter:1m                        | FRANKONIA       | ----             | ----       | ----         |
| Turn table Diameter:5m                        | FRANKONIA       | ----             | ----       | ----         |
| Antenna master FAC(MA4.0)                     | MATURO          | ----             | ----       | ----         |
| Antenna master SAC(MA4.0)                     | MATURO          | ----             | ----       | ----         |
| Shielding room / 9.080m×5.255m×3.525m         | FRANKONIA       | ----             | ----       | ----         |
| Double-Ridged Waveguide Horn Antenna / HF 907 | R&S             | 100512           | 2021.06.21 | 2022.06.20   |
| Double-Ridged Waveguide Horn Antenna / HF 907 | R&S             | 100513           | 2021.06.21 | 2022.06.20   |
| Ultra log antenna / HL562                     | R&S             | 100016           | 2021.06.21 | 2022.06.20   |
| Receive antenna /3160-09                      | SCHWARZ-BECK    | 002058-002       | 2021.06.21 | 2022.06.20   |
| EMI test receiver                             | R&S             | 101574           | 2021.06.21 | 2022.06.20   |
| ESR3 EMI test receiver                        | R&S             | 102361           | 2021.04.12 | 2022.04.11   |
| Receive antenna / HL562                       | R&S             | 100167           | 2021.06.21 | 2022.06.20   |
| ENV216 AMN                                    | R&S             | 101881           | 2021.06.21 | 2022.06.20   |
| WLAN AP WIA3300-20                            | SKSpruce        | 8152017060700339 | ---        | ---          |
| Notebook E470c                                | Lenovo          | PF10UZW7         | ---        | ---          |
| Horn antenna / SAS-574                        | A.H.SYSTEMS     | 2581             | 2021.04.22 | 2023.04.21   |
| Loop antenna / HFH2-Z2                        | R&S             | 100340           | 2021.08.21 | 2022.08.20   |
| VULB 9163 Ultra log test antenna              | SCHWARZ-BECK    | 867              | 2021.05.29 | 2023.05.28   |



## ANNEX A – Test Result

### Radiated Emission Measurement

Within the bands

Loop antenna at 3M

(a) The field strength of any emissions within the band 13.553-13.567 MHz shall not exceed 15,848 microvolts/meter at 30 meters.

(b) Within the bands 13.410-13.553 MHz and 13.567-13.710 MHz, the field strength of any emissions shall not exceed 334 microvolts/meter at 30 meters.

(c) Within the bands 13.110-13.410 MHz and 13.710-14.010 MHz the field strength of any emissions shall not exceed 106 microvolts/meter at 30 meters.

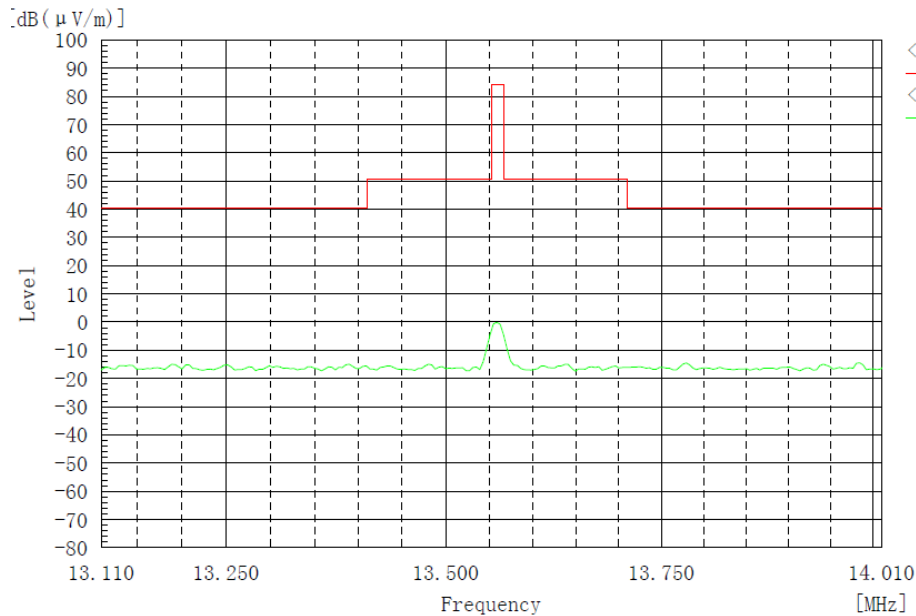

Radiated emission 9 kHz to 30 MHz and 6.4 Radiated emission 30 MHz to 1 GHz

| Frequency (MHz) | Result (dBuV/m) | ARpl (dB) | Pmea (dBuV/m) | Polarity | Limit (dBuV/m) |
|-----------------|-----------------|-----------|---------------|----------|----------------|
| 30.740          | 0.7             | -24.0     | 24.7          | Vertical | 40.00          |
| 38.425          | 3.1             | -22.7     | 25.8          | Vertical | 40.00          |
| 42.205          | 5.8             | -21.7     | 27.5          | Vertical | 40.00          |
| 52.028          | 6.5             | -21.7     | 27.7          | Vertical | 40.00          |
| 64.400          | 14.7            | -23.3     | 38.0          | Vertical | 40.00          |
| 84.522          | 19.8            | -26.6     | 46.4          | Vertical | 40.00          |

Note: The above test results are the worst case.

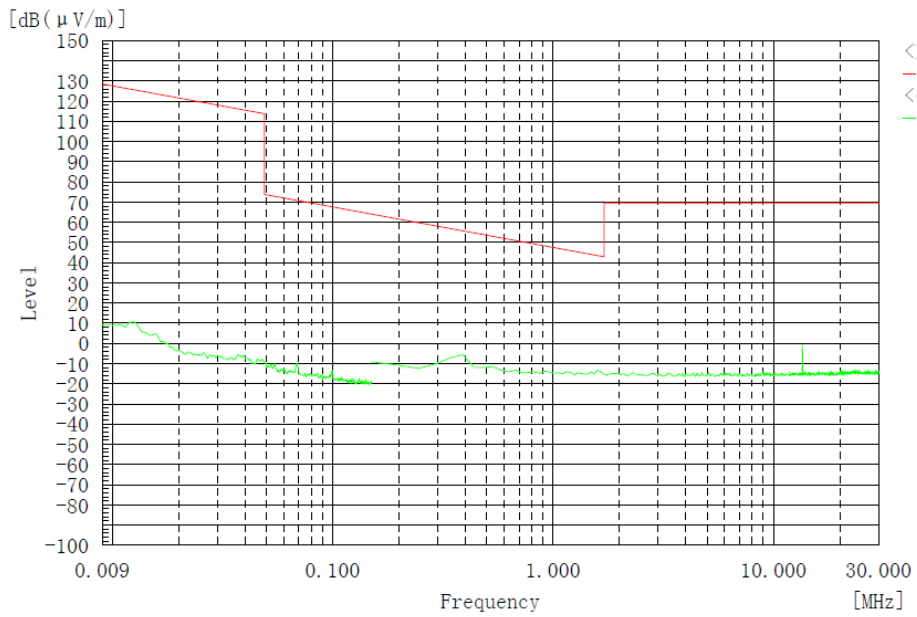

Frequency Range: 9kHz-30 MHz

Detector: QP mode

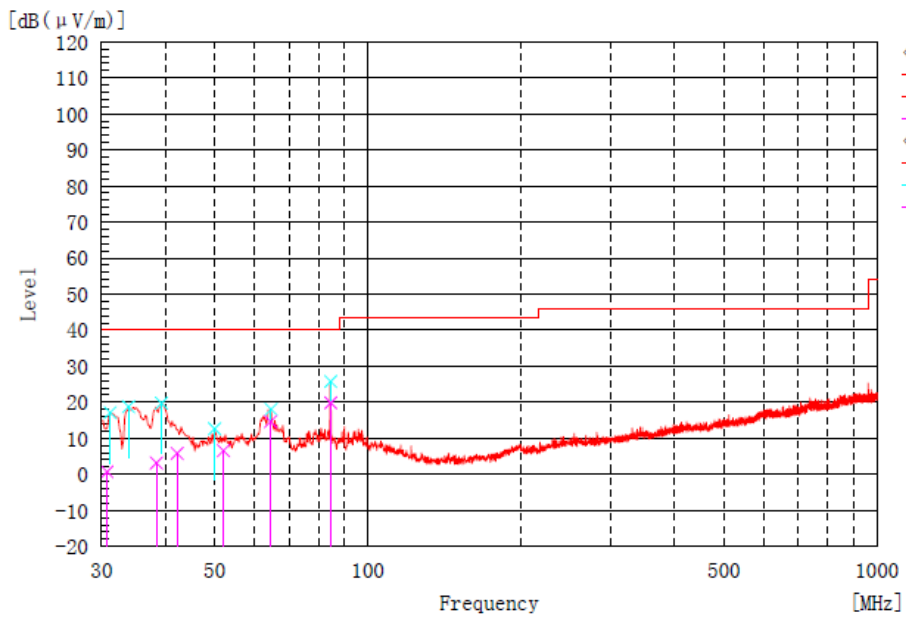

Frequency Range: 30MHz-1000 MHz

Detector: QP mode

---End of Test Report---