

TEST REPORT

Report No.: SRTC2020-9003(F)-0088
Product Name: Smart phone
Applicant: Sharp Corporation
Manufacturer: Sharp Corporation
Specification: FCC Part15B (Certification)
(2020 edition)
ANSI C63.4-2014
FCC ID: APYHRO00294

The State Radio_monitoring_center Testing Center (SRTC)
15th Building, No.30 Shixing Street, Shijingshan District,
Beijing, China

Tel: 86-10-57996183 Fax: 86-10-57996388

CONTENTS

1. General information	3
1.1 Notes of the test report.....	3
1.2 Information about the testing laboratory	3
1.3 Applicant's details.....	3
1.4 Manufacturer's details	3
1.5 Application details.....	4
1.6 Reference specification	4
1.7 Information of EUT	4
1.7.1 General information	4
1.7.2 EUT details.....	5
1.7.3 Auxiliary equipment details	5
2. Test information	6
2.1 Summary of the test results	6
2.2 Test result	7
2.2.1 Conducted Emissions-FCC Part15.107.....	7
2.2.2 Radiated Emissions-FCC Part15.109.....	13
2.3. List of test equipments	20

1. General information

1.1 Notes of the test report

The test report may only be reproduced or published in full. Reproduction or publication of extracts from the report requires the prior written permission of The State Radio_monitoring_center Testing Center (SRTC).

The test results relate only to individual items of the samples which have been tested.

1.2 Information about the testing laboratory

Company: The State Radio_monitoring_center Testing Center (SRTC)
Address: 15th Building, No.30 Shixing Street, Shijingshan District
Testing location: No.80, Zhaojiachang, BeizangCun, Daxing District, Beijing, China.
City: Beijing
Country or Region: China
Contacted person: Liu Jia
Tel: +86 10 57996183
Fax: +86 10 57996388
Email: liujiaf@srtc.org.cn

1.3 Applicant's details

Company: Sharp Corporation
Address: 1 Takumi-cho, Sakai-ku, Sakai City,Osaka 590-8522,Japan
City: Osaka
Country or Region: Japan
Contacted person: Mr.Masaaki Nishikawa
Tel: ---
Email: ---

1.4 Manufacturer's details

Company: Sharp Corporation
Address: 1 Takumi-cho, Sakai-ku, Sakai City,Osaka 590-8522,Japan
City: Osaka
Country or Region: Japan
Contacted person: Mr.Masaaki Nishikawa
Tel: ---
Email: ---

1.5 Application details

Date of reception of test sample: 26th Feb. 2021

Date of test: 26th Feb. 2021 to 19th Mar. 2021

1.6 Reference specification

FCC Part 15B, 2020 (Certification)

1.7 Information of EUT

1.7.1 General information

Product Name of EUT	Smart phone
FCC ID	APYHRO00294
Frequency Range	GSM: GSM850 / DCS1900 WCDMA: FDD II/ FDD IV / FDD V LTE: FDD 2/ FDD 4/ FDD 5/FDD 7/ FDD 12/ FDD 13/ FDD 17/TDD 38/ TDD 41 Bluetooth: 2.4~2.4835GHz WiFi: 2.4~2.4835GHz 5.15-5.35GHz/5.475-5.725GHz 5.725GHz-5.85GHz
Power Supply	Charger/Battery
Nominal Voltage	3.85V
Extreme Temperature	Lowest: -10°C Highest: +55°C
Extreme Voltage	Minimum: 3.7V Maximum: 4V
HW Version	DVT(Remodeled to the equivalent of MP products)
SW Version	01.00.00

1.7.2 EUT details

No.	Product Name	IMEI
EUT1	Smart phone	004401230191500/004401230191443

1.7.3 Auxiliary equipment details

AE (Auxiliary Equipment) 1#: Charger

Manufacturer	DVE
Model Number	DSA-10PF06-05 FUS
Input Voltage	100V-240V AC
Output Voltage	5V DC

AE (Auxiliary Equipment) 2#: Battery

Manufacturer	Tohoku murata manufacturing
Model Number	UBATIA306AFN1

AE (Auxiliary Equipment) 3#: USB cable

Manufacturer	Kingpower
Model Number	K201-05130-00

AE (Auxiliary Equipment) 4#: Headset

Manufacturer	DONGGUAN AMBAI
Model Number	AB-HI02SJ

AE (Auxiliary Equipment) 5#: Headset



Manufacturer	Panasonic
Model Number	RP-HJS150-K

Note1: This application has two Kinds of Headset. In this report, the result exercised by the EUT1 , charger AE1, the Battery AE2 , the USB cable AE3 and the Headset AE4.

2. Test information

2.1 Summary of the test results

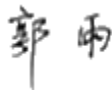
No.	Test case	FCC reference	Verdict
1	Conducted emissions	15.107	Pass
2	Radiated emissions	15.109	Pass

Approved By: Liu Wei Director of the test department 	Checked By: Guo Yu Vice director of the test department 
Tested by: Mr. Lv Youyou Test engineer 	Issued date: 2021.04.12

2.2 Test result

2.2.1 Conducted Emissions-FCC Part15.107

Ambient condition:

Temperature	Relative humidity	Pressure
21.3°C	40.6%	100.5kPa

Test Setup with charger:

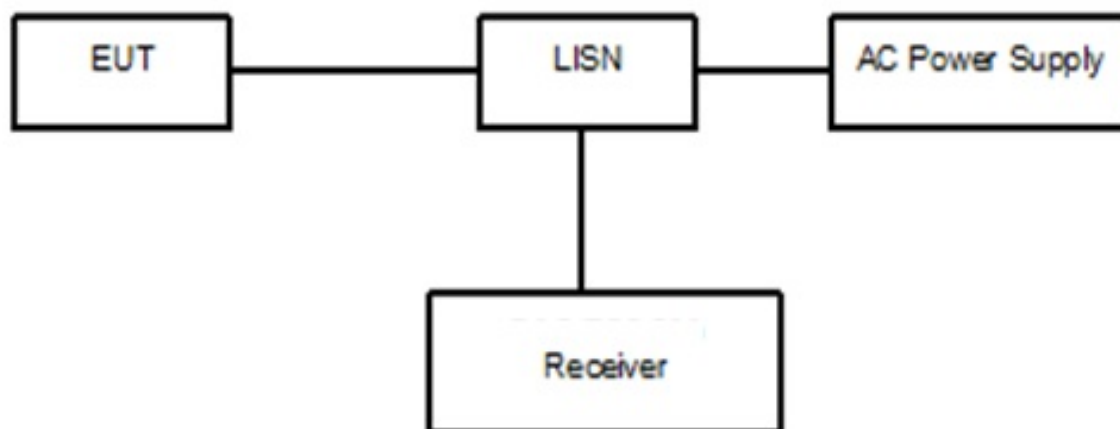

Figure 1

Test Procedure:

The EUT is placed on a non-metallic table 0.8m above the horizontal metal reference ground plane. The EUT is connected with LISN via the charger. The LISN is connected to the reference ground.

The test set-up and the test methods are performed according to ANSI C63.4:2014.

Then start the test software EMC32. Sweep the whole frequency band through the range from 150 KHz to 30 MHz with RBW 9kHz, VBW 30kHz. The measurement should be done for both L line and N line. During pre-test, the receiver uses both peak detector and average detector. And the final test, the receiver uses both average detector and Quasi-peak detector.

The data of cable loss has been calibrated in full testing frequency range before the testing.

Test Setup with laptop:

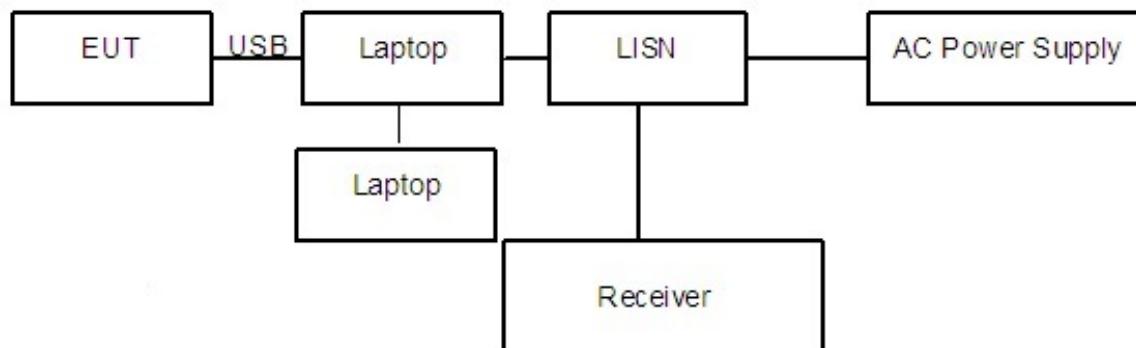

Figure 2

Test Procedure:

The EUT is placed on a non-metallic table 0.8m above the horizontal metal reference ground plane. The accessories of the EUT are connected with the EUT such as headset etc. The EUT was connected with a laptop via the USB cable and was charged. The laptop's LAN port is connected with another laptop via cable. And the data transferring between two laptops is maintained.

The AC main power supply of the laptop is connected to LISN and LISN is connected to the reference ground. The test set-up and the test methods are performed according to ANSI C63.4:2014.

Then start the test software EMC32. Sweep the whole frequency band through the range from 150 KHz to 30 MHz. The measurement should be done for both L line and N line. During pre-test, the receiver uses both peak detector and average detector. And the final test, the receiver uses both average detector and Quasi-peak detector.

The data of cable loss has been calibrated in full testing frequency range before the testing.

A “reference path loss” Corr.(dB) is established and the $L_{cable}+ATT+VDF$ is the attenuation of “reference path loss”, and including the cable loss, the attenuation of the attenuator, the voltage division factor of AMN.

The measurement results are obtained as described below:

$$P_{result}=P_{mea}+Corr.(dB)$$

Sample calculation: $(26.63dB\mu V) = (-3.07 dB\mu V) + (29.7 dB)$, the corresponding frequency is 0.167057MHz.

Limit:

Frequency of Emission(MHz)	Limits(dB μ V)	
	Quasi-peak	Average
0.15~0.5	66 to 56*	56 to 46*
0.5~5	56	46
5~30	60	50

Note: * Decreases with the logarithm of the frequency

Test result:

Noise Level of the Measuring Instrument

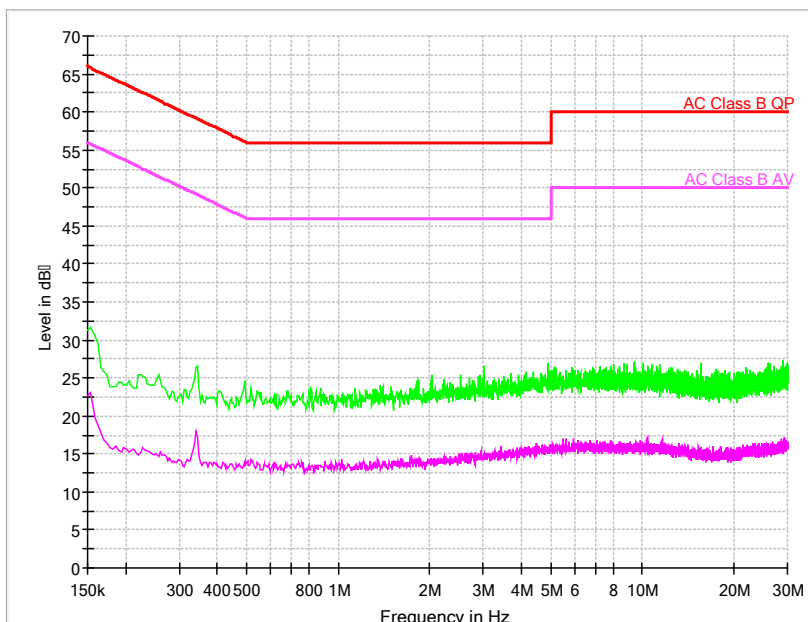

Pic1. Conducted emission L and N Line

EUT1+charger:

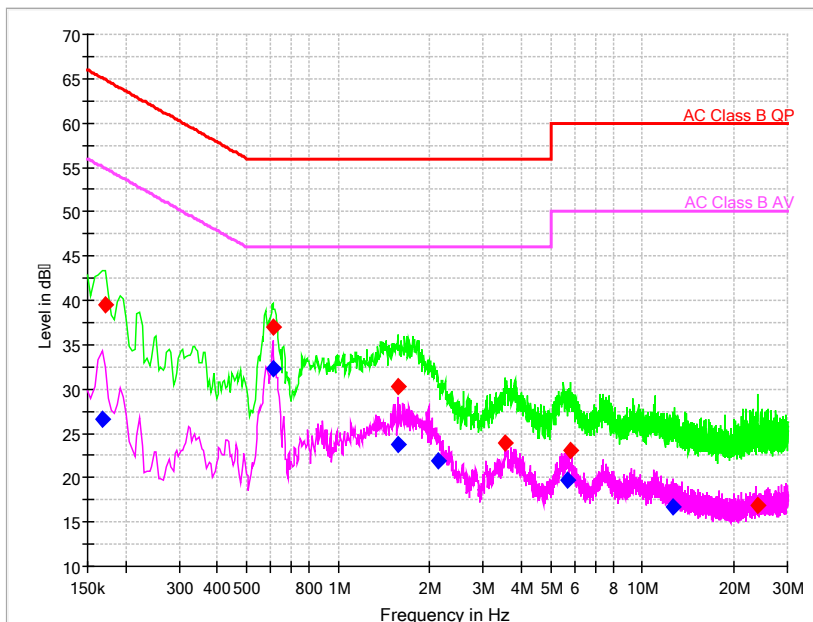

Pic2. Conducted emission L&N Line Voltage: 120VAC

Frequency (MHz)	QuasiPeak (dBμV)	Average (dBμV)	Limit (dBμV)	Margin (dB)	Line	Corr. (dB)	P _{mea} QuasiPeak (dBμV)	P _{mea} Average (dBμV)
0.167057	---	26.63	55.11	28.48	L1	29.7	---	-3.07
0.171321	39.43	---	64.90	25.47	L1	29.7	9.73	---
0.610543	---	32.28	46.00	13.72	L1	29.7	---	2.58
0.610543	37.02	---	56.00	18.98	L1	29.7	7.32	---
1.570007	30.30	---	56.00	25.70	L1	29.8	0.5	---
1.570007	---	23.73	46.00	22.27	L1	29.8	---	-6.07
2.124364	---	21.87	46.00	24.13	L1	29.8	---	-7.93
3.531579	23.87	---	56.00	32.13	L1	29.8	-5.93	---
5.706364	---	19.75	50.00	30.25	L1	29.8	---	-10.05
5.804443	23.15	---	60.00	36.85	L1	29.8	-6.65	---
12.652886	---	16.77	50.00	33.23	L1	30.0	---	-13.23
23.829579	16.91	---	60.00	43.09	N	30.5	-13.59	---

EUT1+charger:

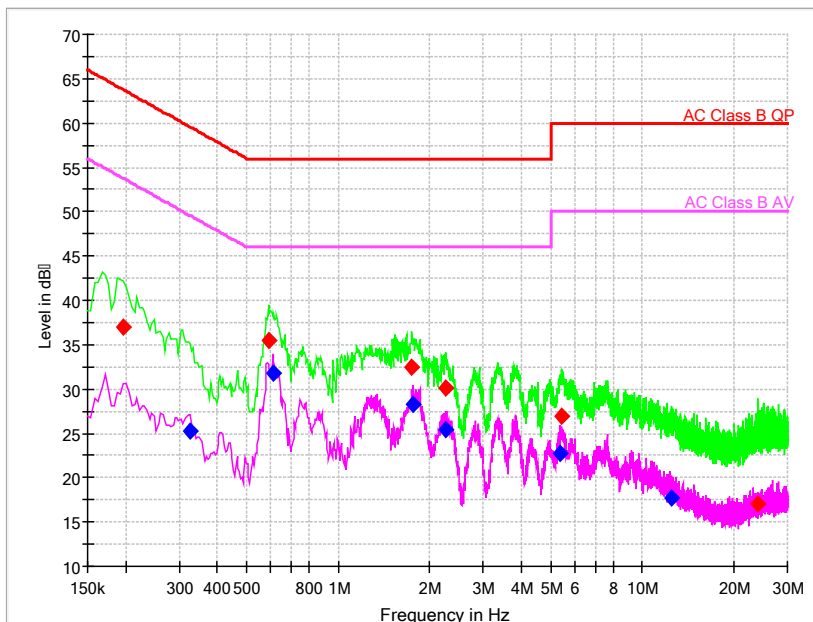

Pic3. Conducted emission L&N Line Voltage: 240VAC

Frequency (MHz)	QuasiPeak (dBμV)	Average (dBμV)	Limit (dBμV)	Margin (dB)	Line	Corr. (dB)	P _{mea} QuasiPeak (dBμV)	P _{mea} Average (dBμV)
0.196907	36.91	---	63.74	26.83	L1	29.7	7.21	---
0.324836	---	25.32	49.58	24.26	L1	29.7	---	-4.38
0.589221	35.52	---	56.00	20.48	L1	29.7	5.82	---
0.610543	---	31.79	46.00	14.21	L1	29.7	---	2.09
1.749107	32.49	---	56.00	23.51	N	29.8	2.69	---
1.770429	---	28.19	46.00	17.81	L1	29.8	---	-1.61
2.256557	---	25.50	46.00	20.50	L1	29.8	---	-4.3
2.265086	30.12	---	56.00	25.88	N	29.8	0.32	---
5.390807	---	22.76	50.00	27.24	L1	29.8	---	-7.04
5.429186	26.94	---	60.00	33.06	L1	29.8	-2.86	---
12.414086	---	17.71	50.00	32.29	L1	30.0	---	-12.29
23.957507	16.99	---	60.00	43.01	L1	30.5	-13.51	---

EUT1+Laptop:

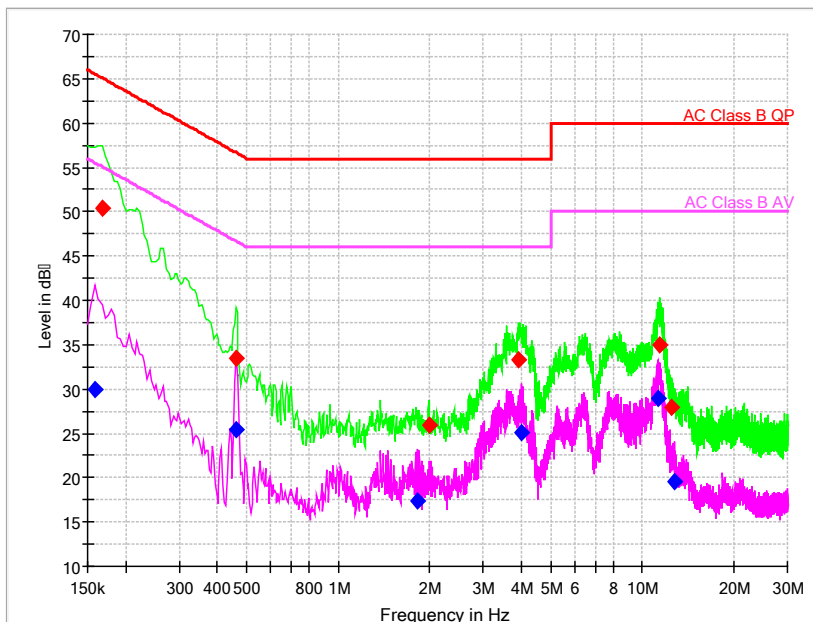

Pic4. Conducted emission L&N Line

Frequency (MHz)	QuasiPeak (dB μ V)	Average (dB μ V)	Limit (dB μ V)	Margin (dB)	Line	Corr. (dB)	P _{mea} QuasiPeak (dB μ V)	P _{mea} Average (dB μ V)
0.158529	---	29.94	55.54	25.60	L1	29.7	---	-0.85
0.167057	50.38	---	65.11	14.73	L1	29.7	17.31	---
0.461293	---	25.46	46.67	21.21	N	29.7	---	-0.9
0.461293	33.52	---	56.67	23.15	L1	29.7	10.71	---
1.821600	---	17.45	46.00	28.55	L1	29.8	---	-5.68
1.983643	25.84	---	56.00	30.16	N	29.8	2.83	---
3.906836	33.27	---	56.00	22.73	L1	29.8	0.08	---
3.987857	---	25.11	46.00	20.89	L1	29.8	---	-8.2
11.279786	---	28.94	50.00	21.06	L1	29.9	-1.8	---
11.463150	34.93	---	60.00	25.07	L1	29.9	---	-9.39
12.54201	27.88	---	60.00	32.12	L1	30.0	---	-10.94
12.77228	---	19.63	50.00	30.37	L1	30.0	-7.96	---

2.2.2 Radiated Emissions-FCC Part15.109

Ambient condition:

Temperature	Relative humidity	Pressure
22.8°C	41.1%	100.8kPa

Test Setup:

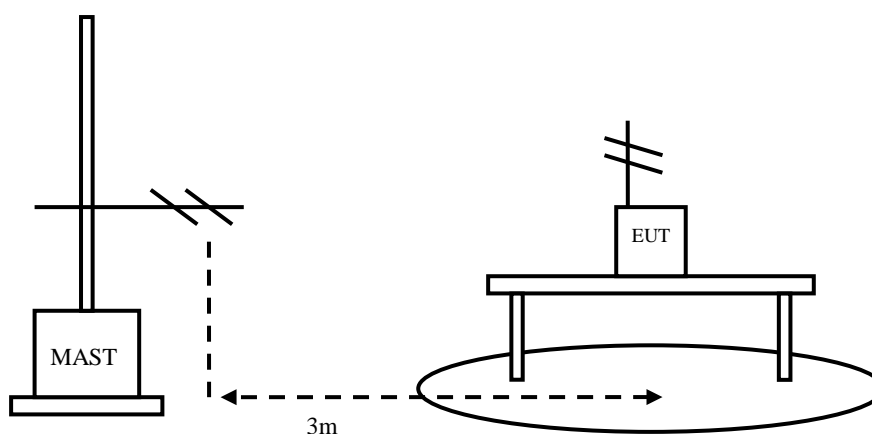

Figure 3

Test Procedure:

EUT+Charger:

The EUT should be placed on a non-metallic table 80cm above the ground plane. The receive antennas shall be moved from 1 to 4 meters. The distance between EUT and receive antenna should be 3 meters.

The EUT should work in idle mode. The accessories of the EUT are connected with the EUT such as headset etc. Open the following functions of EUT: Camera, flash lamp, GPS and video. The test set-up and the test methods are performed according to ANSI C63.4:2014.

Then start the test software EMC32. Sweep the whole frequency band through the range from 30MHz to 1GHz, using receive log period antenna VULB 9163.

During the test, the height of receive antenna shall be moved from 1 to 4 meters, and the antenna shall be performed under horizontal and vertical polarization. The turn table shall be rotated from 0 to 360 degrees for detecting the maximum of radiated spurious signal level. The measurements shall be repeated with orthogonal polarization of the test antenna. The EUT is laid in two modes as follow: 1. put the EUT in horizontal direction; 2. put the EUT in vertical direction.

The data of cable loss and antenna factor have been calibrated in full testing frequency range before the testing. All test results are performed with max hold at the horizontal and vertical polarity.

RBW=120kHz, VBW=300kHz, when the test frequency: $30\text{MHz} < f < 1\text{GHz}$

RBW=1MHz, VBW=3MHz, when the test frequency: $f > 1\text{GHz}$

EUT+Laptop:

The EUT should be placed on a non-metallic table 80cm above the ground plane. The receive antennas shall be moved from 1 to 4 meters. The distance between EUT and receive antenna should be 3 meters.

The accessories of the EUT are connected with the EUT such as headset etc. The EUT was connected with a laptop via the USB cable and transferred the data by copying large files from laptop to the EUT. The test set-up and the test methods are performed according to ANSI C63.4:2014

Then start the test software EMC32. Sweep the whole frequency band through the range from 30MHz to 1GHz, using receive log period antenna VULB 9163.

During the test, the height of receive antenna shall be moved from 1 to 4 meters, and the antenna shall be performed under horizontal and vertical polarization. The turn table shall be rotated from 0 to 360 degrees for detecting the maximum of radiated spurious signal level. The measurements shall be repeated with orthogonal polarization of the test antenna. The EUT is laid in two modes as follow: 1. put the EUT in horizontal direction; 2. put the EUT in vertical direction.

The data of cable loss and antenna factor have been calibrated in full testing frequency range before the testing.

A “reference path loss” is established and the A_{Rpl} is the attenuation of “reference path loss”, and including the gain of receive antenna, the gain of the preamplifier, the cable loss.

The measurement results are obtained as described below:

$$\text{Result} = P_{\text{mea}} + A_{Rpl}$$

Sample calculation: $(21.31 \text{ dB}\mu\text{V/m}) = (42.81 \text{ dB}\mu\text{V}) + (-21.5 \text{ dB/m})$, the corresponding frequency is 30.040000MHz.

Limit:

Frequency of Emission(MHz)	Limits	
	Detector	Unit (dB μ V/m)
30~88	Quasi-peak	40
88~216	Quasi-peak	43.5
216~960	Quasi-peak	46
960~1000	Quasi-peak	54
1000~5th harmonic of the highest frequency or 40GHz, whichever is lower	Average	54
	Peak	74

Test result:

EUT1+charger:

Frequency(MHz)	Result(dBuV/m)	A _{Rpl} (dB/m)	P _{mea} (dBuV)	Polarity
30.040000	21.31	-21.5	42.81	V
85.852000	23.29	-22.5	45.79	V
173.278000	16.11	-21.2	37.31	V
195.924000	23.63	-19.4	43.03	V
380.552500	15.35	-13.5	28.85	V
895.037000	15.61	-3.3	18.91	V

EUT1+Laptop:

Frequency(MHz)	Result(dBuV/m)	A _{Rpl} (dB/m)	P _{mea} (dBuV)	Polarity
41.232000	15.39	-18.4	33.79	V
66.734500	19.91	-21.1	41.01	V
168.002500	16.78	-21.5	38.28	V
216.017500	24.75	-18.8	43.55	V
360.014000	30.01	-14.2	44.21	V
996.568000	20.98	-2.1	23.08	V

EUT1+charger: refer to Pic5 to Pic8

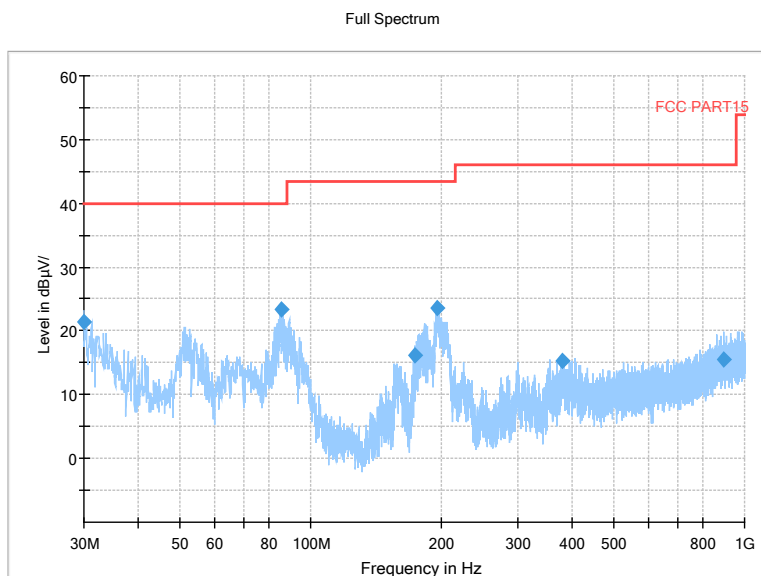

Pic5. Radiated emission (30MHz – 1GHz)

Note: The test data in the graph includes two polarizations: horizontal and vertical

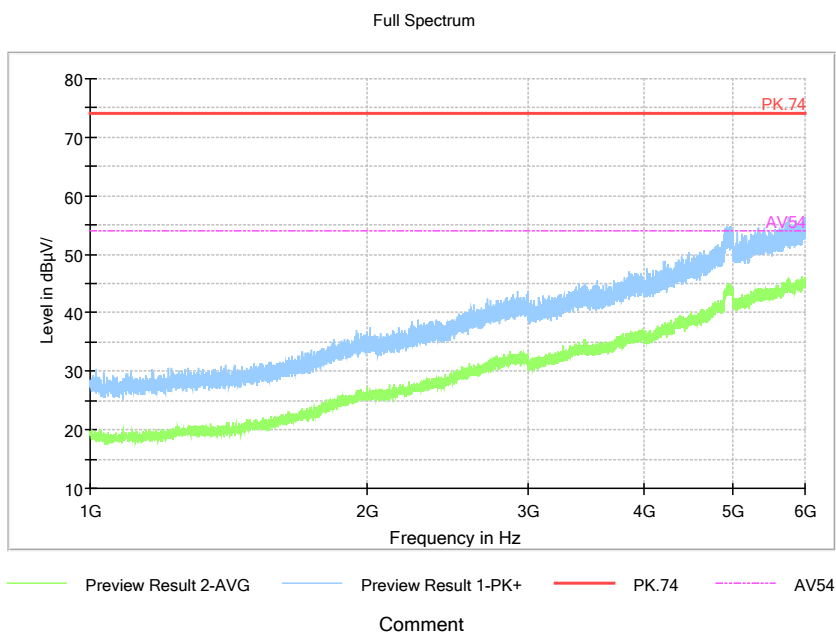

Pic6. Radiated emission (1GHz –6GHz)

Note: The test data in the graph includes two polarizations: horizontal and vertical

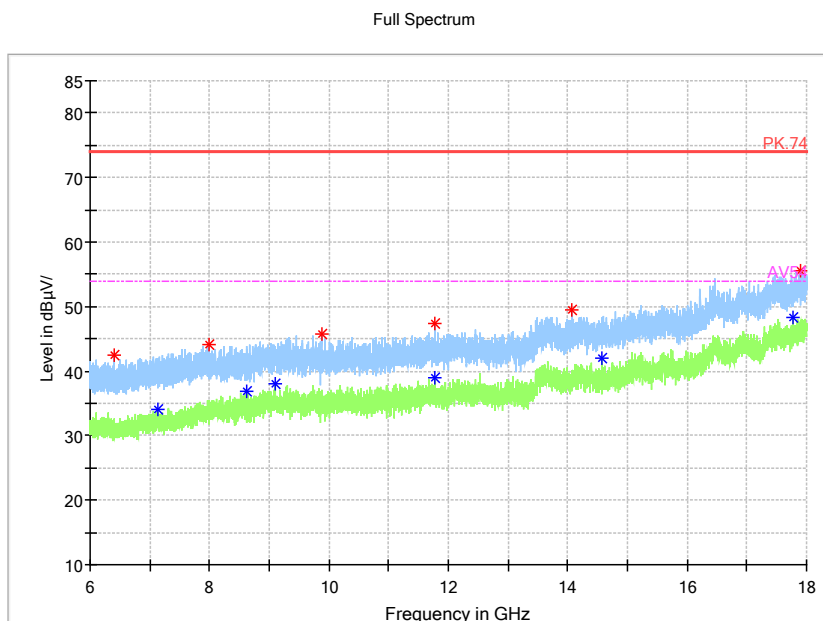

Pic7. Radiated emission (6GHz –18GHz)

Note: The test data in the graph includes two polarizations: horizontal and vertical

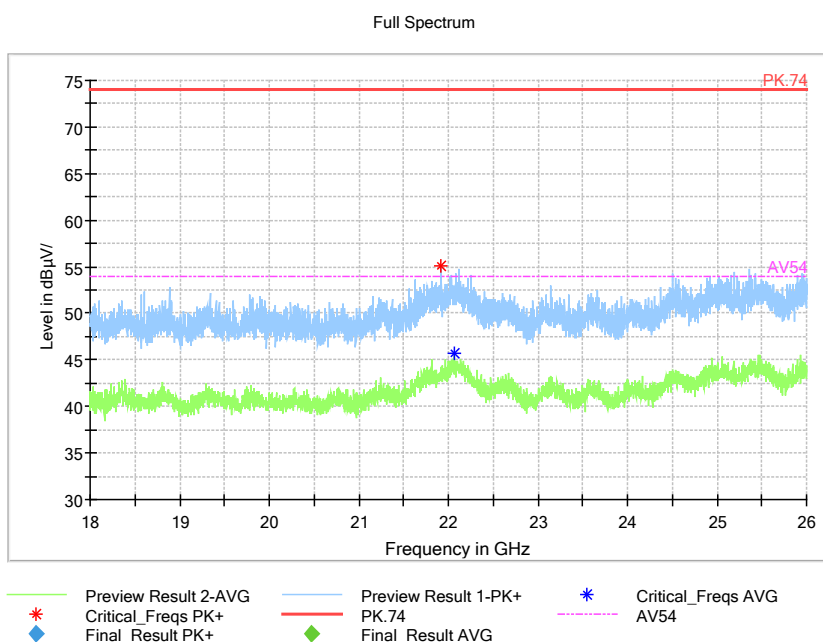

Pic8. Radiated emission (18GHz –26GHz)

Note: The test data in the graph includes two polarizations: horizontal and vertical

EUT1+ Laptop: refer to Pic9 to Pic12

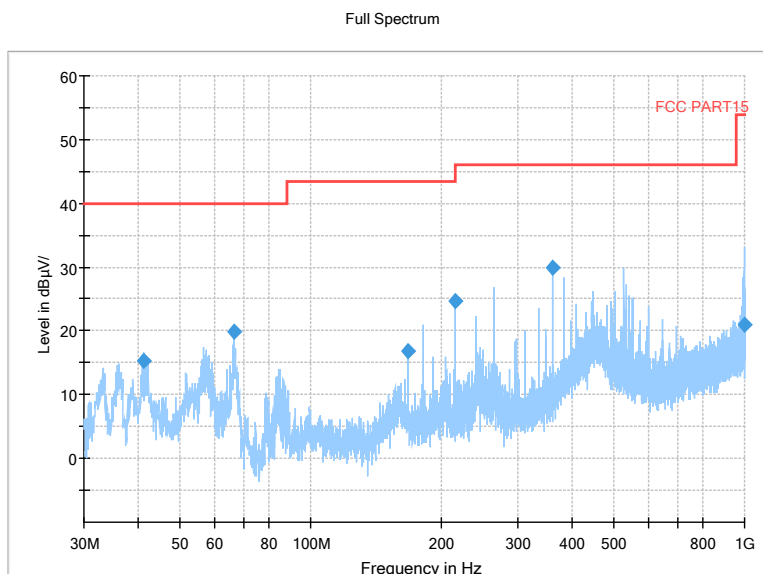

Pic9. Radiated emission (30MHz – 1GHz)

Note: The test data in the graph includes two polarizations: horizontal and vertical

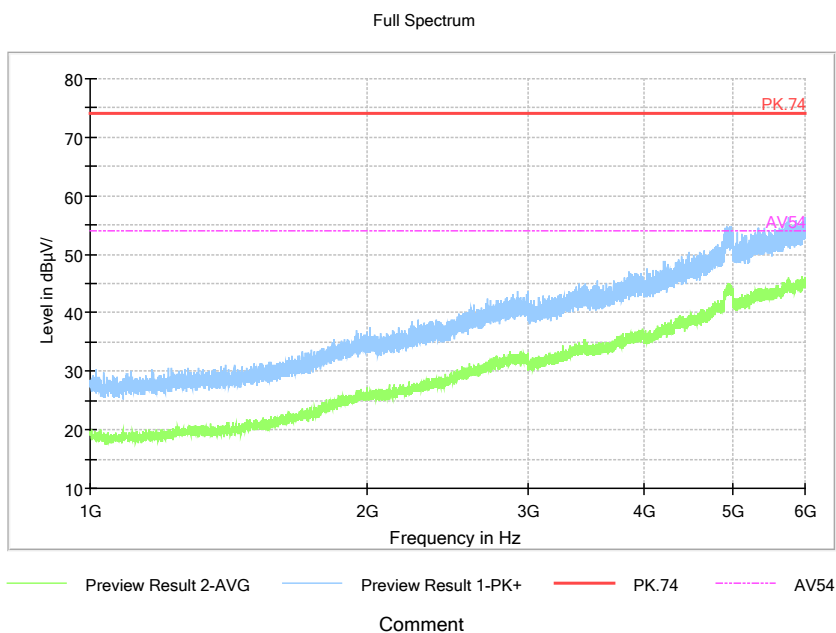

Pic10. Radiated emission (1GHz –6GHz)

Note: The test data in the graph includes two polarizations: horizontal and vertical

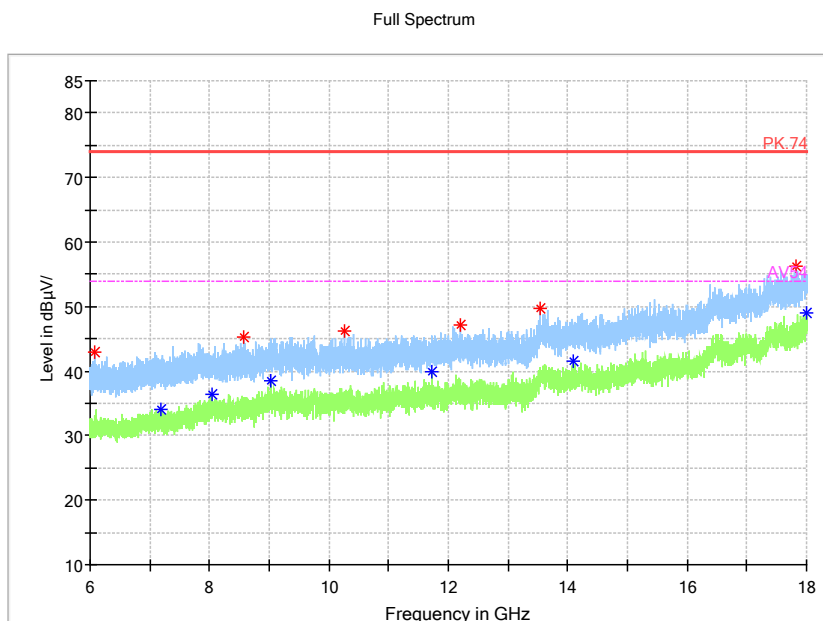

Pic11. Radiated emission (6GHz –18GHz)

Note: The test data in the graph includes two polarizations: horizontal and vertical

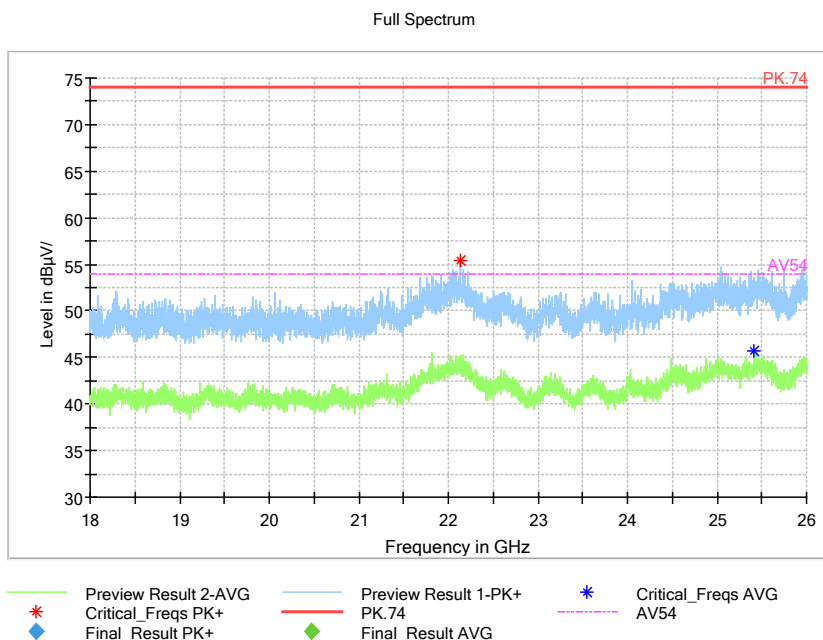

Pic12. Radiated emission (18GHz –26GHz)

Note: The test data in the graph includes two polarizations: horizontal and vertical

2.3. List of test equipments

No.	Name/Model	Manufacturer	S/N	Calibration Due Date	Calibration Date
1	23.18m×16.88m×9.60mS emi-AnechoicChamber	FRANKONIA	-----	5th Sep. 2021	6th Sep. 2016
2	ESW EMI test receiver	R&S	101574	20th Aug. 2021	20th Aug. 2020
3	ESR3 EMI test receiver	R&S	102361	21th Apr. 2021	21th Apr. 2020
4	9.080m×5.255m×3.525m Shielding room	FRANKONIA	-----	5th Sep. 2021	6th Sep. 2016
5	VULB 9163 Ultra log test antenna	schwarzbeck	867	25th Mar. 2021	25th Mar. 2020
6	HF 907 Double-Ridged Waveguide Horn Antenna	R&S	100512	25th Mar. 2021	25th Mar. 2020
7	SAS-574 Horn Antenna	schwarzbeck	535	20th Aug. 2021	20th Aug. 2020
8	ENV216 AMN	R&S	3560.6550. 12	20th Aug. 2021	20th Aug. 2020
9	EMC32EMI test software	R&S	-----	-----	-----

-----The end-----