

**#01\_GSM1900\_GPRS (4 Tx slots)\_Left Cheek\_Ch810**

Communication System: DCS 1900; Frequency: 1909.8 MHz; Duty Cycle: 1:2.08

Medium: HSL\_1900\_200511 Medium parameters used:  $f = 1910$  MHz;  $\sigma = 1.443$  S/m;  $\epsilon_r = 38.729$ ;  $\rho = 1000$  kg/m<sup>3</sup>

Ambient Temperature : 23.5 °C; Liquid Temperature : 22.5 °C

DASY5 Configuration:

- Probe: ES3DV3 - SN3124; ConvF(5.31, 5.31, 5.31) @ 1909.8 MHz; Calibrated: 2019/12/18
- Sensor-Surface: 3mm (Mechanical Surface Detection)
- Electronics: DAE4 Sn316; Calibrated: 2019/12/20
- Phantom: SAM\_Right; Type: QD000P40CD; Serial: TP:1815
- Measurement SW: DASY52, Version 52.10 (4); SEMCAD X Version 14.6.14 (7483)

**Area Scan (61x121x1):** Interpolated grid: dx=1.500 mm, dy=1.500 mm

Maximum value of SAR (interpolated) = 0.171 W/kg

**Zoom Scan (5x5x7)/Cube 0:** Measurement grid: dx=8mm, dy=8mm, dz=5mm

Reference Value = 2.494 V/m; Power Drift = 0.10 dB

Peak SAR (extrapolated) = 0.199 W/kg

**SAR(1 g) = 0.121 W/kg; SAR(10 g) = 0.070 W/kg**

Maximum value of SAR (measured) = 0.160 W/kg

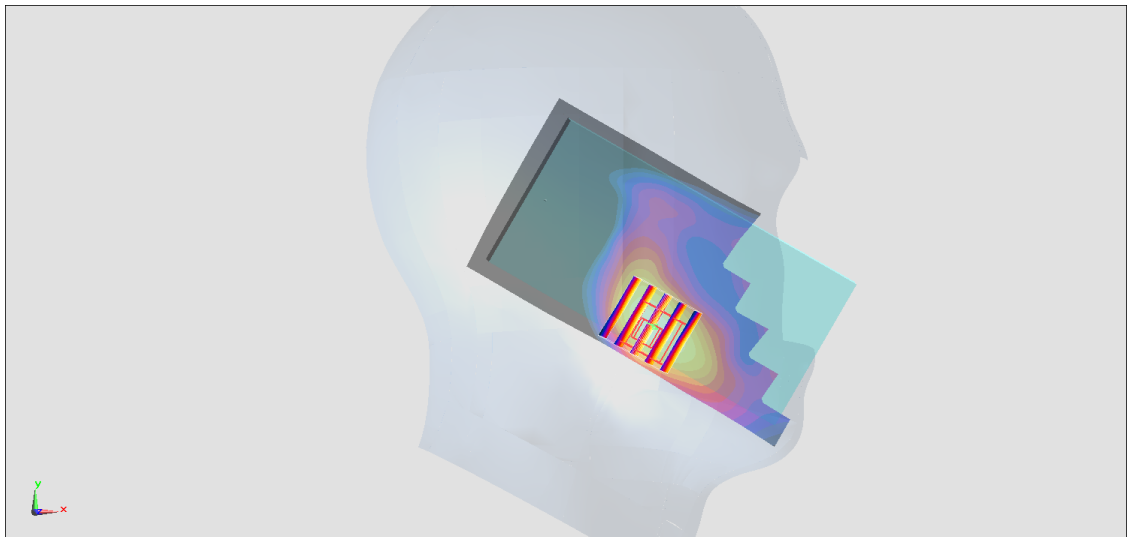
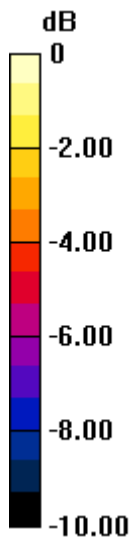

0 dB = 0.171 W/kg = -7.67 dBW/kg

**#02\_WCDMA II\_RMC 12.2Kbps\_Left Cheek\_Ch9538**

Communication System: WCDMA; Frequency: 1907.6 MHz; Duty Cycle: 1:1

Medium: HSL\_1900\_200511 Medium parameters used:  $f = 1908$  MHz;  $\sigma = 1.441$  S/m;  $\epsilon_r = 38.739$ ;  $\rho = 1000$  kg/m<sup>3</sup>

Ambient Temperature : 23.5 °C; Liquid Temperature : 22.5 °C

DASY5 Configuration:

- Probe: ES3DV3 - SN3124; ConvF(5.31, 5.31, 5.31) @ 1907.6 MHz; Calibrated: 2019/12/18
- Sensor-Surface: 3mm (Mechanical Surface Detection)
- Electronics: DAE4 Sn316; Calibrated: 2019/12/20
- Phantom: SAM\_Right; Type: QD000P40CD; Serial: TP:1815
- Measurement SW: DASY52, Version 52.10 (4); SEMCAD X Version 14.6.14 (7483)

**Area Scan (61x121x1):** Interpolated grid: dx=1.500 mm, dy=1.500 mm

Maximum value of SAR (interpolated) = 0.303 W/kg

**Zoom Scan (5x5x7)/Cube 0:** Measurement grid: dx=8mm, dy=8mm, dz=5mm

Reference Value = 3.065 V/m; Power Drift = 0.16 dB

Peak SAR (extrapolated) = 0.378 W/kg

**SAR(1 g) = 0.238 W/kg; SAR(10 g) = 0.144 W/kg**

Maximum value of SAR (measured) = 0.285 W/kg

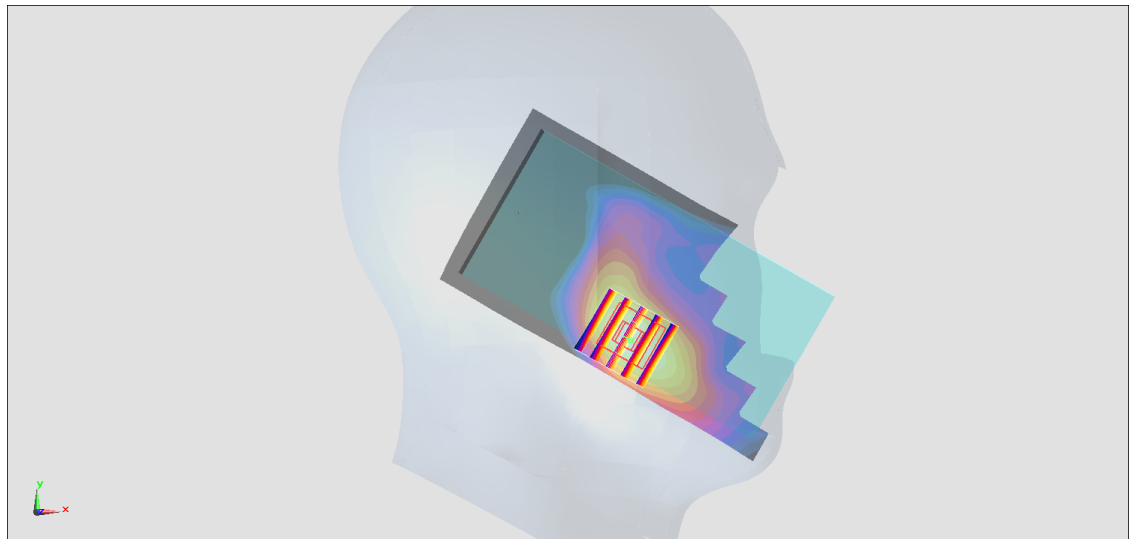
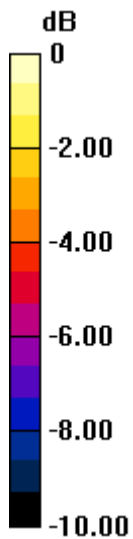

0 dB = 0.303 W/kg = -5.19 dBW/kg

**#03\_WCDMA IV\_RMC 12.2Kbps\_Left Cheek\_Ch1413**

Communication System: WCDMA; Frequency: 1732.6 MHz; Duty Cycle: 1:1

Medium: HSL\_1750\_200511 Medium parameters used:  $f = 1733$  MHz;  $\sigma = 1.356$  S/m;  $\epsilon_r = 41.521$ ;  $\rho = 1000$  kg/m<sup>3</sup>

Ambient Temperature : 23.5 °C ; Liquid Temperature : 22.5 °C

DASY5 Configuration:

- Probe: ES3DV3 - SN3124; ConvF(5.53, 5.53, 5.53) @ 1732.6 MHz; Calibrated: 2019/12/18
- Sensor-Surface: 3mm (Mechanical Surface Detection)
- Electronics: DAE4 Sn316; Calibrated: 2019/12/20
- Phantom: SAM\_Right; Type: QD000P40CD; Serial: TP:1815
- Measurement SW: DASY52, Version 52.10 (4); SEMCAD X Version 14.6.14 (7483)

**Area Scan (61x121x1):** Interpolated grid: dx=1.500 mm, dy=1.500 mm

Maximum value of SAR (interpolated) = 0.171 W/kg

**Zoom Scan (5x5x7)/Cube 0:** Measurement grid: dx=8mm, dy=8mm, dz=5mm

Reference Value = 3.873 V/m; Power Drift = 0.17 dB

Peak SAR (extrapolated) = 0.219 W/kg

**SAR(1 g) = 0.140 W/kg; SAR(10 g) = 0.089 W/kg**

Maximum value of SAR (measured) = 0.165 W/kg

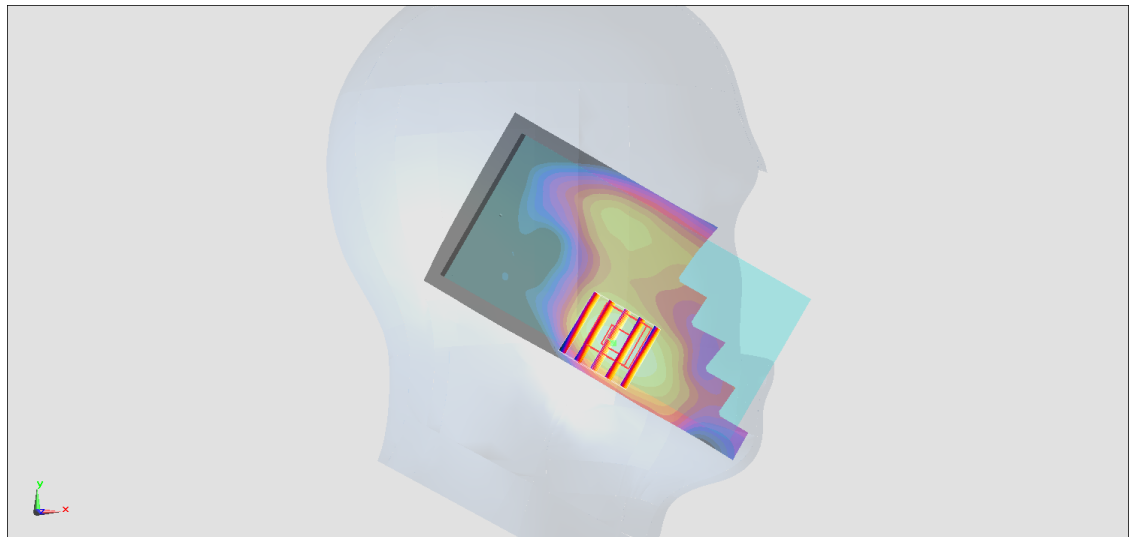
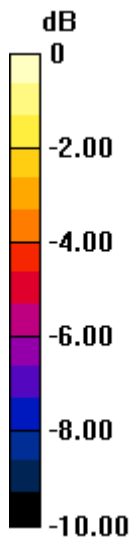

0 dB = 0.171 W/kg = -7.67 dBW/kg

**#04\_WCDMA V\_RMC 12.2Kbps\_Right Cheek\_Ch4233**

Communication System: WCDMA; Frequency: 846.6 MHz; Duty Cycle: 1:1

Medium: HSL\_835\_200522 Medium parameters used:  $f = 847$  MHz;  $\sigma = 0.901$  S/m;  $\epsilon_r = 42.057$ ;  $\rho = 1000$  kg/m<sup>3</sup>

Ambient Temperature : 23.6 °C ; Liquid Temperature : 22.6 °C

DASY5 Configuration:

- Probe: ES3DV3 - SN3124; ConvF(6.28, 6.28, 6.28) @ 846.6 MHz; Calibrated: 2019/12/18
- Sensor-Surface: 3mm (Mechanical Surface Detection)
- Electronics: DAE4 Sn316; Calibrated: 2019/12/20
- Phantom: SAM\_Right; Type: QD000P40CD; Serial: TP:1815
- Measurement SW: DASY52, Version 52.10 (4); SEMCAD X Version 14.6.14 (7483)

**Area Scan (61x121x1):** Interpolated grid: dx=1.500 mm, dy=1.500 mm

Maximum value of SAR (interpolated) = 0.208 W/kg

**Zoom Scan (5x5x7)/Cube 0:** Measurement grid: dx=8mm, dy=8mm, dz=5mm

Reference Value = 3.245 V/m; Power Drift = 0.11 dB

Peak SAR (extrapolated) = 0.260 W/kg

**SAR(1 g) = 0.178 W/kg; SAR(10 g) = 0.135 W/kg**

Maximum value of SAR (measured) = 0.200 W/kg

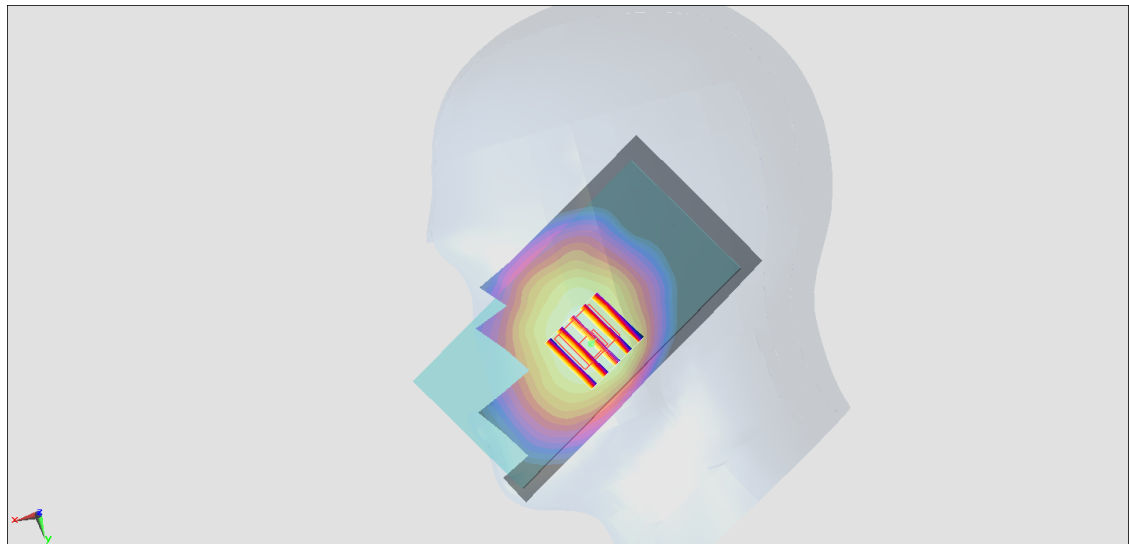
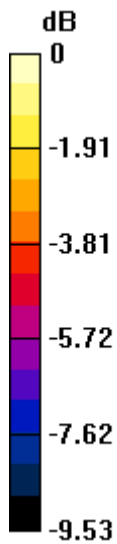

0 dB = 0.200 W/kg = -6.99 dBW/kg

**#05\_LTE Band 2\_20M\_QPSK\_1\_0\_Left Cheek\_Ch19100**

Communication System: LTE; Frequency: 1900 MHz; Duty Cycle: 1:1

Medium: HSL\_1900\_200511 Medium parameters used:  $f = 1900$  MHz;  $\sigma = 1.433$  S/m;  $\epsilon_r = 38.773$ ;  $\rho = 1000$  kg/m<sup>3</sup>

Ambient Temperature : 23.5 °C ; Liquid Temperature : 22.5 °C

DASY5 Configuration:

- Probe: ES3DV3 - SN3124; ConvF(5.31, 5.31, 5.31) @ 1900 MHz; Calibrated: 2019/12/18
- Sensor-Surface: 3mm (Mechanical Surface Detection)
- Electronics: DAE4 Sn316; Calibrated: 2019/12/20
- Phantom: SAM\_Right; Type: QD000P40CD; Serial: TP:1815
- Measurement SW: DASY52, Version 52.10 (4); SEMCAD X Version 14.6.14 (7483)

**Area Scan (61x121x1):** Interpolated grid: dx=1.500 mm, dy=1.500 mm

Maximum value of SAR (interpolated) = 0.205 W/kg

**Zoom Scan (5x5x7)/Cube 0:** Measurement grid: dx=8mm, dy=8mm, dz=5mm

Reference Value = 2.315 V/m; Power Drift = 0.11 dB

Peak SAR (extrapolated) = 0.265 W/kg

**SAR(1 g) = 0.166 W/kg; SAR(10 g) = 0.099 W/kg**

Maximum value of SAR (measured) = 0.201 W/kg

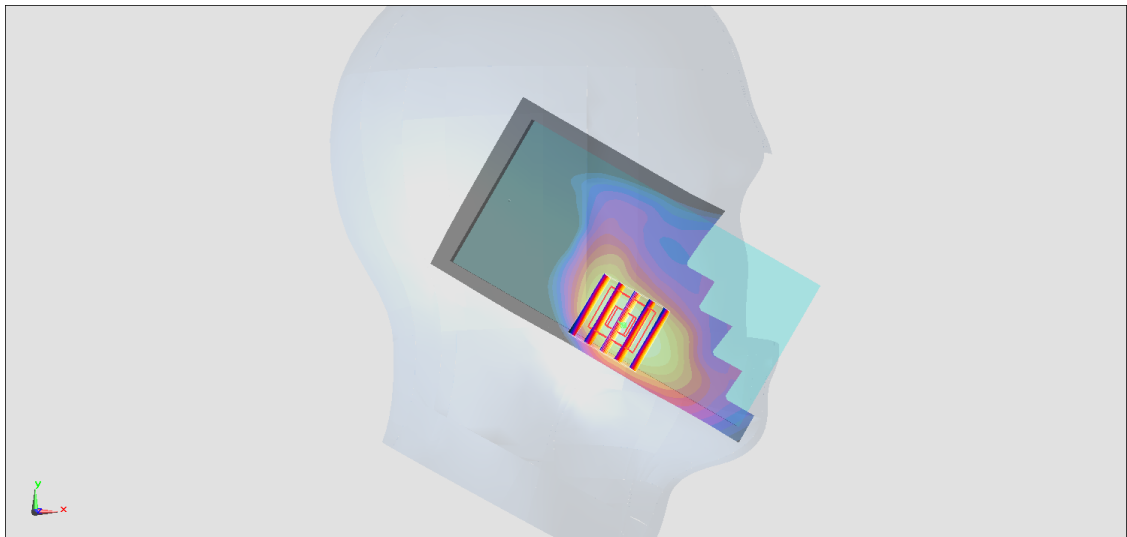
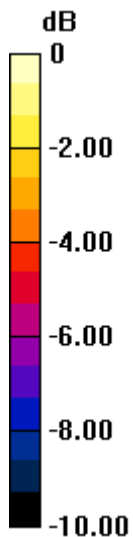

0 dB = 0.205 W/kg = -6.88 dBW/kg

**#06\_LTE Band 4\_20M\_QPSK\_1\_0\_Left Cheek\_Ch20175**

Communication System: LTE; Frequency: 1732.5 MHz; Duty Cycle: 1:1

Medium: HSL\_1750\_200511 Medium parameters used:  $f = 1733$  MHz;  $\sigma = 1.356$  S/m;  $\epsilon_r = 41.521$ ;  $\rho = 1000$  kg/m<sup>3</sup>

Ambient Temperature : 23.5 °C ; Liquid Temperature : 22.5 °C

DASY5 Configuration:

- Probe: ES3DV3 - SN3124; ConvF(5.53, 5.53, 5.53) @ 1732.5 MHz; Calibrated: 2019/12/18
- Sensor-Surface: 3mm (Mechanical Surface Detection)
- Electronics: DAE4 Sn316; Calibrated: 2019/12/20
- Phantom: SAM\_Right; Type: QD000P40CD; Serial: TP:1815
- Measurement SW: DASY52, Version 52.10 (4); SEMCAD X Version 14.6.14 (7483)

**Area Scan (61x121x1):** Interpolated grid: dx=1.500 mm, dy=1.500 mm

Maximum value of SAR (interpolated) = 0.130 W/kg

**Zoom Scan (5x5x7)/Cube 0:** Measurement grid: dx=8mm, dy=8mm, dz=5mm

Reference Value = 3.214 V/m; Power Drift = 0.16 dB

Peak SAR (extrapolated) = 0.159 W/kg

**SAR(1 g) = 0.106 W/kg; SAR(10 g) = 0.069 W/kg**

Maximum value of SAR (measured) = 0.123 W/kg

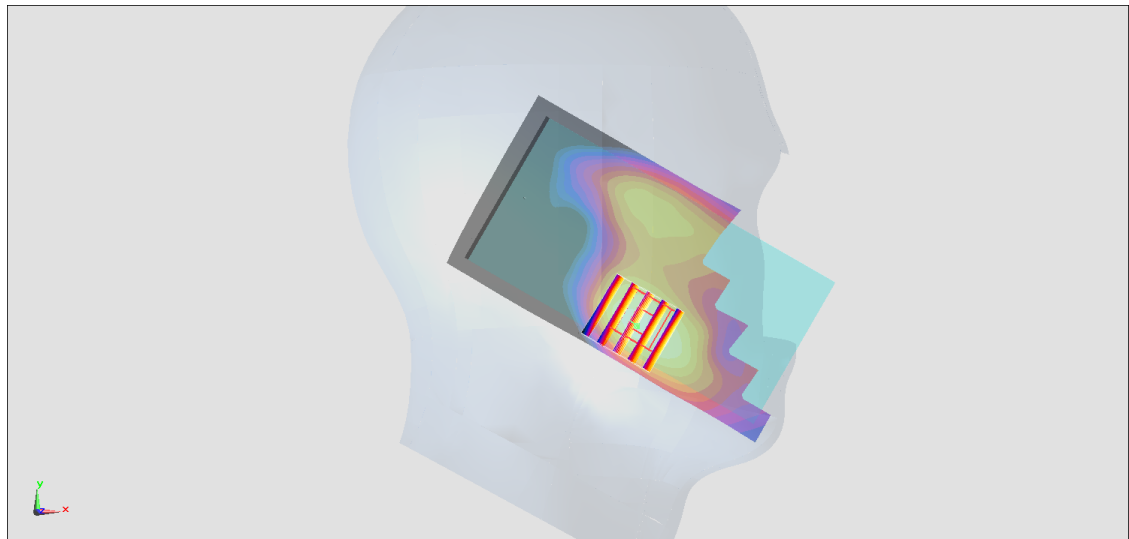
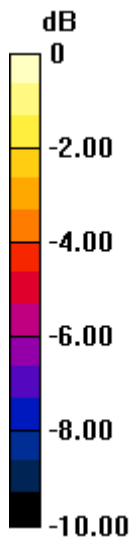

0 dB = 0.130 W/kg = -8.86 dBW/kg

**#07\_LTE Band 5\_10M\_QPSK\_1\_0\_Right Cheek\_Ch20525**

Communication System: LTE; Frequency: 836.5 MHz; Duty Cycle: 1:1

Medium: HSL\_835\_200522 Medium parameters used :  $f = 836.5$  MHz;  $\sigma = 0.891$  S/m;  $\epsilon_r = 42.197$ ;  $\rho = 1000$  kg/m<sup>3</sup>

Ambient Temperature : 23.6 °C ; Liquid Temperature : 22.6 °C

DASY5 Configuration:

- Probe: ES3DV3 - SN3124; ConvF(6.28, 6.28, 6.28) @ 836.5 MHz; Calibrated: 2019/12/18
- Sensor-Surface: 3mm (Mechanical Surface Detection)
- Electronics: DAE4 Sn316; Calibrated: 2019/12/20
- Phantom: SAM\_Right; Type: QD000P40CD; Serial: TP:1815
- Measurement SW: DASY52, Version 52.10 (4); SEMCAD X Version 14.6.14 (7483)

**Area Scan (61x121x1):** Interpolated grid: dx=1.500 mm, dy=1.500 mm

Maximum value of SAR (interpolated) = 0.125 W/kg

**Zoom Scan (5x5x7)/Cube 0:** Measurement grid: dx=8mm, dy=8mm, dz=5mm

Reference Value = 3.456 V/m; Power Drift = 0.16 dB

Peak SAR (extrapolated) = 0.157 W/kg

**SAR(1 g) = 0.115 W/kg; SAR(10 g) = 0.085 W/kg**

Maximum value of SAR (measured) = 0.129 W/kg

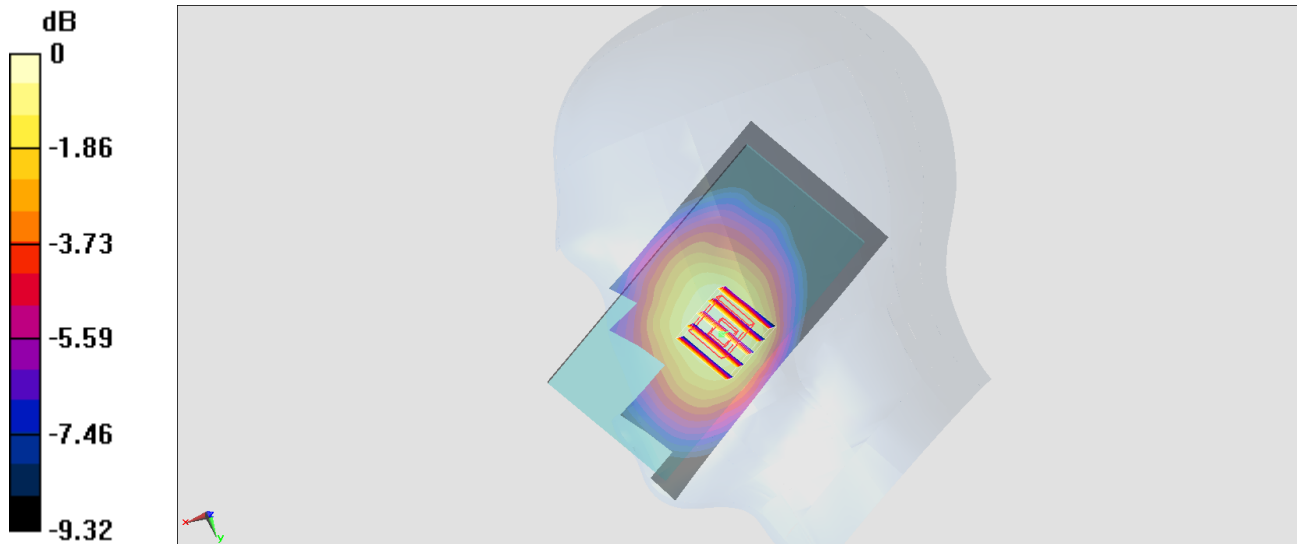

**#08\_WLAN2.4GHz\_802.11b 1Mbps\_Left Cheek\_Ch11**

Communication System: 802.11b ; Frequency: 2462 MHz;Duty Cycle: 1:1.024

Medium: HSL\_2450\_200522 Medium parameters used:  $f = 2462$  MHz;  $\sigma = 1.817$  S/m;  $\epsilon_r = 37.869$ ;  $\rho = 1000$  kg/m<sup>3</sup>

Ambient Temperature : 23.2 °C ; Liquid Temperature : 22.2 °C

DASY5 Configuration:

- Probe: ES3DV3 - SN3124; ConvF(4.64, 4.64, 4.64) @ 2462 MHz; Calibrated: 2019/12/18
- Sensor-Surface: 3mm (Mechanical Surface Detection)
- Electronics: DAE4 Sn316; Calibrated: 2019/12/20
- Phantom: SAM\_Right; Type: SAM; Serial: TP-1303
- Measurement SW: DASY52, Version 52.10 (4);SEMCAD X Version 14.6.14 (7483)

**Area Scan (71x161x1):** Interpolated grid: dx=1.200 mm, dy=1.200 mm

Maximum value of SAR (interpolated) = 0.0628 W/kg

**Zoom Scan (7x7x7)/Cube 0:** Measurement grid: dx=5mm, dy=5mm, dz=5mm

Reference Value = 2.362 V/m; Power Drift = 0.12 dB

Peak SAR (extrapolated) = 0.0980 W/kg

**SAR(1 g) = 0.051 W/kg; SAR(10 g) = 0.028 W/kg**

Maximum value of SAR (measured) = 0.0638 W/kg

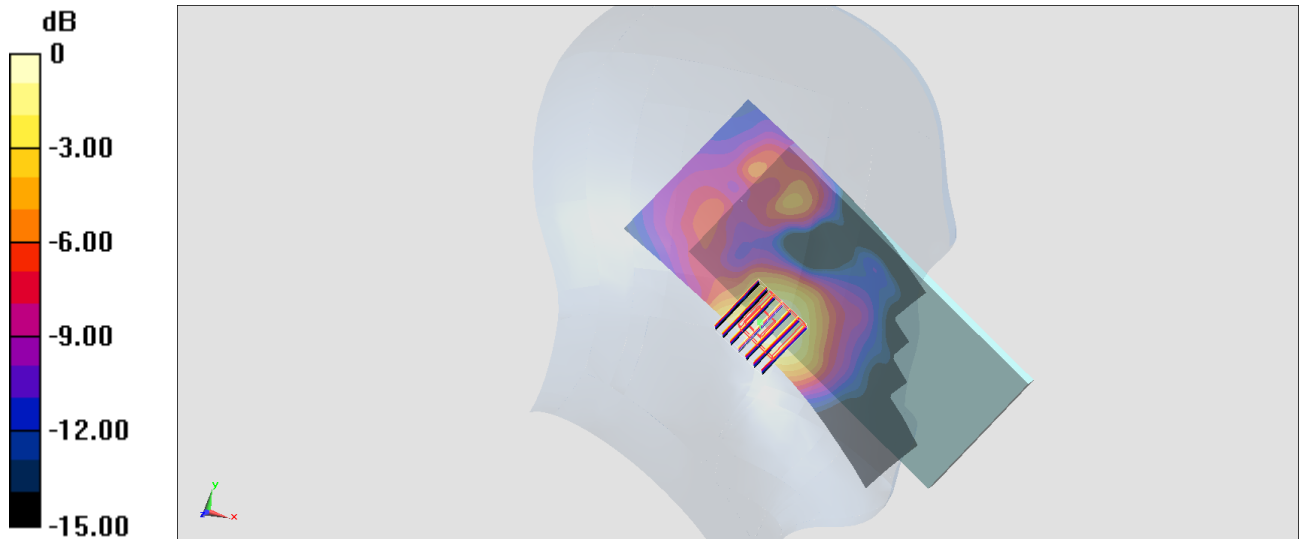

0 dB = 0.0628 W/kg = -12.02 dBW/kg



**#09\_WLAN5GHz\_802.11ac-VHT80 MCS0\_Left Cheek\_Ch58**

Communication System: 802.11ac; Frequency: 5290 MHz; Duty Cycle: 1:1.159

Medium: HSL\_5G\_200523 Medium parameters used :  $f = 5290$  MHz;  $\sigma = 4.716$  S/m;  $\epsilon_r = 36.561$ ;  $\rho = 1000$  kg/m<sup>3</sup>

Ambient Temperature : 23.3 °C; Liquid Temperature : 22.3 °C

DASY5 Configuration:

- Probe: EX3DV4 - SN3642; ConvF(4.43, 4.43, 4.43) @ 5290 MHz; Calibrated: 2020/4/29
- Sensor-Surface: 1.4mm (Mechanical Surface Detection)
- Electronics: DAE4 Sn913; Calibrated: 2020/5/6
- Phantom: SAM\_Left; Type: QD000P40CD; Serial: TP:1801
- Measurement SW: DASY52, Version 52.10 (4); SEMCAD X Version 14.6.14 (7483)

**Area Scan (121x181x1):** Interpolated grid: dx=1.000 mm, dy=1.000 mm

Maximum value of SAR (interpolated) = 0.0318 W/kg

**Zoom Scan (7x7x7)/Cube 0:** Measurement grid: dx=4mm, dy=4mm, dz=1.4mm

Reference Value = 0 V/m; Power Drift = 0.1 dB

Peak SAR (extrapolated) = 0.541 W/kg

**SAR(1 g) = 0.041 W/kg; SAR(10 g) = 0.00786 W/kg**

Maximum value of SAR (measured) = 0.0486 W/kg

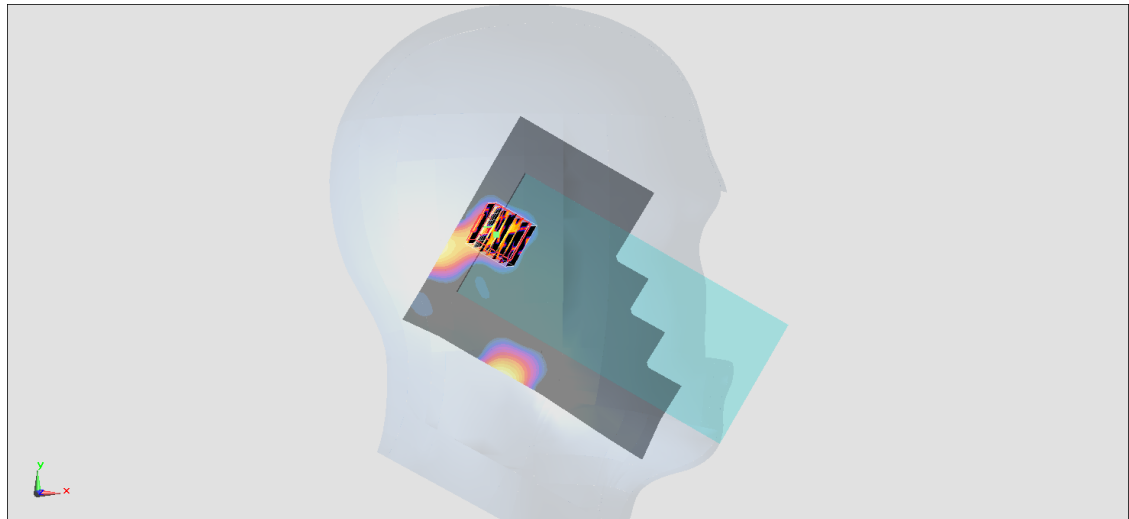
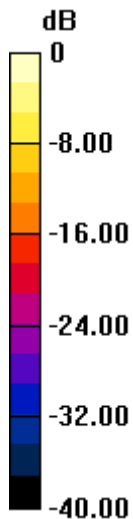

0 dB = 0.0486 W/kg = -13.13 dBW/kg

**#10\_WLAN5GHz\_802.11ac-VHT80 MCS0\_Right Tilted\_Ch122**

Communication System: 802.11ac ; Frequency: 5610 MHz;Duty Cycle: 1:1.159

Medium: HSL\_5G\_200523 Medium parameters used :  $f = 5610$  MHz;  $\sigma = 5.069$  S/m;  $\epsilon_r = 36.425$ ;  $\rho = 1000$  kg/m<sup>3</sup>

Ambient Temperature : 23.3 °C ; Liquid Temperature : 22.3 °C

DASY5 Configuration:

- Probe: EX3DV4 - SN3642;ConvF(4.19, 4.19, 4.19) @ 5610 MHz;Calibrated: 2020/4/29
- Sensor-Surface: 1.4mm (Mechanical Surface Detection)
- Electronics: DAE4 Sn913; Calibrated: 2020/5/6
- Phantom: SAM\_Left; Type: QD000P40CD; Serial: TP:1801
- Measurement SW: DASY52, Version 52.10 (4);SEMCAD X Version 14.6.14 (7483)

**Area Scan (121x141x1):** Interpolated grid: dx=1.000 mm, dy=1.000 mm

Maximum value of SAR (interpolated) = 0.245 W/kg

**Zoom Scan (7x7x7)/Cube 0:** Measurement grid: dx=4mm, dy=4mm, dz=1.4mm

Reference Value = 0 V/m; Power Drift = 0.11 dB

Peak SAR (extrapolated) = 0.261 W/kg

**SAR(1 g) = 0.033 W/kg; SAR(10 g) = 0.00953 W/kg**

Maximum value of SAR (measured) = 0.140 W/kg

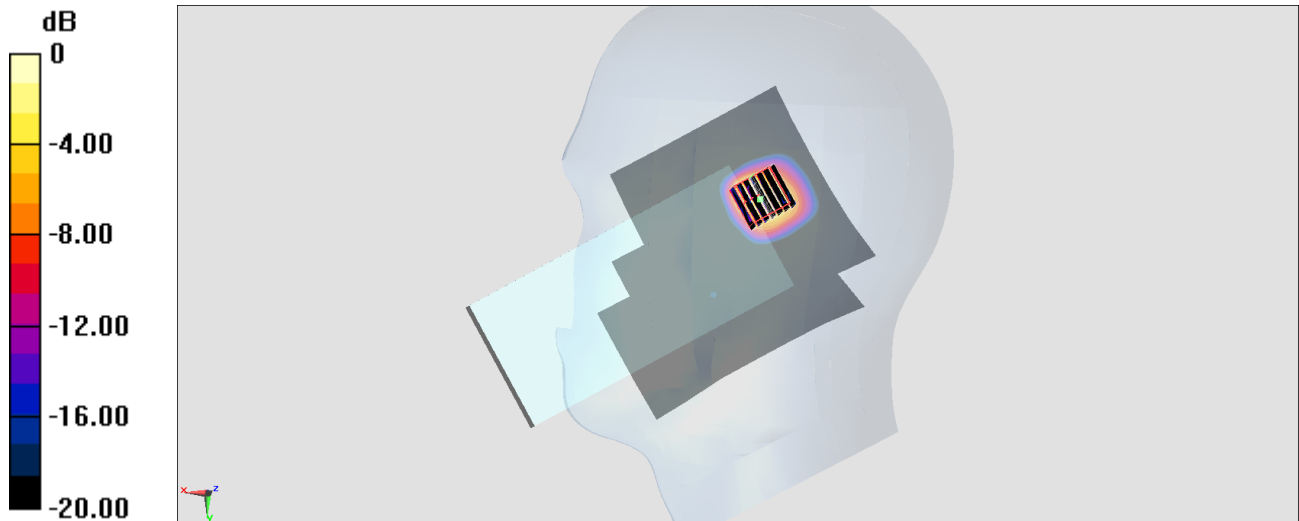

0 dB = 0.140 W/kg = -8.54 dBW/kg

## #11\_Bluetooth\_1Mbps\_Left Cheek\_Ch39

Communication System: Bluetooth ; Frequency: 2441 MHz;Duty Cycle: 1:1.304

Medium: HSL\_2450\_200527 Medium parameters used :  $f = 2441$  MHz;  $\sigma = 1.853$  S/m;  $\epsilon_r = 39.281$ ;  $\rho = 1000$  kg/m<sup>3</sup>

Ambient Temperature : 23.4 °C ; Liquid Temperature : 22.4 °C

DASY5 Configuration:

- Probe: EX3DV4 - SN7306; ConvF(7.48, 7.48, 7.48) @ 2441 MHz; Calibrated: 2019/7/22
- Sensor-Surface: 1.4mm (Mechanical Surface Detection)
- Electronics: DAE4 Sn679; Calibrated: 2020/5/6
- Phantom: SAM\_Left; Type: QD000P40CD; Serial: TP:1815
- Measurement SW: DASY52, Version 52.10 (4);SEMCAD X Version 14.6.14 (7483)

**Area Scan (91x161x1):** Interpolated grid: dx=1.200 mm, dy=1.200 mm

Maximum value of SAR (interpolated) = 0.0200 W/kg

**Zoom Scan (7x7x7)/Cube 0:** Measurement grid: dx=5mm, dy=5mm, dz=5mm

Reference Value = 0.988 V/m; Power Drift = -0.12 dB

Peak SAR (extrapolated) = 0.0230 W/kg

**SAR(1 g) = 0.013 W/kg; SAR(10 g) = 0.00613 W/kg**

Maximum value of SAR (measured) = 0.0194 W/kg

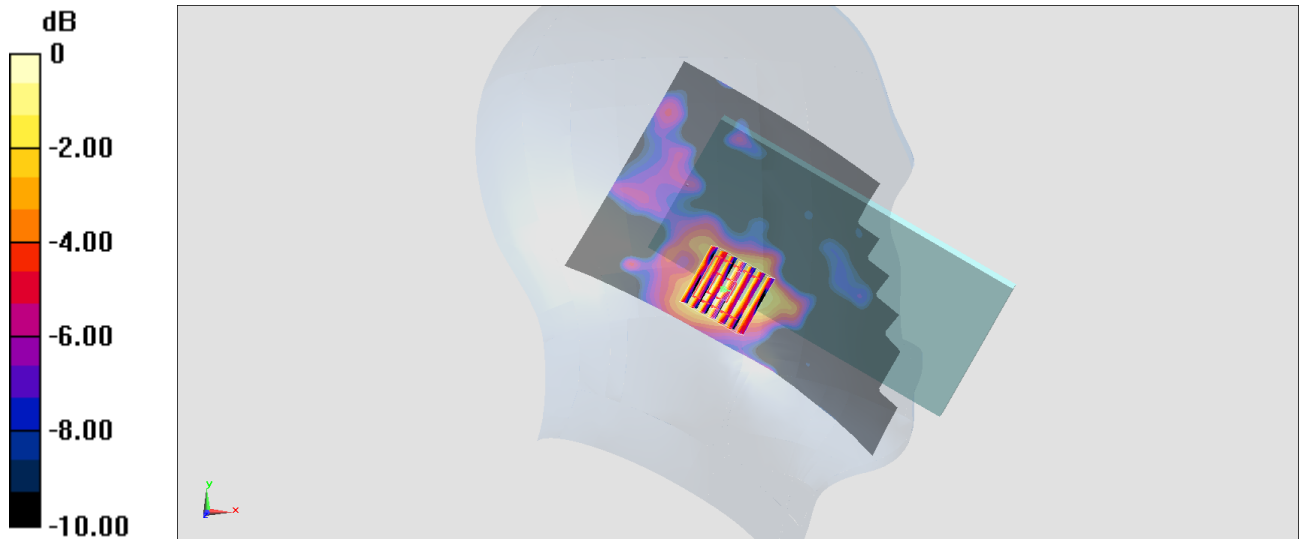

0 dB = 0.0200 W/kg = -16.99 dBW/kg

**#12\_GSM1900\_GPRS (4 Tx slots)\_Bottom Side\_10mm\_Ch661**

Communication System: PCS 1900; Frequency: 1880 MHz; Duty Cycle: 1:2.08

Medium: HSL\_1900\_200521 Medium parameters used:  $f = 1880$  MHz;  $\sigma = 1.398$  S/m;  $\epsilon_r = 38.74$ ;  $\rho = 1000$  kg/m<sup>3</sup>

Ambient Temperature : 23.6 °C ; Liquid Temperature : 22.6 °C

DASY5 Configuration:

- Probe: ES3DV3 - SN3124; ConvF(5.31, 5.31, 5.31) @ 1880 MHz; Calibrated: 2019/12/18
- Sensor-Surface: 3mm (Mechanical Surface Detection)
- Electronics: DAE4 Sn316; Calibrated: 2019/12/20
- Phantom: SAM\_Right; Type: QD000P40CD; Serial: TP:1815
- Measurement SW: DASY52, Version 52.10 (4); SEMCAD X Version 14.6.14 (7483)

**Area Scan (41x71x1):** Interpolated grid: dx=1.500 mm, dy=1.500 mm

Maximum value of SAR (interpolated) = 1.07 W/kg

**Zoom Scan (5x5x7)/Cube 0:** Measurement grid: dx=8mm, dy=8mm, dz=5mm

Reference Value = 27.90 V/m; Power Drift = -0.10 dB

Peak SAR (extrapolated) = 1.52 W/kg

**SAR(1 g) = 0.797 W/kg; SAR(10 g) = 0.403 W/kg**

Maximum value of SAR (measured) = 1.03 W/kg

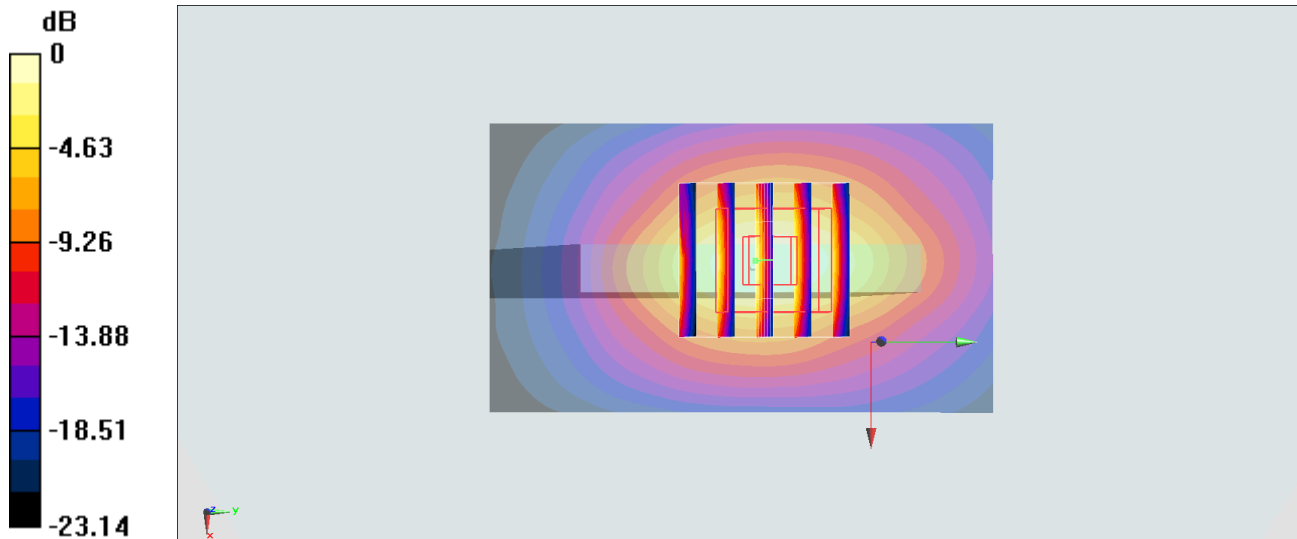

0 dB = 1.07 W/kg = 0.29 dBW/kg

**#13\_WCDMA II\_RMC 12.2Kbps\_Bottom Side\_10mm\_Ch9538**

Communication System: WCDMA; Frequency: 1907.6 MHz; Duty Cycle: 1:1

Medium: HSL\_1900\_200521 Medium parameters used:  $f = 1908$  MHz;  $\sigma = 1.427$  S/m;  $\epsilon_r = 38.608$ ;  $\rho = 1000$  kg/m<sup>3</sup>

Ambient Temperature : 23.6 °C; Liquid Temperature : 22.6 °C

DASY5 Configuration:

- Probe: ES3DV3 - SN3124; ConvF(5.31, 5.31, 5.31) @ 1907.6 MHz; Calibrated: 2019/12/18
- Sensor-Surface: 3mm (Mechanical Surface Detection)
- Electronics: DAE4 Sn316; Calibrated: 2019/12/20
- Phantom: SAM\_Right; Type: QD000P40CD; Serial: TP:1815
- Measurement SW: DASY52, Version 52.10 (4); SEMCAD X Version 14.6.14 (7483)

**Area Scan (41x81x1):** Interpolated grid: dx=1.500 mm, dy=1.500 mm

Maximum value of SAR (interpolated) = 0.960 W/kg

**Zoom Scan (5x5x7)/Cube 0:** Measurement grid: dx=8mm, dy=8mm, dz=5mm

Reference Value = 25.79 V/m; Power Drift = 0.00 dB

Peak SAR (extrapolated) = 1.27 W/kg

**SAR(1 g) = 0.723 W/kg; SAR(10 g) = 0.373 W/kg**

Maximum value of SAR (measured) = 0.916 W/kg

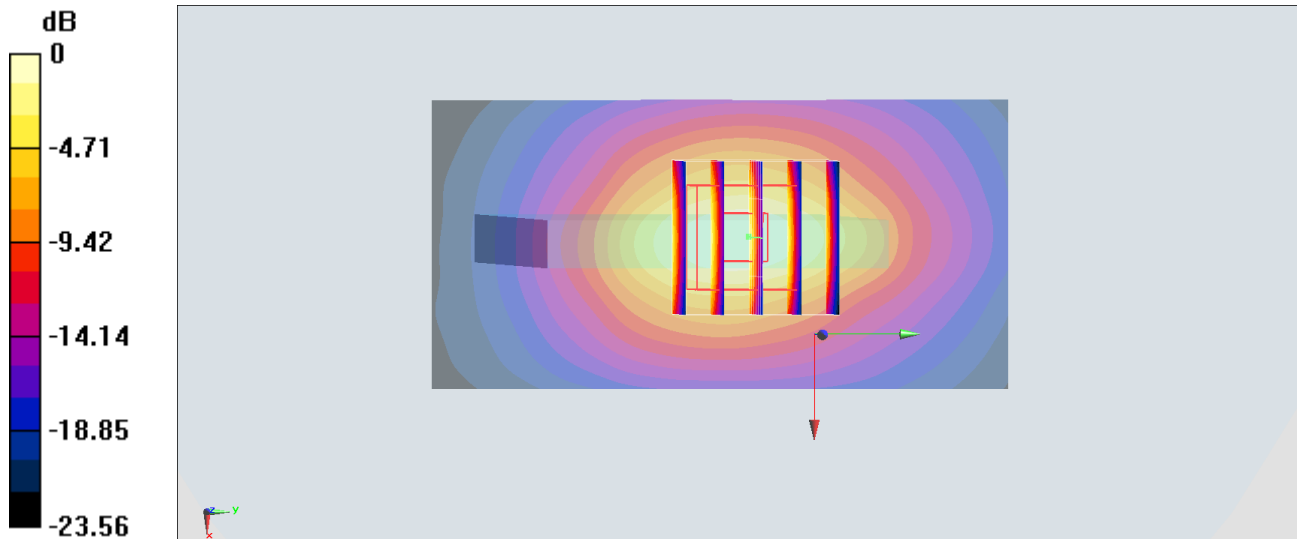

0 dB = 0.960 W/kg = -0.18 dBW/kg

**#14\_WCDMA IV\_RMC 12.2Kbps\_Bottom Side\_10mm\_Ch1413**

Communication System: WCDMA; Frequency: 1732.6 MHz; Duty Cycle: 1:1

Medium: HSL\_1750\_200521 Medium parameters used:  $f = 1733$  MHz;  $\sigma = 1.363$  S/m;  $\epsilon_r = 41.328$ ;  $\rho = 1000$  kg/m<sup>3</sup>

Ambient Temperature : 23.6 °C ; Liquid Temperature : 22.6 °C

DASY5 Configuration:

- Probe: ES3DV3 - SN3124; ConvF(5.53, 5.53, 5.53) @ 1732.6 MHz; Calibrated: 2019/12/18
- Sensor-Surface: 3mm (Mechanical Surface Detection)
- Electronics: DAE4 Sn316; Calibrated: 2019/12/20
- Phantom: SAM\_Right; Type: QD000P40CD; Serial: TP:1815
- Measurement SW: DASY52, Version 52.10 (4); SEMCAD X Version 14.6.14 (7483)

**Area Scan (41x81x1):** Interpolated grid: dx=1.500 mm, dy=1.500 mm

Maximum value of SAR (interpolated) = 0.955 W/kg

**Zoom Scan (5x5x7)/Cube 0:** Measurement grid: dx=8mm, dy=8mm, dz=5mm

Reference Value = 26.80 V/m; Power Drift = -0.07 dB

Peak SAR (extrapolated) = 1.33 W/kg

**SAR(1 g) = 0.732 W/kg; SAR(10 g) = 0.370 W/kg**

Maximum value of SAR (measured) = 0.921 W/kg

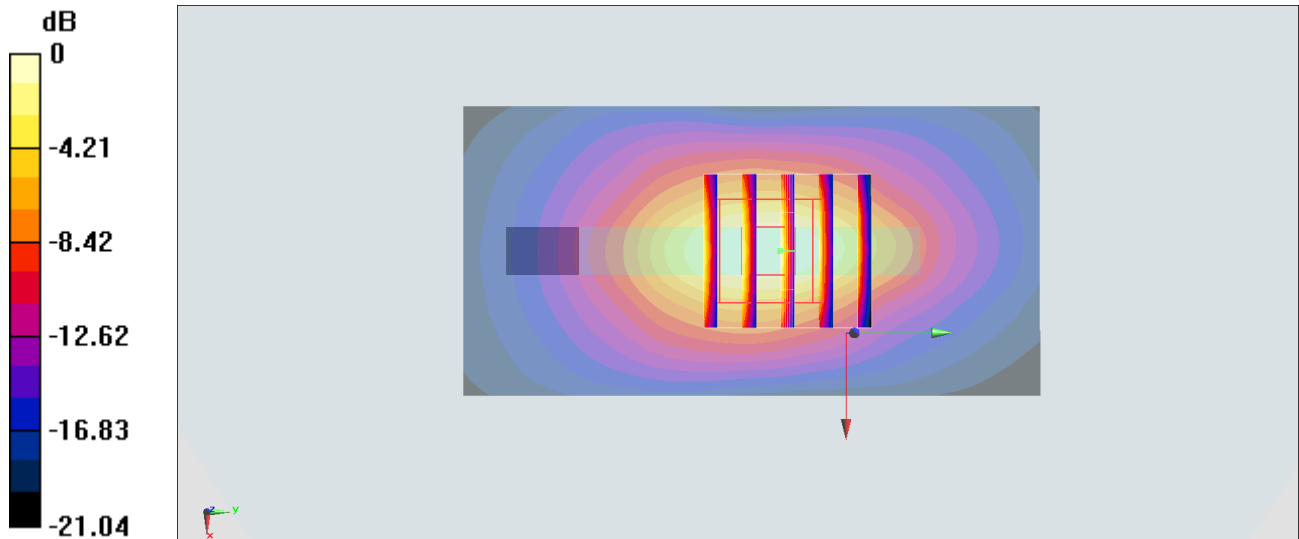

0 dB = 0.955 W/kg = -0.20 dBW/kg

**#15\_WCDMA V\_RMC 12.2Kbps\_Front\_10mm\_Ch4233**

Communication System: WCDMA; Frequency: 846.6 MHz; Duty Cycle: 1:1

Medium: HSL\_835\_200512 Medium parameters used:  $f = 847$  MHz;  $\sigma = 0.907$  S/m;  $\epsilon_r = 40.854$ ;  $\rho = 1000$  kg/m<sup>3</sup>

Ambient Temperature : 23.6 °C ; Liquid Temperature : 22.6 °C

DASY5 Configuration:

- Probe: ES3DV3 - SN3124; ConvF(6.28, 6.28, 6.28) @ 846.6 MHz; Calibrated: 2019/12/18
- Sensor-Surface: 3mm (Mechanical Surface Detection)
- Electronics: DAE4 Sn316; Calibrated: 2019/12/20
- Phantom: SAM\_Right; Type: QD000P40CD; Serial: TP:1815
- Measurement SW: DASY52, Version 52.10 (4); SEMCAD X Version 14.6.14 (7483)

**Area Scan (61x121x1):** Interpolated grid: dx=1.500 mm, dy=1.500 mm

Maximum value of SAR (interpolated) = 0.326 W/kg

**Zoom Scan (5x5x7)/Cube 0:** Measurement grid: dx=8mm, dy=8mm, dz=5mm

Reference Value = 18.82 V/m; Power Drift = 0.09 dB

Peak SAR (extrapolated) = 0.461 W/kg

**SAR(1 g) = 0.259 W/kg; SAR(10 g) = 0.152 W/kg**

Maximum value of SAR (measured) = 0.322 W/kg

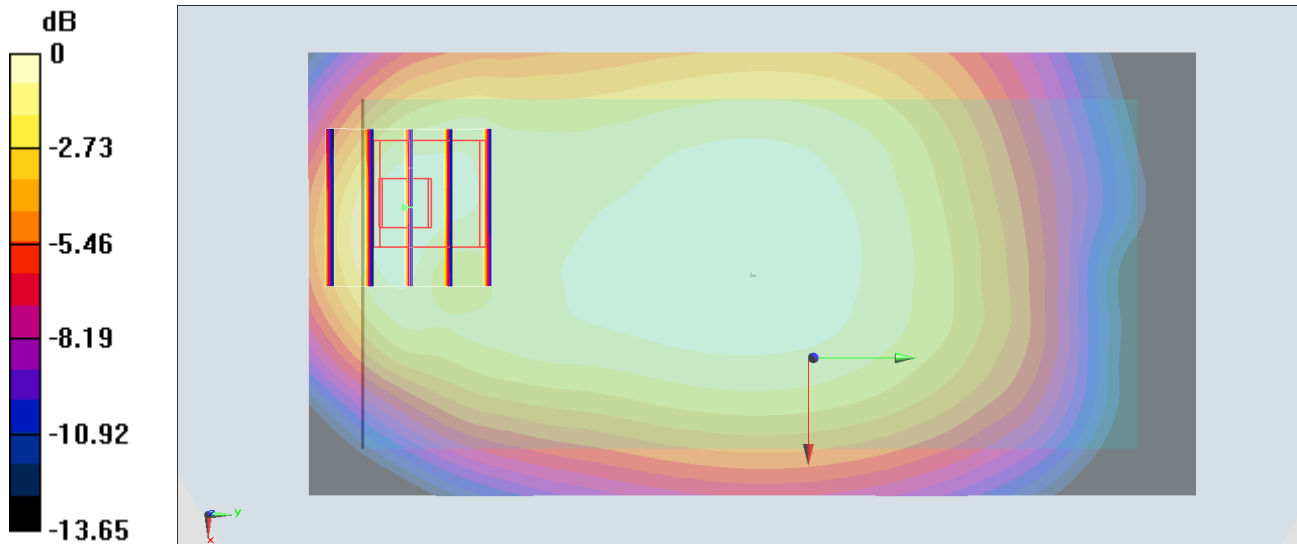

**#16\_LTE Band 2\_20M\_QPSK\_1\_0\_Bottom Side\_10mm\_Ch19100**

Communication System: LTE; Frequency: 1900 MHz; Duty Cycle: 1:1

Medium: HSL\_1900\_200521 Medium parameters used:  $f = 1900$  MHz;  $\sigma = 1.42$  S/m;  $\epsilon_r = 38.642$ ;  $\rho = 1000$  kg/m<sup>3</sup>

Ambient Temperature : 23.6 °C ; Liquid Temperature : 22.6 °C

DASY5 Configuration:

- Probe: ES3DV3 - SN3124; ConvF(5.31, 5.31, 5.31) @ 1900 MHz; Calibrated: 2019/12/18
- Sensor-Surface: 3mm (Mechanical Surface Detection)
- Electronics: DAE4 Sn316; Calibrated: 2019/12/20
- Phantom: SAM\_Right; Type: QD000P40CD; Serial: TP:1815
- Measurement SW: DASY52, Version 52.10 (4); SEMCAD X Version 14.6.14 (7483)

**Area Scan (41x71x1):** Interpolated grid: dx=1.500 mm, dy=1.500 mm

Maximum value of SAR (interpolated) = 0.937 W/kg

**Zoom Scan (5x5x7)/Cube 0:** Measurement grid: dx=8mm, dy=8mm, dz=5mm

Reference Value = 25.24 V/m; Power Drift = 0.12 dB

Peak SAR (extrapolated) = 1.20 W/kg

**SAR(1 g) = 0.672 W/kg; SAR(10 g) = 0.349 W/kg**

Maximum value of SAR (measured) = 0.833 W/kg

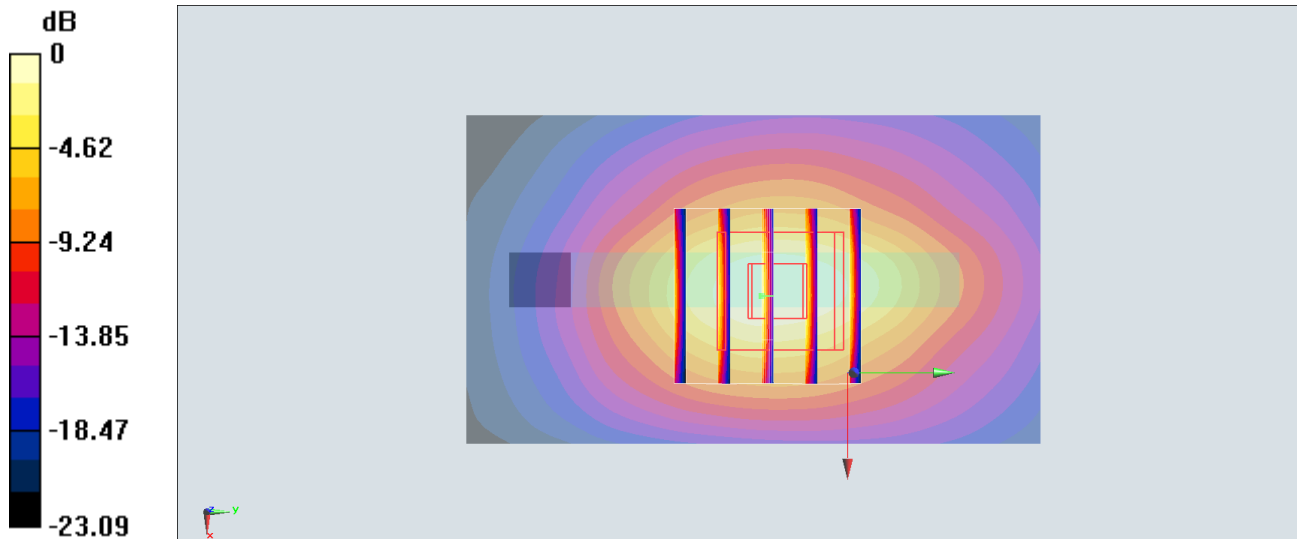

0 dB = 0.937 W/kg = -0.28 dBW/kg



**#17\_LTE Band 4\_20M\_QPSK\_1\_0\_Bottom Side\_10mm\_Ch20175**

Communication System: LTE; Frequency: 1732.5 MHz; Duty Cycle: 1:1

Medium: HSL\_1750\_200521 Medium parameters used:  $f = 1733$  MHz;  $\sigma = 1.363$  S/m;  $\epsilon_r = 41.328$ ;  $\rho = 1000$  kg/m<sup>3</sup>

Ambient Temperature : 23.6 °C ; Liquid Temperature : 22.6 °C

DASY5 Configuration:

- Probe: ES3DV3 - SN3124; ConvF(5.53, 5.53, 5.53) @ 1732.5 MHz; Calibrated: 2019/12/18
- Sensor-Surface: 3mm (Mechanical Surface Detection)
- Electronics: DAE4 Sn316; Calibrated: 2019/12/20
- Phantom: SAM\_Right; Type: QD000P40CD; Serial: TP:1815
- Measurement SW: DASY52, Version 52.10 (4); SEMCAD X Version 14.6.14 (7483)

**Area Scan (41x61x1):** Interpolated grid: dx=1.500 mm, dy=1.500 mm

Maximum value of SAR (interpolated) = 0.907 W/kg

**Zoom Scan (5x5x7)/Cube 0:** Measurement grid: dx=8mm, dy=8mm, dz=5mm

Reference Value = 24.73 V/m; Power Drift = 0.03 dB

Peak SAR (extrapolated) = 1.19 W/kg

**SAR(1 g) = 0.662 W/kg; SAR(10 g) = 0.338 W/kg**

Maximum value of SAR (measured) = 0.819 W/kg

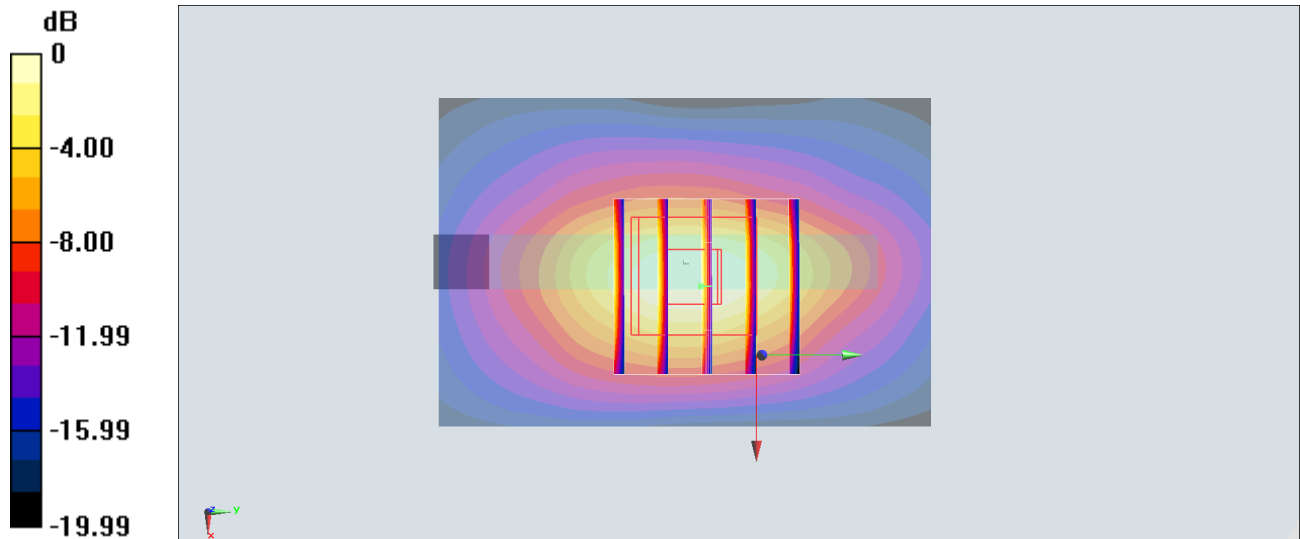

0 dB = 0.907 W/kg = -0.42 dBW/kg

**#18\_LTE Band 5\_10M\_QPSK\_1\_0\_Front\_10mm\_Ch20525**

Communication System: LTE; Frequency: 836.5 MHz; Duty Cycle: 1:1

Medium: HSL\_835\_200512 Medium parameters used :  $f = 836.5$  MHz;  $\sigma = 0.897$  S/m;  $\epsilon_r = 40.976$ ;  $\rho = 1000$  kg/m<sup>3</sup>

Ambient Temperature : 23.6 °C ; Liquid Temperature : 22.6 °C

DASY5 Configuration:

- Probe: ES3DV3 - SN3124; ConvF(6.28, 6.28, 6.28) @ 836.5 MHz; Calibrated: 2019/12/18
- Sensor-Surface: 3mm (Mechanical Surface Detection)
- Electronics: DAE4 Sn316; Calibrated: 2019/12/20
- Phantom: SAM\_Right; Type: QD000P40CD; Serial: TP:1815
- Measurement SW: DASY52, Version 52.10 (4); SEMCAD X Version 14.6.14 (7483)

**Area Scan (61x121x1):** Interpolated grid: dx=1.500 mm, dy=1.500 mm

Maximum value of SAR (interpolated) = 0.163 W/kg

**Zoom Scan (5x5x7)/Cube 0:** Measurement grid: dx=8mm, dy=8mm, dz=5mm

Reference Value = 13.57 V/m; Power Drift = 0.02 dB

Peak SAR (extrapolated) = 0.228 W/kg

**SAR(1 g) = 0.131 W/kg; SAR(10 g) = 0.078 W/kg**

Maximum value of SAR (measured) = 0.156 W/kg

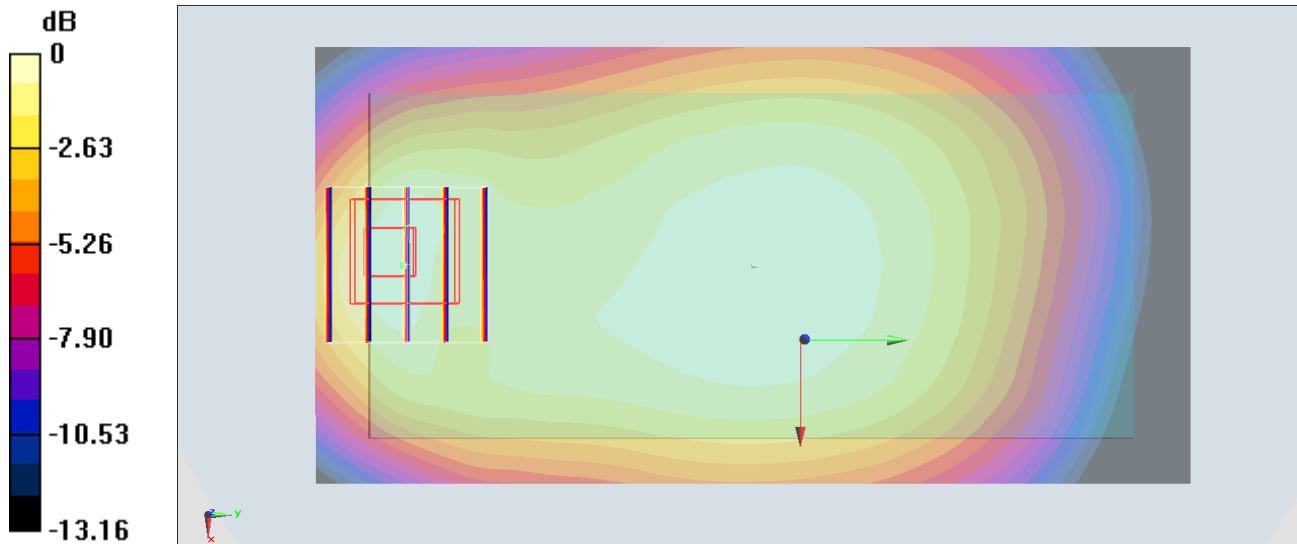

0 dB = 0.163 W/kg = -7.88 dBW/kg

## #19\_WLAN2.4GHz\_802.11b 1Mbps\_Back\_10mm\_Ch11

Communication System: 802.11b ; Frequency: 2462 MHz; Duty Cycle: 1:1.024

Medium: HSL\_2450\_200522 Medium parameters used:  $f = 2462$  MHz;  $\sigma = 1.817$  S/m;  $\epsilon_r = 37.869$ ;  $\rho = 1000$  kg/m<sup>3</sup>

Ambient Temperature : 23.2 °C ; Liquid Temperature : 22.2 °C

DASY5 Configuration:

- Probe: ES3DV3 - SN3124; ConvF(4.64, 4.64, 4.64) @ 2462 MHz; Calibrated: 2019/12/18
- Sensor-Surface: 3mm (Mechanical Surface Detection)
- Electronics: DAE4 Sn316; Calibrated: 2019/12/20
- Phantom: SAM\_Right; Type: SAM; Serial: TP-1303
- Measurement SW: DASY52, Version 52.10 (4); SEMCAD X Version 14.6.14 (7483)

**Area Scan (71x161x1):** Interpolated grid: dx=1.200 mm, dy=1.200 mm

Maximum value of SAR (interpolated) = 0.236 W/kg

**Zoom Scan (7x7x7)/Cube 0:** Measurement grid: dx=5mm, dy=5mm, dz=5mm

Reference Value = 7.704 V/m; Power Drift = -0.01 dB

Peak SAR (extrapolated) = 0.353 W/kg

**SAR(1 g) = 0.183 W/kg; SAR(10 g) = 0.100 W/kg**

Maximum value of SAR (measured) = 0.227 W/kg

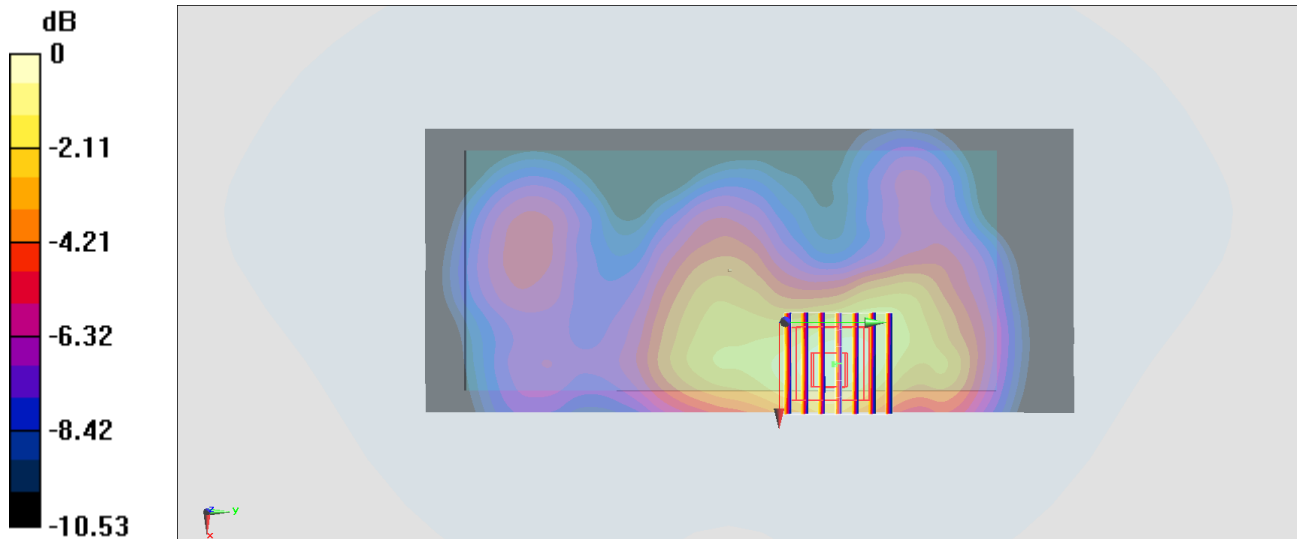

0 dB = 0.236 W/kg = -6.27 dBW/kg

## #20\_Bluetooth\_1Mbps\_Back\_10mm\_Ch39

Communication System: Bluetooth ; Frequency: 2441 MHz; Duty Cycle: 1:1.304

Medium: HSL\_2450\_200527 Medium parameters used :  $f = 2441$  MHz;  $\sigma = 1.853$  S/m;  $\epsilon_r = 39.281$ ;  $\rho = 1000$  kg/m<sup>3</sup>

Ambient Temperature : 23.4 °C ; Liquid Temperature : 22.4 °C

DASY5 Configuration:

- Probe: EX3DV4 - SN7306; ConvF(7.48, 7.48, 7.48) @ 2441 MHz; Calibrated: 2019/7/22
- Sensor-Surface: 1.4mm (Mechanical Surface Detection)
- Electronics: DAE4 Sn679; Calibrated: 2020/5/6
- Phantom: SAM\_Left; Type: QD000P40CD; Serial: TP:1815
- Measurement SW: DASY52, Version 52.10 (4); SEMCAD X Version 14.6.14 (7483)

**Area Scan (81x161x1):** Interpolated grid: dx=1.200 mm, dy=1.200 mm

Maximum value of SAR (interpolated) = 0.0500 W/kg

**Zoom Scan (7x7x7)/Cube 0:** Measurement grid: dx=5mm, dy=5mm, dz=5mm

Reference Value = 0.5560 V/m; Power Drift = 0.12 dB

Peak SAR (extrapolated) = 0.0680 W/kg

**SAR(1 g) = 0.028 W/kg; SAR(10 g) = 0.015 W/kg**

Maximum value of SAR (measured) = 0.0463 W/kg

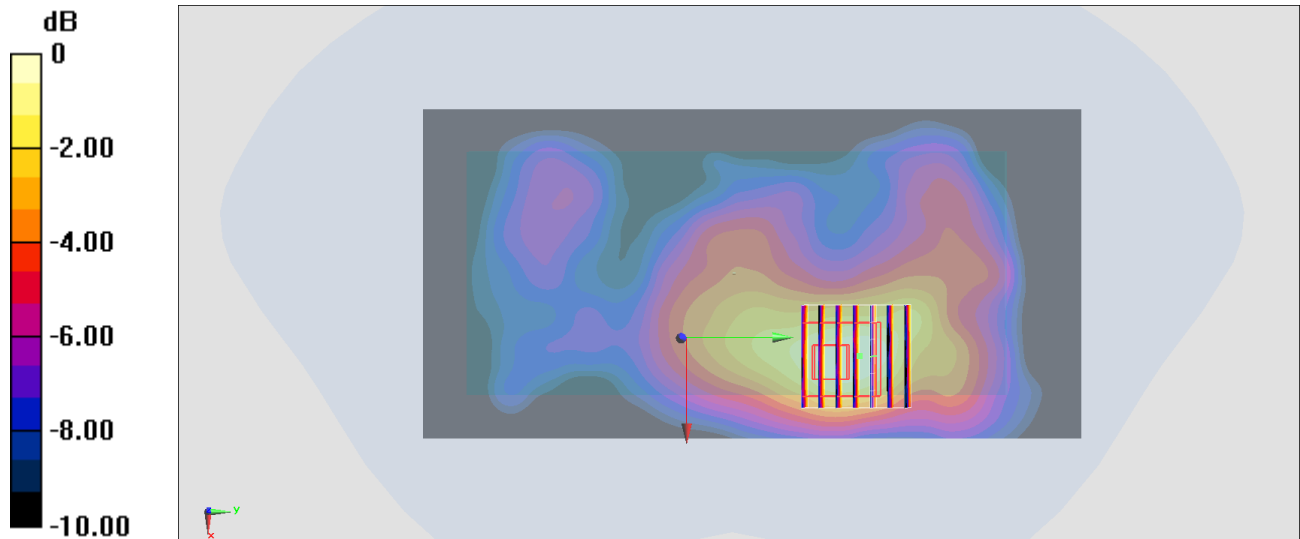

0 dB = 0.0500 W/kg = -13.01 dBW/kg

**#21\_GSM1900\_GPRS (4 Tx slots)\_Front\_15mm\_Ch661**

Communication System: PCS 1900; Frequency: 1880 MHz; Duty Cycle: 1:2.08

Medium: HSL\_1900\_200521 Medium parameters used:  $f = 1880$  MHz;  $\sigma = 1.398$  S/m;  $\epsilon_r = 38.74$ ;  $\rho = 1000$  kg/m<sup>3</sup>

Ambient Temperature : 23.6 °C ; Liquid Temperature : 22.6 °C

DASY5 Configuration:

- Probe: ES3DV3 - SN3124; ConvF(5.31, 5.31, 5.31) @ 1880 MHz; Calibrated: 2019/12/18
- Sensor-Surface: 3mm (Mechanical Surface Detection)
- Electronics: DAE4 Sn316; Calibrated: 2019/12/20
- Phantom: SAM\_Right; Type: QD000P40CD; Serial: TP:1815
- Measurement SW: DASY52, Version 52.10 (4); SEMCAD X Version 14.6.14 (7483)

**Area Scan (61x131x1):** Interpolated grid: dx=1.500 mm, dy=1.500 mm

Maximum value of SAR (interpolated) = 0.360 W/kg

**Zoom Scan (5x5x7)/Cube 0:** Measurement grid: dx=8mm, dy=8mm, dz=5mm

Reference Value = 5.132 V/m; Power Drift = 0.13 dB

Peak SAR (extrapolated) = 0.527 W/kg

**SAR(1 g) = 0.295 W/kg; SAR(10 g) = 0.164 W/kg**

Maximum value of SAR (measured) = 0.367 W/kg

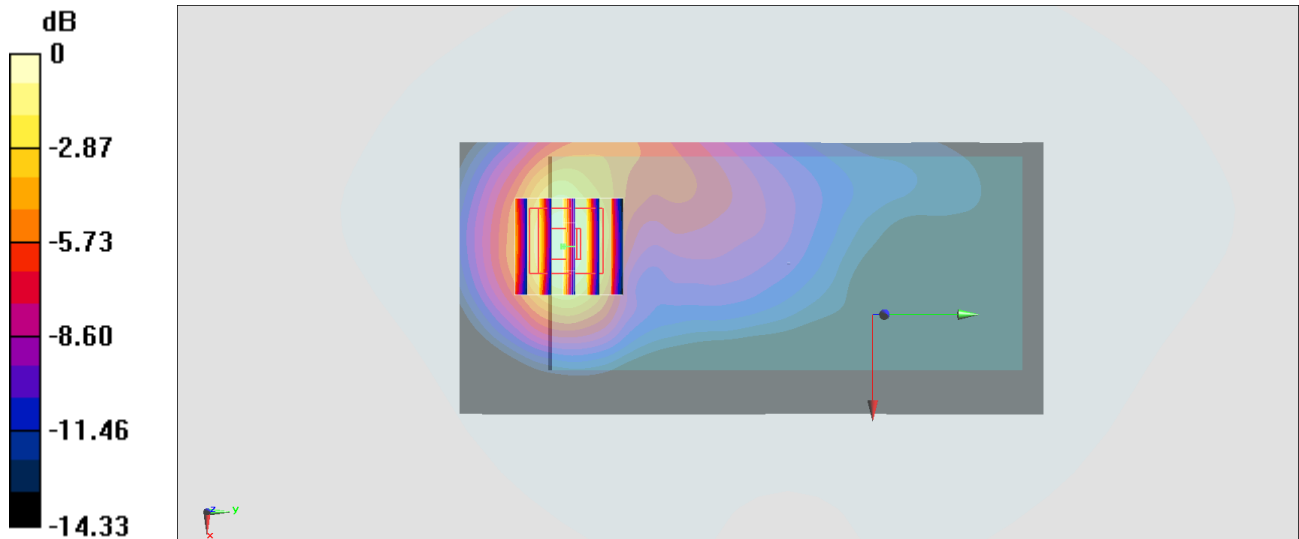

0 dB = 0.360 W/kg = -4.44 dBW/kg

**#22\_WCDMA II\_RMC 12.2Kbps\_Front\_15mm\_Ch9538**

Communication System: WCDMA; Frequency: 1907.6 MHz; Duty Cycle: 1:1

Medium: HSL\_1900\_200521 Medium parameters used:  $f = 1908$  MHz;  $\sigma = 1.427$  S/m;  $\epsilon_r = 38.608$ ;  $\rho = 1000$  kg/m<sup>3</sup>

Ambient Temperature : 23.6 °C; Liquid Temperature : 22.6 °C

DASY5 Configuration:

- Probe: ES3DV3 - SN3124; ConvF(5.31, 5.31, 5.31) @ 1907.6 MHz; Calibrated: 2019/12/18
- Sensor-Surface: 3mm (Mechanical Surface Detection)
- Electronics: DAE4 Sn316; Calibrated: 2019/12/20
- Phantom: SAM\_Right; Type: QD000P40CD; Serial: TP:1815
- Measurement SW: DASY52, Version 52.10 (4); SEMCAD X Version 14.6.14 (7483)

**Area Scan (61x131x1):** Interpolated grid: dx=1.500 mm, dy=1.500 mm

Maximum value of SAR (interpolated) = 0.686 W/kg

**Zoom Scan (5x5x7)/Cube 0:** Measurement grid: dx=8mm, dy=8mm, dz=5mm

Reference Value = 6.923 V/m; Power Drift = -0.04 dB

Peak SAR (extrapolated) = 0.943 W/kg

**SAR(1 g) = 0.551 W/kg; SAR(10 g) = 0.310 W/kg**

Maximum value of SAR (measured) = 0.673 W/kg

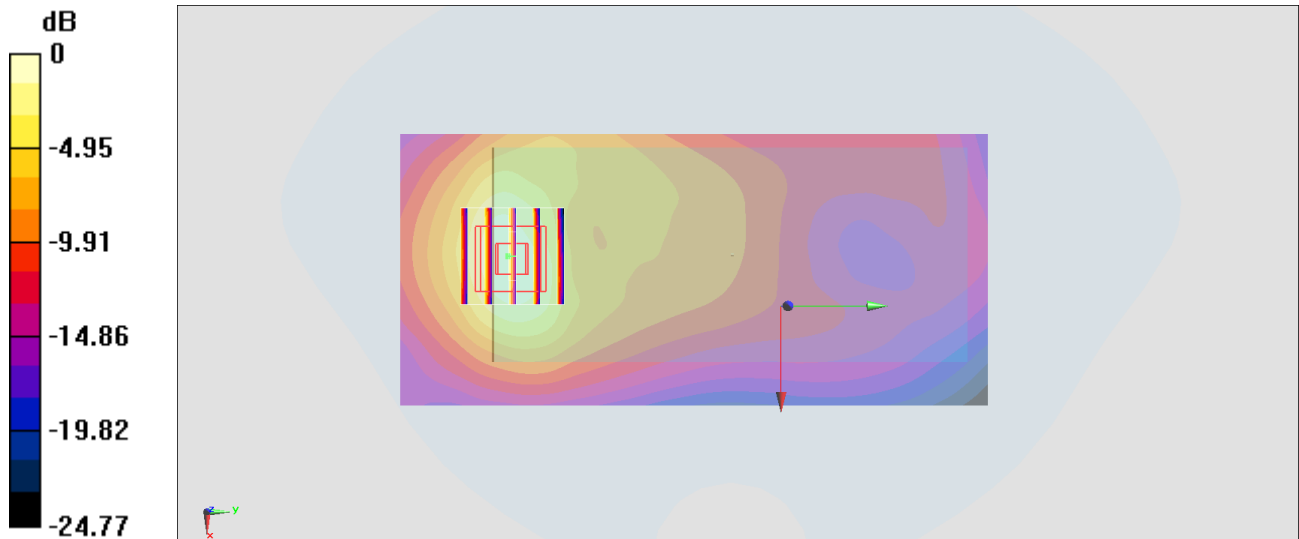

0 dB = 0.686 W/kg = -1.64 dBW/kg

## #23\_WCDMA IV\_RMC 12.2Kbps\_Front\_15mm\_Ch1413

Communication System: WCDMA; Frequency: 1732.6 MHz; Duty Cycle: 1:1

Medium: HSL\_1750\_200521 Medium parameters used:  $f = 1733$  MHz;  $\sigma = 1.363$  S/m;  $\epsilon_r = 41.328$ ;  $\rho = 1000$  kg/m<sup>3</sup>

Ambient Temperature : 23.6 °C ; Liquid Temperature : 22.6 °C

DASY5 Configuration:

- Probe: ES3DV3 - SN3124; ConvF(5.53, 5.53, 5.53) @ 1732.6 MHz; Calibrated: 2019/12/18
- Sensor-Surface: 3mm (Mechanical Surface Detection)
- Electronics: DAE4 Sn316; Calibrated: 2019/12/20
- Phantom: SAM\_Right; Type: QD000P40CD; Serial: TP:1815
- Measurement SW: DASY52, Version 52.10 (4); SEMCAD X Version 14.6.14 (7483)

**Area Scan (61x131x1):** Interpolated grid: dx=1.500 mm, dy=1.500 mm

Maximum value of SAR (interpolated) = 0.555 W/kg

**Zoom Scan (5x5x7)/Cube 0:** Measurement grid: dx=8mm, dy=8mm, dz=5mm

Reference Value = 8.206 V/m; Power Drift = -0.07 dB

Peak SAR (extrapolated) = 0.773 W/kg

**SAR(1 g) = 0.455 W/kg; SAR(10 g) = 0.253 W/kg**

Maximum value of SAR (measured) = 0.563 W/kg

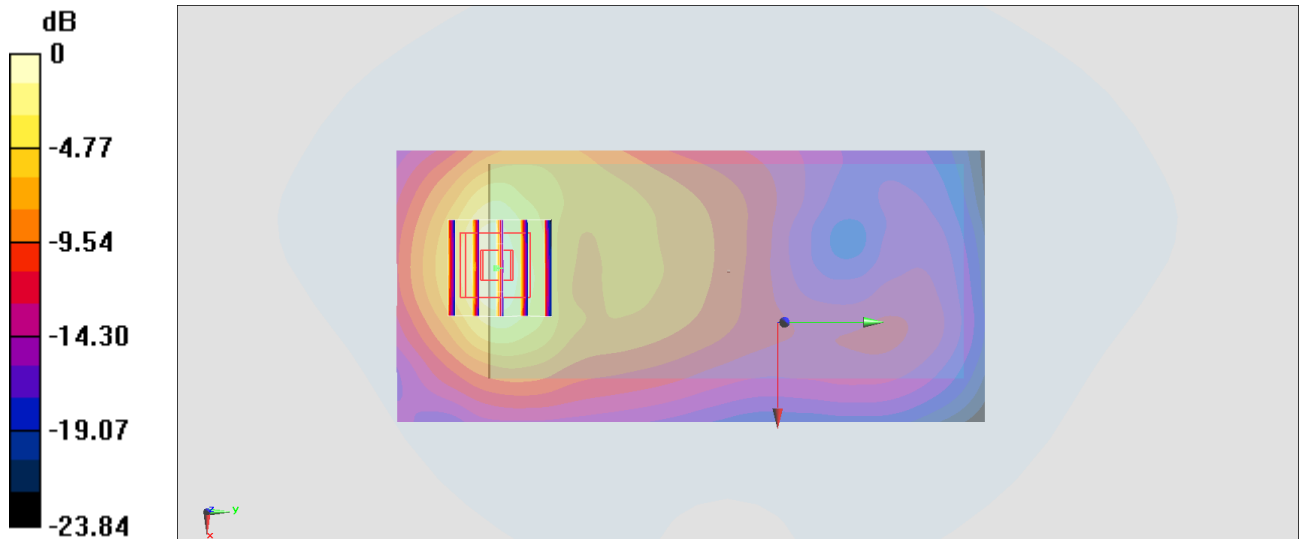

0 dB = 0.555 W/kg = -2.56 dBW/kg

**#24\_WCDMA V\_RMC 12.2Kbps\_Front\_15mm\_Ch4233**

Communication System: WCDMA; Frequency: 846.6 MHz; Duty Cycle: 1:1

Medium: HSL\_835\_200522 Medium parameters used:  $f = 847$  MHz;  $\sigma = 0.901$  S/m;  $\epsilon_r = 42.057$ ;  $\rho = 1000$  kg/m<sup>3</sup>

Ambient Temperature : 23.6 °C ; Liquid Temperature : 22.6 °C

DASY5 Configuration:

- Probe: ES3DV3 - SN3124; ConvF(6.28, 6.28, 6.28) @ 846.6 MHz; Calibrated: 2019/12/18
- Sensor-Surface: 3mm (Mechanical Surface Detection)
- Electronics: DAE4 Sn316; Calibrated: 2019/12/20
- Phantom: SAM\_Right; Type: QD000P40CD; Serial: TP:1815
- Measurement SW: DASY52, Version 52.10 (4); SEMCAD X Version 14.6.14 (7483)

**Area Scan (61x121x1):** Interpolated grid: dx=1.500 mm, dy=1.500 mm

Maximum value of SAR (interpolated) = 0.163 W/kg

**Zoom Scan (5x5x7)/Cube 0:** Measurement grid: dx=8mm, dy=8mm, dz=5mm

Reference Value = 13.92 V/m; Power Drift = -0.05 dB

Peak SAR (extrapolated) = 0.195 W/kg

**SAR(1 g) = 0.149 W/kg; SAR(10 g) = 0.112 W/kg**

Maximum value of SAR (measured) = 0.165 W/kg

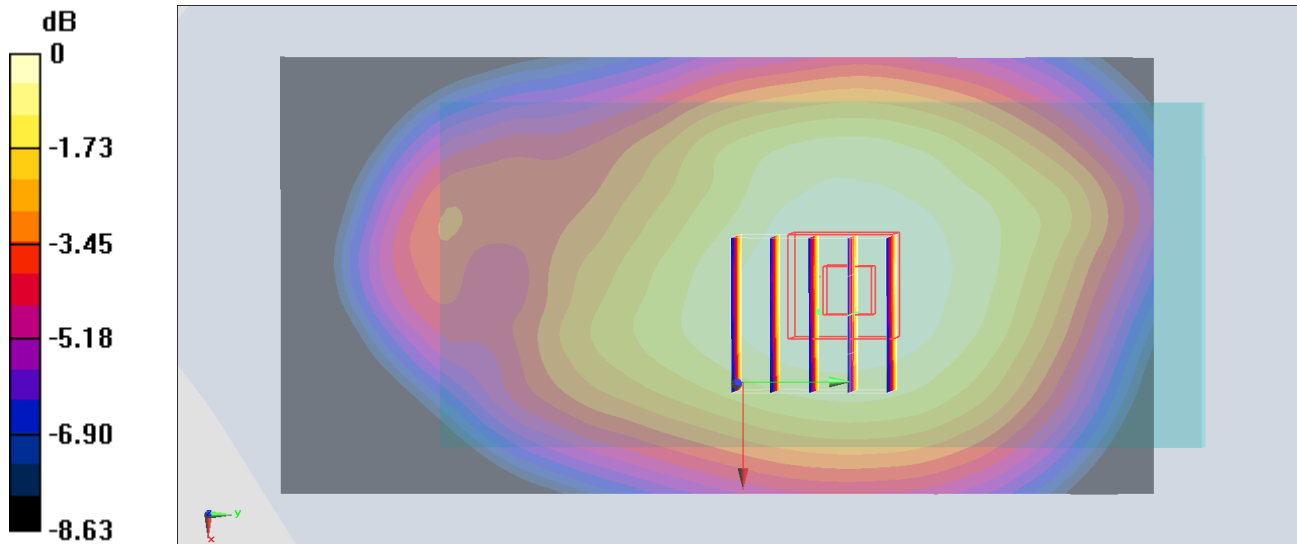

0 dB = 0.165 W/kg = -7.83 dBW/kg



**#25\_LTE Band 2\_20M\_QPSK\_1\_0\_Front\_15mm\_Ch19100**

Communication System: LTE; Frequency: 1900 MHz; Duty Cycle: 1:1

Medium: HSL\_1900\_200521 Medium parameters used:  $f = 1900$  MHz;  $\sigma = 1.42$  S/m;  $\epsilon_r = 38.642$ ;  $\rho = 1000$  kg/m<sup>3</sup>

Ambient Temperature : 23.6 °C ; Liquid Temperature : 22.6 °C

DASY5 Configuration:

- Probe: ES3DV3 - SN3124; ConvF(5.31, 5.31, 5.31) @ 1900 MHz; Calibrated: 2019/12/18
- Sensor-Surface: 3mm (Mechanical Surface Detection)
- Electronics: DAE4 Sn316; Calibrated: 2019/12/20
- Phantom: SAM\_Right; Type: QD000P40CD; Serial: TP:1815
- Measurement SW: DASY52, Version 52.10 (4); SEMCAD X Version 14.6.14 (7483)

**Area Scan (61x131x1):** Interpolated grid: dx=1.500 mm, dy=1.500 mm

Maximum value of SAR (interpolated) = 0.538 W/kg

**Zoom Scan (5x5x7)/Cube 0:** Measurement grid: dx=8mm, dy=8mm, dz=5mm

Reference Value = 6.438 V/m; Power Drift = 0.07 dB

Peak SAR (extrapolated) = 0.757 W/kg

**SAR(1 g) = 0.439 W/kg; SAR(10 g) = 0.243 W/kg**

Maximum value of SAR (measured) = 0.543 W/kg

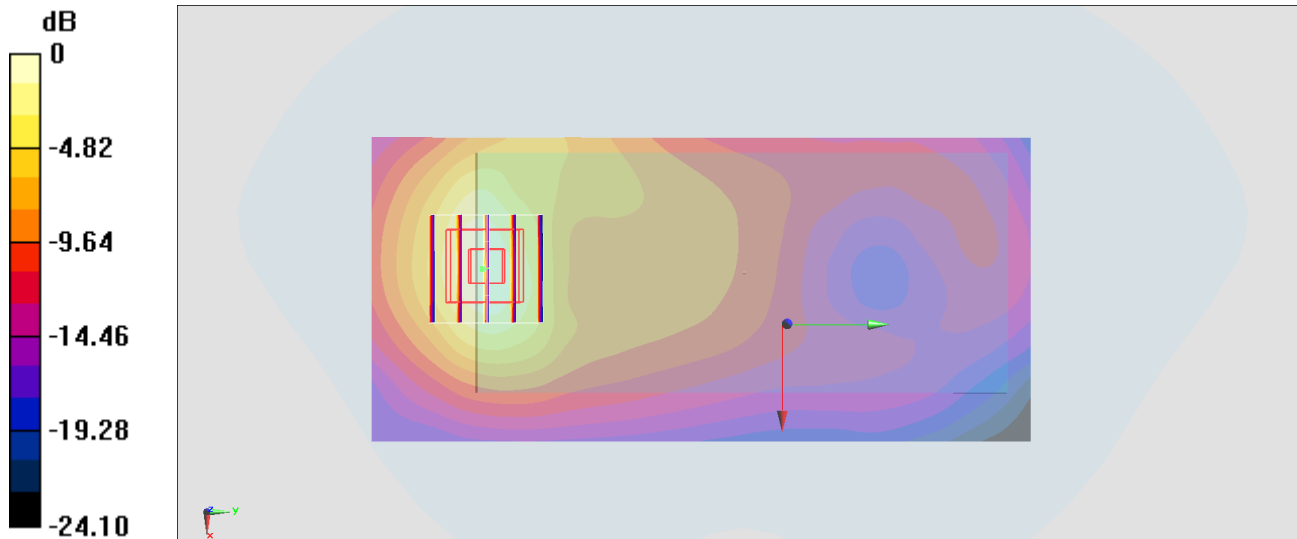

0 dB = 0.538 W/kg = -2.69 dBW/kg

## #26\_LTE Band 4\_20M\_QPSK\_1\_0\_Front\_15mm\_Ch20175

Communication System: LTE; Frequency: 1732.5 MHz; Duty Cycle: 1:1

Medium: HSL\_1750\_200521 Medium parameters used:  $f = 1733$  MHz;  $\sigma = 1.363$  S/m;  $\epsilon_r = 41.328$ ;  $\rho = 1000$  kg/m<sup>3</sup>

Ambient Temperature : 23.6 °C ; Liquid Temperature : 22.6 °C

DASY5 Configuration:

- Probe: ES3DV3 - SN3124; ConvF(5.53, 5.53, 5.53) @ 1732.5 MHz; Calibrated: 2019/12/18
- Sensor-Surface: 3mm (Mechanical Surface Detection)
- Electronics: DAE4 Sn316; Calibrated: 2019/12/20
- Phantom: SAM\_Right; Type: QD000P40CD; Serial: TP:1815
- Measurement SW: DASY52, Version 52.10 (4); SEMCAD X Version 14.6.14 (7483)

**Area Scan (61x131x1):** Interpolated grid: dx=1.500 mm, dy=1.500 mm

Maximum value of SAR (interpolated) = 0.537 W/kg

**Zoom Scan (5x5x7)/Cube 0:** Measurement grid: dx=8mm, dy=8mm, dz=5mm

Reference Value = 6.049 V/m; Power Drift = -0.00 dB

Peak SAR (extrapolated) = 0.750 W/kg

**SAR(1 g) = 0.445 W/kg; SAR(10 g) = 0.248 W/kg**

Maximum value of SAR (measured) = 0.549 W/kg

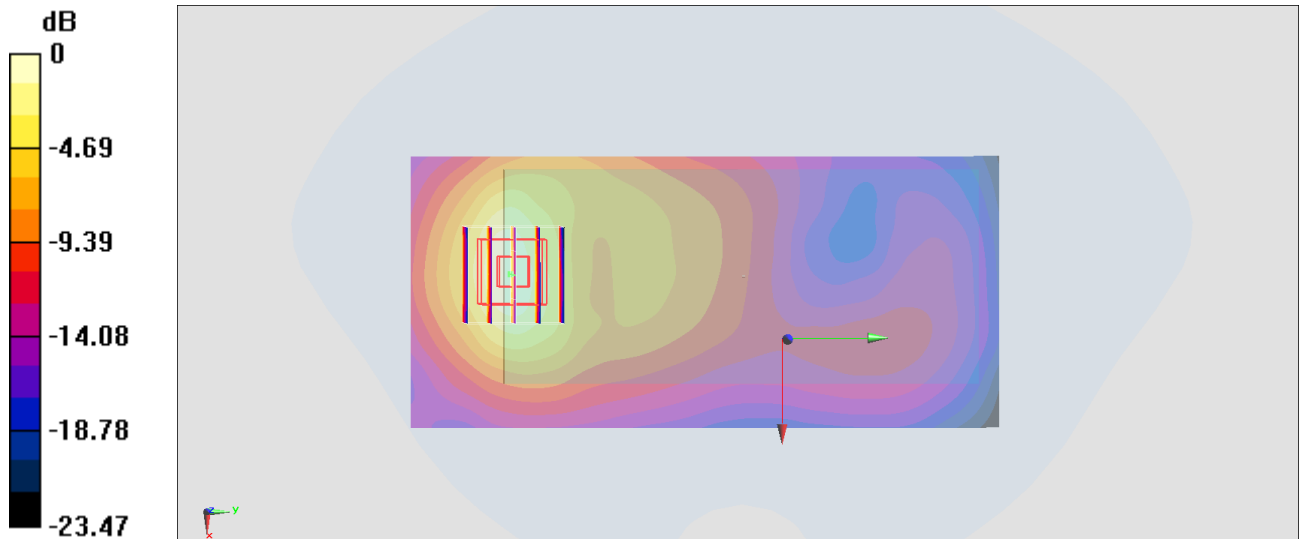

0 dB = 0.537 W/kg = -2.70 dBW/kg

**#27\_LTE Band 5\_10M\_QPSK\_1\_0\_Front\_15mm\_Ch20525**

Communication System: LTE; Frequency: 836.5 MHz; Duty Cycle: 1:1

Medium: HSL\_835\_200522 Medium parameters used :  $f = 836.5$  MHz;  $\sigma = 0.891$  S/m;  $\epsilon_r = 42.197$ ;  $\rho = 1000$  kg/m<sup>3</sup>

Ambient Temperature : 23.6 °C ; Liquid Temperature : 22.6 °C

DASY5 Configuration:

- Probe: ES3DV3 - SN3124; ConvF(6.28, 6.28, 6.28) @ 836.5 MHz; Calibrated: 2019/12/18
- Sensor-Surface: 3mm (Mechanical Surface Detection)
- Electronics: DAE4 Sn316; Calibrated: 2019/12/20
- Phantom: SAM\_Right; Type: QD000P40CD; Serial: TP:1815
- Measurement SW: DASY52, Version 52.10 (4); SEMCAD X Version 14.6.14 (7483)

**Area Scan (61x121x1):** Interpolated grid: dx=1.500 mm, dy=1.500 mm

Maximum value of SAR (interpolated) = 0.139 W/kg

**Zoom Scan (5x5x7)/Cube 0:** Measurement grid: dx=8mm, dy=8mm, dz=5mm

Reference Value = 12.47 V/m; Power Drift = 0.02 dB

Peak SAR (extrapolated) = 0.161 W/kg

**SAR(1 g) = 0.120 W/kg; SAR(10 g) = 0.090 W/kg**

Maximum value of SAR (measured) = 0.135 W/kg

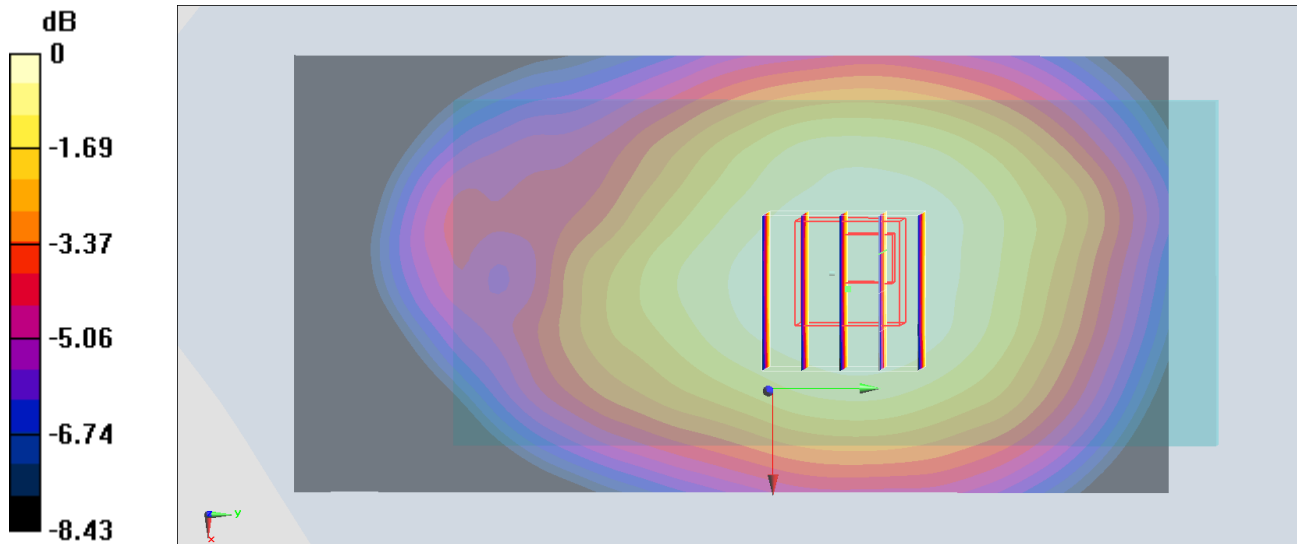

**#28\_WLAN2.4GHz\_802.11b 1Mbps\_Back\_15mm\_Ch11**

Communication System: 802.11b ; Frequency: 2462 MHz;Duty Cycle: 1:1.024

Medium: HSL\_2450\_200522 Medium parameters used:  $f = 2462$  MHz;  $\sigma = 1.817$  S/m;  $\epsilon_r = 37.869$ ;  $\rho = 1000$  kg/m<sup>3</sup>

Ambient Temperature : 23.2 °C ; Liquid Temperature : 22.2 °C

DASY5 Configuration:

- Probe: ES3DV3 - SN3124; ConvF(4.64, 4.64, 4.64) @ 2462 MHz; Calibrated: 2019/12/18
- Sensor-Surface: 3mm (Mechanical Surface Detection)
- Electronics: DAE4 Sn316; Calibrated: 2019/12/20
- Phantom: SAM\_Right; Type: SAM; Serial: TP-1303
- Measurement SW: DASY52, Version 52.10 (4);SEMCAD X Version 14.6.14 (7483)

**Area Scan (71x161x1):** Interpolated grid: dx=1.200 mm, dy=1.200 mm

Maximum value of SAR (interpolated) = 0.110 W/kg

**Zoom Scan (7x7x7)/Cube 0:** Measurement grid: dx=5mm, dy=5mm, dz=5mm

Reference Value = 6.266 V/m; Power Drift = 0.05 dB

Peak SAR (extrapolated) = 0.162 W/kg

**SAR(1 g) = 0.088 W/kg; SAR(10 g) = 0.050 W/kg**

Maximum value of SAR (measured) = 0.108 W/kg

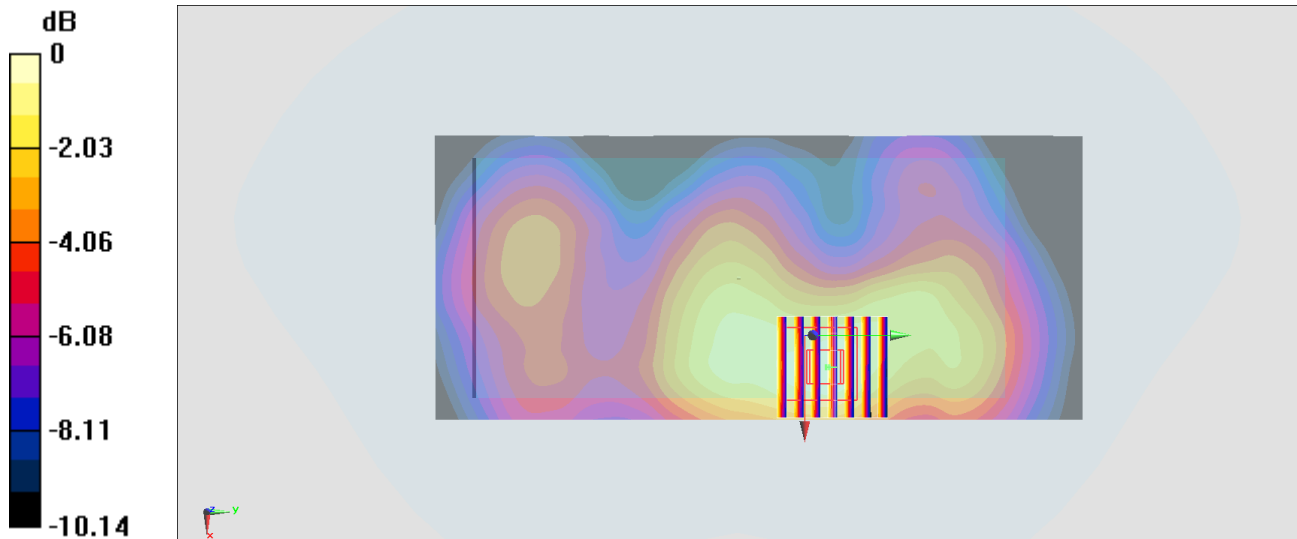

0 dB = 0.110 W/kg = -9.59 dBW/kg

**#29\_WLAN5GHz\_802.11ac-VHT80 MCS0\_Back\_15mm\_Ch58**

Communication System: 802.11ac ; Frequency: 5290 MHz;Duty Cycle: 1:1.159

Medium: HSL\_5G\_200523 Medium parameters used :  $f = 5290$  MHz;  $\sigma = 4.716$  S/m;  $\epsilon_r = 36.561$ ;  $\rho = 1000$  kg/m<sup>3</sup>

Ambient Temperature : 23.3 °C ; Liquid Temperature : 22.3 °C

DASY5 Configuration:

- Probe: EX3DV4 - SN3642;ConvF(4.43, 4.43, 4.43) @ 5290 MHz;Calibrated: 2020/4/29
- Sensor-Surface: 1.4mm (Mechanical Surface Detection)
- Electronics: DAE4 Sn913; Calibrated: 2020/5/6
- Phantom: SAM\_Left; Type: QD000P40CD; Serial: TP:1801
- Measurement SW: DASY52, Version 52.10 (4);SEMCAD X Version 14.6.14 (7483)

**Area Scan (121x121x1):** Interpolated grid: dx=1.000 mm, dy=1.000 mm

Maximum value of SAR (interpolated) = 0.124 W/kg

**Zoom Scan (7x7x7)/Cube 0:** Measurement grid: dx=4mm, dy=4mm, dz=1.4mm

Reference Value = 0.4860 V/m; Power Drift = 0.14 dB

Peak SAR (extrapolated) = 0.254 W/kg

**SAR(1 g) = 0.035 W/kg; SAR(10 g) = 0.013 W/kg**

Maximum value of SAR (measured) = 0.0992 W/kg

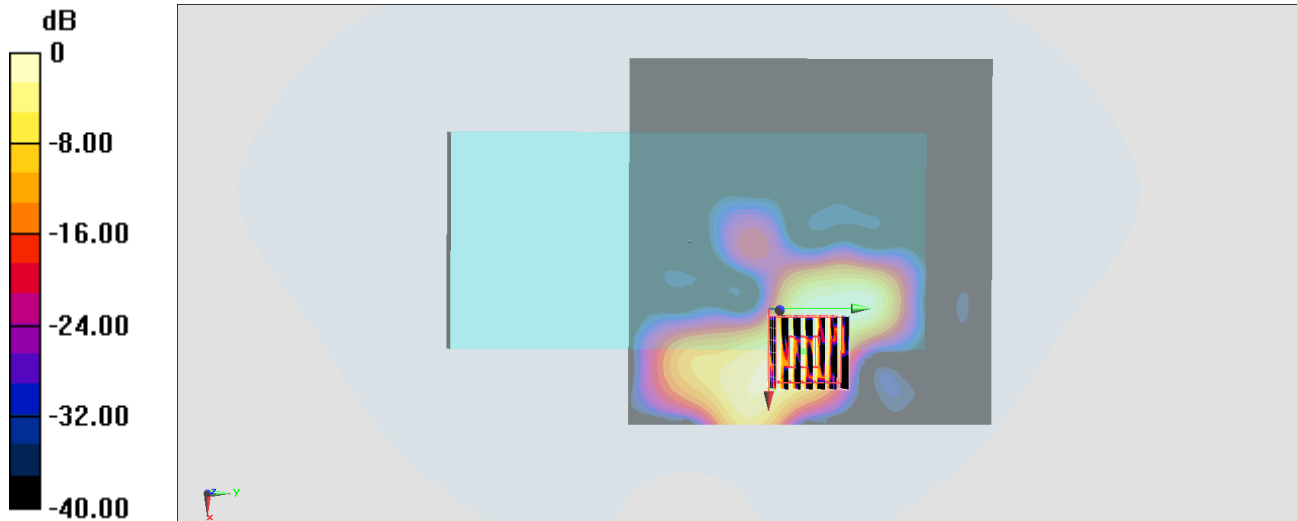

0 dB = 0.0992 W/kg = -10.03 dBW/kg

### #30\_WLAN5GHz\_802.11ac-VHT80 MCS0\_Back\_15mm\_Ch122

Communication System:802.11ac ; Frequency: 5610 MHz;Duty Cycle: 1:1.159

Medium: HSL\_5G\_200523 Medium parameters used:  $f = 5610$  MHz;  $\sigma = 5.069$  S/m;  $\epsilon_r = 36.425$ ;  $\rho = 1000$  kg/m<sup>3</sup>

Ambient Temperature : 23.3 °C ; Liquid Temperature : 22.3 °C

DASY5 Configuration:

- Probe: EX3DV4 - SN3642;ConvF(4.19, 4.19, 4.19) @ 5610 MHz;Calibrated: 2020/4/29
- Sensor-Surface: 1.4mm (Mechanical Surface Detection)
- Electronics: DAE4 Sn913; Calibrated: 2020/5/6
- Phantom: SAM\_Left; Type: QD000P40CD; Serial: TP:1801
- Measurement SW: DASY52, Version 52.10 (4);SEMCAD X Version 14.6.14 (7483)

**Area Scan (121x121x1):** Interpolated grid: dx=1.000 mm, dy=1.000 mm

Maximum value of SAR (interpolated) = 0.351 W/kg

**Zoom Scan (7x7x7)/Cube 0:** Measurement grid: dx=4mm, dy=4mm, dz=1.4mm

Reference Value = 0 V/m; Power Drift = 0.00 dB

Peak SAR (extrapolated) = 0.384 W/kg

**SAR(1 g) = 0.090 W/kg; SAR(10 g) = 0.031 W/kg**

Maximum value of SAR (measured) = 0.243 W/kg

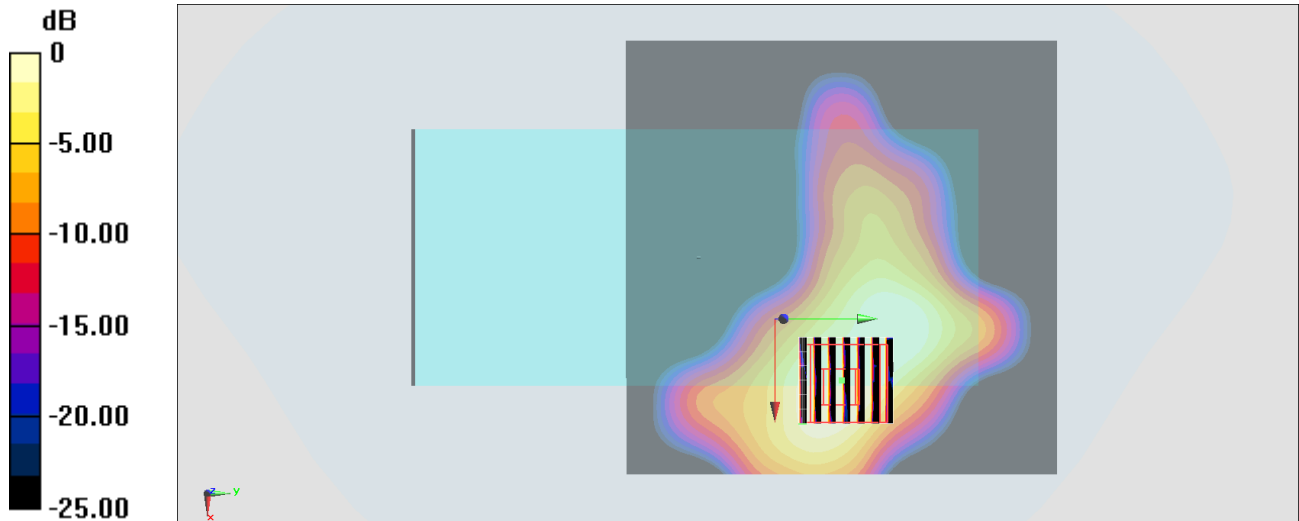

0 dB = 0.243 W/kg = -6.14 dBW/kg

### #31\_Bluetooth\_1Mbps\_Back\_15mm\_Ch39

Communication System: Bluetooth ; Frequency: 2441 MHz; Duty Cycle: 1:1.304

Medium: HSL\_2450\_200527 Medium parameters used :  $f = 2441$  MHz;  $\sigma = 1.853$  S/m;  $\epsilon_r = 39.281$ ;  $\rho = 1000$  kg/m<sup>3</sup>

Ambient Temperature : 23.4 °C ; Liquid Temperature : 22.4 °C

DASY5 Configuration:

- Probe: EX3DV4 - SN7306; ConvF(7.48, 7.48, 7.48) @ 2441 MHz; Calibrated: 2019/7/22
- Sensor-Surface: 1.4mm (Mechanical Surface Detection)
- Electronics: DAE4 Sn679; Calibrated: 2020/5/6
- Phantom: SAM\_Left; Type: QD000P40CD; Serial: TP:1815
- Measurement SW: DASY52, Version 52.10 (4); SEMCAD X Version 14.6.14 (7483)

**Area Scan (81x161x1):** Interpolated grid: dx=1.200 mm, dy=1.200 mm

Maximum value of SAR (interpolated) = 0.0179 W/kg

**Zoom Scan (7x7x7)/Cube 0:** Measurement grid: dx=5mm, dy=5mm, dz=5mm

Reference Value = 0.6590 V/m; Power Drift = 0.19 dB

Peak SAR (extrapolated) = 0.0210 W/kg

**SAR(1 g) = 0.011 W/kg; SAR(10 g) = 0.00646 W/kg**

Maximum value of SAR (measured) = 0.0173 W/kg

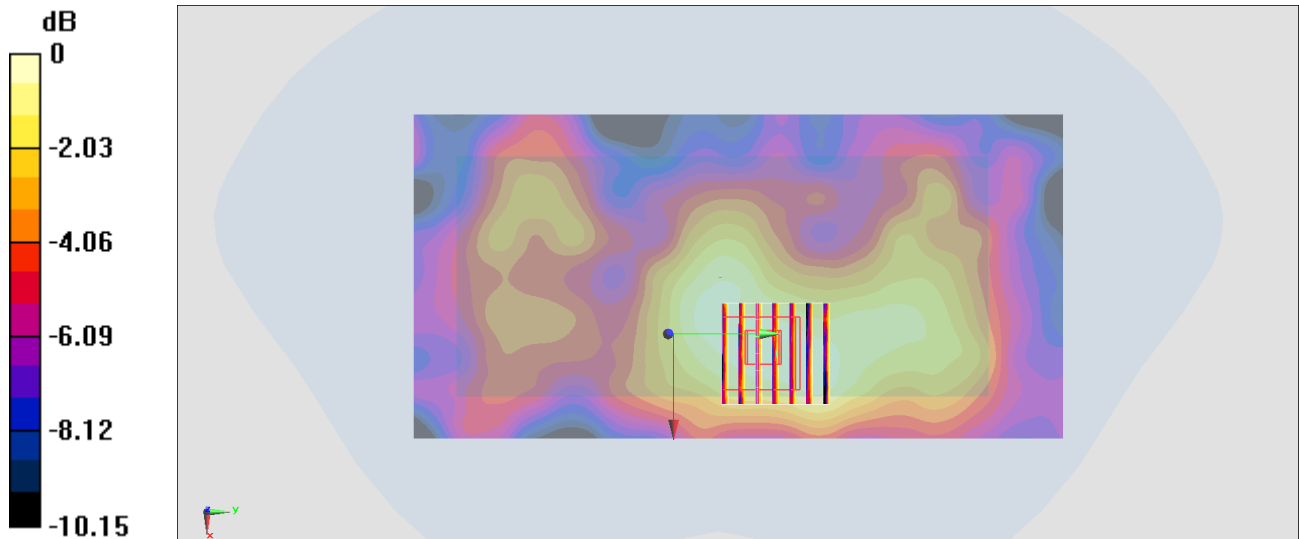

0 dB = 0.0179 W/kg = -17.47 dBW/kg

**#32\_WCDMA II\_RMC 12.2Kbps\_Bottom Side\_0mm\_Ch9262**

Communication System: WCDMA ; Frequency: 1852.4 MHz;Duty Cycle: 1:1  
Medium: HSL\_1900\_200527 Medium parameters used :  $f = 1852.4$  MHz;  $\sigma = 1.374$  S/m;  $\epsilon_r = 39.363$ ;  $\rho = 1000$  kg/m<sup>3</sup>  
Ambient Temperature : 23.4 °C ; Liquid Temperature : 22.4 °C

**DASY5 Configuration:**

- Probe: EX3DV4 - SN7306; ConvF(8.15, 8.15, 8.15) @ 1852.4 MHz; Calibrated: 2019/7/22
- Sensor-Surface: 1.4mm (Mechanical Surface Detection)
- Electronics: DAE4 Sn679; Calibrated: 2020/5/6
- Phantom: SAM\_Left; Type: QD000P40CD; Serial: TP:1815
- Measurement SW: DASY52, Version 52.10 (4);SEMCAD X Version 14.6.14 (7483)

**Area Scan (41x61x1):** Interpolated grid: dx=1.500 mm, dy=1.500 mm  
Maximum value of SAR (interpolated) = 15.3 W/kg

**Zoom Scan (5x5x7)/Cube 0:** Measurement grid: dx=8mm, dy=8mm, dz=5mm  
Reference Value = 2.536 V/m; Power Drift = -0.15 dB  
Peak SAR (extrapolated) = 18.3 W/kg  
**SAR(1 g) = 6.33 W/kg; SAR(10 g) = 2.74 W/kg**  
Maximum value of SAR (measured) = 14.2 W/kg

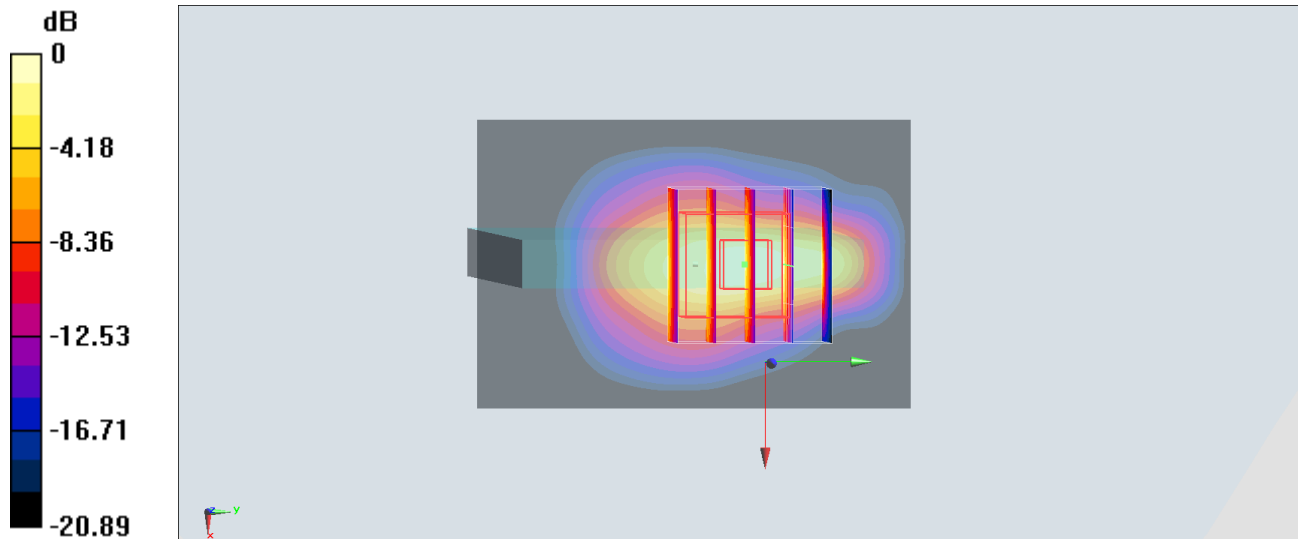

0 dB = 15.3 W/kg = 11.85 dBW/kg



**#33\_WCDMA IV\_RMC 12.2Kbps\_Bottom Side\_0mm\_Ch1312**

Communication System: WCDMA ; Frequency: 1712.4 MHz; Duty Cycle: 1:1  
Medium: HSL\_1750\_200527 Medium parameters used :  $f = 1712.4$  MHz;  $\sigma = 1.335$  S/m;  $\epsilon_r = 40.702$ ;  $\rho = 1000$  kg/m<sup>3</sup>  
Ambient Temperature : 23.4 °C ; Liquid Temperature : 22.4 °C

**DASY5 Configuration:**

- Probe: EX3DV4 - SN7306; ConvF(8.51, 8.51, 8.51) @ 1712.4 MHz; Calibrated: 2019/7/22
- Sensor-Surface: 1.4mm (Mechanical Surface Detection)
- Electronics: DAE4 Sn679; Calibrated: 2020/5/6
- Phantom: SAM\_Left; Type: QD000P40CD; Serial: TP:1815
- Measurement SW: DASY52, Version 52.10 (4); SEMCAD X Version 14.6.14 (7483)

**Area Scan (41x61x1):** Interpolated grid: dx=1.500 mm, dy=1.500 mm  
Maximum value of SAR (interpolated) = 15.0 W/kg

**Zoom Scan (5x5x7)/Cube 0:** Measurement grid: dx=8mm, dy=8mm, dz=5mm  
Reference Value = 2.492 V/m; Power Drift = -0.09 dB  
Peak SAR (extrapolated) = 18.0 W/kg  
**SAR(1 g) = 6.26 W/kg; SAR(10 g) = 2.69 W/kg**  
Maximum value of SAR (measured) = 13.9 W/kg

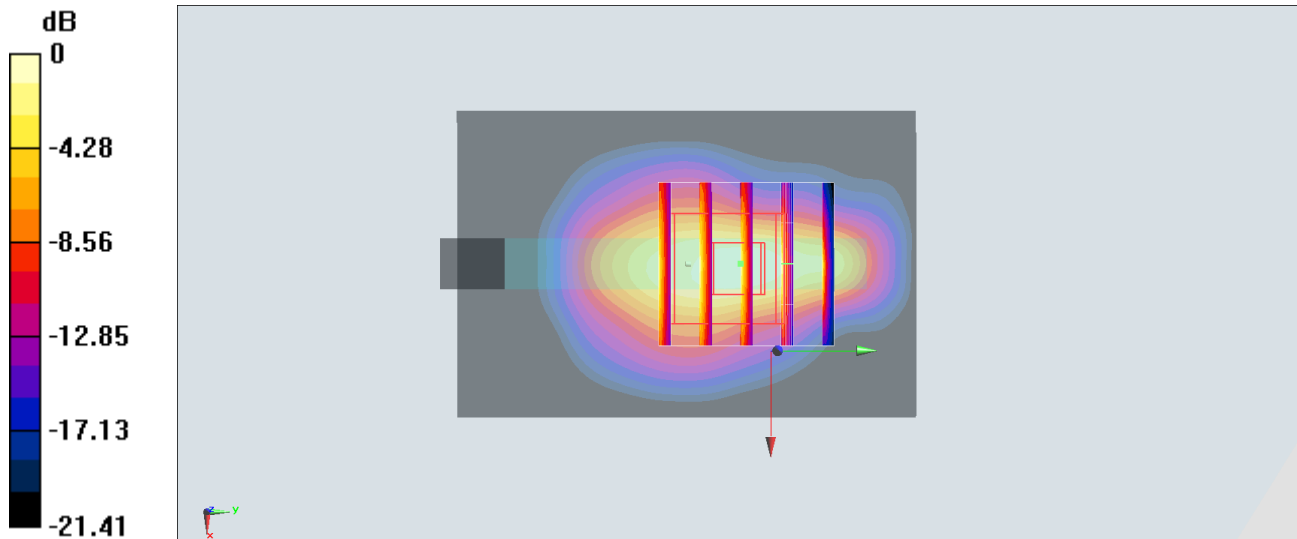

0 dB = 15.0 W/kg = 11.76 dBW/kg

**#34\_LTE Band 2\_20M\_QPSK\_1\_0\_Bottom Side\_0mm\_Ch18700**

Communication System: LTE ; Frequency: 1860 MHz;Duty Cycle: 1:1

Medium: HSL\_1900\_200527 Medium parameters used:  $f = 1860$  MHz;  $\sigma = 1.381$  S/m;  $\epsilon_r = 39.343$ ;  $\rho = 1000$  kg/m<sup>3</sup>

Ambient Temperature : 23.4 °C ; Liquid Temperature : 22.4 °C

DASY5 Configuration:

- Probe: EX3DV4 - SN7306; ConvF(8.15, 8.15, 8.15) @ 1860 MHz; Calibrated: 2019/7/22
- Sensor-Surface: 1.4mm (Mechanical Surface Detection)
- Electronics: DAE4 Sn679; Calibrated: 2020/5/6
- Phantom: SAM\_Left; Type: QD000P40CD; Serial: TP:1815
- Measurement SW: DASY52, Version 52.10 (4);SEMCAD X Version 14.6.14 (7483)

**Area Scan (41x61x1):** Interpolated grid: dx=1.500 mm, dy=1.500 mm

Maximum value of SAR (interpolated) = 12.2 W/kg

**Zoom Scan (5x5x7)/Cube 0:** Measurement grid: dx=8mm, dy=8mm, dz=5mm

Reference Value = 79.58 V/m; Power Drift = 0.09 dB

Peak SAR (extrapolated) = 15.5 W/kg

**SAR(1 g) = 5.44 W/kg; SAR(10 g) = 2.34 W/kg**

Maximum value of SAR (measured) = 12.2 W/kg

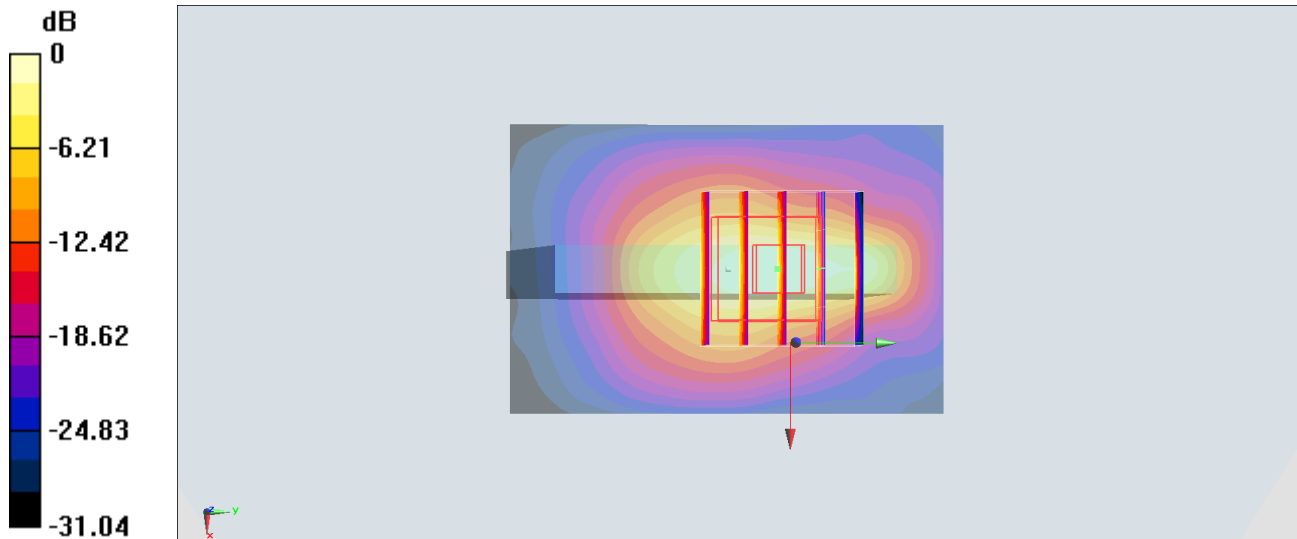

0 dB = 12.2 W/kg = 10.86 dBW/kg

**#35\_LTE Band 4\_20M\_QPSK\_1\_0\_Bottom Side\_0mm\_Ch20175**

Communication System: LTE ; Frequency: 1732.5 MHz;Duty Cycle: 1:1

Medium: HSL\_1750\_200527 Medium parameters used:  $f = 1733$  MHz;  $\sigma = 1.354$  S/m;  $\epsilon_r = 40.635$ ;  $\rho = 1000$  kg/m<sup>3</sup>

Ambient Temperature : 23.4 °C ; Liquid Temperature : 22.4 °C

DASY5 Configuration:

- Probe: EX3DV4 - SN7306; ConvF(8.51, 8.51, 8.51) @ 1732.5 MHz; Calibrated: 2019/7/22
- Sensor-Surface: 1.4mm (Mechanical Surface Detection)
- Electronics: DAE4 Sn679; Calibrated: 2020/5/6
- Phantom: SAM\_Left; Type: QD000P40CD; Serial: TP:1815
- Measurement SW: DASY52, Version 52.10 (4);SEMCAD X Version 14.6.14 (7483)

**Area Scan (41x61x1):** Interpolated grid: dx=1.500 mm, dy=1.500 mm

Maximum value of SAR (interpolated) = 12.4 W/kg

**Zoom Scan (5x5x7)/Cube 0:** Measurement grid: dx=8mm, dy=8mm, dz=5mm

Reference Value = 1.971 V/m; Power Drift = 0.17 dB

Peak SAR (extrapolated) = 14.0 W/kg

**SAR(1 g) = 5.35 W/kg; SAR(10 g) = 2.32 W/kg**

Maximum value of SAR (measured) = 10.8 W/kg

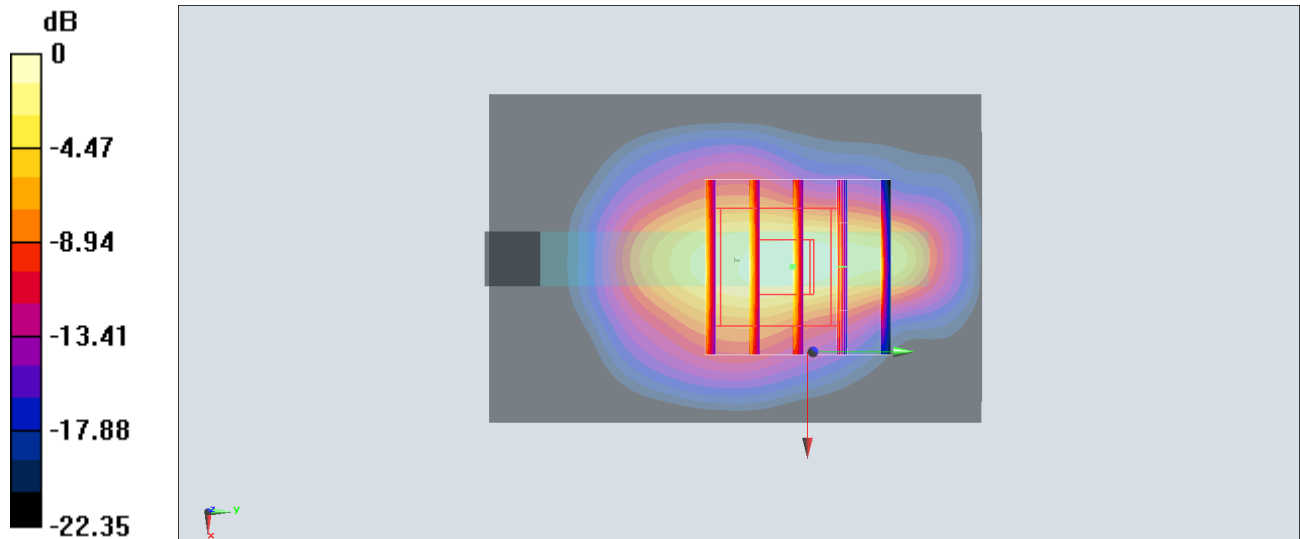

0 dB = 12.4 W/kg = 10.93 dBW/kg

**#36\_WLAN5GHz\_802.11ac-VHT80 MCS0\_Back\_0mm\_Ch58**

Communication System: 802.11ac ; Frequency: 5290 MHz; Duty Cycle: 1:1.159

Medium: HSL\_5G\_200523 Medium parameters used:  $f = 5290$  MHz;  $\sigma = 4.716$  S/m;  $\epsilon_r = 36.561$ ;  $\rho = 1000$  kg/m<sup>3</sup>

Ambient Temperature : 23.3 °C ; Liquid Temperature : 22.3 °C

DASY5 Configuration:

- Probe: EX3DV4 - SN3642; ConvF(4.43, 4.43, 4.43) @ 5290 MHz; Calibrated: 2020/4/29
- Sensor-Surface: 1.4mm (Mechanical Surface Detection)
- Electronics: DAE4 Sn913; Calibrated: 2020/5/6
- Phantom: SAM\_Left; Type: QD000P40CD; Serial: TP:1801
- Measurement SW: DASY52, Version 52.10 (4); SEMCAD X Version 14.6.14 (7483)

**Area Scan (121x121x1):** Interpolated grid: dx=1.000 mm, dy=1.000 mm

Maximum value of SAR (interpolated) = 1.24 W/kg

**Zoom Scan (7x7x7)/Cube 0:** Measurement grid: dx=4mm, dy=4mm, dz=1.4mm

Reference Value = 0 V/m; Power Drift = 0.11 dB

Peak SAR (extrapolated) = 22.0 W/kg

**SAR(1 g) = 2.27 W/kg; SAR(10 g) = 0.423 W/kg**

Maximum value of SAR (measured) = 8.51 W/kg

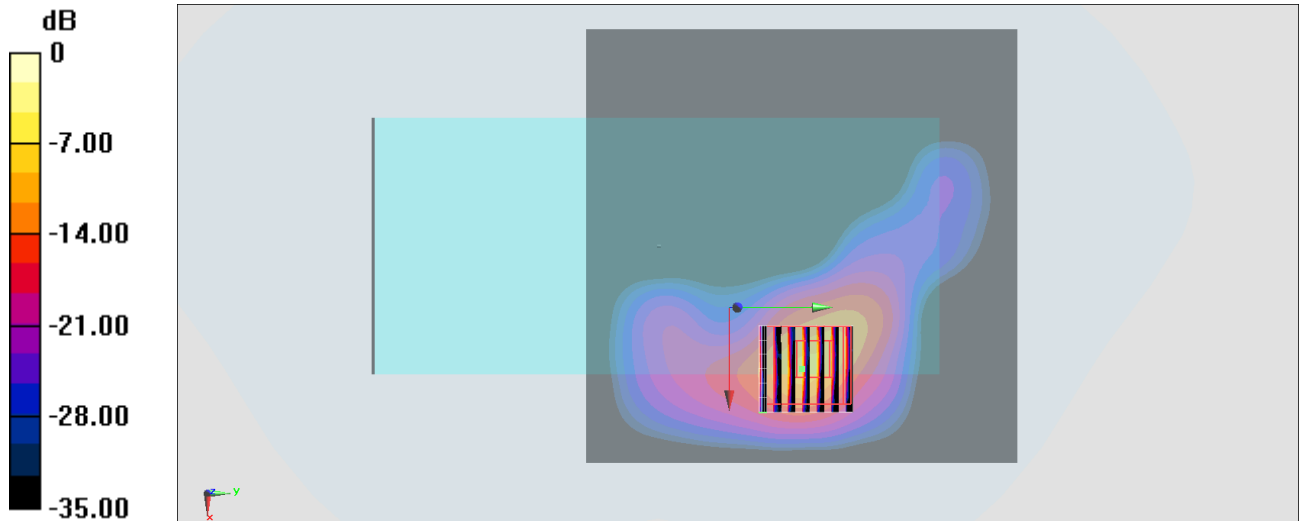

0 dB = 8.51 W/kg = 9.30 dBW/kg

### #37\_WLAN5GHz\_802.11ac-VHT80 MCS0\_Back\_0mm\_Ch122

Communication System:802.11ac ; Frequency: 5610 MHz;Duty Cycle: 1:1.159

Medium: HSL\_5G\_200523 Medium parameters used :  $f = 5610$  MHz;  $\sigma = 5.069$  S/m;  $\epsilon_r = 36.425$ ;  $\rho = 1000$  kg/m<sup>3</sup>

Ambient Temperature : 23.3 °C ; Liquid Temperature : 22.3 °C

DASY5 Configuration:

- Probe: EX3DV4 - SN3642;ConvF(4.19, 4.19, 4.19) @ 5610 MHz;Calibrated: 2020/4/29
- Sensor-Surface: 1.4mm (Mechanical Surface Detection)
- Electronics: DAE4 Sn913; Calibrated: 2020/5/6
- Phantom: SAM\_Left; Type: QD000P40CD; Serial: TP:1801
- Measurement SW: DASY52, Version 52.10 (4);SEMCAD X Version 14.6.14 (7483)

**Area Scan (121x121x1):** Interpolated grid: dx=1.000 mm, dy=1.000 mm

Maximum value of SAR (interpolated) = 0.351 W/kg

**Zoom Scan (7x7x7)/Cube 0:** Measurement grid: dx=4mm, dy=4mm, dz=1.4mm

Reference Value = 0 V/m; Power Drift = 0.14 dB

Peak SAR (extrapolated) = 22.1 W/kg

**SAR(1 g) = 2.52 W/kg; SAR(10 g) = 0.510 W/kg**

Maximum value of SAR (measured) = 8.79 W/kg

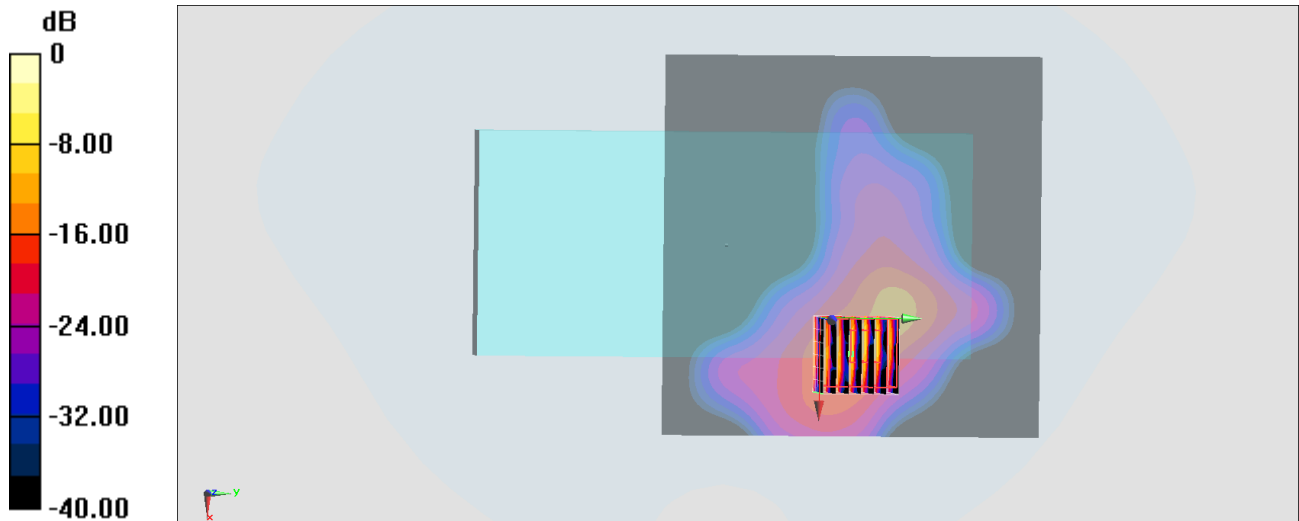

0 dB = 8.79 W/kg = 9.44 dBW/kg