



FCC RADIO TEST REPORT

FCC ID : APYHRO00276
Equipment : Smart phone
Brand Name : SHARP
Applicant : SHARP CORPORATION
2-13-1, Hachihonmatsu-lida, Higashi-hiroshima-shi,
Hiroshima pref. 739-0192, Japan
Manufacturer : SHARP CORPORATION
1 Takumi-Cho, Sakai-Ku, Sakai-Shi, Osaka 590-8522, Japan
Standard : 47 CFR Part 2, 22(H), 27

The product was received on Jul. 16, 2019 and testing was started from Jul. 22, 2019 and completed on Aug. 06, 2019. We, SPORTON INTERNATIONAL INC. EMC & Wireless Communications Laboratory, would like to declare that the tested sample has been evaluated in accordance with the test procedures given in ANSI / TIA-603-E and has been in compliance with the applicable technical standards.

The report must not be used by the client to claim product certification, approval, or endorsement by TAF or any agency of government.

The test results in this report apply exclusively to the tested model / sample. Without written approval of SPORTON INTERNATIONAL INC. EMC & Wireless Communications Laboratory, the test report shall not be reproduced except in full.

Louis Wu

Approved by: Louis Wu

SPORTON INTERNATIONAL INC. EMC & Wireless Communications Laboratory
No. 52, Huaya 1st Rd., Guishan Dist., Taoyuan City, Taiwan (R.O.C.)



Table of Contents

History of this test report..... 3

Summary of Test Result..... 4

1 General Description 5

 1.1 Product Feature of Equipment Under Test..... 5

 1.2 Modification of EUT 5

 1.3 Testing Location 6

 1.4 Applicable Standards..... 6

2 Test Configuration of Equipment Under Test 7

 2.1 Test Mode..... 7

 2.2 Connection Diagram of Test System..... 8

 2.3 Support Unit used in test configuration and system 8

 2.4 Measurement Results Explanation Example..... 8

 2.5 Frequency List of Low/Middle/High Channels 9

3 Conducted Test Items..... 10

 3.1 Measuring Instruments 10

 3.2 Conducted Output Power and EIRP 11

 3.3 Peak-to-Average Ratio 12

 3.4 Occupied Bandwidth..... 13

 3.5 Conducted Band Edge 14

 3.6 Conducted Spurious Emission 15

 3.7 Frequency Stability 16

4 Radiated Test Items 17

 4.1 Measuring Instruments 17

 4.2 Radiated Spurious Emission Measurement 18

5 List of Measuring Equipment..... 19

6 Uncertainty of Evaluation..... 20

Appendix A. Test Results of Conducted Test

Appendix B. Test Results of EIRP and Radiated Test

Appendix C. Test Setup Photographs



History of this test report

Report No.	Version	Description	Issued Date
FG971613B	01	Initial issue of report	Aug. 21, 2019



Summary of Test Result

Report Clause	Ref Std. Clause	Test Items	Result (PASS/FAIL)	Remark
3.2	§2.1046	Conducted Output Power	Reporting only	-
	§22.913 (a)(2)	Effective Radiated Power (Band 5)	Pass	
	§27.50 (c)(10)	Effective Radiated Power (Band 12) (Band 17)		
3.3	-	Peak-to-Average Ratio	Reporting only	-
3.4	§2.1049	Occupied Bandwidth	Reporting only	-
3.5	§2.1051 §22.917 (a) §27.53 (g)	Conducted Band Edge Measurement (Band 5) (Band 12) (Band 17)	Pass	-
3.6	§2.1051 §22.917 (a) §27.53 (g)	Conducted Spurious Emission (Band 5) (Band 12) (Band 17)	Pass	-
3.7	§2.1055 §22.355 §27.54	Frequency Stability Temperature & Voltage	Pass	-
4.2	§2.1053 §22.917 (a) §27.53 (g)	Radiated Spurious Emission (Band 5) (Band 12) (Band 17)	Pass	Under limit 39.28 dB at 1680.000 MHz

Declaration of Conformity:
The test results with all measurement uncertainty excluded are presented in accordance with the regulation limits or requirements declared by manufacturers.
Comments and Explanations:
The declared of product specification for EUT presented in the report are provided by the manufacturer, and the manufacturer takes all the responsibilities for the accuracy of product specification.

Reviewed by: Wii Chang

Report Producer: Yimin Ho



1 General Description

1.1 Product Feature of Equipment Under Test

GSM/WCDMA/LTE, Bluetooth, Wi-Fi 2.4GHz 802.11b/g/n, Wi-Fi 5GHz 802.11a/n/ac, NFC, and GNSS.

Product Specification subjective to this standard	
Sample 1	1st vender parts
Sample 2	2nd vender parts
Antenna Type	WWAN: PIFA Antenna WLAN: ILA Antenna Bluetooth: ILA Antenna GPS / Glonass / BDS / Galileo: ILA Antenna NFC: Loop Antenna

Remark: All test items were performed with Sample 1.

1.2 Modification of EUT

No modifications are made to the EUT during all test items.



1.3 Testing Location

Test Site	SPORTON INTERNATIONAL INC. EMC & Wireless Communications Laboratory
Test Site Location	No.52, Huaya 1st Rd., Guishan Dist., Taoyuan City, Taiwan (R.O.C.) TEL: +886-3-327-3456 FAX: +886-3-328-4978
Test Site No.	Sporton Site No.
	TH05-HY
Test Engineer	Jacky Wang
Temperature	23~25°C
Relative Humidity	55~57%

Note: The test site complies with ANSI C63.4 2014 requirement.

Test Site	SPORTON INTERNATIONAL INC. EMC & Wireless Communications Laboratory
Test Site Location	No.58, Aly. 75, Ln. 564, Wenhua 3rd, Rd., Guishan Dist., Taoyuan City, Taiwan (R.O.C.) TEL: +886-3-327-0868 FAX: +886-3-327-0855
Test Site No.	Sporton Site No.
	03CH11-HY
Test Engineer	Bill Kuo, Fu Chen, Troye Hsieh
Temperature	21.6~26°C
Relative Humidity	54.6~66.3%

Note: The test site complies with ANSI C63.4 2014 requirement.

FCC Designation No.: TW1190 and TW0007

1.4 Applicable Standards

According to the specifications of the manufacturer, the EUT must comply with the requirements of the following standards:

- ♦ ANSI C63.26-2015
- ♦ ANSI / TIA-603-E
- ♦ 47 CFR Part 2, 22(H), 27
- ♦ FCC KDB 971168 D01 Power Meas. License Digital Systems v03r01
- ♦ FCC KDB 412172 D01 Determining ERP and EIRP v01r01

Remark:

1. All test items were verified and recorded according to the standards and without any deviation during the test.
2. This EUT has also been tested and complied with the requirements of FCC Part 15, Subpart B, recorded in a separate test report.



2 Test Configuration of Equipment Under Test

2.1 Test Mode

Antenna port conducted and radiated test items listed below are performed according to KDB 971168 D01 Power Meas. License Digital Systems v03r01 with maximum output power.

For radiated measurement, pre-scanned in three orthogonal panels, X, Y, Z. The worst cases (X plane for LTE Band 17, Y plane for LTE Band 12 and Z plane for LTE Band 5) were recorded in this report.

Test Items	Band	Bandwidth (MHz)						Modulation			RB #			Test Channel		
		1.4	3	5	10	15	20	QPSK	16QAM	64QAM	1	Half	Full	L	M	H
Max. Output Power	5	v	v	v	v	-	-	v	v	v	v	v	v	v	v	v
	12	v	v	v	v	-	-	v	v	v	v	v	v	v	v	v
	17	-	-	v	v	-	-	v	v	v	v	v	v	v	v	v
Peak-to-Average Ratio	5				v	-	-	v	v	v	v		v	v	v	v
	12				v	-	-	v	v	v	v		v	v	v	v
	17	-	-		v	-	-	v	v	v	v		v	v	v	v
26dB and 99% Bandwidth	5	v	v	v	v	-	-	v	v	v			v	v	v	v
	12	v	v	v	v	-	-	v	v	v			v	v	v	v
	17	-	-	v	v	-	-	v	v	v			v	v	v	v
Conducted Band Edge	5	v	v	v	v	-	-	v	v	v	v		v	v		v
	12	v	v	v	v	-	-	v	v	v	v		v	v		v
	17	-	-	v	v	-	-	v	v	v	v		v	v		v
Conducted Spurious Emission	5	v	v	v	v	-	-	v	v	v	v			v	v	v
	12	v	v	v	v	-	-	v	v	v	v			v	v	v
	17	-	-	v	v	-	-	v	v	v	v			v	v	v
Frequency Stability	5				v	-	-	v					v		v	
	12				v	-	-	v					v		v	
	17	-	-		v	-	-	v					v		v	
E.R.P.	5	v	v	v	v	-	-	v	v	v	v			v	v	v
	12	v	v	v	v	-	-	v	v	v	v			v	v	v
	17	-	-	v	v	-	-	v	v	v	v			v	v	v
Radiated Spurious Emission	5	Worst Case											v	v	v	
	12	Worst Case											v	v	v	
	17	Worst Case											v	v	v	
Remark	<ol style="list-style-type: none"> The mark "v" means that this configuration is chosen for testing The mark "-" means that this bandwidth is not supported. The device is investigated from 30MHz to 10 times of fundamental signal for radiated spurious emission test under different RB size/offset and modulations in exploratory test. Subsequently, only the worst case emissions are reported. 															

2.2 Connection Diagram of Test System

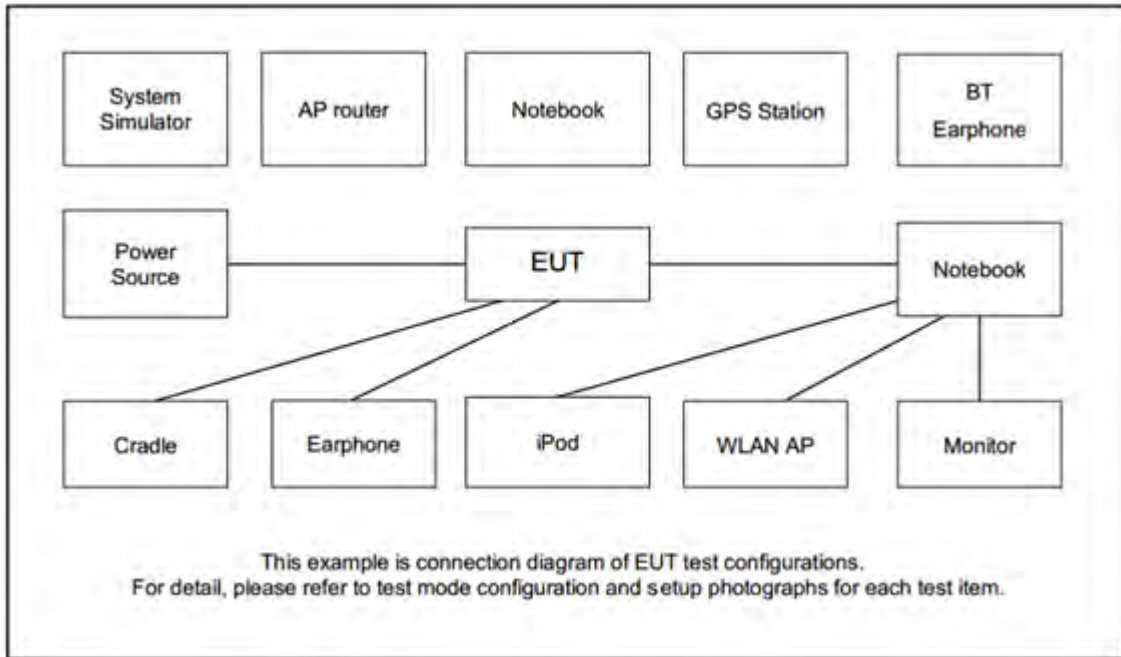

2.3 Support Unit used in test configuration and system

Item	Equipment	Trade Name	Model No.	FCC ID	Data Cable	Power Cord
1.	System Simulator	Anritsu	MT8820C	N/A	N/A	Unshielded, 1.8 m
2.	Earphone	SHARP	RPHOEA007AFZZ	N/A	Unshielded, 1.2m	N/A

2.4 Measurement Results Explanation Example

For all conducted test items:

The offset level is set in the spectrum analyzer to compensate the RF cable loss and attenuator factor between EUT conducted output port and spectrum analyzer. With the offset compensation, the spectrum analyzer reading level is exactly the EUT RF output level.

The spectrum analyzer offset is derived from RF cable loss and attenuator factor.

Offset = RF cable loss + attenuator factor.

Following shows an offset computation example with cable loss 4.2 dB and 10dB attenuator.

Example :

$$\begin{aligned} \text{Offset(dB)} &= \text{RF cable loss(dB)} + \text{attenuator factor(dB)}. \\ &= 4.2 + 10 = 14.2 \text{ (dB)} \end{aligned}$$



2.5 Frequency List of Low/Middle/High Channels

LTE Band 5 Channel and Frequency List				
BW [MHz]	Channel/Frequency(MHz)	Lowest	Middle	Highest
10	Channel	20450	20525	20600
	Frequency	829	836.5	844
5	Channel	20425	20525	20625
	Frequency	826.5	836.5	846.5
3	Channel	20415	20525	20635
	Frequency	825.5	836.5	847.5
1.4	Channel	20407	20525	20643
	Frequency	824.7	836.5	848.3

LTE Band 12 Channel and Frequency List				
BW [MHz]	Channel/Frequency(MHz)	Lowest	Middle	Highest
10	Channel	23060	23095	23130
	Frequency	704	707.5	711
5	Channel	23035	23095	23155
	Frequency	701.5	707.5	713.5
3	Channel	23025	23095	23165
	Frequency	700.5	707.5	714.5
1.4	Channel	23017	23095	23173
	Frequency	699.7	707.5	715.3

LTE Band 17 Channel and Frequency List				
BW [MHz]	Channel/Frequency(MHz)	Lowest	Middle	Highest
10	Channel	23780	23790	23800
	Frequency	709	710	711
5	Channel	23755	23790	23825
	Frequency	706.5	710	713.5

3 Conducted Test Items

3.1 Measuring Instruments

See list of measuring instruments of this test report.

3.1.1 Test Setup

3.1.2 Conducted Output Power



3.1.3 Peak-to-Average Ratio, Occupied Bandwidth ,Conducted Band-Edge and Conducted Spurious Emission

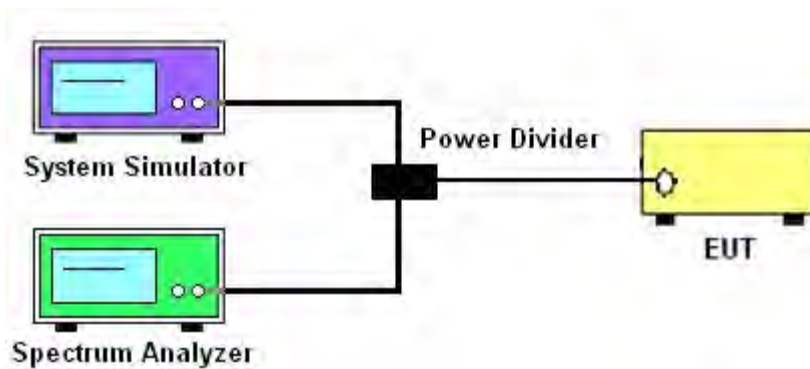

3.1.4 Frequency Stability

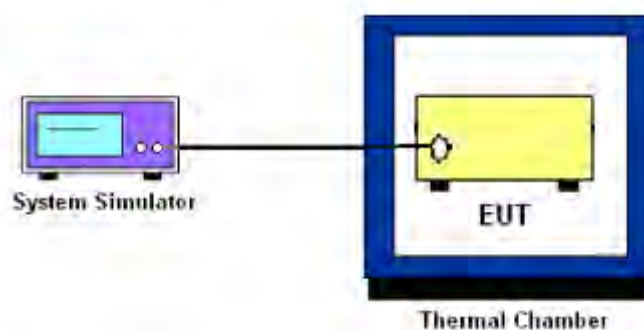

3.1.5 Test Result of Conducted Test

Please refer to Appendix A.



3.2 Conducted Output Power and EIRP

3.2.1 Description of the Conducted Output Power Measurement and EIRP Measurement

A system simulator was used to establish communication with the EUT. Its parameters were set to force the EUT transmitting at maximum output power. The measured power in the radio frequency on the transmitter output terminals shall be reported.

The ERP of mobile transmitters must not exceed 7 Watts for LTE Band 5.

The ERP of mobile transmitters must not exceed 3 Watts for LTE Band 12 and Band 17.

According to KDB 412172 D01 Power Approach,

$EIRP = P_T + G_T - L_C$, $ERP = EIRP - 2.15$, where

P_T = transmitter output power in dBm

G_T = gain of the transmitting antenna in dBi

L_C = signal attenuation in the connecting cable between the transmitter and antenna in dB

3.2.2 Test Procedures

1. The transmitter output port was connected to the system simulator.
2. Set EUT at maximum power through the system simulator.
3. Select lowest, middle, and highest channels for each band and different modulation.
4. Measure and record the power level from the system simulator.



3.3 Peak-to-Average Ratio

3.3.1 Description of the PAR Measurement

Power Complementary Cumulative Distribution Function (CCDF) curves provide a means for characterizing the power peaks of a digitally modulated signal on a statistical basis. A CCDF curve depicts the probability of the peak signal amplitude exceeding the average power level. Most contemporary measurement instrumentation include the capability to produce CCDF curves for an input signal provided that the instrument's resolution bandwidth can be set wide enough to accommodate the entire input signal bandwidth. In measuring transmissions in this band using an average power technique, the peak-to-average ratio (PAR) of the transmission may not exceed 13 dB.

3.3.2 Test Procedures

The testing follows ANSI C63.26-2015 Section 5.2.6

1. The EUT was connected to spectrum and system simulator via a power divider.
2. Set the CCDF (Complementary Cumulative Distribution Function) option in spectrum analyzer.
3. The highest RF powers were measured and recorded the maximum PAPR level associated with a probability of 0.1 %.
4. Record the deviation as Peak to Average Ratio.



3.4 Occupied Bandwidth

3.4.1 Description of Occupied Bandwidth Measurement

The occupied bandwidth is the width of a frequency band such that, below the lower and above the upper frequency limits, the mean powers emitted are each equal to a specified percentage 0.5% of the total mean transmitted power.

The 26 dB emission bandwidth is defined as the frequency range between two points, one above and one below the carrier frequency, at which the spectral density of the emission is attenuated 26 dB below the maximum in-band spectral density of the modulated signal. Spectral density (power per unit bandwidth) is to be measured with a detector of resolution bandwidth equal to approximately 1.0% of the emission bandwidth.

3.4.2 Test Procedures

The testing follows ANSI C63.26-2015 Section 5.4.3 (26dB) and Section 5.4.4 (99OB)

1. The EUT was connected to spectrum analyzer and system simulator via a power divider.
2. The spectrum analyzer center frequency is set to the nominal EUT channel center frequency. The span range for the spectrum analyzer shall be between two and five times the anticipated OBW.
3. The nominal resolution bandwidth (RBW) shall be in the range of 1 to 5 % of the anticipated OBW, and the VBW shall be at least 3 times the RBW.
4. Set the detection mode to peak, and the trace mode to max hold.
5. Determine the reference value: Set the EUT to transmit a modulated signal. Allow the trace to stabilize. Set the spectrum analyzer marker to the highest level of the displayed trace.
(this is the reference value)
6. Determine the "-26 dB down amplitude" as equal to (Reference Value - X).
7. Place two markers, one at the lowest and the other at the highest frequency of the envelope of the spectral display such that each marker is at or slightly below the "-X dB down amplitude" determined in step 6. If a marker is below this "-X dB down amplitude" value it shall be placed as close as possible to this value. The OBW is the positive frequency difference between the two markers.
8. Use the 99 % power bandwidth function of the spectrum analyzer and report the measured bandwidth.



3.5 Conducted Band Edge

3.5.1 Description of Conducted Band Edge Measurement

22.917(a)

For operations in the 824 – 849 MHz band, the FCC limit is $43 + 10\log_{10}(P[\text{Watts}])$ dB below the transmitter power $P(\text{Watts})$ in a 100kHz bandwidth. However, in the 1MHz bands immediately outside and adjacent to the licensee's frequency block, a resolution bandwidth of at least one percent of the emission bandwidth of the fundamental emission of the transmitter may be employed.

27.53 (g)

For operations in the 600MHz band and 698 -746 MHz band, the FCC limit is $43 + 10\log_{10}(P[\text{Watts}])$ dB below the transmitter power $P(\text{Watts})$ in a 100 kHz bandwidth. However, in the 100 kilohertz bands immediately outside and adjacent to a licensee's frequency block, a resolution bandwidth of at least 30 kHz may be employed.

3.5.2 Test Procedures

The testing follows FCC KDB 971168 D01 v03r01 Section 6.1.

1. The EUT was connected to spectrum analyzer and system simulator via a power divider.
2. The band edges of low and high channels for the highest RF powers were measured.
3. Set RBW \geq 1% EBW in the 1MHz band immediately outside and adjacent to the band edge.
4. Beyond the 1 MHz band from the band edge, RBW=1MHz was used.
5. Set spectrum analyzer with RMS detector.
6. The RF fundamental frequency should be excluded against the limit line in the operating frequency band.
7. Checked that all the results comply with the emission limit line.

The limit line is derived from $43 + 10\log(P)\text{dB}$ below the transmitter power $P(\text{Watts})$



3.6 Conducted Spurious Emission

3.6.1 Description of Conducted Spurious Emission Measurement

The power of any emission outside of the authorized operating frequency ranges must be lower than the transmitter power (P) by a factor of at least $43 + 10 \log (P)$ dB.

It is measured by means of a calibrated spectrum analyzer and scanned from 30 MHz up to a frequency including its 10th harmonic.

3.6.2 Test Procedures

The testing follows FCC KDB 971168 D01 v03r01 Section 6.1.

1. The EUT was connected to spectrum analyzer and system simulator via a power divider.
2. The RF output of EUT was connected to the spectrum analyzer by RF cable and attenuator. The path loss was compensated to the results for each measurement.
3. The middle channel for the highest RF power within the transmitting frequency was measured.
4. The conducted spurious emission for the whole frequency range was taken.
5. Make the measurement with the spectrum analyzer's RBW = 1MHz, VBW = 3MHz.
6. Set spectrum analyzer with RMS detector.
7. Taking the record of maximum spurious emission.
8. The RF fundamental frequency should be excluded against the limit line in the operating frequency band.
9. The limit line is derived from $43 + 10\log(P)$ dB below the transmitter power P(Watts)



3.7 Frequency Stability

3.7.1 Description of Frequency Stability Measurement

22.355

The frequency stability shall be measured by variation of ambient temperature and variation of primary supply voltage to ensure that the fundamental emission stays within the authorized frequency block. The frequency stability of the transmitter shall be maintained within $\pm 0.00025\%$ ($\pm 2.5\text{ppm}$) of the center frequency.

27.54

The frequency stability shall be sufficient to ensure that the fundamental emission stays within the authorized frequency block.

3.7.2 Test Procedures for Temperature Variation

The testing follows FCC KDB 971168 D01 v03r01 Section 9.0.

1. The EUT was set up in the thermal chamber and connected with the system simulator.
2. With power OFF, the temperature was decreased to -30°C and the EUT was stabilized before testing. Power was applied and the maximum change in frequency was recorded within one minute.
3. With power OFF, the temperature was raised in 10°C step up to 50°C . The EUT was stabilized at each step for at least half an hour. Power was applied and the maximum frequency change was recorded within one minute.

3.7.3 Test Procedures for Voltage Variation

The testing follows FCC KDB 971168 D01 v03r01 Section 9.0.

1. The EUT was placed in a temperature chamber at $20\pm 5^{\circ}\text{C}$ and connected with the system simulator.
2. The power supply voltage to the EUT was varied from 85% to 115% of the nominal value measured at the input to the EUT.
3. The variation in frequency was measured for the worst case.

4 Radiated Test Items

4.1 Measuring Instruments

See list of measuring instruments of this test report.

4.1.1 Test Setup

For radiated test from 30MHz to 1GHz

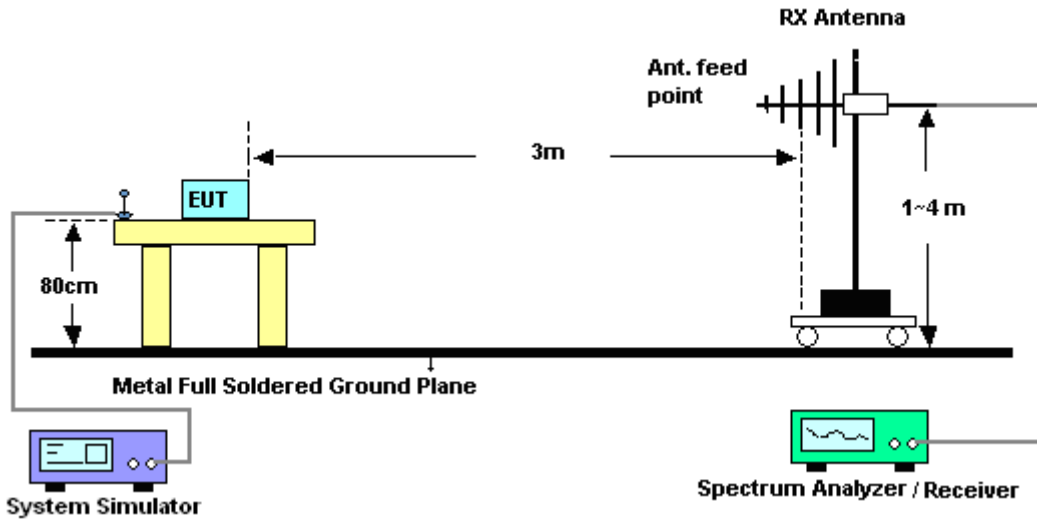

For radiated test above 1GHz

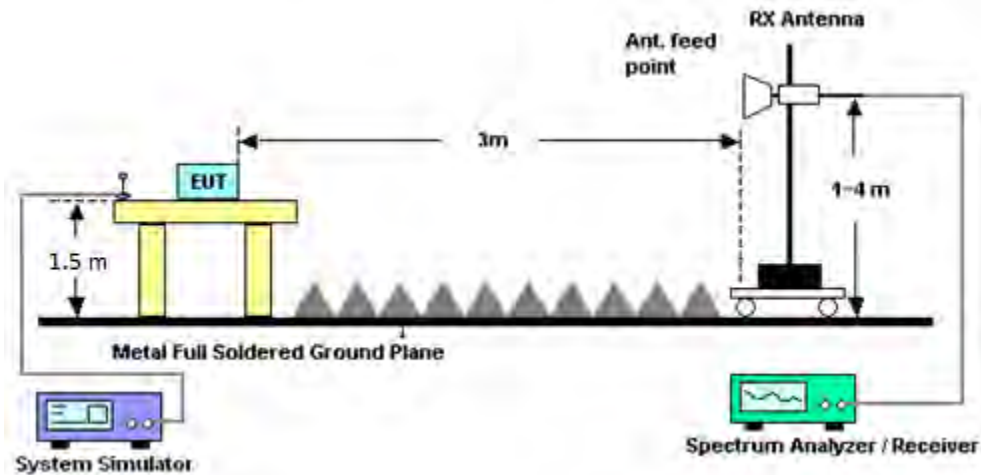

4.1.2 Test Result of Radiated Test

Please refer to Appendix B.



4.2 Radiated Spurious Emission Measurement

4.2.1 Description of Radiated Spurious Emission Measurement

The radiated spurious emission was measured by substitution method according to ANSI / TIA-603-E. The power of any emission outside of the authorized operating frequency ranges must be attenuated below the transmitter power (P) by a factor of at least $43 + 10 \log (P)$ dB.

The spectrum is scanned from 30 MHz up to a frequency including its 10th harmonic.

4.2.2 Test Procedures

The testing follows FCC KDB 971168 D01 v03r01 Section 7 and ANSI / TIA-603-E Section 2.2.12.

1. The EUT was placed on a turntable with 0.8 meter for frequency below 1GHz and 1.5 meter for frequency above 1GHz respectively above ground.
2. The EUT was set 3 meters from the receiving antenna, which was mounted on the antenna tower.
3. The table was rotated 360 degrees to determine the position of the highest spurious emission.
4. The height of the receiving antenna is varied between one meter and four meters to search the maximum spurious emission for both horizontal and vertical polarizations.
5. Make the measurement with the spectrum analyzer's RBW = 1MHz, VBW = 3MHz, taking the record of maximum spurious emission.
6. A horn antenna was substituted in place of the EUT and was driven by a signal generator.
7. Tune the output power of signal generator to the same emission level with EUT maximum spurious emission.
8. Taking the record of output power at antenna port.
9. Repeat step 7 to step 8 for another polarization.
10. The RF fundamental frequency should be excluded against the limit line in the operating frequency band.

The limit line is derived from $43 + 10\log(P)$ dB below the transmitter power P(Watts)



5 List of Measuring Equipment

Instrument	Manufacturer	Model No.	Serial No.	Characteristics	Calibration Date	Test Date	Due Date	Remark
Preamplifier	EMEC	EM18G40G	060715	18GHz ~ 40GHz	Dec. 06, 2018	Jul. 27, 2019~ Aug. 06, 2019	Dec. 05, 2019	Radiation (03CH11-HY)
Amplifier	SONOMA	310N	187312	9kHz~1GHz	Dec. 04, 2018	Jul. 27, 2019~ Aug. 06, 2019	Dec. 03, 2019	Radiation (03CH11-HY)
Bilog Antenna	TESEQ	CBL 6111D&N-6-0 6	35414&AT- N0602	30MHz~1GHz	Oct. 13, 2018	Jul. 27, 2019~ Aug. 06, 2019	Oct. 12, 2019	Radiation (03CH11-HY)
Horn Antenna	SCHWARZBE CK	BBHA 9120 D	9120D-132 6	1GHz ~ 18GHz	Oct. 15, 2018	Jul. 27, 2019~ Aug. 06, 2019	Oct. 14, 2019	Radiation (03CH11-HY)
Horn Antenna	SCHWARZBE CK	BBHA 9120D	9120D-132 8	1GHz ~ 18GHz	Nov. 09, 2018	Jul. 27, 2019~ Aug. 06, 2019	Nov. 08, 2019	Radiation (03CH11-HY)
Loop Antenna	Rohde & Schwarz	HFH2-Z2	100488	9 kHz~30 MHz	Nov. 23, 2017	Jul. 27, 2019~ Aug. 06, 2019	Nov. 22, 2019	Radiation (03CH11-HY)
Preamplifier	Keysight	83017A	MY532701 48	1GHz~26.5GHz	Nov. 14, 2018	Jul. 27, 2019~ Aug. 06, 2019	Nov. 13, 2019	Radiation (03CH11-HY)
Spectrum Analyzer	Keysight	N9010A	MY542004 86	10Hz ~ 44GHz	Oct. 18, 2018	Jul. 27, 2019~ Aug. 06, 2019	Oct. 17, 2019	Radiation (03CH11-HY)
Filter	Wainwright	WHKX12-108 0-1200-1500- 60SS	SN2	1.2G High Pass	Sep. 17, 2018	Jul. 27, 2019~ Aug. 06, 2019	Sep. 16, 2019	Radiation (03CH11-HY)
Filter	Wainwright	WHKX12-270 0-3000-18000 -60SS	SN3	2.7G High Pass	Sep. 17, 2018	Jul. 27, 2019~ Aug. 06, 2019	Sep. 16, 2019	Radiation (03CH11-HY)
Antenna Mast	EMEC	AM-BS-4500- B	N/A	1~4m	N/A	Jul. 27, 2019~ Aug. 06, 2019	N/A	Radiation (03CH11-HY)
Turn Table	EMEC	TT 2000	N/A	0~360 Degree	N/A	Jul. 27, 2019~ Aug. 06, 2019	N/A	Radiation (03CH11-HY)
EMI Test Receiver	Keysight	N9038A (MXE)	MY532900 45	20MHz~8.4GHz	Jan. 19, 2019	Jul. 27, 2019~ Aug. 06, 2019	Jan. 18, 2020	Radiation (03CH11-HY)
SHF-EHF Horn Antenna	SCHWARZBE CK	BBHA 9170	BBHA9170 584	18GHz- 40GHz	Dec. 05, 2018	Jul. 27, 2019~ Aug. 06, 2019	Dec. 04, 2019	Radiation (03CH11-HY)
Software	Audix	E3 6.2009-8-24	RK-00104 2	N/A	N/A	Jul. 27, 2019~ Aug. 06, 2019	N/A	Radiation (03CH11-HY)
RF Cable	HUBER + SUHNER	SUCOFLEX 104	MY9837/4 PE	9kHz-30MHz	Mar. 13, 2019	Jul. 27, 2019~ Aug. 06, 2019	Mar. 12, 2020	Radiation (03CH11-HY)
RF Cable	HUBER + SUHNER	SUCOFLEX 102	MY2859/2	30MHz-40GHz	Mar. 13, 2019	Jul. 27, 2019~ Aug. 06, 2019	Mar. 12, 2020	Radiation (03CH11-HY)
RF Cable	HUBER + SUHNER	SUCOFLEX 104	MY9837/4 PE	30M-18G	Mar. 13, 2019	Jul. 27, 2019~ Aug. 06, 2019	Mar. 12, 2020	Radiation (03CH11-HY)
RF Cable	HUBER + SUHNER	SUCOFLEX 102	MY4274/2	30MHz-40GHz	Mar. 13, 2019	Jul. 27, 2019~ Aug. 06, 2019	Mar. 12, 2020	Radiation (03CH11-HY)
SMB100A Signal Generator	R&S	SMB100A	181147	100kHz~40GHz	Nov. 12, 2018	Jul. 27, 2019~ Aug. 06, 2019	Nov. 10, 2020	Radiation (03CH11-HY)
Spectrum Analyzer	Rohde & Schwarz	FSV40	101397	10Hz~40GHz	Nov. 13, 2018	Jul. 22, 2019~ Jul. 27, 2019	Nov. 12, 2019	Conducted (TH05-HY)
Temperature Chamber	ESPEC	SH-641	92013720	-40℃~90℃	Aug. 29, 2018	Jul. 22, 2019~ Jul. 27, 2019	Aug. 28, 2019	Conducted (TH05-HY)
Programmable Power Supply	GW Instek	PSS-2005	EL890094	1V~20V 0.5A~5A	Oct. 02, 2018	Jul. 22, 2019~ Jul. 27, 2019	Oct. 01, 2019	Conducted (TH05-HY)
Coupler	Warison	20dB 25W SMA Directional Coupler	#A	1-18GHz	Jan. 14, 2019	Jul. 22, 2019~ Jul. 27, 2019	Jan. 13, 2020	Conducted (TH05-HY)



6 Uncertainty of Evaluation

Uncertainty of Radiated Emission Measurement (30 MHz ~ 1000 MHz)

Measuring Uncertainty for a Level of Confidence of 95% ($U = 2Uc(y)$)	3.37
---	------

Uncertainty of Radiated Emission Measurement (1 GHz ~ 18 GHz)

Measuring Uncertainty for a Level of Confidence of 95% ($U = 2Uc(y)$)	3.67
---	------

Uncertainty of Radiated Emission Measurement (18 GHz ~ 40 GHz)

Measuring Uncertainty for a Level of Confidence of 95% ($U = 2Uc(y)$)	4.03
---	------



Appendix A. Test Results of Conducted Test

Conducted Output Power(Average power)

LTE Band 5 Maximum Average Power [dBm]						
BW [MHz]	RB Size	RB Offset	Mod	Lowest	Middle	Highest
10	1	0	QPSK	23.03	23.18	23.14
10	1	25		23.05	23.13	23.17
10	1	49		23.13	23.12	23.16
10	25	0		22.18	22.23	22.13
10	25	12		22.29	22.28	22.26
10	25	25		22.19	22.17	22.22
10	50	0		22.15	22.25	22.10
10	1	0	16-QAM	22.30	22.32	22.39
10	1	25		22.47	22.47	22.49
10	1	49		22.50	22.46	22.59
10	25	0		21.30	21.33	21.24
10	25	12		21.41	21.27	21.39
10	25	25		21.30	21.18	21.43
10	50	0		21.28	21.25	21.21
10	1	0	64-QAM	21.33	21.40	21.37
10	1	25		21.39	21.49	21.50
10	1	49		21.50	21.39	21.49
10	25	0		20.33	20.32	20.25
10	25	12		20.35	20.34	20.44
10	25	25		20.38	20.33	20.40
10	50	0		20.36	20.28	20.31
5	1	0	QPSK	23.10	23.20	23.29
5	1	12		23.00	23.18	23.18
5	1	24		23.19	23.04	23.28
5	12	0		22.12	22.27	22.12
5	12	7		22.22	22.12	22.27
5	12	13		22.26	22.18	22.21
5	25	0		22.21	22.13	22.27
5	1	0	16-QAM	22.50	22.41	22.58
5	1	12		22.36	22.48	22.60
5	1	24		22.46	22.47	22.58
5	12	0		21.24	21.30	21.39
5	12	7		21.25	21.24	21.29
5	12	13		21.25	21.30	21.38
5	25	0		21.27	21.24	21.39
5	1	0	64-QAM	21.34	21.40	21.52
5	1	12		21.30	21.40	21.48
5	1	24		21.33	21.28	21.59
5	12	0		20.35	20.34	20.38
5	12	7		20.35	20.31	20.40
5	12	13		20.36	20.33	20.45
5	25	0		20.35	20.28	20.31



LTE Band 5 Maximum Average Power [dBm]						
BW [MHz]	RB Size	RB Offset	Mod	Lowest	Middle	Highest
3	1	0	QPSK	23.16	23.06	23.24
3	1	8		22.94	23.20	23.12
3	1	14		23.18	22.95	23.19
3	8	0		21.99	22.21	22.14
3	8	4		22.13	22.23	22.16
3	8	7		22.12	22.21	22.21
3	15	0		22.14	22.07	22.19
3	1	0	16-QAM	22.35	22.28	22.42
3	1	8		22.30	22.35	22.43
3	1	14		22.45	22.43	22.50
3	8	0		21.13	21.20	21.37
3	8	4		21.24	21.32	21.32
3	8	7		21.25	21.28	21.16
3	15	0		21.24	21.19	21.25
3	1	0	64-QAM	21.27	21.36	21.46
3	1	8		21.19	21.40	21.48
3	1	14		21.24	21.20	21.42
3	8	0		20.35	20.26	20.28
3	8	4		20.34	20.33	20.41
3	8	7		20.29	20.22	20.29
3	15	0		20.34	20.21	20.34
1.4	1	0	QPSK	22.98	23.09	23.07
1.4	1	3		23.00	22.97	23.06
1.4	1	5		22.89	23.11	23.09
1.4	3	0		23.11	23.00	23.02
1.4	3	1		23.10	23.09	23.00
1.4	3	3		23.16	22.92	22.99
1.4	6	0		21.92	22.18	22.01
1.4	1	0	16-QAM	22.14	21.89	21.94
1.4	1	3		22.02	21.88	22.19
1.4	1	5		22.00	21.95	22.06
1.4	3	0		22.12	21.97	22.15
1.4	3	1		22.03	22.01	22.14
1.4	3	3		22.01	21.99	22.04
1.4	6	0		21.17	21.02	21.14
1.4	1	0	64-QAM	21.09	20.95	21.07
1.4	1	3		21.19	20.98	21.04
1.4	1	5		21.04	20.90	21.13
1.4	3	0		21.13	21.08	21.12
1.4	3	1		21.19	20.89	21.11
1.4	3	3		20.95	21.13	21.09
1.4	6	0		20.17	20.05	20.27



LTE Band 12 Maximum Average Power [dBm]						
BW [MHz]	RB Size	RB Offset	Mod	Lowest	Middle	Highest
10	1	0	QPSK	23.05	22.96	23.08
10	1	25		23.16	23.08	23.17
10	1	49		23.18	23.09	23.10
10	25	0		22.20	22.08	22.20
10	25	12		22.21	22.10	22.21
10	25	25		22.12	22.16	22.10
10	50	0		22.22	22.11	22.14
10	1	0	16-QAM	22.45	22.34	22.47
10	1	25		22.49	22.45	22.48
10	1	49		22.48	22.54	22.47
10	25	0		21.31	21.32	21.30
10	25	12		21.32	21.27	21.25
10	25	25		21.28	21.22	21.28
10	50	0		21.26	21.26	21.21
10	1	0	64-QAM	21.30	21.38	21.40
10	1	25		21.48	21.42	21.33
10	1	49		21.46	21.37	21.43
10	25	0		20.27	20.28	20.31
10	25	12		20.28	20.36	20.28
10	25	25		20.31	20.20	20.35
10	50	0		20.27	20.20	20.23
5	1	0	QPSK	23.16	23.05	23.05
5	1	12		23.06	23.11	23.19
5	1	24		23.22	23.02	23.12
5	12	0		22.12	22.15	22.09
5	12	7		22.21	22.12	22.18
5	12	13		22.27	22.19	22.17
5	25	0		22.25	22.13	22.05
5	1	0	16-QAM	22.50	22.32	22.37
5	1	12		22.45	22.44	22.56
5	1	24		22.56	22.42	22.34
5	12	0		21.31	21.30	21.22
5	12	7		21.31	21.33	21.29
5	12	13		21.41	21.20	21.31
5	25	0		21.38	21.25	21.09
5	1	0	64-QAM	21.32	21.37	21.35
5	1	12		21.37	21.38	21.45
5	1	24		21.61	21.43	21.39
5	12	0		20.37	20.35	20.31
5	12	7		20.47	20.33	20.33
5	12	13		20.52	20.26	20.30
5	25	0		20.33	20.22	20.20



LTE Band 12 Maximum Average Power [dBm]						
BW [MHz]	RB Size	RB Offset	Mod	Lowest	Middle	Highest
3	1	0	QPSK	23.00	23.00	22.94
3	1	8		23.08	23.04	23.14
3	1	14		23.13	22.96	23.05
3	8	0		22.11	22.10	21.96
3	8	4		22.30	22.11	22.23
3	8	7		22.22	22.08	22.20
3	15	0		22.07	22.21	22.00
3	1	0	16-QAM	22.39	22.39	22.34
3	1	8		22.39	22.46	22.49
3	1	14		22.46	22.32	22.32
3	8	0		21.32	21.24	21.21
3	8	4		21.19	21.23	21.28
3	8	7		21.36	21.20	21.20
3	15	0		21.24	21.17	21.10
3	1	0	64-QAM	21.41	21.26	21.24
3	1	8		21.43	21.25	21.45
3	1	14		21.37	21.27	21.29
3	8	0		20.27	20.21	20.33
3	8	4		20.37	20.25	20.25
3	8	7		20.45	20.20	20.29
3	15	0		20.35	20.19	20.21
1.4	1	0	QPSK	22.89	23.04	22.94
1.4	1	3		22.96	23.14	23.02
1.4	1	5		22.76	23.16	22.96
1.4	3	0		23.07	22.82	23.09
1.4	3	1		22.97	23.02	23.05
1.4	3	3		23.15	22.92	22.83
1.4	6	0		22.13	22.08	22.01
1.4	1	0	16-QAM	22.22	22.01	22.02
1.4	1	3		21.89	22.00	22.23
1.4	1	5		21.92	21.92	22.05
1.4	3	0		22.04	21.89	22.10
1.4	3	1		22.09	22.10	22.19
1.4	3	3		21.97	21.96	22.01
1.4	6	0		21.22	21.04	21.19
1.4	1	0	64-QAM	21.13	20.91	21.18
1.4	1	3		21.16	20.83	21.08
1.4	1	5		21.21	20.82	21.11
1.4	3	0		21.03	20.94	21.07
1.4	3	1		21.23	20.77	21.04
1.4	3	3		21.02	21.05	21.02
1.4	6	0		20.25	20.03	20.22



LTE Band 17 Maximum Average Power [dBm]						
BW [MHz]	RB Size	RB Offset	Mod	Lowest	Middle	Highest
10	1	0	QPSK	22.88	22.89	22.91
10	1	25		22.90	22.87	22.88
10	1	49		22.98	23.05	22.96
10	25	0		21.92	21.92	21.91
10	25	12		21.93	21.94	21.94
10	25	25		21.90	21.91	21.92
10	50	0		21.91	21.90	21.91
10	1	0	16-QAM	22.26	22.25	22.26
10	1	25		22.23	22.23	22.25
10	1	49		22.36	22.30	22.27
10	25	0		21.02	21.02	21.01
10	25	12		21.04	21.03	21.04
10	25	25		21.01	21.02	21.02
10	50	0		21.04	21.04	21.04
10	1	0	64-QAM	21.20	21.18	21.20
10	1	25		21.19	21.16	21.17
10	1	49		21.27	21.24	21.21
10	25	0		20.05	20.05	20.04
10	25	12		20.05	20.06	20.05
10	25	25		20.06	20.05	20.04
10	50	0		20.07	20.06	20.06
5	1	0	QPSK	22.91	22.87	22.94
5	1	12		22.89	22.85	23.01
5	1	24		22.90	22.97	23.03
5	12	0		21.92	21.91	22.00
5	12	7		21.96	21.92	22.11
5	12	13		21.94	21.89	22.07
5	25	0		21.91	21.91	22.00
5	1	0	16-QAM	22.27	22.22	22.33
5	1	12		22.27	22.21	22.37
5	1	24		22.26	22.31	22.30
5	12	0		21.06	21.01	21.11
5	12	7		21.08	21.05	21.22
5	12	13		21.03	20.99	21.19
5	25	0		21.02	21.02	21.10
5	1	0	64-QAM	21.24	21.19	21.24
5	1	12		21.19	21.19	21.30
5	1	24		21.21	21.29	21.29
5	12	0		20.10	20.06	20.17
5	12	7		20.14	20.09	20.28
5	12	13		20.10	20.09	20.26
5	25	0		20.05	20.03	20.11



LTE Band 5

Peak-to-Average Ratio

Mode	LTE Band 5 / 10MHz				
Mod.	QPSK		16QAM		Limit: 13dB
RB Size	1RB	Full RB	1RB	Full RB	Result
Lowest CH	3.48	4.41	5.04	5.68	PASS
Middle CH	3.36	4.55	4.52	5.74	
Highest CH	3.57	4.72	4.93	6.03	
Mode	LTE Band 5 / 10MHz				
Mod.	64QAM				Limit: 13dB
RB Size	1RB	Full RB			Result
Lowest CH	5.83	6.20	-	-	PASS
Middle CH	6.17	6.32	-	-	
Highest CH	6.32	6.64	-	-	



LTE Band 5 / 10MHz / QPSK

Lowest Channel / 1RB



Date: 22.JUL.2019 22:31:00

Lowest Channel / Full RB

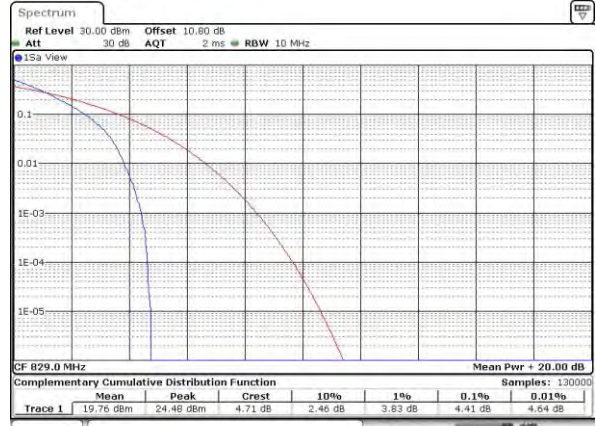

Date: 22.JUL.2019 22:31:11

Middle Channel / 1RB

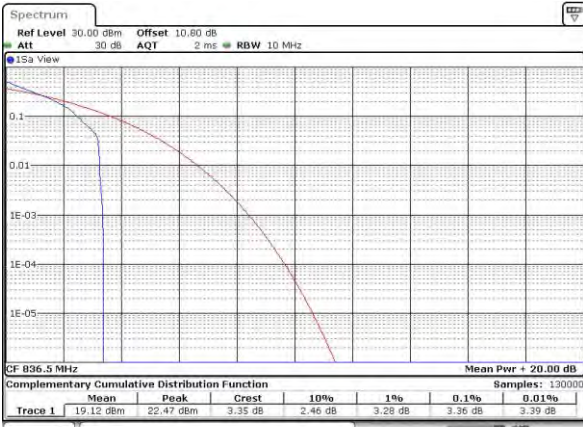

Date: 22.JUL.2019 22:31:21

Middle Channel / Full RB

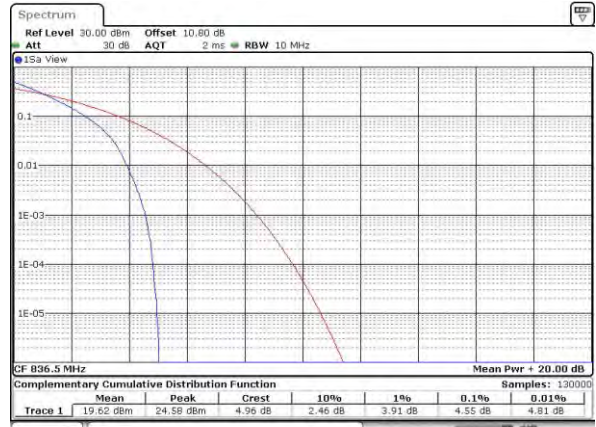

Date: 22.JUL.2019 22:31:31

Highest Channel / 1RB

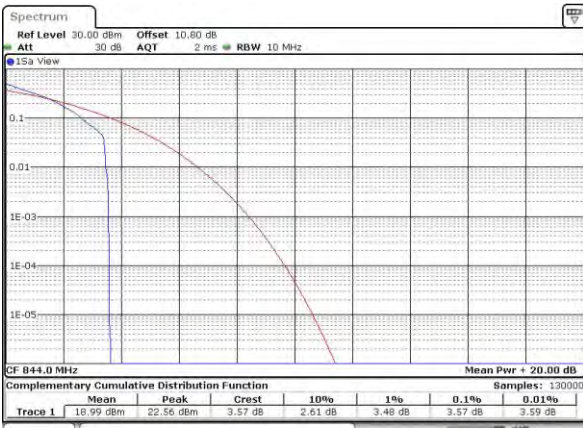

Date: 22.JUL.2019 22:31:42

Highest Channel / Full RB



Date: 22.JUL.2019 22:31:53



LTE Band 5 / 10MHz / 16QAM

Lowest Channel / 1RB

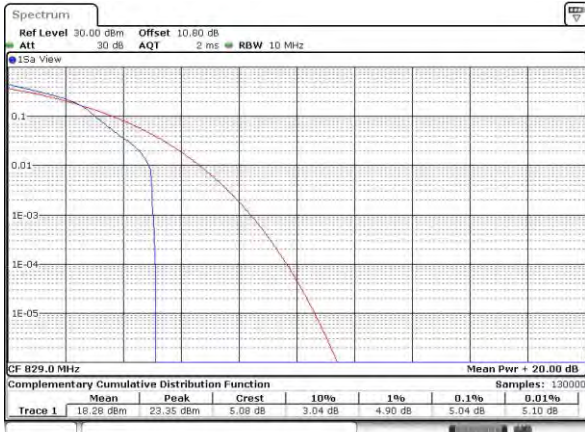

Date: 22.JUL.2019 22:27:26

Lowest Channel / Full RB

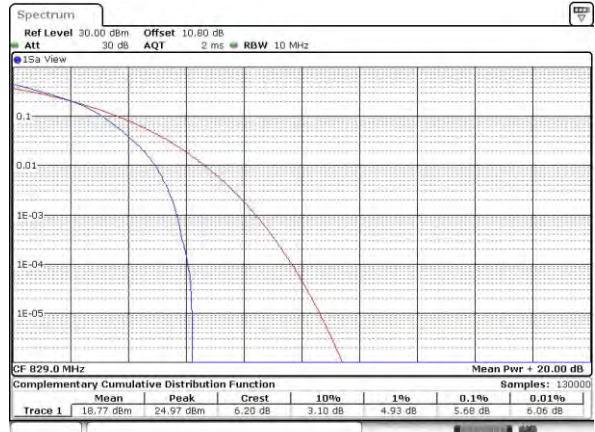

Date: 22.JUL.2019 22:27:37

Middle Channel / 1RB

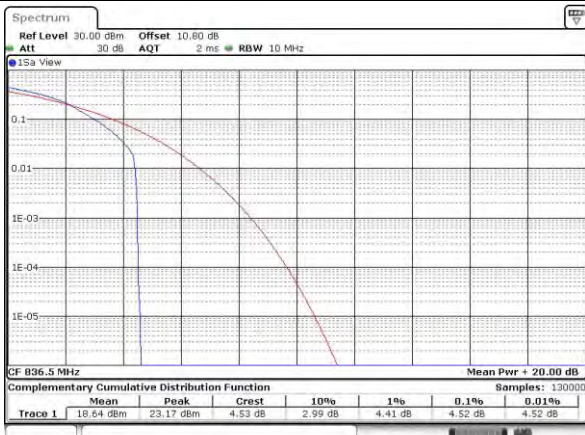

Date: 22.JUL.2019 22:27:51

Middle Channel / Full RB

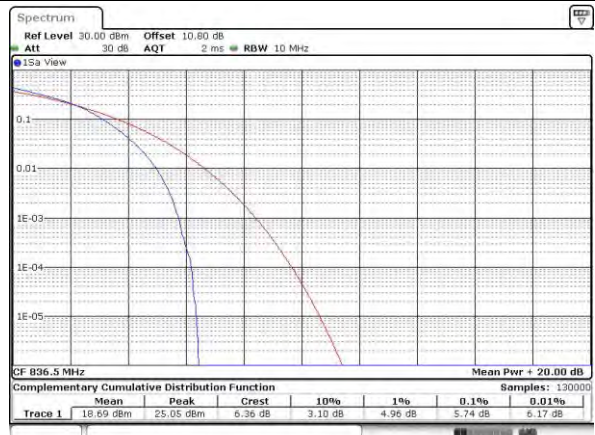

Date: 22.JUL.2019 22:28:51

Highest Channel / 1RB

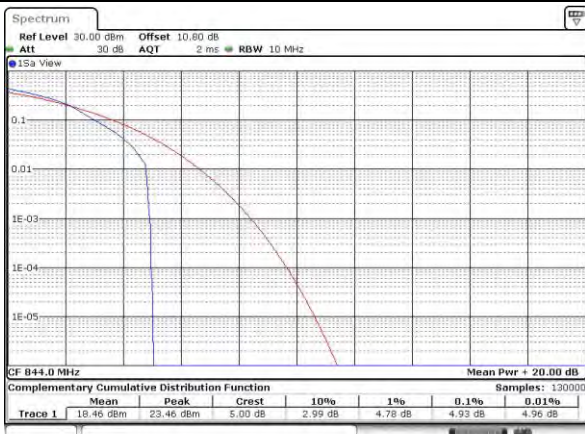

Date: 22.JUL.2019 22:28:04

Highest Channel / Full RB

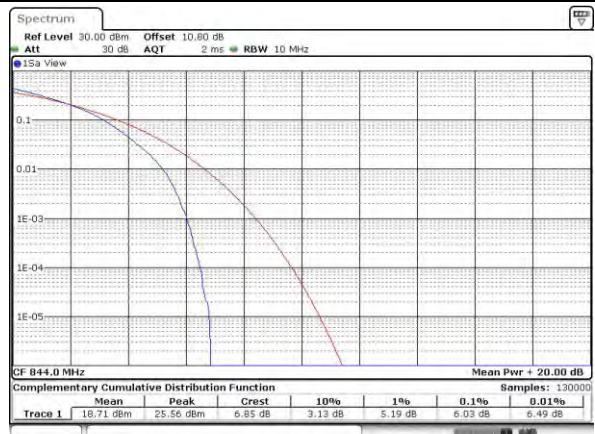

Date: 22.JUL.2019 22:30:49



LTE Band 5 / 10MHz / 64QAM

Lowest Channel / 1RB

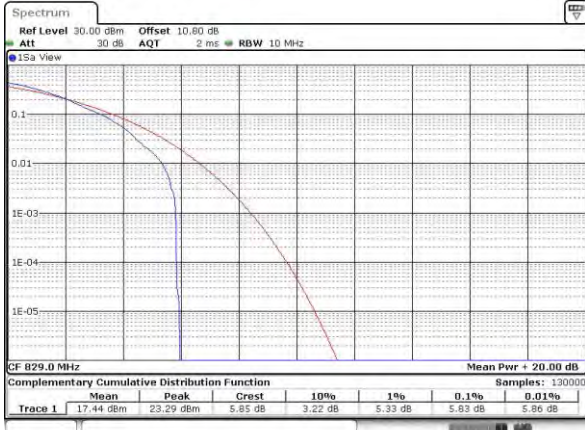

Date: 22.JUL.2019 22:32:04

Lowest Channel / Full RB

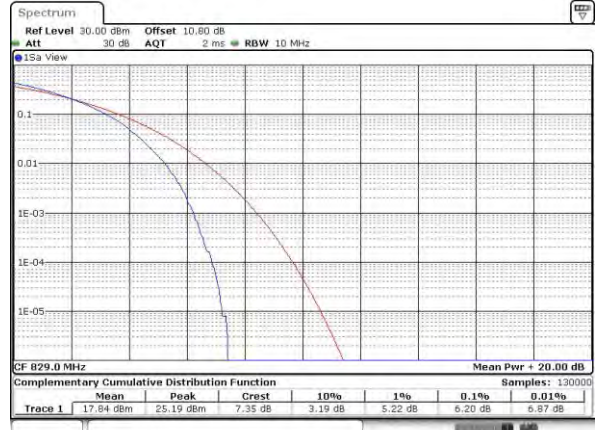

Date: 22.JUL.2019 22:32:15

Middle Channel / 1RB

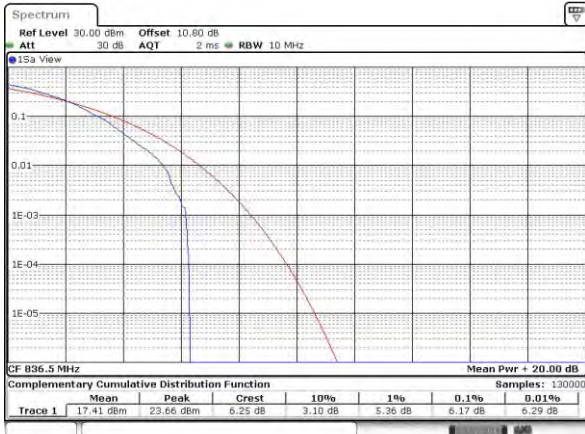

Date: 22.JUL.2019 22:32:25

Middle Channel / Full RB

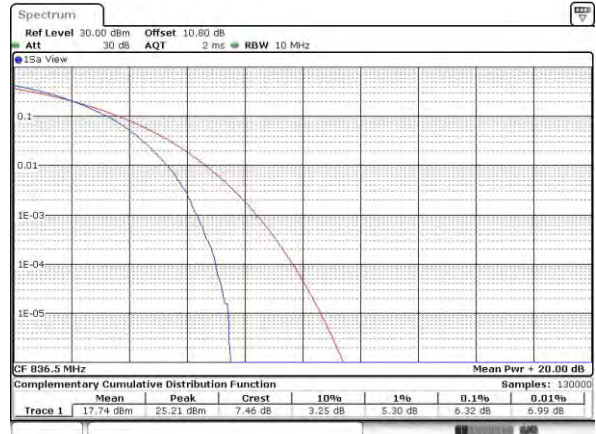

Date: 22.JUL.2019 22:32:35

Highest Channel / 1RB

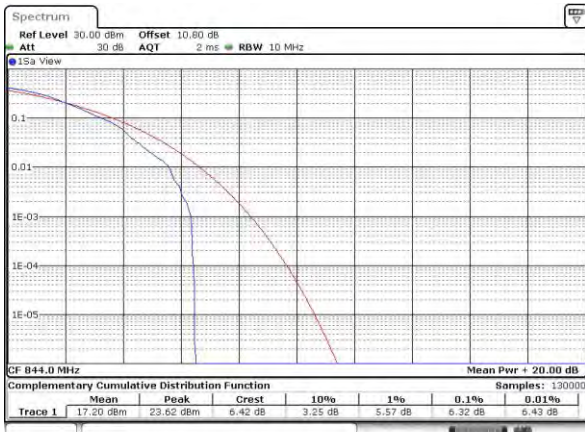

Date: 22.JUL.2019 22:32:46

Highest Channel / Full RB

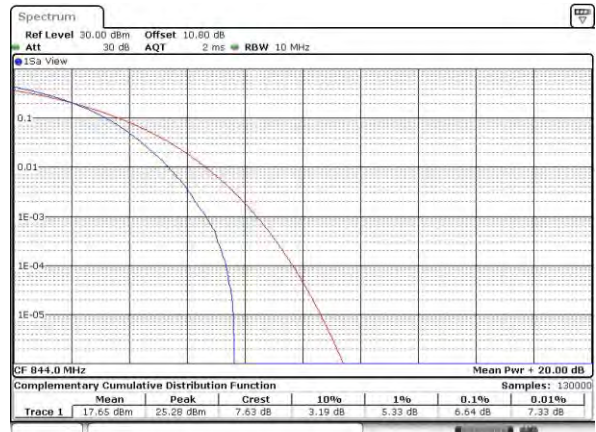

Date: 22.JUL.2019 22:32:57



26dB Bandwidth

Mode	LTE Band 5 : 26dB BW(MHz)											
BW	1.4MHz		3MHz		5MHz		10MHz		15MHz		20MHz	
Mod.	QPSK	16QAM	QPSK	16QAM	QPSK	16QAM	QPSK	16QAM	QPSK	16QAM	QPSK	16QAM
Lowest CH	1.23	1.23	3.03	2.99	4.92	4.85	9.75	9.81	-	-	-	-
Middle CH	1.23	1.21	3.03	3.05	4.92	4.94	9.81	9.99	-	-	-	-
Highest CH	1.23	1.21	3.02	3.02	4.92	4.96	9.87	9.67	-	-	-	-
Mode	LTE Band 5 : 26dB BW(MHz)											
BW	1.4MHz		3MHz		5MHz		10MHz		15MHz		20MHz	
Mod.	64QAM		64QAM		64QAM		64QAM		64QAM		64QAM	
Lowest CH	1.24	-	3.01	-	4.91	-	9.79	-	-	-	-	-
Middle CH	1.22	-	3.03	-	4.87	-	9.83	-	-	-	-	-
Highest CH	1.22	-	3.00	-	4.88	-	9.77	-	-	-	-	-



LTE Band 5

Lowest Channel / 1.4MHz / QPSK

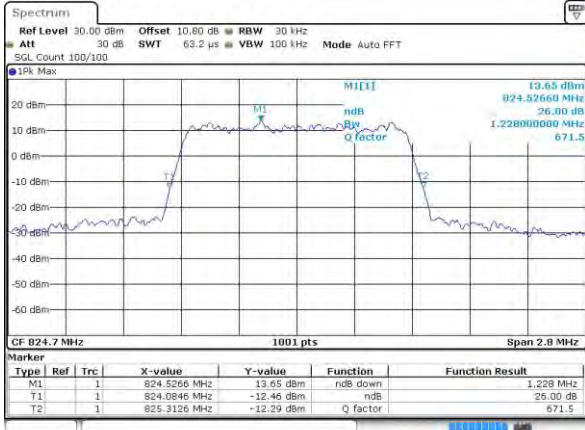

Date: 22 JUL 2019 21:56:10

Lowest Channel / 1.4MHz / 16QAM

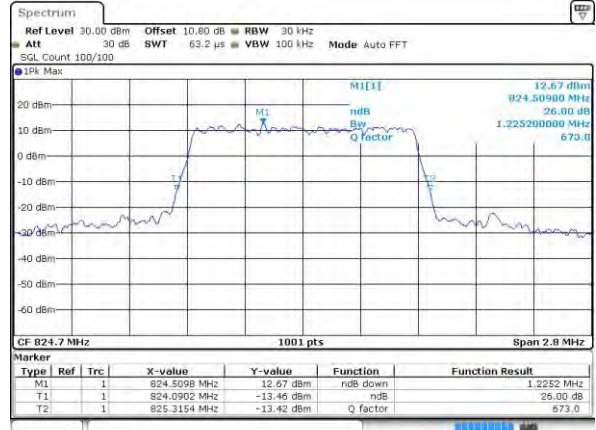

Date: 22 JUL 2019 21:55:58

Middle Channel / 1.4MHz / QPSK

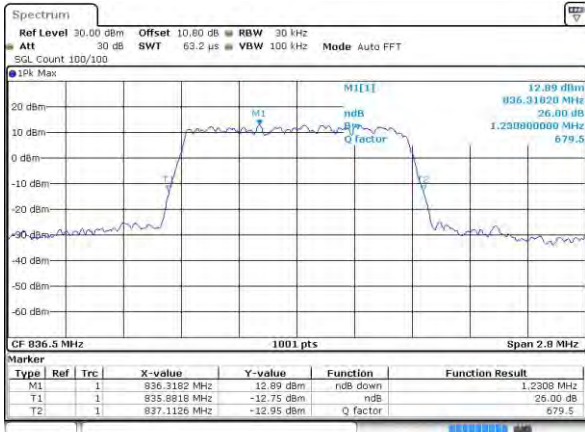

Date: 22 JUL 2019 22:05:03

Middle Channel / 1.4MHz / 16QAM

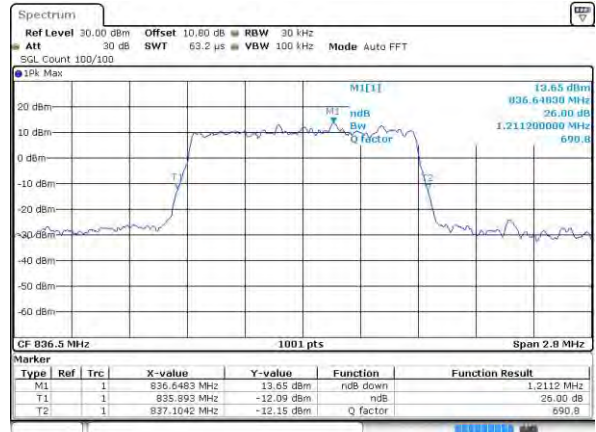

Date: 22 JUL 2019 22:05:15

Highest Channel / 1.4MHz / QPSK

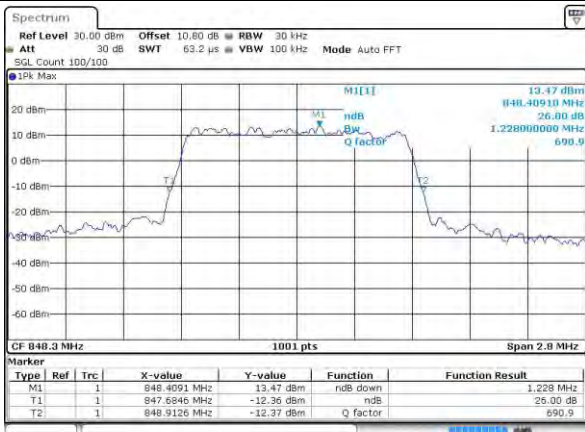

Date: 22 JUL 2019 22:07:23

Highest Channel / 1.4MHz / 16QAM

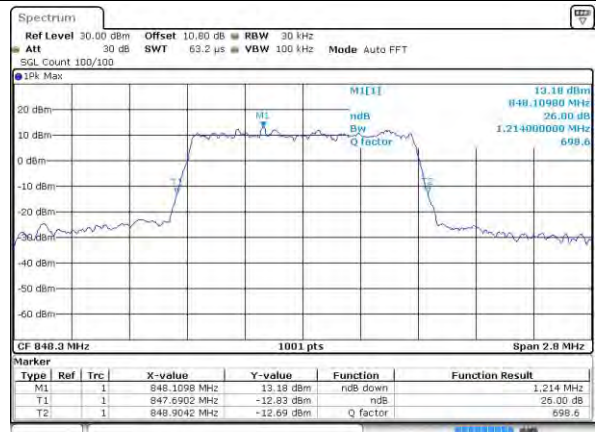

Date: 22 JUL 2019 22:07:35



LTE Band 5

Lowest Channel / 3MHz / QPSK

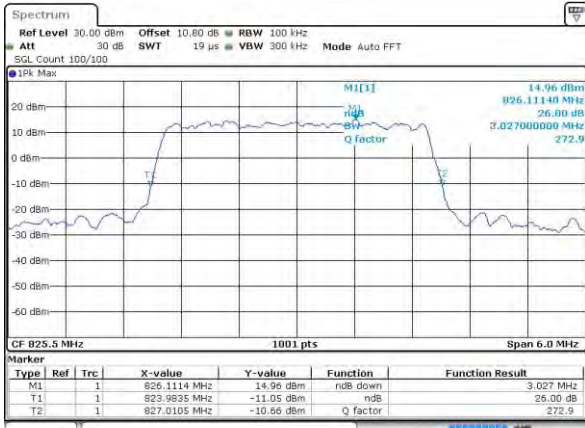

Lowest Channel / 3MHz / 16QAM

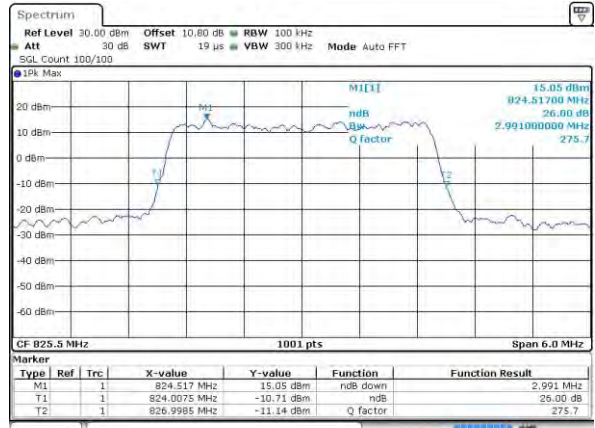

Middle Channel / 3MHz / QPSK

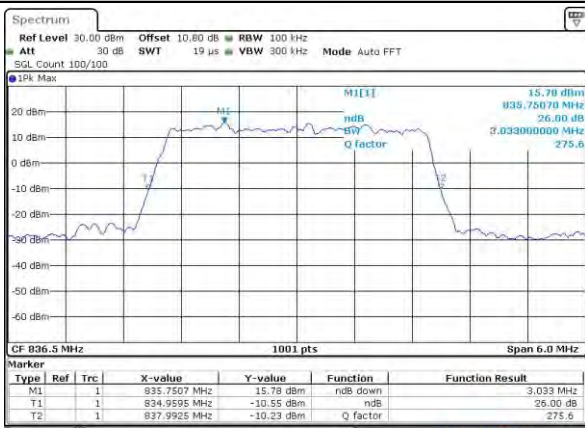

Middle Channel / 3MHz / 16QAM

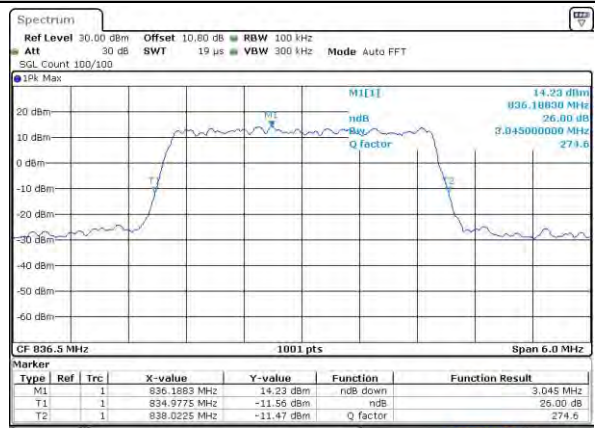

Highest Channel / 3MHz / QPSK

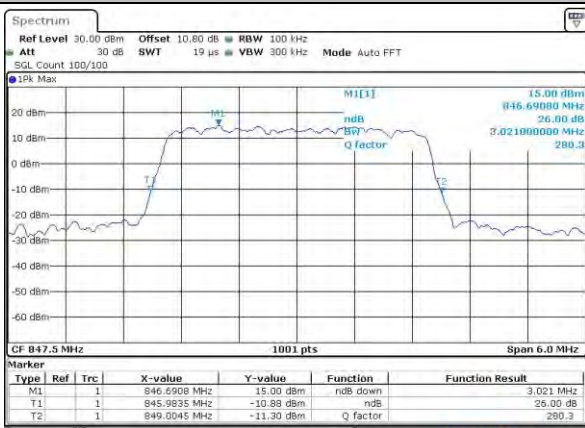

Highest Channel / 3MHz / 16QAM

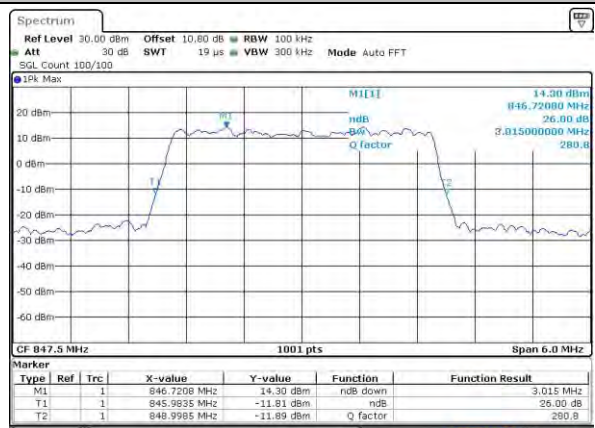



LTE Band 5

Lowest Channel / 5MHz / QPSK

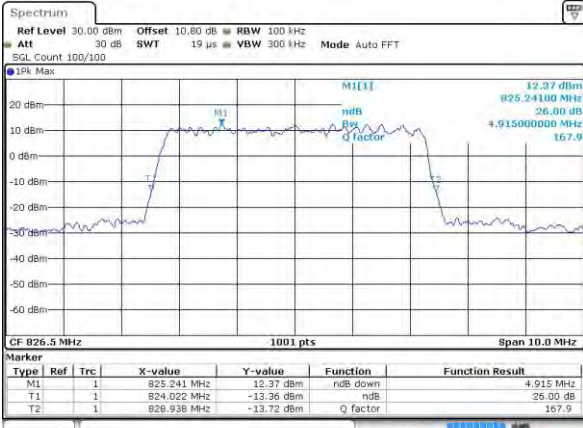

Date: 22 JUL 2019 20:47:52

Lowest Channel / 5MHz / 16QAM

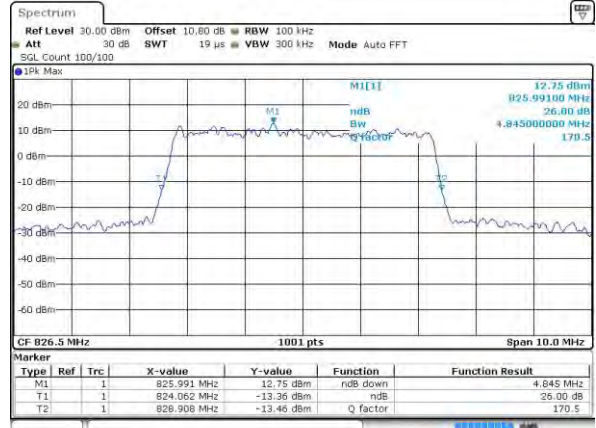

Date: 22 JUL 2019 20:48:04

Middle Channel / 5MHz / QPSK

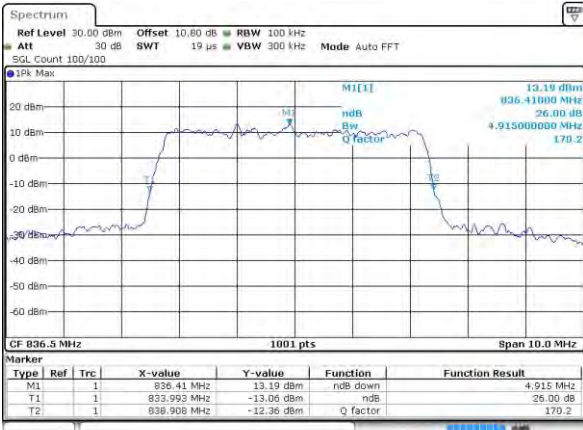

Date: 22 JUL 2019 20:56:57

Middle Channel / 5MHz / 16QAM

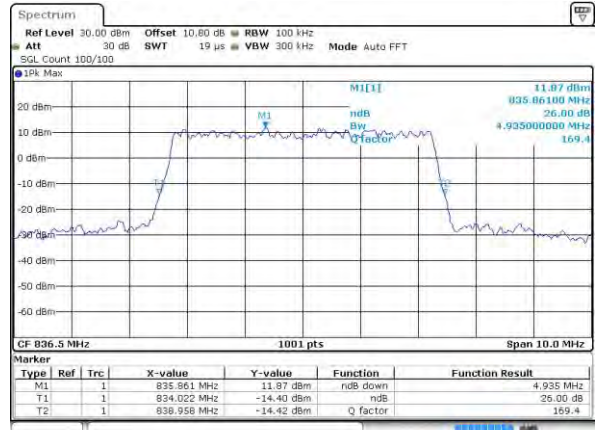

Date: 22 JUL 2019 20:57:06

Highest Channel / 5MHz / QPSK

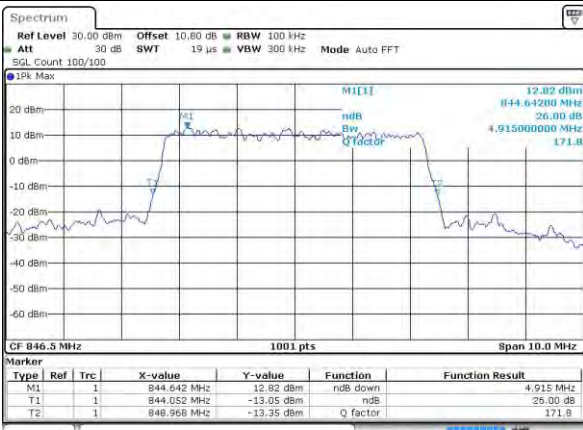

Date: 22 JUL 2019 20:58:17

Highest Channel / 5MHz / 16QAM

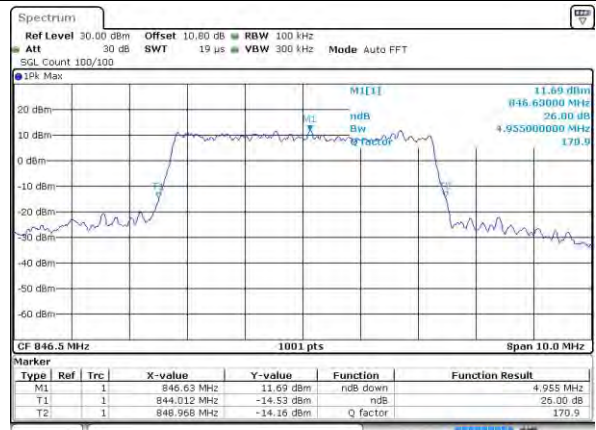

Date: 22 JUL 2019 20:59:29



LTE Band 5

Lowest Channel / 10MHz / QPSK

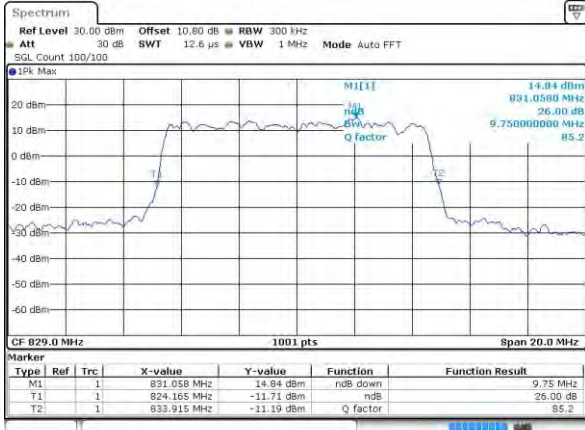

Lowest Channel / 10MHz / 16QAM

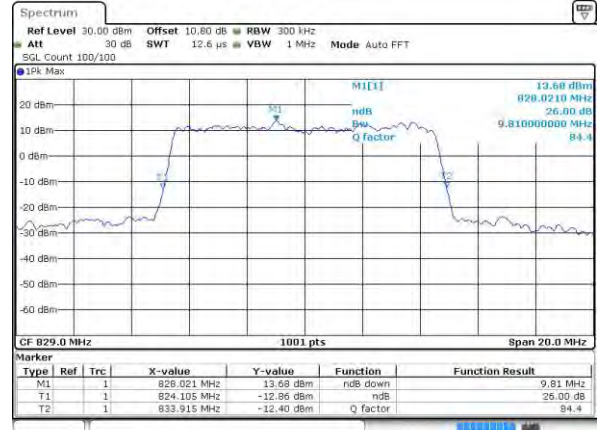

Middle Channel / 10MHz / QPSK

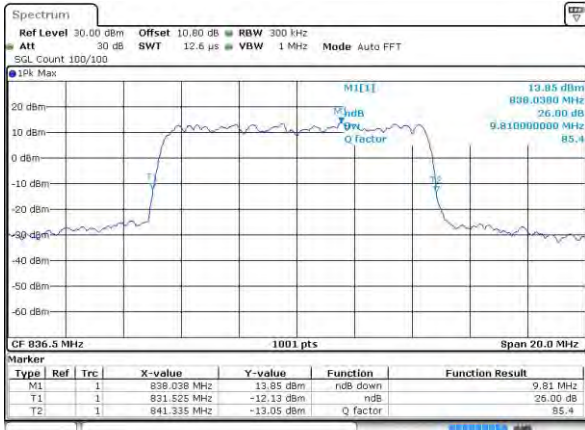

Middle Channel / 10MHz / 16QAM

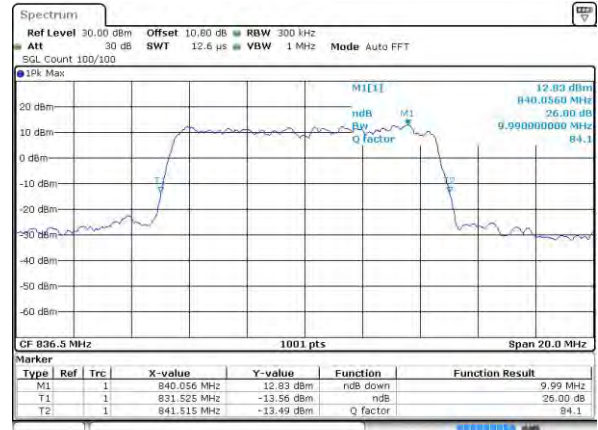

Highest Channel / 10MHz / QPSK

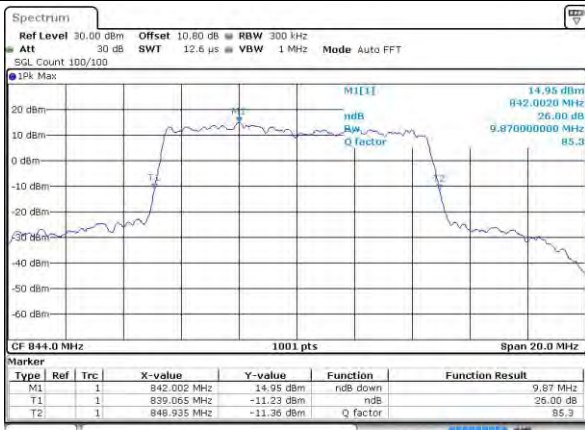

Highest Channel / 10MHz / 16QAM

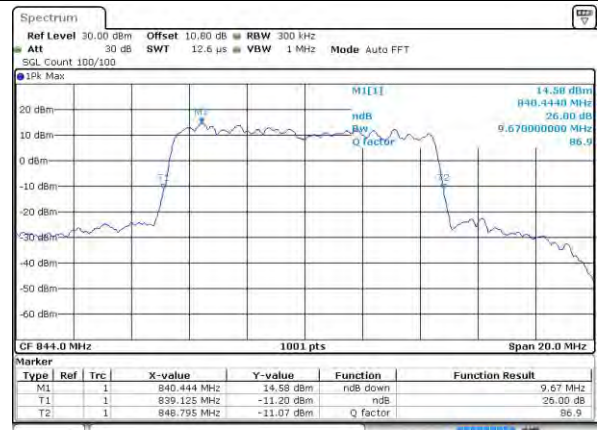



LTE Band 5

Lowest Channel / 1.4MHz / 64QAM

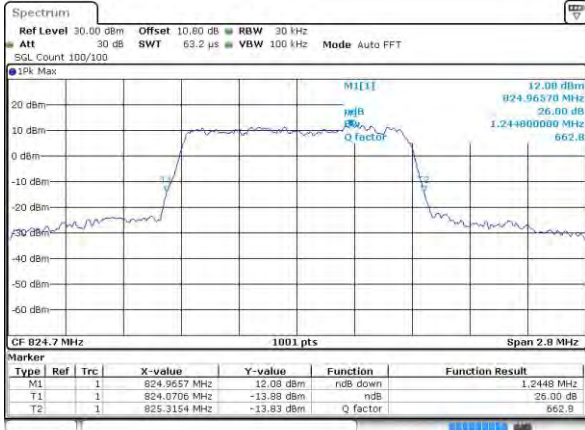

Date: 22 JUL 2019 22:16:17

Lowest Channel / 3MHz / 64QAM

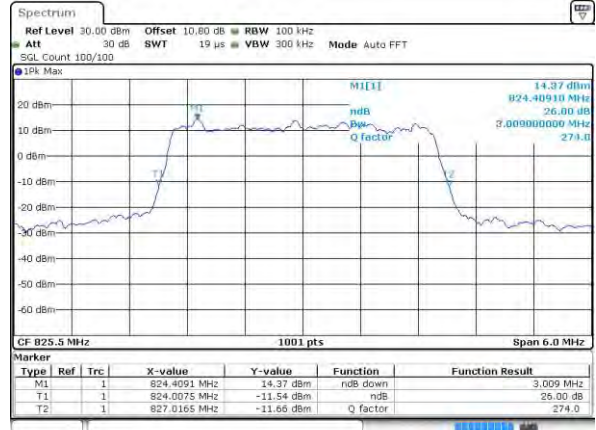

Date: 22 JUL 2019 20:37:23

Middle Channel / 1.4MHz / 64QAM

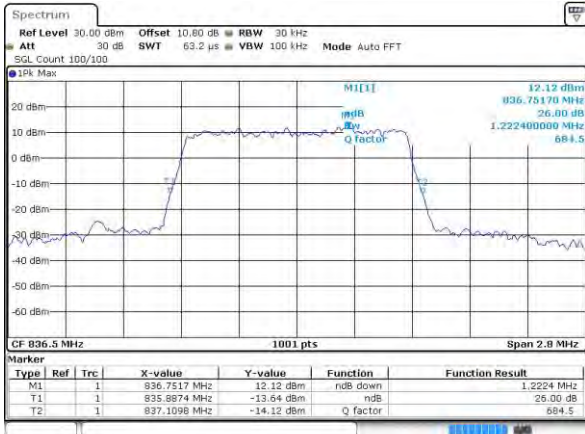

Date: 22 JUL 2019 22:20:49

Middle Channel / 3MHz / 64QAM

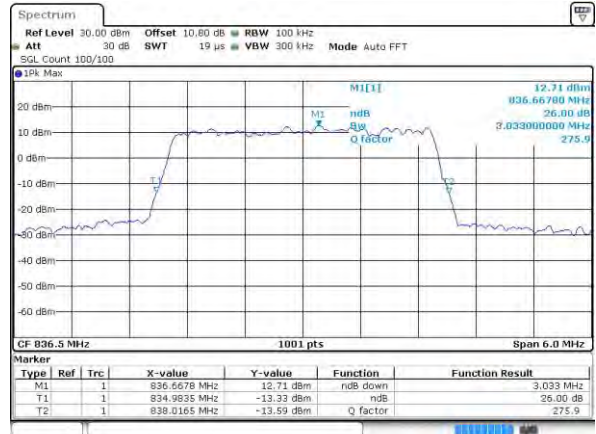

Date: 22 JUL 2019 20:41:56

Highest Channel / 1.4MHz / 64QAM

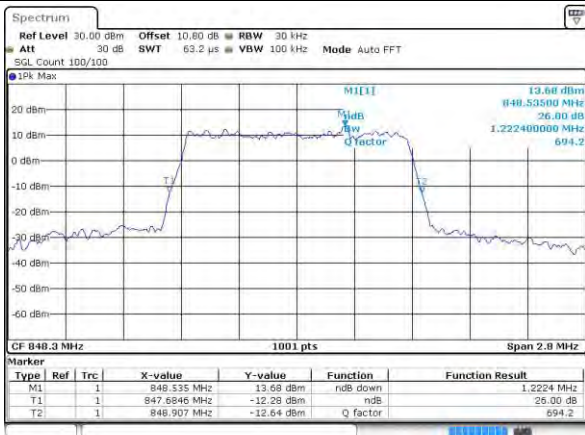

Date: 22 JUL 2019 22:21:59

Highest Channel / 3MHz / 64QAM

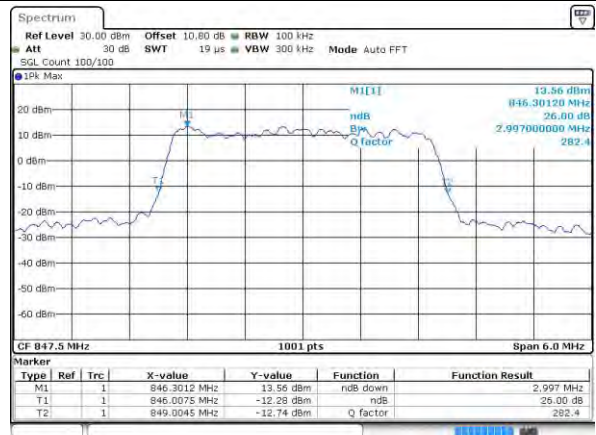

Date: 22 JUL 2019 20:43:06



LTE Band 5

Lowest Channel / 5MHz / 64QAM

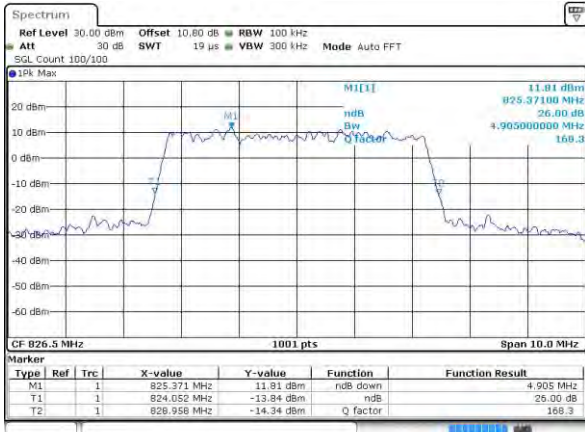

Date: 22 JUL 2019 21:08:11

Lowest Channel / 10MHz / 64QAM

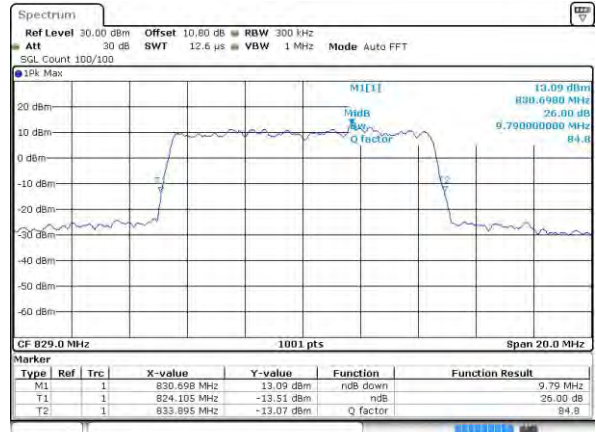

Date: 22 JUL 2019 21:44:06

Middle Channel / 5MHz / 64QAM

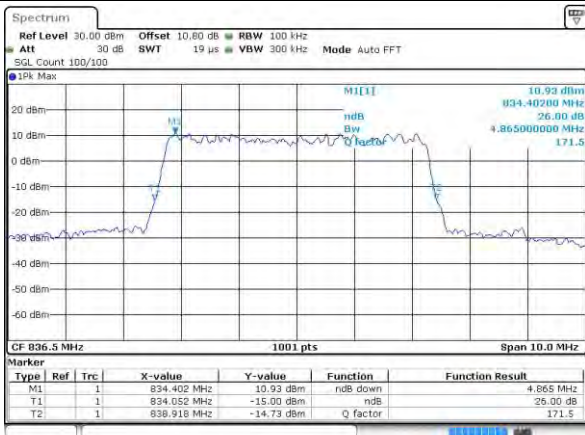

Date: 22 JUL 2019 21:12:43

Middle Channel / 10MHz / 64QAM

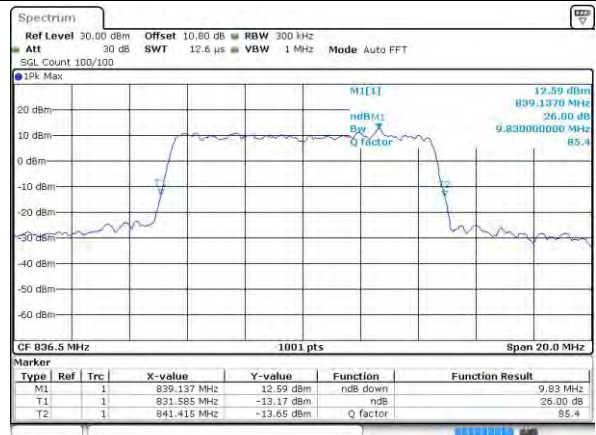

Date: 22 JUL 2019 21:48:38

Highest Channel / 5MHz / 64QAM

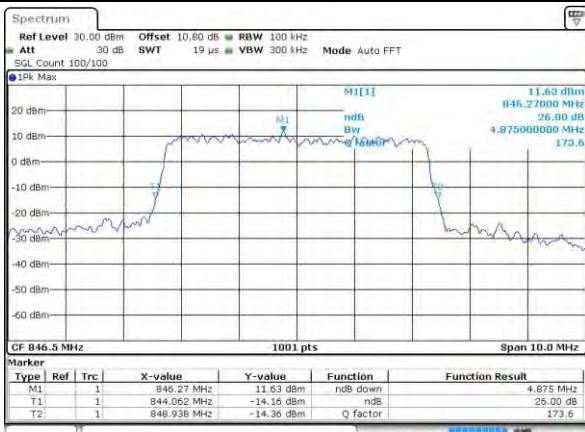

Date: 22 JUL 2019 21:13:53

Highest Channel / 10MHz / 64QAM

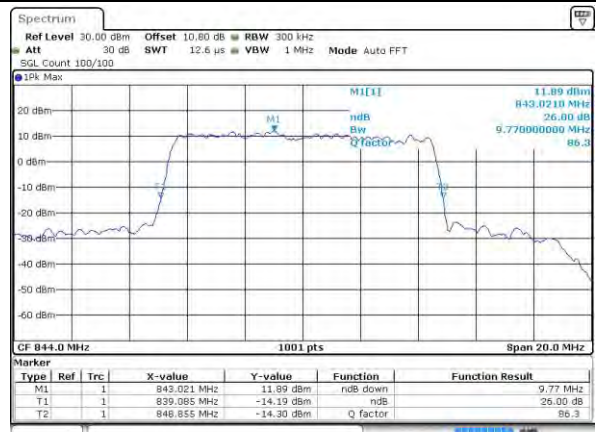

Date: 22 JUL 2019 21:48:48



Occupied Bandwidth

Mode	LTE Band 5 : 99%OBW(MHz)											
BW	1.4MHz		3MHz		5MHz		10MHz		15MHz		20MHz	
Mod.	QPSK	16QAM	QPSK	16QAM	QPSK	16QAM	QPSK	16QAM	QPSK	16QAM	QPSK	16QAM
Lowest CH	1.09	1.09	2.72	2.73	4.51	4.50	9.03	9.07	-	-	-	-
Middle CH	1.09	1.09	2.70	2.71	4.49	4.51	9.07	9.03	-	-	-	-
Highest CH	1.09	1.09	2.72	2.72	4.52	4.50	9.01	8.95	-	-	-	-
Mode	LTE Band 5 : 99%OBW(MHz)											
BW	1.4MHz		3MHz		5MHz		10MHz		15MHz		20MHz	
Mod.	64QAM		64QAM		64QAM		64QAM		64QAM		64QAM	
Lowest CH	1.09	-	2.73	-	4.52	-	9.03	-	-	-	-	-
Middle CH	1.09	-	2.72	-	4.53	-	9.01	-	-	-	-	-
Highest CH	1.09	-	2.73	-	4.47	-	9.03	-	-	-	-	-



LTE Band 5

Lowest Channel / 1.4MHz / QPSK

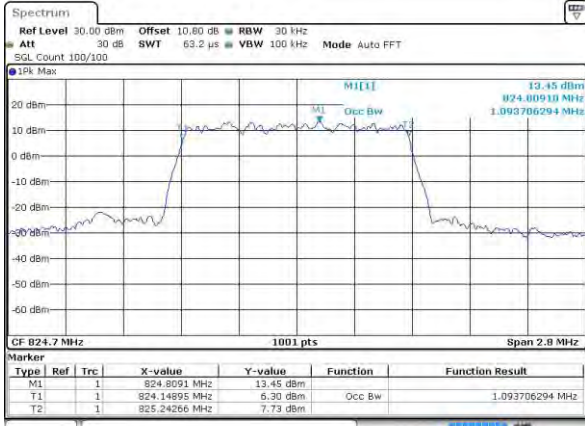

Lowest Channel / 1.4MHz / 16QAM

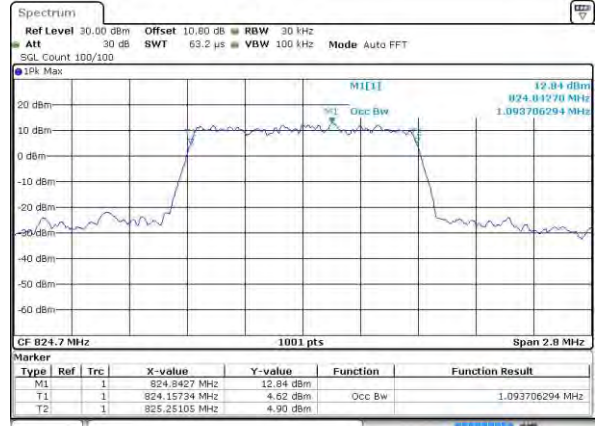

Middle Channel / 1.4MHz / QPSK

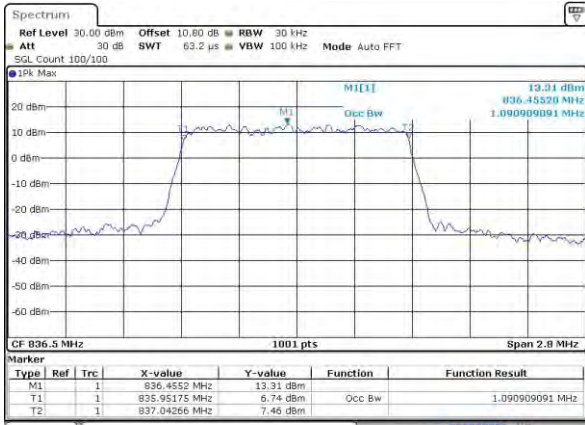

Middle Channel / 1.4MHz / 16QAM

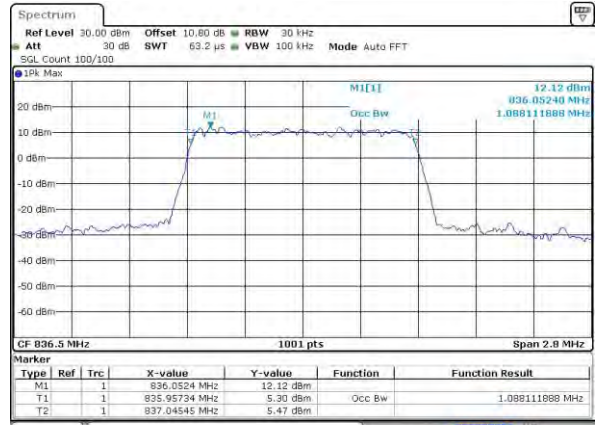

Highest Channel / 1.4MHz / QPSK

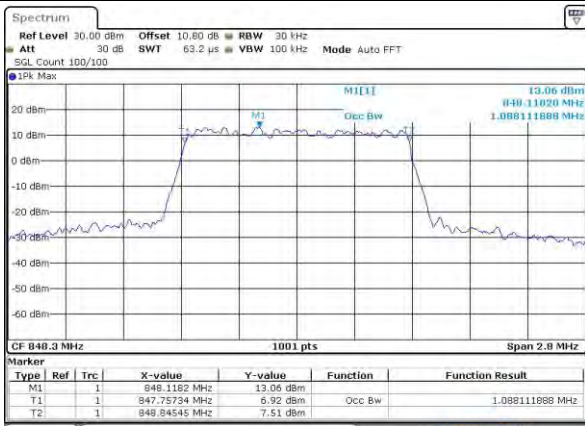

Highest Channel / 1.4MHz / 16QAM

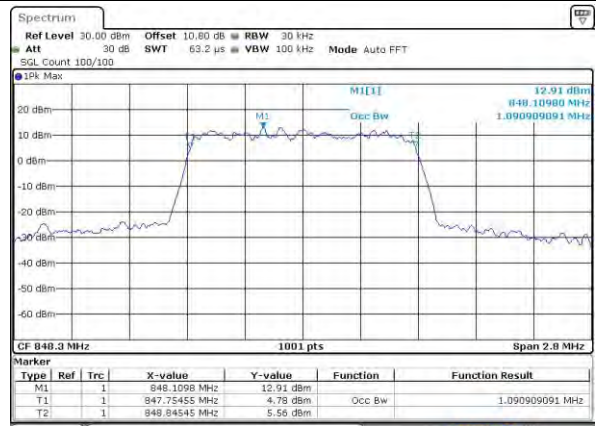



LTE Band 5

Lowest Channel / 3MHz / QPSK

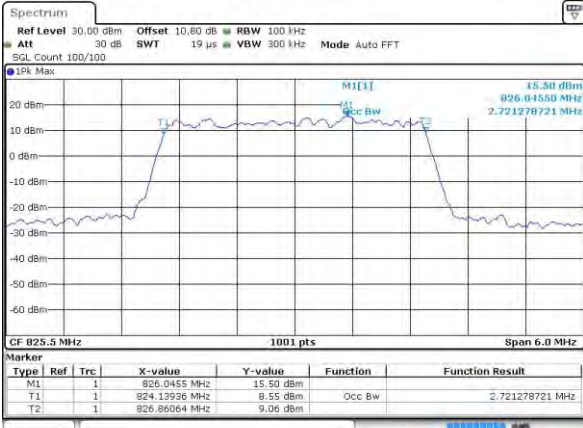

Lowest Channel / 3MHz / 16QAM

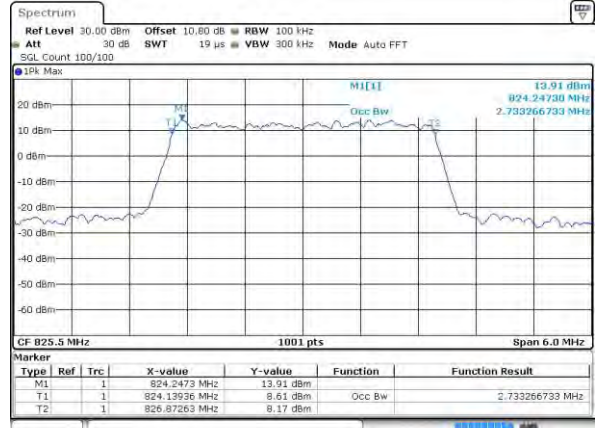

Middle Channel / 3MHz / QPSK

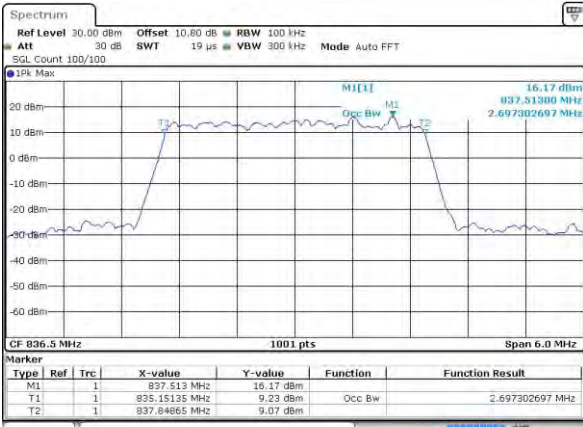

Middle Channel / 3MHz / 16QAM

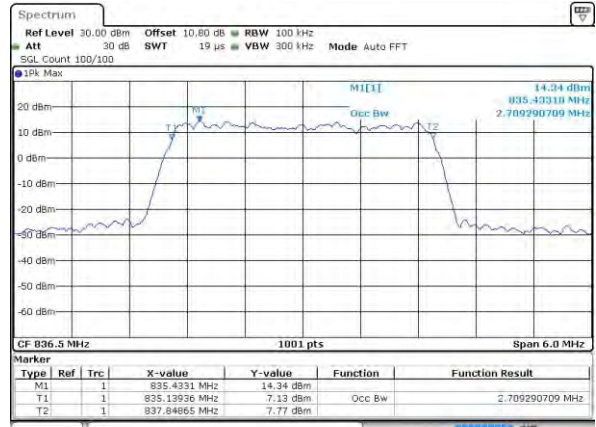

Highest Channel / 3MHz / QPSK

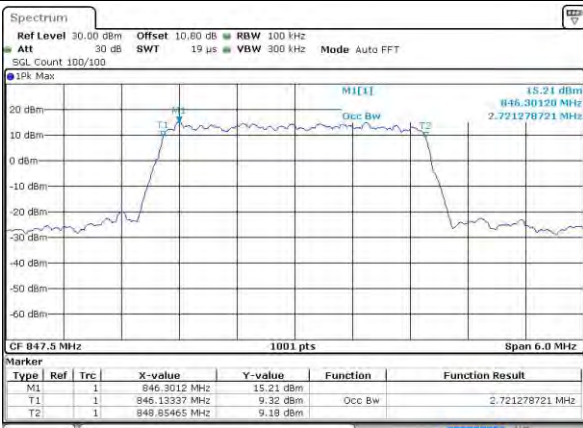

Highest Channel / 3MHz / 16QAM

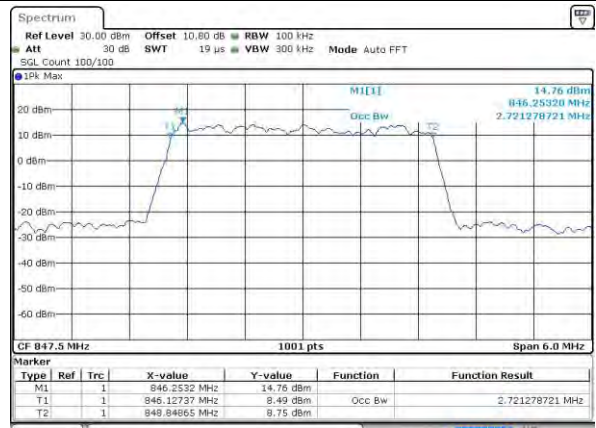



LTE Band 5

Lowest Channel / 5MHz / QPSK

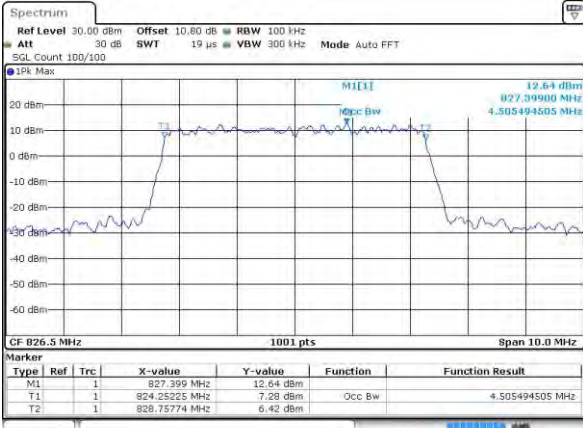

Lowest Channel / 5MHz / 16QAM

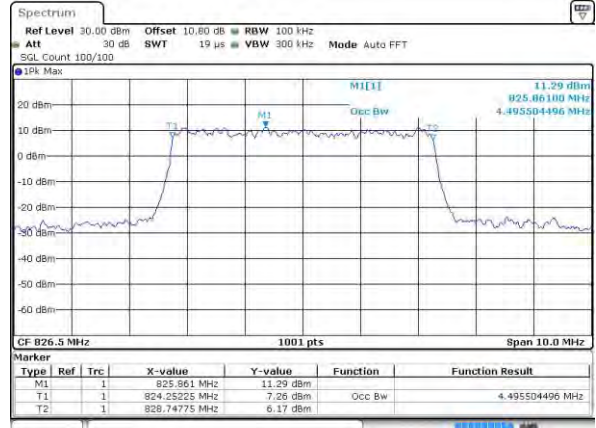

Middle Channel / 5MHz / QPSK

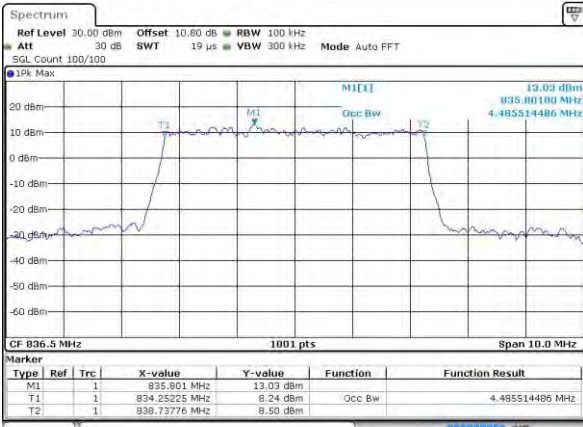

Middle Channel / 5MHz / 16QAM

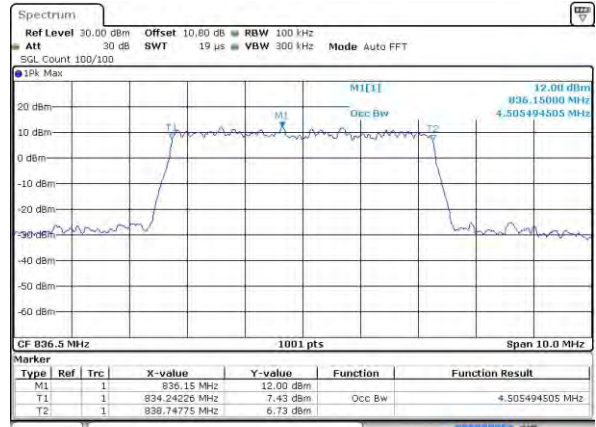

Highest Channel / 5MHz / QPSK

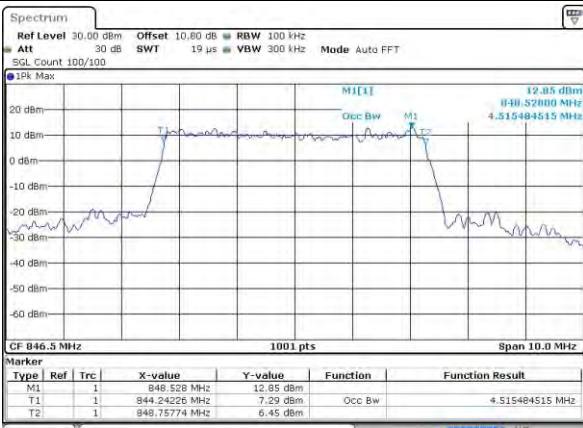

Highest Channel / 5MHz / 16QAM

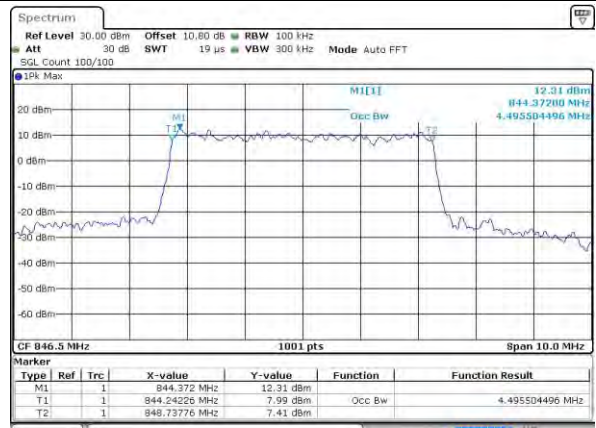



LTE Band 5

Lowest Channel / 10MHz / QPSK

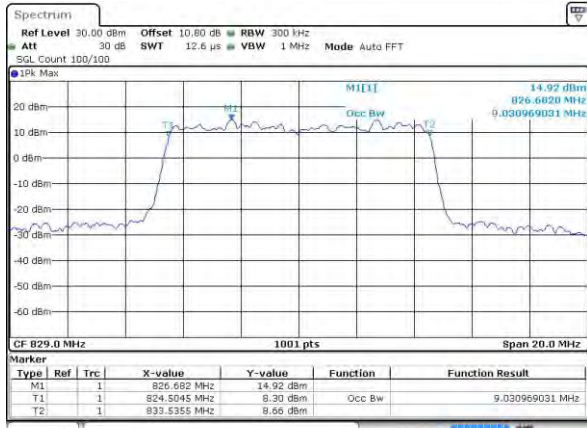

Lowest Channel / 10MHz / 16QAM

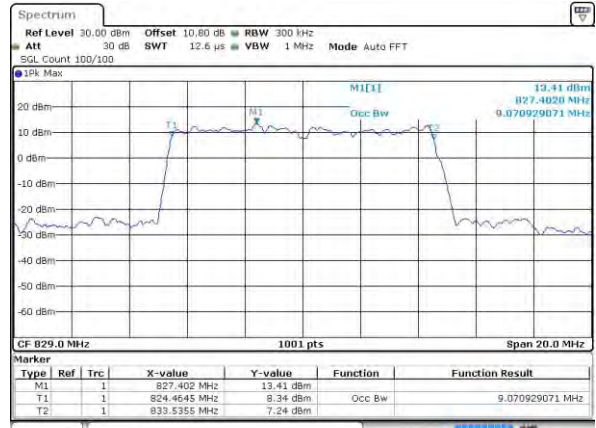

Middle Channel / 10MHz / QPSK

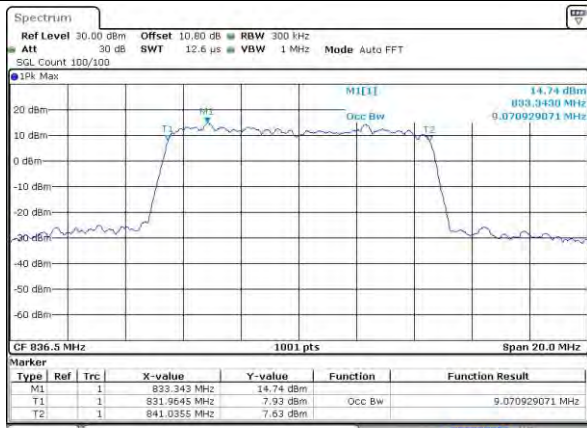

Middle Channel / 10MHz / 16QAM

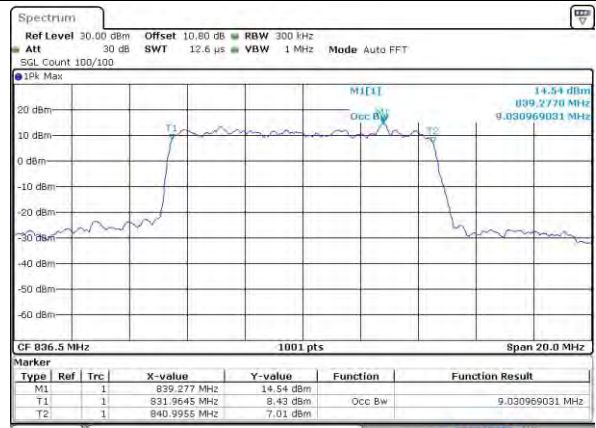

Highest Channel / 10MHz / QPSK

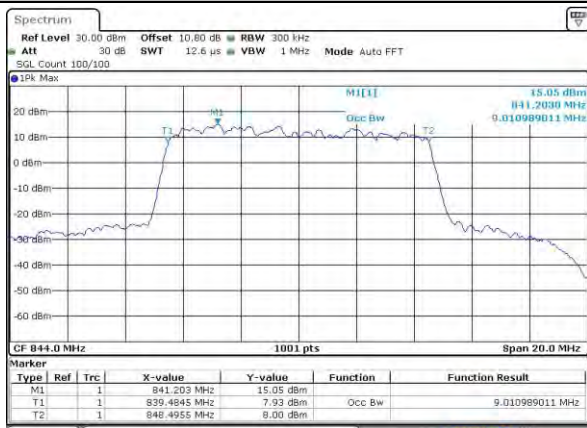

Highest Channel / 10MHz / 16QAM

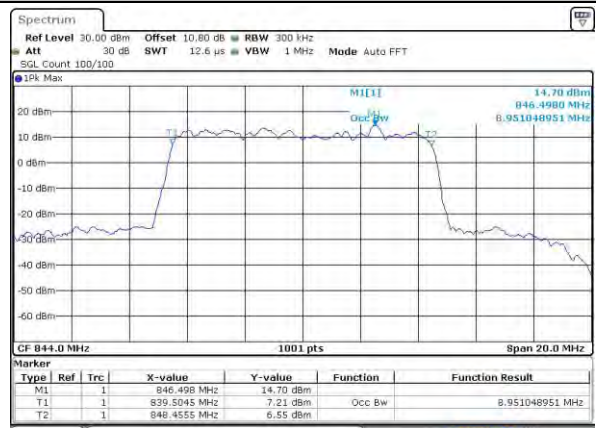



LTE Band 5

Lowest Channel / 1.4MHz / 64QAM

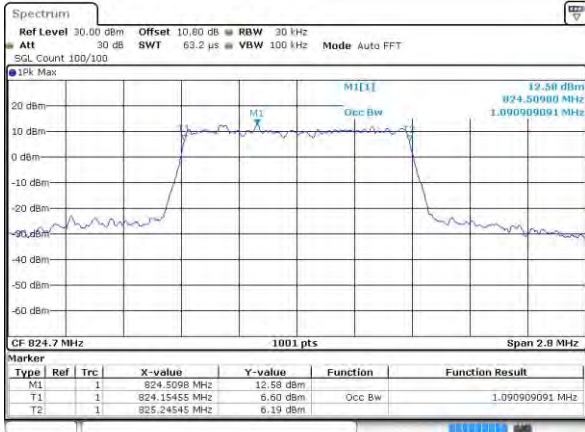

Date: 22 JUL 2019 22:16:05

Lowest Channel / 3MHz / 64QAM

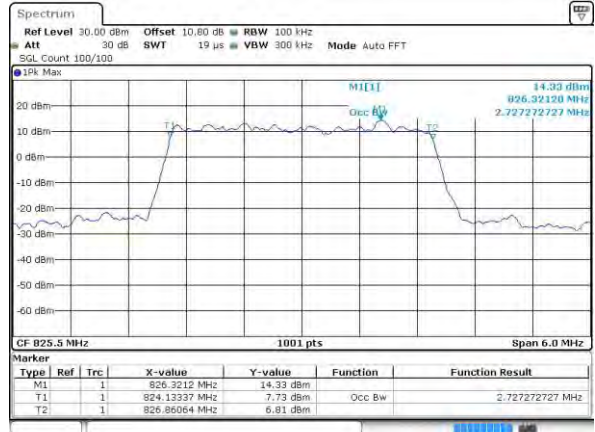

Date: 22 JUL 2019 20:37:11

Middle Channel / 1.4MHz / 64QAM

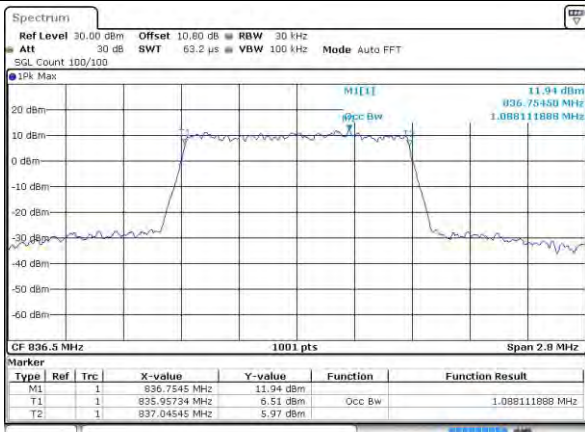

Date: 22 JUL 2019 22:20:38

Middle Channel / 3MHz / 64QAM

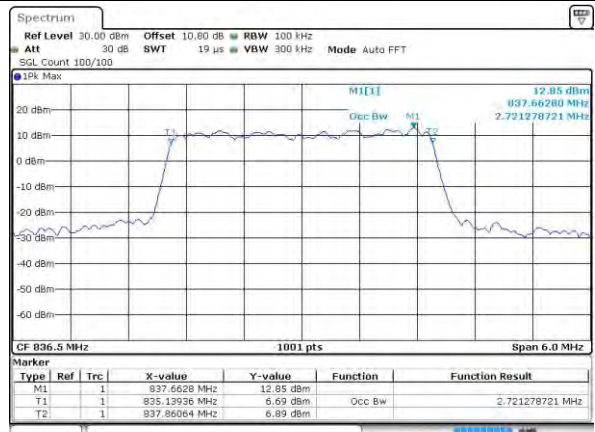

Date: 22 JUL 2019 20:41:44

Highest Channel / 1.4MHz / 64QAM

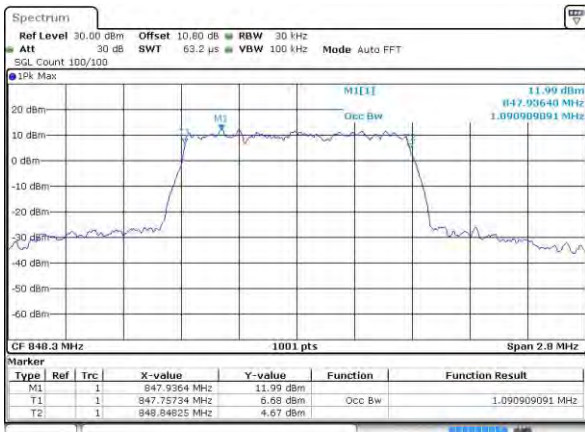

Date: 22 JUL 2019 22:21:47

Highest Channel / 3MHz / 64QAM

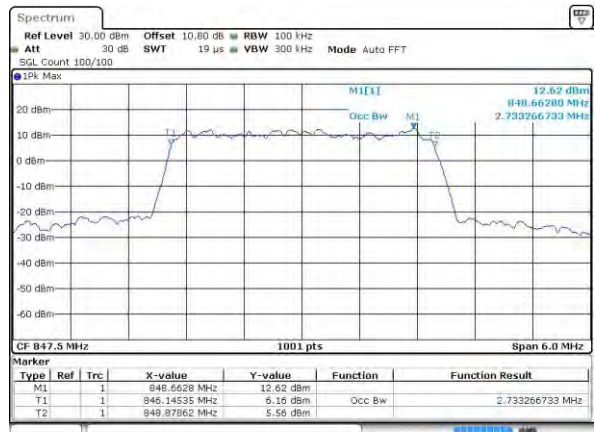

Date: 22 JUL 2019 20:42:54



LTE Band 5

Lowest Channel / 5MHz / 64QAM

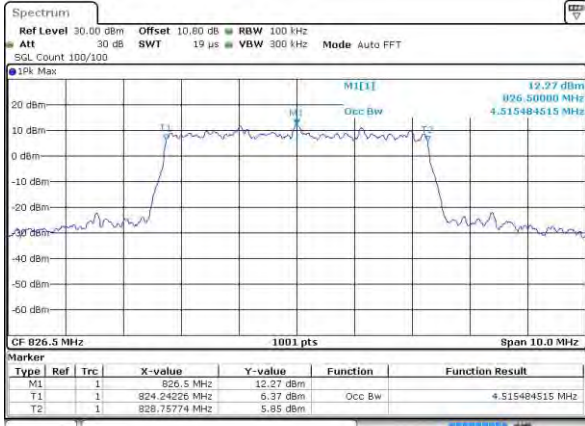

Date: 22 JUL 2019 21:07:59

Lowest Channel / 10MHz / 64QAM

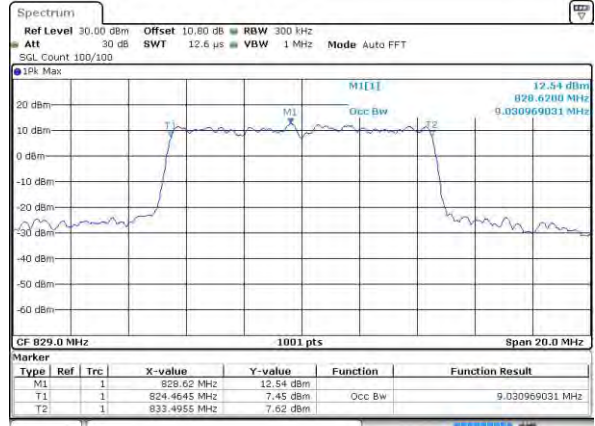

Date: 22 JUL 2019 21:43:54

Middle Channel / 5MHz / 64QAM

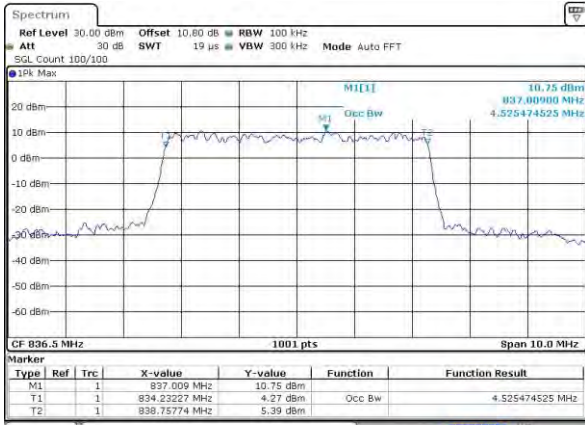

Date: 22 JUL 2019 21:12:31

Middle Channel / 10MHz / 64QAM

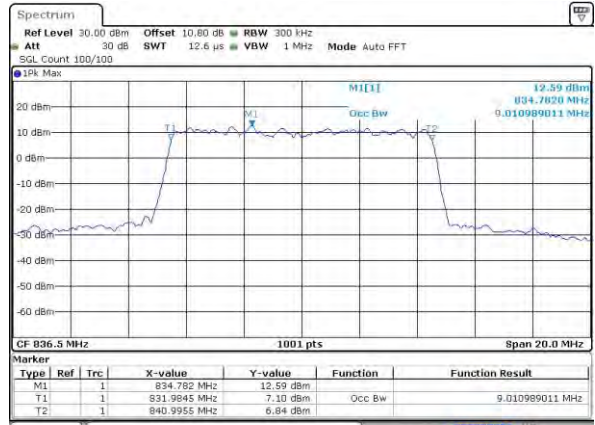

Date: 22 JUL 2019 21:48:26

Highest Channel / 5MHz / 64QAM

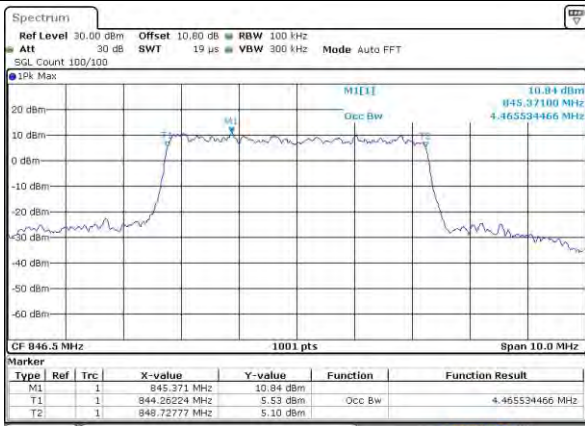

Date: 22 JUL 2019 21:13:41

Highest Channel / 10MHz / 64QAM

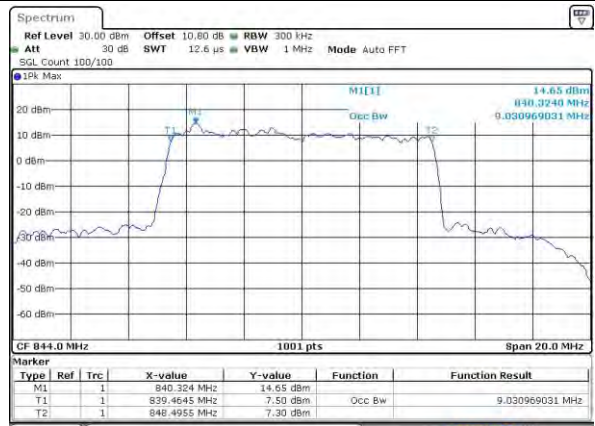

Date: 22 JUL 2019 21:49:36



Conducted Band Edge

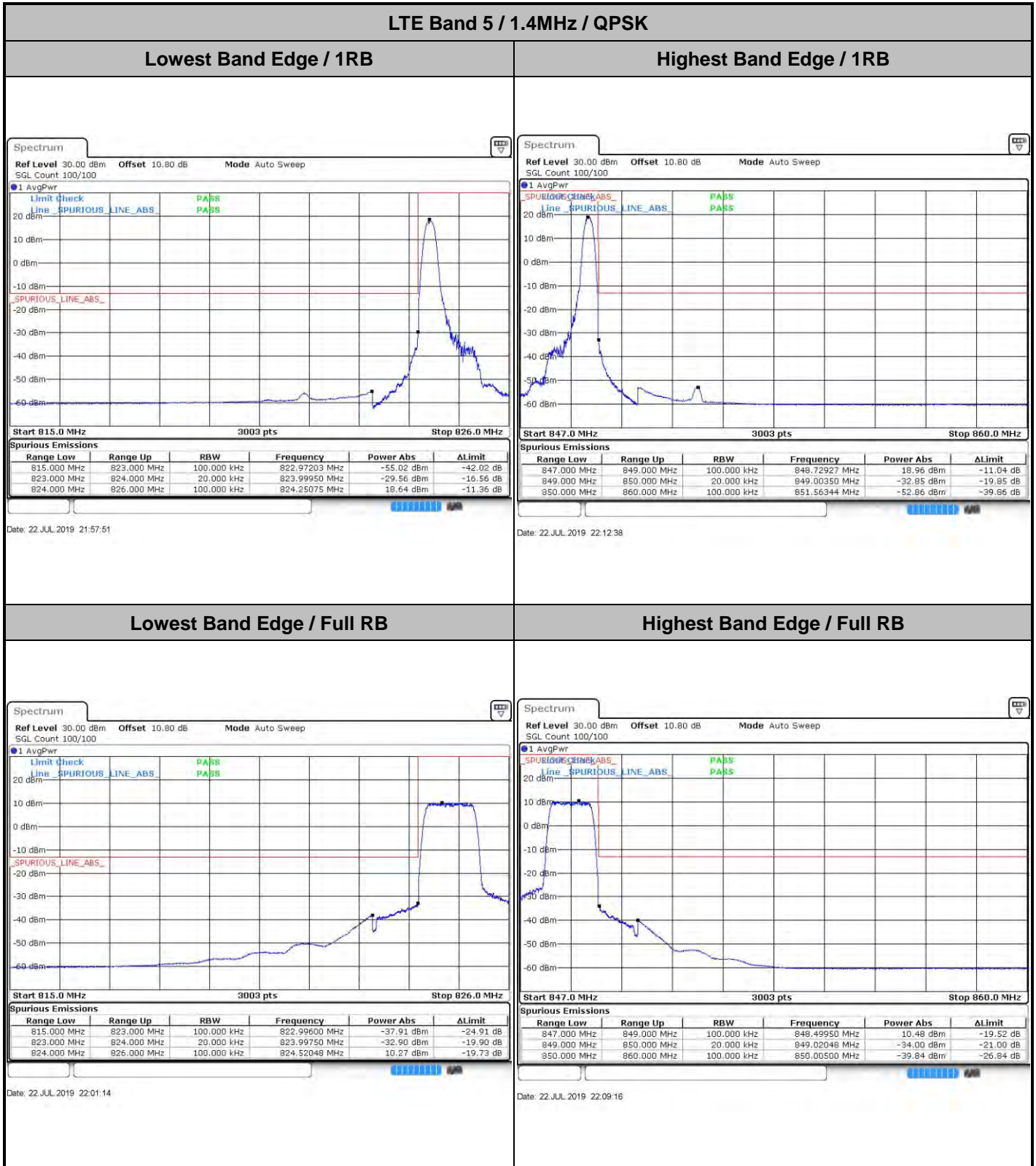



LTE Band 5 / 1.4MHz / 16QAM

Lowest Band Edge / 1 RB

Highest Band Edge / 1 RB



Date: 22 JUL 2019 21:58:32

Date: 22 JUL 2019 22:14:19

Lowest Band Edge / Full RB

Highest Band Edge / Full RB



Date: 22 JUL 2019 22:02:55

Date: 22 JUL 2019 22:10:57



LTE Band 5 / 1.4MHz / 64QAM

Lowest Band Edge / 1 RB

Highest Band Edge / 1 RB



Date: 22 JUL 2019 22:17:58



Date: 22 JUL 2019 22:25:21

Lowest Band Edge / Full RB

Highest Band Edge / Full RB



Date: 22 JUL 2019 22:19:39



Date: 22 JUL 2019 22:23:40



LTE Band 5 / 3MHz / QPSK

Lowest Band Edge / 1RB

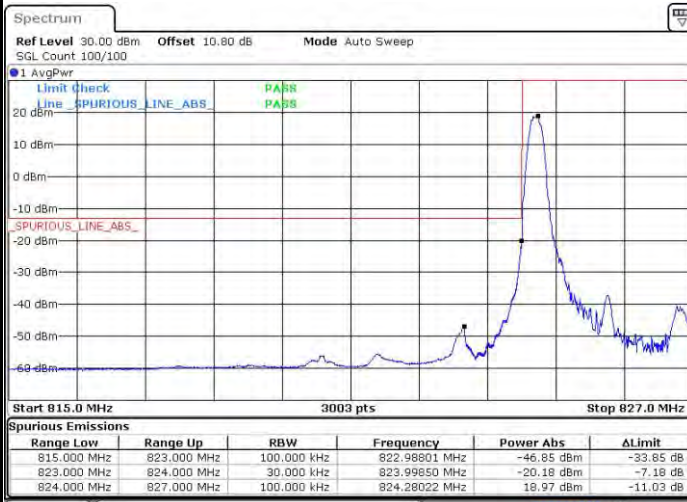

Date: 22 JUL 2019 20:18:57

Highest Band Edge / 1 RB

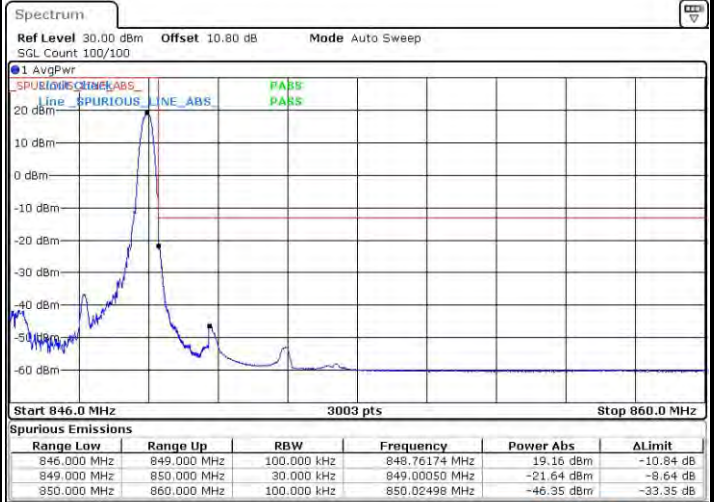

Date: 22 JUL 2019 20:30:22

Lowest Band Edge / Full RB



Date: 22 JUL 2019 20:22:19

Highest Band Edge / Full RB



Date: 22 JUL 2019 20:33:44



LTE Band 5 / 3MHz / 16QAM

Lowest Band Edge / 1 RB

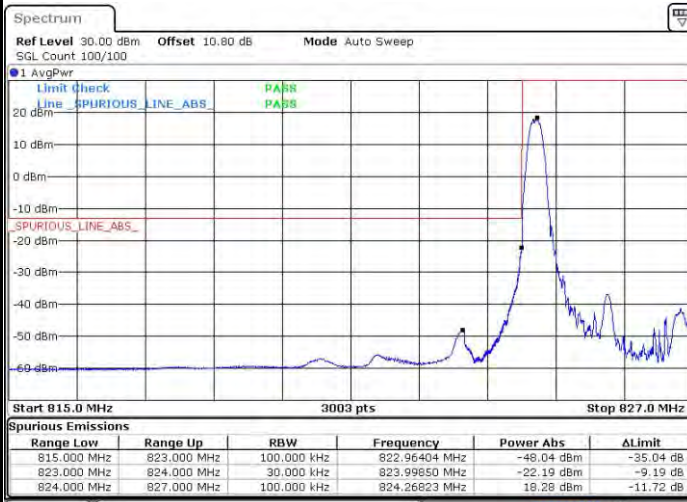

Date: 22 JUL 2019 20:20:38

Highest Band Edge / 1 RB



Date: 22 JUL 2019 20:32:03

Lowest Band Edge / Full RB



Date: 22 JUL 2019 20:24:01

Highest Band Edge / Full RB



Date: 22 JUL 2019 20:35:25



LTE Band 5 / 3MHz / 64QAM

Lowest Band Edge / 1 RB

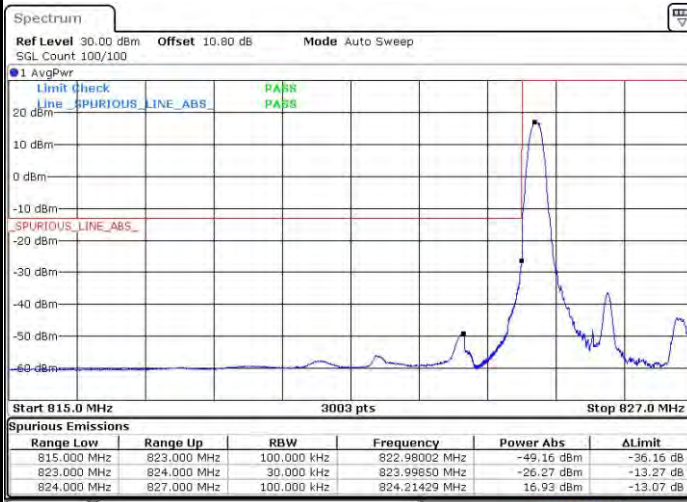

Date: 22 JUL 2019 20:39:04

Highest Band Edge / 1 RB

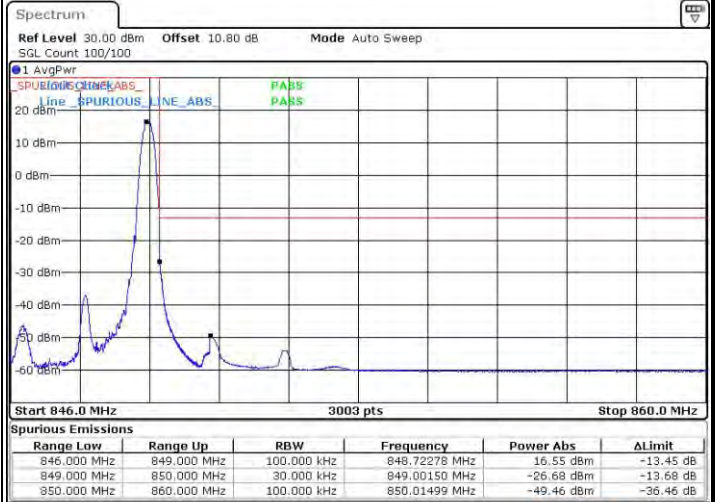

Date: 22 JUL 2019 20:44:47

Lowest Band Edge / Full RB



Date: 22 JUL 2019 20:40:46

Highest Band Edge / Full RB



Date: 22 JUL 2019 20:46:28



LTE Band 5 / 5MHz / QPSK

Lowest Band Edge / 1 RB

Highest Band Edge / 1 RB

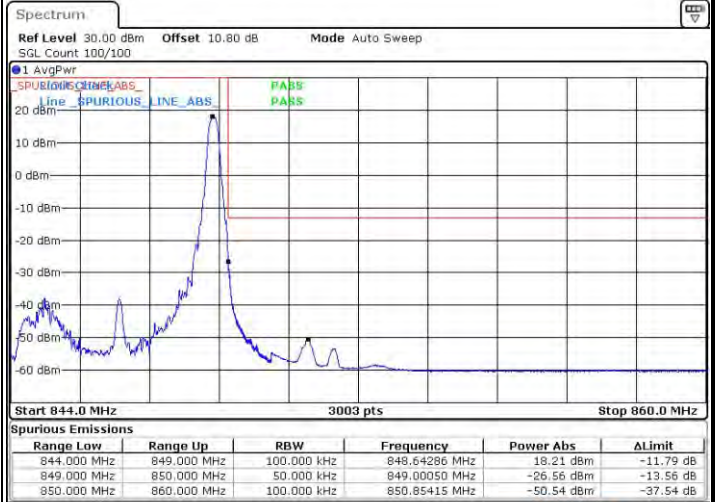
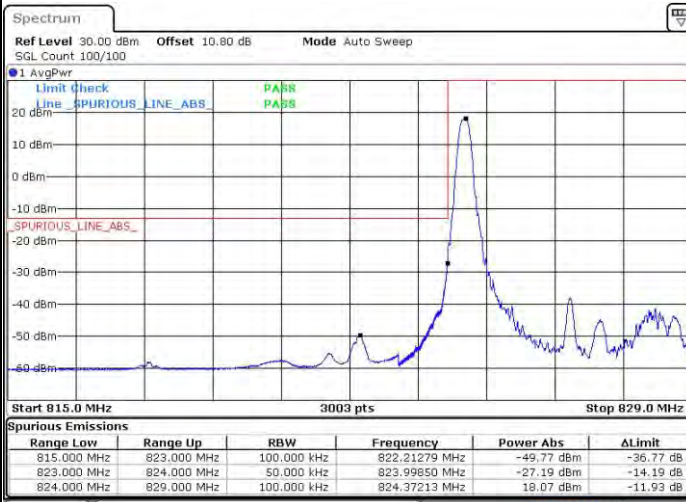

Date: 22 JUL 2019 20:49:45

Date: 22 JUL 2019 21:01:10

Lowest Band Edge / Full RB

Highest Band Edge / Full RB

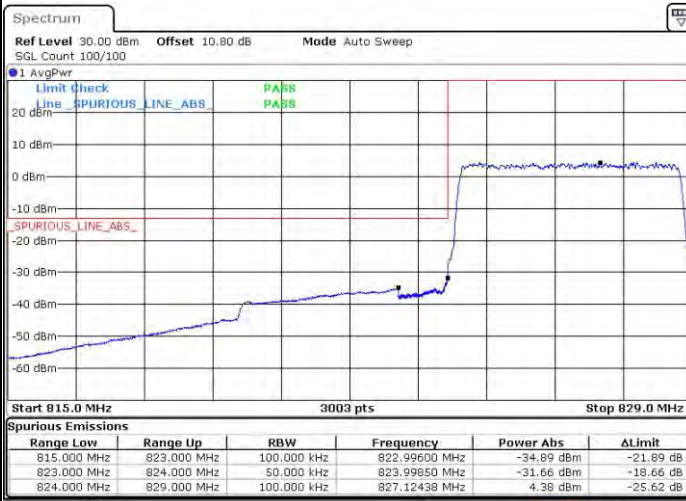

Date: 22 JUL 2019 20:53:07

Date: 22 JUL 2019 21:04:32



LTE Band 5 / 5MHz / 16QAM

Lowest Band Edge / 1RB

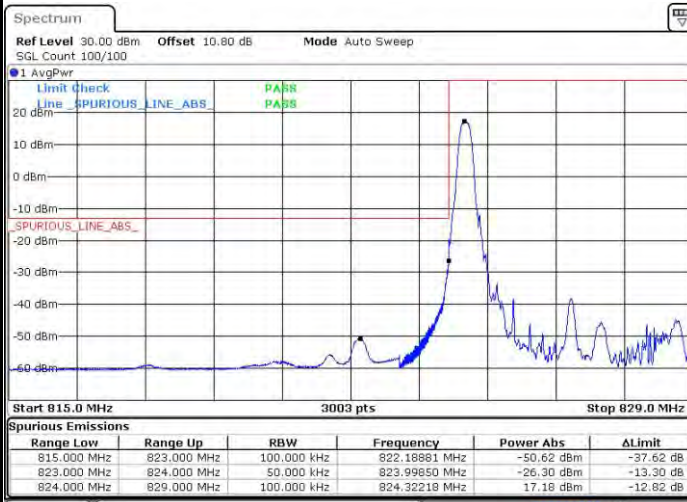

Date: 22 JUL 2019 20:51:26

Highest Band Edge / 1 RB

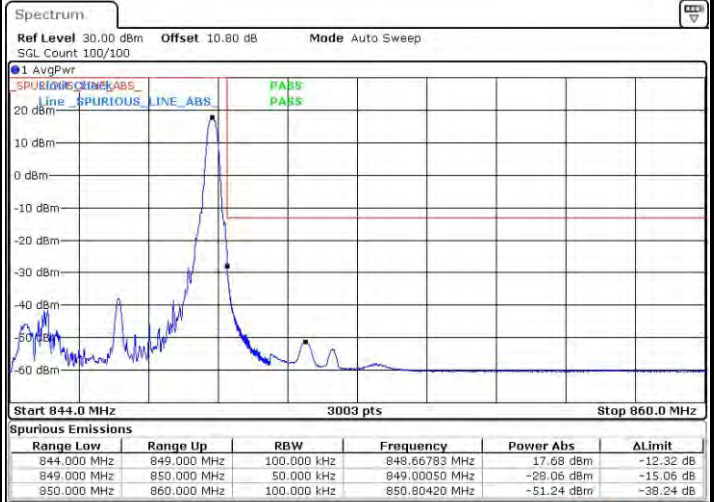

Date: 22 JUL 2019 21:02:51

Lowest Band Edge / Full RB

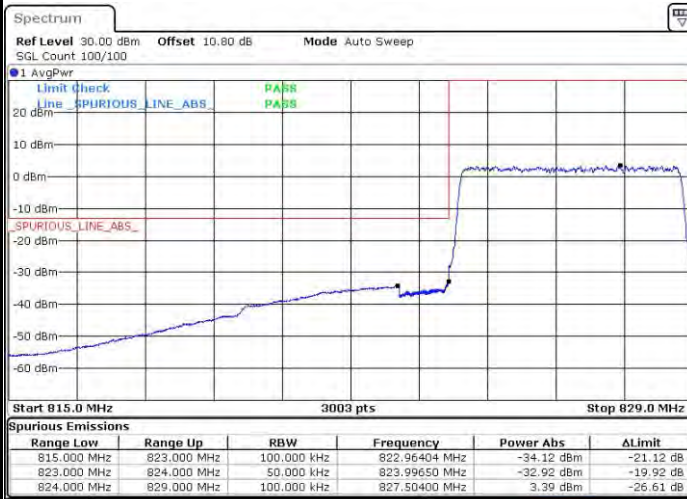

Date: 22 JUL 2019 20:54:48

Highest Band Edge / Full RB

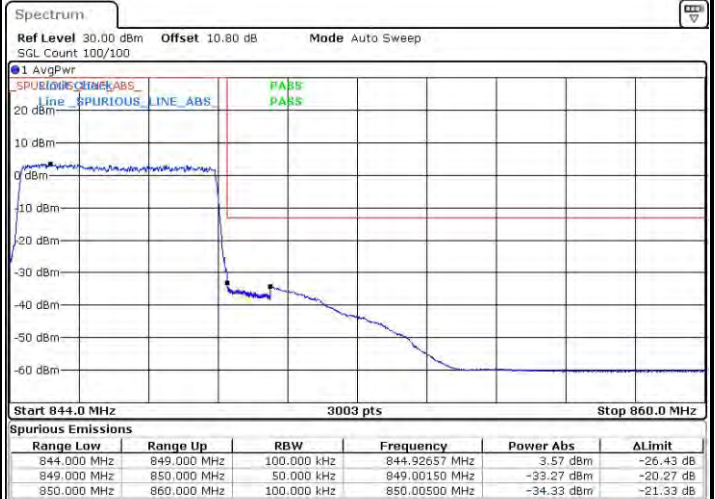

Date: 22 JUL 2019 21:06:13



LTE Band 5 / 5MHz / 64QAM

Lowest Band Edge / 1RB

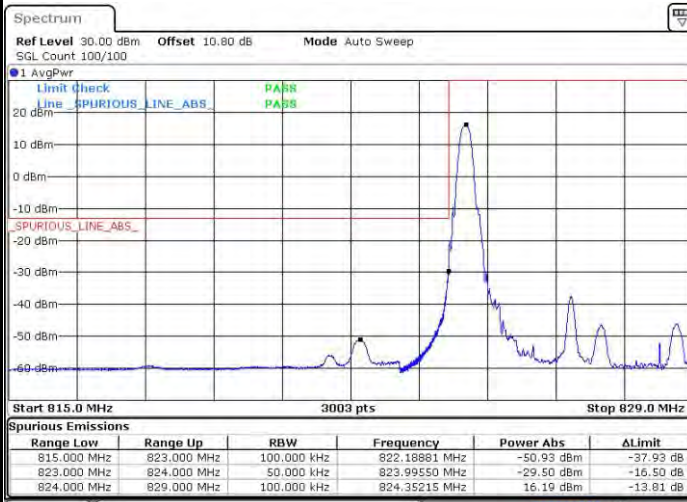

Date: 22 JUL 2019 21:09:52

Highest Band Edge / 1 RB

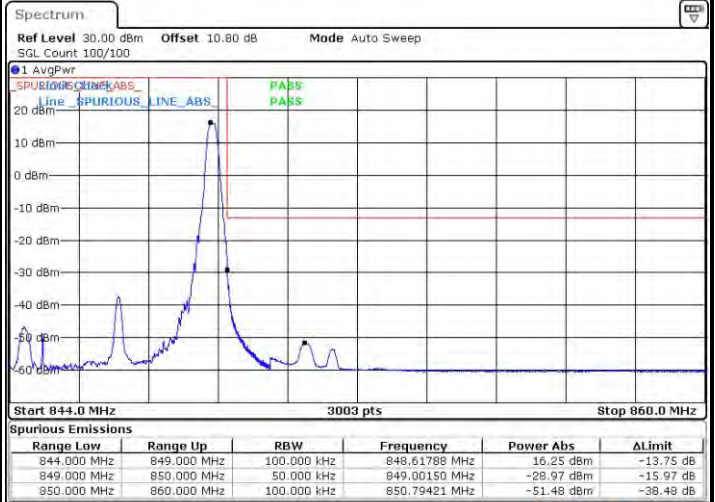

Date: 22 JUL 2019 21:15:34

Lowest Band Edge / Full RB

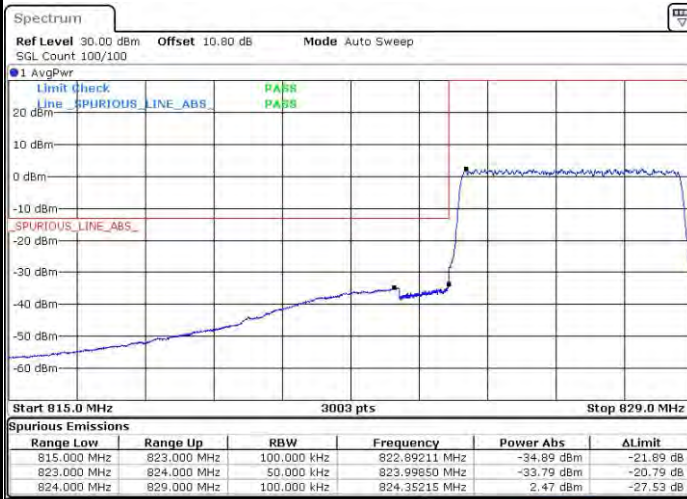

Date: 22 JUL 2019 21:11:33

Highest Band Edge / Full RB

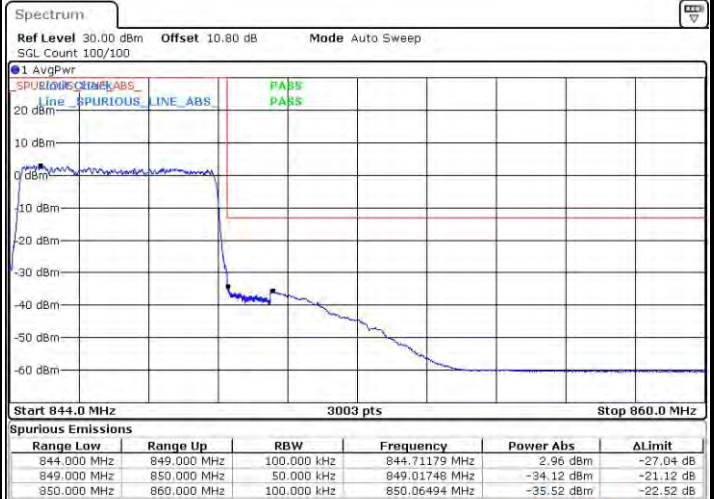

Date: 22 JUL 2019 21:17:15



LTE Band 5 / 10MHz / QPSK

Lowest Band Edge / 1 RB

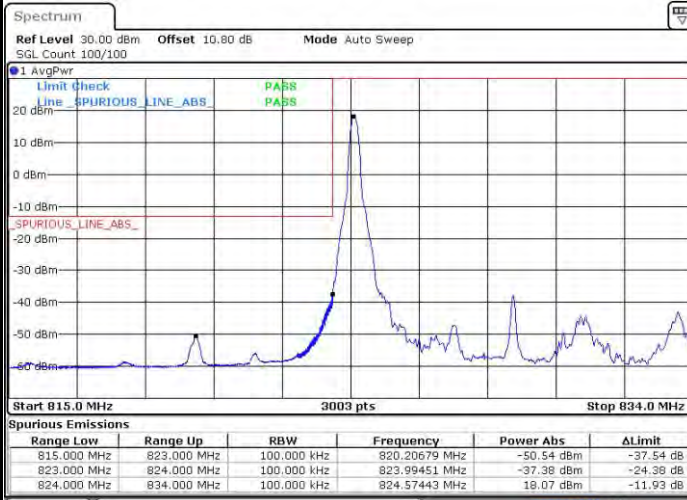

Date: 22 JUL 2019 21:19:46

Highest Band Edge / 1 RB

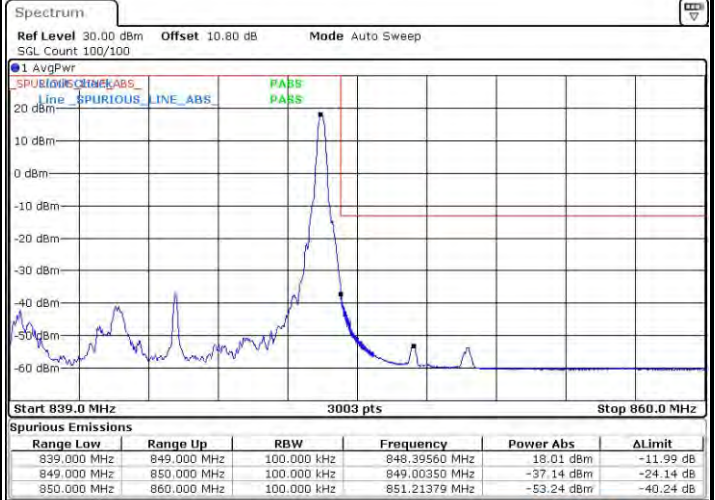

Date: 22 JUL 2019 21:36:17

Lowest Band Edge / Full RB

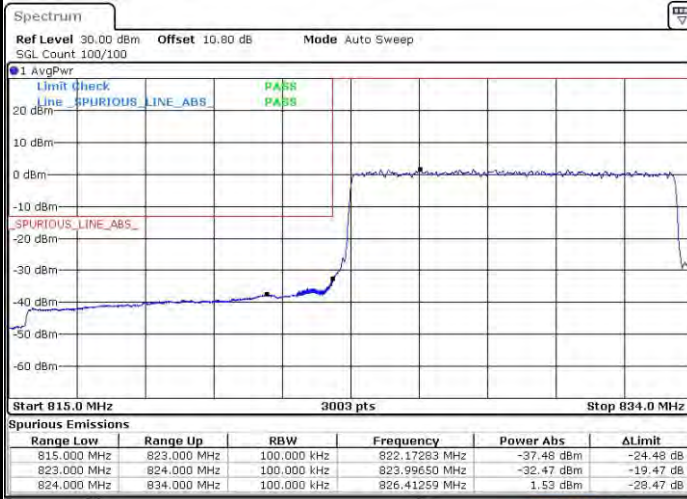

Date: 22 JUL 2019 21:23:09

Highest Band Edge / Full RB

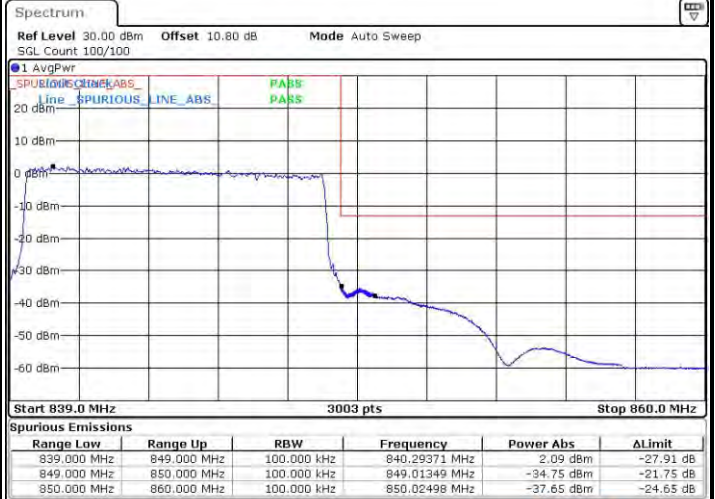

Date: 22 JUL 2019 21:39:40



LTE Band 5 / 10MHz / 16QAM

Lowest Band Edge / 1 RB

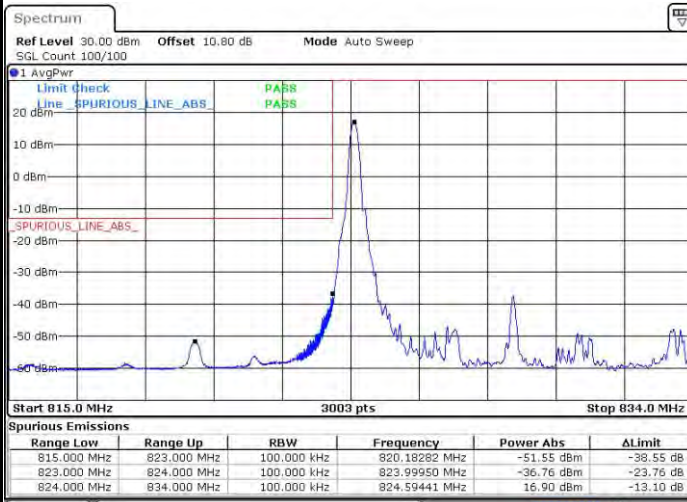

Date: 22 JUL 2019 21:21:27

Highest Band Edge / 1 RB

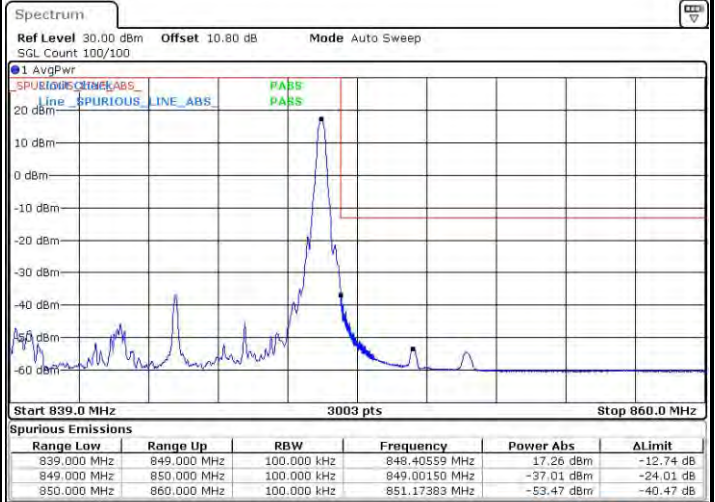

Date: 22 JUL 2019 21:37:59

Lowest Band Edge / Full RB

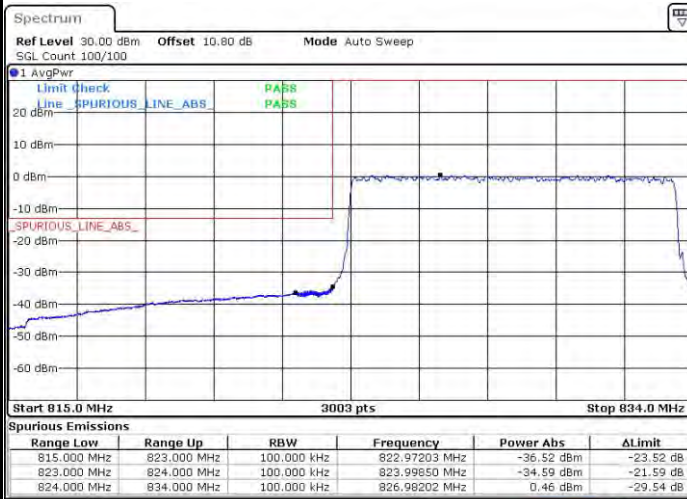

Date: 22 JUL 2019 21:24:50

Highest Band Edge / Full RB

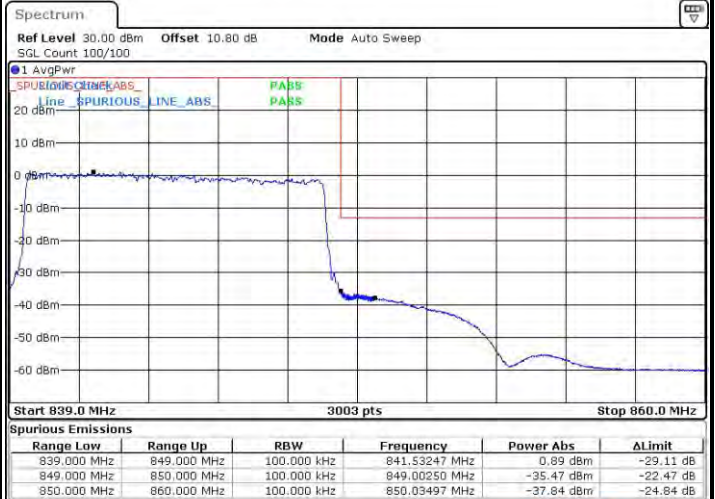

Date: 22 JUL 2019 21:41:21



LTE Band 5 / 10MHz / 64QAM

Lowest Band Edge / 1 RB

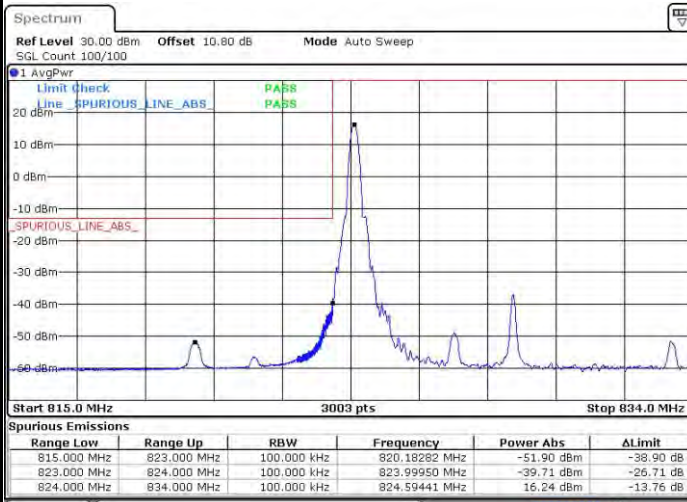

Date: 22 JUL 2019 21:45:47

Highest Band Edge / 1 RB

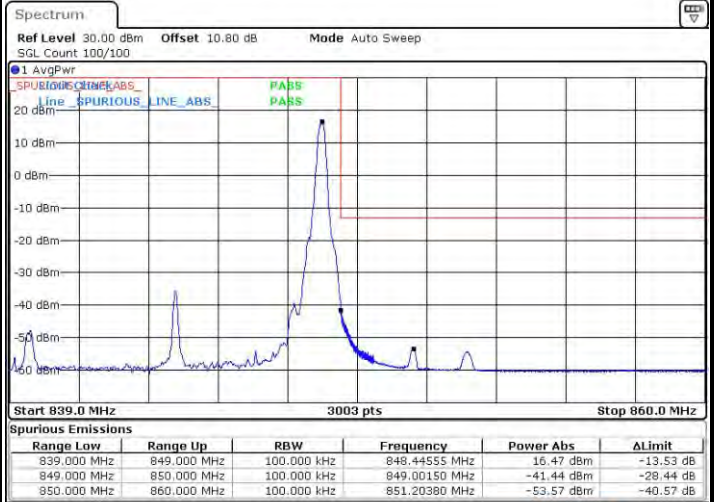

Date: 22 JUL 2019 21:51:29

Lowest Band Edge / Full RB

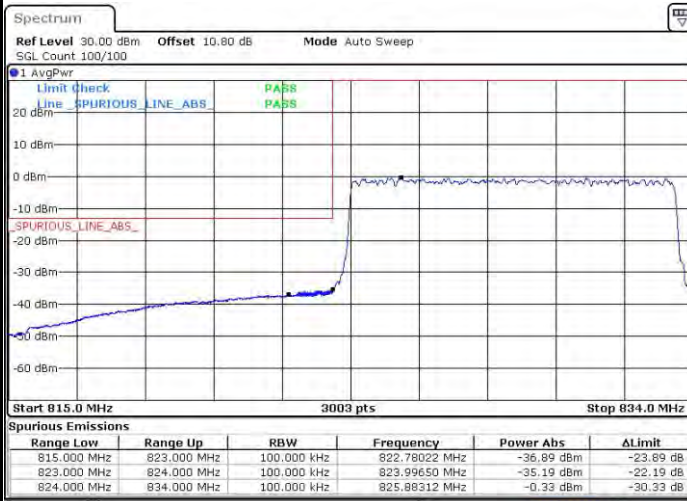

Date: 22 JUL 2019 21:47:28

Highest Band Edge / Full RB

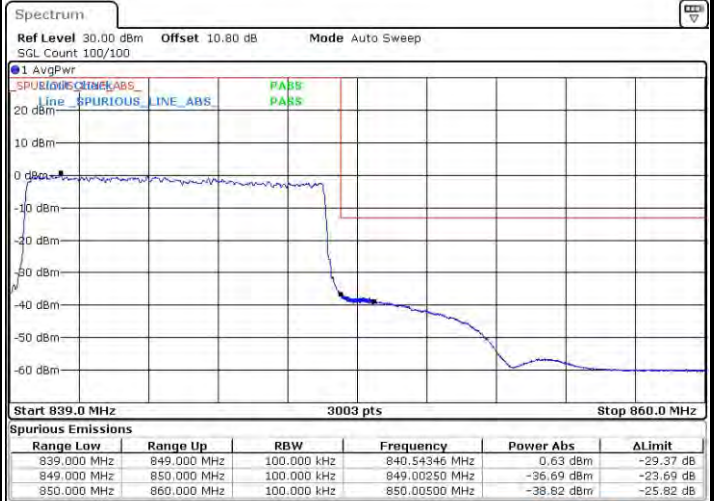

Date: 22 JUL 2019 21:53:10



Conducted Spurious Emission

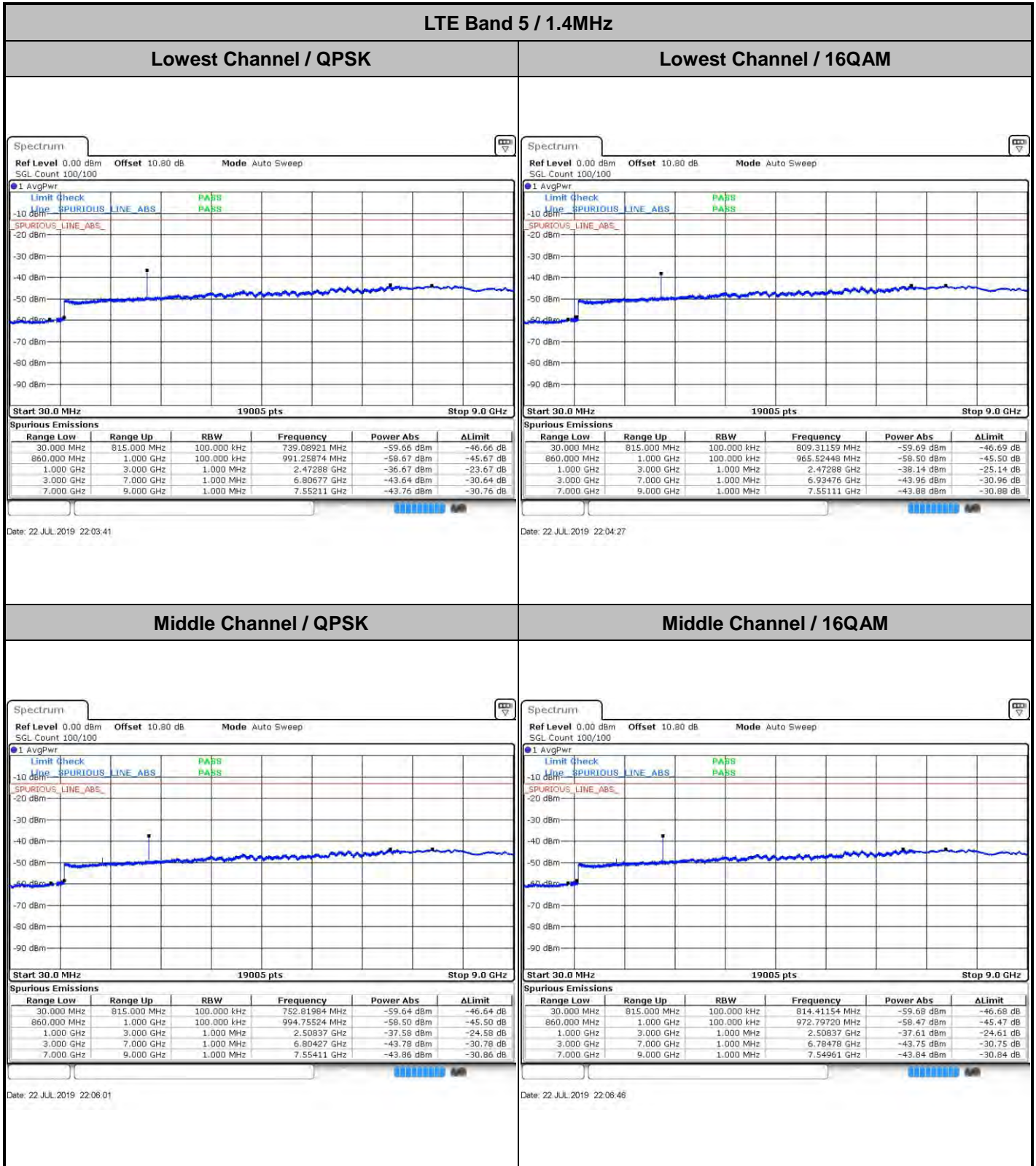



LTE Band 5 / 1.4MHz

Highest Channel / QPSK

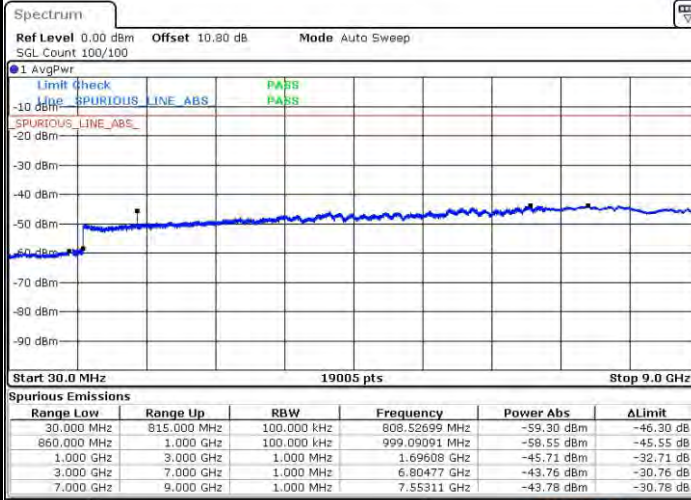

Date: 22 JUL 2019 22:15:06

Highest Channel / 16QAM

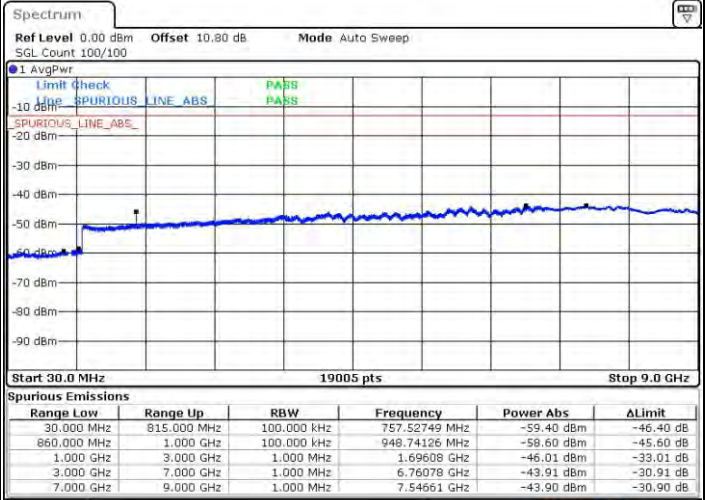

Date: 22 JUL 2019 22:15:53

LTE Band 5 / 3MHz

Lowest Channel / QPSK

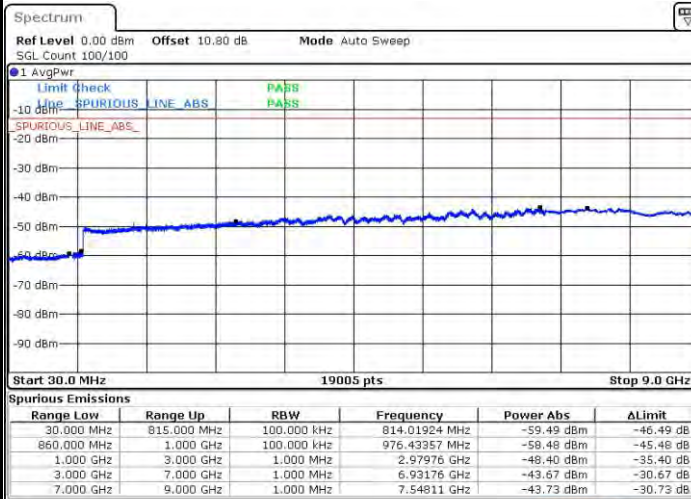

Date: 22 JUL 2019 20:24:47

Lowest Channel / 16QAM

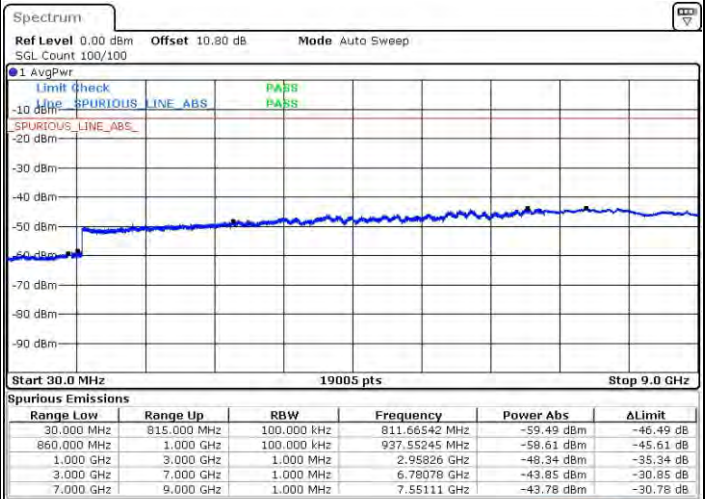

Date: 22 JUL 2019 20:25:33



LTE Band 5 / 3MHz

Middle Channel / QPSK

Middle Channel / 16QAM

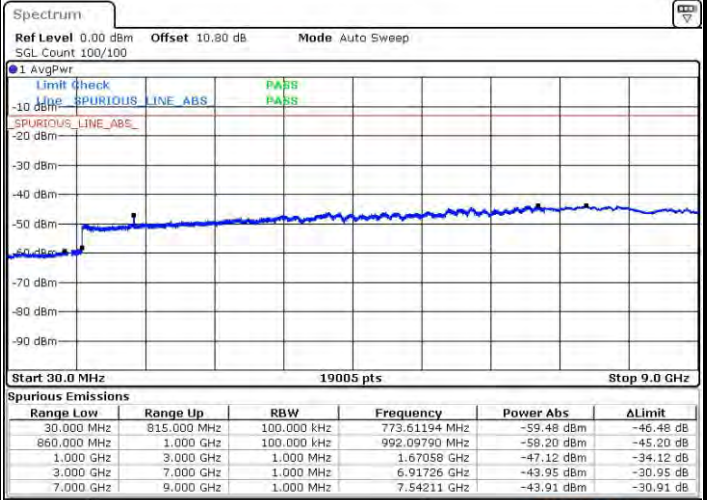
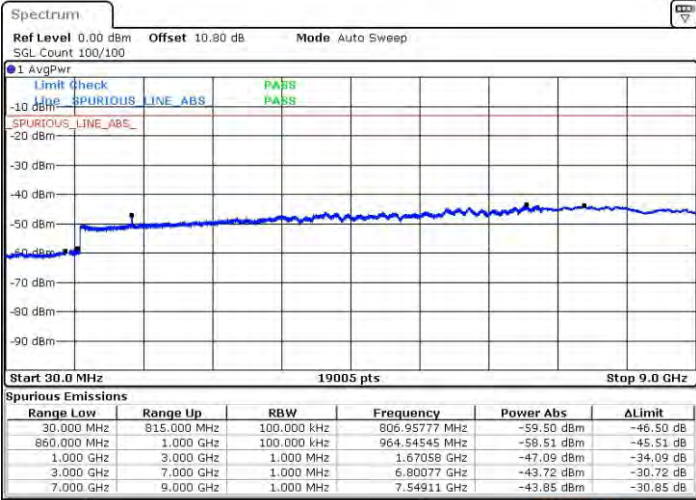

Date: 22 JUL 2019 20:27:07

Date: 22 JUL 2019 20:27:52

Highest Channel / QPSK

Highest Channel / 16QAM

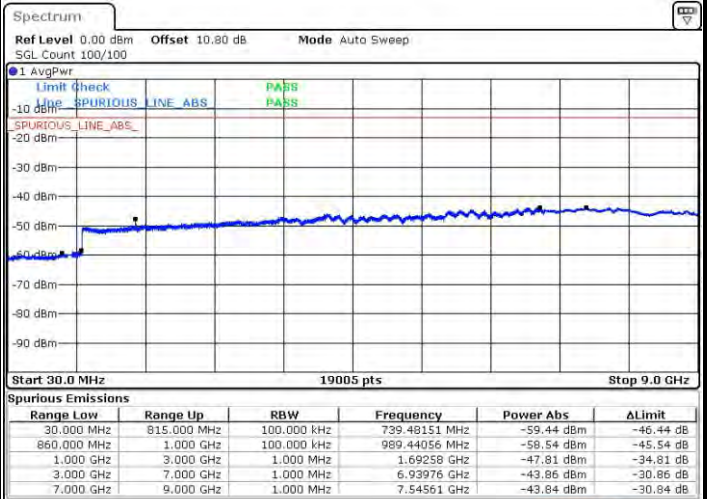
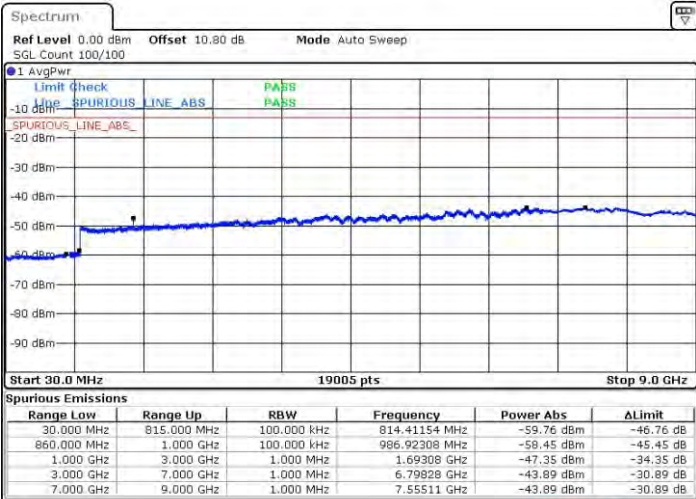

Date: 22 JUL 2019 20:36:12

Date: 22 JUL 2019 20:36:58



LTE Band 5 / 5MHz

Lowest Channel / QPSK

Lowest Channel / 16QAM

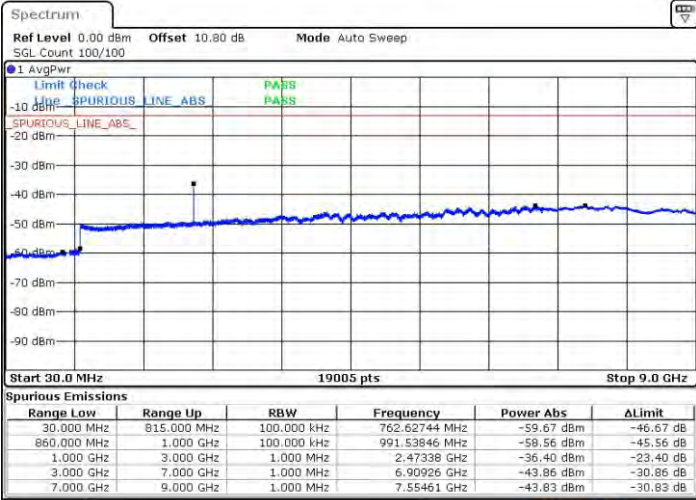

Date: 22 JUL 2019 20:55:35

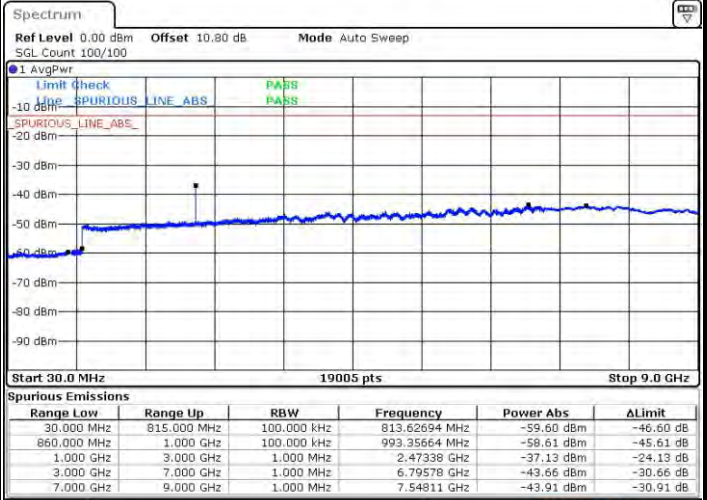

Date: 22 JUL 2019 20:56:21

Middle Channel / QPSK

Middle Channel / 16QAM

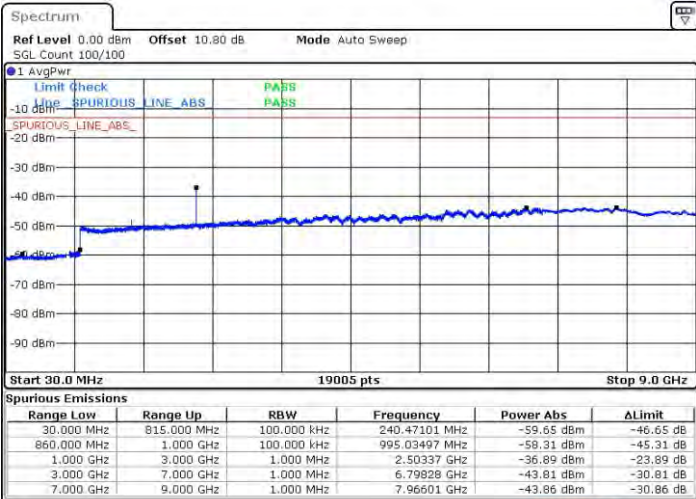

Date: 22 JUL 2019 20:57:54

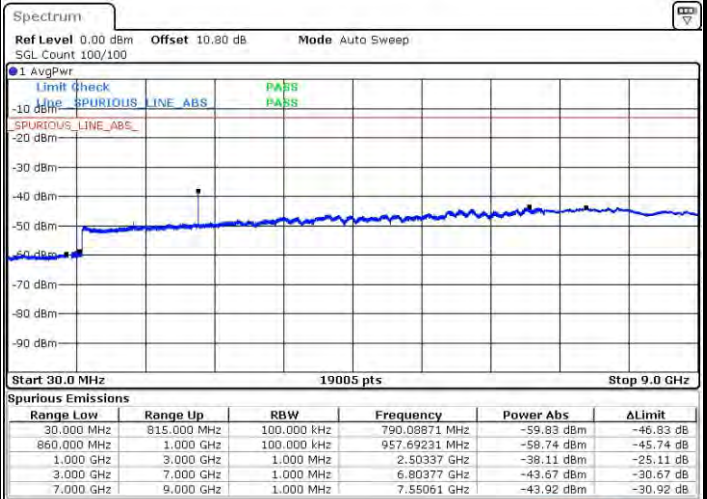

Date: 22 JUL 2019 20:58:40



LTE Band 5 / 5MHz

Highest Channel / QPSK

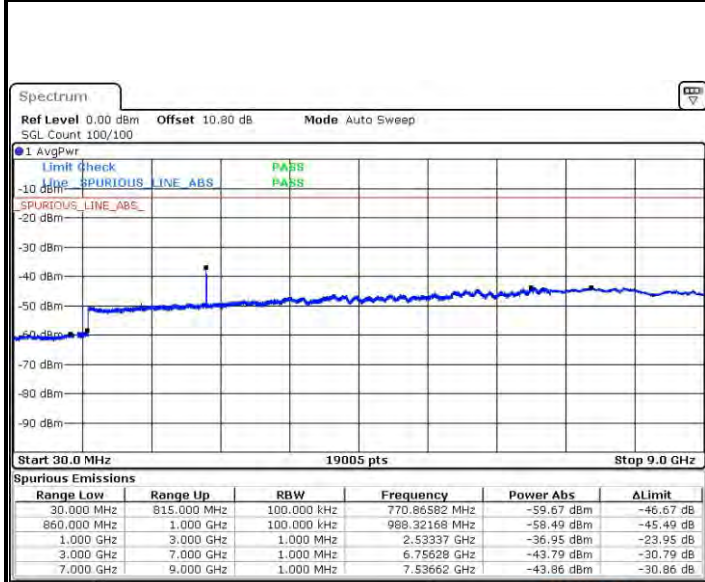

Date: 22 JUL 2019 21:07:00

Highest Channel / 16QAM

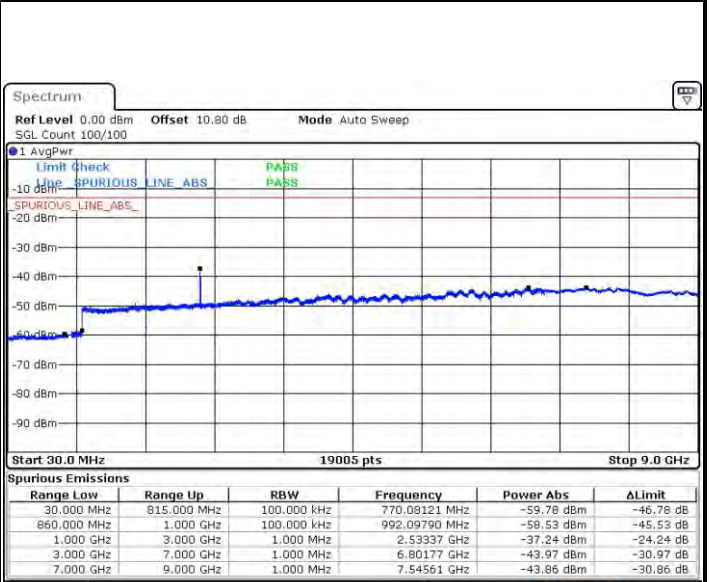

Date: 22 JUL 2019 21:07:46

LTE Band 5 / 10MHz

Lowest Channel / QPSK

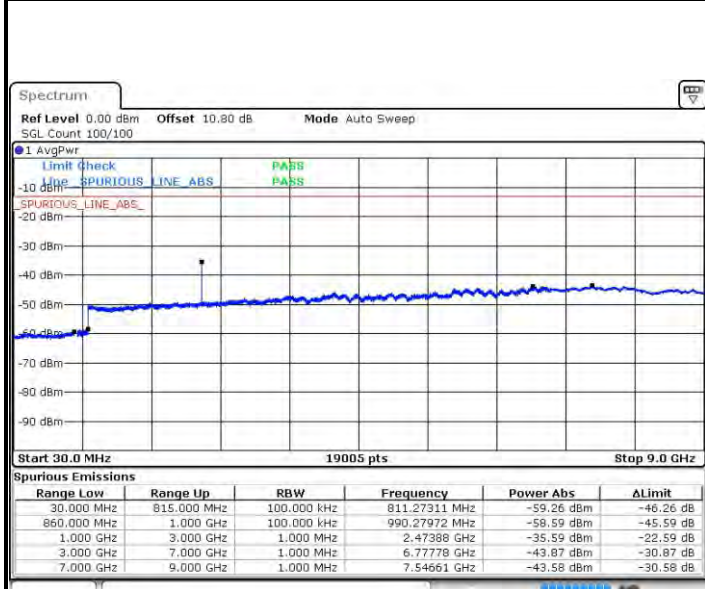

Date: 22 JUL 2019 21:25:36

Lowest Channel / 16QAM

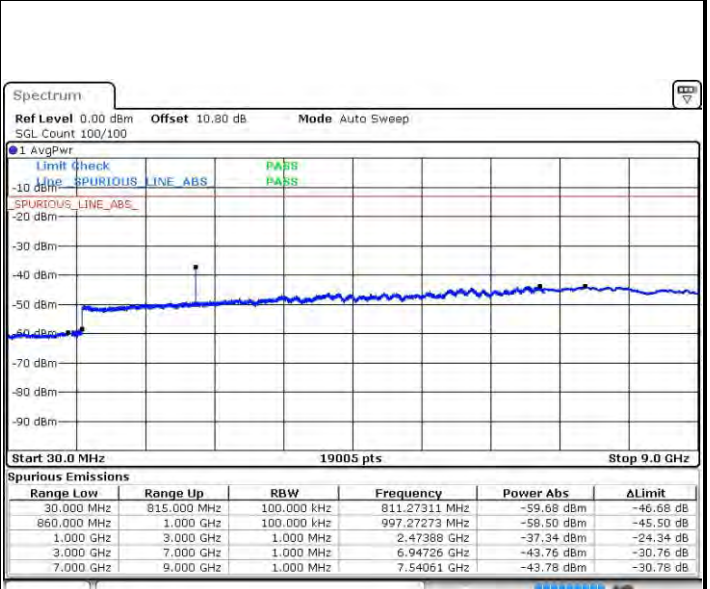

Date: 22 JUL 2019 21:26:22



LTE Band 5 / 10MHz

Middle Channel / QPSK

Middle Channel / 16QAM

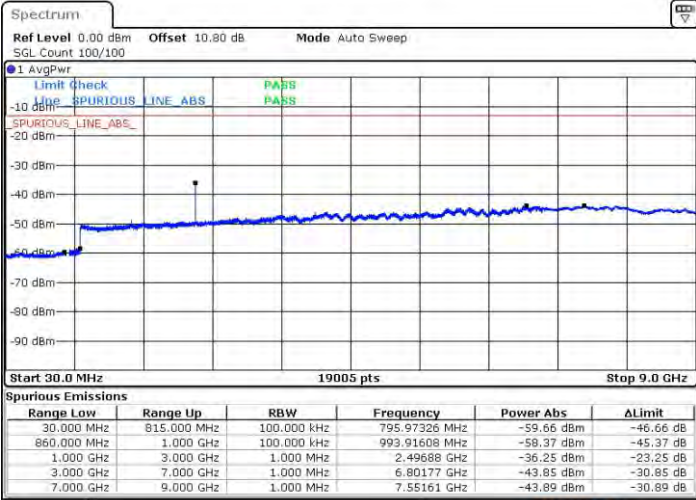

Date: 22 JUL 2019 21:27:55

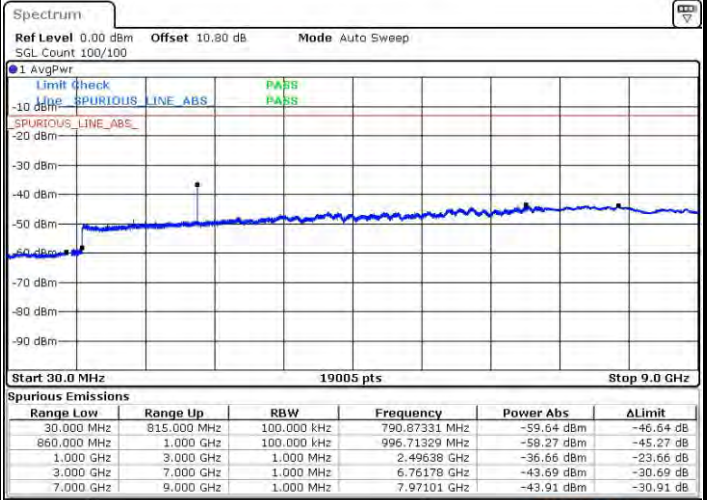

Date: 22 JUL 2019 21:28:41

Highest Channel / QPSK

Highest Channel / 16QAM

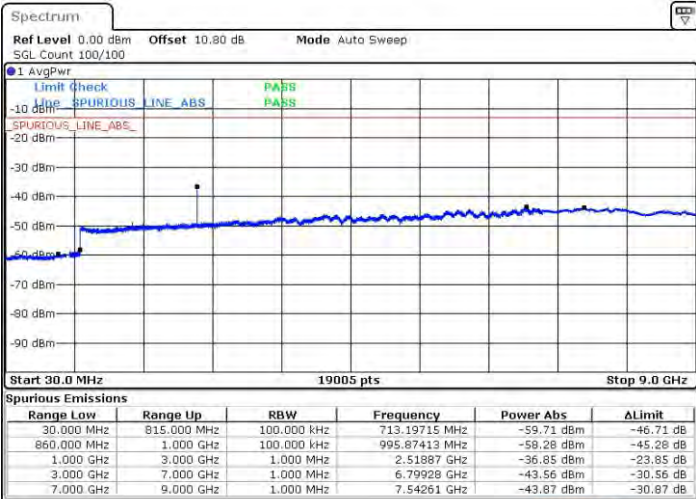

Date: 22 JUL 2019 21:42:08

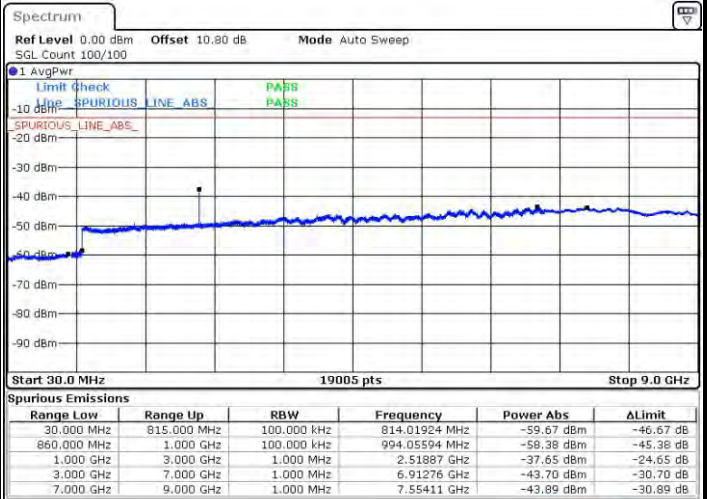

Date: 22 JUL 2019 21:42:54



LTE Band 5 / 1.4MHz

Lowest Channel / 64QAM

Middle Channel / 64QAM

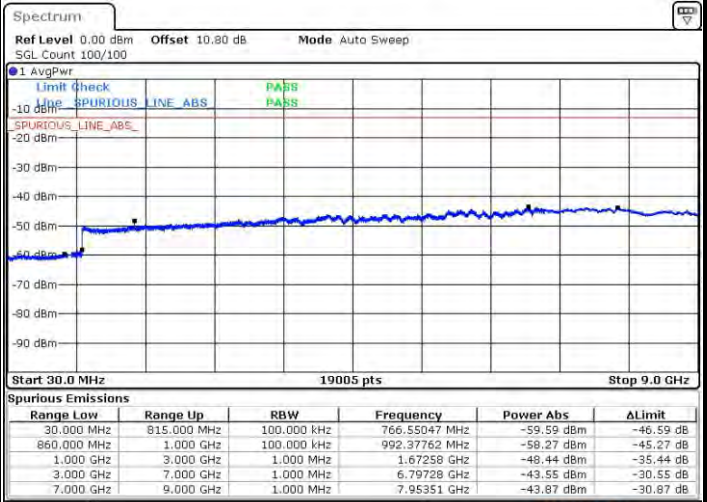
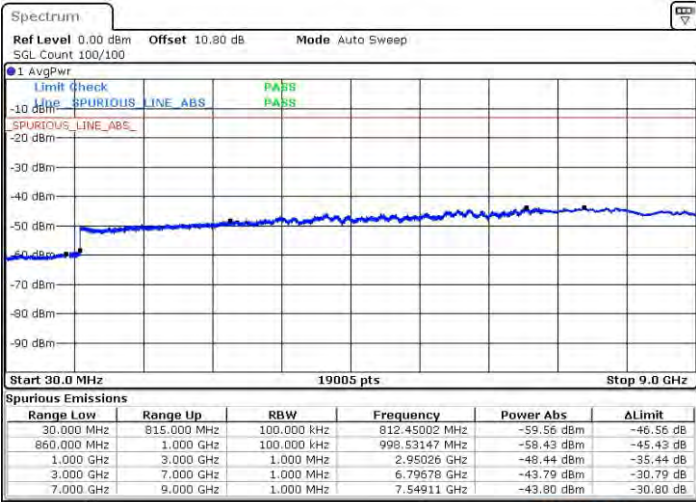

Date: 22 JUL 2019 22:20:26

Date: 22 JUL 2019 22:21:35

Highest Channel / 64QAM

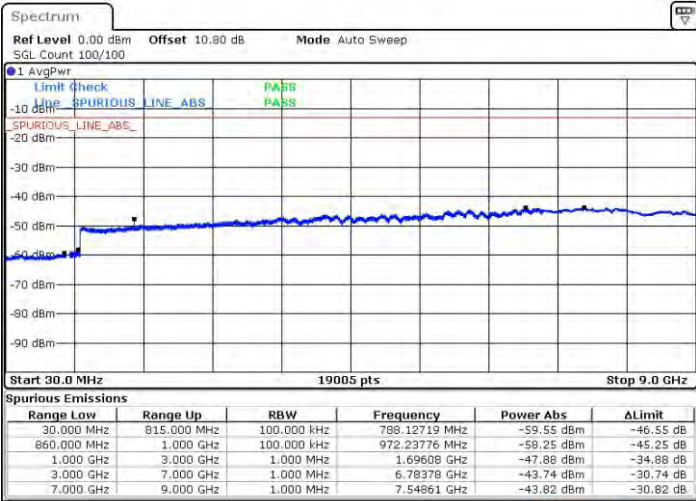

Date: 22 JUL 2019 22:26:08



LTE Band 5 / 3MHz

Lowest Channel / 64QAM

Middle Channel / 64QAM

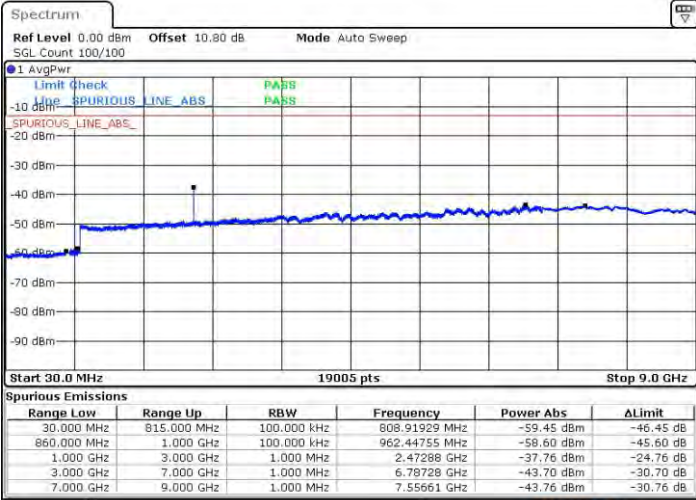

Date: 22 JUL 2019 20:41:32

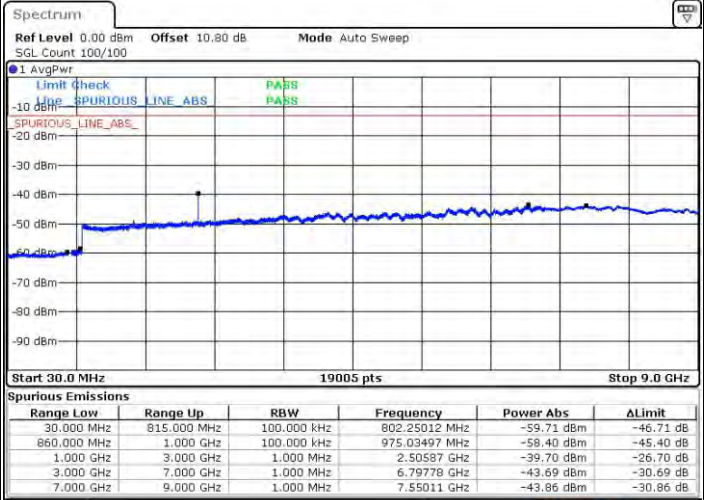

Date: 22 JUL 2019 20:42:42

Highest Channel / 64QAM

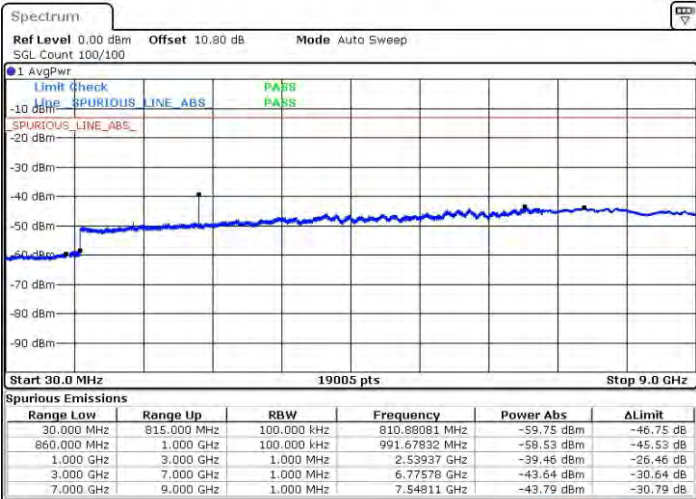

Date: 22 JUL 2019 20:47:14



LTE Band 5 / 5MHz

Lowest Channel / 64QAM

Middle Channel / 64QAM

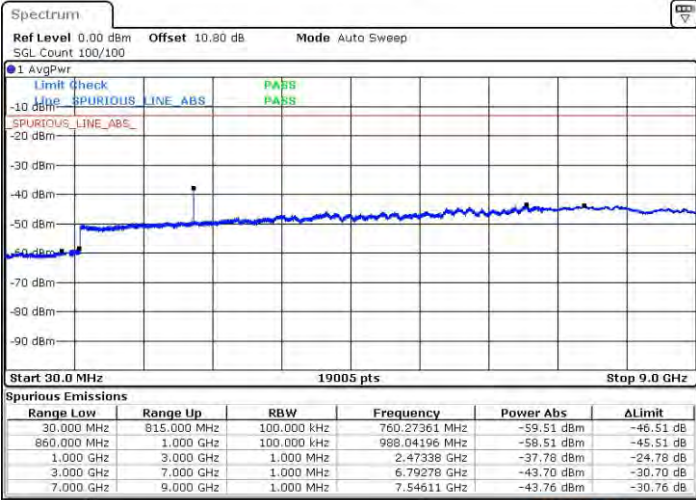

Date: 22 JUL 2019 21:12:19

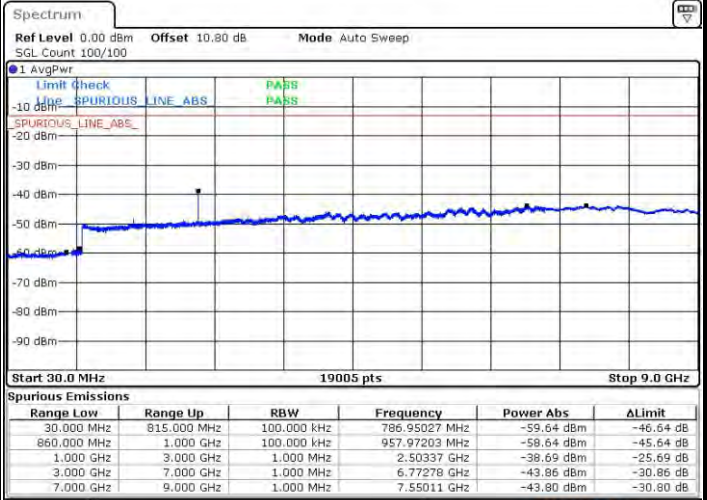

Date: 22 JUL 2019 21:13:29

Highest Channel / 64QAM

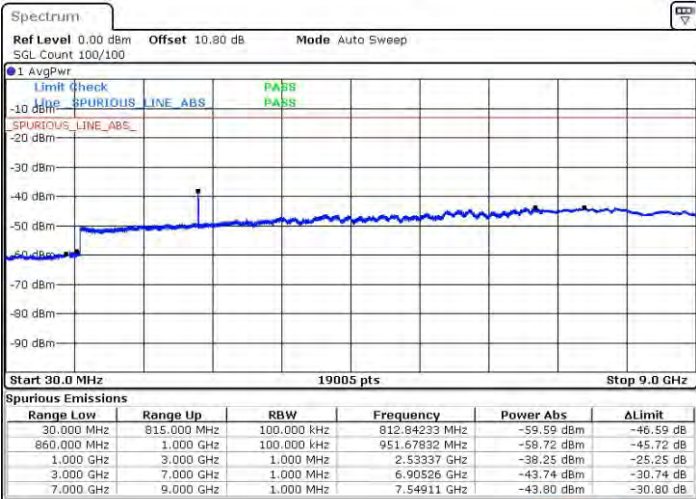

Date: 22 JUL 2019 21:43:41



LTE Band 5 / 10MHz

Lowest Channel / 64QAM

Middle Channel / 64QAM

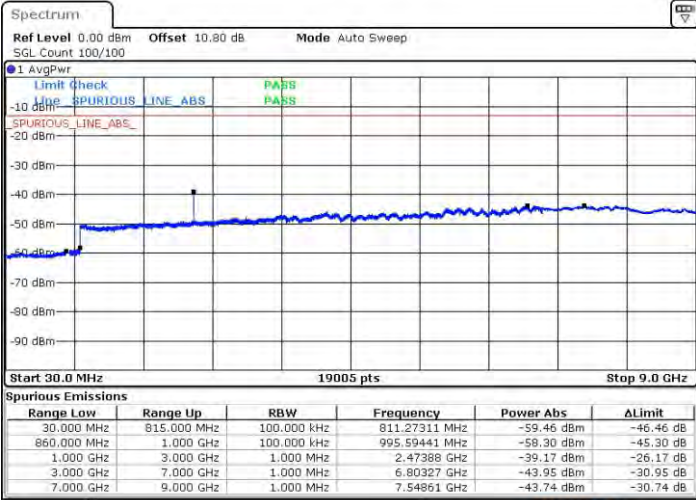

Date: 22 JUL 2019 21:48:14

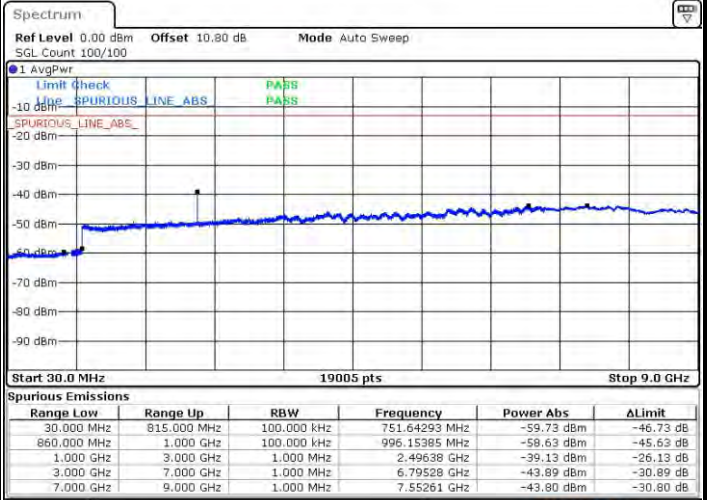

Date: 22 JUL 2019 21:49:24

Highest Channel / 64QAM

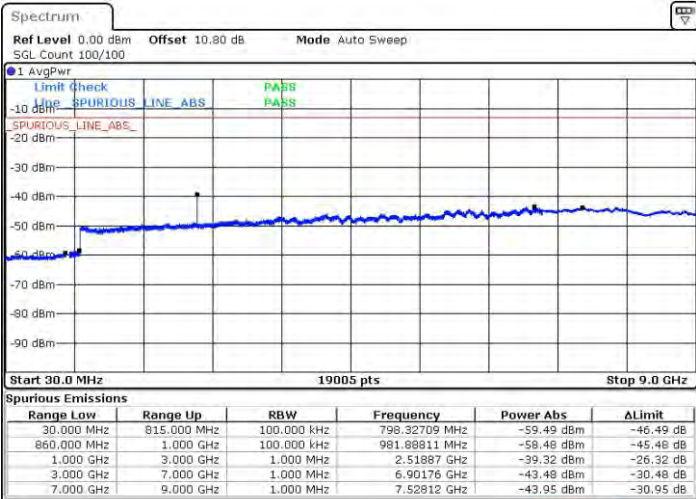

Date: 22 JUL 2019 21:53:57



Frequency Stability

Test Conditions		LTE Band 5 (QPSK) / Middle Channel	Limit
Temperature (°C)	Voltage (Volt)	BW 10MHz	2.5ppm
		Deviation (ppm)	Result
50	Normal Voltage	0.0008	PASS
40	Normal Voltage	0.0005	
30	Normal Voltage	0.0016	
20(Ref.)	Normal Voltage	0.0000	
10	Normal Voltage	0.0016	
0	Normal Voltage	0.0011	
-10	Normal Voltage	0.0118	
-20	Normal Voltage	0.0077	
-30	Normal Voltage	0.0025	
20	Maximum Voltage	0.0004	
20	Normal Voltage	0.0000	
20	Battery End Point	0.0013	

Note:

- 1. Normal Voltage =4.0 V. ; Battery End Point (BEP) =3.7V. ; Maximum Voltage =4.0 V.
- 2. The frequency fundamental emissions stay within the authorized frequency block.



LTE Band 12

Peak-to-Average Ratio

Mode	LTE Band 12 / 10MHz				
Mod.	QPSK		16QAM		Limit: 13dB
RB Size	1RB	Full RB	1RB	Full RB	Result
Lowest CH	3.65	4.75	5.16	5.88	PASS
Middle CH	3.65	4.67	5.42	5.97	
Highest CH	3.62	4.81	5.28	6.03	
Mode	LTE Band 12 / 10MHz				
Mod.	64QAM				Limit: 13dB
RB Size	1RB	Full RB			Result
Lowest CH	6.23	6.58	-	-	PASS
Middle CH	6.46	6.61	-	-	
Highest CH	6.06	6.67	-	-	



LTE Band 12 / 10MHz / QPSK

Lowest Channel / 1RB

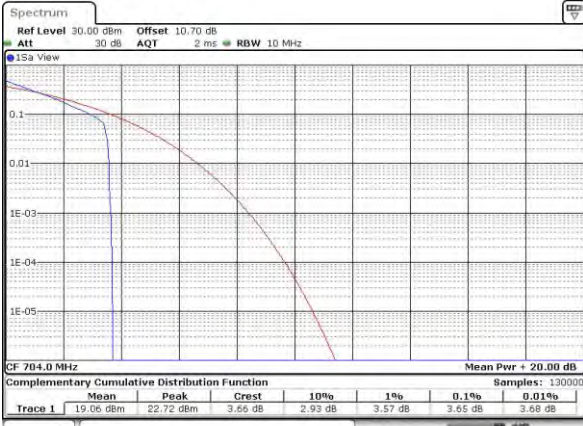

Date: 23 JUL 2019 01:27:14

Lowest Channel / Full RB



Date: 23 JUL 2019 01:27:03

Middle Channel / 1RB

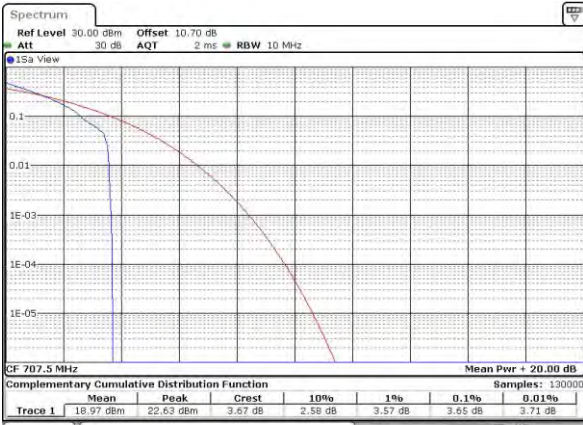

Date: 23 JUL 2019 01:27:24

Middle Channel / Full RB



Date: 23 JUL 2019 01:27:35

Highest Channel / 1RB



Date: 23 JUL 2019 01:27:56

Highest Channel / Full RB

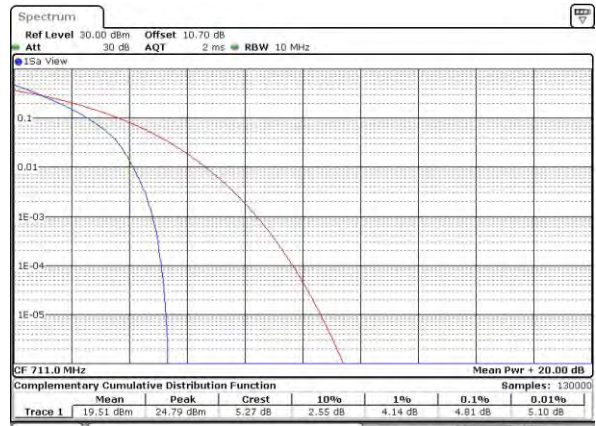

Date: 23 JUL 2019 01:27:45



LTE Band 12 / 10MHz / 16QAM

Lowest Channel / 1RB

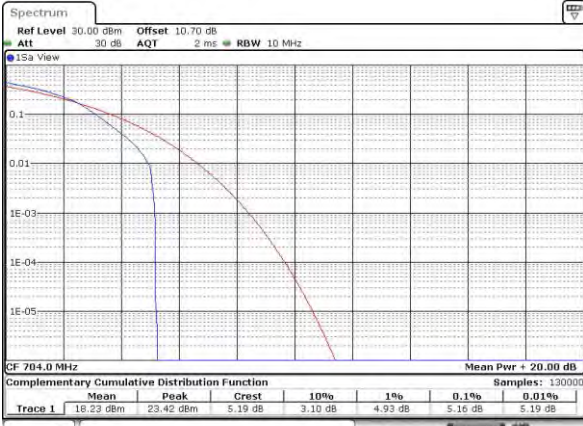

Date: 23 JUL 2019 01:26:10

Lowest Channel / Full RB



Date: 23 JUL 2019 01:25:59

Middle Channel / 1RB

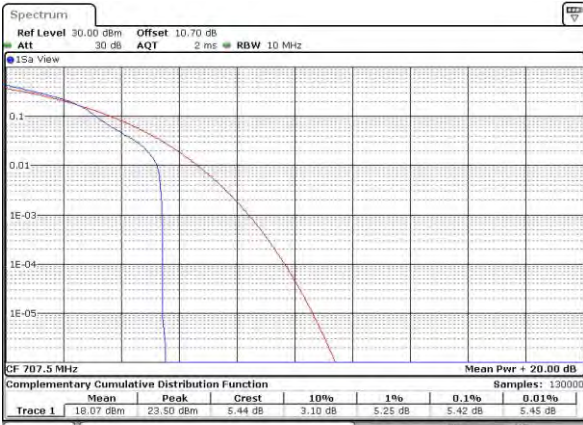

Date: 23 JUL 2019 01:26:20

Middle Channel / Full RB



Date: 23 JUL 2019 01:26:31

Highest Channel / 1RB

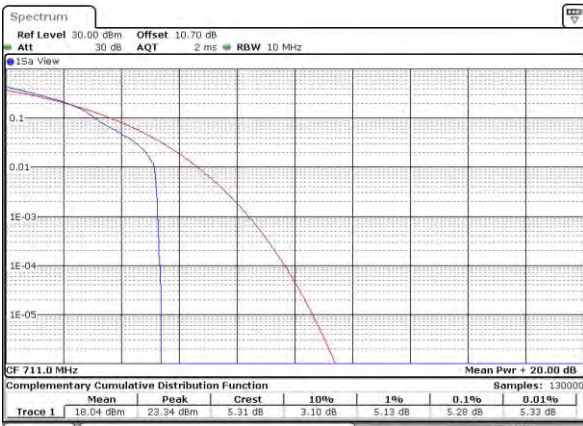

Date: 23 JUL 2019 01:26:52

Highest Channel / Full RB

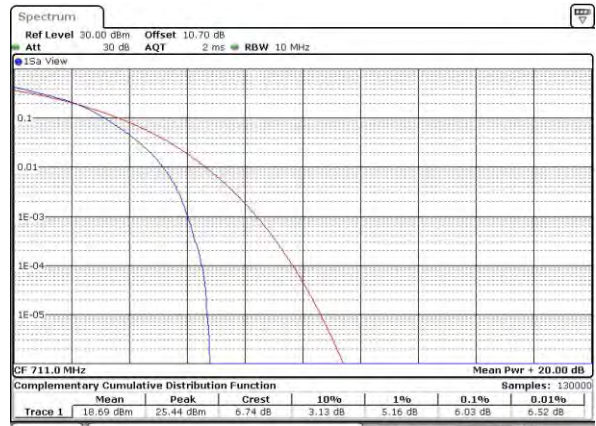

Date: 23 JUL 2019 01:26:41



LTE Band 12 / 10MHz / 64QAM

Lowest Channel / 1RB

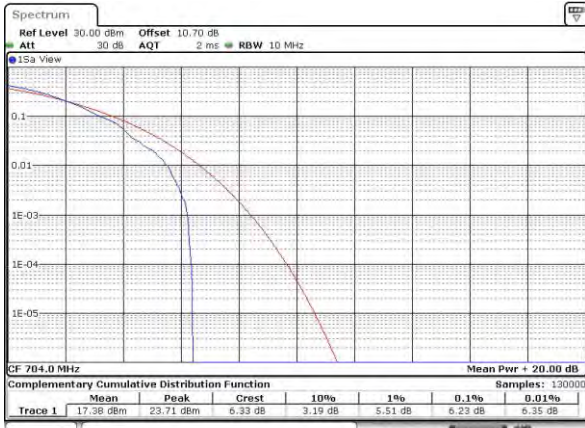

Date: 23 JUL 2019 01:25:06

Lowest Channel / Full RB

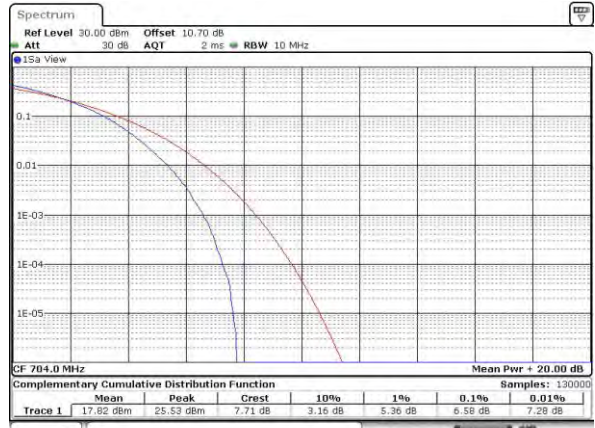

Date: 23 JUL 2019 01:24:55

Middle Channel / 1RB

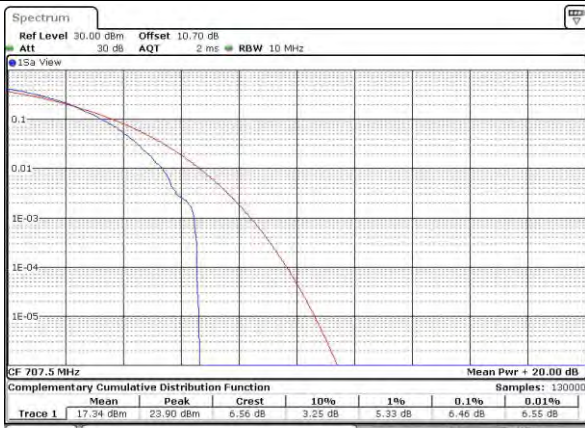

Date: 23 JUL 2019 01:25:17

Middle Channel / Full RB



Date: 23 JUL 2019 01:25:27

Highest Channel / 1RB

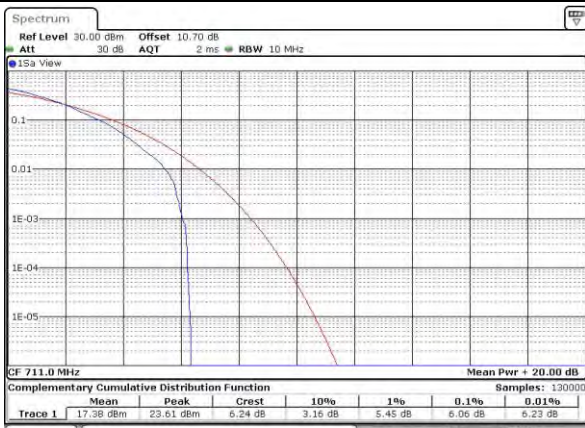

Date: 23 JUL 2019 01:25:48

Highest Channel / Full RB

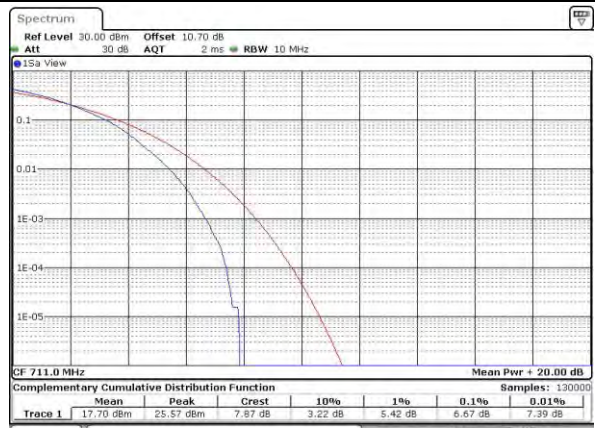

Date: 23 JUL 2019 01:25:37



26dB Bandwidth

Mode	LTE Band 12 : 26dB BW(MHz)											
BW	1.4MHz		3MHz		5MHz		10MHz		15MHz		20MHz	
Mod.	QPSK	16QAM	QPSK	16QAM	QPSK	16QAM	QPSK	16QAM	QPSK	16QAM	QPSK	16QAM
Lowest CH	1.23	1.23	3.00	3.07	4.93	4.90	9.65	9.77	-	-	-	-
Middle CH	1.22	1.23	3.02	3.03	4.87	4.81	10.01	9.85	-	-	-	-
Highest CH	1.23	1.21	2.98	3.01	4.91	4.93	9.69	9.89	-	-	-	-
Mode	LTE Band 12 : 26dB BW(MHz)											
BW	1.4MHz		3MHz		5MHz		10MHz		15MHz		20MHz	
Mod.	64QAM		64QAM		64QAM		64QAM		64QAM		64QAM	
Lowest CH	1.23	-	3.05	-	4.98	-	9.91	-	-	-	-	-
Middle CH	1.22	-	3.00	-	4.88	-	9.73	-	-	-	-	-
Highest CH	1.23	-	3.03	-	5.00	-	9.73	-	-	-	-	-



LTE Band 12

Lowest Channel / 1.4MHz / QPSK

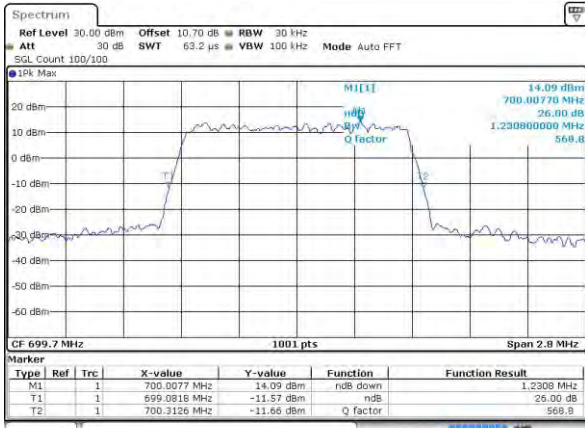

Date: 22 JUL 2019 23:46:41

Lowest Channel / 1.4MHz / 16QAM

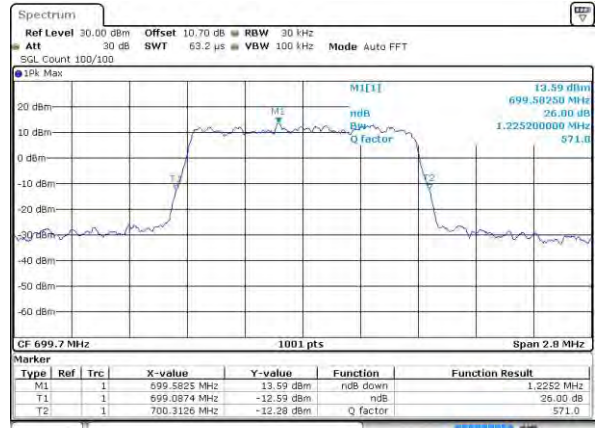

Date: 22 JUL 2019 23:46:29

Middle Channel / 1.4MHz / QPSK

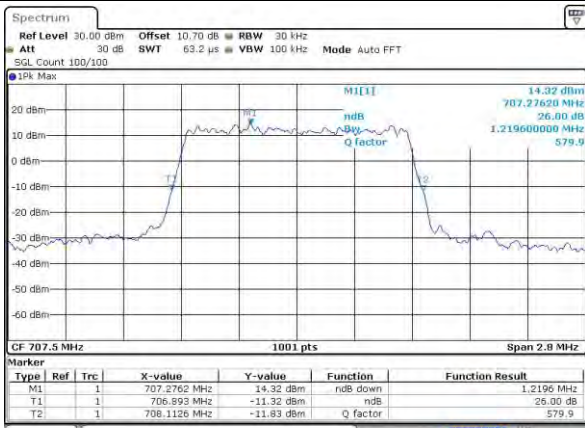

Date: 22 JUL 2019 23:52:53

Middle Channel / 1.4MHz / 16QAM

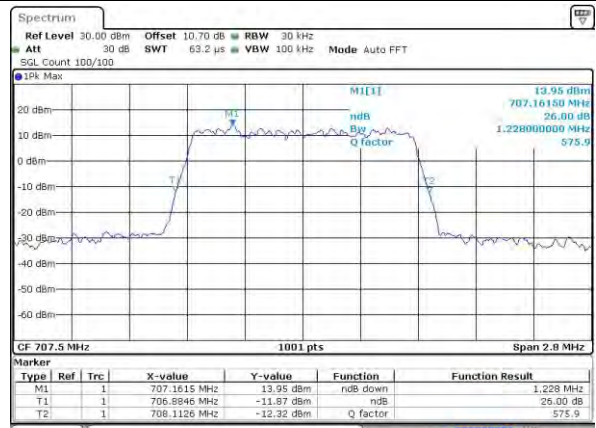

Date: 22 JUL 2019 23:53:05

Highest Channel / 1.4MHz / QPSK

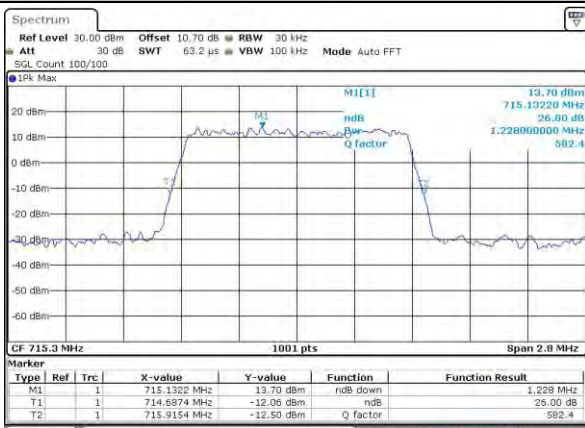

Date: 22 JUL 2019 23:55:28

Highest Channel / 1.4MHz / 16QAM

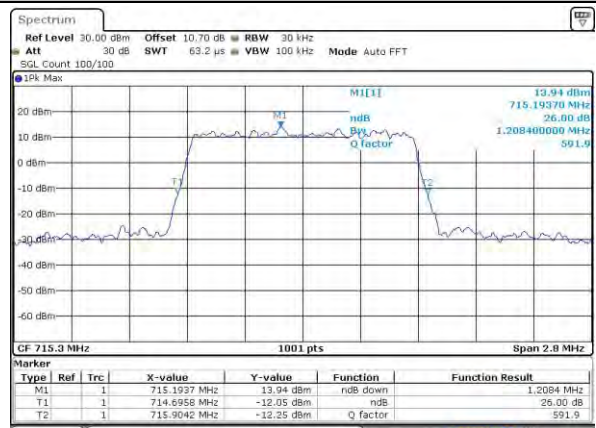

Date: 22 JUL 2019 23:55:13