

## System Check\_Head\_835MHz

**DUT: D835V2-499**

Communication System: CW; Frequency: 835 MHz; Duty Cycle: 1:1

Medium: HSL\_850\_170512 Medium parameters used:  $f = 835$  MHz;  $\sigma = 0.867$  S/m;  $\epsilon_r = 40.569$ ;  $\rho = 1000$  kg/m<sup>3</sup>

Ambient Temperature : 23.5 °C; Liquid Temperature : 22.5 °C

DASY5 Configuration:

- Probe: EX3DV4 - SN3955; ConvF(10.33, 10.33, 10.33); Calibrated: 2016/11/24;
- Sensor-Surface: 1.4mm (Mechanical Surface Detection)
- Electronics: DAE4 Sn1399; Calibrated: 2016/11/17
- Phantom: SAM-Left; Type: QD 000 P40 C; Serial: TP-1446
- Measurement SW: DASY52, Version 52.8 (8); SEMCAD X Version 14.6.10 (7331)

**Pin=250mW/Area Scan (61x61x1):** Interpolated grid: dx=1.500 mm, dy=1.500 mm

Maximum value of SAR (interpolated) = 3.03 W/kg

**Pin=250mW/Zoom Scan (5x5x7)/Cube 0:** Measurement grid: dx=8mm, dy=8mm, dz=5mm

Reference Value = 61.15 V/m; Power Drift = 0.00 dB

Peak SAR (extrapolated) = 3.44 W/kg

**SAR(1 g) = 2.28 W/kg; SAR(10 g) = 1.51 W/kg**

Maximum value of SAR (measured) = 3.02 W/kg

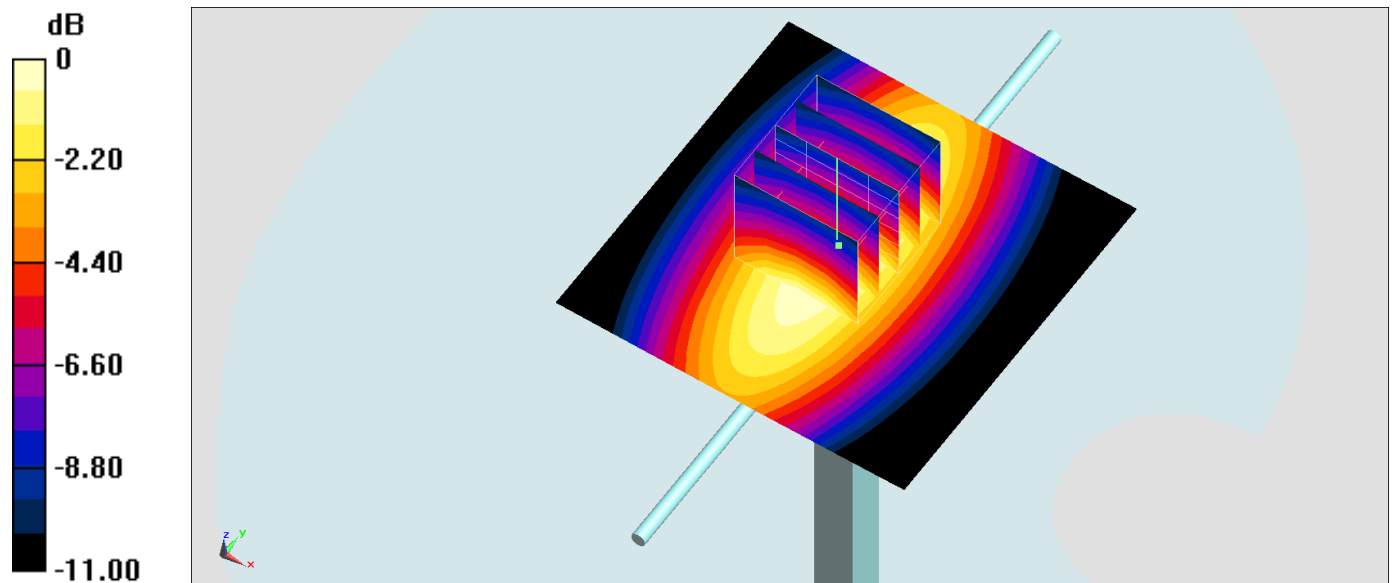

## System Check\_Body\_835MHz

### DUT: D835V2-499

Communication System: CW ; Frequency: 835 MHz;Duty Cycle: 1:1

Medium: MSL\_850\_170510 Medium parameters used:  $f = 835$  MHz;  $\sigma = 0.969$  S/m;  $\epsilon_r = 56.931$ ;  $\rho = 1000$  kg/m<sup>3</sup>

Ambient Temperature : 23.5 °C ; Liquid Temperature : 22.5 °C

#### DASY5 Configuration:

- Probe: EX3DV4 - SN3925; ConvF(9.91, 9.91, 9.91); Calibrated: 2016/5/26;
- Sensor-Surface: 1.4mm (Mechanical Surface Detection)
- Electronics: DAE3 Sn495; Calibrated: 2016/5/27
- Phantom: SAM\_Right; Type: QD000P40CD; Serial: 1884
- Measurement SW: DASY52, Version 52.8 (8);SEMCAD X Version 14.6.10 (7331)

**Pin=250mW/Area Scan (61x61x1):** Interpolated grid: dx=1.500 mm, dy=1.500 mm

Maximum value of SAR (interpolated) = 3.28 W/kg

**Pin=250mW/Zoom Scan (5x5x7)/Cube 0:** Measurement grid: dx=8mm, dy=8mm, dz=5mm

Reference Value = 60.79 V/m; Power Drift = 0.04 dB

Peak SAR (extrapolated) = 3.68 W/kg

**SAR(1 g) = 2.51 W/kg; SAR(10 g) = 1.68 W/kg**

Maximum value of SAR (measured) = 3.28 W/kg

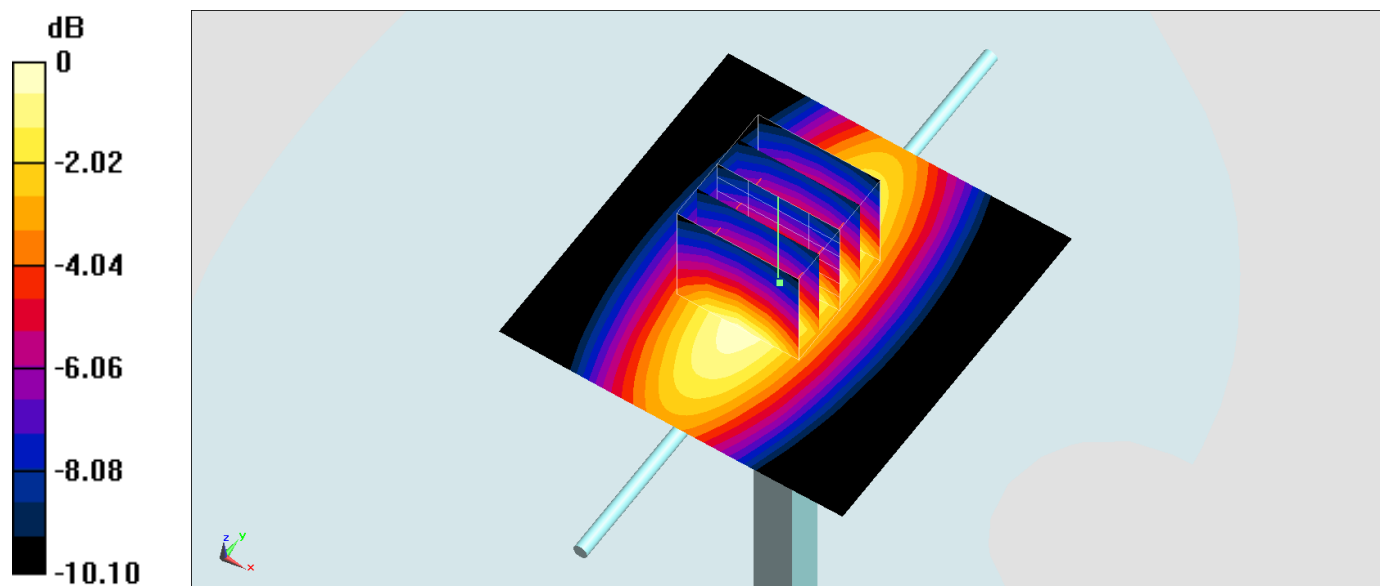

0 dB = 3.28 W/kg = 5.16 dBW/kg

## System Check\_Head\_1900MHz

### DUT: D1900V2-5d041

Communication System: CW; Frequency: 1900 MHz; Duty Cycle: 1:1

Medium: HSL\_1900\_170511 Medium parameters used:  $f = 1900$  MHz;  $\sigma = 1.396$  S/m;  $\epsilon_r = 38.367$ ;  $\rho = 1000$  kg/m<sup>3</sup>

Ambient Temperature : 23.4 °C; Liquid Temperature : 22.4 °C

### DASY5 Configuration:

- Probe: ES3DV3 - SN3270; ConvF(5.08, 5.08, 5.08); Calibrated: 2016/8/26;
- Sensor-Surface: 3mm (Mechanical Surface Detection)
- Electronics: DAE4 Sn778; Calibrated: 2016/5/12
- Phantom: SAM\_Right; Type: QD000P40CD; Serial: 1884
- Measurement SW: DASY52, Version 52.8 (8); SEMCAD X Version 14.6.10 (7331)

**Pin=250mW/Area Scan (61x61x1):** Interpolated grid: dx=1.500 mm, dy=1.500 mm

Maximum value of SAR (interpolated) = 13.4 W/kg

**Pin=250mW/Zoom Scan (5x5x7)/Cube 0:** Measurement grid: dx=8mm, dy=8mm, dz=5mm

Reference Value = 100.5 V/m; Power Drift = 0.04 dB

Peak SAR (extrapolated) = 18.3 W/kg

**SAR(1 g) = 10.3 W/kg; SAR(10 g) = 5.38 W/kg**

Maximum value of SAR (measured) = 12.8 W/kg

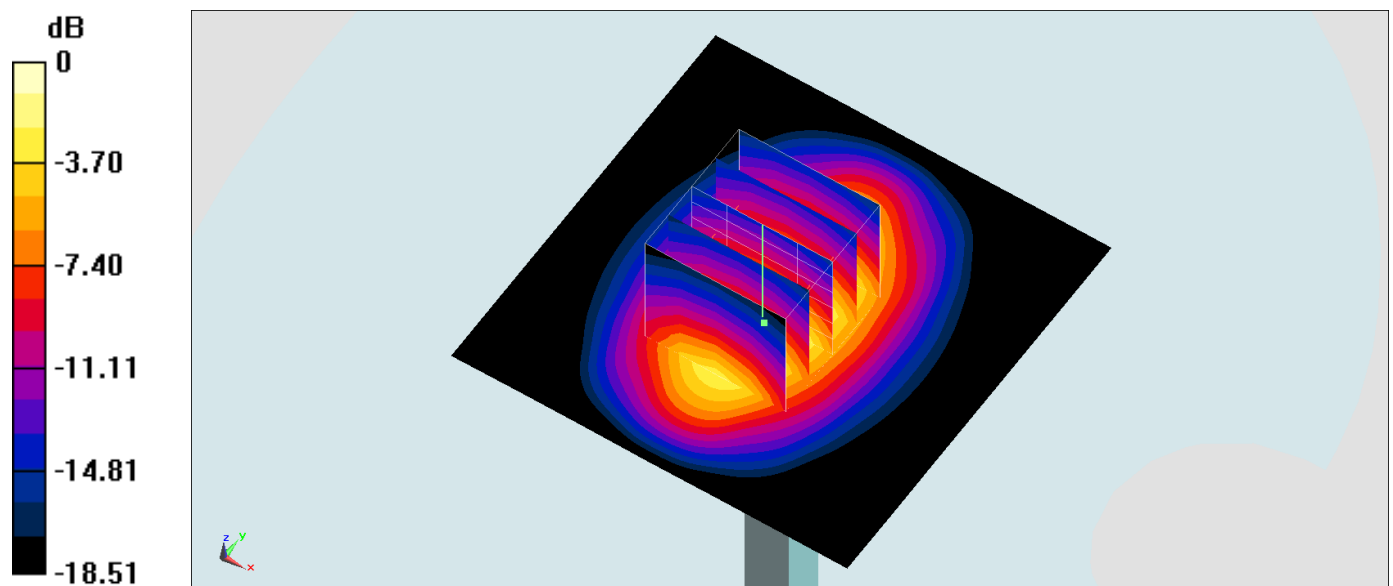

0 dB = 12.8 W/kg = 11.07 dBW/kg

## System Check\_Body\_1900MHz

### DUT: D1900V2-5d041

Communication System: CW; Frequency: 1900 MHz; Duty Cycle: 1:1

Medium: MSL\_1900\_170510 Medium parameters used:  $f = 1900$  MHz;  $\sigma = 1.535$  S/m;  $\epsilon_r = 53.015$ ;  $\rho = 1000$  kg/m<sup>3</sup>

Ambient Temperature : 23.7 °C; Liquid Temperature : 22.7 °C

### DASY5 Configuration:

- Probe: EX3DV4 - SN3925; ConvF(8, 8, 8); Calibrated: 2016/5/26;
- Sensor-Surface: 1.4mm (Mechanical Surface Detection)
- Electronics: DAE3 Sn495; Calibrated: 2016/5/27
- Phantom: SAM\_Right; Type: QD000P40CD; Serial: 1884
- Measurement SW: DASY52, Version 52.8 (8); SEMCAD X Version 14.6.10 (7331)

**Pin=250mW/Area Scan (61x61x1):** Interpolated grid: dx=1.500 mm, dy=1.500 mm

Maximum value of SAR (interpolated) = 16.1 W/kg

**Pin=250mW/Zoom Scan (5x5x7)/Cube 0:** Measurement grid: dx=8mm, dy=8mm, dz=5mm

Reference Value = 105.7 V/m; Power Drift = -0.03 dB

Peak SAR (extrapolated) = 17.9 W/kg

**SAR(1 g) = 9.97 W/kg; SAR(10 g) = 5.21 W/kg**

Maximum value of SAR (measured) = 15.1 W/kg

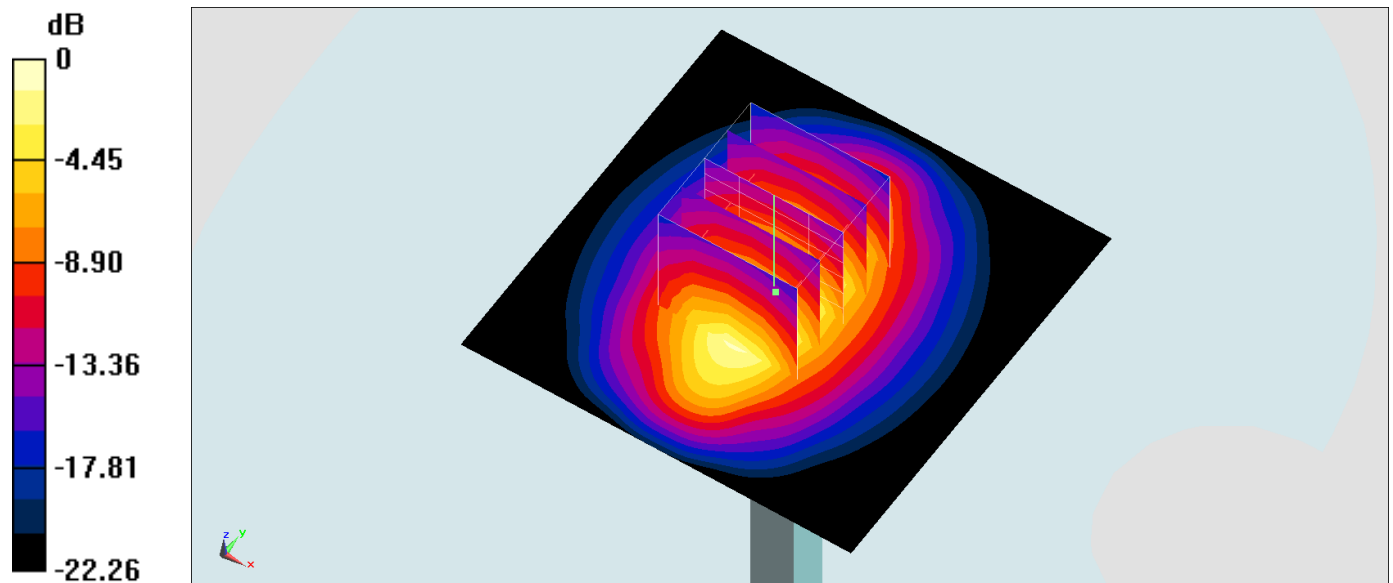

0 dB = 15.1 W/kg = 11.79 dBW/kg

## System Check\_Head\_2450MHz

### DUT: D2450V2-926

Communication System: CW; Frequency: 2450 MHz; Duty Cycle: 1:1

Medium: HSL\_2450\_170519 Medium parameters used:  $f = 2450$  MHz;  $\sigma = 1.79$  mho/m;  $\epsilon_r = 39.5$ ;  $\rho = 1000$  kg/m<sup>3</sup>

Ambient Temperature : 23.2 °C ; Liquid Temperature : 22.2 °C

### DASY4 Configuration:

- Probe: ES3DV3 - SN3270; ConvF(4.51, 4.51, 4.51); Calibrated: 2016/8/26
- Sensor-Surface: 3mm (Mechanical Surface Detection)
- Electronics: DAE4 Sn916; Calibrated: 2016/12/15
- Phantom: SAM\_Right; Type: QD000P40CD; Serial: TP:1815
- ;Postprocessing SW: SEMCAD, V1.8 Build 159

**Pin=250mW/Area Scan (61x61x1):** Measurement grid: dx=12mm, dy=12mm

Maximum value of SAR (interpolated) = 19.1 mW/g

**Pin=250mW/Zoom Scan (7x7x7)/Cube 0:** Measurement grid: dx=5mm, dy=5mm, dz=5mm

Reference Value = 95.4 V/m; Power Drift = 0.112 dB

Peak SAR (extrapolated) = 28.9 W/kg

**SAR(1 g) = 13.3 mW/g; SAR(10 g) = 6.02 mW/g**

Maximum value of SAR (measured) = 17.6 mW/g

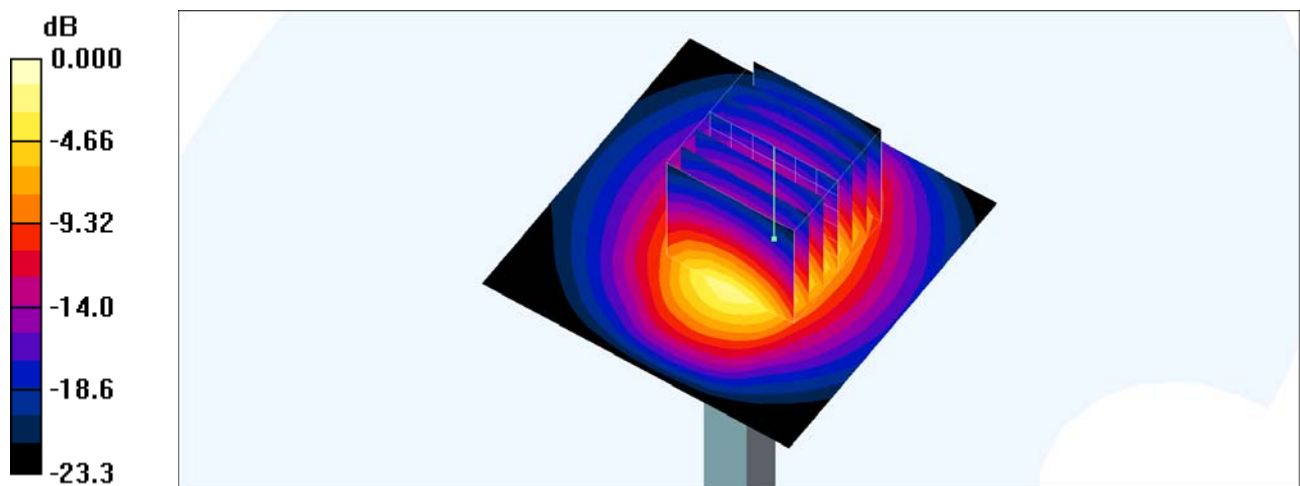

0 dB = 17.6mW/g

## System Check\_Head\_2450MHz

### DUT: D2450V2-926

Communication System: CW; Frequency: 2450 MHz; Duty Cycle: 1:1

Medium: HSL\_2450\_170527 Medium parameters used:  $f = 2450$  MHz;  $\sigma = 1.783$  S/m;  $\epsilon_r = 40.222$ ;

$\rho = 1000$  kg/m<sup>3</sup>

Ambient Temperature : 23.5 °C; Liquid Temperature : 22.5 °C

### DASY5 Configuration

- Probe: ES3DV3 - SN3169; ConvF(4.5, 4.5, 4.5); Calibrated: 2017/5/11;
- Sensor-Surface: 3mm (Mechanical Surface Detection)
- Electronics: DAE4 Sn853; Calibrated: 2016/7/11
- Phantom: SAM\_Right; Type: QD000P40CD; Serial: S/N:1801
- Measurement SW: DASY52, Version 52.8 (8); SEMCAD X Version 14.6.10 (7373)

**Pin=250mW/Area Scan (61x61x1):** Interpolated grid: dx=1.200 mm, dy=1.200 mm

Maximum value of SAR (interpolated) = 18.6 W/kg

**Pin=250mW/Zoom Scan (7x7x7)/Cube 0:** Measurement grid: dx=5mm, dy=5mm, dz=5mm

Reference Value = 104.3 V/m; Power Drift = -0.05 dB

Peak SAR (extrapolated) = 28.8 W/kg

**SAR(1 g) = 13.5 W/kg; SAR(10 g) = 6.19 W/kg**

Maximum value of SAR (measured) = 17.6 W/kg

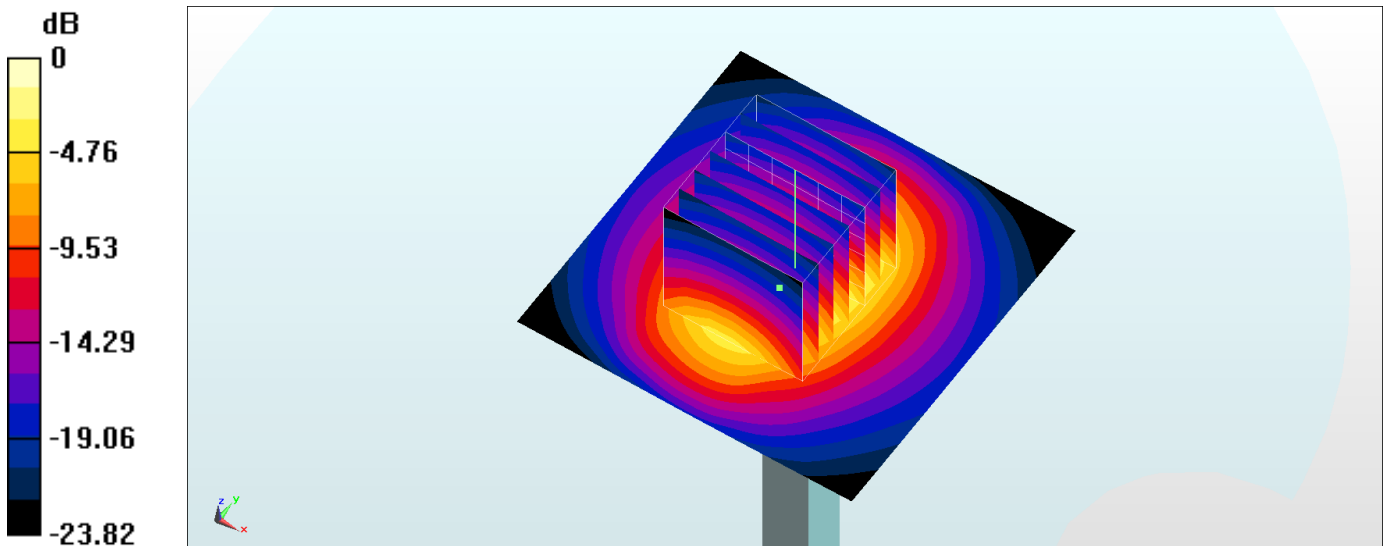

0 dB = 17.6 W/kg = 12.46 dBW/kg

## System Check\_Body\_2450MHz

### DUT: D2450V2-926

Communication System: CW; Frequency: 2450 MHz; Duty Cycle: 1:1

Medium: MSL\_2450\_170519 Medium parameters used:  $f = 2450$  MHz;  $\sigma = 1.95$  mho/m;  $\epsilon_r = 54.8$ ;  $\rho = 1000$  kg/m<sup>3</sup>

Ambient Temperature : 23.2 °C ; Liquid Temperature : 22.2 °C

#### DASY4 Configuration:

- Probe: ES3DV3 - SN3270; ConvF(4.28, 4.28, 4.28); Calibrated: 2016/8/26
- Sensor-Surface: 3mm (Mechanical Surface Detection)
- Electronics: DAE4 Sn916; Calibrated: 2016/12/15
- Phantom: SAM\_Right; Type: QD000P40CD; Serial: TP:1815
- ;Postprocessing SW: SEMCAD, V1.8 Build 159

**Pin=250mW/Area Scan (61x61x1):** Measurement grid: dx=12mm, dy=12mm

Maximum value of SAR (interpolated) = 19.3 mW/g

**Pin=250mW/Zoom Scan (7x7x7)/Cube 0:** Measurement grid: dx=5mm, dy=5mm, dz=5mm

Reference Value = 107.5 V/m; Power Drift = -0.079 dB

Peak SAR (extrapolated) = 25.4 W/kg

**SAR(1 g) = 12.4 mW/g; SAR(10 g) = 5.77 mW/g**

Maximum value of SAR (measured) = 18.9 mW/g

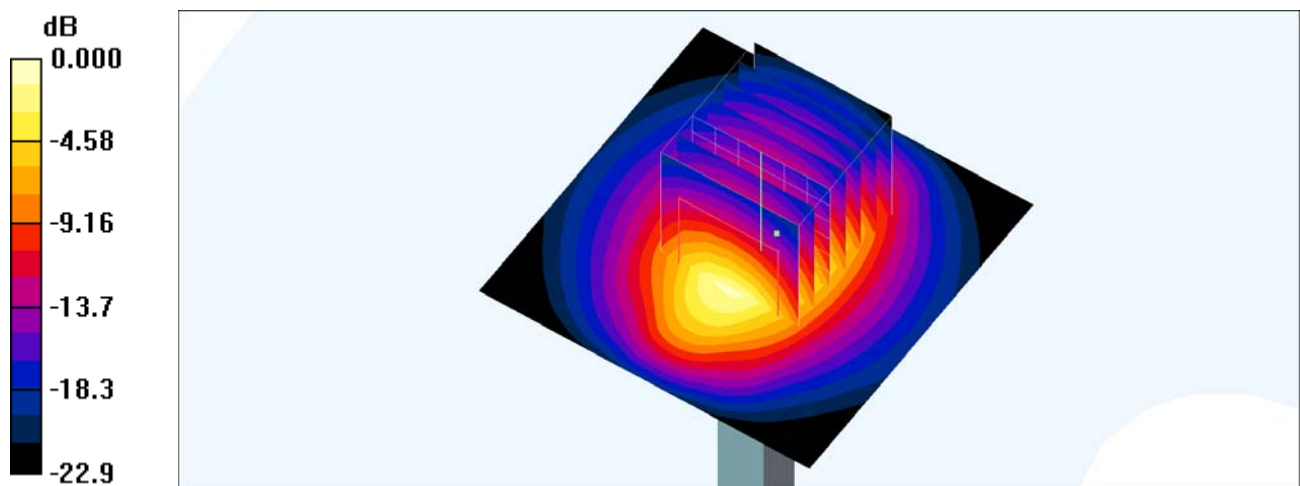

0 dB = 18.9mW/g

## System Check\_Body\_2450MHz

### DUT: D2450V2-926

Communication System: CW; Frequency: 2450 MHz; Duty Cycle: 1:1

Medium: MSL\_2450\_170527 Medium parameters used:  $f = 2450$  MHz;  $\sigma = 1.933$  S/m;  $\epsilon_r = 53.503$ ;

$\rho = 1000$  kg/m<sup>3</sup>

Ambient Temperature : 23.5 °C; Liquid Temperature : 22.5 °C

### DASY5 Configuration

- Probe: ES3DV3 - SN3169; ConvF(4.28, 4.28, 4.28); Calibrated: 2017/5/11;
- Sensor-Surface: 3mm (Mechanical Surface Detection)
- Electronics: DAE4 Sn853; Calibrated: 2016/7/11
- Phantom: SAM\_Right; Type: QD000P40CD; Serial: S/N:1801
- Measurement SW: DASY52, Version 52.8 (8); SEMCAD X Version 14.6.10 (7373)

**Pin=250mW/Area Scan (61x61x1):** Interpolated grid: dx=1.200 mm, dy=1.200 mm

Maximum value of SAR (interpolated) = 15.9 W/kg

**Pin=250mW/Zoom Scan (7x7x7)/Cube 0:** Measurement grid: dx=5mm, dy=5mm, dz=5mm

Reference Value = 94.10 V/m; Power Drift = -0.05 dB

Peak SAR (extrapolated) = 23.4 W/kg

**SAR(1 g) = 12 W/kg; SAR(10 g) = 5.68 W/kg**

Maximum value of SAR (measured) = 15.8 W/kg

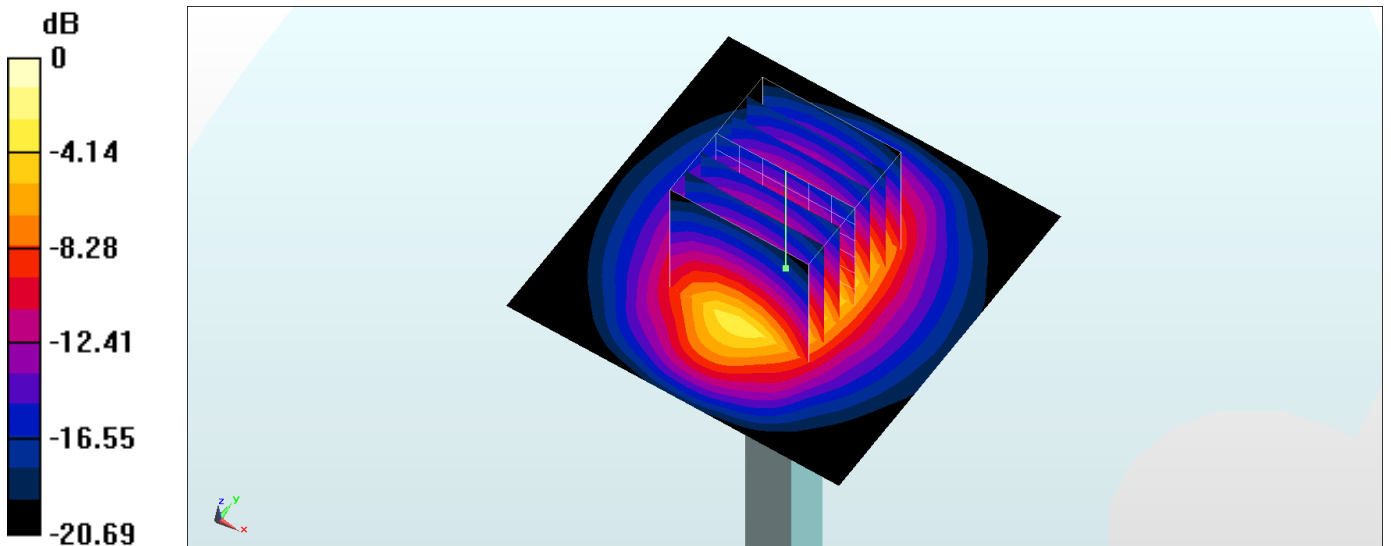

0 dB = 15.8 W/kg = 11.99 dBW/kg



## System Check\_Head\_5250MHz

### DUT: D5GHzV2-1006

Communication System: CW; Frequency: 5250 MHz; Duty Cycle: 1:1

Medium: HSL\_5G\_170520 Medium parameters used:  $f = 5250$  MHz;  $\sigma = 4.61$  mho/m;  $\epsilon_r = 36.8$ ;  $\rho = 1000$  kg/m<sup>3</sup>

Ambient Temperature : 23.3 °C; Liquid Temperature : 22.3 °C

#### DASY4 Configuration:

- Probe: EX3DV4 - SN3955; ConvF(5.04, 5.04, 5.04); Calibrated: 2016/11/24
- Sensor-Surface: 1.4mm (Mechanical Surface Detection)
- Electronics: DAE4 Sn1399; Calibrated: 2016/11/17
- Phantom: SAM\_Right; Type: QD000P40CD; Serial: TP:1815
- ;Postprocessing SW: SEMCAD, V1.8 Build 159

**Pin=100mW/Area Scan (71x71x1):** Measurement grid: dx=10mm, dy=10mm

Maximum value of SAR (interpolated) = 19.8 mW/g

**Pin=100mW/Zoom Scan (7x7x7)/Cube 0:** Measurement grid: dx=4mm, dy=4mm, dz=1.4mm

Reference Value = 72.5 V/m; Power Drift = 0.125 dB

Peak SAR (extrapolated) = 31.6 W/kg

**SAR(1 g) = 8.11 mW/g; SAR(10 g) = 2.24 mW/g**

Maximum value of SAR (measured) = 20.0 mW/g

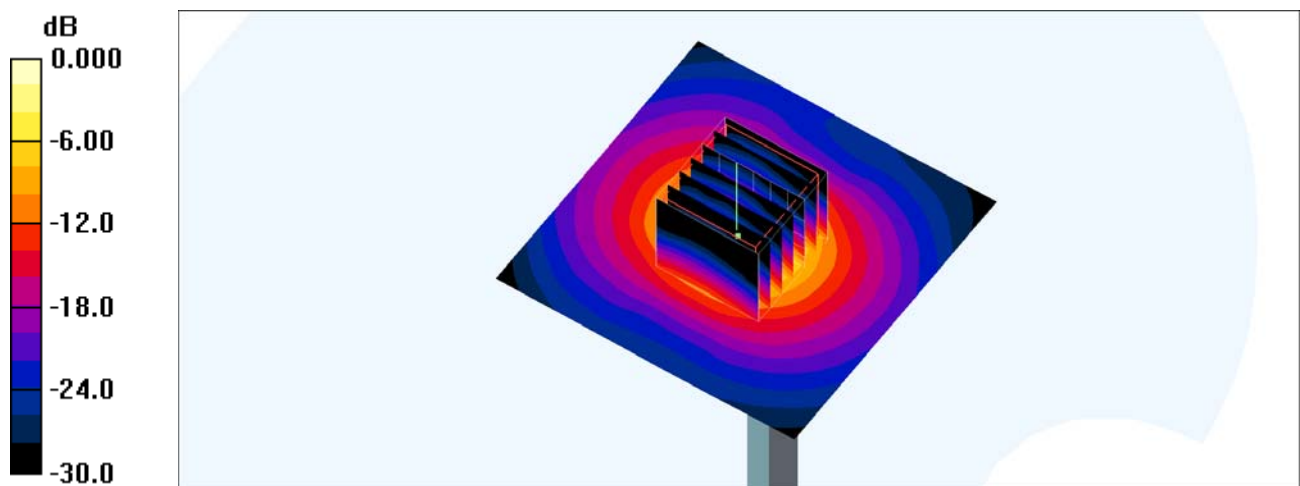

0 dB = 20.0mW/g

## System Check\_Body\_5250MHz

### DUT: D5GHzV2-1006

Communication System: CW; Frequency: 5250 MHz; Duty Cycle: 1:1

Medium: MSL\_5G\_170520 Medium parameters used:  $f = 5250$  MHz;  $\sigma = 5.41$  mho/m;  $\epsilon_r = 47.9$ ;  $\rho = 1000$  kg/m<sup>3</sup>

Ambient Temperature : 23.3 °C; Liquid Temperature : 22.3 °C

DASY4 Configuration:

- Probe: EX3DV4 - SN3955; ConvF(4.51, 4.51, 4.51); Calibrated: 2016/11/24
- Sensor-Surface: 1.4mm (Mechanical Surface Detection)
- Electronics: DAE4 Sn1399; Calibrated: 2016/11/17
- Phantom: SAM\_Right; Type: QD000P40CD; Serial: TP:1815
- ;Postprocessing SW: SEMCAD, V1.8 Build 159

**Pin=100mW/Area Scan (71x71x1):** Measurement grid: dx=10mm, dy=10mm

Maximum value of SAR (interpolated) = 17.2 mW/g

**Pin=100mW/Zoom Scan (7x7x7)/Cube 0:** Measurement grid: dx=4mm, dy=4mm, dz=1.4mm

Reference Value = 66.7 V/m; Power Drift = 0.123 dB

Peak SAR (extrapolated) = 28.9 W/kg

**SAR(1 g) = 7.35 mW/g; SAR(10 g) = 2.02 mW/g**

Maximum value of SAR (measured) = 17.9 mW/g

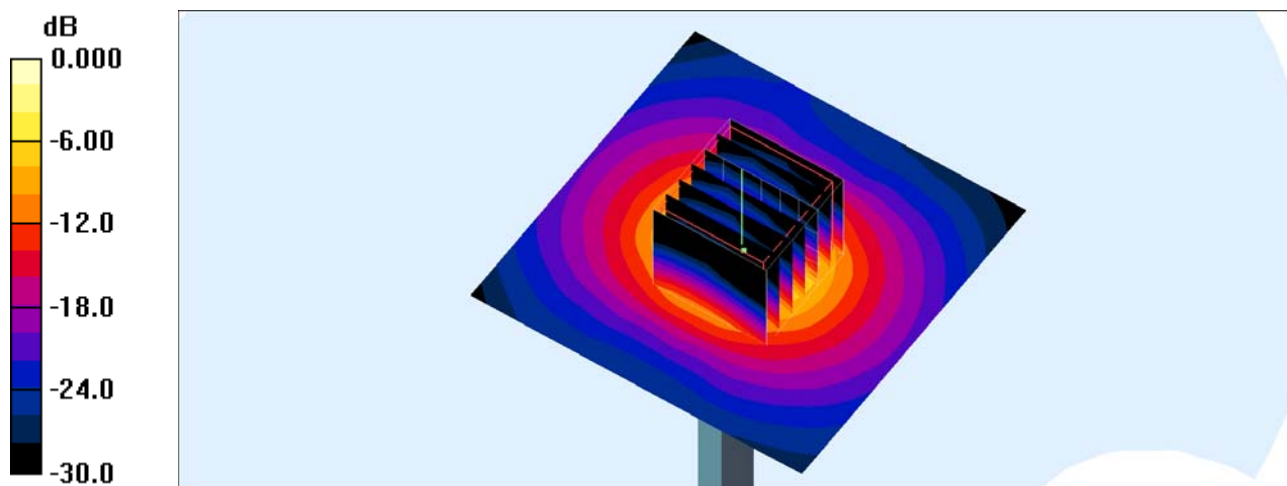

0 dB = 17.9mW/g

## System Check\_Head\_5600MHz

### DUT: D5GHzV2-1006

Communication System: CW; Frequency: 5600 MHz; Duty Cycle: 1:1

Medium: HSL\_5G\_170520 Medium parameters used:  $f = 5600$  MHz;  $\sigma = 4.97$  mho/m;  $\epsilon_r = 36.3$ ;  $\rho = 1000$  kg/m<sup>3</sup>

Ambient Temperature : 23.3 °C ; Liquid Temperature : 22.3 °C

#### DASY4 Configuration:

- Probe: EX3DV4 - SN3955; ConvF(4.5, 4.5, 4.5); Calibrated: 2016/11/24
- Sensor-Surface: 1.4mm (Mechanical Surface Detection)
- Electronics: DAE4 Sn1399; Calibrated: 2016/11/17
- Phantom: SAM\_Right; Type: QD000P40CD; Serial: TP:1815
- ;Postprocessing SW: SEMCAD, V1.8 Build 159

**Pin=100mW/Area Scan (71x71x1):** Measurement grid: dx=10mm, dy=10mm

Maximum value of SAR (interpolated) = 22.6 mW/g

**Pin=100mW/Zoom Scan (7x7x7)/Cube 0:** Measurement grid: dx=4mm, dy=4mm, dz=1.4mm

Reference Value = 76.0 V/m; Power Drift = 0.167 dB

Peak SAR (extrapolated) = 36.5 W/kg

**SAR(1 g) = 8.94 mW/g; SAR(10 g) = 2.45 mW/g**

Maximum value of SAR (measured) = 22.5 mW/g

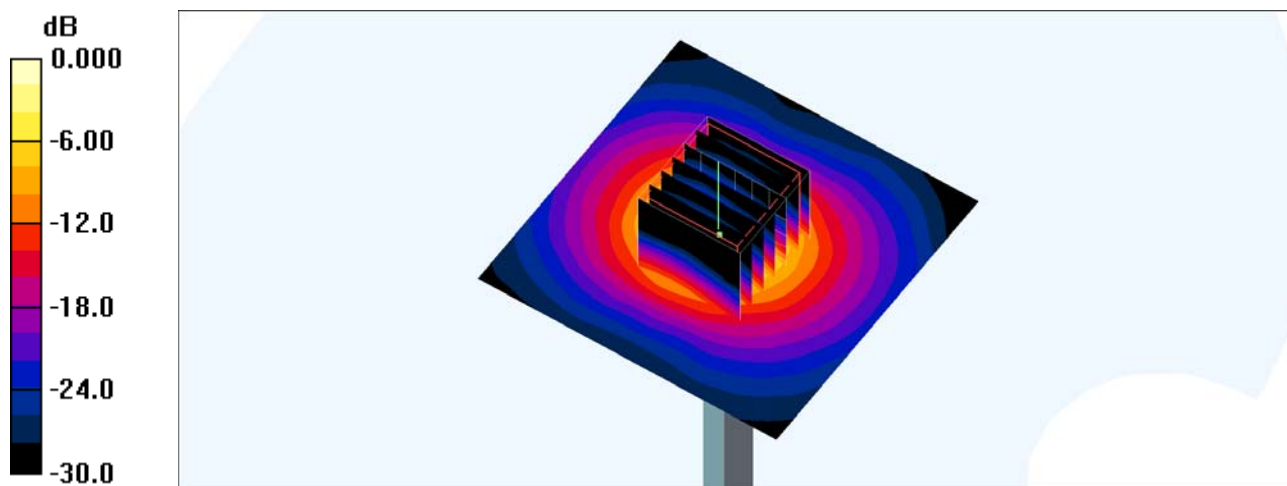

## System Check\_Body\_5600MHz

### DUT: D5GHzV2-1006

Communication System: CW; Frequency: 5600 MHz; Duty Cycle: 1:1

Medium: MSL\_5G\_170520 Medium parameters used:  $f = 5600$  MHz;  $\sigma = 5.87$  mho/m;  $\epsilon_r = 47.3$ ;  $\rho = 1000$  kg/m<sup>3</sup>

Ambient Temperature : 23.3 °C; Liquid Temperature : 22.3 °C

DASY4 Configuration:

- Probe: EX3DV4 - SN3955; ConvF(3.91, 3.91, 3.91); Calibrated: 2016/11/24
- Sensor-Surface: 1.4mm (Mechanical Surface Detection)
- Electronics: DAE4 Sn1399; Calibrated: 2016/11/17
- Phantom: SAM\_Right; Type: QD000P40CD; Serial: TP:1815
- ;Postprocessing SW: SEMCAD, V1.8 Build 159

**Pin=100mW/Area Scan (71x71x1):** Measurement grid: dx=10mm, dy=10mm

Maximum value of SAR (interpolated) = 19.2 mW/g

**Pin=100mW/Zoom Scan (7x7x7)/Cube 0:** Measurement grid: dx=4mm, dy=4mm, dz=1.4mm

Reference Value = 69.4 V/m; Power Drift = 0.151 dB

Peak SAR (extrapolated) = 36.0 W/kg

**SAR(1 g) = 8.48 mW/g; SAR(10 g) = 2.31 mW/g**

Maximum value of SAR (measured) = 21.4 mW/g

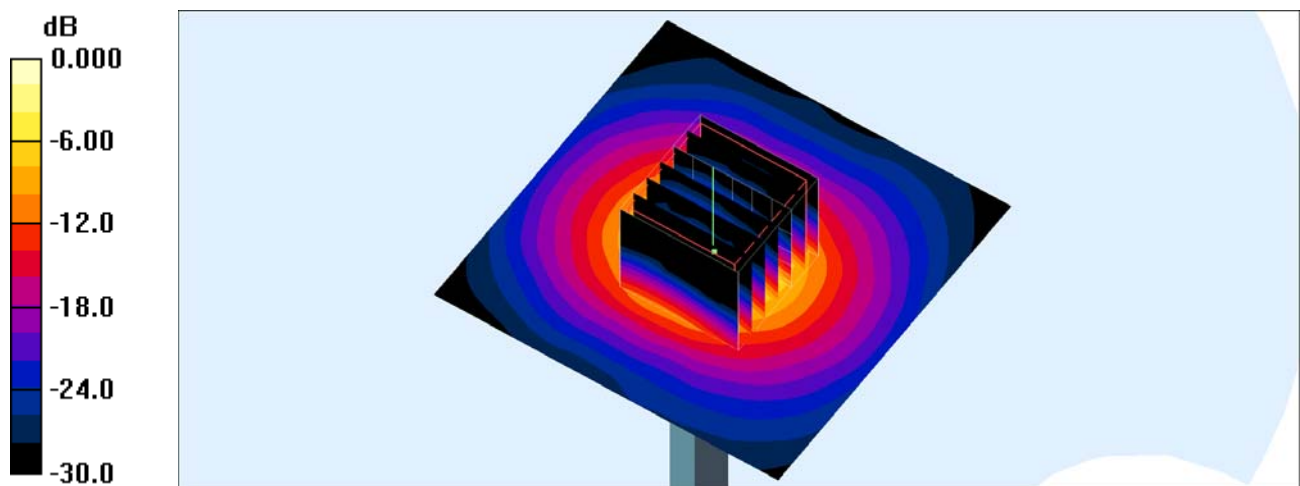

0 dB = 21.4mW/g