

FCC Measurement/Technical Report on

SARA-R410M-02B

FCC ID: XPY2AGQN4NNN

IC: 8595A-2AGQN4NNN

Test Report Reference: MDE_UBLOX_1907_FCCa

Test Laboratory:

7layers GmbH
Borsigstrasse 11
40880 Ratingen
Germany



Note:

The following test results relate only to the devices specified in this document. This report shall not be reproduced in parts without the written approval of the test laboratory.

7layers GmbH
Borsigstraße 11
40880 Ratingen, Germany
T +49 (0) 2102 749 0
F +49 (0) 2102 749 350

Geschäftsführer/
Managing Directors:
Frank Spiller
Bernhard Retka
Alexandre Norré-Oudard

Registergericht/registered:
Düsseldorf HRB 75554
USt-Id.-Nr./VAT-No. DE203159652
Steuer-Nr./TAX-No. 147/5869/0385

*a Bureau Veritas
Group Company*
www.7layers.com

Table of Contents

1	Applied Standards and Test Summary	3
1.1	Applied Standards	3
1.2	FCC-IC Correlation Table	4
1.3	Measurement Summary / Signatures	5
2	Revision History	9
3	Administrative Data	10
3.1	Testing Laboratory	10
3.2	Project Data	10
3.3	Applicant Data	10
3.4	Manufacturer Data	10
4	Test object Data	11
4.1	General EUT Description	11
4.2	EUT Main components	11
4.3	Ancillary Equipment	11
4.4	Auxiliary Equipment	11
4.5	EUT Setups	12
4.6	Operating Modes	12
4.7	Product labelling	12
5	Test Results	13
5.1	RF Output power § 2.1046 § 24.232	13
5.2	Frequency stability § 2.1055, § 24.235	17
5.3	Spurious emissions at antenna terminal § 2.1051 § 24.238	20
5.4	Field strength of spurious radiation § 2.1053, § 24.236	23
5.5	Emission and occupied bandwidth § 2.1049	30
5.6	Band edge compliance § 2.1051, § 24.238	35
5.7	Peak to Average Ratio § 24.232	38
6	Antenna Factors, Cable Loss and Sample Calculations	44
6.1	LISN R&S ESH3-Z5 (150 kHz – 30 MHz)	44
6.2	Antenna R&S HFH2-Z2 (9 kHz – 30 MHz)	45
6.3	Antenna R&S HL562 (30 MHz – 1 GHz)	46
6.4	Antenna R&S HF907 (1 GHz – 18 GHz)	47
6.5	Antenna EMCO 3160-09 (18 GHz – 26.5 GHz)	48
6.6	Antenna EMCO 3160-10 (26.5 GHz – 40 GHz)	49
7	Measurement Uncertainties	50
8	Photo Report	50

Applied Standards and Test Summary

1.1 APPLIED STANDARDS

Type of Authorization

Certification for an Industrial Signal Booster.

Applicable FCC Rules

Prepared in accordance with the requirements of FCC Rules and Regulations as listed in 47 CFR Ch.1 Parts 2 and 24, (10/1/18 Edition). The following subparts are applicable to the results in this test report.

Part 2, Subpart J - Equipment Authorization Procedures, Certification

Part 24, Subpart E – Broadband PCS

§ 24.232 – Power and antenna height limits

§ 24.235 – Frequency stability

§ 24.238 – Emission limitations for Broadband PCS equipment

The tests were selected and performed with reference to:

- FCC Public Notice 971168 applying “Measurement guidance for certification of licensed digital transmitters” 971168 D01 v03r01, 2018-04-09
- ANSI C63.26: 2015

Summary Test Results:

The EUT complied with all performed tests as listed in chapter 1.3 Measurement Summary / Signatures.

1.2 FCC-IC CORRELATION TABLE

FCC Rule / IC Standard	Part 22	RSS-132	Part 24	RSS-133	Part 27	RSS-139	RSS-130	RSS-199
		Issue 3, 2013		Issue 6, 2018		Issue 3, 2015	Issue 1, 2013	Issue 32016
Effective (isotropic) Radiated Power	§2.1046 §22.913	RSS-GEN 5, §6.12 RSS-132, §5.4	§2.1046 §24.232	RSS-GEN 5, §6.12 RSS-133, §6.4	§2.1046 §27.50	RSS-GEN 5, §6.12 RSS-139; §6.5	RSS-GEN 5, §6.12 RSS-130; §4.4	RSS-GEN 5, §6.12 RSS-199; §4.4
Emission and Occupied Bandwidth	§2.1049	RSS-GEN 5 §6.7	§2.1049	RSS-GEN 5 §6.7	§2.1049	RSS-GEN 5 §6.7	RSS-GEN 5 §6.7	RSS-GEN 5 §6.7
“Spuri” at Antenna Terminal	§2.1051 §22.917	RSS-GEN 5, §6.13 RSS-132, §5.5	§2.1051 §24.238	RSS-GEN 5, §6.13 RSS-133, §6.5	§2.1051 §27.53	RSS-GEN 5, §6.13 RSS-139, §6.6	RSS-GEN 5, §6.13 RSS-130, §4.6	RSS-GEN 5, §6.13 RSS-199, §4.5
Band Edge compliance	§2.1051 §22.917	RSS-GEN 5, §6.13	§2.1051 §24.238	RSS-GEN 5, §6.13	§2.1051 §27.53	RSS-GEN 5, §6.13	RSS-GEN 5, §6.13	RSS-GEN 5, §6.13
Frequency Stability	§2.1055 §22.355	RSS-GEN 5, §6.11 RSS-132, §5.3	§2.1055 §24.235	RSS-GEN 5, §6.11 RSS-133, §6.3	§2.1055 §27.51	RSS-GEN 5, §6.11 RSS-139, §6.4	RSS-GEN 5, §6.11 RSS-130, §4.3	RSS-GEN 5, §6.11 RSS-199, §4.3
Peak to Average Ratio	N/A	RSS-GEN 5, §6.12 RSS-132, §5.4	§2.1046 §24.232	RSS-GEN 5, §6.12 RSS-133, §6.4	§2.1046 §27.50	RSS-GEN 5, §6.12 RSS-139; §6.5	RSS-GEN 5, §6.12 RSS-130; §4.4	RSS-GEN 5, §6.12 RSS-199; §4.4
Field Strength of Spurious Radiation	§2.1053 §22.917	RSS-GEN 5, §6.13 RSS-132, §5.5	§2.1053 §24.235	RSS-GEN 5, §6.13 RSS-133, §6.5	§2.1053 §27.51	RSS-GEN 5, §6.13 RSS-139, §6.6	RSS-GEN 5, §6.13 RSS-130, §4.6	RSS-GEN 5, §6.13 RSS-199, §4.5

1.3 MEASUREMENT SUMMARY / SIGNATURES

47 CFR CHAPTER I FCC PART 24 Subpart E

§ 2.1046 § 24.232

RF Output power

§ 2.1046

§ 24.232

The measurement was performed according to ANSI C63.26: 2015

Final Result

OP-Mode

Radio Technology, Operating Frequency, ChBW, Ressource Blocks / Subcarrier, Measurement method

OP-Mode	Setup	FCC	IC
CAT-M1 eFDD 25 16QAM, high channel, 1.4 MHz, 1, conducted	S01_AB01	Passed	Passed
CAT-M1 eFDD 25 16QAM, high channel, 1.4 MHz, 5, conducted	S01_AB01	Passed	Passed
CAT-M1 eFDD 25 16QAM, low channel, 1.4 MHz, 1, conducted	S01_AB01	Passed	Passed
CAT-M1 eFDD 25 16QAM, low channel, 1.4 MHz, 5, conducted	S01_AB01	Passed	Passed
CAT-M1 eFDD 25 16QAM, mid channel, 1.4 MHz, 1, conducted	S01_AB01	Passed	Passed
CAT-M1 eFDD 25 16QAM, mid channel, 1.4 MHz, 5, conducted	S01_AB01	Passed	Passed
CAT-M1 eFDD 25 QPSK, high channel, 1.4 MHz, 1, conducted	S01_AB01	Passed	Passed
CAT-M1 eFDD 25 QPSK, high channel, 1.4 MHz, 3, conducted	S01_AB01	Passed	Passed
CAT-M1 eFDD 25 QPSK, high channel, 1.4 MHz, 6, conducted	S01_AB01	Passed	Passed
CAT-M1 eFDD 25 QPSK, low channel, 1.4 MHz, 1, conducted	S01_AB01	Passed	Passed
CAT-M1 eFDD 25 QPSK, low channel, 1.4 MHz, 3, conducted	S01_AB01	Passed	Passed
CAT-M1 eFDD 25 QPSK, low channel, 1.4 MHz, 6, conducted	S01_AB01	Passed	Passed
CAT-M1 eFDD 25 QPSK, mid channel, 1.4 MHz, 1, conducted	S01_AB01	Passed	Passed
CAT-M1 eFDD 25 QPSK, mid channel, 1.4 MHz, 3, conducted	S01_AB01	Passed	Passed
CAT-M1 eFDD 25 QPSK, mid channel, 1.4 MHz, 6, conducted	S01_AB01	Passed	Passed
NB-IoT eFDD 25 BPSK, high channel, 0.2 MHz, 1, conducted	S01_AB01	Passed	Passed
NB-IoT eFDD 25 BPSK, low channel, 0.2 MHz, 1, conducted	S01_AB01	Passed	Passed
NB-IoT eFDD 25 BPSK, mid channel, 0.2 MHz, 1, conducted	S01_AB01	Passed	Passed
NB-IoT eFDD 25 QPSK, high channel, 0.2 MHz, 1, conducted	S01_AB01	Passed	Passed
NB-IoT eFDD 25 QPSK, high channel, 0.2 MHz, 12, conducted	S01_AB01	Passed	Passed
NB-IoT eFDD 25 QPSK, high channel, 0.2 MHz, 3, conducted	S01_AB01	Passed	Passed
NB-IoT eFDD 25 QPSK, high channel, 0.2 MHz, 6, conducted	S01_AB01	Passed	Passed
NB-IoT eFDD 25 QPSK, low channel, 0.2 MHz, 1, conducted	S01_AB01	Passed	Passed
NB-IoT eFDD 25 QPSK, low channel, 0.2 MHz, 12, conducted	S01_AB01	Passed	Passed
NB-IoT eFDD 25 QPSK, low channel, 0.2 MHz, 3, conducted	S01_AB01	Passed	Passed
NB-IoT eFDD 25 QPSK, low channel, 0.2 MHz, 6, conducted	S01_AB01	Passed	Passed
NB-IoT eFDD 25 QPSK, mid channel, 0.2 MHz, 1, conducted	S01_AB01	Passed	Passed
NB-IoT eFDD 25 QPSK, mid channel, 0.2 MHz, 12, conducted	S01_AB01	Passed	Passed
NB-IoT eFDD 25 QPSK, mid channel, 0.2 MHz, 3, conducted	S01_AB01	Passed	Passed
NB-IoT eFDD 25 QPSK, mid channel, 0.2 MHz, 6, conducted	S01_AB01	Passed	Passed

47 CFR CHAPTER I FCC PART 24 Subpart E § 2.1055 § 24.235

Frequency stability § 2.1055, § 24.235

The measurement was performed according to ANSI C63.26: 2015

Final Result

OP-Mode	Setup	FCC	IC
Radio Technology, Operating Frequency, ChBW, Ressource Blocks / Subcarrier, Measurement method			
CAT-M1 eFDD 25 QPSK, mid channel, 1.4 MHz, 1, conducted	S01_AB01	Passed	Passed
NB-IoT eFDD 25 QPSK, mid channel, 0.2 MHz, 1, conducted	S01_AB01	Passed	Passed

47 CFR CHAPTER I FCC PART 24 Subpart E § 2.1051 § 24.238

Spurious emissions at antenna terminal

§ 2.1051

§ 24.238

The measurement was performed according to ANSI C63.26: 2015

Final Result

OP-Mode	Setup	FCC	IC
Radio Technology, Operating Frequency, ChBW, Ressource Blocks / Subcarrier, Measurement method			
CAT-M1 eFDD 25 QPSK, high channel, 1.4 MHz, 1, conducted	S01_AB01	Passed	Passed
CAT-M1 eFDD 25 QPSK, low channel, 1.4 MHz, 1, conducted	S01_AB01	Passed	Passed
CAT-M1 eFDD 25 QPSK, mid channel, 1.4 MHz, 1, conducted	S01_AB01	Passed	Passed
NB-IoT eFDD 25 QPSK, high channel, 0.2 MHz, 1, conducted	S01_AB01	Passed	Passed
NB-IoT eFDD 25 QPSK, low channel, 0.2 MHz, 1, conducted	S01_AB01	Passed	Passed
NB-IoT eFDD 25 QPSK, mid channel, 0.2 MHz, 1, conducted	S01_AB01	Passed	Passed

47 CFR CHAPTER I FCC PART 24 Subpart E § 2.1053 § 24.236

Field strength of spurious radiation § 2.1053, § 24.236

The measurement was performed according to ANSI C63.26: 2015

Final Result

OP-Mode	Setup	FCC	IC
Radio Technology, Operating Frequency, ChBW, Ressource Blocks / Subcarrier, Measurement method			
CAT-M1 eFDD 25 QPSK, high channel, 1.4 MHz, 1, radiated	S01_AB01	Passed	Passed
CAT-M1 eFDD 25 QPSK, low channel, 1.4 MHz, 1, radiated	S01_AB01	Passed	Passed
CAT-M1 eFDD 25 QPSK, mid channel, 1.4 MHz, 1, radiated	S01_AB01	Passed	Passed
NB-IoT eFDD 25 QPSK, high channel, 0.2 MHz, 1, radiated	S01_AB01	Passed	Passed
NB-IoT eFDD 25 QPSK, low channel, 0.2 MHz, 1, radiated	S01_AB01	Passed	Passed
NB-IoT eFDD 25 QPSK, mid channel, 0.2 MHz, 1, radiated	S01_AB01	Passed	Passed

47 CFR CHAPTER I FCC PART 24 Subpart E § 2.1049

Emission and occupied bandwidth

§ 2.1049

The measurement was performed according to ANSI C63.26: 2015

Final Result

OP-Mode	Setup	FCC	IC
Radio Technology, Operating Frequency, ChBW, Ressource Blocks, Measurement method			
CAT-M1 eFDD 25 16QAM, high channel, 1.4 MHz, 5, conducted	S01_AB01	Passed	Passed

47 CFR CHAPTER I FCC PART 24 Subpart E § 2.1049

Emission and occupied bandwidth

§ 2.1049

The measurement was performed according to ANSI C63.26: 2015

Final Result

OP-Mode	Setup	FCC	IC
Radio Technology, Operating Frequency, ChBW, Ressource Blocks, Measurement method			
CAT-M1 eFDD 25 16QAM, low channel, 1.4 MHz, 5, conducted	S01_AB01	Passed	Passed
CAT-M1 eFDD 25 16QAM, mid channel, 1.4 MHz, 5, conducted	S01_AB01	Passed	Passed
CAT-M1 eFDD 25 QPSK, high channel, 1.4 MHz, 6, conducted	S01_AB01	Passed	Passed
CAT-M1 eFDD 25 QPSK, low channel, 1.4 MHz, 6, conducted	S01_AB01	Passed	Passed
CAT-M1 eFDD 25 QPSK, mid channel, 1.4 MHz, 6, conducted	S01_AB01	Passed	Passed
NB-IoT eFDD 25 BPSK, high channel, 0.2 MHz, 1, conducted	S01_AB01	Passed	Passed
NB-IoT eFDD 25 BPSK, low channel, 0.2 MHz, 1, conducted	S01_AB01	Passed	Passed
NB-IoT eFDD 25 BPSK, mid channel, 0.2 MHz, 1, conducted	S01_AB01	Passed	Passed
NB-IoT eFDD 25 QPSK, high channel, 0.2 MHz, 12, conducted	S01_AB01	Passed	Passed
NB-IoT eFDD 25 QPSK, low channel, 0.2 MHz, 12, conducted	S01_AB01	Passed	Passed
NB-IoT eFDD 25 QPSK, mid channel, 0.2 MHz, 12, conducted	S01_AB01	Passed	Passed

47 CFR CHAPTER I FCC PART 24 Subpart E § 2.1051 § 24.238

Band edge compliance § 2.1051, § 24.238

The measurement was performed according to ANSI C63.26: 2015

Final Result

OP-Mode	Setup	FCC	IC
Radio Technology, Operating Frequency, ChBW, Ressource Blocks / Subcarrier, Measurement method			
CAT-M1 eFDD 25 16QAM, high channel, 1.4 MHz, 5, conducted	S01_AB01	Passed	Passed
CAT-M1 eFDD 25 16QAM, low channel, 1.4 MHz, 5, conducted	S01_AB01	Passed	Passed
CAT-M1 eFDD 25 QPSK, high channel, 1.4 MHz, 6, conducted	S01_AB01	Passed	Passed
CAT-M1 eFDD 25 QPSK, low channel, 1.4 MHz, 6, conducted	S01_AB01	Passed	Passed
NB-IoT eFDD 25 BPSK, high channel, 0.2 MHz, 1, conducted	S01_AB01	Passed	Passed
NB-IoT eFDD 25 BPSK, low channel, 0.2 MHz, 1, conducted	S01_AB01	Passed	Passed
NB-IoT eFDD 25 QPSK, high channel, 0.2 MHz, 12, conducted	S01_AB01	Passed	Passed
NB-IoT eFDD 25 QPSK, low channel, 0.2 MHz, 12, conducted	S01_AB01	Passed	Passed

47 CFR CHAPTER I FCC PART 24 Subpart E § 24.232

Peak to Average Ratio § 24.232

The measurement was performed according to ANSI C63.26: 2015

Final Result

OP-Mode	Setup	FCC	IC
Radio Technology, Operating Frequency, ChBW, Ressource Blocks / Subcarrier, Measurement method			
CAT-M1 eFDD 25 16QAM, high channel, 1.4 MHz, 5, conducted	S01_AB01	Passed	Passed
CAT-M1 eFDD 25 16QAM, low channel, 1.4 MHz, 5, conducted	S01_AB01	Passed	Passed
CAT-M1 eFDD 25 16QAM, mid channel, 1.4 MHz, 5, conducted	S01_AB01	Passed	Passed
CAT-M1 eFDD 25 QPSK, high channel, 1.4 MHz, 6, conducted	S01_AB01	Passed	Passed
CAT-M1 eFDD 25 QPSK, low channel, 1.4 MHz, 6, conducted	S01_AB01	Passed	Passed
CAT-M1 eFDD 25 QPSK, mid channel, 1.4 MHz, 6, conducted	S01_AB01	Passed	Passed

47 CFR CHAPTER I FCC PART 24 Subpart E

§ 24.232

Peak to Average Ratio § 24.232

The measurement was performed according to ANSI C63.26: 2015

Final Result

OP-Mode

Radio Technology, Operating Frequency, ChBW, Ressource Blocks / Subcarrier, Measurement method

Setup

FCC

IC

NB-IoT eFDD 25 BPSK, high channel, 0.2 MHz, 1, conducted	S01_AB01	Passed	Passed
NB-IoT eFDD 25 BPSK, low channel, 0.2 MHz, 1, conducted	S01_AB01	Passed	Passed
NB-IoT eFDD 25 BPSK, mid channel, 0.2 MHz, 1, conducted	S01_AB01	Passed	Passed
NB-IoT eFDD 25 QPSK, high channel, 0.2 MHz, 12, conducted	S01_AB01	Passed	Passed
NB-IoT eFDD 25 QPSK, low channel, 0.2 MHz, 12, conducted	S01_AB01	Passed	Passed
NB-IoT eFDD 25 QPSK, mid channel, 0.2 MHz, 12, conducted	S01_AB01	Passed	Passed

N/A: Not applicable

N/P: Not performed

2 REVISION HISTORY

Report version control			
Version	Release date	Change Description	Version validity
initial	2019-03-25	--	valid
--	--	--	--

COMMENT: -

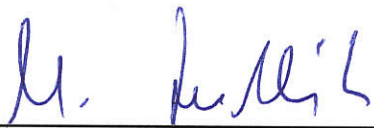

(responsible for accreditation scope)
Dipl.-Ing. Marco Kullik

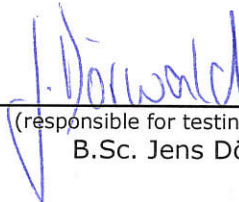

(responsible for testing and report)
B.Sc. Jens Dörwald



7 layers GmbH, Borsigstr. 11
40880 Ratingen, Germany
Phone +49 (0)2102 749 0

3 ADMINISTRATIVE DATA

3.1 TESTING LABORATORY

Company Name: 7layers GmbH
Address: Borsigstr. 11
40880 Ratingen
Germany

The test facility is accredited by the following accreditation organisation:

Laboratory accreditation no: DAkkS D-PL-12140-01-00
FCC Designation Number: DE0015
FCC Test Firm Registration: 929146
ISED CAB Identifier: DE0007; ISED#: 3699A
Responsible for accreditation scope: Dipl.-Ing. Marco Kullik
Report Template Version: 2019-02-12

3.2 PROJECT DATA

Responsible for testing and report: B.Sc. Jens Dörwald
Employees who performed the tests: documented internally at 7Layers
Date of Report: 2019-04-03
Testing Period: 2019-03-19 to 2019-03-24

3.3 APPLICANT DATA

Company Name: u-blox AG
Address: Zürcherstrasse 68, 8800 Thalwil
Switzerland
Contact Person: Mr. Giulio Comar

3.4 MANUFACTURER DATA

Company Name: please see Applicant Data
Address:
Contact Person:

4 TEST OBJECT DATA

4.1 GENERAL EUT DESCRIPTION

Kind of Device product description	CAT-M1 & NB-IoT Cellular Module
Product name	SARA-R410M-02B
Type	-
Declared EUT data by the supplier	
General product description	CAT-M1 & NB-IoT Cellular Module
Voltage Level	3.8 V
Voltage Type	DC

The main components of the EUT are listed and described in chapter 3.2 EUT Main components.

4.2 EUT MAIN COMPONENTS

Sample Name	Sample Code	Description
DE1015106	ab01	
Sample Parameter	Value	
Serial No.	352753094745070	
HW Version	306A06	
SW Version	L0.0.00.00.05.06	
Comment	-	

NOTE: The short description is used to simplify the identification of the EUT in this test report.

4.3 ANCILLARY EQUIPMENT

For the purposes of this test report, ancillary equipment is defined as equipment which is used in conjunction with the EUT to provide operational and control features to the EUT. It is necessary to configure the system in a typical fashion, as a customer would normally use it. But nevertheless Ancillary Equipment can influence the test results.

Device	Details (Manufacturer, Type Model, OUT Code)	Description
-	-	-

4.4 AUXILIARY EQUIPMENT

For the purposes of this test report, auxiliary equipment is defined as equipment which is used temporarily to enable operational and control features especially used for the tests of the EUT which is not used during normal operation or equipment that is used during the tests in

combination with the EUT but is not subject of this test report. It is necessary to configure the system in a typical fashion, as a customer would normally use it. But nevertheless Auxiliary Equipment can influence the test results.

Device	Details (Manufacturer, Type Model, HW, SW, S/N)	Description
-	-	-

4.5 EUT SETUPS

This chapter describes the combination of EUTs and equipment used for testing. The rationale for selecting the EUTs, ancillary and auxiliary equipment and interconnecting cables, is to test a representative configuration meeting the requirements of the referenced standards.

Setup	Combination of EUTs	Description and Rationale
S01_AB01	ab01	radiated & conducted sample

4.6 OPERATING MODES

This chapter describes the operating modes of the EUTs used for testing.

4.6.1 TEST CHANNELS

- CAT-M1 eFDD 25 Channel low = 26047 (1850.7 MHz)
- CAT-M1 eFDD 25 Channel mid = 26365 (1882.5 MHz)
- CAT-M1 eFDD 25 Channel high = 26683 (11914.3 MHz)
- NB-IoT eFDD 25 Channel low = 26041 (1850.1 MHz)
- NB-IoT eFDD 25 Channel mid = 26365 (1882.5 MHz)
- NB-IoT eFDD 25 Channel high = 26689 (1914.9 MHz)

4.7 PRODUCT LABELLING

4.7.1 FCC ID LABEL

Please refer to the documentation of the applicant.

4.7.2 LOCATION OF THE LABEL ON THE EUT

Please refer to the documentation of the applicant.

5 TEST RESULTS

5.1 RF OUTPUT POWER

Standard 47 CFR CHAPTER I FCC PART 24 SUBPART B

The test was performed according to:

ANSI C63.26: 2015

5.1.1 TEST DESCRIPTION

This test case is intended to demonstrate compliance to the applicable RF Output power test case per § 2.1046 and RSS-GEN 6.12. The limit and the requirements come from the applicable rule part and ISED RSS-Standard for the operating band of the cellular device.

The EUT was connected to the test setup according to the following diagram:

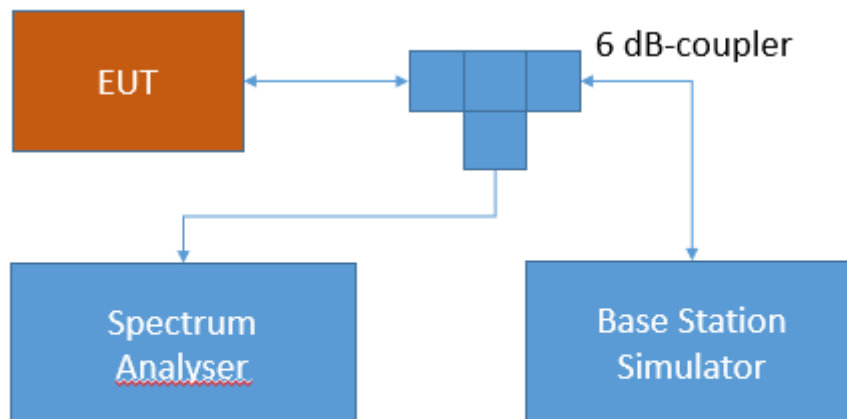

Test Setup FCC Part 22/24/27/90 Cellular;
RF Output power

The attenuation of the measuring and stimulus path are known for each measured frequency and are considered.

The Spectrum Analyzer settings can be directly found in the measurement diagrams.

5.1.2 TEST REQUIREMENTS / LIMITS

FCC Part 24, § 24.232

(c) Mobile and portable stations are limited to 2 watts EIRP and the equipment must employ a means for limiting power to the minimum necessary for successful communications.

RSS-133; 6.4 Transmitter Output Power and Equivalent Isotropically Radiated Power

The equivalent isotropically radiated power (e.i.r.p.) for transmitters shall not exceed the limits given in SRSP-510.

SRSP-510; 5.1.2 Radiated Power and Antenna Height Limits – Mobile Stations

Mobile stations and hand-held portables are limited to 2 watts maximum e.i.r.p. The equipment shall employ means to limit the power to the minimum necessary for successful communication.

5.1.3 TEST PROTOCOL

Ambient temperature: 23 °C
Relative humidity: 34 %

Radio Technology	Channel	Ressource Blocks / Subcarrier	Bandwidth [MHz]	RMS Conducted Power [dBm]	FCC EIRP Limit [W]	IC EIRP Limit [W]	Maximum Antenna Gain FCC [dBi]	Maximum Antenna Gain IC [dBi]
CAT-M1 eFDD 25 QPSK	low	1	1.4	22.2	2	2	10.8	10.8
CAT-M1 eFDD 25 QPSK	low	3	1.4	21.2	2	2	11.8	11.8
CAT-M1 eFDD 25 QPSK	low	6	1.4	20.3	2	2	12.7	12.7
CAT-M1 eFDD 25 QPSK	mid	1	1.4	22.57	2	2	10.43	10.43
CAT-M1 eFDD 25 QPSK	mid	3	1.4	21.32	2	2	11.68	11.68
CAT-M1 eFDD 25 QPSK	mid	6	1.4	20.46	2	2	12.54	12.54
CAT-M1 eFDD 25 QPSK	high	1	1.4	22.44	2	2	10.56	10.56
CAT-M1 eFDD 25 QPSK	high	3	1.4	21.26	2	2	11.74	11.74
CAT-M1 eFDD 25 QPSK	high	6	1.4	20.17	2	2	12.83	12.83
CAT-M1 eFDD 25 16QAM	low	1	1.4	21.37	2	2	11.63	11.63
CAT-M1 eFDD 25 16QAM	low	5	1.4	20.45	2	2	12.55	12.55
CAT-M1 eFDD 25 16QAM	mid	1	1.4	21.7	2	2	11.3	11.3
CAT-M1 eFDD 25 16QAM	mid	5	1.4	20.52	2	2	12.48	12.48
CAT-M1 eFDD 25 16QAM	high	1	1.4	21.42	2	2	11.58	11.58
CAT-M1 eFDD 25 16QAM	high	5	1.4	20.06	2	2	12.94	12.94
NB-IoT eFDD 25 QPSK	low	1	0.2	23.03	2	2	9.97	9.97
NB-IoT eFDD 25 QPSK	low	3	0.2	22.61	2	2	10.39	10.39
NB-IoT eFDD 25 QPSK	low	6	0.2	22.1	2	2	10.9	10.9
NB-IoT eFDD 25 QPSK	low	12	0.2	20.84	2	2	12.16	12.16
NB-IoT eFDD 25 QPSK	mid	1	0.2	23.07	2	2	9.93	9.93
NB-IoT eFDD 25 QPSK	mid	3	0.2	22.83	2	2	10.17	10.17
NB-IoT eFDD 25 QPSK	mid	6	0.2	22.5	2	2	10.5	10.5
NB-IoT eFDD 25 QPSK	mid	12	0.2	20.81	2	2	12.19	12.19
NB-IoT eFDD 25 QPSK	high	1	0.2	22.94	2	2	10.06	10.06
NB-IoT eFDD 25 QPSK	high	3	0.2	22.65	2	2	10.35	10.35
NB-IoT eFDD 25 QPSK	high	6	0.2	22.22	2	2	10.78	10.78
NB-IoT eFDD 25 QPSK	high	12	0.2	20.23	2	2	12.77	12.77
NB-IoT eFDD 25 BPSK	low	1	0.2	23.79	2	2	9.21	9.21
NB-IoT eFDD 25 BPSK	mid	1	0.2	23.58	2	2	9.42	9.42
NB-IoT eFDD 25 BPSK	high	1	0.2	23.76	2	2	9.24	9.24

Remark: Please see next sub-clause for the measurement plot.

5.1.4 MEASUREMENT PLOT (SHOWING THE HIGHEST VALUE, "WORST CASE")

CAT-M1 eFDD 25 QPSK, CH-MID, RB=1

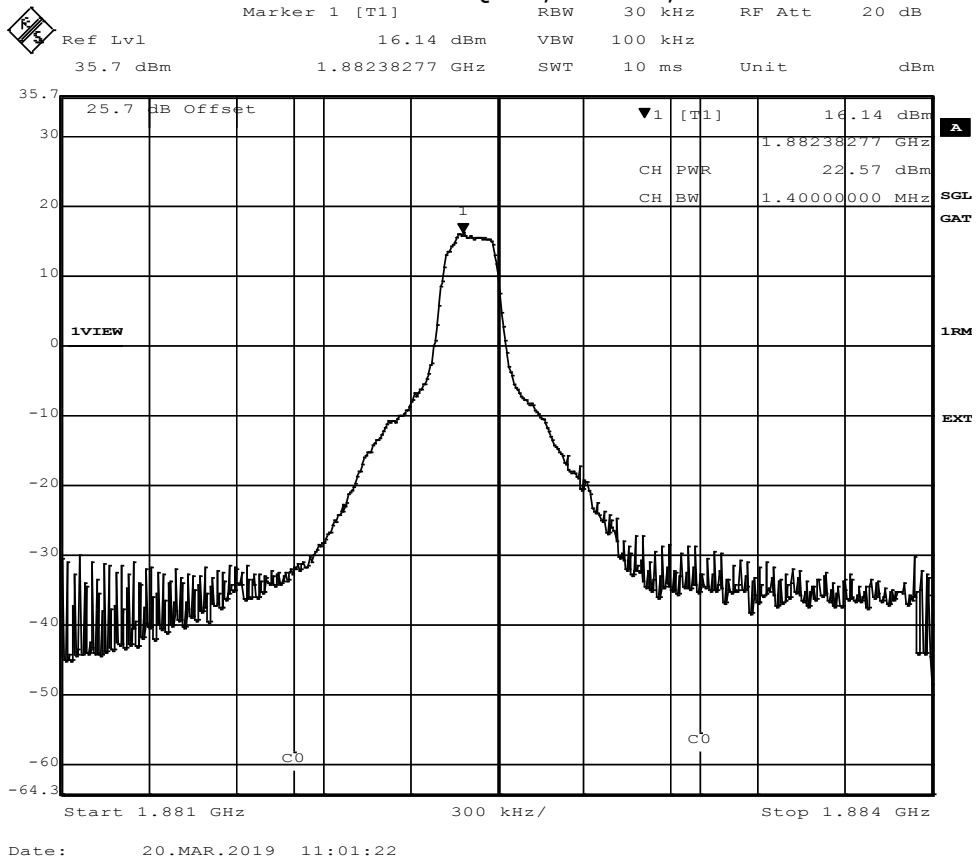

NB-IoT eFDD25 BPSK, SUBCARRIER = 1, CH=LOW

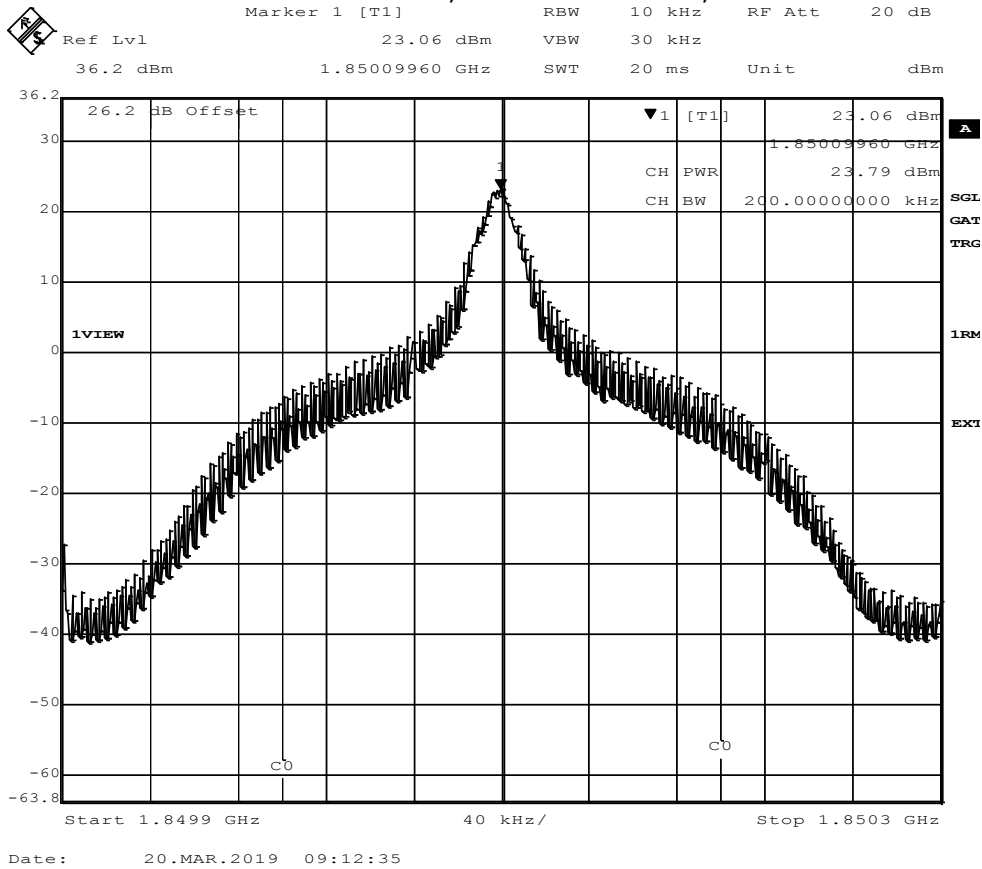

5.1.5 TEST EQUIPMENT USED

- Radio Lab

5.2 FREQUENCY STABILITY

Standard 47 CFR CHAPTER I FCC PART 24 SUBPART B

The test was performed according to:
ANSI C63.26: 2015

5.2.1 TEST DESCRIPTION

This test case is intended to demonstrate compliance to the applicable frequency stability test case per § 2.1055 and RSS-GEN 6.11. The limit and the requirements come from the applicable rule part and ISED RSS-Standard for the operating band of the cellular device.

The EUT was connected to the test setup according to the following diagram:



Test Setup FCC Part 22/24/27/90 Cellular;
Frequency stability

The attenuation of the measuring / stimulus path is known for each measured frequency and are considered.

5.2.2 TEST REQUIREMENTS / LIMITS

FCC Part 24, § 24.235

The frequency stability shall be sufficient to ensure that the fundamental emission stays within the authorized frequency block.

RSS-133; 6.3 Frequency Stability

The carrier frequency shall not depart from the reference frequency, in excess of ± 2.5 ppm for mobile stations.

In lieu of meeting the above stability values, the test report may show that the frequency stability is sufficient to ensure that the emission bandwidth stays within the operating frequency block when tested to the temperature and supply voltage variations specified in RSS-Gen.

5.2.3 TEST PROTOCOL

Ambient temperature: 23 °C
 Relative humidity: 34 %

CAT-M1 eFDD25

Temp. °C	Duration min	Voltage	Limit Hz	Freq. error Average (Hz)	Freq. error Max. (Hz)	Verdict
-30	0	normal	1955	2.1	8.4	passed
-30	5			2.6	7.6	passed
-30	10			-2.4	-5.4	passed
-20	0	normal	1955	-1.9	7.3	passed
-20	5			-1.5	-9.4	passed
-20	10			-2.3	-9.2	passed
-10	0	normal	1955	-1.6	8.4	passed
-10	5			2.2	8.3	passed
-10	10			2.7	7.1	passed
0	0	normal	1955	1.7	-11.2	passed
0	5			-1.3	-10.6	passed
0	10			-1.8	-8.3	passed
10	0	normal	1955	2.4	-6.4	passed
10	5			-2.6	-7.2	passed
10	10			-1.5	8.5	passed
20	0	low	1955	1.6	-9.3	passed
20	5			1.8	-9.4	passed
20	10			1.9	-10.1	passed
20	0	normal = high ¹⁾	1955	1.7	-6.8	passed
20	5			-1.2	-6.4	passed
20	10			-2.3	4.6	passed
20	0	high	1955	2.8	-7.4	passed
20	5			1.6	-8.3	passed
20	10			1.9	-8.1	passed
30	0	normal	1955	-2.3	-6.8	passed
30	5			-2.4	-7.7	passed
30	10			-1.7	-11.4	passed
40	0	normal	1955	-1.9	-7.6	passed
40	5			1.4	8.7	passed
40	10			1	8.5	passed
50	0	normal	1955	2.3	7.9	passed
50	5			2.7	-4.8	passed
50	10			2.4	-5.6	passed

NB-IoT eFDD25

Temp. °C	Duration min	Voltage	Limit Hz	Freq. error Average (Hz)	Freq. error Max. (Hz)	Verdict
-30	0	normal	1955	-1.3	-6.2	passed
-30	5			-0.9	-7.3	passed
-30	10			-1.5	-6.4	passed
-20	0	normal	1955	-2	-7.1	passed
-20	5			-1.9	-7.3	passed
-20	10			-2.2	-8.4	passed
-10	0	normal	1955	-1.2	-7.4	passed
-10	5			-1.6	-6.3	passed
-10	10			-1.7	-7.5	passed
0	0	normal	1955	-1.6	-6.8	passed
0	5			-2.3	-8.2	passed
0	10			-1.2	-7.3	passed
10	0	normal	1955	-2.1	-7.5	passed
10	5			-1.4	-7.6	passed
10	10			-1.6	-7.9	passed
20	0	low	1955	-0.9	-6.9	passed
20	5			-1.2	-7.4	passed
20	10			-1.3	-7.6	passed
20	0	high	1955	-1	-6.9	passed
20	5			-1.5	-7.1	passed
20	10			-1.8	-8.2	passed
20	0	high	1955	-1.4	-7.6	passed
20	5			-2.3	-7.3	passed
20	10			-2.4	-7.5	passed
30	0	normal	1955	-1.6	-8.3	passed
30	5			-1.8	-9.1	passed
30	10			-1.7	-6.8	passed
40	0	normal	1955	-1.4	-8.4	passed
40	5			-1.3	-7.8	passed
40	10			-1.7	-7.9	passed
50	0	normal	1955	-1.6	-11.2	passed
50	5			-1.4	-7.9	passed
50	10			-1.6	-7.3	passed

5.2.4 TEST EQUIPMENT USED

- Radio Lab

5.3 SPURIOUS EMISSIONS AT ANTENNA TERMINAL

Standard 47 CFR CHAPTER I FCC PART 24 SUBPART B

The test was performed according to:
ANSI C63.26: 2015

5.3.1 TEST DESCRIPTION

This test case is intended to demonstrate compliance to the applicable conducted spurious emission test case per § 2.1051 and RSS-GEN 6.13. The limit comes from the applicable rule part and ISSED RSS-Standard for the operating band of the cellular device.

The EUT was connected to the test setup according to the following diagram:

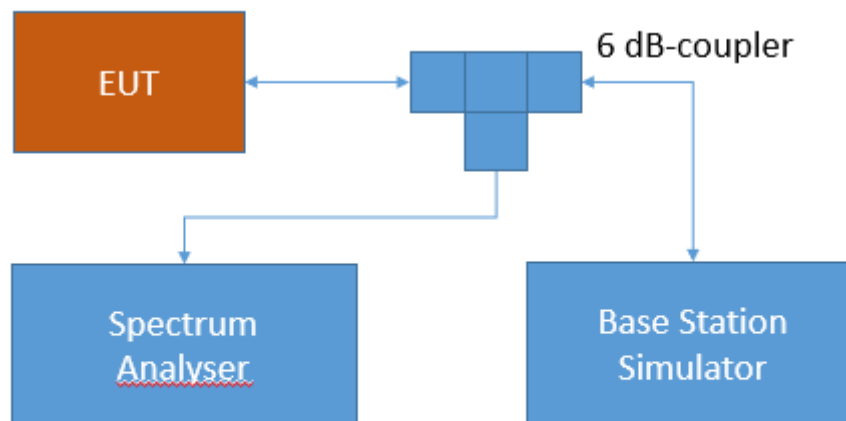

Test Setup FCC Part 22/24/27/90 Cellular;
Spurious Emissions at antenna terminal

The attenuation of the measuring and stimulus path are known for each measured frequency and are considered.

The Spectrum Analyser settings can be directly found in the measurement diagrams.

5.3.2 TEST REQUIREMENTS / LIMITS

FCC Part 2.1051; Measurement required: Spurious emissions at antenna terminal:

The radio frequency voltage or powers generated within the equipment and appearing on a spurious frequency shall be checked at the equipment output terminals when properly loaded with a suitable artificial antenna. Curves or equivalent data shall show the magnitude of each harmonic and other spurious emission that can be detected when the equipment is operated

under the conditions specified in §2.1049 as appropriate. The magnitude of spurious emissions which are attenuated more than 20 dB below the permissible value need not be specified.

Part 24, Subpart E – Broadband PCS; Band 2

§24.238 – Emission limitations for Broadband PCS equipment

(a) *Out of band emissions.* The power of any emission outside of the authorized operating frequency ranges must be attenuated below the transmitting power (P) by a factor of at least $43 + 10 \log(P)$ dB.

RSS-133; 6.5 Transmitter Unwanted Emissions

6.5.1 Out-of-Block Emissions

Equipment shall comply with the limits in (i) and (ii) below.

- i. In the 1.0 MHz bands immediately outside and adjacent to the equipment’s operating frequency block, the emission power per any 1% of the emission bandwidth shall be attenuated (in dB) below the transmitter output power P (dBW) by at least $43 + 10 \log_{10}(P)$ (watts).
- ii. After the first 1.0 MHz, the emission power in any 1 MHz bandwidth shall be attenuated (in dB) below the transmitter output power P (dBW) by at least $43 + 10 \log_{10}(P)$ (watts). If the measurement is performed using 1% of the emission bandwidth, power integration over 1.0 MHz is required.

5.3.3 TEST PROTOCOL

Ambient temperature: 23 °C Relative humidity: 34 %

Radio Technology	Channel	Detector	Trace	Resolution Bandwidth /kHz	Frequency /MHz	Peak Value /dBm	Limit /dBm	Margin to Limit /dB
CAT-M1 eFDD 25 QPSK	low	rms	maxhold	5	1850	-37.09	-17.5	19.59
CAT-M1 eFDD 25 QPSK	mid	rms	maxhold	-	-	-	-	-
CAT-M1 eFDD 25 QPSK	high	rms	maxhold	5	1915	-37.88	-17.5	20.38

Radio Technology	Channel	Detector	Trace	Resolution Bandwidth /kHz	Frequency /MHz	Peak Value /dBm	Limit /dBm	Margin to Limit /dB
NB-IoT eFDD 25 QPSK	low	rms	maxhold	2	1849.99	-28.82	-13	16.82
NB-IoT eFDD 25 QPSK	mid	rms	maxhold	-	-	-	-	-
NB-IoT eFDD 25 QPSK	high	rms	maxhold	2	1915.08	-22.69	-13	9.69

Remark: Please see next sub-clause for the measurement plot.

COMMENT:

No (further) spurious emissions in the range 20dB below the limit were found, therefore no measurement values are reported in the tables.

5.3.4 MEASUREMENT PLOT (SHOWING THE HIGHEST VALUE, "WORST CASE") CAT-M1 eFDD25, CH=high

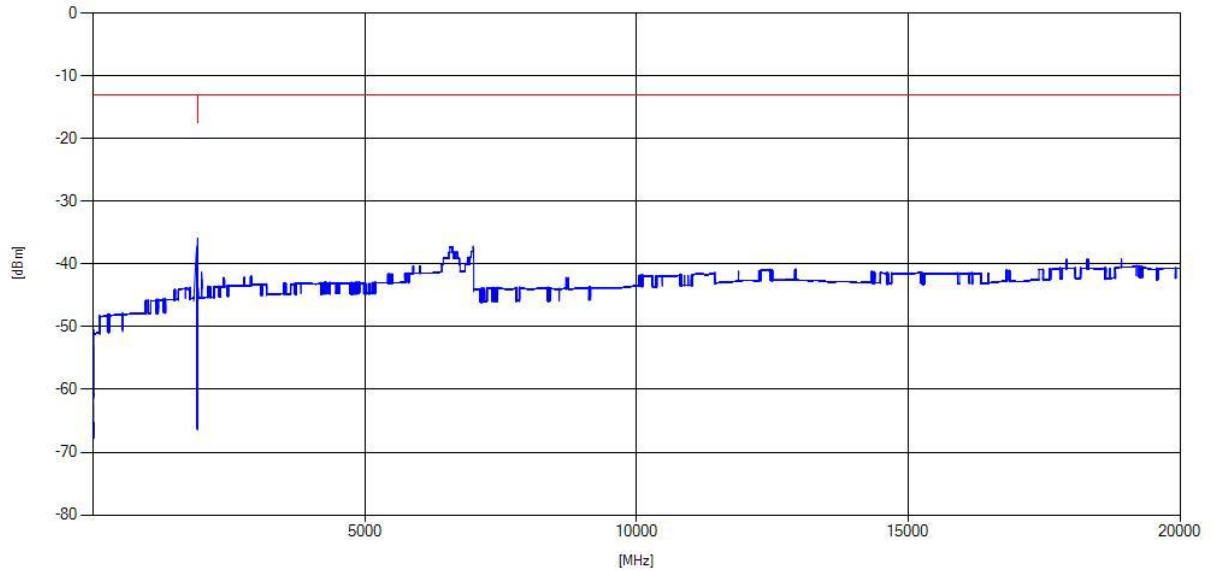

NB-IoT eFDD25, CH=high

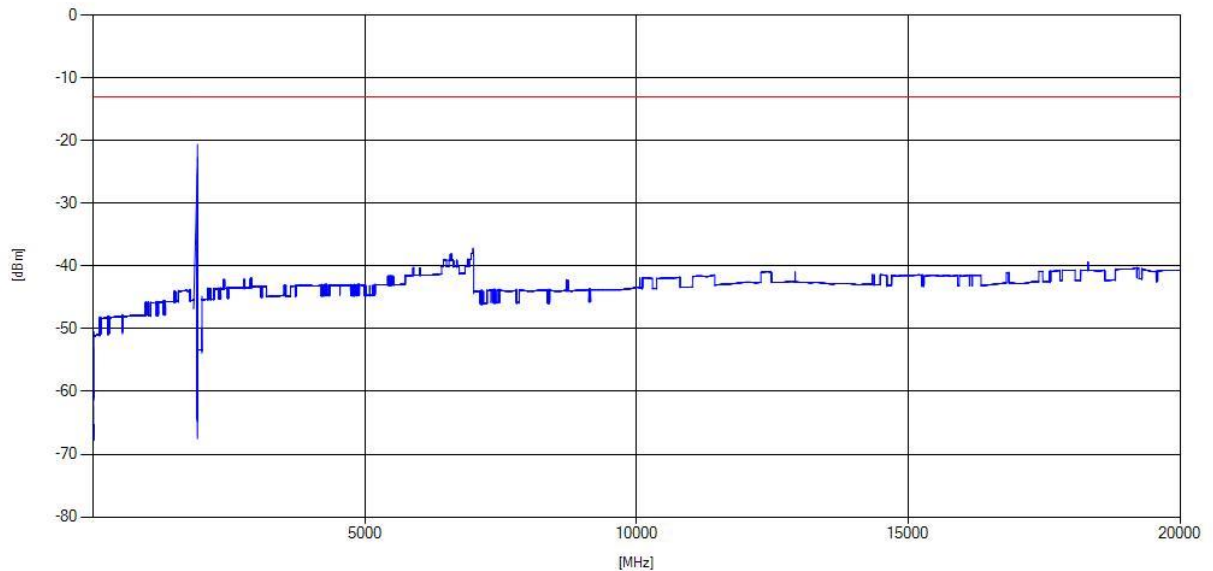

5.3.5 TEST EQUIPMENT USED

- Radio Lab

5.4 FIELD STRENGTH OF SPURIOUS RADIATION

Standard 47 CFR CHAPTER I FCC PART 24 SUBPART B

The test was performed according to:
ANSI C63.26: 2015

5.4.1 TEST DESCRIPTION

This test case is intended to demonstrate compliance to the applicable radiated spurious emission measurements per § 2.1053 and RSS-GEN 6.13. The limit and requirements come from the applicable rule part and ISED RSS-Standard for the operating band of the cellular device.

The EUT was connected to the test setup according to the following diagram:

Frequency Range: 30 MHz – 1 GHz:

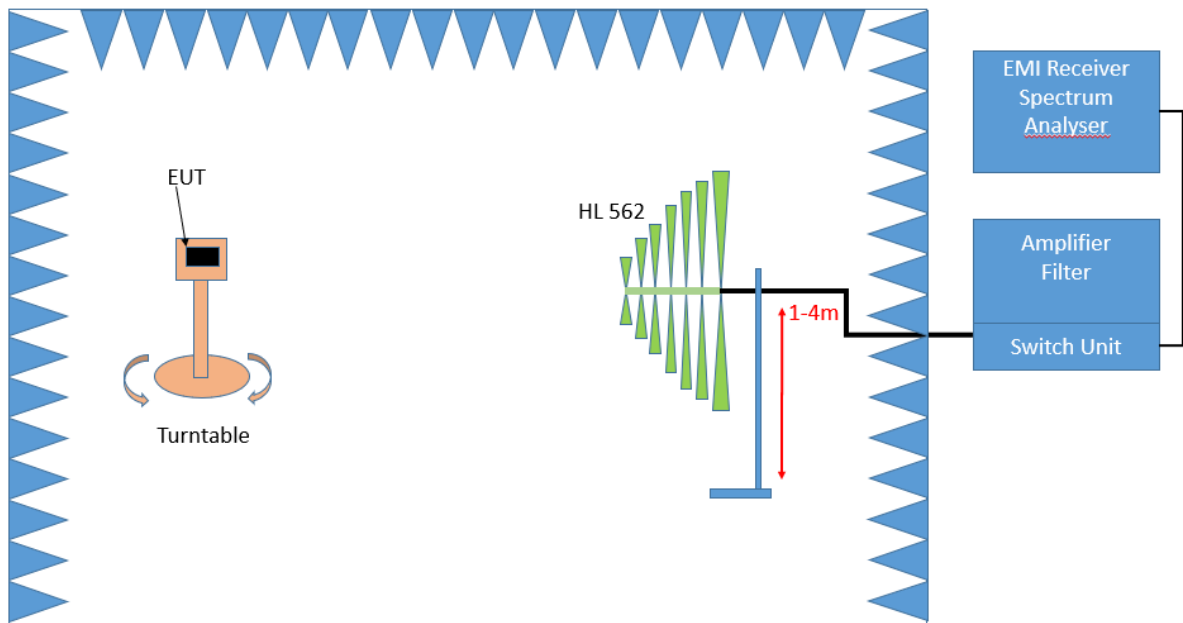

Test Setup; Spurious Emission Radiated (SAC), 30 MHz- 1GHz

Frequency Range: 1 GHz – 26.5 GHz

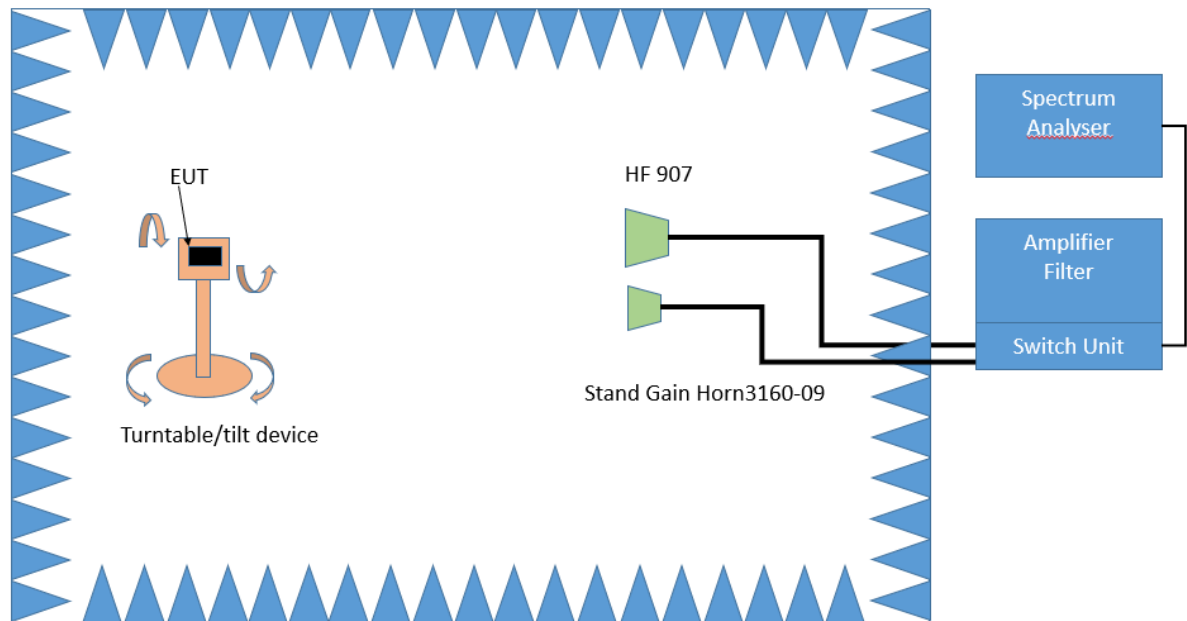

Test Setup; Spurious Emission Radiated (FAC), 1 GHz-26.5 GHz

The test set-up was made in accordance to the general provisions of ANSI C63.26 in a typical installation configuration. The Equipment Under Test (EUT) was set up on a non-conductive table 1.0 x 2.0 m² in the semi-anechoic chamber. The influence of the EUT support table that is used between 30–1000 MHz was evaluated.

The measurement procedure is implemented into the EMI test software EMC32 from R&S. Exploratory tests are performed at 3 orthogonal axes to determine the worst-case orientation of a body-worn or handheld EUT. The final test on all kind of EUTs is also performed at 3 axes. A pre-check is performed while the EUT is powered from a DC power source.

1. Measurement above 30 MHz and up to 1 GHz

Step 1: Preliminary scan

This is a preliminary test to identify the highest amplitudes relative to the limit.

Settings for step 1:

- Antenna distance: 3 m
- Detector: Peak
- RBW: 1000 kHz
- VBW: 3000 kHz
- Sweep time: coupled
- Turntable angle range: -180° to 90°
- Turntable step size: 90°
- Height variation range: 1 – 3 m
- Height variation step size: 2 m
- Polarisation: Horizontal + Vertical

Intention of this step is, to determine the radiated EMI-profile of the EUT. Afterwards the relevant emissions for the final measurement are identified.

Step 2: Adjustment measurement

In this step the accuracy of the turntable azimuth and antenna height will be improved. This is necessary to find out the maximum value of every frequency.

For each frequency, which was determined the turntable azimuth and antenna height will be adjusted. The turntable azimuth will slowly vary by $\pm 45^\circ$ around this value. During this action, the value of emission is continuously measured. The turntable azimuth at the highest emission will be recorded and adjusted. In this position, the antenna height will also slowly vary by ± 100 cm around the antenna height determined. During this action, the value of emission is also continuously measured. The antenna height of the highest emission will also be recorded and adjusted.

- Detector: Peak
- Measured frequencies: in step 1 determined frequencies
- RBW: 1000 kHz
- VBW: 3000 kHz
- Sweep time: coupled
- Turntable angle range: $\pm 45^\circ$ around the determined value
- Height variation range: ± 100 cm around the determined value
- Antenna Polarisation: max. value determined in step 1

Step 3: Final measurement with RMS detector

With the settings determined in step 3, the final measurement will be performed:

EMI receiver settings for step 4:

- Detector: RMQ
- Measured frequencies: in step 1 determined frequencies
- RBW: 1000 kHz
- VBW: 3000 kHz
- Sweep time: 1 s

After the measurement a plot will be generated which contains a diagram with the results of the preliminary scan and a chart with the frequencies and values of the results of the final measurement.

3. Measurement above 1 GHz

The following modifications apply to the measurement procedure for the frequency range above 1 GHz:

Step 1:

The Equipment Under Test (EUT) was set up on a non-conductive support (tilt device) at 1.5 m height in the fully-anechoic chamber.

All steps were performed with one height (1.5 m) of the receiving antenna only.

The EUT is turned during the preliminary measurement across the elevation axis, with a step size of 90° .

The turn table step size (azimuth angle) for the preliminary measurement is 45° .

- Antenna distance: 3 m
- Detector: Peak
- RBW: 1 MHz
- VBW: 3 MHz
- Sweep time: coupled
- Turntable angle range: -180° to 90°
- Turntable step size: 90°
- Polarisation: Horizontal + Vertical

Step 2:

Due to the fact, that in this frequency range the test is performed in a fully anechoic room, the height scan of the receiving antenna in step 2 is omitted. Instead of this, a maximum search with a step size $\pm 45^\circ$ for the elevation axis is performed.

The turn table azimuth will slowly vary by $\pm 22.5^\circ$.

The elevation angle will slowly vary by $\pm 45^\circ$

EMI receiver settings (for all steps):

- Detector: Peak,
- RBW: 1 MHz
- VBW: 3 MHz
- Sweep time: coupled

Step 3:

Spectrum analyser settings for step 3:

- Detector: RMS
- Measured frequencies: in step 1 determined frequencies
- RBW: 1 MHz
- VBW: 3 MHz
- Sweep Time: 1 s

5.4.2 TEST REQUIREMENTS / LIMITS

FCC Part 2.1053; Measurement required: Field strength of spurious radiation:

Measurements shall be made to detect spurious emissions that may be radiated directly from the cabinet, control circuits, power leads, or intermediate circuit elements under normal conditions of installation and operation. Curves or equivalent data shall be supplied showing the magnitude of each harmonic and other spurious emission. For this test, single sideband, independent sideband, and controlled carrier transmitters shall be modulated under the conditions specified in paragraph (c) of §2.1049, as appropriate.

Part 24, Subpart E – Broadband PCS**§ 24.238 – Emission limitations for Broadband PCS equipment**

- a) Out of band emissions. The power of any emission outside of the authorized operating frequency ranges must be attenuated below the transmitting power (P) by a factor of at least $43 + 10 \log(P)$ dB.
- b) Measurement procedure. Compliance with these rules is based on the use of measurement instrumentation employing a resolution bandwidth of 1 MHz or greater. However, in the 1 MHz bands immediately outside and adjacent to the frequency block a resolution bandwidth of at least one percent of the emission bandwidth of the fundamental emission of the transmitter may be employed. A narrower resolution bandwidth is permitted in all cases to improve measurement accuracy provided the measured power is integrated over the full required measurement bandwidth (i.e. 1 MHz or 1 percent of emission bandwidth, as specified). The emission bandwidth is defined as the width of the signal between two points, one below the carrier center frequency and one above the carrier center frequency, outside of which all emissions are attenuated at least 26 dB below the transmitter power.

RSS-133; 6.5 Transmitter Unwanted Emissions

Mobile and base station equipment shall comply with the limits in (1) and (2) below.

1. In the 1.0 MHz bands immediately outside and adjacent to the equipment's operating frequency block, the emission power per any 1% of the emission bandwidth shall be attenuated (in dB) below the transmitter output power P (dBW) by at least $43 + 10 \log_{10} P$ (watts).
2. After the first 1.0 MHz, the emission power in any 1 MHz bandwidth shall be attenuated (in dB) below the transmitter output power P (dBW) by at least $43 + 10 \log_{10} P$ (watts). If the measurement is performed using 1% of the emission bandwidth, power integration over 1.0 MHz is required.

5.4.3 TEST PROTOCOL

Ambient temperature: 22 °C Relative humidity: 36 %

Radio Technology	Channel	Detector	Trace	Resolution Bandwidth /kHz	Frequency /MHz	Peak Value /dBm	Limit /dBm	Margin to Limit /dB
CAT-M1 eFDD 25 QPSK	low	rms	maxhold	1000	1848.52	-25.8	-13	12.78
CAT-M1 eFDD 25 QPSK	mid	peak	maxhold	-	-	-	-	-
CAT-M1 eFDD 25 QPSK	high	rms	maxhold	1000	1917	-32.8	-13	19.76

Radio Technology	Channel	Detector	Trace	Resolution Bandwidth /kHz	Frequency /MHz	Peak Value /dBm	Limit /dBm	Margin to Limit /dB
NB-IoT eFDD 25 QPSK	low	rms	maxhold	2	1849.99	-23.8	-13	10.83
NB-IoT eFDD 25 QPSK	mid	peak	maxhold	-	-	-	-	-
NB-IoT eFDD 25 QPSK	high	peak	maxhold	-	-	-	-	-

Remark: Please see next sub-clause for the measurement plot.

COMMENT:

No (further) spurious emissions in the range 20dB below the limit were found, therefore no measurement values are reported in the tables.

5.4.4 MEASUREMENT PLOT (SHOWING THE HIGHEST VALUE, "WORST CASE")
CAT-M1 eFDD25, CH=low

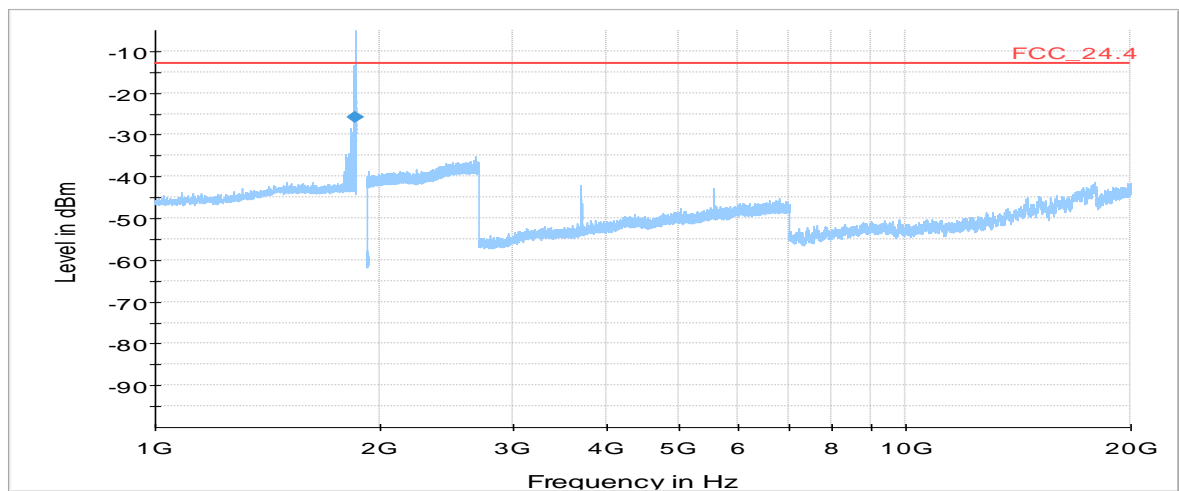
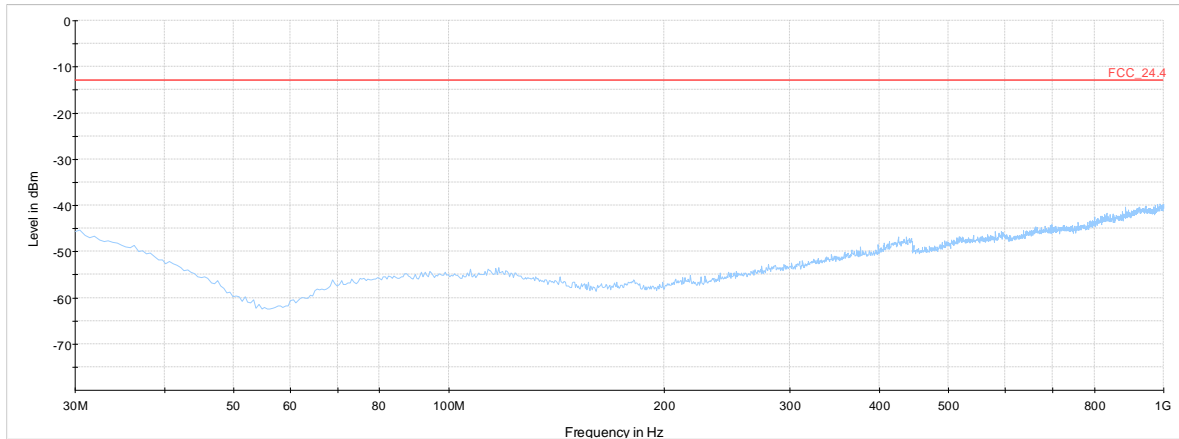

Frequency (MHz)	RMS (dBm)	Limit (dBm)	Margin (dB)	Meas. Time (ms)	Bandwidth (kHz)	Height (cm)	Pol	Azimuth (deg)	Elevation (deg)	Corr. (dB)
1848.528	-25.8	-13.00	12.78	1000.0	1000.000	150.0	V	-137.0	80.0	-65.6

NB-IoT eFDD25, CH=low

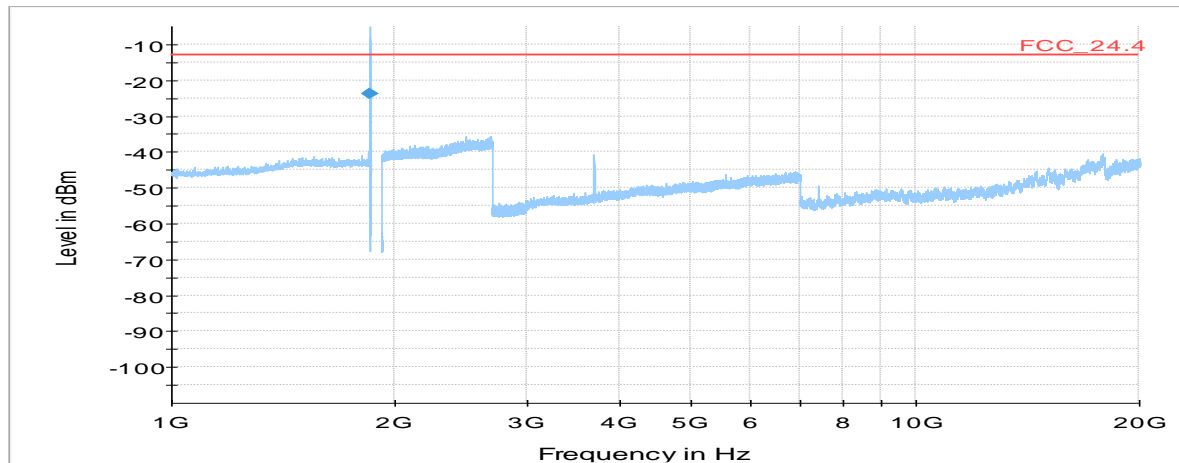
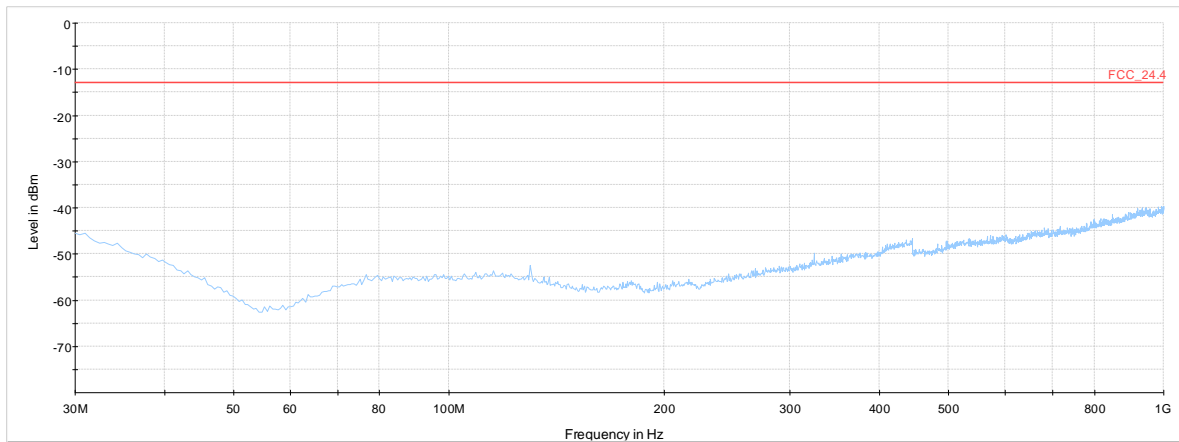

Frequency (MHz)	RMS (dBm)	Limit (dBm)	Margin (dB)	Meas. Time (ms)	Bandwidth (kHz)	Height (cm)	Pol	Azimuth (deg)	Elevation (deg)	Corr. (dB)
1849.996	-23.8	-13.00	10.83	1000.0	2.000	150.0	V	-156.0	88.0	-65.6

5.4.5 TEST EQUIPMENT USED

- Radiated Emissions

5.5 EMISSION AND OCCUPIED BANDWIDTH

Standard 47 CFR CHAPTER I FCC PART 24 SUBPART B

The test was performed according to:
ANSI C63.26: 2015

5.5.1 TEST DESCRIPTION

This test case is intended to demonstrate compliance to the applicable conducted spurious emission test case per FCC §2.1049 and RSS-GEN 6.7. The limit and the requirements come from the applicable rule part and ISED RSS-Standard for the operating band of the cellular device.

The EUT was connected to the test setups according to the following diagram:

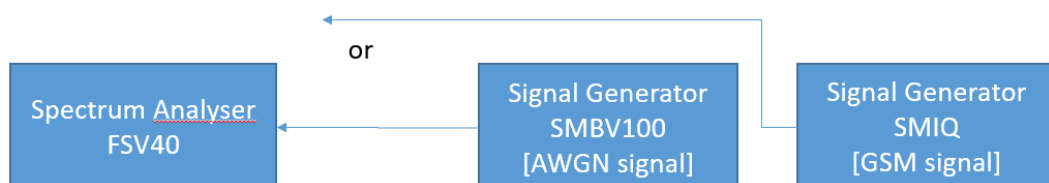

FCC Part 22/24/27/90; Industrial Signal Booster
Test Setup step 1; Measuring characteristics of test signals

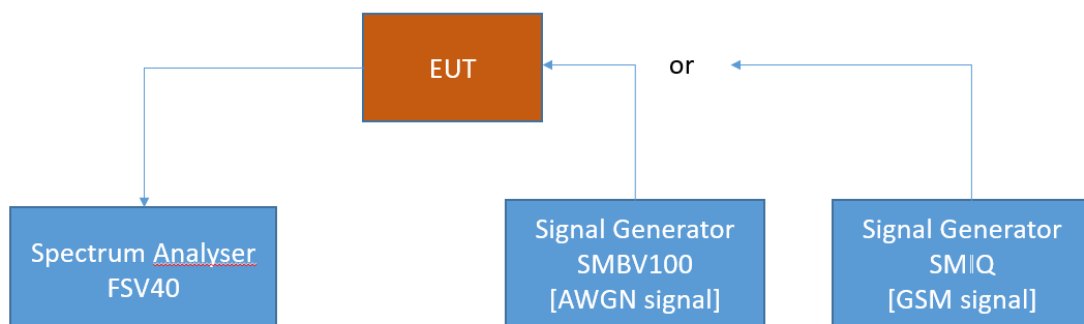

FCC Part 22/24/27/90; Industrial Signal Booster
Test Setup step 2; Occupied Bandwidth/Input-versus-output spectrum

The attenuation of the measuring and stimulus path are known for each measured frequency and are considered.

The Spectrum Analyzer settings can be directly found in the measurement diagrams.

5.5.2 TEST REQUIREMENTS / LIMITS

FCC Part 2.1049; Occupied Bandwidth:

The occupied bandwidth, that is the frequency bandwidth such that, below its lower and above its upper frequency limits, the mean powers radiated are each equal to 0.5 percent of the total mean power radiated by a given emission shall be measured under the following conditions as applicable:

(h) Transmitters employing digital modulation techniques—when modulated by an input signal such that its amplitude and symbol rate represent the maximum rated conditions under which the equipment will be operated. The signal shall be applied through any filter networks, pseudo-random generators or other devices required in normal service. Additionally, the occupied bandwidth shall be shown for operation with any devices used for modifying the spectrum when such devices are optional at the discretion of the user.

(i) Transmitters designed for other types of modulation—when modulated by an appropriate signal of sufficient amplitude to be representative of the type of service in which used. A description of the input signal should be supplied.

RSS-GEN; 6.7 Occupied Bandwidth (or 99% emission bandwidth) and x dB bandwidth

The occupied bandwidth or the “99% emission bandwidth” is defined as the frequency range between two points, one above and the other below the carrier frequency, within which 99% of the total transmitted power of the fundamental transmitted emission is contained. The occupied bandwidth shall be reported for all equipment in addition to the specified bandwidth required in the applicable RSSs.

In some cases, the “x dB bandwidth” is required, which is defined as the frequency range between two points, one at the lowest frequency below and one at the highest frequency above the carrier frequency, at which the maximum power level of the transmitted emission is attenuated x dB below the maximum in-band power level of the modulated signal, where the two points are on the outskirts of the in-band emission.

The following conditions shall be observed for measuring the occupied bandwidth and x dB bandwidth:

The transmitter shall be operated at its maximum carrier power measured under normal test conditions.

The span of the spectrum analyzer shall be set large enough to capture all products of the modulation process, including the emission skirts, around the carrier frequency, but small enough to avoid having other emissions (e.g. on adjacent channels) within the span. The detector of the spectrum analyzer shall be set to “Sample”. However, a peak, or peak hold, may be used in place of the sampling detector since this usually produces a wider bandwidth than the actual bandwidth (worst-case measurement). Use of a peak hold (or “Max Hold”) may be necessary to determine the occupied / x dB bandwidth if the device is not transmitting continuously.

The resolution bandwidth (RBW) shall be in the range of 1% to 5% of the actual occupied / x dB bandwidth and the video bandwidth (VBW) shall not be smaller than three times the RBW value. Video averaging is not permitted.

Note: It may be necessary to repeat the measurement a few times until the RBW and VBW are in compliance with the above requirement.

For the 99% emission bandwidth, the trace data points are recovered and directly summed in linear power level terms. The recovered amplitude data points, beginning at the lowest frequency, are placed in a running sum until 0.5% of the total is reached, and that frequency recorded. The process is repeated for the highest frequency data points (starting at the highest frequency, at the right side of the span, and going down in frequency). This frequency is then recorded. The difference between the two recorded frequencies is the occupied bandwidth (or the 99% emission bandwidth).

5.5.3 TEST PROTOCOL

Ambient temperature: 24 °C
Relative humidity: 34 %

Radio Technology	Channel	Ressource Blocks / Subcarrier	Bandwidth [MHz]	99 % BW [kHz]
CAT-M1 eFDD 25 QPSK	low	6	1.4	1106.21
CAT-M1 eFDD 25 QPSK	mid	6	1.4	1106.21
CAT-M1 eFDD 25 QPSK	high	6	1.4	1106.21
CAT-M1 eFDD 25 16QAM	low	5	1.4	937.88
CAT-M1 eFDD 25 16QAM	mid	5	1.4	937.88
CAT-M1 eFDD 25 16QAM	high	5	1.4	949.9
NB-IoT eFDD 25 QPSK	low	12	0.2	188.38
NB-IoT eFDD 25 QPSK	mid	12	0.2	188.38
NB-IoT eFDD 25 QPSK	high	12	0.2	188.38
NB-IoT eFDD 25 BPSK	low	1	0.2	66.13
NB-IoT eFDD 25 BPSK	mid	1	0.2	64.13
NB-IoT eFDD 25 BPSK	high	1	0.2	66.13

Remark: Please see next sub-clause for the measurement plot.

5.5.4 MEASUREMENT PLOT (SHOWING THE HIGHEST VALUE, "WORST CASE")

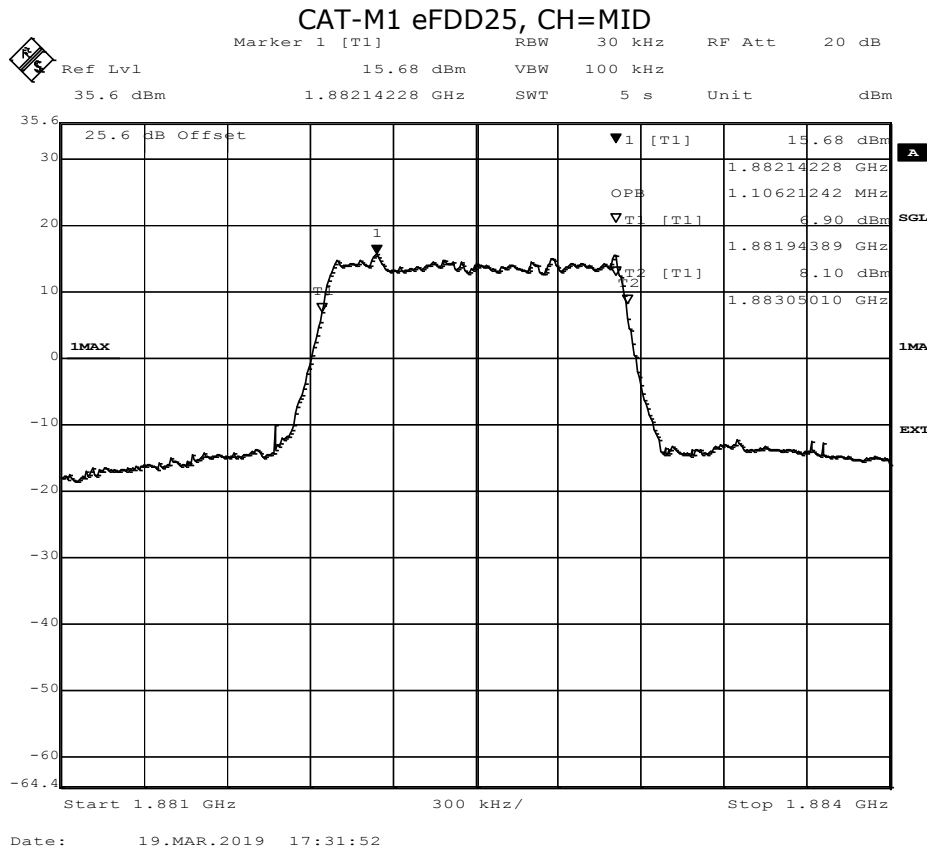

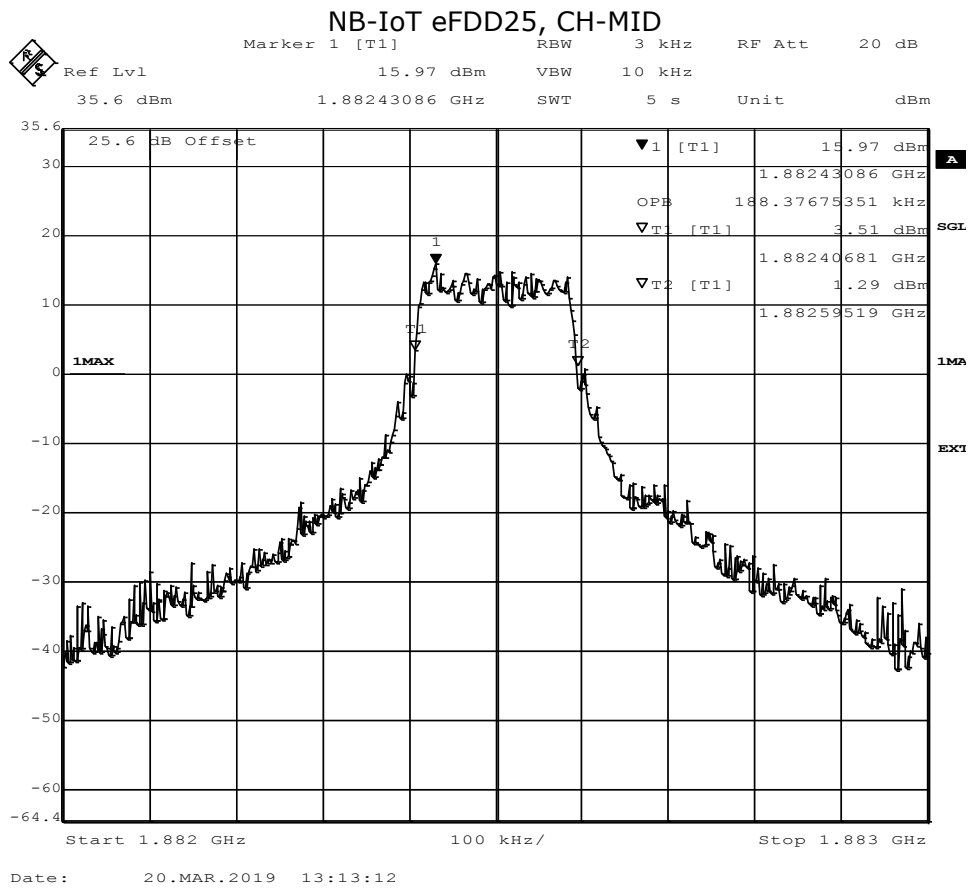

5.5.5 TEST EQUIPMENT USED

- Radio Lab

5.6 BAND EDGE COMPLIANCE

Standard 47 CFR CHAPTER I FCC PART 24 SUBPART B

The test was performed according to:
ANSI C63.26: 2015

5.6.1 TEST DESCRIPTION

This test case is intended to demonstrate compliance to the applicable conducted spurious emission test case per § 2.1051 and RSS-GEN 6.13. The limit comes from the applicable rule part and ISSED RSS-Standard for the operating band of the cellular device.

The EUT was connected to the test setup according to the following diagram:

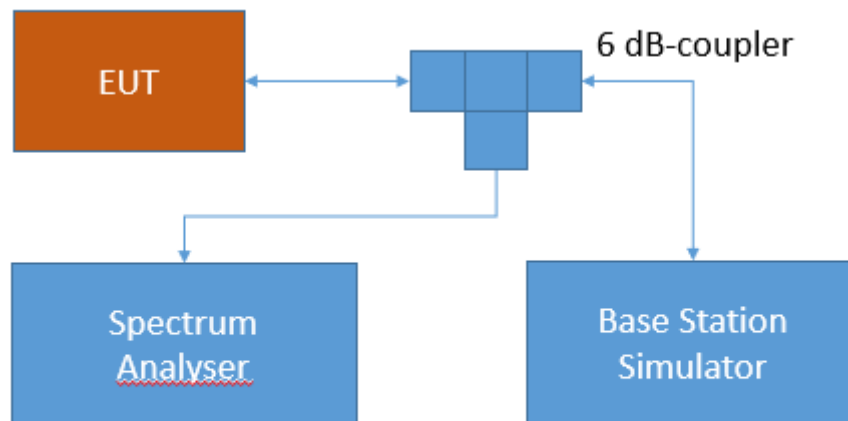

Test Setup FCC Part 22/24/27/90 Cellular;
Band edge compliance

The attenuation of the measuring and stimulus path are known for each measured frequency and are considered.

The Spectrum Analyzer settings can be directly found in the measurement diagrams.

5.6.2 TEST REQUIREMENTS / LIMITS

FCC Part 2.1051; Measurement required: Spurious emissions at antenna terminal:

The radio frequency voltage or powers generated within the equipment and appearing on a spurious frequency shall be checked at the equipment output terminals when properly loaded with a suitable artificial antenna. Curves or equivalent data shall show the magnitude of each harmonic and other spurious emission that can be detected when the equipment is operated

under the conditions specified in §2.1049 as appropriate. The magnitude of spurious emissions which are attenuated more than 20 dB below the permissible value need not be specified.

Part 24, Subpart E – Broadband PCS

§24.238 – Emission limitations for Broadband PCS equipment

- a) Out of band emissions. The power of any emission outside of the authorized operating frequency ranges must be attenuated below the transmitting power (P) by a factor of at least $43 + 10 \log(P)$ dB.
- b) Measurement procedure. Compliance with these rules is based on the use of measurement instrumentation employing a resolution bandwidth of 1 MHz or greater. However, in the 1 MHz bands immediately outside and adjacent to the frequency block a resolution bandwidth of at least one percent of the emission bandwidth of the fundamental emission of the transmitter may be employed. A narrower resolution bandwidth is permitted in all cases to improve measurement accuracy provided the measured power is integrated over the full required measurement bandwidth (i.e. 1 MHz or 1 percent of emission bandwidth, as specified). The emission bandwidth is defined as the width of the signal between two points, one below the carrier center frequency and one above the carrier center frequency, outside of which all emissions are attenuated at least 26 dB below the transmitter power.

RSS-133; 6.5 Transmitter Unwanted Emissions

Mobile and base station equipment shall comply with the limits in (1) and (2) below.

1. In the 1.0 MHz bands immediately outside and adjacent to the equipment's operating frequency block, the emission power per any 1% of the emission bandwidth shall be attenuated (in dB) below the transmitter output power P (dBW) by at least $43 + 10 \log_{10}p$ (watts).
2. After the first 1.0 MHz, the emission power in any 1 MHz bandwidth shall be attenuated (in dB) below the transmitter output power P (dBW) by at least $43 + 10 \log_{10}p$ (watts). If the measurement is performed using 1% of the emission bandwidth, power integration over 1.0 MHz is required.

5.6.3 TEST PROTOCOL

Ambient temperature: 22 °C
Relative humidity: 32 %

Radio Technology	Channel	Resource Blocks / Subcarrier	Bandwidth [MHz]	Peak [dBm]	Average [dBm]	RMS [dBm]	Limit /dBm	Margin to Limit /dB
CAT-M1 eFDD 25 QPSK	low	6	1.4	-16.13	-28.27	-27.2	-13	14.2
CAT-M1 eFDD 25 QPSK	high	6	1.4	-16.45	-27	-25.71	-13	12.71
CAT-M1 eFDD 25 16QAM	low	5	1.4	-16.99	-27.2	-26.24	-13	13.24
CAT-M1 eFDD 25 16QAM	high	5	1.4	-18.59	-27.61	-25.89	-13	12.89
NB-IoT eFDD 25 QPSK	low	12	0.2	-8.89	-30.42	-20.18	-13	7.18
NB-IoT eFDD 25 QPSK	high	12	0.2	-3.02	-28.24	-16.51	-13	3.51
NB-IoT eFDD 25 BPSK	low	1	0.2	-17.76	-26.7	-27.54	-13	14.54
NB-IoT eFDD 25 BPSK	high	1	0.2	-19.13	-27.77	-26.3	-13	13.3

Remark: Please see next sub-clause for the measurement plot.

5.6.4 MEASUREMENT PLOT (SHOWING THE HIGHEST VALUE, "WORST CASE")

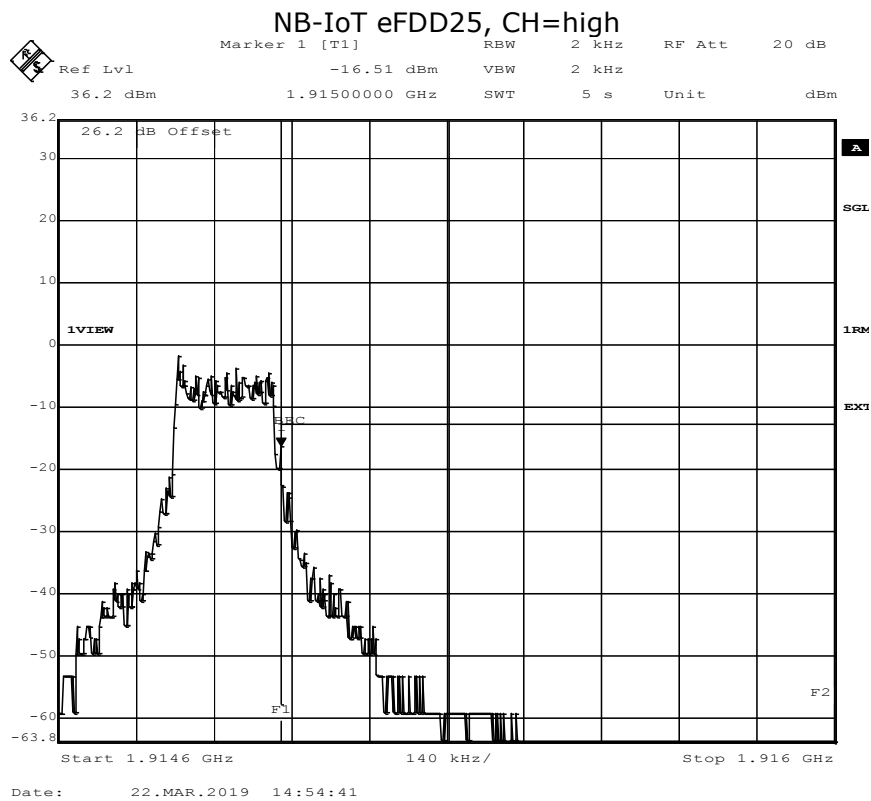
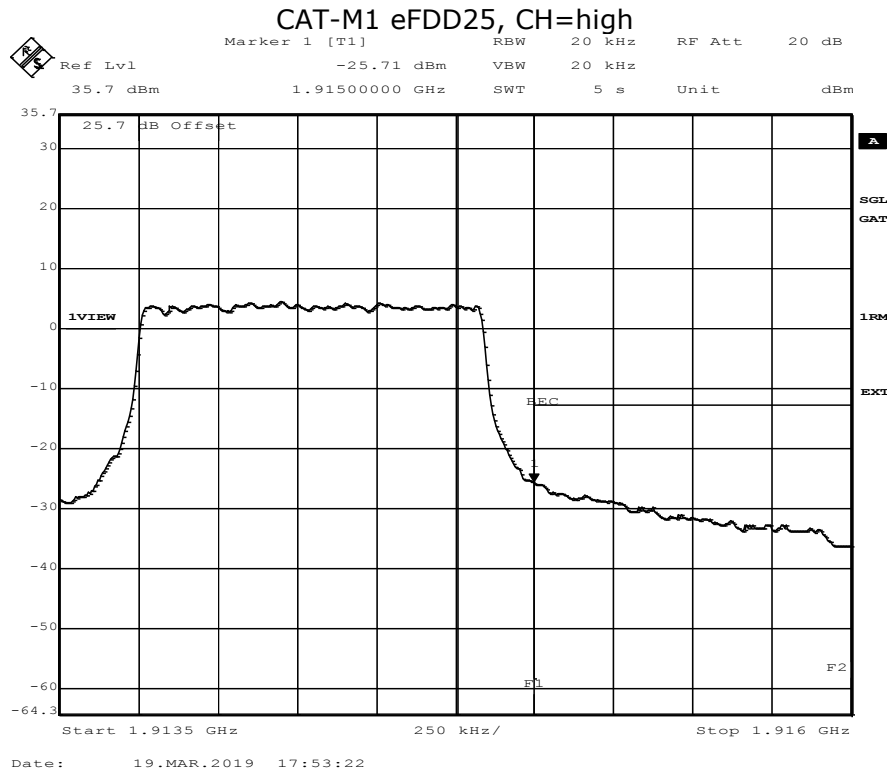

5.6.5 TEST EQUIPMENT USED

- Radio Lab

5.7 PEAK TO AVERAGE RATIO

Standard 47 CFR CHAPTER I FCC PART 24 SUBPART B

The test was performed according to:

ANSI C63.26: 2015

5.7.1 TEST DESCRIPTION

This test case is intended to demonstrate compliance of the EUT to the peak-to-average limits and requirements of the applicable rule part and ISSED RSS-Standard for the operating band of the cellular device.

The EUT was connected to the test setup according to the following diagram:

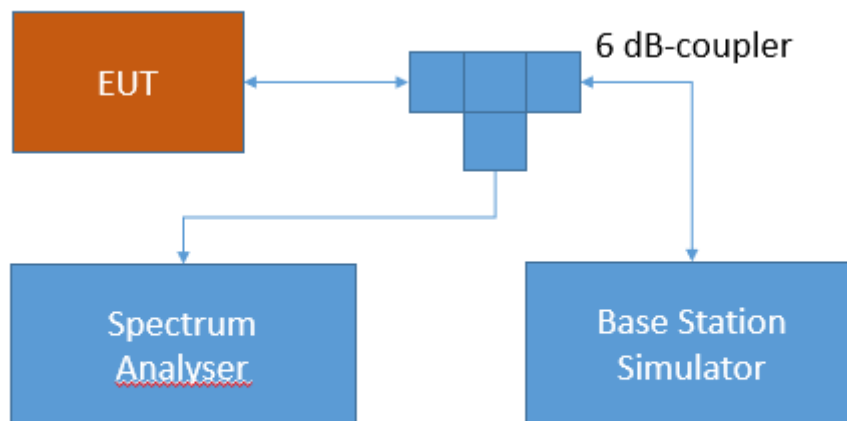

Test Setup FCC Part 22/24/27/90 Cellular;
Peak-average ratio

The attenuation of the measuring and stimulus path are known for each measured frequency and are considered.

The Spectrum Analyzer settings can be directly found in the measurement diagrams. The internal CCDF (complementary cumulative distribution function) of the spectrum analyser is used for this measurement

5.7.2 TEST REQUIREMENTS / LIMITS

FCC Part 24, § 24.232

(d) Power measurements for transmissions by stations authorized under this section may be made either in accordance with a Commission-approved average power technique or in compliance with paragraph (e) of this section. In both instances, equipment employed must be authorized in accordance with the provisions of §24.51. In measuring transmissions in this band using an average power technique, the peak-to-average ratio (PAR) of the transmission may not exceed 13 dB.

RSS-133; 6.4 Transmitter Output Power and Equivalent Isotropically Radiated Power

In addition, the peak-to-average power ratio (PAPR) of the transmitter shall not exceed 13 dB for more than 0.1% of the time using a signal corresponding to the highest PAPR during periods of continuous transmission.

5.7.3 TEST PROTOCOL

Ambient temperature: 22 °C
Relative humidity: 32 %

Radio Technology	Channel	Ressource Blocks / Subcarrier	Bandwidth [MHz]	Peak to Average Ratio	Limit (IC) [dB]
CAT-M1 eFDD 25 QPSK	low	6	1.4	10.78	13
CAT-M1 eFDD 25 QPSK	mid	6	1.4	10.78	13
CAT-M1 eFDD 25 QPSK	high	6	1.4	10.58	13
CAT-M1 eFDD 25 16QAM	low	5	1.4	11.57	13
CAT-M1 eFDD 25 16QAM	mid	5	1.4	10.78	13
CAT-M1 eFDD 25 16QAM	high	5	1.4	11.86	13
NB-IoT eFDD 25 QPSK	low	12	0.2	6.46	13
NB-IoT eFDD 25 QPSK	mid	12	0.2	6.67	13
NB-IoT eFDD 25 QPSK	high	12	0.2	6.41	13
NB-IoT eFDD 25 BPSK	low	1	0.2	1.8	13
NB-IoT eFDD 25 BPSK	mid	1	0.2	1.74	13
NB-IoT eFDD 25 BPSK	high	1	0.2	1.8	13

Remark: Please see next sub-clause for the measurement plot.

5.7.4 MEASUREMENT PLOT (SHOWING THE HIGHEST VALUE, "WORST CASE") CAT-M1 eFDD25, CH=high

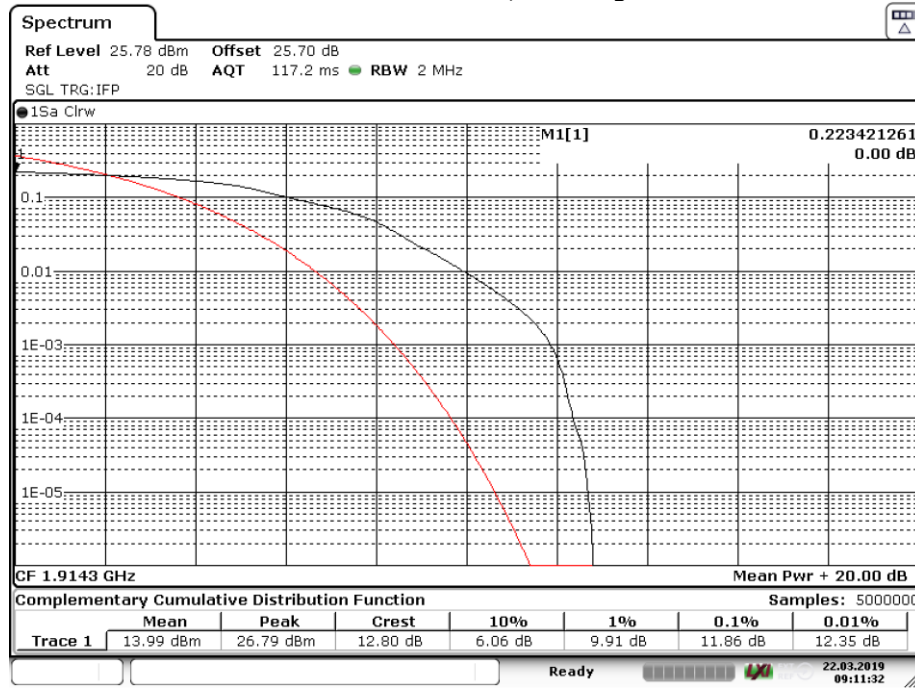

Date: 22.MAR.2019 09:11:33

NB-IoT eFDD25, CH=MID

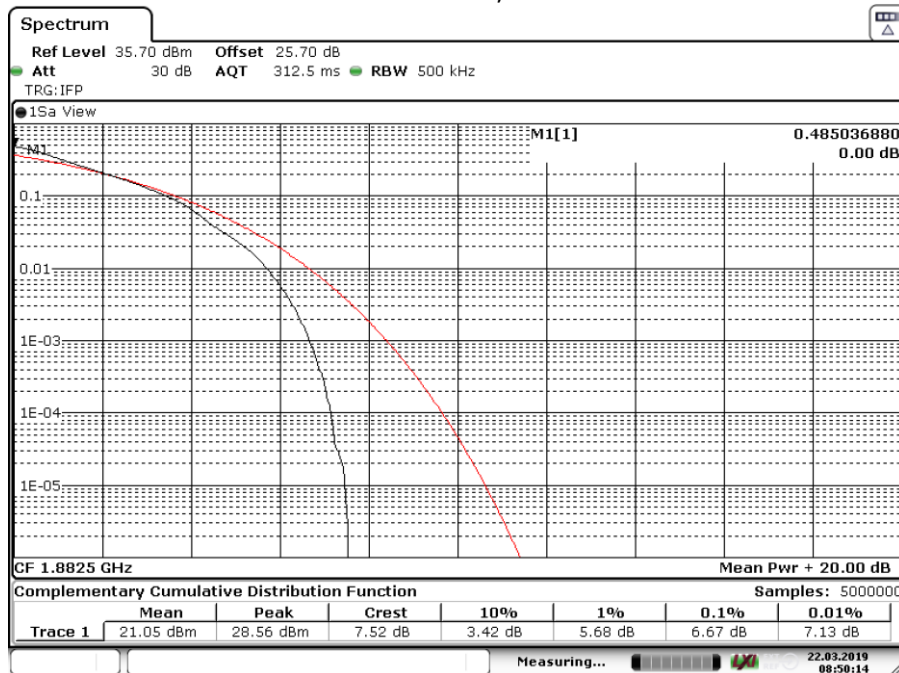

Date: 22.MAR.2019 08:50:14

5.7.5 TEST EQUIPMENT USED

- Radio Lab

Test Equipment

- 1 Radiated Emissions
Lab to perform radiated emission tests

Ref.No.	Device Name	Description	Manufacturer	Serial Number	Last Calibration	Calibration Due
1.1	NRV-Z1	Sensor Head A	Rohde & Schwarz GmbH & Co. KG	827753/005	2018-07	2019-07
1.2	MFS	Rubidium Frequency Normal MFS	Datum GmbH	002	2018-10	2020-10
1.3	Opus10 TPR (8253.00)	ThermoAirpressure Datalogger 13 (Environ)	Lufft Mess- und Regeltechnik GmbH	13936	2017-04	2019-04
1.4	ESW44	EMI Test Receiver	Rohde & Schwarz GmbH & Co. KG	101603	2018-05	2019-05
1.5	Anechoic Chamber	10.58 x 6.38 x 6.00 m ³	Frankonia	none	2018-06	2020-06
1.6	FS-Z60	Harmonic Mixer 40 - 60 GHz	Rohde & Schwarz Messgerätebau GmbH	100178	2016-12	2019-12
1.7	FS-Z220	Harmonic Mixer 140 - 220 GHz	Rohde & Schwarz Messgerätebau GmbH	101005	2017-03	2020-03
1.8	SGH-05	Standard Gain / Pyramidal Horn Antenna (140 - 220 GHz)	RPG-Radiometer Physics GmbH	075		
1.9	HL 562	Ultralog new biconicals	Rohde & Schwarz	830547/003	2018-07	2021-07
1.10	5HC2700/12750-1.5-KK	High Pass Filter	Trilithic	9942012		
1.11	ASP 1.2/1.8-10 kg	Antenna Mast	Maturo GmbH	-		
1.12	Fully Anechoic Room	8.80m x 4.60m x 4.05m (l x w x h)	Albatross Projects	P26971-647-001-PRB	2018-06	2020-06
1.13	Fluke 177	Digital Multimeter 03 (Multimeter)	Fluke Europe B.V.	86670383	2018-04	2020-04
1.14	NRVD	Power Meter	Rohde & Schwarz GmbH & Co. KG	828110/016	2018-07	2019-07
1.15	HF 906	Double-ridged horn	Rohde & Schwarz	357357/002	2018-09	2021-09
1.16	JS4-18002600-32-5P	Broadband Amplifier 18 GHz - 26 GHz	Miteq	849785		
1.17	FSW 43	Spectrum Analyzer	Rohde & Schwarz	103779	2019-02	2021-02
1.18	3160-09	Standard Gain / Pyramidal Horn Antenna 26.5 GHz	EMCO Elektronik GmbH	00083069		
1.19	SGH-19	Standard Gain / Pyramidal Horn Antenna (40 - 60 GHz)	RPG-Radiometer Physics GmbH	093		

Ref.No.	Device Name	Description	Manufacturer	Serial Number	Last Calibration	Calibration Due
1.20	WHKX 7.0/18G-8SS	High Pass Filter	Wainwright	09		
1.21	4HC1600/12750-1.5-KK	High Pass Filter	Trilithic	9942011		
1.22	Chroma 6404	AC Power Source	Chroma ATE INC.	64040001304		
1.23	JS4-00102600-42-5A	Broadband Amplifier 30 MHz - 26 GHz	Miteq	619368		
1.24	TT 1.5 WI	Turn Table	Maturo GmbH	-		
1.25	HL 562 Ultralog	Log.-per. Antenna	Rohde & Schwarz	100609	2016-04	2019-04
1.26	HF 906	Double-ridged horn	Rohde & Schwarz	357357/001	2018-03	2021-03
1.27	FS-Z325	Harmonic Mixer 220 - 325 GHz	Rohde & Schwarz Messgerätebau GmbH	101006	2017-03	2020-03
1.28	3160-10	Standard Gain / Pyramidal Horn Antenna 40 GHz	EMCO Elektronik GmbH	00086675		
1.29	SGH-08	Standard Gain / Pyramidal Horn Antenna (90 - 140 GHz)	RPG-Radiometer Physics GmbH	064		
1.30	SGH-12	Standard Gain / Pyramidal HornAntenna (60 - 90 GHz)	RPG-Radiometer Physics GmbH	326		
1.31	5HC3500/18000-1.2-KK	High Pass Filter	Trilithic	200035008		
1.32	FS-Z140	Harmonic Mixer 90 -140 GHz	Rohde & Schwarz Messgerätebau GmbH	101007	2017-02	2020-02
1.33	HFH2-Z2	Loop Antenna	Rohde & Schwarz	829324/006	2018-01	2021-01
1.34	Opus10 THI (8152.00)	ThermoHygro Datalogger 12 (Environ)	Luft Mess- und Regeltechnik GmbH	12482	2017-03	2019-03
1.35	ESR 7	EMI Receiver / Spectrum Analyzer	Rohde & Schwarz	101424	2019-01	2020-01
1.36	JS4-00101800-35-5P	Broadband Amplifier 30 MHz - 18 GHz	Miteq	896037		
1.37	AS 620 P	Antenna mast	HD GmbH	620/37		
1.38	Tilt device Maturo (Rohacell)	Antrieb TD1.5-10kg	Maturo GmbH	TD1.5-10kg/024/3790709		
1.39	SGH-03	Standard Gain / Pyramidal Horn Antenna (220 - 325 GHz)	RPG-Radiometer Physics GmbH	060		
1.40	FS-Z90	Harmonic Mixer 60 - 90 GHz	Rohde & Schwarz Messgerätebau GmbH	101686	2017-03	2020-03

Ref.No.	Device Name	Description	Manufacturer	Serial Number	Last Calibration	Calibration Due
1.41	ESIB 26	Spectrum Analyzer	Rohde & Schwarz	830482/004	2018-01	2020-01
1.42	PAS 2.5 - 10 kg	Antenna Mast	Maturo GmbH	-		
1.43	AFS42-00101800-25-S-42	Broadband Amplifier 25 MHz - 18 GHz	Miteq	2035324		
1.44	AM 4.0	Antenna mast	Maturo GmbH	AM4.0/180/11920513		
1.45	HF 907	Double-ridged horn	Rohde & Schwarz	102444	2018-07	2021-07

2 Radio Lab
Conducted Radio Test Lab

Ref.No.	Device Name	Description	Manufacturer	Serial Number	Last Calibration	Calibration Due
2.1	SMB100A	Signal Generator 9 kHz - 6 GHz	Rohde & Schwarz	107695	2017-07	2020-07
2.2	MFS	Rubidium Frequency Standard	Datum-Beverly	5489/001	2018-07	2019-07
2.3	FSV30	Signal Analyzer 10 Hz - 30 GHz	Rohde & Schwarz	103005	2018-04	2020-04
2.4	Fluke 177	Digital Multimeter 03 (Multimeter)	Fluke Europe B.V.	86670383	2018-04	2020-04
2.5	SMP03	Signal Generator 2 GHz - 27 GHz	Rohde & Schwarz	833680/003	2017-09	2020-09
2.6	FSIQ26	Signal Analyser	Rohde & Schwarz	840061/005	2017-05	2019-05
2.7	Chroma 6404	AC Power Source	Chroma ATE INC.	64040001304		
2.8	VT 4002	Temperature Chamber	Vötsch	58566002150010	2018-04	2020-04
2.9	WA1515	Broadband Power Divider SMA	Weinschel Associates	A855		
2.10	A8455-4	4 Way Power Divider (SMA)		-		
2.11	Opus10 THI (8152.00)	ThermoHygro Datalogger 03 (Environ)	Lufft Mess- und Regeltechnik GmbH	7482	2017-03	2019-03
2.12	SMBV100A	Vector Signal Generator 9 kHz - 6 GHz	Rohde & Schwarz	259291	2016-10	2019-10

The calibration interval is the time interval between "Last Calibration" and "Calibration Due"

6 ANTENNA FACTORS, CABLE LOSS AND SAMPLE CALCULATIONS

This chapter contains the antenna factors with their corresponding path loss of the used measurement path for all antennas as well as the insertion loss of the LISN.

6.1 LISN R&S ESH3-Z5 (150 KHZ – 30 MHZ)

Frequency MHz	Corr. dB	LISN insertion loss ESH3- Z5 dB	cable loss (incl. 10 dB atten- uator) dB
0.15	10.1	0.1	10.0
5	10.3	0.1	10.2
7	10.5	0.2	10.3
10	10.5	0.2	10.3
12	10.7	0.3	10.4
14	10.7	0.3	10.4
16	10.8	0.4	10.4
18	10.9	0.4	10.5
20	10.9	0.4	10.5
22	11.1	0.5	10.6
24	11.1	0.5	10.6
26	11.2	0.5	10.7
28	11.2	0.5	10.7
30	11.3	0.5	10.8

Sample calculation

$$U_{\text{LISN}} (\text{dB } \mu\text{V}) = U (\text{dB } \mu\text{V}) + \text{Corr. (dB)}$$

U = Receiver reading

LISN Insertion loss = Voltage Division Factor of LISN

Corr. = sum of single correction factors of used LISN, cables, switch units (if used)

Linear interpolation will be used for frequencies in between the values in the table.

6.2 ANTENNA R&S HFH2-Z2 (9 KHZ – 30 MHZ)

Frequency MHz	AF HFH-Z2) dB (1/m)	Corr. dB	cable loss 1 (inside chamber) dB	cable loss 2 (outside chamber) dB	cable loss 3 (switch unit) dB	cable loss 4 (to receiver) dB	distance corr. (-40 dB/ decade) dB	d _{Limit} (meas. distance (limit) m	d _{used} (meas. distance (used) m
0.009	20.50	-79.6	0.1	0.1	0.1	0.1	-80	300	3
0.01	20.45	-79.6	0.1	0.1	0.1	0.1	-80	300	3
0.015	20.37	-79.6	0.1	0.1	0.1	0.1	-80	300	3
0.02	20.36	-79.6	0.1	0.1	0.1	0.1	-80	300	3
0.025	20.38	-79.6	0.1	0.1	0.1	0.1	-80	300	3
0.03	20.32	-79.6	0.1	0.1	0.1	0.1	-80	300	3
0.05	20.35	-79.6	0.1	0.1	0.1	0.1	-80	300	3
0.08	20.30	-79.6	0.1	0.1	0.1	0.1	-80	300	3
0.1	20.20	-79.6	0.1	0.1	0.1	0.1	-80	300	3
0.2	20.17	-79.6	0.1	0.1	0.1	0.1	-80	300	3
0.3	20.14	-79.6	0.1	0.1	0.1	0.1	-80	300	3
0.49	20.12	-79.6	0.1	0.1	0.1	0.1	-80	300	3
0.490001	20.12	-39.6	0.1	0.1	0.1	0.1	-40	30	3
0.5	20.11	-39.6	0.1	0.1	0.1	0.1	-40	30	3
0.8	20.10	-39.6	0.1	0.1	0.1	0.1	-40	30	3
1	20.09	-39.6	0.1	0.1	0.1	0.1	-40	30	3
2	20.08	-39.6	0.1	0.1	0.1	0.1	-40	30	3
3	20.06	-39.6	0.1	0.1	0.1	0.1	-40	30	3
4	20.05	-39.5	0.2	0.1	0.1	0.1	-40	30	3
5	20.05	-39.5	0.2	0.1	0.1	0.1	-40	30	3
6	20.02	-39.5	0.2	0.1	0.1	0.1	-40	30	3
8	19.95	-39.5	0.2	0.1	0.1	0.1	-40	30	3
10	19.83	-39.4	0.2	0.1	0.2	0.1	-40	30	3
12	19.71	-39.4	0.2	0.1	0.2	0.1	-40	30	3
14	19.54	-39.4	0.2	0.1	0.2	0.1	-40	30	3
16	19.53	-39.3	0.3	0.1	0.2	0.1	-40	30	3
18	19.50	-39.3	0.3	0.1	0.2	0.1	-40	30	3
20	19.57	-39.3	0.3	0.1	0.2	0.1	-40	30	3
22	19.61	-39.3	0.3	0.1	0.2	0.1	-40	30	3
24	19.61	-39.3	0.3	0.1	0.2	0.1	-40	30	3
26	19.54	-39.3	0.3	0.1	0.2	0.1	-40	30	3
28	19.46	-39.2	0.3	0.1	0.3	0.1	-40	30	3
30	19.73	-39.1	0.4	0.1	0.3	0.1	-40	30	3

Sample calculation

$$E \text{ (dB } \mu\text{V/m)} = U \text{ (dB } \mu\text{V)} + AF \text{ (dB 1/m)} + Corr. \text{ (dB)}$$

U = Receiver reading

AF = Antenna factor

Corr. = sum of single correction factors of used cables, switch unit, distance correction, amplifier (if applicable)

distance correction = $-40 * \text{LOG} (d_{\text{Limit}} / d_{\text{used}})$

Linear interpolation will be used for frequencies in between the values in the table.

Table shows an extract of values

6.3 ANTENNA R&S HL562 (30 MHZ – 1 GHZ)

($d_{Limit} = 3\text{ m}$)

Frequency	AF R&S HL562	Corr.
MHz	dB (1/m)	dB
30	18.6	0.6
50	6.0	0.9
100	9.7	1.2
150	7.9	1.6
200	7.6	1.9
250	9.5	2.1
300	11.0	2.3
350	12.4	2.6
400	13.6	2.9
450	14.7	3.1
500	15.6	3.2
550	16.3	3.5
600	17.2	3.5
650	18.1	3.6
700	18.5	3.6
750	19.1	4.1
800	19.6	4.1
850	20.1	4.4
900	20.8	4.7
950	21.1	4.8
1000	21.6	4.9

cable loss 1 (inside chamber)	cable loss 2 (outside chamber)	cable loss 3 (switch unit)	cable loss 4 (to receiver)	distance corr. (-20 dB/decade)	d_{Limit} (meas. distance (limit))	d_{used} (meas. distance (used))
dB	dB	dB	dB	dB	m	m
0.29	0.04	0.23	0.02	0.0	3	3
0.39	0.09	0.32	0.08	0.0	3	3
0.56	0.14	0.47	0.08	0.0	3	3
0.73	0.20	0.59	0.12	0.0	3	3
0.84	0.21	0.70	0.11	0.0	3	3
0.98	0.24	0.80	0.13	0.0	3	3
1.04	0.26	0.89	0.15	0.0	3	3
1.18	0.31	0.96	0.13	0.0	3	3
1.28	0.35	1.03	0.19	0.0	3	3
1.39	0.38	1.11	0.22	0.0	3	3
1.44	0.39	1.20	0.19	0.0	3	3
1.55	0.46	1.24	0.23	0.0	3	3
1.59	0.43	1.29	0.23	0.0	3	3
1.67	0.34	1.35	0.22	0.0	3	3
1.67	0.42	1.41	0.15	0.0	3	3
1.87	0.54	1.46	0.25	0.0	3	3
1.90	0.46	1.51	0.25	0.0	3	3
1.99	0.60	1.56	0.27	0.0	3	3
2.14	0.60	1.63	0.29	0.0	3	3
2.22	0.60	1.66	0.33	0.0	3	3
2.23	0.61	1.71	0.30	0.0	3	3

($d_{Limit} = 10\text{ m}$)

30	18.6	-9.9
50	6.0	-9.6
100	9.7	-9.2
150	7.9	-8.8
200	7.6	-8.6
250	9.5	-8.3
300	11.0	-8.1
350	12.4	-7.9
400	13.6	-7.6
450	14.7	-7.4
500	15.6	-7.2
550	16.3	-7.0
600	17.2	-6.9
650	18.1	-6.9
700	18.5	-6.8
750	19.1	-6.3
800	19.6	-6.3
850	20.1	-6.0
900	20.8	-5.8
950	21.1	-5.6
1000	21.6	-5.6

0.29	0.04	0.23	0.02	-10.5	10	3
0.39	0.09	0.32	0.08	-10.5	10	3
0.56	0.14	0.47	0.08	-10.5	10	3
0.73	0.20	0.59	0.12	-10.5	10	3
0.84	0.21	0.70	0.11	-10.5	10	3
0.98	0.24	0.80	0.13	-10.5	10	3
1.04	0.26	0.89	0.15	-10.5	10	3
1.18	0.31	0.96	0.13	-10.5	10	3
1.28	0.35	1.03	0.19	-10.5	10	3
1.39	0.38	1.11	0.22	-10.5	10	3
1.44	0.39	1.20	0.19	-10.5	10	3
1.55	0.46	1.24	0.23	-10.5	10	3
1.59	0.43	1.29	0.23	-10.5	10	3
1.67	0.34	1.35	0.22	-10.5	10	3
1.67	0.42	1.41	0.15	-10.5	10	3
1.87	0.54	1.46	0.25	-10.5	10	3
1.90	0.46	1.51	0.25	-10.5	10	3
1.99	0.60	1.56	0.27	-10.5	10	3
2.14	0.60	1.63	0.29	-10.5	10	3
2.22	0.60	1.66	0.33	-10.5	10	3
2.23	0.61	1.71	0.30	-10.5	10	3

Sample calculation

$$E \text{ (dB } \mu\text{V/m)} = U \text{ (dB } \mu\text{V)} + \text{AF (dB 1/m)} + \text{Corr. (dB)}$$

U = Receiver reading

AF = Antenna factor

Corr. = sum of single correction factors of used cables, switch unit, distance correction, amplifier (if applicable)

distance correction = $-20 * \text{LOG} (d_{Limit} / d_{used})$

Linear interpolation will be used for frequencies in between the values in the table.

Tables show an extract of values.

6.4 ANTENNA R&S HF907 (1 GHZ – 18 GHZ)

Frequency MHz	AF R&S HF907 dB (1/m)	Corr. dB
1000	24.4	-19.4
2000	28.5	-17.4
3000	31.0	-16.1
4000	33.1	-14.7
5000	34.4	-13.7
6000	34.7	-12.7
7000	35.6	-11.0

cable loss 1 (relay + cable inside chamber) dB	cable loss 2 (outside chamber) dB	cable loss 3 (switch unit, atten- uator & pre-amp) dB	cable loss 4 (to receiver) dB
0.99	0.31	-21.51	0.79
1.44	0.44	-20.63	1.38
1.87	0.53	-19.85	1.33
2.41	0.67	-19.13	1.31
2.78	0.86	-18.71	1.40
2.74	0.90	-17.83	1.47
2.82	0.86	-16.19	1.46

Frequency MHz	AF R&S HF907 dB (1/m)	Corr. dB
3000	31.0	-23.4
4000	33.1	-23.3
5000	34.4	-21.7
6000	34.7	-21.2
7000	35.6	-19.8

cable loss 1 (relay inside chamber) dB	cable loss 2 (inside chamber) dB	cable loss 3 (outside chamber) dB	cable loss 4 (switch unit, atten- uator & pre-amp) dB	cable loss 5 (to receiver) dB	used for FCC 15.247
0.47	1.87	0.53	-27.58	1.33	
0.56	2.41	0.67	-28.23	1.31	
0.61	2.78	0.86	-27.35	1.40	
0.58	2.74	0.90	-26.89	1.47	
0.66	2.82	0.86	-25.58	1.46	

Frequency MHz	AF R&S HF907 dB (1/m)	Corr. dB
7000	35.6	-57.3
8000	36.3	-56.3
9000	37.1	-55.3
10000	37.5	-56.2
11000	37.5	-55.3
12000	37.6	-53.7
13000	38.2	-53.5
14000	39.9	-56.3
15000	40.9	-54.1
16000	41.3	-54.1
17000	42.8	-54.4
18000	44.2	-54.7

cable loss 1 (relay inside chamber) dB	cable loss 2 (High Pass) dB	cable loss 3 (pre- amp) dB	cable loss 4 (inside chamber) dB	cable loss 5 (outside chamber) dB	cable loss 6 (to receiver) dB
0.56	1.28	-62.72	2.66	0.94	1.46
0.69	0.71	-61.49	2.84	1.00	1.53
0.68	0.65	-60.80	3.06	1.09	1.60
0.70	0.54	-61.91	3.28	1.20	1.67
0.80	0.61	-61.40	3.43	1.27	1.70
0.84	0.42	-59.70	3.53	1.26	1.73
0.83	0.44	-59.81	3.75	1.32	1.83
0.91	0.53	-63.03	3.91	1.40	1.77
0.98	0.54	-61.05	4.02	1.44	1.83
1.23	0.49	-61.51	4.17	1.51	1.85
1.36	0.76	-62.36	4.34	1.53	2.00
1.70	0.53	-62.88	4.41	1.55	1.91

Sample calculation

$E \text{ (dB } \mu\text{V/m)} = U \text{ (dB } \mu\text{V)} + AF \text{ (dB 1/m)} + Corr. \text{ (dB)}$
 U = Receiver reading
 AF = Antenna factor
 Corr. = sum of single correction factors of used cables, switch unit, distance correction, amplifier (if applicable)
 Linear interpolation will be used for frequencies in between the values in the table.
 Tables show an extract of values.

6.5 ANTENNA EMCO 3160-09 (18 GHZ – 26.5 GHZ)

Frequency MHz	AF EMCO 3160-09 dB (1/m)	Corr. dB
18000	40.2	-23.5
18500	40.2	-23.2
19000	40.2	-22.0
19500	40.3	-21.3
20000	40.3	-20.3
20500	40.3	-19.9
21000	40.3	-19.1
21500	40.3	-19.1
22000	40.3	-18.7
22500	40.4	-19.0
23000	40.4	-19.5
23500	40.4	-19.3
24000	40.4	-19.8
24500	40.4	-19.5
25000	40.4	-19.3
25500	40.5	-20.4
26000	40.5	-21.3
26500	40.5	-21.1

cable loss 1 (inside chamber) dB	cable loss 2 (pre- amp) dB	cable loss 3 (inside chamber) dB	cable loss 4 (switch unit) dB	cable loss 5 (to receiver) dB
0.72	-35.85	6.20	2.81	2.65
0.69	-35.71	6.46	2.76	2.59
0.76	-35.44	6.69	3.15	2.79
0.74	-35.07	7.04	3.11	2.91
0.72	-34.49	7.30	3.07	3.05
0.78	-34.46	7.48	3.12	3.15
0.87	-34.07	7.61	3.20	3.33
0.90	-33.96	7.47	3.28	3.19
0.89	-33.57	7.34	3.35	3.28
0.87	-33.66	7.06	3.75	2.94
0.88	-33.75	6.92	3.77	2.70
0.90	-33.35	6.99	3.52	2.66
0.88	-33.99	6.88	3.88	2.58
0.91	-33.89	7.01	3.93	2.51
0.88	-33.00	6.72	3.96	2.14
0.89	-34.07	6.90	3.66	2.22
0.86	-35.11	7.02	3.69	2.28
0.90	-35.20	7.15	3.91	2.36

Sample calculation

$$E \text{ (dB } \mu\text{V/m)} = U \text{ (dB } \mu\text{V)} + AF \text{ (dB 1/m)} + Corr. \text{ (dB)}$$

U = Receiver reading

AF = Antenna factor

Corr. = sum of single correction factors of used cables, switch unit, distance correction, amplifier (if applicable)

Linear interpolation will be used for frequencies in between the values in the table.

Table shows an extract of values.

6.6 ANTENNA EMCO 3160-10 (26.5 GHZ – 40 GHZ)

Frequency GHz	AF EMCO 3160-10 dB (1/m)	Corr. dB	cable loss 1 (inside chamber) dB	cable loss 2 (outside chamber) dB	cable loss 3 (switch unit) dB	cable loss 4 (to receiver) dB	distance corr. (-20 dB/ decade) dB	d _{Limit} (meas. distance (limit) m	d _{used} (meas. distance (used) m
26.5	43.4	-11.2	4.4				-9.5	3	1.0
27.0	43.4	-11.2	4.4				-9.5	3	1.0
28.0	43.4	-11.1	4.5				-9.5	3	1.0
29.0	43.5	-11.0	4.6				-9.5	3	1.0
30.0	43.5	-10.9	4.7				-9.5	3	1.0
31.0	43.5	-10.8	4.7				-9.5	3	1.0
32.0	43.5	-10.7	4.8				-9.5	3	1.0
33.0	43.6	-10.7	4.9				-9.5	3	1.0
34.0	43.6	-10.6	5.0				-9.5	3	1.0
35.0	43.6	-10.5	5.1				-9.5	3	1.0
36.0	43.6	-10.4	5.1				-9.5	3	1.0
37.0	43.7	-10.3	5.2				-9.5	3	1.0
38.0	43.7	-10.2	5.3				-9.5	3	1.0
39.0	43.7	-10.2	5.4				-9.5	3	1.0
40.0	43.8	-10.1	5.5				-9.5	3	1.0

Sample calculation

$$E \text{ (dB } \mu\text{V/m)} = U \text{ (dB } \mu\text{V)} + AF \text{ (dB 1/m)} + Corr. \text{ (dB)}$$

U = Receiver reading

AF = Antenna factor

Corr. = sum of single correction factors of used cables, switch unit, distance correction, amplifier (if applicable)

Linear interpolation will be used for frequencies in between the values in the table.

distance correction = $-20 * \text{LOG} (d_{\text{Limit}} / d_{\text{used}})$

Linear interpolation will be used for frequencies in between the values in the table.

Table shows an extract of values.

7 MEASUREMENT UNCERTAINTIES

Test Case	Parameter	Uncertainty
AC Power Line	Power	± 3.4 dB
Field Strength of spurious radiation	Power	± 5.5 dB
6 dB / 26 dB / 99% Bandwidth	Power Frequency	± 2.9 dB ± 11.2 kHz
Conducted Output Power	Power	± 2.2 dB
Band Edge Compliance	Power Frequency	± 2.2 dB ± 11.2 kHz
Frequency Stability	Frequency	± 25 Hz
Power Spectral Density	Power	± 2.2 dB

8 PHOTO REPORT

Please see separate photo report.