

August 18, 2021

CalAmp Wireless Networks CA  
2200 Faraday Ave #220  
Carlsbad, CA 92008

Dear Imad Rizk,

Enclosed is the Wireless test report for compliance testing of the CalAmp Wireless Networks CA, SC1205V, as tested to the requirements of Title 47 of the CFR, Ch. 1 (10-1-06 ed.), Part 15 Subpart C for Intentional Radiators.

Thank you for using the services of Eurofins Electrical and Electronic Testing NA, Inc. Please contact me if you have any questions regarding these results or if Eurofins E&E can be of further service to you.

Sincerely,

*Rheine Nguyen*

Documentation Department  
Eurofins Electrical and Electronic Testing NA, Inc.

Reference: WIRS113743-FCC247 (BLE) Rev 1



Certificates and reports shall not be reproduced except in full, without the written permission of Eurofins Electrical and Electronic Testing NA, Inc. While use of the A2LA logo in this report reflects Eurofins Electrical and Electronic Testing NA, Inc. accreditation under these programs, the report must not be used by the client to claim product certification, approval, or endorsement by A2LA, or any agency of the Federal Government. This letter of transmittal is not a part of the attached report.

Eurofins Electrical and Electronic Testing NA, Inc. is part of the Eurofins Electrical & Electronics (E&E) global compliance network.

## **Electromagnetic Compatibility Criteria Test Report**

for the

**CalAmp Wireless Networks CA  
SC1205V**

**Tested under**  
the FCC Certification Rules  
contained in  
15.247 Subpart C for Intentional Radiators

**Report: WIR113743-FCC247 (BLE) Rev 1**

**Prepared For:**

**CalAmp Wireless Networks CA  
2200 Faraday Ave #220  
Carlsbad, CA 92008**

**Prepared By:**  
**Eurofins Electrical and Electronic Testing NA, Inc.**  
3162 Belick St.  
Santa Clara, CA 95054

## Electromagnetic Compatibility Criteria Test Report

for the

**CalAmp Wireless Networks CA  
SC1205V**

**Tested under**  
the FCC Certification Rules  
contained in  
15.247 Subpart C for Intentional Radiators



Arsalan Hasan  
Project Engineer, Electromagnetic Compatibility Lab

**Engineering Statement:** The measurements shown in this report were made in accordance with the procedures indicated, and the emissions from this equipment were found to be within the limits applicable. I assume full responsibility for the accuracy and completeness of these measurements, and for the qualifications of all persons taking them. It is further stated that upon the basis of the measurements made, the equipment tested is capable of operation in accordance with the requirements of the FCC Rules Part 15.247 under normal use and maintenance.

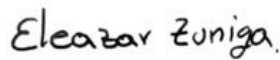

Eleazar Zuniga,  
Director, Wireless Laboratory

## Report Status Sheet

Revision	Report Date	Reason for Revision
∅	August 15, 2021	Initial Issue
1	August 18, 2021	TCB Review Updates

## Table of Contents

<b>I.</b>	<b>Executive Summary .....</b>	<b>1</b>
	A. Purpose of Test .....	2
	B. Executive Summary .....	2
<b>II.</b>	<b>Equipment Configuration .....</b>	<b>3</b>
	A. Overview .....	4
	B. References.....	5
	C. Test Site .....	5
	D. Measurement Uncertainty .....	5
	E. Description of Test Sample.....	6
	F. Modifications .....	7
	a) Modifications to EUT.....	7
	b) Modifications to Test Standard.....	7
	G. Disposition of EUT .....	7
<b>III.</b>	<b>Electromagnetic Compatibility Criteria for Intentional Radiators.....</b>	<b>8</b>
	§ 15.203 Antenna Requirement.....	8
	§ 15.209 Conducted Emissions Voltage.....	9
	§ 15.247(a)(a) 6 dB and 99% Bandwidth .....	10
	§ 15.247(b) Peak Power Output .....	12
	§ 15.247(d) Radiated Spurious Emissions Requirements and Band Edge.....	14
	§ 15.247(c) Spurious Emissions in Non-restricted Bands .....	21
	§ 15.247(e) Peak Power Spectral Density .....	27
<b>IV.</b>	<b>Test Equipment .....</b>	<b>29</b>

# I. Executive Summary

**A. Purpose of Test**

An EMC evaluation was performed to determine compliance of the CalAmp Wireless Networks CA, SC1205V, with the requirements of Part 15, §15.247. All references are to the most current version of Title 47 of the Code of Federal Regulations in effect. In accordance with §2.1033, the following data is presented in support of the Certification of the SC1205V. CalAmp Wireless Networks CA should retain a copy of this document which should be kept on file for at least two years after the manufacturing of the SC1205V, has been **permanently** discontinued.

**B. Executive Summary**

The following tests were conducted on a sample of the equipment for the purpose of demonstrating compliance with Part 15, §15.247, in accordance with CalAmp Wireless Networks CA, purchase order number 404965. All tests were conducted using measurement procedure ANSI C63.10-2013.

References	Description	Compliance
Title 47 of the CFR, Part 15 §15.203	Antenna Requirement	Compliant
Title 47 of the CFR, Part 15 §15.207(a)	Conducted Emissions Voltage	Not Applicable
Title 47 of the CFR, Part 15 §15.247(a)(2)	6dB Occupied Bandwidth	Compliant
Title 47 of the CFR, Part 15 §15.247(b)	Peak Power Output	Compliant
Title 47 of the CFR, Part 15 §15.247(c)	Spurious Emissions in Non-restricted Bands	Compliant
Title 47 of the CFR, Part 15 §15.247(d); §15.209; §15.205	Radiated Spurious Emissions Requirements	Compliant
Title 47 of the CFR, Part 15; §15.247(e)	Peak Power Spectral Density	Compliant

**Executive Summary of FCC Part 15.247 Compliance Testing**

## II. Equipment Configuration



## A. Overview

Eurofins Electrical and Electronic Testing NA, Inc. was contracted by CalAmp Wireless Networks CA to perform testing on the SC1205V, under purchase order number 404965.

This document describes the test setups, test methods, required test equipment, and the test limit criteria used to perform compliance testing of CalAmp Wireless Networks CA, SC1205V.

The results obtained relate only to the item(s) tested.

<b>Model(s) Tested:</b>	SC1205V	
<b>Model(s) Covered:</b>	SC1205V	
<b>Filing Status:</b>	Original	
<b>EUT Specifications:</b>	<b>Primary Power:</b>	
	Voltage: 12 V	
	AC or DC: DC	
	Voltage Frequency: NA	
	Number of Phases: 1	
	Current: 0.5 Amp	
	Type of Modulations:	GFSK
	Equipment Code:	DTS
	Technology	TX Frequency Range
	BLE	2402 - 2480 MHz
<b>Analysis:</b>	The results obtained relate only to the item(s) tested.	
<b>Environmental Test Conditions:</b>	Temperature: 15-35° C	
	Relative Humidity: 30-60%	
	Barometric Pressure: 860-1060 mbar	
<b>Duty Cycle for Testing:</b>	100%	
<b>Evaluated by:</b>	Arsalan Hasan	
<b>Date(s):</b>	August 18, 2021	

**EUT Summary Table**

## B. References

<b>CFR 47, Part 15, Subpart C</b>	Federal Communication Commission, Code of Federal Regulations, Title 47, Part 15: General Rules and Regulations, Allocation, Assignment, and Use of Radio Frequencies
<b>RSS-247</b>	Digital Transmission Systems (DTSs), Frequency Hopping Systems (FHSs) and License-Exempt Local Area Network (LE-LAN) Devices
<b>ANSI C63.4:2014</b>	Methods and Measurements of Radio-Noise Emissions from Low-Voltage Electrical And Electronic Equipment in the Range of 9 kHz to 40 GHz
<b>ISO/IEC 17025:2017</b>	General Requirements for the Competence of Testing and Calibration Laboratories
<b>ANSI C63.10-2013</b>	American National Standard for Testing Unlicensed Wireless Devices
<b>KDB 558074 v05r02</b>	Guidance For Performing Compliance Measurements On Digital Transmission Systems (DTS) Operating Under Section 15.247

### References

## C. Test Site

All testing was performed at Eurofins Electrical and Electronic Testing NA, Inc., 3162 Belick St., Santa Clara, CA 95054. All equipment used in making physical determinations is accurate and bears recent traceability to the National Institute of Standards and Technology.

Radiated Emissions measurements were performed in a 10 meter semi-anechoic chamber (equivalent to an Open Area Test Site). In accordance with §2.948(a)(3), a complete site description is contained at Eurofins Electrical and Electronic Testing NA, Inc.

Eurofins Electrical and Electronics Testing NA, Inc. is an ISO/IEC 17025 accredited site by A2LA, California #0591.02.

## D. Measurement Uncertainty

Test Method	Typical Expanded Uncertainty	K	Confidence Level
<b>Radiated Emissions, (30 MHz – 1 GHz)</b>	±3.24	2	95%
<b>Radiated Emissions, (1 GHz – 6 GHz)</b>	±3.92	2	95%
<b>Conducted Emission Voltage</b>	±2.44	2	95%
<b>RF Frequencies</b>	±4.52 Hz	2	95%
<b>RF Power Conducted Emissions</b>	±2.32 dB	2	95%
<b>RF Power Conducted Spurious Emissions</b>	±2.25 dB	2	95%
<b>RF Power Radiated Emissions</b>	±3.01 dB	2	95%

### Uncertainty Calculations Summary

## E. Description of Test Sample

<b>Name of EUT/Model:</b>	SC1205V
<b>Description of EUT and its intended use:</b>	The EUT is an asset tracker.
<b>Selected Operation Mode(s):</b>	The EUT radio is control by external software via a laptop.
<b>Rationale for the selection of the Operation Mode(s):</b>	This is the preferred mode of controlling the radio.
<b>Monitoring Method(s):</b>	Signals are displayed on a spectrum analyzer.
<b>Emissions Class Declaration:</b>	Class A
<b>Configuration(s):</b>	NA
<b>EUT Power Requirement</b>	
<b>Voltage:</b>	12 VDC (Vehicle battery powered)
<b>AC or DC:</b>	DC
<b>Voltage Frequency:</b>	NA
<b>Number of Phases:</b>	NA
<b>Current:</b>	0.5 A
<b>Physical Description</b>	
<b>EUT Arrangement:</b>	Table Top
<b>System with Multiple Chassis?</b>	NA
<b>Size (HxWxD - inches):</b>	30mm x 80mm x 140mm
<b>Weight (lbs):</b>	0.5 lbs
<b>Other Info</b>	
<b>EUT Software (internal to EUT):</b>	Rev 1
<b>Support Software (used by support PC to exercise EUT):</b>	The EUT is controlled by scripts for the Nordic BLE chip. The scripts are run over a serial connection via Tera Term.  Power setting: Low Channel: 0 Mid Channel: 0 High Channel: 0
<b>Firmware:</b>	Rev 1
<b>Transmitter Parameters</b>	
<b>Description of your unit:</b>	BLE
<b>Modulation Type:</b>	GFSK
<b>Number of Channels:</b>	NA
<b>Frequency range (MHz):</b>	2402 MHz –2480 MHz
<b>Antenna Type:</b>	PCB Trace
<b>Antenna Gain (dBi):</b>	0.5 dBi
<b>PMN:</b>	NA
<b>HVIN:</b>	NA
<b>FVIN:</b>	NA
<b>HMN:</b>	NA
<b>Data Rates:</b>	NA
<b>Expected Power Level:</b>	0 dBm (Conducted)
<b>Number of Antenna:</b>	1

**EUT List**

Ref. ID	Slot #	Name/Description	Model Number	Part Number	Serial Number	Rev. #
1	NA	SC1205V	SC1205V	NA	NA	1

**Ports and Cabling**

Ref. Id	Port Name on EUT	Cable Description or reason for no cable	Qty	Length as tested (m)	Max Length (m)	Shielded? (Y/N)	Termination Box ID & Port Name
NA	Serial Port	Debug Cable	1	NA	NA	N	NA

**Support Equipment**

Ref. ID	Name/Description	Manufacturer	Model Number	Customer Supplied Calibration Data
NA	Laptop	Dell	NA	NA

**F. Modifications**
**a) Modifications to EUT**

No modifications were made to the EUT.

**b) Modifications to Test Standard**

No modifications were made to the test standard.

**G. Disposition of EUT**

The test sample including all support equipment (if any), submitted to the Electromagnetic Compatibility Lab for testing was returned to CalAmp Wireless Networks CA upon completion of testing.

## Electromagnetic Compatibility Criteria for Intentional Radiators

### § 15.203 Antenna Requirement

**Test Requirement:** § 15.203: An intentional radiator shall be designed to ensure that no antenna other than that furnished by the responsible party shall be used with the device. The use of a permanently attached antenna or of an antenna that uses a unique coupling to the intentional radiator shall be considered sufficient to comply with the provisions of this section. The manufacturer may design the unit so that a broken antenna can be replaced by the user, but the use of a standard antenna jack or electrical connector is prohibited.

The structure and application of the EUT were analyzed to determine compliance with Section 15.203 of the Rules. Section 15.203 states that the subject device must meet at least one of the following criteria:

- a.) Antenna must be permanently attached to the unit.
- b.) Antenna must use a unique type of connector to attach to the EUT.
- c.) Unit must be professionally installed. Installer shall be responsible for verifying that the correct antenna is employed with the unit.

**Test Results:** The EUT was tested is **compliant** with § 15.203 Antenna Requirement.

**Test Engineer:** Arsalan Hasan

**Test Date:** 08/10/2021

Manufacturer	Peak Gain	Type	Polarization	Impedance
CalAmp	0.5 dBi	PCB Trace	Linear	50 Ω

### Antenna Requirement

## Electromagnetic Compatibility Criteria for Intentional Radiators

### § 15.207(a) Conducted Emissions Limits

**Test Requirement(s):** § 15.207 (a): For an intentional radiator that is designed to be connected to the public utility (AC) power line, the radio frequency voltage that is conducted back onto the AC power line on any frequency or frequencies, within the band 150 kHz to 30MHz, shall not exceed the limits in the following table, as measured using a 50  $\mu$ H/50  $\Omega$  line impedance stabilization network (LISN). Compliance with the provisions of this paragraph shall be based on the measurement of the radio frequency voltage between each power line and ground at the power terminal. The lower limit applies at the boundary between the frequency ranges.

Frequency range (MHz)	§ 15.207(a), Conducted Limit (dB $\mu$ V)	
	Quasi-Peak	Average
* 0.15- 0.5	66 - 56	56 - 46
0.5 - 5	56	46
5 - 30	60	50

#### Conducted Limits for Intentional Radiators from FCC Part 15 § 15.207(a)

**Test Procedure:** The EUT was placed on a 0.8 m-high wooden table inside a screen room. The EUT was situated such that the back of the EUT was 0.4 m from one wall of the vertical ground plane, and the remaining sides of the EUT were no closer than 0.8 m from any other conductive surface. The EUT was powered from a 50  $\Omega$ /50  $\mu$ H Line Impedance Stabilization Network (LISN). The EMC receiver scanned the frequency range from 150 kHz to 30 MHz. Conducted Emissions measurements were made in accordance with *ANSI C63.10-2013*. The measurements were performed over the frequency range of 0.15 MHz to 30 MHz using a 50  $\Omega$ /50  $\mu$ H LISN as the input transducer to an EMC/field intensity meter.

**Test Results:** The EUT was not applicable with this requirement. EUT is DC powered.

## Electromagnetic Compatibility Criteria for Intentional Radiators

### § 15.247(a)(2) 6 dB Bandwidth

**Test Requirements:** § 15.247(a)(2): Operation under the provisions of this section is limited to frequency hopping and digitally modulated intentional radiators that comply with the following provisions:

For systems using digital modulation techniques, the EUT may operate in the 902-928 MHz, 2400-2483.5 MHz and 5725-5850 MHz bands. The minimum 6dB bandwidth shall be at least 500 kHz.

**Test Procedure:** The EUT was connected to a spectrum analyzer through a cable and an attenuator. Measurements were taken with the EUT set to transmit continuously on its low, mid, and high channels for all its bandwidths. The 6dB bandwidth was measured according to measurement method 11.8.2 Option 2 of ANSI C63.10-2013.

**Test Results** The EUT was compliant with § 15.247 (a)(2).

**Test Engineer(s):** Arsalan Hasan

**Test Date(s):** 08/10/2021

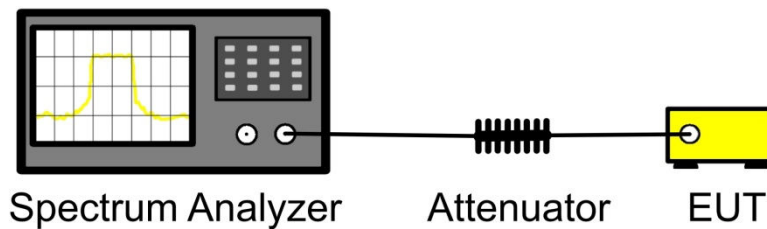

**Block Diagram, Occupied Bandwidth Test Setup**

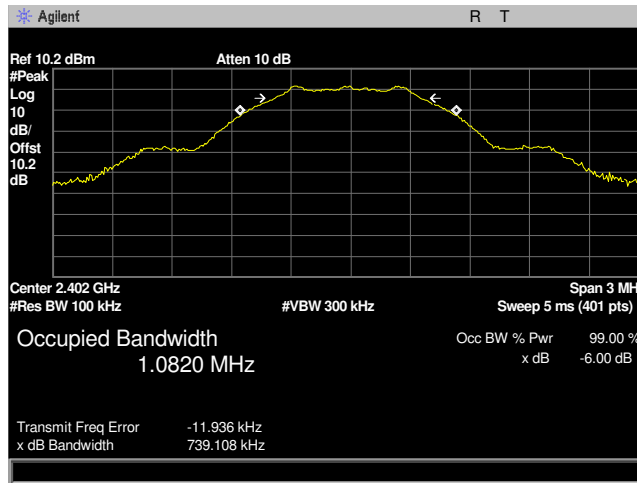

6dB Bandwidth, Low Channel, 2402MHz

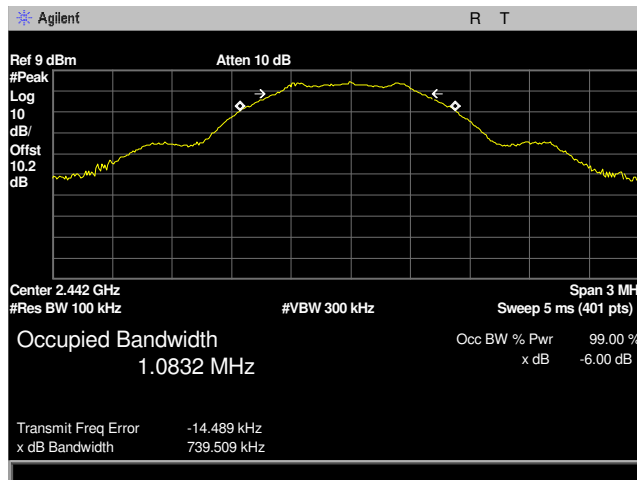

6dB Bandwidth, Mid Channel, 2442MHz

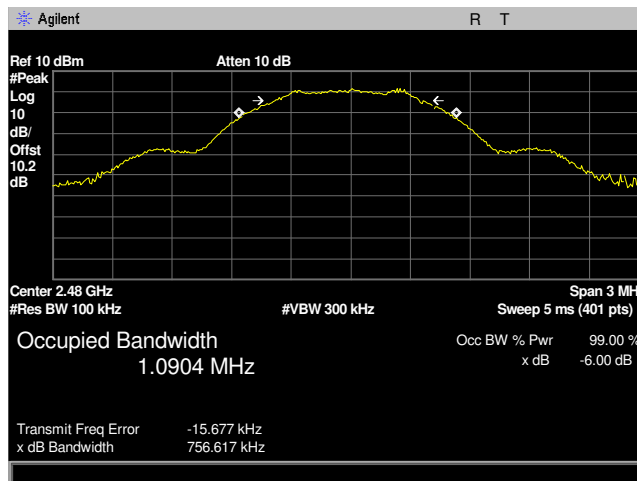

6dB Bandwidth, High Channel, 2480MHz



## Electromagnetic Compatibility Criteria for Intentional Radiators

### § 15.247(b) Conducted Power Output

**Test Requirements:** §15.247(b): The maximum peak output power of the intentional radiator shall not exceed the following:

§15.247(b)(3): For systems using digital modulation in the 902-928 MHz, 2400-2483.5 MHz, and 5725-5850 MHz bands: 1 Watt. As an alternative to a peak power measurement, compliance with the one Watt limit can be based on a measurement of the maximum conducted output power. Maximum Conducted Output Power is defined as the total transmit power delivered to all antennas and antenna elements averaged across all symbols in the signaling alphabet when the transmitter is operating at its maximum power control level. Power must be summed across all antennas and antenna elements. The average must not include any time intervals during which the transmitter is off or is transmitting at a reduced power level. If multiple modes of operation are possible (e.g., alternative modulation methods), the maximum conducted output power is the highest total transmit power occurring in any mode.

§15.247(c)(4): The conducted output power limit specified in paragraph (b) of this section is based on the use of antennas with directional gains that do not exceed 6 dBi. Except as shown in paragraph (c) of this section, if transmitting antennas of directional gain greater than 6 dBi are used, the conducted output power from the intentional radiator shall be reduced below the stated values in paragraphs (b)(1), (b)(2), and (b)(3) of this section, as appropriate, by the amount in dB that the directional gain of the antenna exceeds 6 dBi.

**Test Procedure:** The EUT was connected to a spectrum analyzer through a cable and an attenuator. Measurements were taken with the EUT set to transmit continuously on its low, mid, and high channels for all its bandwidths at maximum power. Power was measured according to measurement method AVGSA-2, as described in ANSI C63.10-2013, section 11.9.2.2.4. Attenuator, cable loss, and duty factor were programmed into the spectrum analyzer.

**Test Results:** The EUT was compliant with the Peak Power Output limits of §15.247(b).

**Test Engineer(s):** Arsalan Hasan

**Test Date(s):** 08/10/2021

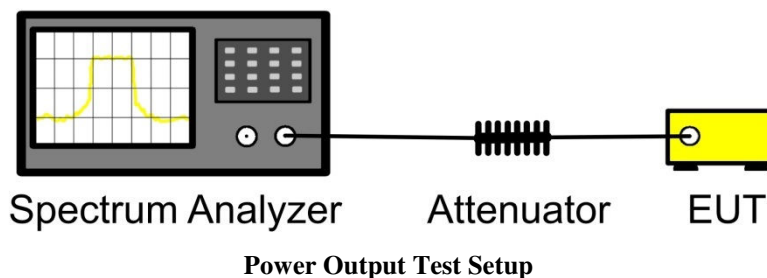

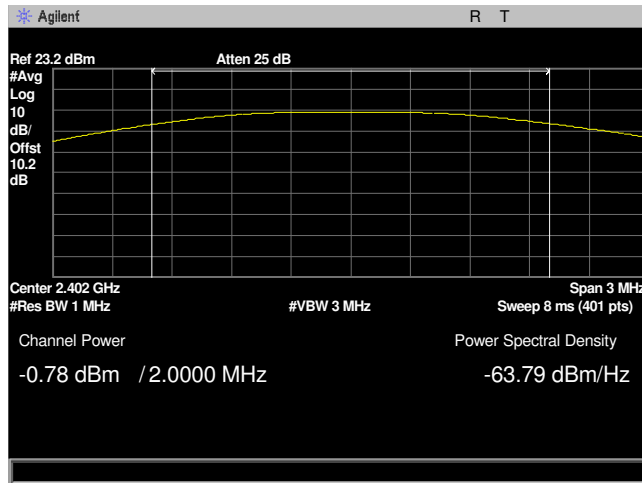

Output Power, Low Channel, 2402MHz

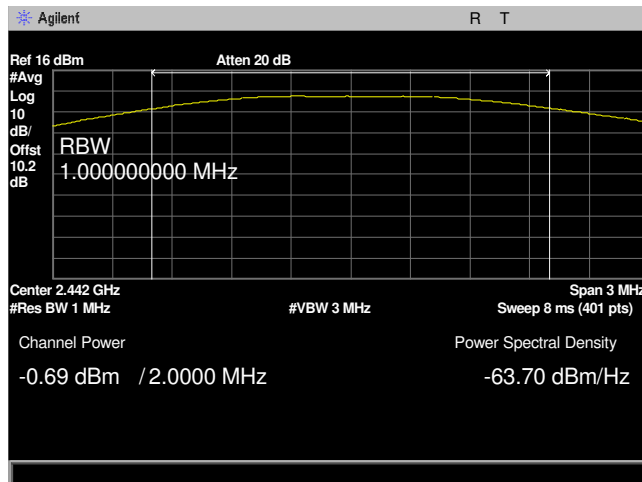

Output Power, Mid Channel, 2442MHz

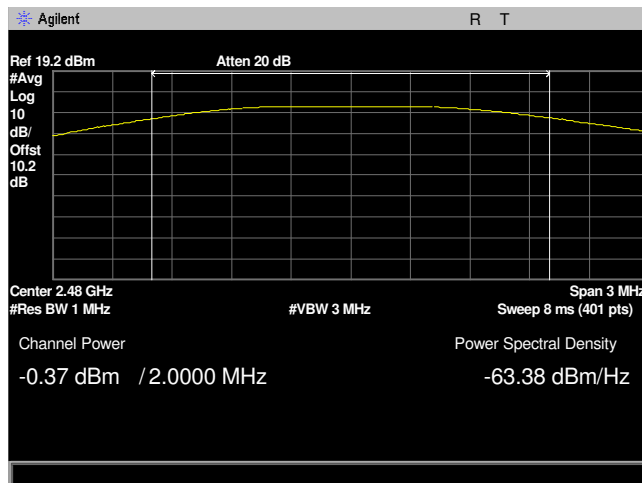

Output Power, High Channel, 2480MHz

**Electromagnetic Compatibility Criteria for Intentional Radiators**

**§ 15.209 Radiated Spurious Emissions Requirements and Band Edge**

**Test Requirements:** §15.247(d); §15.205: Emissions outside the frequency band.

§15.205(a): Except as shown in paragraph (d) of this section, only spurious emissions are permitted in any of the frequency bands listed below:

MHz	MHz	MHz	GHz
0.090–0.110-----	16.42–16.423	399.9–410	4.5–5.15
<sup>1</sup> 0.495–0.505-----	16.69475–16.69525	608–614	5.35–5.46
2.1735–2.1905-----	16.80425–16.80475	960–1240	7.25–7.75
4.125–4.128-----	25.5–25.67	1300–1427	8.025–8.5
4.17725–4.17775-----	37.5–38.25	1435–1626.5	9.0–9.2
4.20725–4.20775-----	73–74.6	1645.5–1646.5	9.3–9.5
6.215–6.218-----	74.8–75.2	1660–1710	10.6–12.7
6.26775–6.26825-----	108–121.94	1718.8–1722.2	13.25–13.4
6.31175–6.31225-----	123–138	2200–2300	14.47–14.5
8.291–8.294-----	149.9–150.05	2310–2390	15.35–16.2
8.362–8.366-----	156.52475–156.52525	2483.5–2500	17.7–21.4
8.37625–8.38675-----	156.7–156.9	2655–2900	22.01–23.12
8.41425–8.41475-----	162.0125–167.17	3260–3267	23.6–24.0
12.29–12.293-----	167.72–173.2	3332–3339	31.2–31.8
12.51975–12.52025-----	240–285	3345.8–3358 36.	43–36.5
12.57675–12.57725-----	322–335.4	3600–4400	( <sup>2</sup> )

**Restricted Bands of Operation**

<sup>1</sup> Until February 1, 1999, this restricted band shall be 0.490 – 0.510 MHz.

<sup>2</sup> Above 38.6

**Test Requirement(s):** § 15.209 (a): Except as provided elsewhere in this subpart, the emissions from an intentional radiator shall not exceed the field strength levels specified in table.

Frequency (MHz)	§ 15.209(a), Radiated Emission Limits (dBμV) @ 3m
30 - 88	40.00
88 - 216	43.50
216 - 960	46.00
Above 960	54.00

**Radiated Emissions Limits Calculated from FCC Part 15, § 15.209 (a)**

**Test Procedures:** The transmitter was turned on. Measurements were performed of the low, mid and high Channels. The EUT was rotated orthogonally through all three axes. Plots shown are corrected for both antenna correction factor and distance and compared to a 3 m limit line. Only noise floor was measured above 18 GHz.

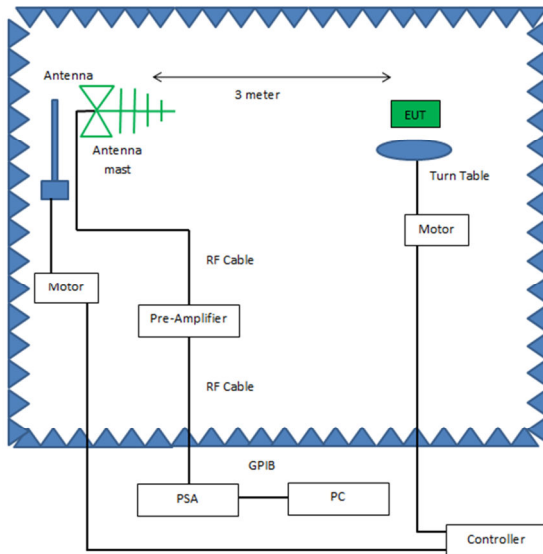

**Radiated Emissions, Below 1GHz, Test Setup**

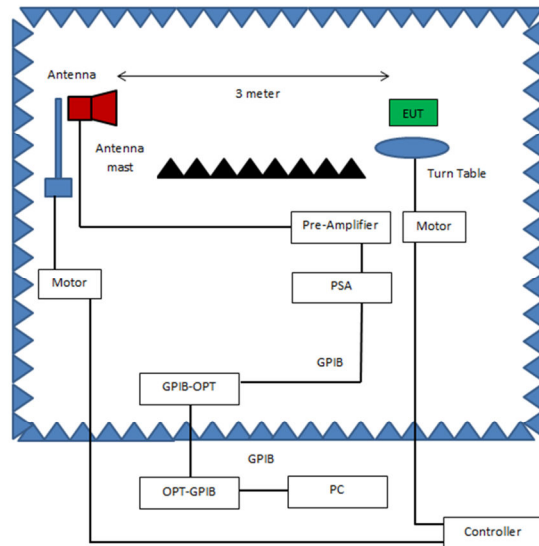

**Radiated Emissions, Above 1GHz, Test Setup**

**Test Results:** The EUT was tested is **compliant** with § 15.209 Radiated Spurious Emissions Requirements and Band Edge.

**Test Engineer:** Arsalan Hasan

**Test Date:** 08/10/2021

**Test Data**

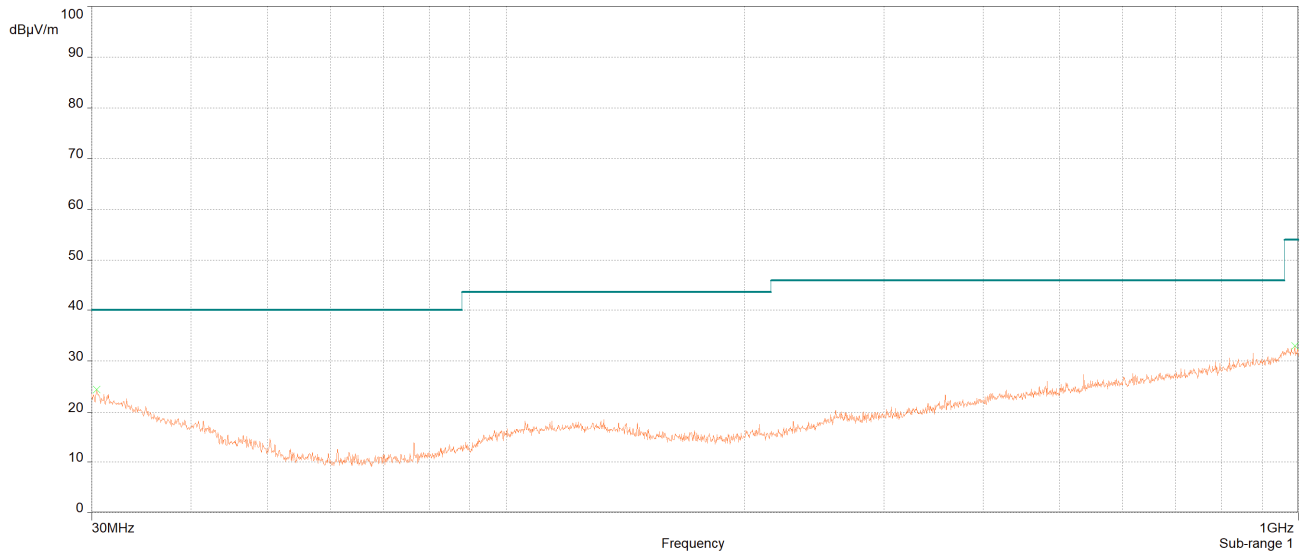

**Radiated Spurious Emissions, 30MHz-1GHz, Worst Case**

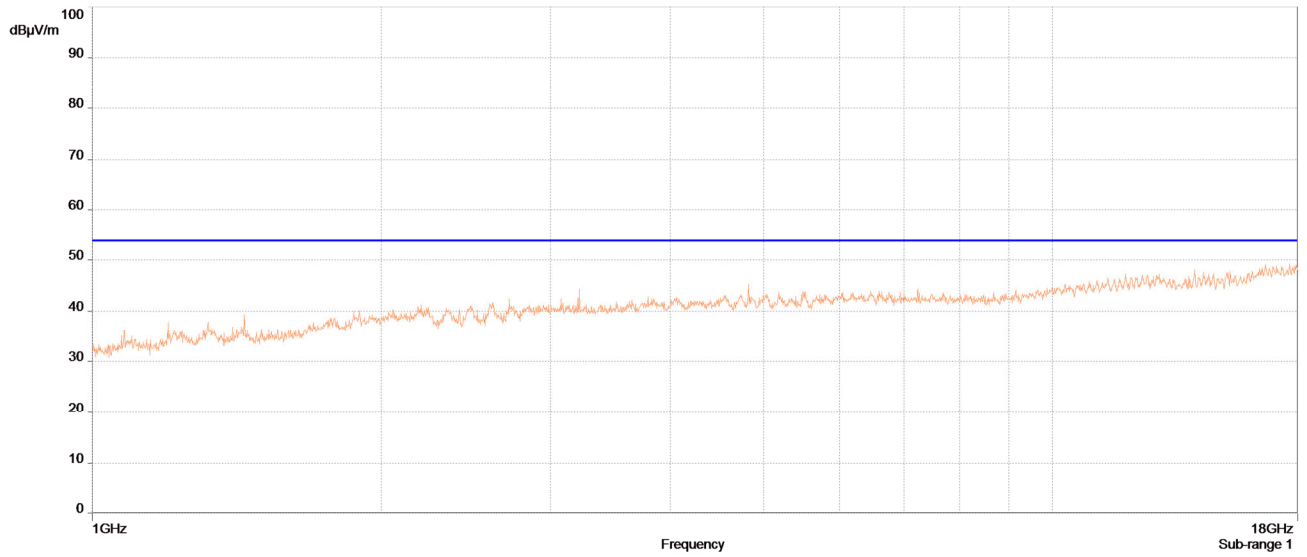

**Radiated Spurious Emissions, 1GHz-18GHz, Low Channel, Average**

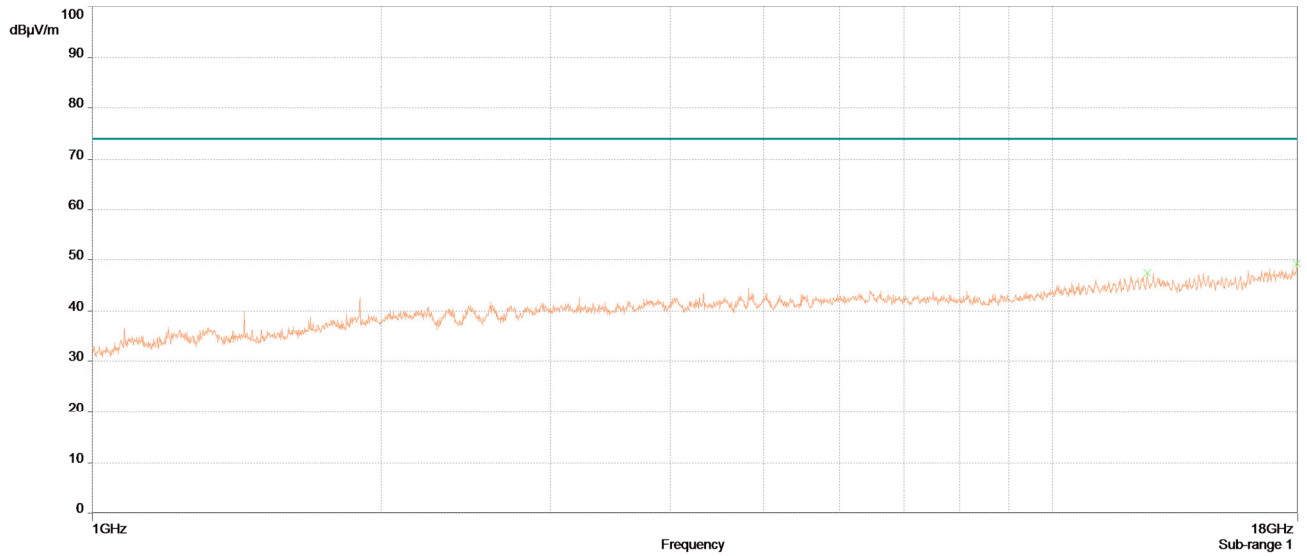

**Radiated Spurious Emissions, 1GHz-18GHz, Low Channel, Peak**

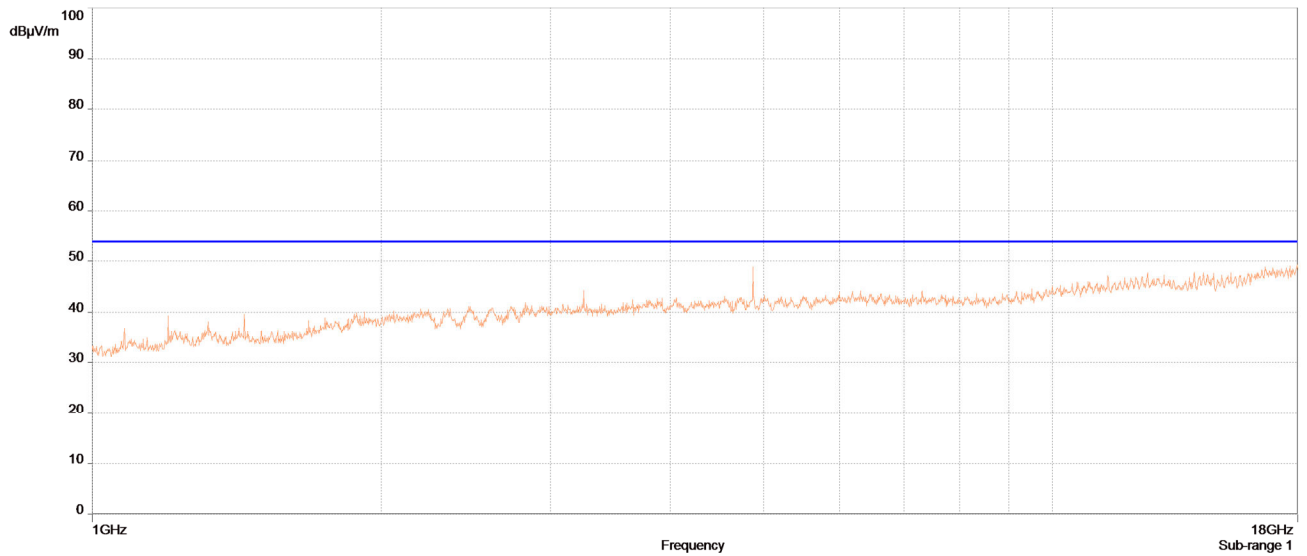

**Radiated Spurious Emissions, 1GHz-18GHz, Mid Channel, Average**

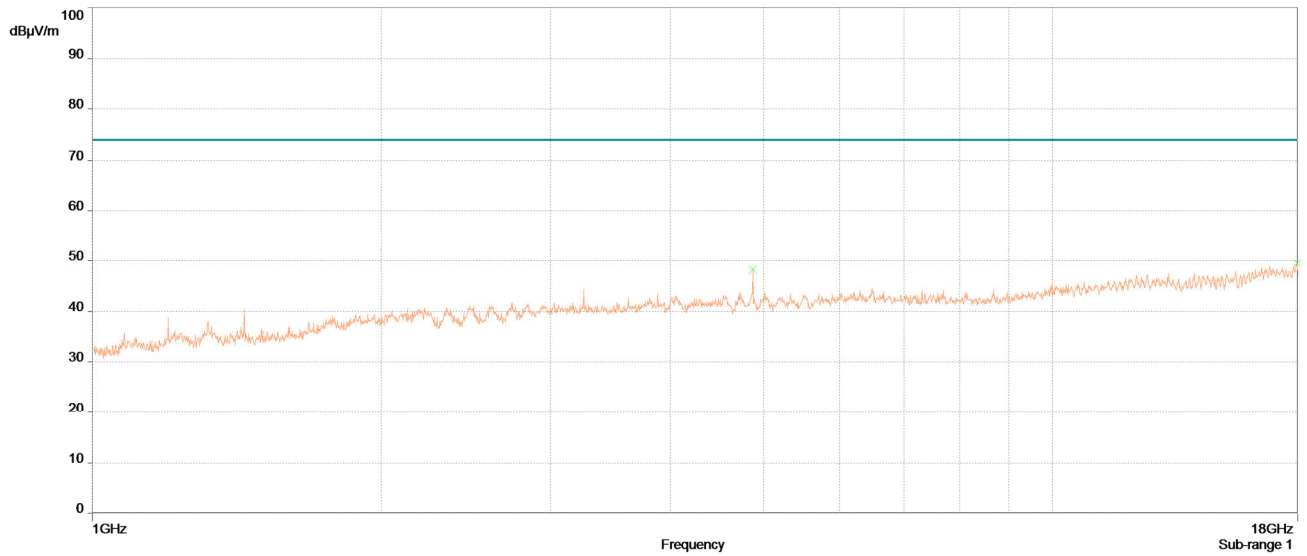

**Radiated Spurious Emissions, 1GHz-18GHz, Mid Channel, Peak**

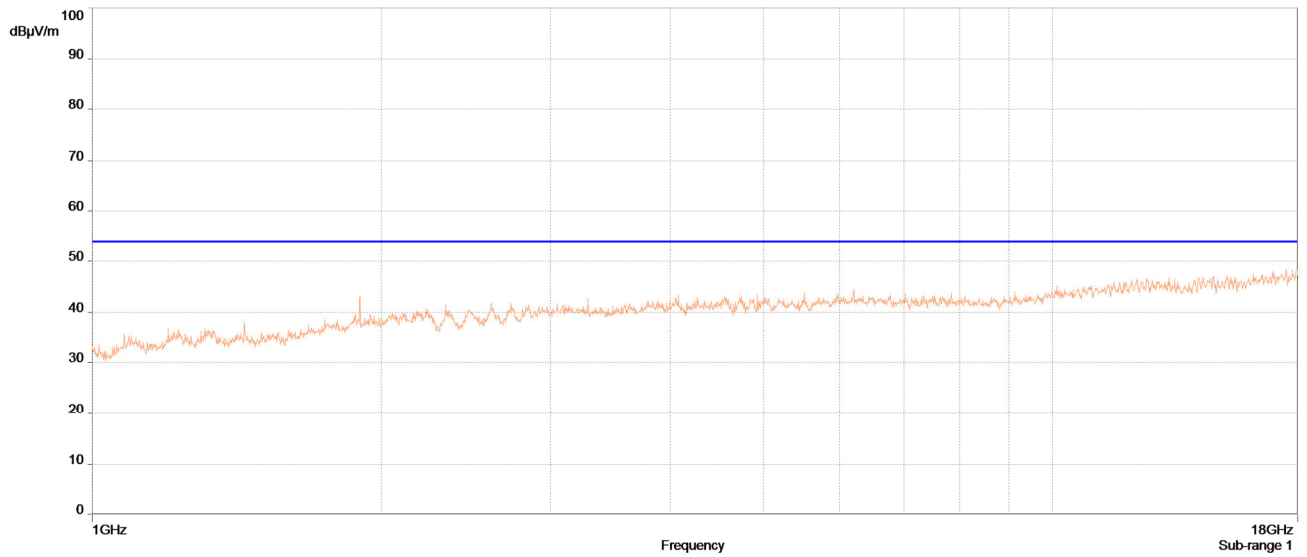

**Radiated Spurious Emissions, 1GHz-18GHz, High Channel, Average**

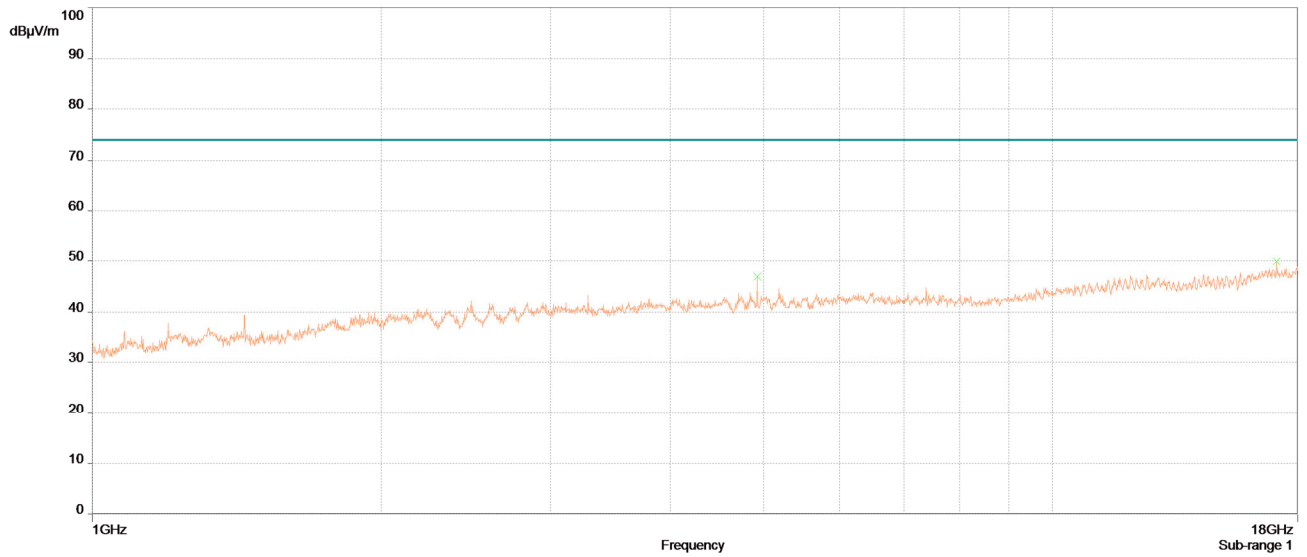

**Radiated Spurious Emissions, 1GHz-18GHz, High Channel, Peak**



## Radiated Band Edge Measurements

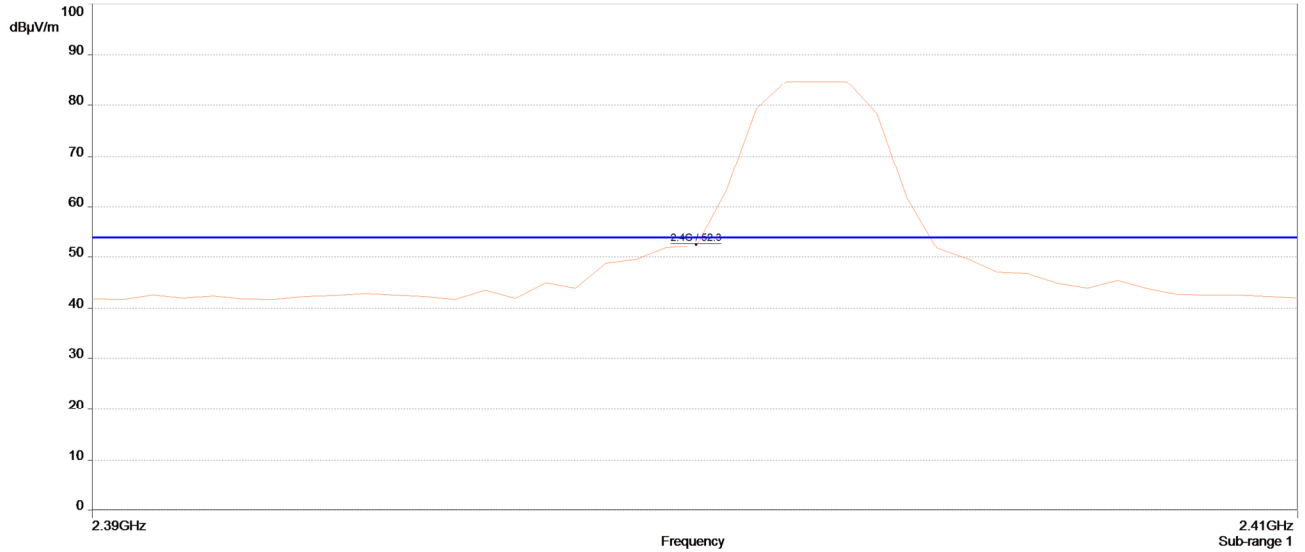

### Radiated BandEdge, Low Channel, Average

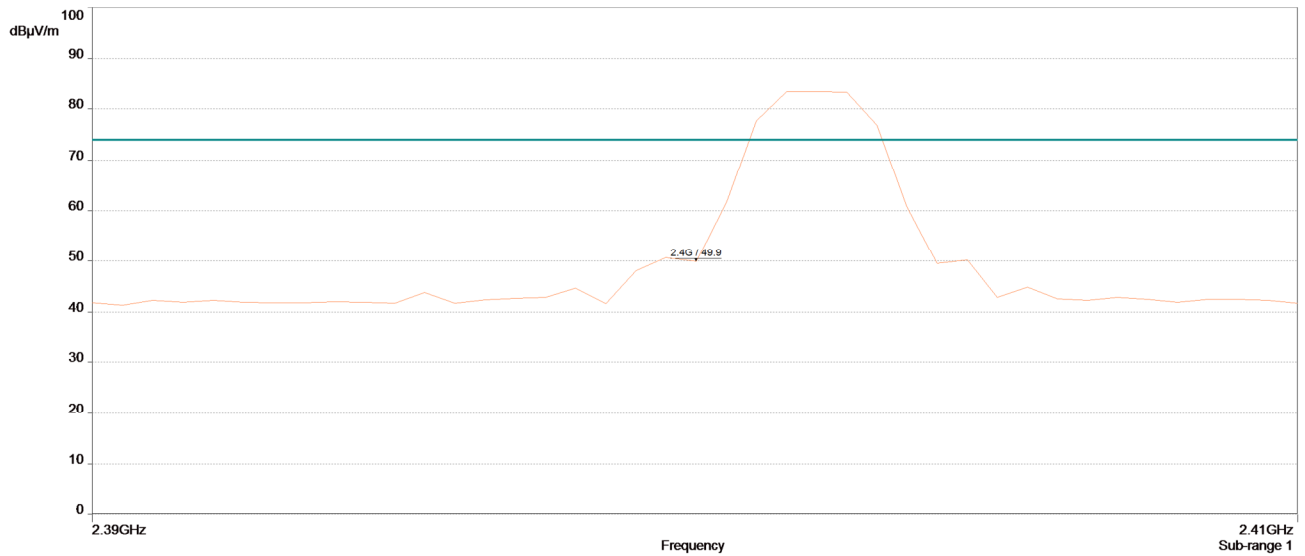

### Radiated BandEdge, Low Channel, Peak

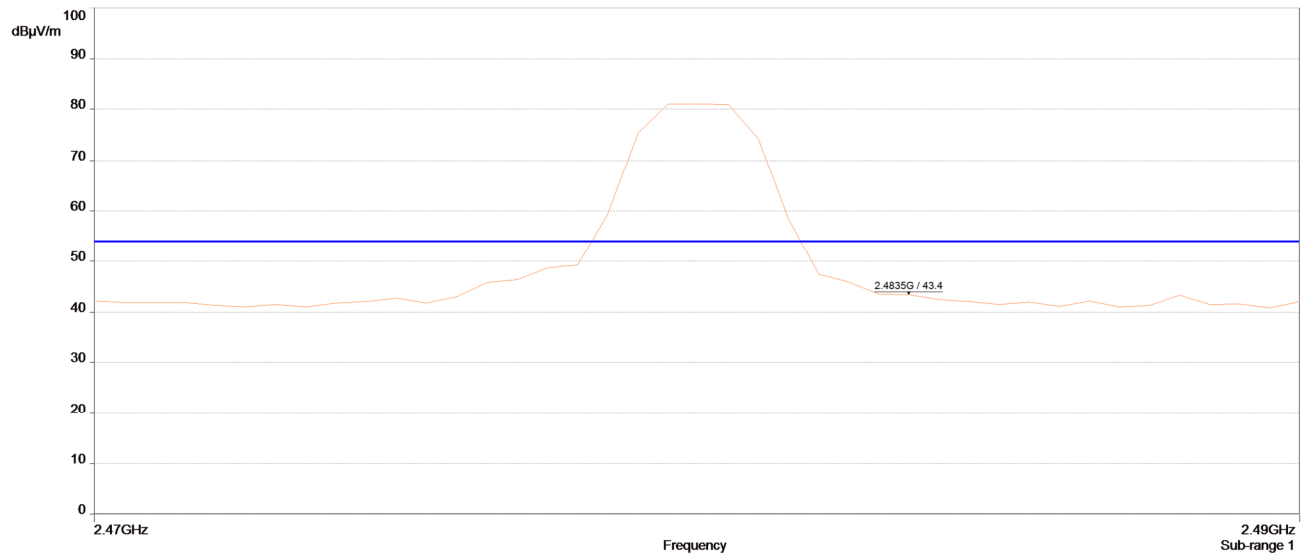

**Radiated BandEdge, High Channel, Average**

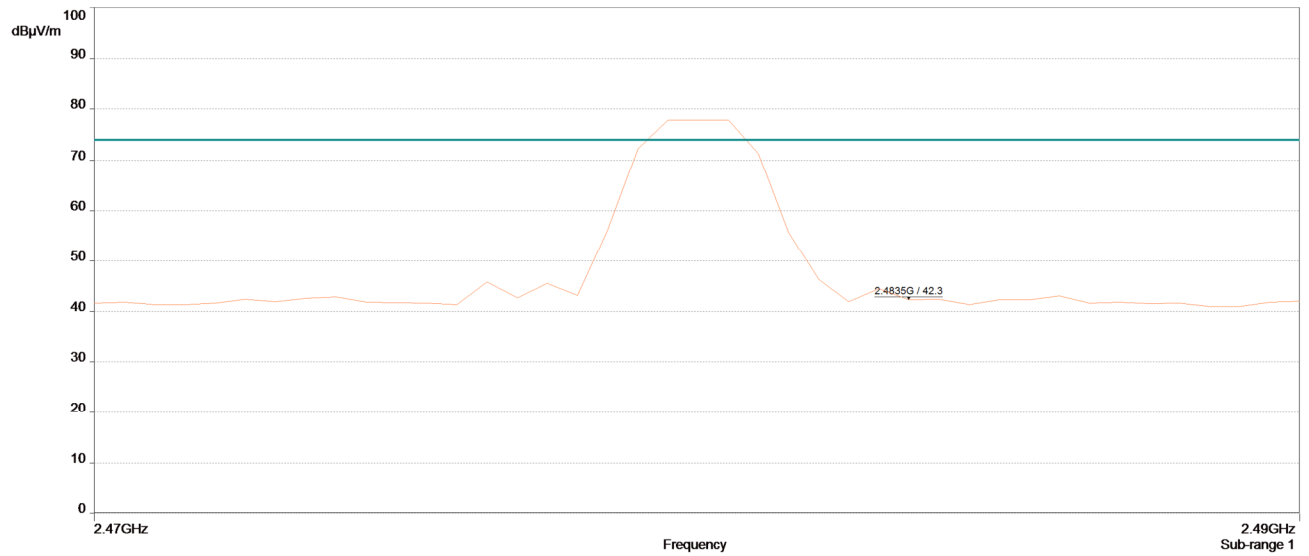

**Radiated BandEdge, High Channel, Peak**

## Electromagnetic Compatibility Criteria for Intentional Radiators

### § 15.247(d) Spurious Emissions in Non-restricted Bands

**Test Requirement:** **15.247(d)** In any 100 kHz bandwidth outside the frequency band in which the spread spectrum or digitally modulated intentional radiator is operating, the radio frequency power that is produced by the intentional radiator shall be at least 20 dB below that in the 100 kHz bandwidth within the band that contains the highest level of the desired power, based on either an RF conducted or a radiated measurement, provided the transmitter demonstrates compliance with the peak conducted power limits. If the transmitter complies with the conducted power limits based on the use of RMS averaging over a time interval, as permitted under paragraph (b)(3) of this section, the attenuation required under this paragraph shall be 30 dB instead of 20 dB.

**Test Procedure:** For intentional radiators with a digital device portion which operates below 10 GHz, the spectrum was investigated as per §15.33(a)(1) and §15.33(a)(4); i.e., the lowest RF signal generated or used in the device up to the 10<sup>th</sup> harmonic of the highest fundamental frequency or to 40 GHz, whichever is lower.

The EUT was connected to a spectrum analyzer through a cable and an attenuator. Measurements were taken with the EUT set to transmit continuously on its low, mid, and high channels for all its bandwidths at maximum power. Conducted spurious emissions were measured according to sections 11.11.2 and 11.11.3 of ANSI C63.10-2013.

**Test Results:** The EUT was compliant with the Spurious Emission limits of §15.247(d).

**Test Engineer(s):** Arsalan Hasan

**Test Date(s):** 08/10/2021

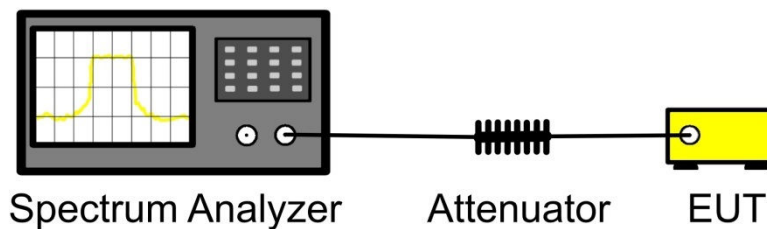

**Conducted Spurious Emissions**

Test Data

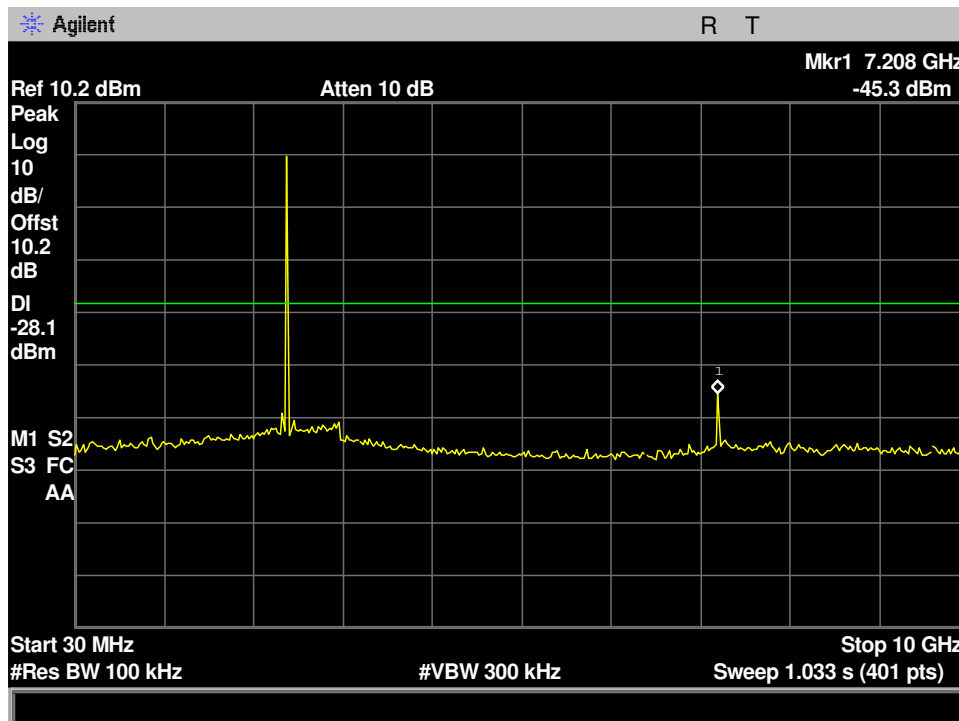

Conducted Spurious Emissions, 30MHz-10GHz, Low Channel, 2402MHz

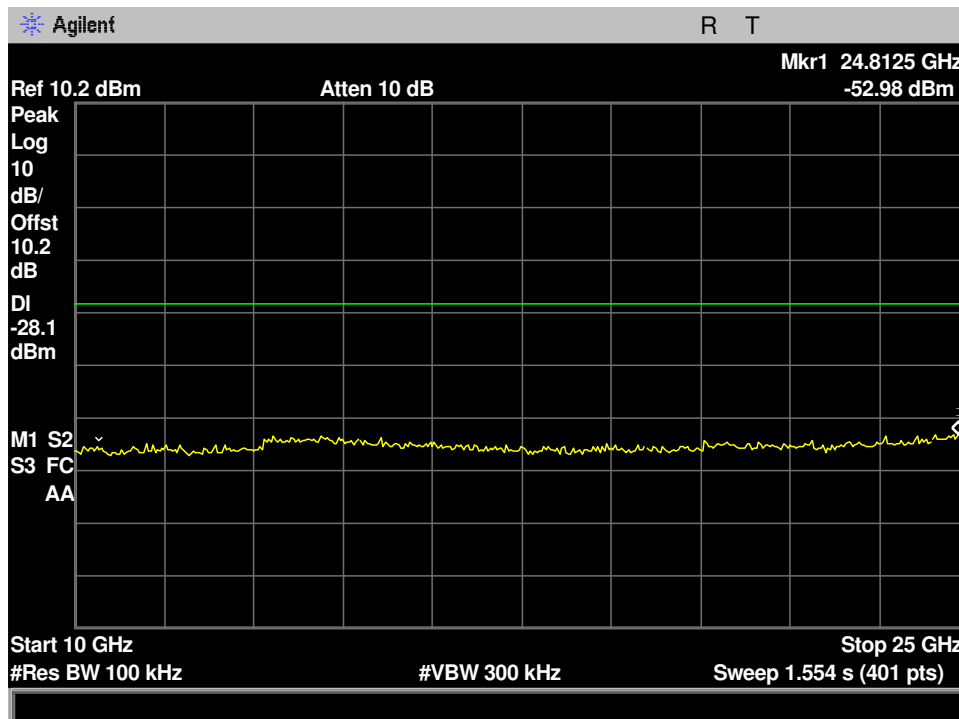

Conducted Spurious Emissions, 10GHz-25GHz, Low Channel, 2402MHz

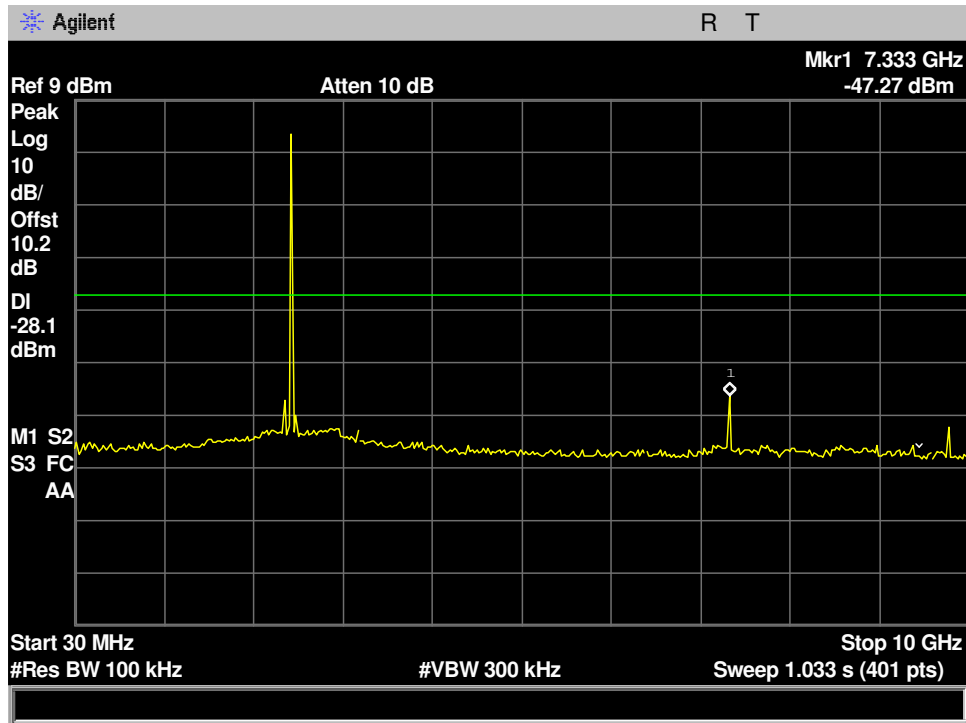

Conducted Spurious Emissions, 30MHz-10GHz, Mid Channel, 2442MHz

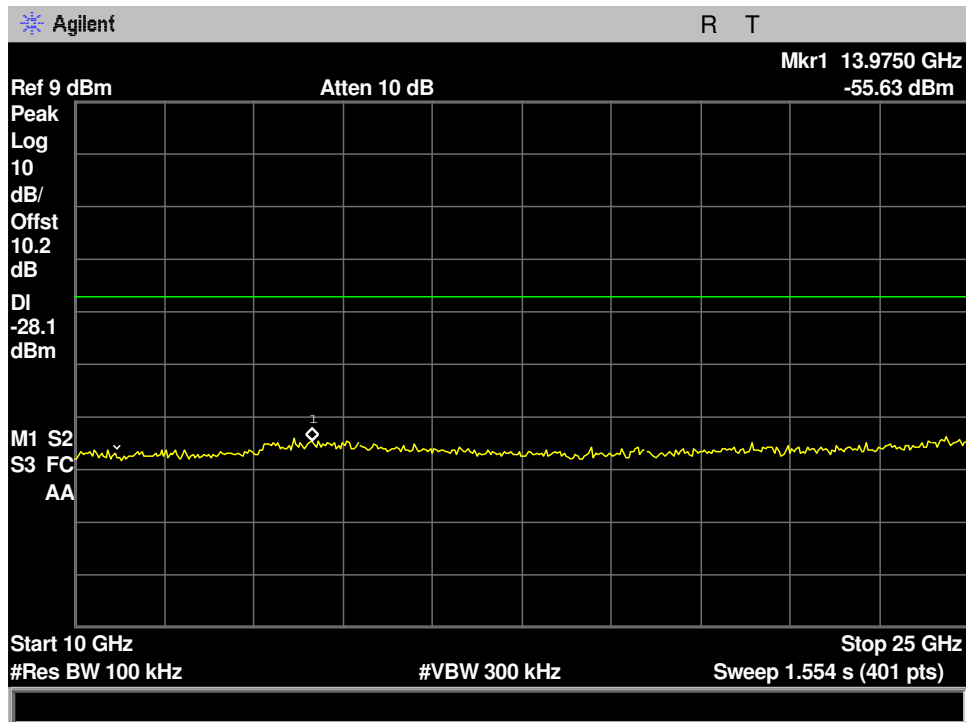

Conducted Spurious Emissions, 10GHz-25GHz, Mid Channel, 2442MHz

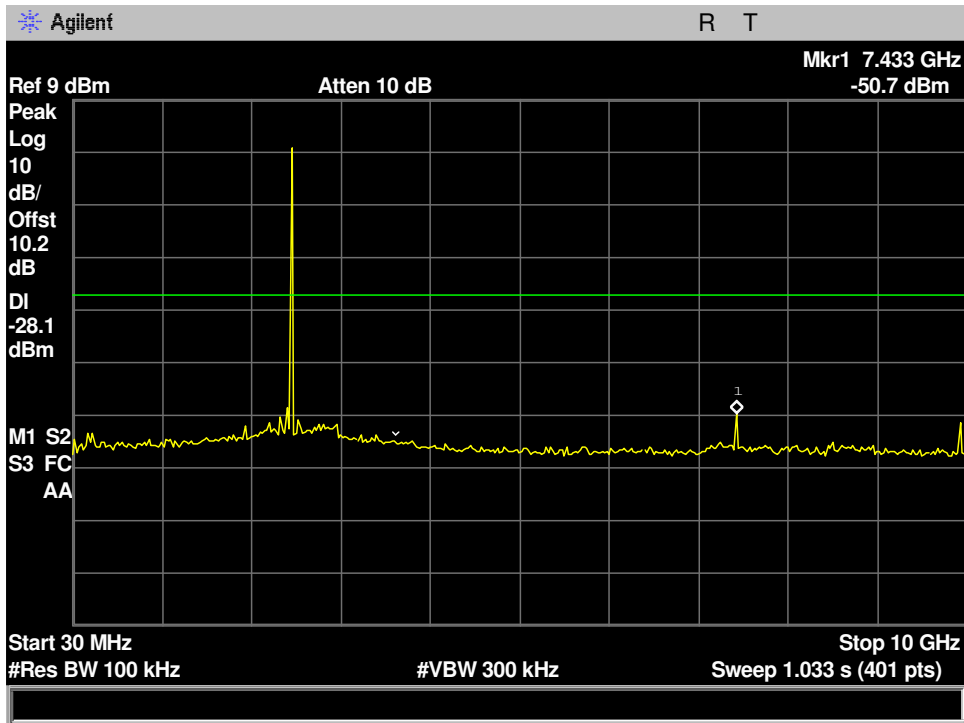

Conducted Spurious Emissions, 30MHz-10GHz, High Channel, 2480MHz

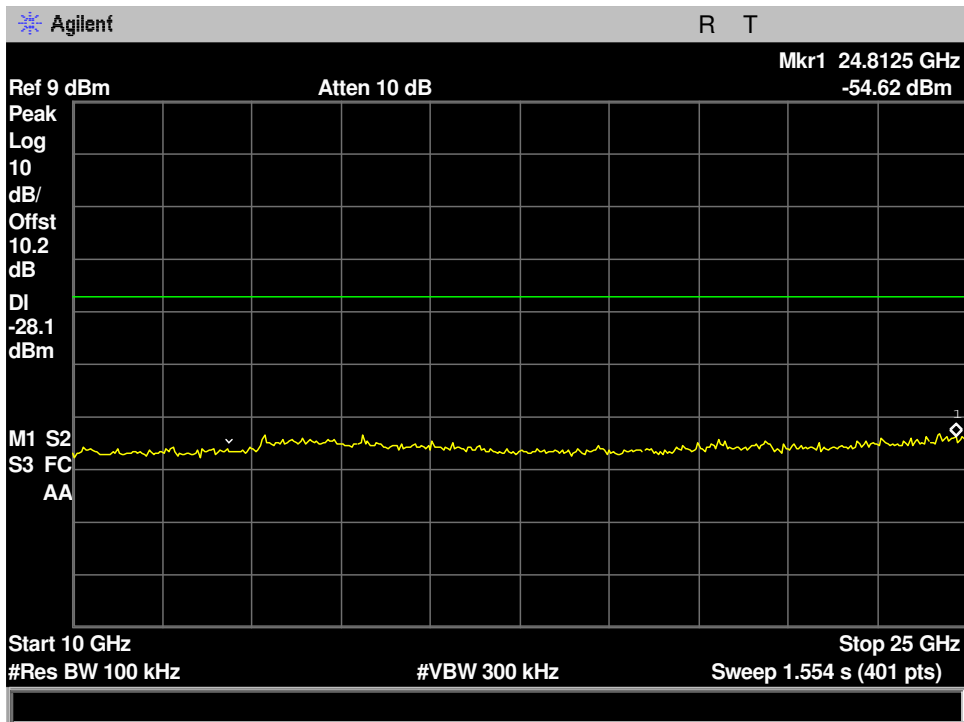

Conducted Spurious Emissions, 10GHz-25GHz, High Channel, 2480MHz

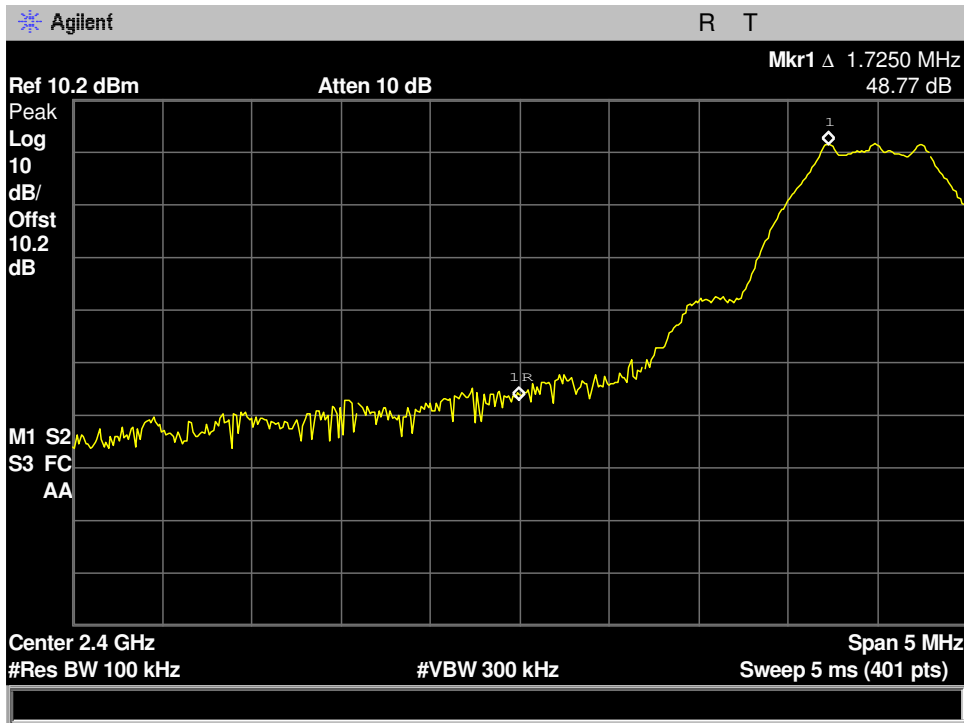

Conducted BandEdge, Low Channel, 2402MHz

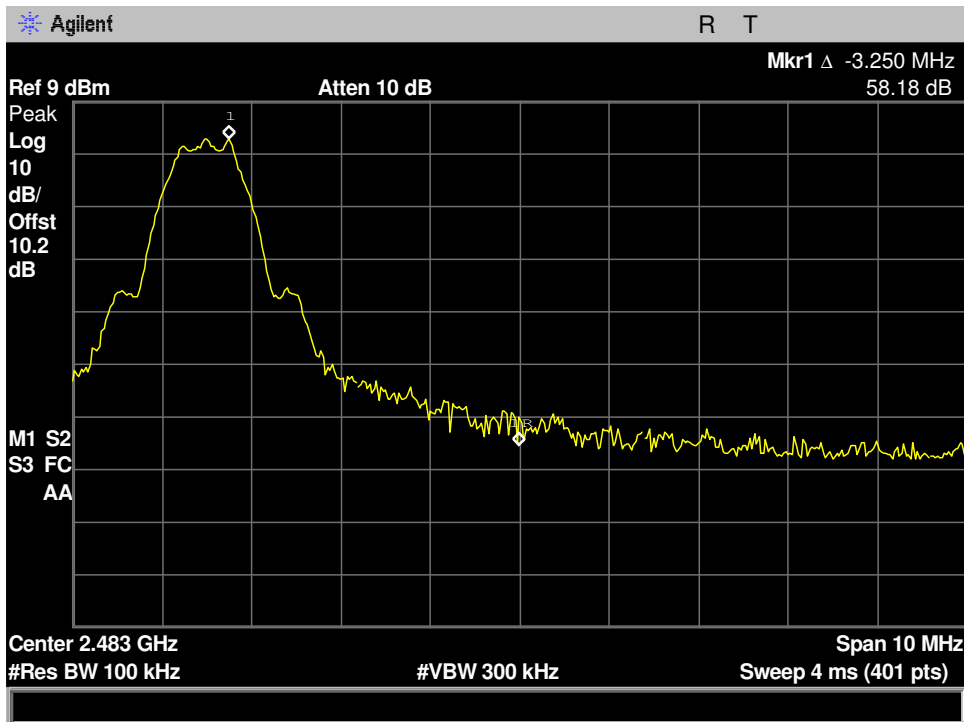

Conducted BandEdge, High Channel, 2480MHz

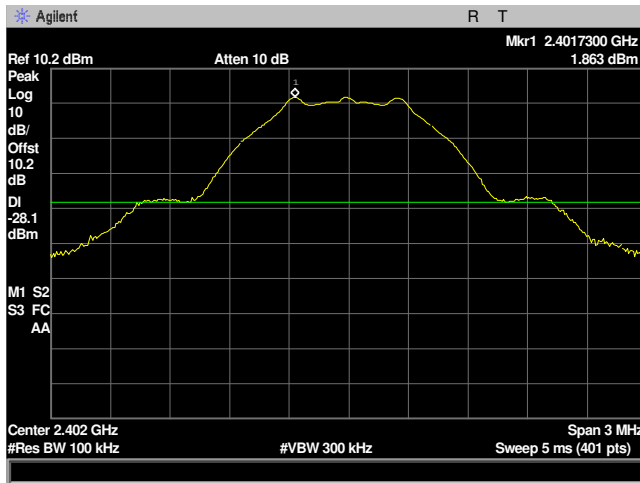

Reference, Low Channel, 2402MHz

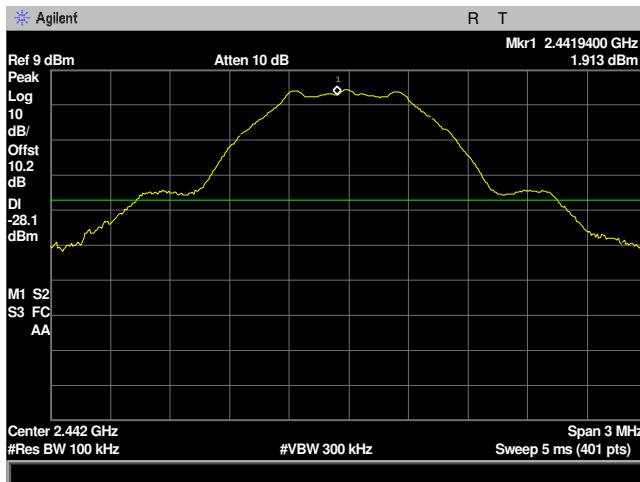

Reference, Mid Channel, 2442MHz

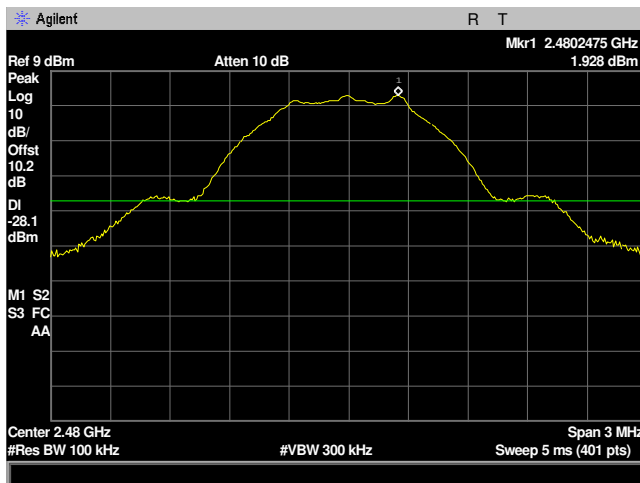

Reference, High Channel, 2480MHz



## Electromagnetic Compatibility Criteria for Intentional Radiators

### § 15.247(e) Power Spectral Density

**Test Requirements:** §15.247(e): For digitally modulated systems, the peak power spectral density conducted from the intentional radiator to the antenna shall not be greater than 8dBm in any 3 kHz band during any time interval of continuous transmission.

**Test Procedure:** The EUT was connected to a spectrum analyzer through a cable and an attenuator. Measurements were taken with the EUT set to transmit continuously on its low, mid, and high channels for all its bandwidths at maximum power. Power spectral density was measured according to measurement method AVGPSD-2, as described in ANSI C63.10-2013, section 11.10.5. Attenuator, cable loss, and duty factor were programmed into the spectrum analyzer.

**Test Results:** The EUT was Compliant with the peak power spectral density limits of § 15.247 (e).

The peak power spectral density was determined from plots on the following page(s).

**Test Engineer:** Arsalan Hasan

**Test Date:** 08/10/2021

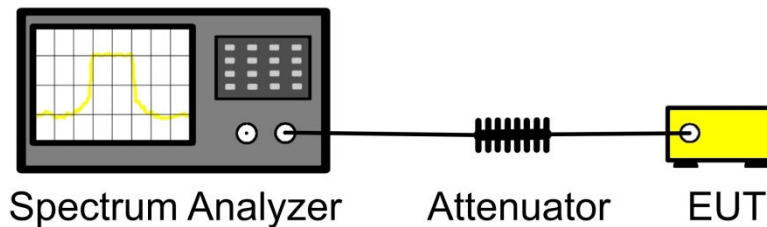

**Block Diagram, Power Spectral Density Test Setup**

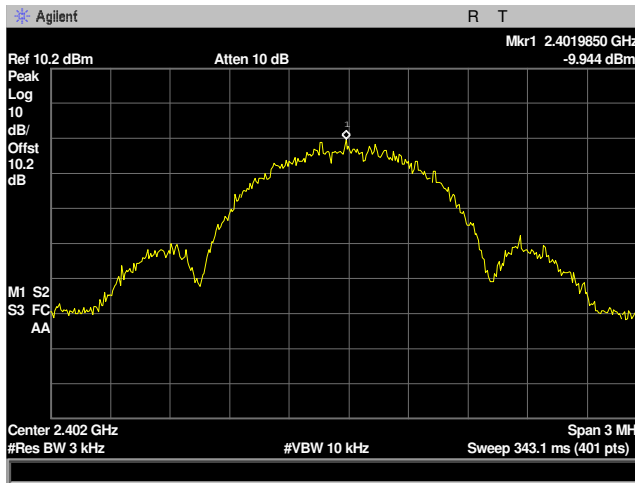

Power Spectral Density, Low Channel, 2402MHz

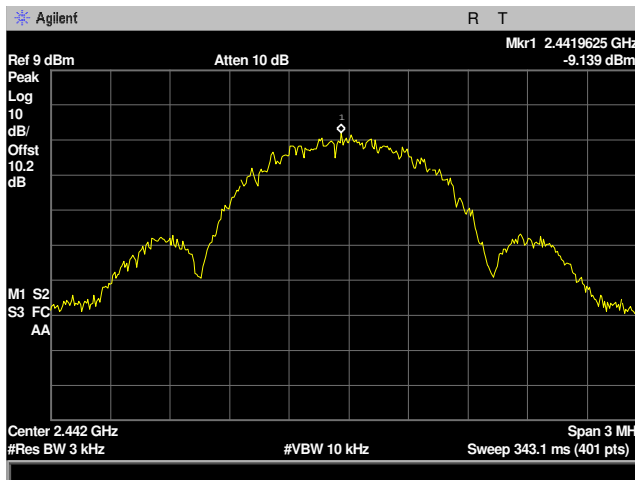

Power Spectral Density, Mid Channel, 2442MHz

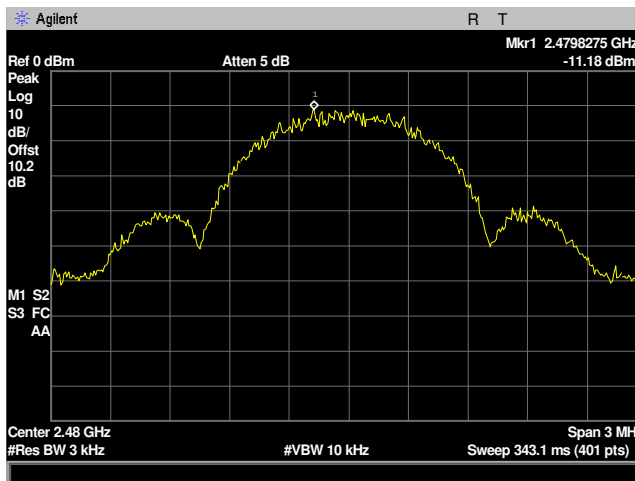

Power Spectral Density, High Channel, 2480MHz

## IV. Test Equipment

## Test Equipment

Calibrated test equipment utilized during testing was maintained in a current state of calibration per the requirements of ISO/IEC 17025:2017.

MET Asset #	Equipment	Manufacturer	Model	Last Cal Date	Cal Due Date
1S2399	TURNTABLE/MAST CONTROLLER	SUNOL SCIENCES	SC99V	SEE NOTE 1	SEE NOTE 1
1S2600	BILOG ANTENNA	TESEQ	CBL6112D	03/19/2021	03/19/2022
1S3826	DRG HORN ANTENNA	ETS-LINDGREN	3117	12/03/2020	12/03/2022
1S2003	PXA Signal Analyzer	Keysight	N9030B	09/15/2020	09/15/2021
1S2587	PRE AMPLIFIER	AML COMMUNICATIONS	AML0126L3801	SEE NOTE 1	SEE NOTE 1
1S2653	AMPLIFIER	SONOMA INSTRUMENT	310 N	SEE NOTE 1	SEE NOTE 1
1S2486	5 METER CHAMBER	PANASHIELD - ETS	5M	SEE NOTE 2	SEE NOTE 2
Note 1: Functionally tested equipment is verified using calibrated instrumentation at the time of testing. Note 2: Latest NSA and VSWR data available upon request.					

## Test Equipment List

**End of Report**