

# Test Report

- DFS tests only -

Report Number: F151596E12

Applicant:

**u-blox Malmö AB**

Manufacturer:

**u-blox Malmö AB**

Equipment under Test (EUT):

**ODIN-W260**



Deutsche  
Akkreditierungsstelle  
D-PL-17186-01-01  
D-PL-17186-01-02  
D-PL-17186-01-03

## REFERENCES

- [1] **FCC CFR 47 Part 15** Radio Frequency Devices
- [2] **KDB 905462 D02 UNII DFS Compliance Procedures New Rules v01r02 (May 2015)**  
Compliance measurement procedures for Unlicensed - National Information Infrastructure (U-NII) Devices operating in the 5250-5350 MHz and 5470-5725 MHz bands incorporating Dynamic Frequency Selection.
- [3] **KDB 905462 D03 Client without DFS New Rules v01r01 (August 2014)**  
Client Devices without radar detection capability.
- [4] **RSS-210 Issue 8 (December 2010)** Licence-exempt Radio Apparatus (All Frequency Bands): Category I Equipment
- [5] **RSS-Gen Issue 4 (November 2014)** General Requirements and Information for the Certification of Radiocommunication Equipment

## TEST RESULT

The requirements of the tests performed as shown in the overview (clause 4) were fulfilled by the equipment under test.

The complete test results are presented in the following.

Test engineer:	Manuel BASTERT		24 September 2015
	Name	Signature	Date
Authorized reviewer:	Bernd STEINER		24 September 2015
	Name	Signature	Date

## RESERVATION

This test report is only valid in its original form.

Any reproduction of its contents in extracts without written permission of the accredited test laboratory PHOENIX TESTLAB GmbH is prohibited.

The test results herein refer only to the tested sample. PHOENIX TESTLAB GmbH is not responsible for any generalisations or conclusions drawn from these test results concerning further samples. Any modification of the tested samples is prohibited and leads to the invalidity of this test report. Each page necessarily contains the PHOENIX TESTLAB Logo and the TEST REPORT NUMBER.

## Contents:

1 Identification .....	4
1.1 Applicant .....	4
1.2 Manufacturer .....	4
1.3 Test laboratory .....	4
1.4 EUT (Equipment Under Test).....	5
1.5 Technical data of equipment.....	5
1.6 Ancillary equipment .....	8
1.7 Dates.....	8
2 Operational states.....	9
3 Additional information.....	9
4 Test overview and DFS parameters .....	10
4.1 Test frequencies.....	10
4.2 Applicability of DFS requirements Prior to Use of a Channel .....	10
4.3 Applicability of DFS requirements during normal operation.....	10
4.4 DFS detection thresholds for master devices and client devices with radar detection .....	10
4.5 DFS response requirement values.....	11
4.6 Radar test waveforms.....	12
4.7 Channel loading .....	13
5 Test results .....	14
5.1 Channel Shutdown and Non-Occupancy period.....	14
6 Test equipment.....	19
7 Report history .....	19
8 List of Annexes .....	20

## 1 Identification

### 1.1 Applicant

Name:	u-blox Malmö AB
Address:	Östra Varvsgatan 4, 5 tr, 211 75 Malmö
Country:	Sweden
Name for contact purposes:	Mr. Mats Andersson
Phone:	+ 46 40 63 07 100
Fax:	+ 46 40 23 71 37
Mail address:	mats.andersson@u-blox.com

### 1.2 Manufacturer

Name:	u-blox Malmö AB
Address:	Östra Varvsgatan 4, 5 tr, 211 75 Malmö
Country:	Sweden
Name for contact purposes:	Mr. Mats Andersson
Phone:	+ 46 40 63 07 100
Fax:	+ 46 40 23 71 37
Mail address:	mats.andersson@u-blox.com

### 1.3 Test laboratory

The tests were carried out by: **PHOENIX TESTLAB GmbH**  
**Königswinkel 10**  
**32825 Blomberg**  
**Germany**

accredited by Deutsche Akkreditierungsstelle GmbH (DAKKS) in compliance with DIN EN ISO/IEC 17025 under the Reg. No. D-PL-17186-01-02, FCC Test site registration number 90877 and Industry Canada Test site registration IC3469A-1.

## 1.4 EUT (Equipment Under Test)

Test object: *	WLAN / Bluetooth module
Model / PMN: *	ODIN-W2
FCC ID: *	PVH0965
IC Company number / UPN: *	5325A-0965
HVIN	ODIN-W260 ODIN-W262
Serial number: *	#21
PCB identifier: *	0965-02
Hardware version: *	2.1
Software version / FVIN: *	0.11

\* declared by the applicant

## 1.5 Technical data of equipment

Fulfills WLAN specification: *	IEEE, 802.11b, 802.11g, 802.11n (HT20), 802.11a
Antenna type: *	See Table 1
Antenna gain: *	See Table 1
Antenna connector: *	See Table 1
Power supply EUT	3.0 – 3.6 V <sub>DC</sub>
Power supply carrier board	5.0 V <sub>DC</sub>
Type of modulation: *	802.11a: OFDM 802.11b: CCK, DQPSK, DBPSK 802.11g: OFDM 802.11n: OFDM
Operating frequency range:*	2412 MHz to 2462 MHz, 5180 MHz to 5240 MHz, 5260 MHz to 5320 MHz, 5500 MHz to 5700 MHz (except 5600 MHz to 5650 MHz) 5745 MHz to 5825 MHz
Temperature range: *	-40 °C to +85 °C
Lowest / highest Internal clock frequency: *	32.768 kHz / 26 MHz
Number of transmit chains *	One
Number of receive chains *	One
Nominal channel bandwidth*	20 MHz only
DFS Operation mode *	Client without radar detection

\* declared by the applicant.

Table 1 Antenna specifications

Antenna name	Manufacturer	Type	Comment	Gain [dBi]
WCR-2400 -IP04 -IP10 -SMA -SMRP	Centurion	Monopole	10cm flying lead U.FL 25cm flying lead U.FL RSMA	2 dBi @ 2.4 GHz
SDM2-2400/1575	Mobile Mark	Patch	flying lead U.FL	2 dBi @ 2.4 GHz
PSTG0-2400HS -RSMA	Mobile Mark	Monopole	RSMA	0 dBi @ 2.4 GHz
FlatWhip-2400	ProAnt	Monopole	RSMA	3 dBi @ 2.4 GHz
InSide-2400	ProAnt	Patch	10cm flying lead U.FL	3 dBi @ 2.4 GHz
InSide-WLAN	ProAnt	Patch	dual band 10cm flying lead U.FL	3 dBi @ 2.4 GHz 3 dBi @ 5 GHz
Outside-2400	ProAnt	Patch	7 cm flying lead U.FL 10 cm flying lead U.FL 25 cm flying lead U.FL	3 dBi @ 2.4 GHz
Ex-IT 2400 -RP-SMA 28-001 -MHF 28-001	ProAnt	Monopole	RSMA 10 cm flying lead U.FL	3 dBi @ 2.4 GHz
Ex-IT WLAN - RP-SMA -MHF	ProAnt	Monopole	dual band RSMA 10cm flying lead U.FL	3 dBi @ 2.4 GHz 3 dBi @ 5 GHz
Ex-IT 2400 -MHF 70-001	ProAnt	Monopole	10cm flying lead U.FL	3 dBi @ 2.4 GHz
Ex-IT 2400 -RP-SMA 70-002	ProAnt	Monopole	RSMA	3 dBi @ 2.4 GHz
InSide Fold-2400	ProAnt	Patch	10 cm flying lead U.FL	3 dBi @ 2.4 GHz
InSide Fold-WLAN	ProAnt	Patch	dual band 10 cm flying lead U.FL	2.5 dBi @ 2.4 GHz 3 dBi @ 5 GHz
InSide-WLAN Square	ProAnt	Patch	Dual band; 10 cm flying lead U.FL	3 dBi @ 2.4 GHz 3 dBi @ 5 GHz
OnBoard SMD 2400	ProAnt	Patch	SMD PIFA antenna on ODIN-W162	3 dBi @ 2.4 GHz <3 dBi @ 5 GHz
R380.500.125 R380.500.124 R380.500.139	Pulse	Monopole	.125: RSMA .124: RSMA+SEAL .139: RSMA+SEAL	2 dBi @ 2.4 GHz
SOA 2400/360/3/20/V	Huber+Suhner	Monopole	150 cm cable / RSMA (P/N 1324.99.033) 150 cm cable/MCX (P/N 1324.99.0036)	3 dBi @ 2.4 GHz
NanoBlue-IP04	Laird Technologies	Patch	10 cm cable/U.FL	2 dBi @ 2.4 GHz

### 5.15 - 5.25 GHz band (Non-DFS-band)

Channel 36	RX:	5180 MHz	TX:	5180 MHz
Channel 40	RX:	5200 MHz	TX:	5200 MHz
Channel 44	RX:	5220 MHz	TX:	5220 MHz
Channel 48	RX:	5240 MHz	TX:	5240 MHz

### 5.25 - 5.35 GHz band

Channel 52	RX:	5260 MHz	TX:	5260 MHz
Channel 56	RX:	5280 MHz	TX:	5280 MHz
Channel 60	RX:	5300 MHz	TX:	5300 MHz
Channel 64	RX:	5320 MHz	TX:	5320 MHz

### 5.47 - 5.725 GHz band

Channel 100	RX:	5500 MHz	TX:	5500 MHz
Channel 104	RX:	5520 MHz	TX:	5520 MHz
Channel 108	RX:	5540 MHz	TX:	5540 MHz
Channel 112	RX:	5560 MHz	TX:	5560 MHz
Channel 116	RX:	5580 MHz	TX:	5580 MHz
Channel 120	RX:	5600 MHz	TX:	5600 MHz
Channel 124	RX:	5620 MHz	TX:	5620 MHz
Channel 128	RX:	5640 MHz	TX:	5640 MHz
Channel 132	RX:	5660 MHz	TX:	5660 MHz
Channel 136	RX:	5680 MHz	TX:	5680 MHz
Channel 140	RX:	5700 MHz	TX:	5700 MHz

The grey-marked channels are not supported by the EUT.

### 5.745 - 5.825 GHz band

Channel 149	RX:	5745 MHz	TX:	5745 MHz
Channel 153	RX:	5765 MHz	TX:	5765 MHz
Channel 157	RX:	5785 MHz	TX:	5785 MHz
Channel 161	RX:	5805 MHz	TX:	5805 MHz
Channel 165	RX:	5825 MHz	TX:	5825 MHz

## 1.6 Ancillary equipment

- DFS Master Cisco AIR-SAP1602E-A-K9 (Serial-No.: FGL1739X1LS)  
FCC ID: LDK102084 / IC number: 2461B-102084
- Test laptop Acer Aspire one ZG8 (Serial-No.: LUS750B02191210D892500)
- Test laptop Lenovo ThinkPad 20AV-0031MS (Serial-No.: R9-0027RV 13/11)
- USB carrier board EVB-W26

## 1.7 Dates

Date of receipt of test sample:	09 September 2015
Start of test:	14 September 2015
Finish of test:	16 September 2015



## 2 Operational states

The EUT is an industrial Wireless LAN slave device without own radar detection mechanism working in the 5 GHz U-NII band. The measurements were carried out according to setup shown in the drawing below. The traffic was generated using a packet generator software running on the Acer test laptop from the master to the client device. A Cisco Access Point AIR-SAP1602E-A-9 was used as DFS master. The attenuation of the test system was adjusted to reach the DFS detection threshold of -62 dBm at the antenna ports of the master. The test setup is shown in the following picture.

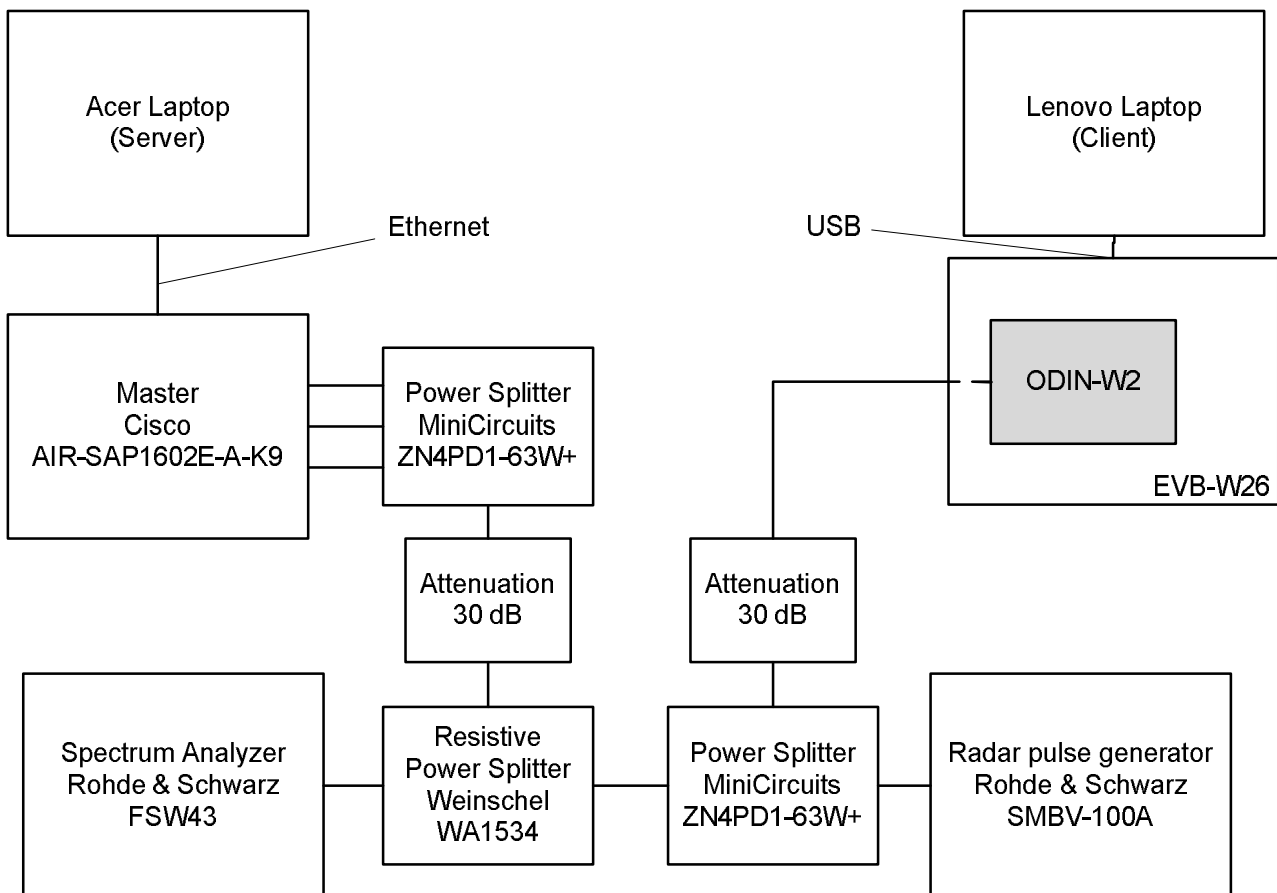

The second rf-port is for MIMO operation in WLAN 2.4 GHz only and disabled at 5 GHz. Therefore only the main rf-connector was used for these tests.

## 3 Additional information

The EUT is available in two variants, one with U.FL antenna connectors (ODIN-W260) and one with integral antenna (ODIN-W262). Only the variant ODIN-W260 with antenna connector was tested. Regarding DFS there is no difference between both variants.

## 4 Test overview and DFS parameters

Application	Frequency range [MHz]	FCC 47 CFR Part 15 section [1]	RSS 210, Issue 8 [3]	Status	Refer page
Dynamic Frequency Selection (DFS)	5250 – 5350 5470 – 5725	15.407 (h) (2)	A9.3 [4]	Passed	14 et seq

### 4.1 Test frequencies

One frequency will be chosen from the operating channels of the EUT within the 5250-5350 MHz or 5470-5725 MHz bands.

### 4.2 Applicability of DFS requirements Prior to Use of a Channel

Requirement	DFS Operational mode		
	Master	Client (without DFS)	Client (with DFS)
Non-Occupancy Period	✓	Not required*	✓
DFS Detection Threshold	✓	Not required	✓
Channel Availability Check Time	✓	Not required	Not required
Uniform Spreading	✓	Not required	Not required
U-NII Detection Bandwidth	✓	Not required	✓

\* An analyser plot containing a single 30-minute sweep on the original channel is stipulated by [3].

### 4.3 Applicability of DFS requirements during normal operation

Requirement	DFS Operational mode		
	Master	Client (without DFS)	Client (with DFS)
DFS Detection Threshold	✓	Not required	✓
Channel Closing Transmission Time	✓	✓	✓
Channel Move Time	✓	✓	✓
U-NII Detection Bandwidth	✓	Not required	✓

### 4.4 DFS detection thresholds for master devices and client devices with radar detection

Maximum transmit power	Value (see Notes 1 and 2)
≥ 200 mW (23 dBm)	-64 dBm
< 200 mW (23 dBm)	-62 dBm

Note 1: This is the level at the input of the receiver assuming a 0 dBi receive antenna.  
 Note 2: Throughout these test procedures an additional 1 dB has been added to the amplitude of the test transmission waveforms to account for variations in measurement equipment. This will ensure that the test signal is at or above the detection threshold level to trigger a DFS response.

#### 4.5 DFS response requirement values

Parameter	Value
Non-Occupancy Period	Minimum 30 minutes
Channel Availability Check Time	60 s
Channel Move Time	10 s See Note 1
Channel Closing Transmission Time	200 ms + an aggregate of 60 ms over remaining 10 s period See Notes 1 and 2
<p><b>Note 1:</b> The instant that the <i>Channel Move Time</i> and the <i>Channel Closing Transmission Time</i> begins is as follows:</p> <ul style="list-style-type: none"> <li>• For the Short Pulse Radar Test Signals this instant is the end of the <i>Burst</i>.</li> <li>• For the Frequency Hopping radar Test Signal, this instant is the end of the last radar <i>Burst</i> generated.</li> <li>• For the Long Pulse Radar Test Signal this instant is the end of the 12 second period defining the <i>Radar Waveform</i>.</li> </ul> <p><b>Note 2:</b> The <i>Channel Closing Transmission Time</i> is comprised of 200 milliseconds starting at the beginning of the <i>Channel Move Time</i> plus any additional intermittent control signals required to facilitate a <i>Channel</i> move (an aggregate of 60 milliseconds) during the remainder of the 10 second period. The aggregate duration of control signals will not count quiet periods in between transmissions.</p>	

## 4.6 Radar test waveforms

Short pulse radar test waveform used for the tests:

Radar type	Pulse width [μs]	Pulse repetition interval [μs]	Number of pulses
0	1	1428	18

Radar test signal 0 at 5.5 GHz (detection threshold calibration plot)

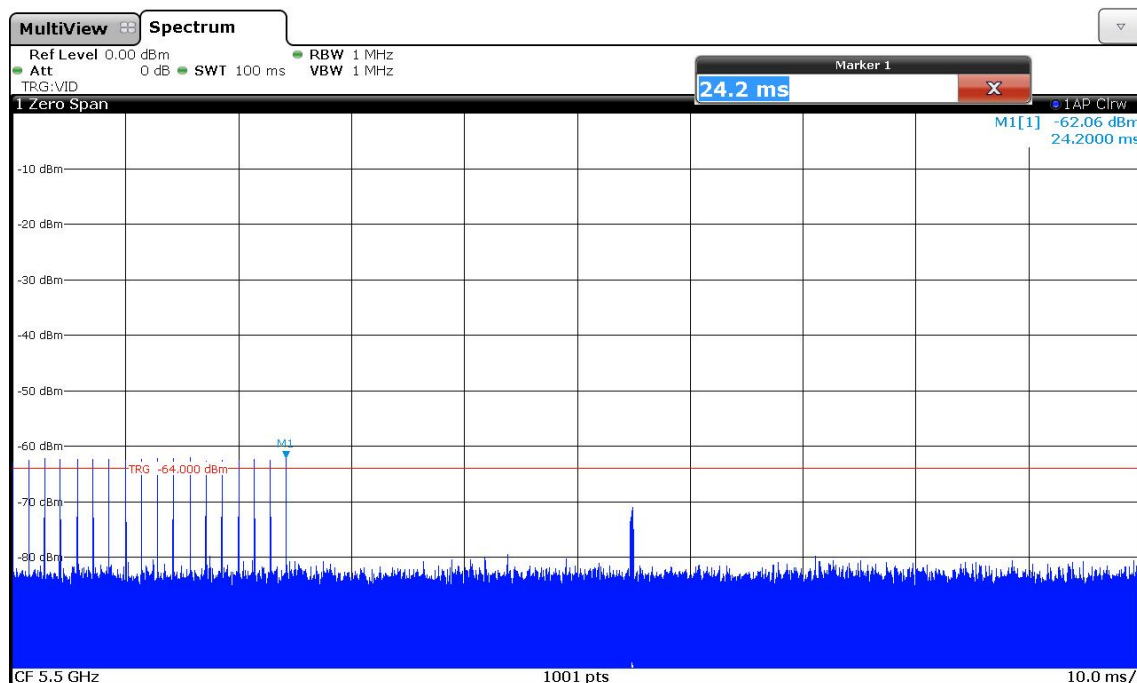

## 4.7 Channel loading

System testing will be performed with channel-loading using means appropriate to the data types that are used by the unlicensed device. The following requirements apply:

- The data file must be of a type that is typical for the device (i.e., MPEG-2, MPEG-4, WAV, MP3, MP4, AVI, etc.) and must generally be transmitting in a streaming mode.
- Software to ping the client is permitted to simulate data transfer but must have random ping intervals.
- Timing plots are required with calculations demonstrating a minimum channel loading of approximately 17% or greater. For example, channel loading can be estimated by setting the spectrum analyzer for zero span and approximate the Time On / (Time On + Off Time). This can be done with any appropriate channel BW and modulation type.
- Unicast or Multicast protocols are preferable but other protocols may be used. The appropriate protocol used must be described in the test procedures.

Channel load at 5.5 GHz:

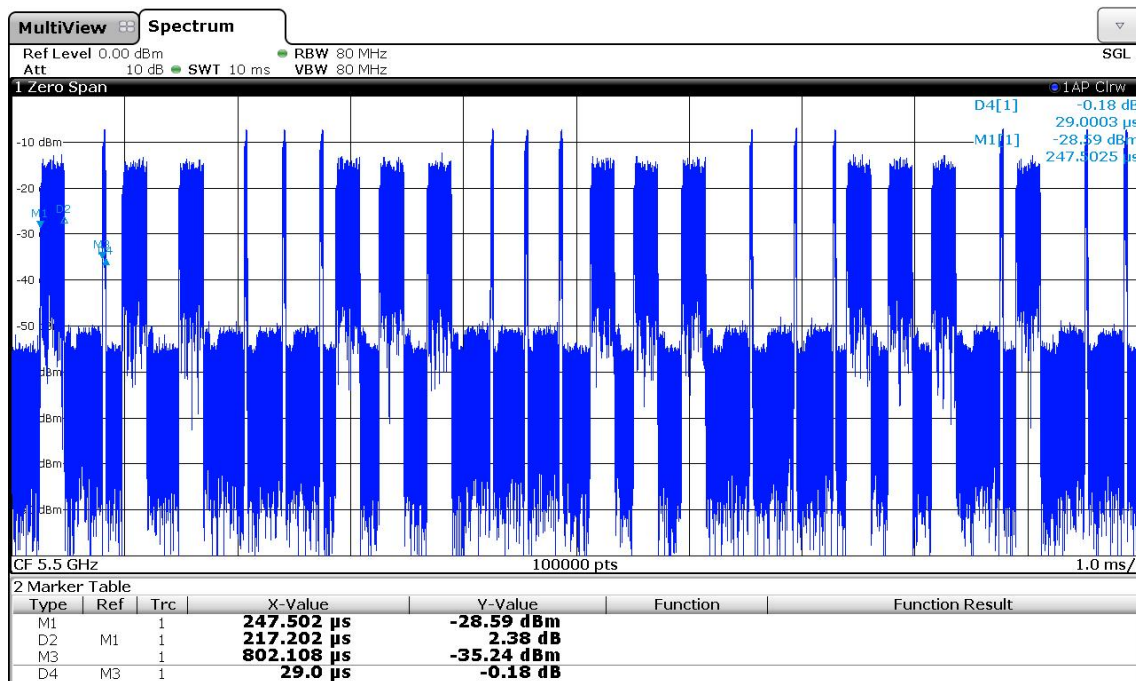

$$\text{Channel load} = \frac{\text{Time on}}{(\text{Time on} + \text{Off Time})} = \frac{(217.202 \mu\text{s} \times 13 \text{ pulses}) + (29.0 \mu\text{s} \times 13 \text{ pulses})}{10 \text{ ms}} = 0.32 \xrightarrow{\text{yields}} 32 \%$$

## 5 Test results

### 5.1 Channel Shutdown and Non-Occupancy period

The measurement procedure and limits are described in clause 7.8.3 [2].

Operation mode: EUT is in continuous transmission mode with specified test transmission load generated by specific load data (minimum 17 % channel load) from the master to the slave. After the radar event the master initiates the *Channel Shutdown* process given in the table below:

Channel Shutdown	Channel Closing Transmission Time	200 ms + 60 ms*
	Channel Move Time	10 s
Non-Occupancy period		30 min

\* see chapter 4.3, note 2

The following table and measurement plots show the results of the *Channel Shutdown*.

Measurement results Channel Shutdown		
Master and slave connected, data traffic active / Radar detection threshold level: -62 dBm		
Radar pulse	Radar type 0	
Operating frequency	5 280 MHz	5 540 MHz
Channel bandwidth	20 MHz	20 MHz
Channel closing time	< 200 ms	< 200 ms
Channel move time	< 10 s	< 10 s

Measurement results Non-Occupancy period		
Master and slave connected, data traffic active / Radar detection threshold level: -62 dBm		
Radar pulse	Radar type 0	
Operating frequency	5 280 MHz	5 540 MHz
Non occupancy period	> 30 min	> 30 min
Measurement uncertainty: < 10 %		

### ODIN-W2 operating in 5250-5350 MHz band

Channel closing transmission time at 5280 MHz

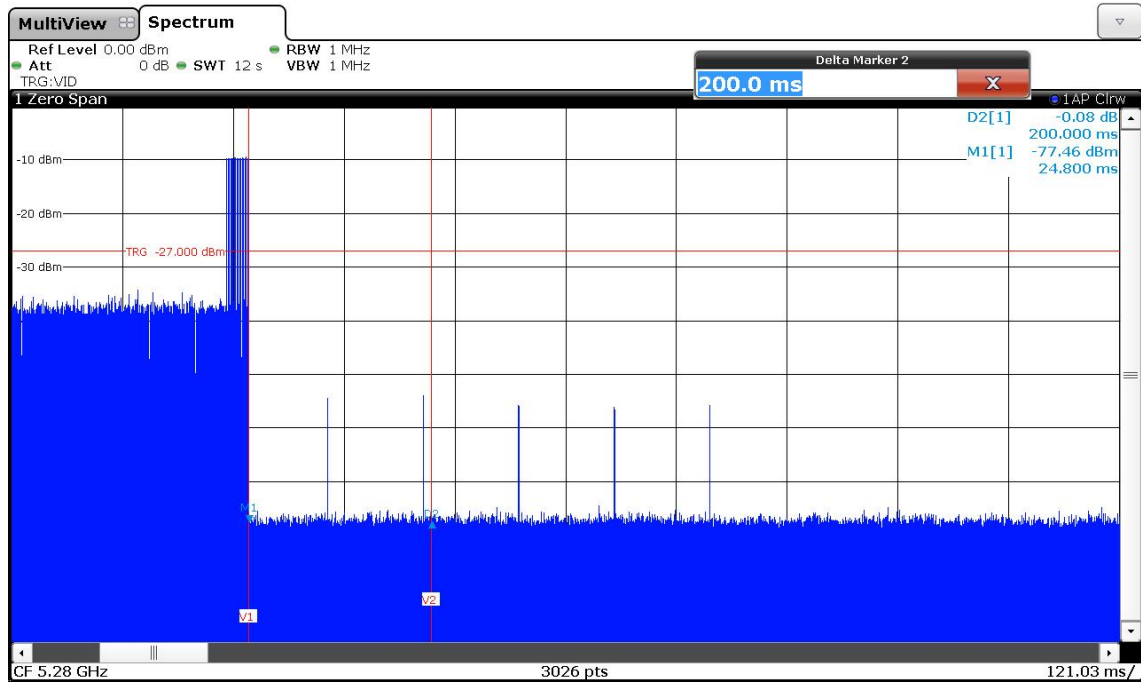

The beacons after the channel closing transmission time of 200 ms are additional intermittent control signals caused by the master (See Note 2 in 4.5).

Channel move time at 5280 MHz

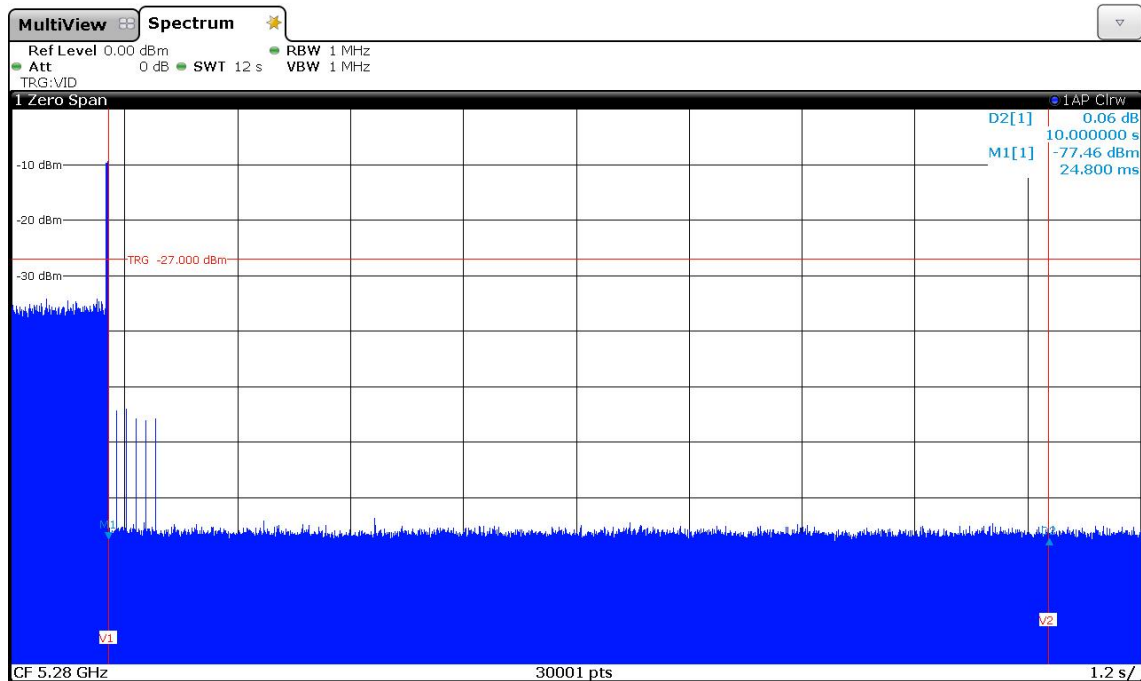

**ODIN-W2 operating in 5250-5350 MHz band**

Non occupancy period at 5320 MHz type 0 radar event

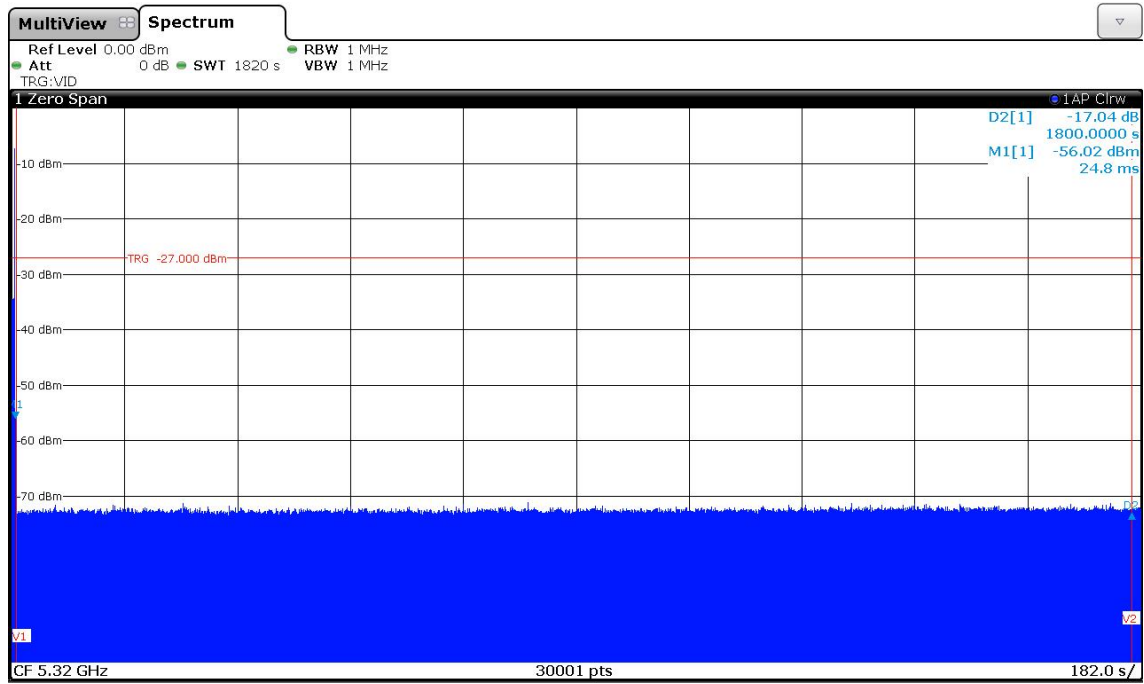



### ODIN-W2 operating in 5470-5725 MHz band

Channel closing transmission time at 5540 MHz

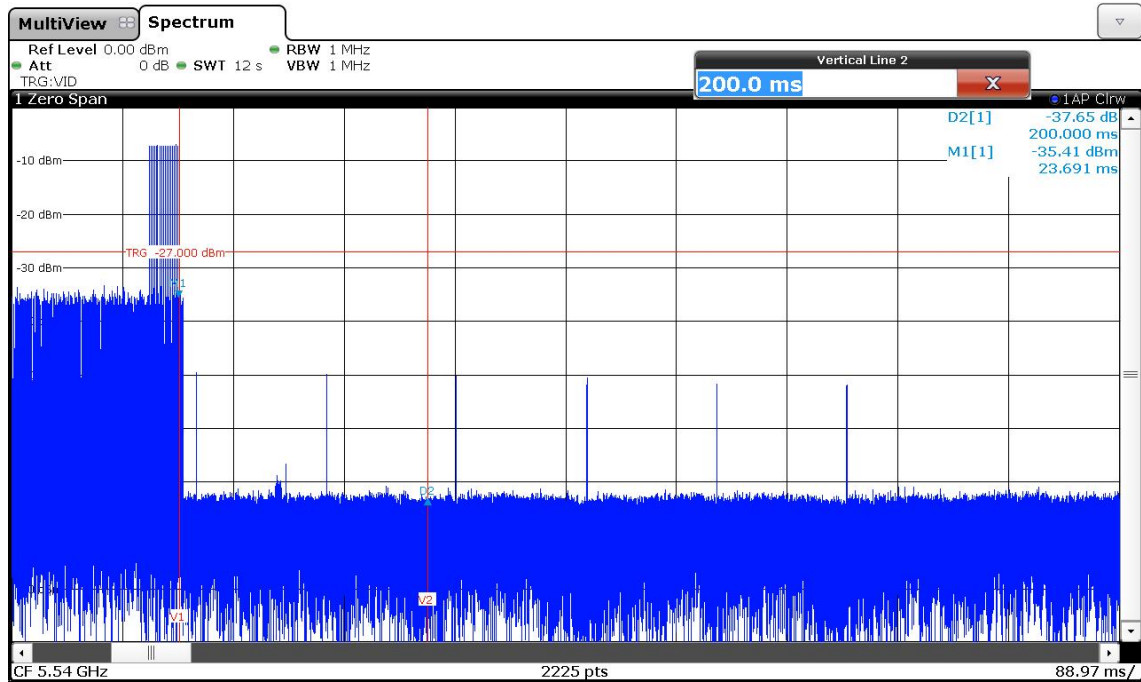

The beacons after the channel closing transmission time of 200 ms are additional intermittent control signals caused by the master (See Note 2 in 4.5).

Channel move time at 5540 MHz

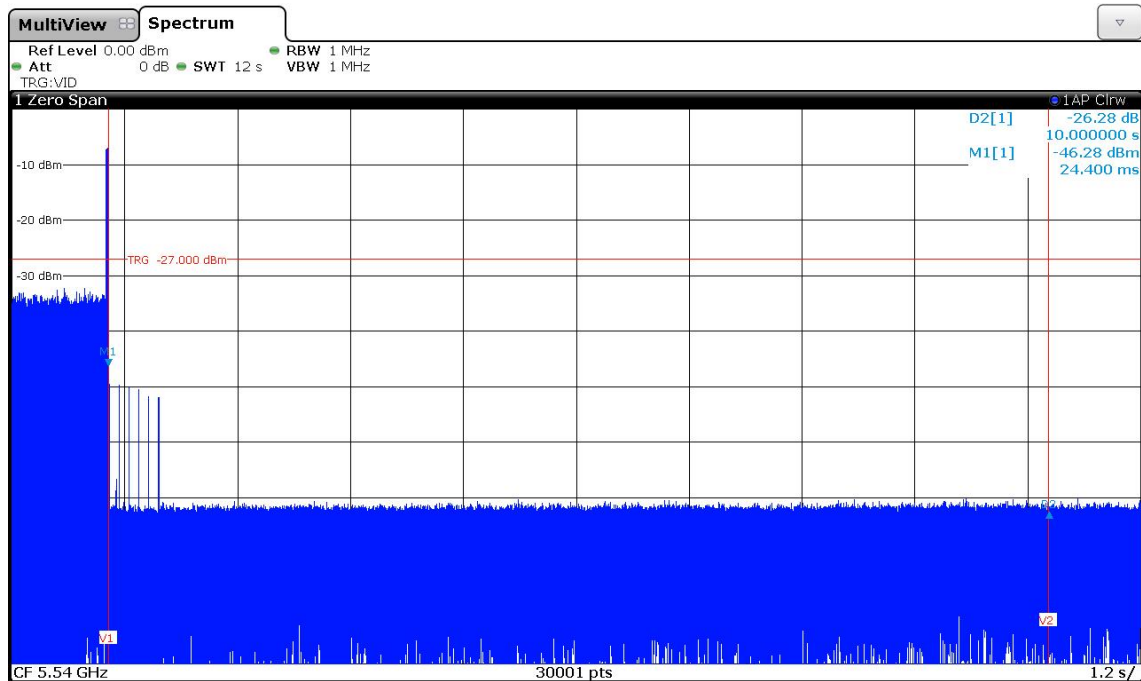

**ODIN-W2 operating in 5470-5725 MHz band**

Non occupancy period at 5660 MHz type 0 radar event

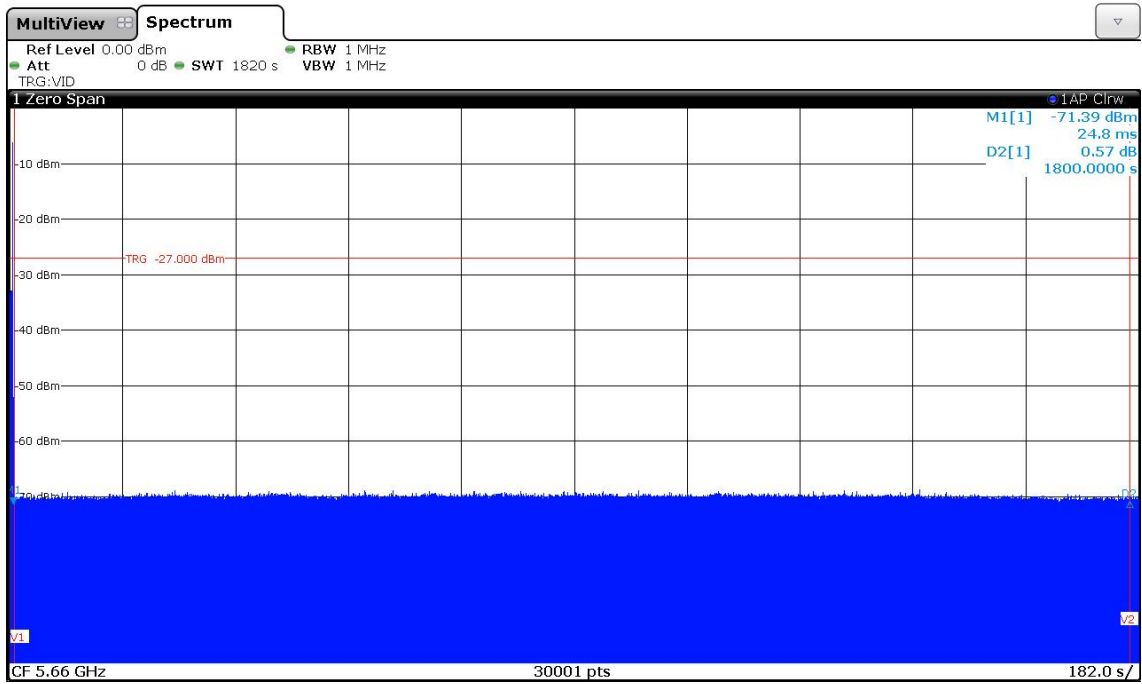

## 6 Test equipment

No.	Test equipment	Type	Manufacturer	Serial No.	PM-No	Date of calibration	
01	Spectrum analyser	FSW43	Rohde & Schwarz	100586	481720	02/27/2014	02/2016
02	Vector signal generator	SMBV-100A	Rohde & Schwarz	255092	481326	03/10/2015	03/2016
03	Attenuator 11 dB	8494B	Hewlett-Packard	3308A38264	480264	Weekly verification	
04	Attenuator 110 dB	8496B	Agilent	00626	480265	Weekly verification	
05	4-way power divider	ZN4PD1-63W-S+	Mini Circuits	-	481787	Weekly verification	
06	4-way power divider	ZN4PD1-63W-S+	Mini Circuits	-	481788	Weekly verification	
07	2-way resistive divider	WA1534	Weinschel	A106	481453	Weekly verification	
08	Attenuator 10 dB	WA8/18-10-34	Weinschel	-	481448	Weekly verification	
09	Attenuator 20 dB	WA8/18-20-34	Weinschel	-	481451	Weekly verification	

## 7 Report history

Report Number	Date	Comment
F151496E12	24 September 2015	Document created

## 8 List of Annexes

ANNEX A	TEST SETUP PHOTOS		3 pages
	151496_DFS1.jpg	Test setup	
	151496_DFS2.jpg	Test setup	
	151496_DFS3.jpg	Test setup	
ANNEX B	EXTERNAL PHOTOS		3 pages
	151496_DFS4.jpg	ODIN-W260 mounted on carrier board, top view	
	151496_DFS5.jpg	Carrier board, bottom view	
	151496_DFS6.jpg	Type plate of used Cisco master device	
ANNEX C	INTERNAL PHOTOS		2 pages
	151496_03.jpg	ODIN-W260, top view, shielding removed	
	151496_04.jpg	ODIN-W260, bottom view	