

TR-4-E-009 Radiated Emission Test Result

Test Date: 2022-11-04 **Tested By:** James Gan
EUT: BLUETOOTH HEADSET **Model Number:** TOUR PRO 2
Test Mode: Tx mode **Power Supply:** Battery
Condition: Temp:22.2°C;Humi:56.7%;Press:100.3kPa **Test Site:** DDT 3# Chamber
File Path: d:\ts\2022 report data\Q22092806-2E TOUR PRO2\FCC ABOVE 1G\53
Memo: BLE 1M 2402

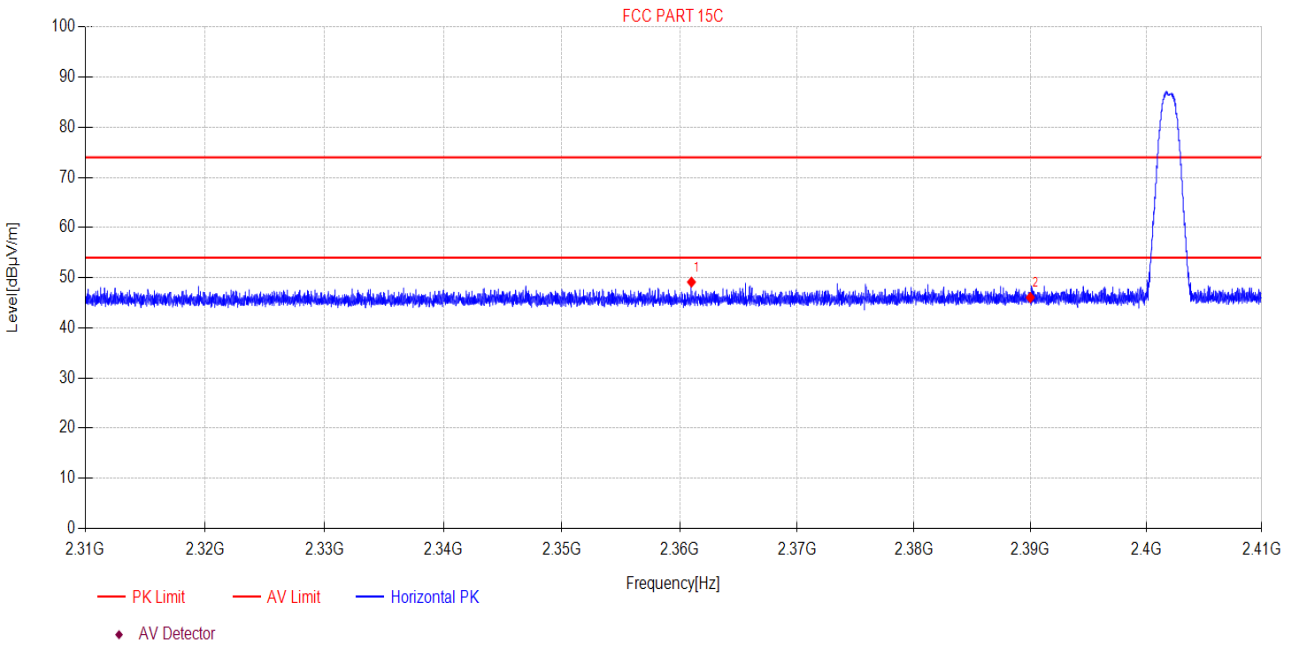

Suspected Data List								
NO.	Freq. [MHz]	Reading [dBµV]	Factor [dB]	Level [dBµV/m]	Limit [dBµV/m]	Margin [dB]	Detector	Polarity
1	2361.00	48.91	0.22	49.13	74.00	24.87	PK	Horizontal
2	2390.00	45.77	0.28	46.05	74.00	27.95	PK	Horizontal

- Note:
1. Level = Reading + Factor.
 2. If Peak Result complies with AV limit, AV Result is deemed to comply with AV limit.
 3. Test setup: RBW: 1 MHz, VBW: 3 MHz, Sweep time: auto.

TR-4-E-009 Radiated Emission Test Result

Test Date: 2022-11-04 **Tested By:** James Gan
EUT: BLUETOOTH HEADSET **Model Number:** TOUR PRO 2
Test Mode: Tx mode **Power Supply:** Battery
Condition: Temp:22.2°C;Humi:56.7%;Press:100.3kPa **Test Site:** DDT 3# Chamber
File Path: d:\ts\2022 report data\Q22092806-2E TOUR PRO2\FCC ABOVE 1G\54
Memo: BLE 1M 2402

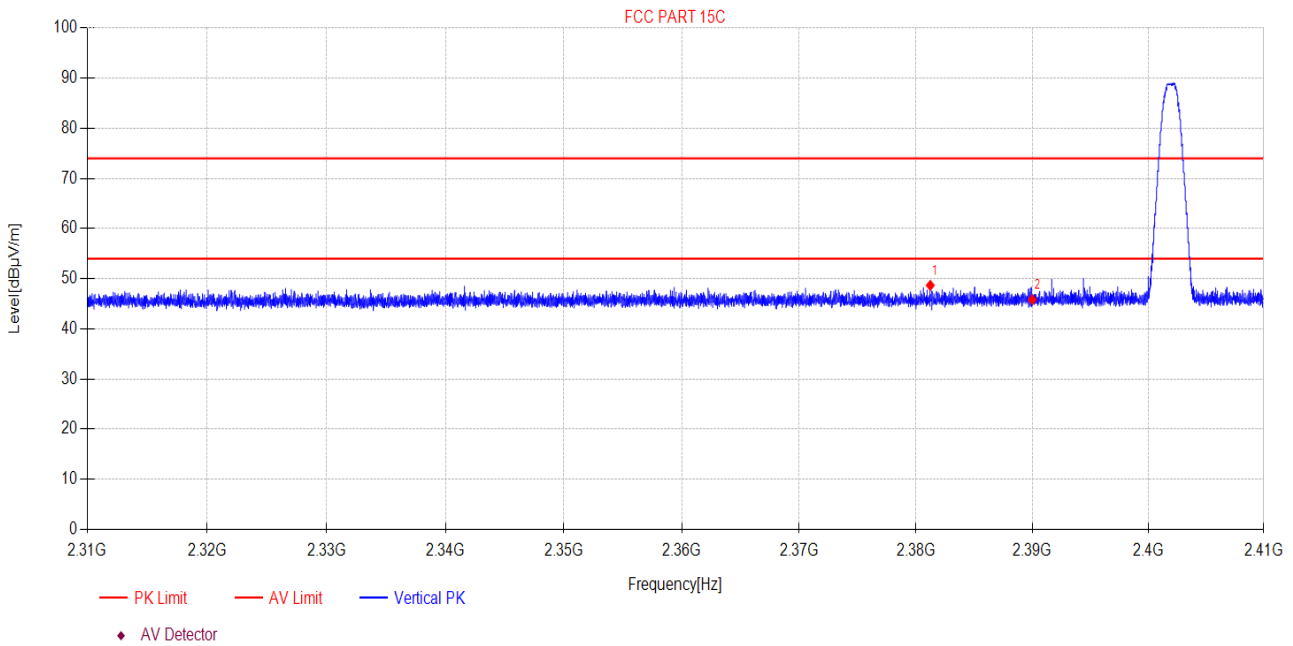

Suspected Data List								
NO.	Freq. [MHz]	Reading [dBµV]	Factor [dB]	Level [dBµV/m]	Limit [dBµV/m]	Margin [dB]	Detector	Polarity
1	2381.23	48.41	0.26	48.67	74.00	25.33	PK	Vertical
2	2390.00	45.55	0.28	45.83	74.00	28.17	PK	Vertical

Note:
 1. Level = Reading + Factor.
 2. If Peak Result complies with AV limit, AV Result is deemed to comply with AV limit.
 3. Test setup: RBW: 1 MHz, VBW: 3 MHz, Sweep time: auto.

TR-4-E-009 Radiated Emission Test Result

Test Date: 2022-11-04 **Tested By:** James Gan
EUT: BLUETOOTH HEADSET **Model Number:** TOUR PRO 2
Test Mode: Tx mode **Power Supply:** Battery
Condition: Temp:22.2°C;Humi:56.7%;Press:100.3kPa **Test Site:** DDT 3# Chamber
File Path: d:\ts\2022 report data\Q22092806-2E TOUR PRO2\FCC ABOVE 1G\49
Memo: BLE 1M 2480

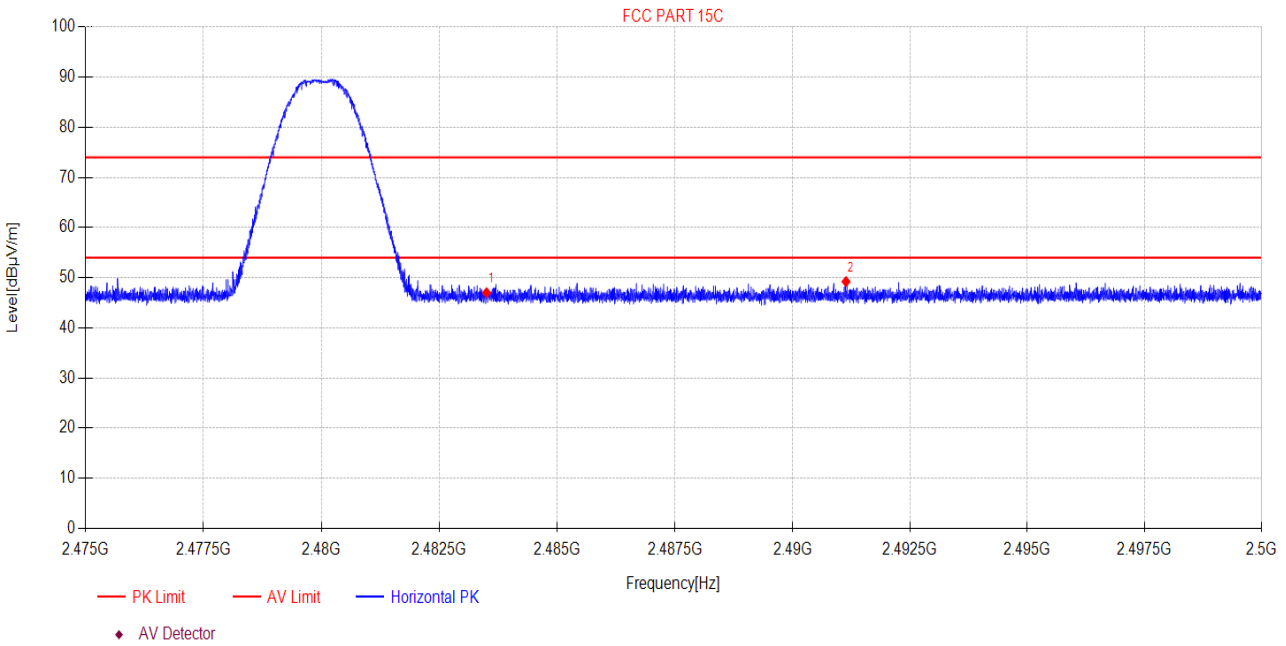

Suspected Data List								
NO.	Freq. [MHz]	Reading [dBµV]	Factor [dB]	Level [dBµV/m]	Limit [dBµV/m]	Margin [dB]	Detector	Polarity
1	2483.50	46.47	0.54	47.01	74.00	26.99	PK	Horizontal
2	2491.14	48.65	0.57	49.22	74.00	24.78	PK	Horizontal

- Note:
1. Level = Reading + Factor.
 2. If Peak Result complies with AV limit, AV Result is deemed to comply with AV limit.
 3. Test setup: RBW: 1 MHz, VBW: 3 MHz, Sweep time: auto.

TR-4-E-009 Radiated Emission Test Result

Test Date: 2022-11-04 **Tested By:** James Gan
EUT: BLUETOOTH HEADSET **Model Number:** TOUR PRO 2
Test Mode: Tx mode **Power Supply:** Battery
Condition: Temp:22.2°C;Humi:56.7%;Press:100.3kPa **Test Site:** DDT 3# Chamber
File Path: d:\ts\2022 report data\Q22092806-2E TOUR PRO2\FCC ABOVE 1G\50
Memo: BLE 1M 2480

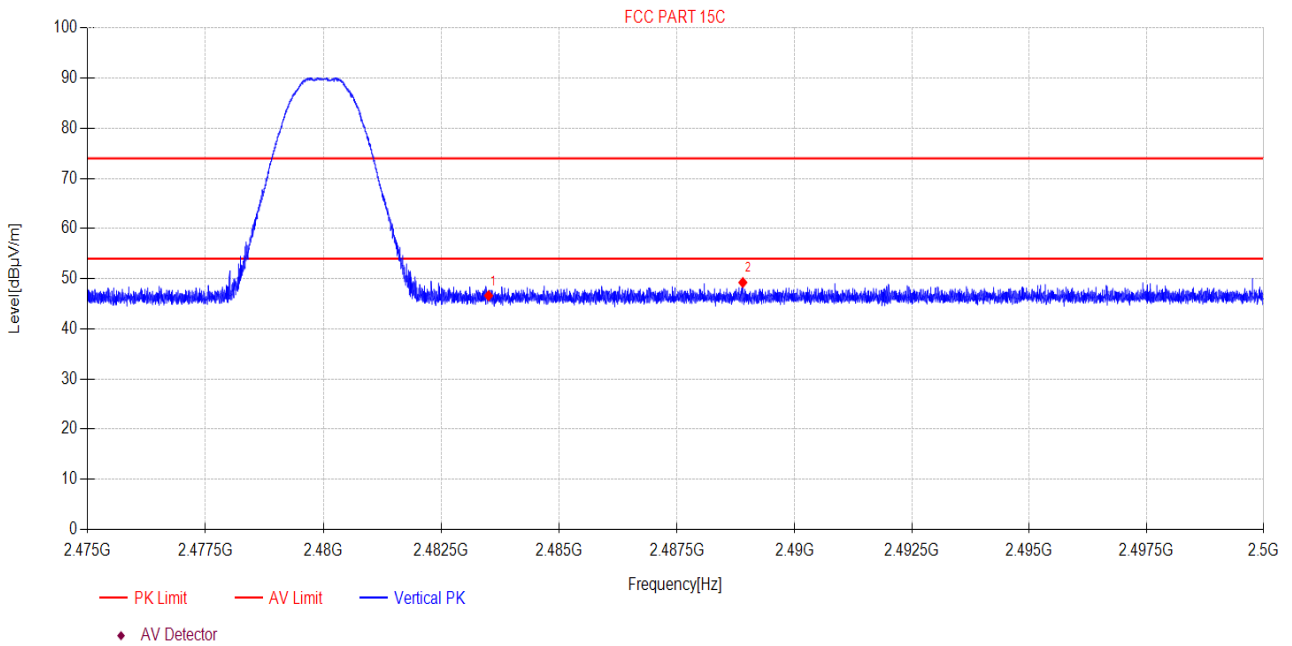

Suspected Data List								
NO.	Freq. [MHz]	Reading [dBµV]	Factor [dB]	Level [dBµV/m]	Limit [dBµV/m]	Margin [dB]	Detector	Polarity
1	2483.50	46.08	0.54	46.62	74.00	27.38	PK	Vertical
2	2488.90	48.67	0.57	49.24	74.00	24.76	PK	Vertical

Note:
 1. Level = Reading + Factor.
 2. If Peak Result complies with AV limit, AV Result is deemed to comply with AV limit.
 3. Test setup: RBW: 1 MHz, VBW: 3 MHz, Sweep time: auto.

TR-4-E-009 Radiated Emission Test Result

Test Date: 2022-11-04 **Tested By:** James Gan
EUT: BLUETOOTH HEADSET **Model Number:** TOUR PRO 2
Test Mode: Tx mode **Power Supply:** Battery
Condition: Temp:22.2°C;Humi:56.7%;Press:100.3kPa **Test Site:** DDT 3# Chamber
File Path: d:\ts\2022 report data\Q22092806-2E TOUR PRO2\FCC ABOVE 1G\55
Memo: BLE 2M 2402

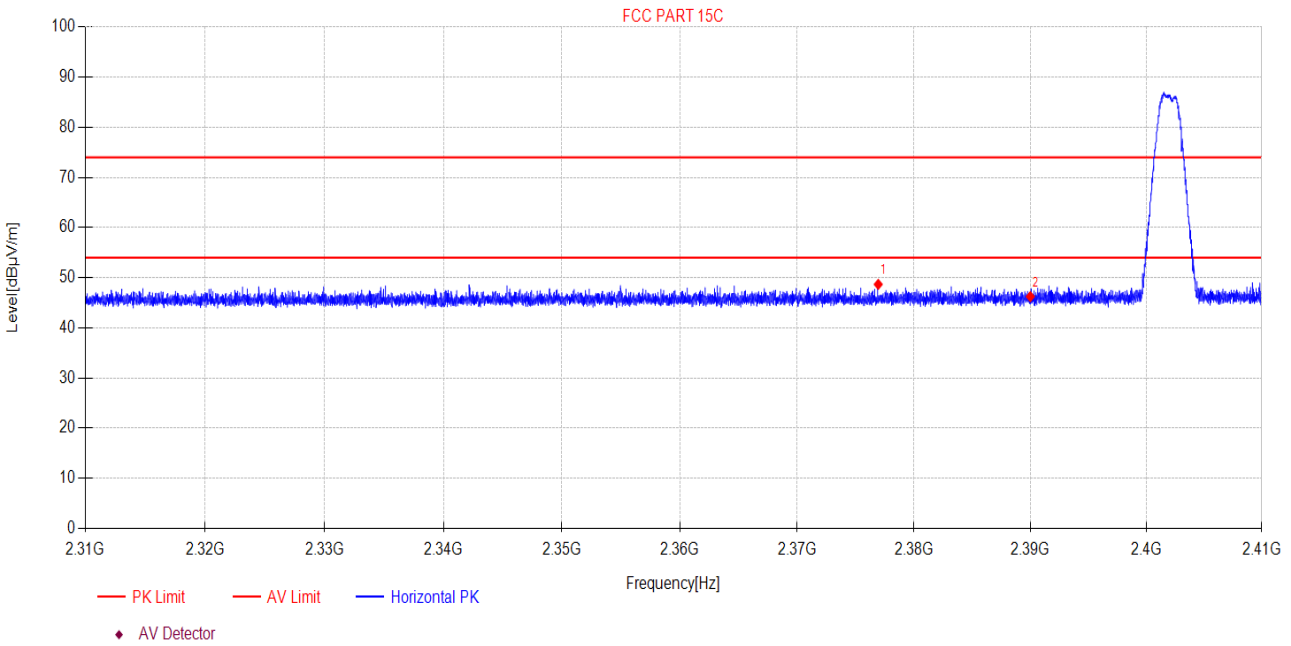

Suspected Data List								
NO.	Freq. [MHz]	Reading [dBµV]	Factor [dB]	Level [dBµV/m]	Limit [dBµV/m]	Margin [dB]	Detector	Polarity
1	2376.94	48.42	0.25	48.67	74.00	25.33	PK	Horizontal
2	2390.00	45.96	0.28	46.24	74.00	27.76	PK	Horizontal

Note:
 1. Level = Reading + Factor.
 2. If Peak Result complies with AV limit, AV Result is deemed to comply with AV limit.
 3. Test setup: RBW: 1 MHz, VBW: 3 MHz, Sweep time: auto.

TR-4-E-009 Radiated Emission Test Result

Test Date: 2022-11-04 **Tested By:** James Gan
EUT: BLUETOOTH HEADSET **Model Number:** TOUR PRO 2
Test Mode: Tx mode **Power Supply:** Battery
Condition: Temp:22.2°C;Humi:56.7%;Press:100.3kPa **Test Site:** DDT 3# Chamber
File Path: d:\ts\2022 report data\Q22092806-2E TOUR PRO2\FCC ABOVE 1G\56
Memo: BLE 2M 2402

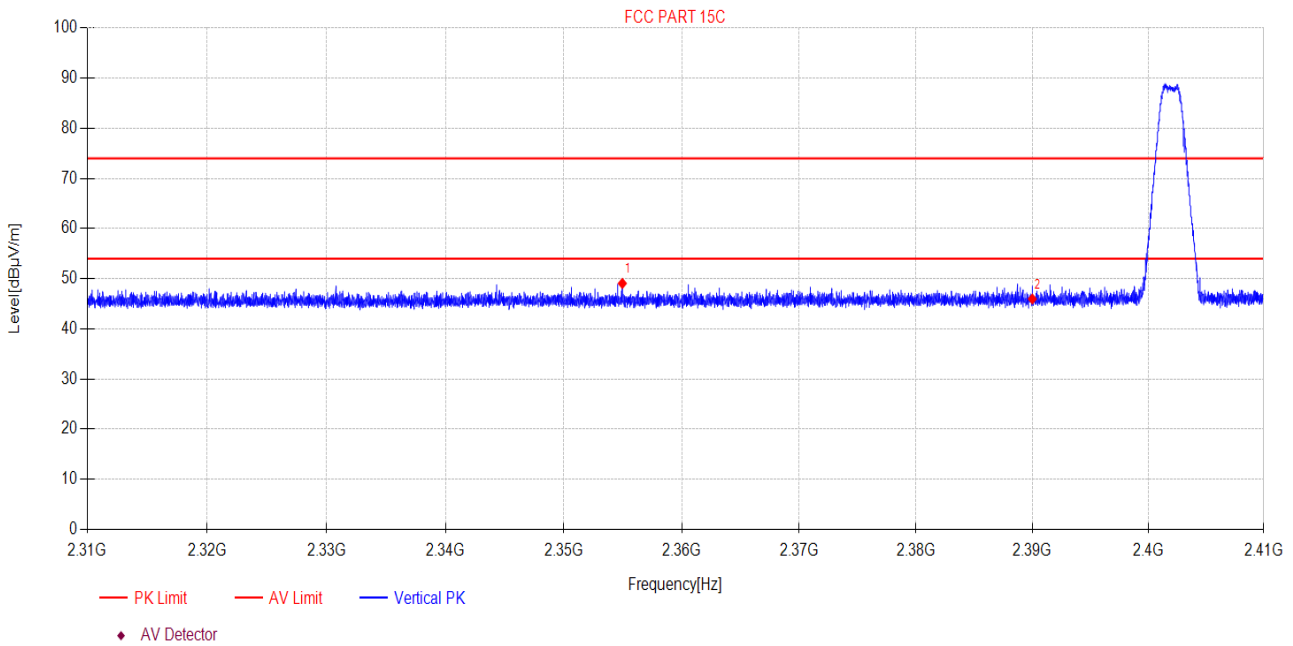

Suspected Data List								
NO.	Freq. [MHz]	Reading [dBµV]	Factor [dB]	Level [dBµV/m]	Limit [dBµV/m]	Margin [dB]	Detector	Polarity
1	2354.96	48.85	0.21	49.06	74.00	24.94	PK	Vertical
2	2390.00	45.68	0.28	45.96	74.00	28.04	PK	Vertical

Note:
 1. Level = Reading + Factor.
 2. If Peak Result complies with AV limit, AV Result is deemed to comply with AV limit.
 3. Test setup: RBW: 1 MHz, VBW: 3 MHz, Sweep time: auto.

TR-4-E-009 Radiated Emission Test Result

Test Date: 2022-11-04 **Tested By:** James Gan
EUT: BLUETOOTH HEADSET **Model Number:** TOUR PRO 2
Test Mode: Tx mode **Power Supply:** Battery
Condition: Temp:22.2°C;Humi:56.7%;Press:100.3kPa **Test Site:** DDT 3# Chamber
File Path: d:\ts\2022 report data\Q22092806-2E TOUR PRO2\FCC ABOVE 1G\51
Memo: BLE 2M 2480

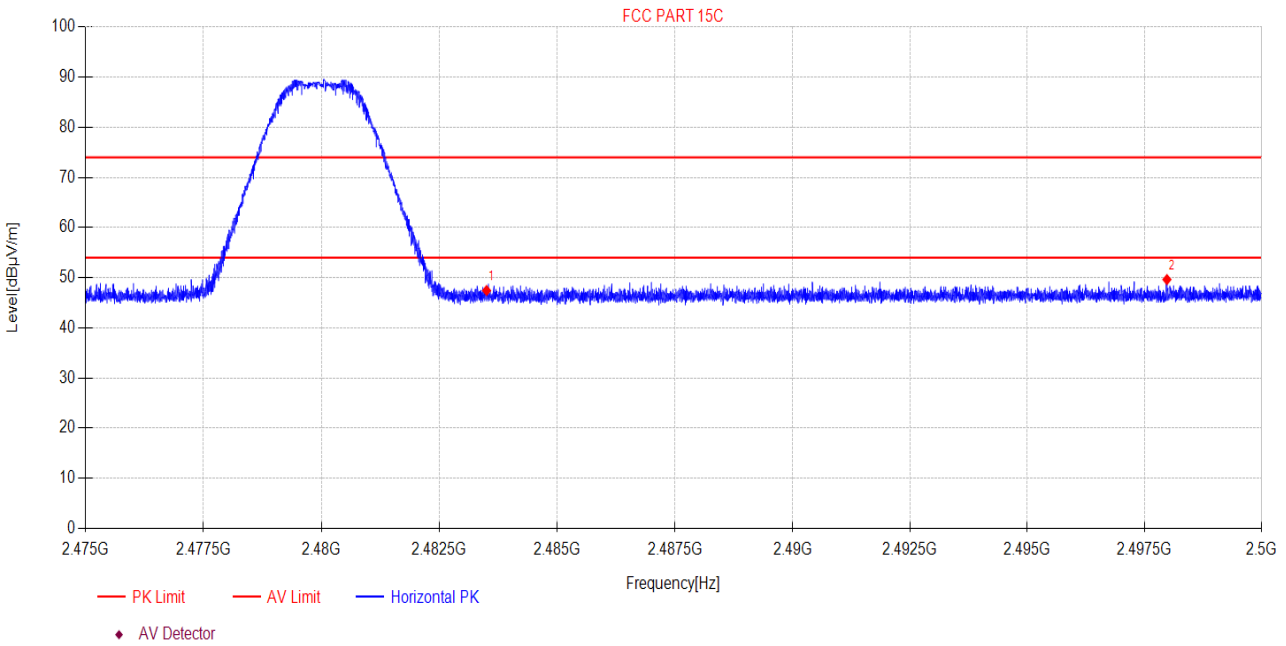

Suspected Data List								
NO.	Freq. [MHz]	Reading [dBµV]	Factor [dB]	Level [dBµV/m]	Limit [dBµV/m]	Margin [dB]	Detector	Polarity
1	2483.50	46.91	0.54	47.45	74.00	26.55	PK	Horizontal
2	2497.98	49.03	0.60	49.63	74.00	24.37	PK	Horizontal

- Note:
1. Level = Reading + Factor.
 2. If Peak Result complies with AV limit, AV Result is deemed to comply with AV limit.
 3. Test setup: RBW: 1 MHz, VBW: 3 MHz, Sweep time: auto.

TR-4-E-009 Radiated Emission Test Result

Test Date: 2022-11-04 **Tested By:** James Gan
EUT: BLUETOOTH HEADSET **Model Number:** TOUR PRO 2
Test Mode: Tx mode **Power Supply:** Battery
Condition: Temp:22.2°C;Humi:56.7%;Press:100.3kPa **Test Site:** DDT 3# Chamber
File Path: d:\ts\2022 report data\Q22092806-2E TOUR PRO2\FCC ABOVE 1G\52
Memo: BLE 2M 2480

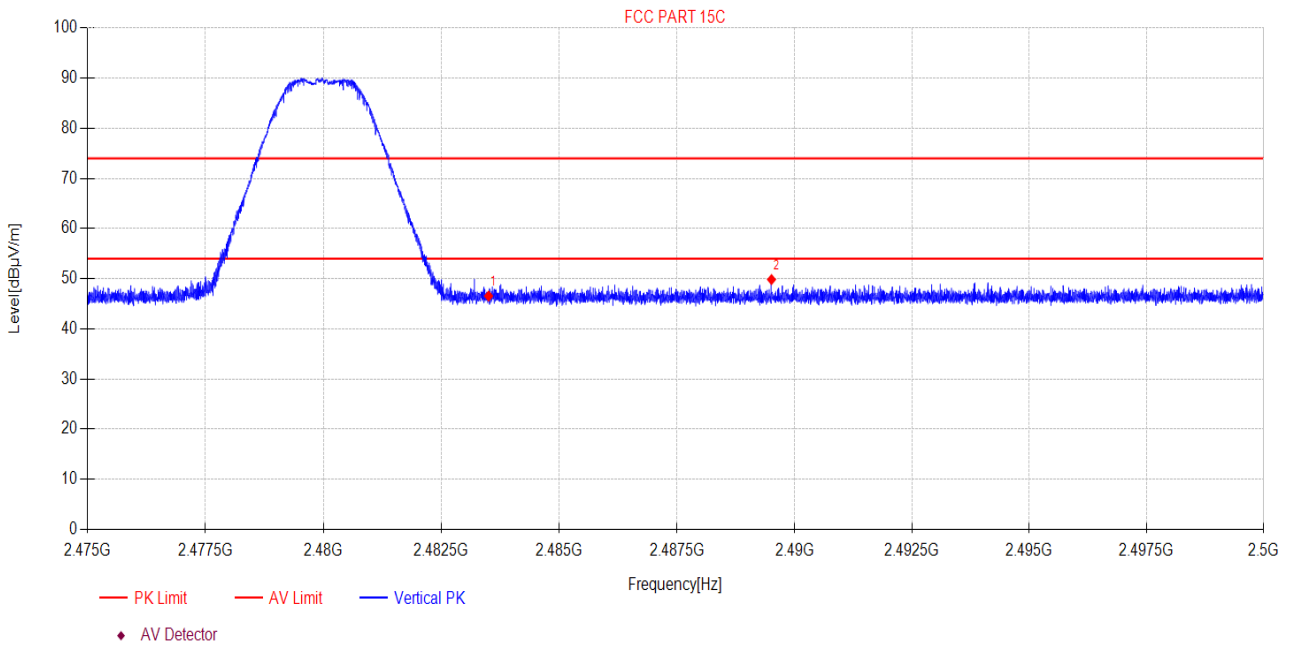

Suspected Data List								
NO.	Freq. [MHz]	Reading [dBµV]	Factor [dB]	Level [dBµV/m]	Limit [dBµV/m]	Margin [dB]	Detector	Polarity
1	2483.50	46.01	0.54	46.55	74.00	27.45	PK	Vertical
2	2489.51	49.26	0.57	49.83	74.00	24.17	PK	Vertical

- Note:
1. Level = Reading + Factor.
 2. If Peak Result complies with AV limit, AV Result is deemed to comply with AV limit.
 3. Test setup: RBW: 1 MHz, VBW: 3 MHz, Sweep time: auto.

11. Power Line Conducted Emission

11.1. Block diagram of test setup

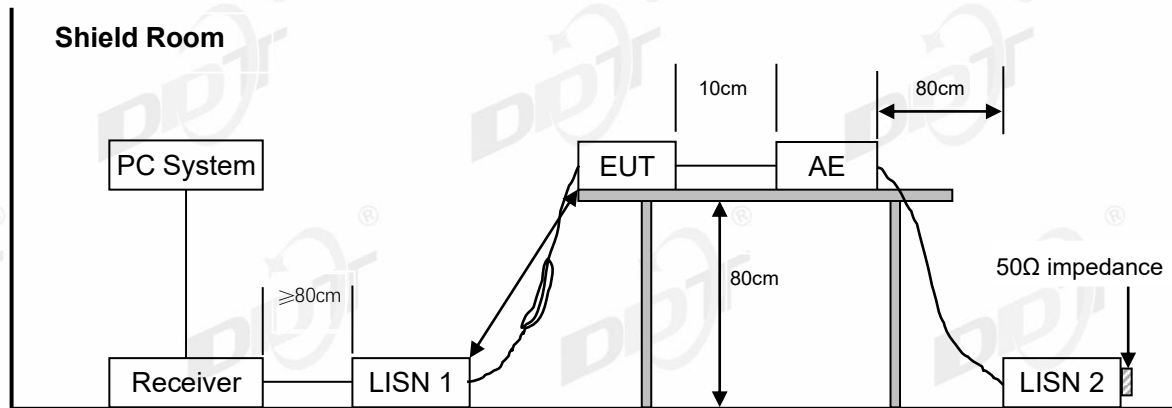

11.2. Power line conducted emission limits

Frequency	Quasi-Peak Level dB(μ V)	Average Level dB(μ V)
150 kHz ~ 500 kHz	66 ~ 56*	56 ~ 46*
500 kHz ~ 5 MHz	56	46
5 MHz ~ 30 MHz	60	50

Note 1: * Decreasing linearly with logarithm of frequency.

Note 2: The lower limit shall apply at the transition frequencies.

11.3. Test procedure

The EUT and Support equipment, if needed, were put placed on a non-metallic table, 80cm above the ground plane.

All support equipment power received from a second LISN.

Emissions were measured on each current carrying line of the EUT using an EMI Test Receiver connected to the LISN powering the EUT.

The Receiver scanned from 150 kHz to 30 MHz for emissions in each of the test modes.

During the above scans, the emissions were maximized by cable manipulation.

The test mode(s) described in clause 2.4 were scanned during the preliminary test.

After the preliminary scan, we found the test mode producing the highest emission level.

The EUT configuration and worse cable configuration of the above highest emission levels were recorded for reference of the final test.

EUT and support equipment were set up on the test bench as per the configuration with highest emission level in the preliminary test.

A scan was taken on both power lines, Neutral and Line, recording at least the six highest emissions.

Emission frequency and amplitude were recorded into a computer in which correction factors were used to calculate the emission level and compare reading to the applicable limit.

The test data of the worst-case condition(s) was recorded.

The bandwidth of test receiver is set at 9 kHz.

11.4. Test result

Pass. (See below detailed test result)

Note1: All emissions not reported below are too low against the prescribed limits.

Note2: "----" means Peak detection; "----" means Average detection.

Note3: Pre-test AC conducted emission at both voltage AC 120V/60Hz and AC 240V/50Hz, recorded worse case.

TR-4-E-010 Conducted Emission Test Result

Test Site : DDT 1# Shield Room

D:\2022 CE report date\Q22092806-2E TOUR PRO 2\FCC.EM6

Test Date : 2022-11-08

Tested By : James Gan

EUT : BLUETOOTH HEADSET

Model Number : TOUR PRO 2

Power Supply : AC 120V/60Hz

Test Mode : Tx mode

Condition : TEMP:22.3°C, RH:53.8%, BP:100.3KPa

LISN : 2021 1# ENV216/LINE

Memo :

Data: 4

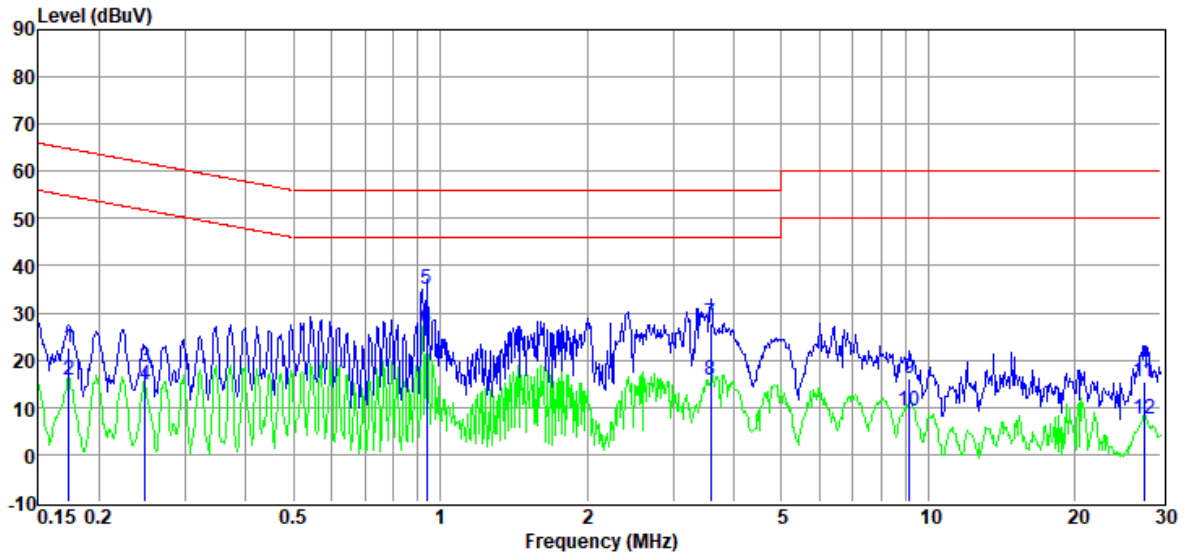

Item (Mark)	Freq. (MHz)	Read Level (dBμV)	LISN Factor (dB)	Cable Loss (dB)	Pulse Limiter Factor (dB)	Result Level (dBμV)	Limit Line (dBμV)	Over Limit (dB)	Detector	Phase
1	0.17	2.88	9.70	0.01	9.92	22.51	64.81	-42.30	QP	LINE
2	0.17	-3.86	9.70	0.01	9.92	15.77	54.81	-39.04	Average	LINE
3	0.25	-1.16	9.75	0.02	9.92	18.53	61.82	-43.29	QP	LINE
4	0.25	-5.09	9.75	0.02	9.92	14.60	51.82	-37.22	Average	LINE
5	0.94	15.40	9.58	0.03	9.89	34.90	56.00	-21.10	QP	LINE
6	0.94	7.22	9.58	0.03	9.89	26.72	46.00	-19.28	Average	LINE
7	3.58	8.14	9.58	0.05	9.92	27.69	56.00	-28.31	QP	LINE
8	3.58	-3.89	9.58	0.05	9.92	15.66	46.00	-30.34	Average	LINE
9	9.16	-3.49	9.50	0.10	9.94	16.05	60.00	-43.95	QP	LINE
10	9.16	-10.18	9.50	0.10	9.94	9.36	50.00	-40.64	Average	LINE
11	27.71	-4.38	9.68	0.20	9.99	15.49	60.00	-44.51	QP	LINE
12	27.71	-12.19	9.68	0.20	9.99	7.68	50.00	-42.32	Average	LINE

Note:

1. Result Level = Read Level + LISN Factor + Pulse Limiter Factor + Cable loss.
2. If QP Result complies with AV limit, AV Result is deemed to comply with AV limit.
3. Test setup: RBW: 200 Hz (9 kHz—150 kHz), 9 kHz (150 kHz—30 MHz).
4. Step size: 80Hz (0.009MHz-0.15MHz), 4 kHz (0.15MHz-30MHz), Scan time: auto.

TR-4-E-010 Conducted Emission Test Result

Test Site : DDT 1# Shield Room D:\2022 CE report date\Q22092806-2E TOUR PRO 2\FCC.EM6
Test Date : 2022-11-08 **Tested By** : James Gan
EUT : BLUETOOTH HEADSET **Model Number** : TOUR PRO 2
Power Supply : AC 120V/60Hz **Test Mode** : Tx mode
Condition : TEMP:22.3°C, RH:53.8%, BP:100.3KPa **LISN** : 2021 1# ENV216/NEUTRAL

Memo :

Data: 10

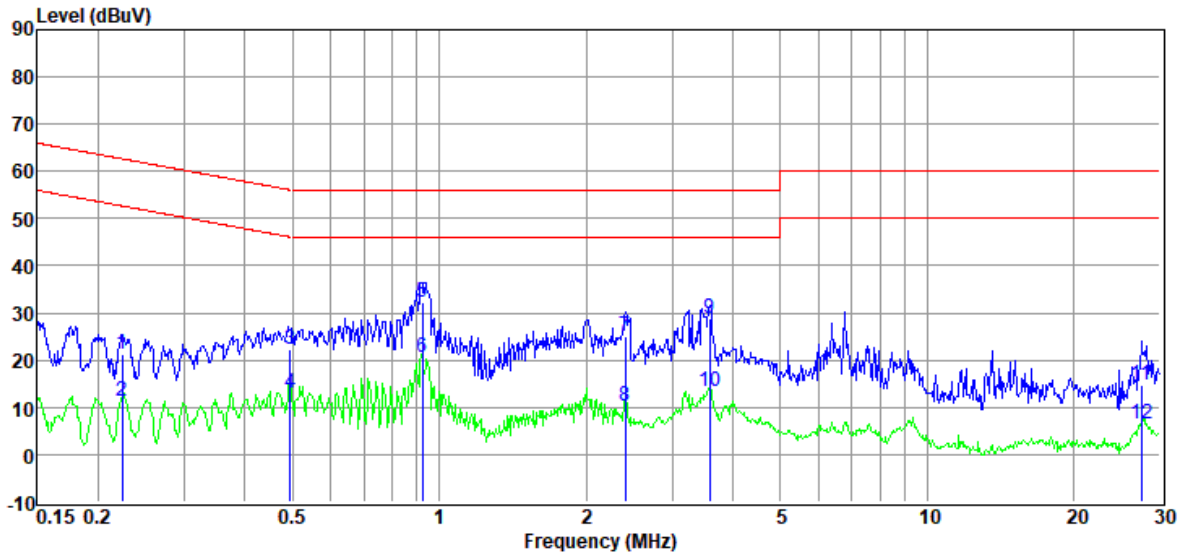

Item (Mark)	Freq. (MHz)	Read Level (dBuV)	LISN Factor (dB)	Cable Loss (dB)	Pulse Limiter Factor (dB)	Result Level (dBuV)	Limit Line (dBuV)	Over Limit (dB)	Detector	Phase
1	0.22	1.55	9.76	0.02	9.92	21.25	62.66	-41.41	QP	NEUTRAL
2	0.22	-8.49	9.76	0.02	9.92	11.21	52.66	-41.45	Average	NEUTRAL
3	0.49	2.87	9.50	0.02	9.91	22.30	56.10	-33.80	QP	NEUTRAL
4	0.49	-6.57	9.50	0.02	9.91	12.86	46.10	-33.24	Average	NEUTRAL
5	0.92	12.79	9.72	0.03	9.89	32.43	56.00	-23.57	QP	NEUTRAL
6	0.92	0.97	9.72	0.03	9.89	20.61	46.00	-25.39	Average	NEUTRAL
7	2.41	5.62	9.65	0.05	9.90	25.22	56.00	-30.78	QP	NEUTRAL
8	2.41	-9.46	9.65	0.05	9.90	10.14	46.00	-35.86	Average	NEUTRAL
9	3.58	9.07	9.77	0.05	9.92	28.81	56.00	-27.19	QP	NEUTRAL
10	3.58	-6.48	9.77	0.05	9.92	13.26	46.00	-32.74	Average	NEUTRAL
11	27.42	-5.41	9.88	0.20	9.99	14.66	60.00	-45.34	QP	NEUTRAL
12	27.42	-13.47	9.88	0.20	9.99	6.60	50.00	-43.40	Average	NEUTRAL

Note:

1. Result Level = Read Level + LISN Factor + Pulse Limiter Factor + Cable loss.
2. If QP Result complies with AV limit, AV Result is deemed to comply with AV limit.
3. Test setup: RBW: 200 Hz (9 kHz—150 kHz), 9 kHz (150 kHz—30 MHz).
4. Step size: 80Hz (0.009MHz-0.15MHz), 4 kHz (0.15MHz-30MHz), Scan time: auto.

12. Antenna Requirements

12.1. Limit

For intentional device, according to FCC 47 CFR Section 15.203, an intentional radiator shall be designed to ensure that no antenna other than that furnished by the responsible party shall be used with the device. And according to FCC 47 CFR Section 15.247 (b), if transmitting antennas of directional gain greater than 6 dBi are used, the power shall be reduced by the amount in dB that the directional gain of the antenna exceeds 6 dBi.

For intentional device, according to RSS-Gen issue 5 section 6.8.

The applicant for equipment certification shall provide a list of all antenna types that may be used with the transmitter, where applicable (i.e. for transmitters with detachable antenna), indicating the maximum permissible antenna gain (in dBi) and the required impedance for each antenna. The test report shall demonstrate the compliance of the transmitter with the limit for maximum equivalent isotropically radiated power (e.i.r.p.) specified in the applicable RSS, when the transmitter is equipped with any antenna type, selected from this list.

12.2. Result

The product is that no antenna other than that furnished by the responsible party shall be used with the device, the maximum peak gain of the left side transmit antenna is -0.33 dBi and right side is -0.65 dBi.

END OF REPORT