

# TR-4-E-009 Radiated Emission Test Result

**Test Date:** 2024-02-01      **Tested By:** Bairong  
**EUT:** Wireless Speaker      **Model Number:** CHARGE 5 Wi-Fi  
**Test Mode:** 11AX40MIMO 2422MHz TX      **Power Supply:** AC 120V/60Hz  
**Condition:** Temp:21.5°C;Humi:39.7%      **Test Site:** DDT 3# Chamber  
**File Path:** d:\ts\2024 report data\Q23111313-2E CHARGE 5 Wi-Fi\FCC ABOVE 1G 2.4GWIFI\38  
**Memo:** Sample Number:S23111313-02 Power Setting:15

## Test Graph

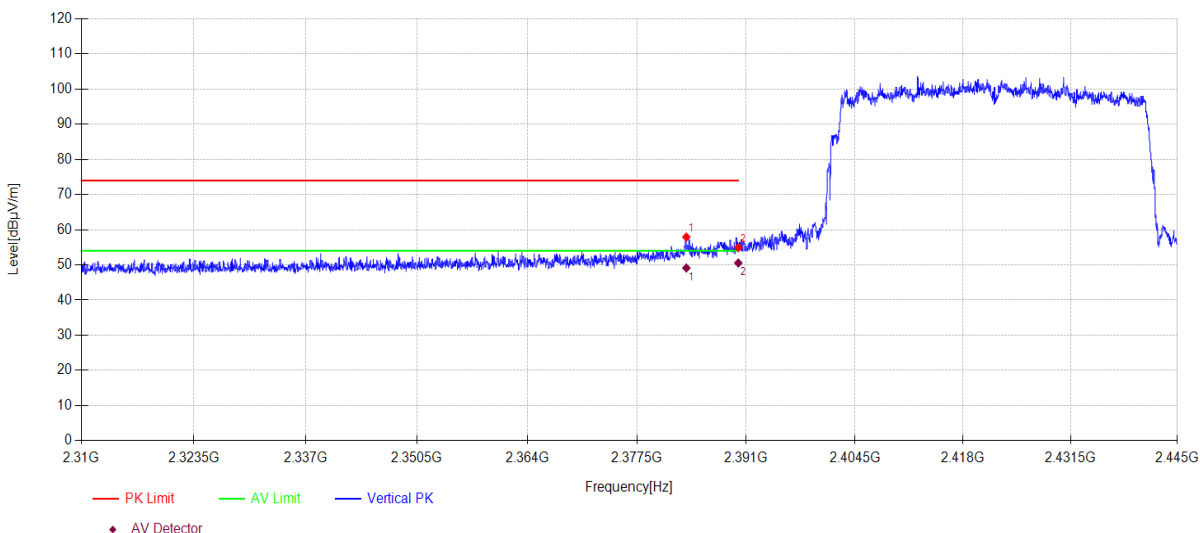

Data List										
NO	Freq. [MHz]	Reading [dBµV/m]	Antenna Factor [dB]	Cable loss [dB]	AMP [dB]	Level [dBµV/m]	Limit [dBµV/m]	Margin [dB]	Detector	Polarity
1	2383.58	26.83	27.23	3.86	0.00	57.92	74.00	16.08	PK	Vertical
2	2390.00	23.79	27.26	3.87	0.00	54.92	74.00	19.08	PK	Vertical

Data List										
NO	Freq. [MHz]	Reading [dBµV/m]	Antenna Factor [dB]	Cable loss [dB]	AMP [dB]	Level [dBµV/m]	Limit [dBµV/m]	Margin [dB]	Detector	Polarity
1	2383.58	18.03	27.23	3.86	0.00	49.12	54.00	4.88	AV	Vertical
2	2390.00	19.41	27.26	3.87	0.00	50.54	54.00	3.46	AV	Vertical

**Note:**

1. Level = Reading + Cable loss + Antenna Factor + AMP
2. If Peak Result complies with AV limit, AV Result is deemed to comply with AV limit.
3. Test setup: RBW: 1 MHz, VBW: 3 MHz, Sweep time: auto.

# TR-4-E-009 Radiated Emission Test Result

**Test Date:** 2024-02-01 **Tested By:** Bairong  
**EUT:** Wireless Speaker **Model Number:** CHARGE 5 Wi-Fi  
**Test Mode:** 11AX40MIMO 2452MHz TX **Power Supply:** AC 120V/60Hz  
**Condition:** Temp:21.5°C;Humi:39.7% **Test Site:** DDT 3# Chamber  
**File Path:** d:\ts\2024 report data\Q23111313-2E CHARGE 5 Wi-Fi\FCC ABOVE 1G 2.4GWIFI\39  
**Memo:** Sample Number:S23111313-02 Power Setting:15

## Test Graph

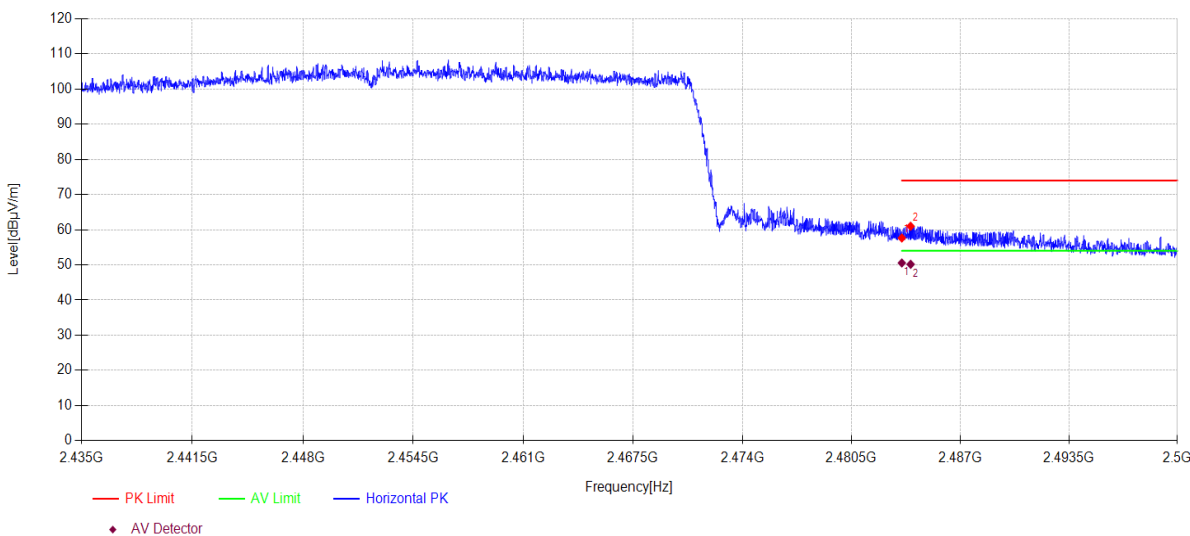

Data List										
NO	Freq. [MHz]	Reading [dBµV/m]	Antenna Factor [dB]	Cable loss [dB]	AMP [dB]	Level [dBµV/m]	Limit [dBµV/m]	Margin [dB]	Detector	Polarity
1	2483.50	26.17	27.53	3.94	0.00	57.64	74.00	16.36	PK	Horizontal
2	2484.02	29.51	27.54	3.94	0.00	60.99	74.00	13.01	PK	Horizontal

Data List										
NO	Freq. [MHz]	Reading [dBµV/m]	Antenna Factor [dB]	Cable loss [dB]	AMP [dB]	Level [dBµV/m]	Limit [dBµV/m]	Margin [dB]	Detector	Polarity
1	2483.50	19.08	27.53	3.94	0.00	50.55	54.00	3.45	AV	Horizontal
2	2484.02	18.69	27.54	3.94	0.00	50.17	54.00	3.83	AV	Horizontal

**Note:**

1. Level = Reading + Cable loss + Antenna Factor + AMP
2. If Peak Result complies with AV limit, AV Result is deemed to comply with AV limit.
3. Test setup: RBW: 1 MHz, VBW: 3 MHz, Sweep time: auto.

# TR-4-E-009 Radiated Emission Test Result

**Test Date:** 2024-02-01 **Tested By:** Bairong  
**EUT:** Wireless Speaker **Model Number:** CHARGE 5 Wi-Fi  
**Test Mode:** 11AX40MIMO 2452MHz TX **Power Supply:** AC 120V/60Hz  
**Condition:** Temp:21.5°C;Humi:39.7% **Test Site:** DDT 3# Chamber  
**File Path:** d:\ts\2024 report data\Q23111313-2E CHARGE 5 Wi-Fi\FCC ABOVE 1G 2.4GWIFI40  
**Memo:** Sample Number:S23111313-02 Power Setting:15

## Test Graph

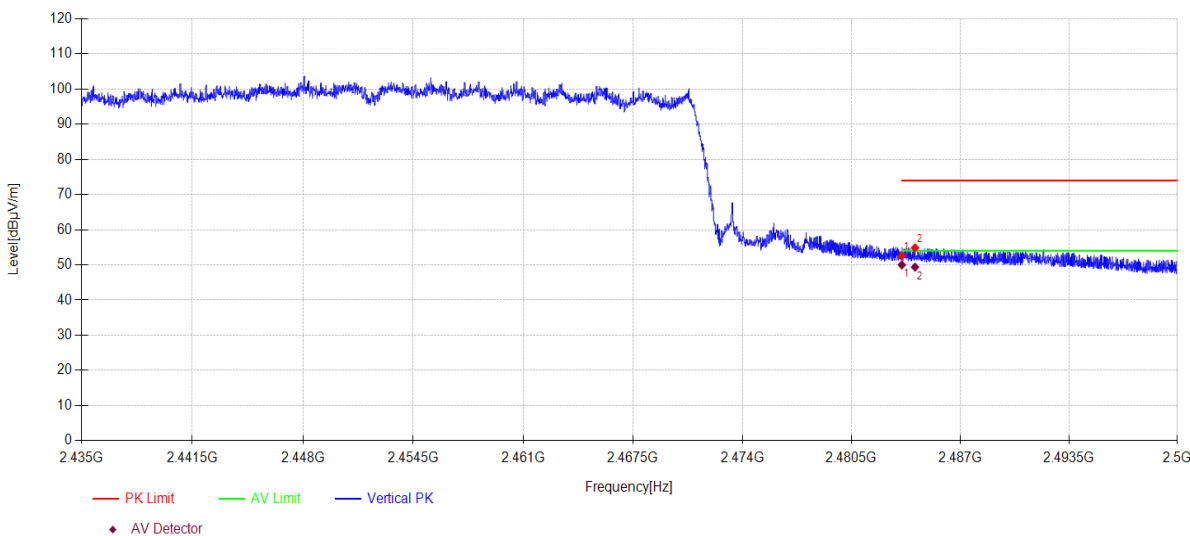

Data List										
NO	Freq. [MHz]	Reading [dBµV/m]	Antenna Factor [dB]	Cable loss [dB]	AMP [dB]	Level [dBµV/m]	Limit [dBµV/m]	Margin [dB]	Detector	Polarity
1	2483.50	21.13	27.53	3.94	0.00	52.60	74.00	21.40	PK	Vertical
2	2484.29	23.37	27.54	3.94	0.00	54.85	74.00	19.15	PK	Vertical

Data List										
NO	Freq. [MHz]	Reading [dBµV/m]	Antenna Factor [dB]	Cable loss [dB]	AMP [dB]	Level [dBµV/m]	Limit [dBµV/m]	Margin [dB]	Detector	Polarity
1	2483.50	18.52	27.53	3.94	0.00	49.99	54.00	4.01	AV	Vertical
2	2484.29	17.89	27.54	3.94	0.00	49.37	54.00	4.63	AV	Vertical

**Note:**

1. Level = Reading + Cable loss + Antenna Factor + AMP
2. If Peak Result complies with AV limit, AV Result is deemed to comply with AV limit.
3. Test setup: RBW: 1 MHz, VBW: 3 MHz, Sweep time: auto.

## 14. Power Line Conducted Emissions

### 14.1. Test equipment

Equipment	Manufacturer	Model No.	Serial No.	Cal Due To
Pulse Limiter	SCHWARZBEC K	ESH3-Z2	DDT-ZC00539	2024/07/14
Artificial mains	R&S	ESH2-Z5	DDT-ZC00538	2024/07/11
EMI Test Software	Audix/TW	e3	DDT-ZC01252	/
EMI Test Receiver	R&S	ESCI	DDT-ZC00235	2024/07/10
CE Cable 1	R&S	ESU8/RF2	DDT-ZC00566	2024/07/14
Two Line V-Network	R&S	ENV216	DDT-ZC00535	2024/07/10

### 14.2. Block diagram of test setup

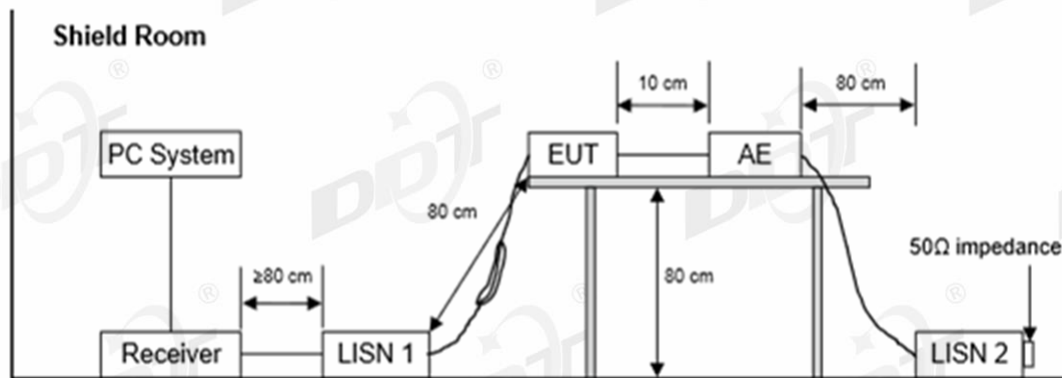

### 14.3. Limits

Frequency	Quasi-Peak Level dB(mV)	Average Level dB(mV)
150 kHz~500 kHz	66 ~ 56*	56 ~ 46*
500 kHz~5 MHz	56	46
5 MHz~30 MHz	60	50

Note 1: \* Decreasing linearly with logarithm of frequency.

Note 2: The lower limit shall apply at the transition frequencies.

### 14.4. Assistant equipment used for test

Assistant equipment	Manufacturer	Model number	Description	other
Adapter	SAMSUNG	EP-TA200	Samsung fast charging	Input: 100-240~, 50/60Hz, 0.5A; Output: 9V/1.67A or 5V/2A

### 14.5. Test procedure

The EUT and Support equipment, if needed, were put placed on a non-metallic table, 80cm above the ground plane.

All support equipment power received from a second LISN.

Emissions were measured on each current carrying line of the EUT using an EMI Test Receiver connected to the LISN powering the EUT.

The Receiver scanned from 150 kHz to 30 MHz for emissions in each of the test modes.

During the above scans, the emissions were maximized by cable manipulation.

The test mode(s) described in clause 2.4 were scanned during the preliminary test.

After the preliminary scan, we found the test mode producing the highest emission level.

The EUT configuration and worse cable configuration of the above highest emission levels were recorded for reference of the final test.

EUT and support equipment were set up on the test bench as per the configuration with highest emission level in the preliminary test.

A scan was taken on both power lines, Neutral and Line, recording at least the six highest emissions.

Emission frequency and amplitude were recorded into a computer in which correction factors were used to calculate the emission level and compare reading to the applicable limit.

The test data of the worst-case condition(s) was recorded.

The bandwidth of test receiver is set at 9 kHz.

#### **14.6. Test result**

##### **PASS. (See below detailed test result)**

Note1: All emissions not reported below are too low against the prescribed limits.

Note2: "----" means Peak detection; "----" means Average detection.

Note3: Pre-test AC conducted emission at both voltage AC 120V/60Hz and AC 240V/50Hz, recorded the worst case.



14.7. Test data

TR-4-E-010 Conducted Emission Test Result

**Test Site** : DDT 1# Shield Room D:\2024 CE report data\Q23111313-2E CHARGE5 WIFI\FCC CE.EM6  
**Test Date** : 2024-02-18 **Tested By** : Bairong  
**EUT** : Wireless Speaker **Model Number** : CHARGE 5 Wi-Fi  
**Power Supply** : AC 120V/60Hz **Test Mode** : 2.4G WIFI mode  
**Condition** : TEMP:22.3°C, RH:56.5% **LISN** : 2023 1# ENV216/NEUTRAL  
**Memo** : Sample Number:S23111313-01

Data: 14

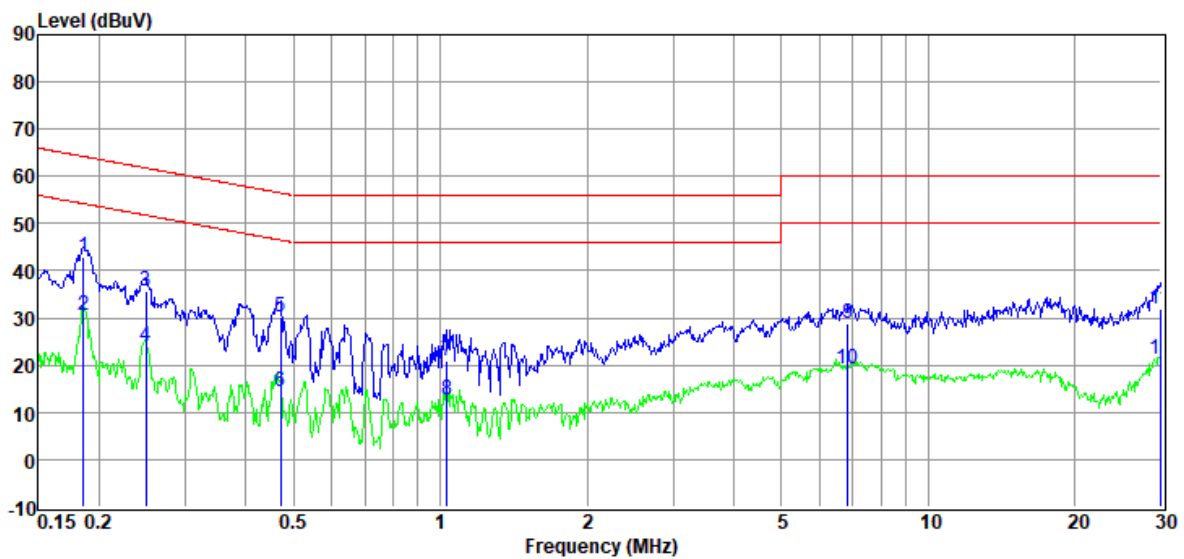

Item (Mark)	Freq. (MHz)	Read Level (dBuV)	LISN Factor (dB)	Cable Loss (dB)	Pulse Limiter Factor (dB)	Result Level (dBuV)	Limit Line (dBuV)	Over Limit (dB)	Detector	Phase
1	0.19	22.59	9.79	0.91	9.69	42.98	64.24	-21.26	QP	NEUTRAL
2	0.19	10.17	9.79	0.91	9.69	30.56	54.24	-23.68	Average	NEUTRAL
3	0.25	15.42	9.75	0.89	9.69	35.75	61.78	-26.03	QP	NEUTRAL
4	0.25	3.80	9.75	0.89	9.69	24.13	51.78	-27.65	Average	NEUTRAL
5	0.47	9.88	9.78	0.86	9.71	30.23	56.49	-26.26	QP	NEUTRAL
6	0.47	-5.89	9.78	0.86	9.71	14.46	46.49	-32.03	Average	NEUTRAL
7	1.03	0.83	9.76	0.67	9.73	20.99	56.00	-35.01	QP	NEUTRAL
8	1.03	-7.61	9.76	0.67	9.73	12.55	46.00	-33.45	Average	NEUTRAL
9	6.84	8.63	9.81	0.45	9.81	28.70	60.00	-31.30	QP	NEUTRAL
10	6.84	-0.73	9.81	0.45	9.81	19.34	50.00	-30.66	Average	NEUTRAL
11	29.84	11.39	10.12	0.50	9.91	31.92	60.00	-28.08	QP	NEUTRAL
12	29.84	0.90	10.12	0.50	9.91	21.43	50.00	-28.57	Average	NEUTRAL

Note:

1. Result Level = Read Level + LISN Factor + Pulse Limiter Factor + Cable loss.
2. If QP Result complies with AV limit, AV Result is deemed to comply with AV limit.
3. Test setup: RBW: 200 Hz (9 kHz—150 kHz), 9 kHz (150 kHz—30 MHz).
4. Step size: 80Hz (0.009MHz-0.15MHz), 4 kHz (0.15MHz-30MHz), Scan time: auto.

# TR-4-E-010 Conducted Emission Test Result

**Test Site** : DDT 1# Shield Room  
**Test Date** : 2024-02-18  
**EUT** : Wireless Speaker  
**Power Supply** : AC 120V/60Hz  
**Condition** : TEMP:22.3°C, RH:56.5%  
**Memo** : Sample Number:S23111313-01

**D:\2024 CE report data\Q23111313-2E CHARGE5 WIFI\FCC CE.EM6**  
**Tested By** : Bairong  
**Model Number** : CHARGE 5 Wi-Fi  
**Test Mode** : 2.4G WIFI mode  
**LISN** : 2023 1# ENV216/LINE

Data: 16

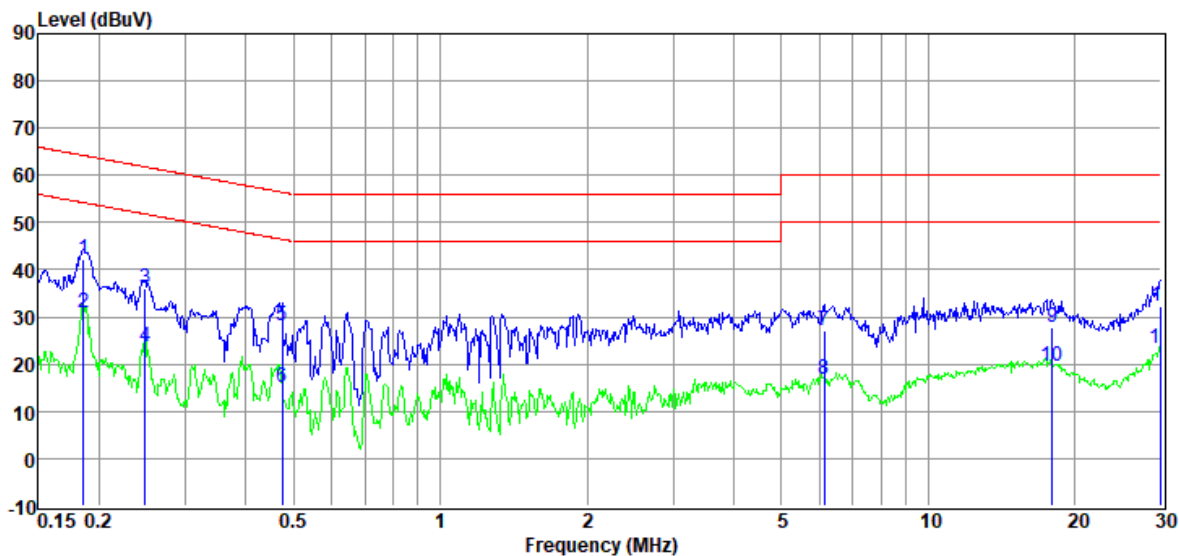

Item (Mark)	Freq. (MHz)	Read Level (dBuV)	LISN Factor (dB)	Cable Loss (dB)	Pulse Limiter Factor (dB)	Result Level (dBuV)	Limit Line (dBuV)	Over Limit (dB)	Detector	Phase
1	0.19	22.01	9.75	0.91	9.69	42.36	64.24	-21.88	QP	LINE
2	0.19	10.44	9.75	0.91	9.69	30.79	54.24	-23.45	Average	LINE
3	0.25	15.57	9.82	0.89	9.69	35.97	61.82	-25.85	QP	LINE
4	0.25	3.33	9.82	0.89	9.69	23.73	51.82	-28.09	Average	LINE
5	0.47	7.84	9.80	0.86	9.71	28.21	56.45	-28.24	QP	LINE
6	0.47	-5.37	9.80	0.86	9.71	15.00	46.45	-31.45	Average	LINE
7	6.12	6.97	9.70	0.48	9.80	26.95	60.00	-33.05	QP	LINE
8	6.12	-3.19	9.70	0.48	9.80	16.79	50.00	-33.21	Average	LINE
9	17.94	7.71	9.86	0.33	9.90	27.80	60.00	-32.20	QP	LINE
10	17.94	-0.57	9.86	0.33	9.90	19.52	50.00	-30.48	Average	LINE
11	30.00	11.82	10.20	0.50	9.91	32.43	60.00	-27.57	QP	LINE
12	30.00	2.64	10.20	0.50	9.91	23.25	50.00	-26.75	Average	LINE

**Note:**

1. Result Level = Read Level +LISN Factor + Pulse Limiter Factor + Cable loss.
2. If QP Result complies with AV limit, AV Result is deemed to comply with AV limit.
3. Test setup: RBW: 200 Hz (9 kHz—150 kHz), 9 kHz (150 kHz—30 MHz).
4. Step size: 80Hz (0.009MHz-0.15MHz), 4 kHz (0.15MHz-30MHz), Scan time: auto.