

承认书

APPROVAL SHEET

样品封订

客户名称 Customer Name GGEC

产品型号 Product Model B00MBOX3 PRO -BT

客户料号 Customer P/N _____

南斗星料号 SouthstarP/N 3.N204.0248

制作日期 Production date 2022-06-10

封样版本 Sample Version A 版

南斗星 (Southstar)		
编制 (FICTION)	品质 (DQE)	研发 (R&D)
客户 (Customer)		
采 购 (PUR)	品质 (QC)	研发 (R&D)

生产厂商：深圳市南斗星科技有限公司

深圳地址：深圳市宝安区西乡鹤州恒丰工业城 C6 栋 8. 10. 16 楼

东莞地址：东莞市虎门镇赤岗南坊一路三号

电 话：0755-27474071 传真：0755-29976316

网 址：WWW.SZ-SOUTHSTAR.COM

南斗星科技香港有限公司

SOUTH STAR TECHNOLOGY HONG KONG COMPANY LIMITED

承认书变更履历

版本	日期	变更描述	备注
Rev. 01	2022. 06. 10	初版	

目 录

Index

一、 封面 (Cover)	1
二、 版本记录	2
三、 目录 (Index)	3
四、 基本参数 (The basic parameters)	4
五、 工程图纸 (Product Drawing)	5
六、 测试设备 (Test Equipment & Conditions)	6
七、 性能测试报告 (Test Report)	7-8
八、 安装方式 (Installation method)	9
九、 包装方式 (Packing method)	10

南斗星科技香港有限公司

SOUTH STAR TECHNOLOGY HONG KONG COMPANY LIMITED

基本参数(The basic parameters)

A. Electrical Characteristics	
Frequency	2400MHZ~2500MHZ
VSWR	< 2
Avg Efficiency	>50%
Impedance	50 Ohm
Polarization	Linear
Peak Gain	2.4G:2.61dBi
B. Material & Mechanical Characteristics	
Material of Radiator	FPC black
Cable Type	∅ 1.13mm blue
Connector Type	
Dimension	
C. Environmental	
Operation Temperature	- 20 °C ~ + 60 °C
Storage Temperature	- 20 °C ~ + 80 °C

南斗星科技香港有限公司

SOUTH STAR TECHNOLOGY HONG KONG COMPANY LIMITED

测试设备(Test Equipment & Conditions)

- 1.网络分析仪Network Analyzers : Agilent 5071C
- 2.综合测试仪Communications Test Set: Agilent E5515C CMW500
- 3.3D暗室测试系统 3D Chamber Test System

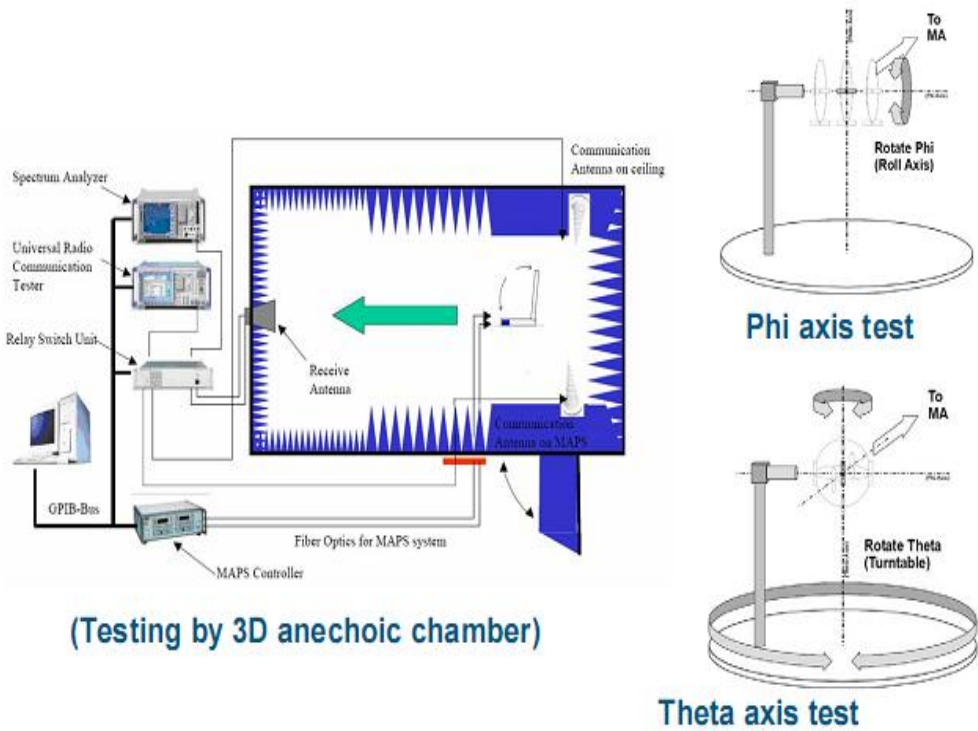

暗室规格: ETS-7 4 3

TD-SCDMA测试设备:StarPoint SP6010/Agilent 8960

LTE-TDD/FDD-SCDMA测试设备:StarPoint SP8011 /CMW500

WCDMA/GSM/CDMA测试设备: Agilent 8960

无源效率测试设备: Agilent Technologies E5071B

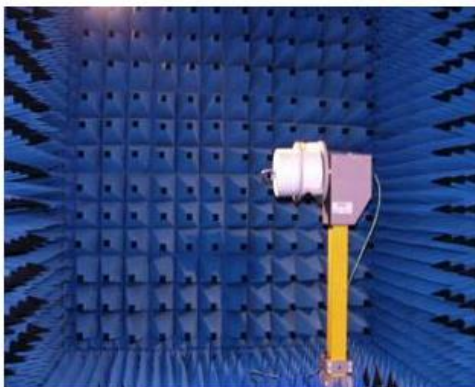

Antenna Impedance: S11 (parameter)

南斗星科技香港有限公司

SOUTH STAR TECHNOLOGY HONG KONG COMPANY LIMITED

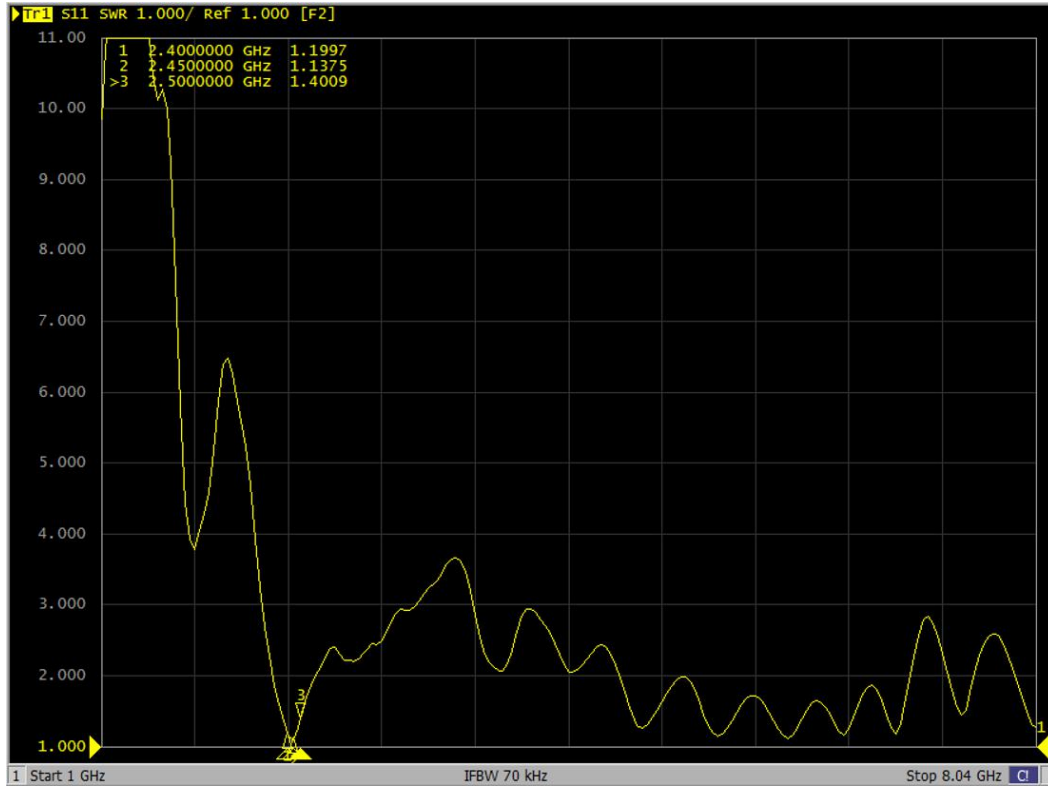

效率&增益(Efficiency & gain):

Passive Test For 2.4-BT		
Freq (MHz)	Effi (%)	Gain (dBi)
2400	53.46	2.17
2410	54.01	1.98
2420	54.65	1.68
2430	55.13	2.61
2440	55.65	2.51
2450	56.51	1.93
2460	56.49	2.29
2470	54.79	2.3
2480	56.73	2.57
2490	57.71	1.88
2500	54.48	2.15

南斗星科技香港有限公司

SOUTH STAR TECHNOLOGY HONG KONG COMPANY LIMITED

天线辐射图(Antenna radiation pattern):

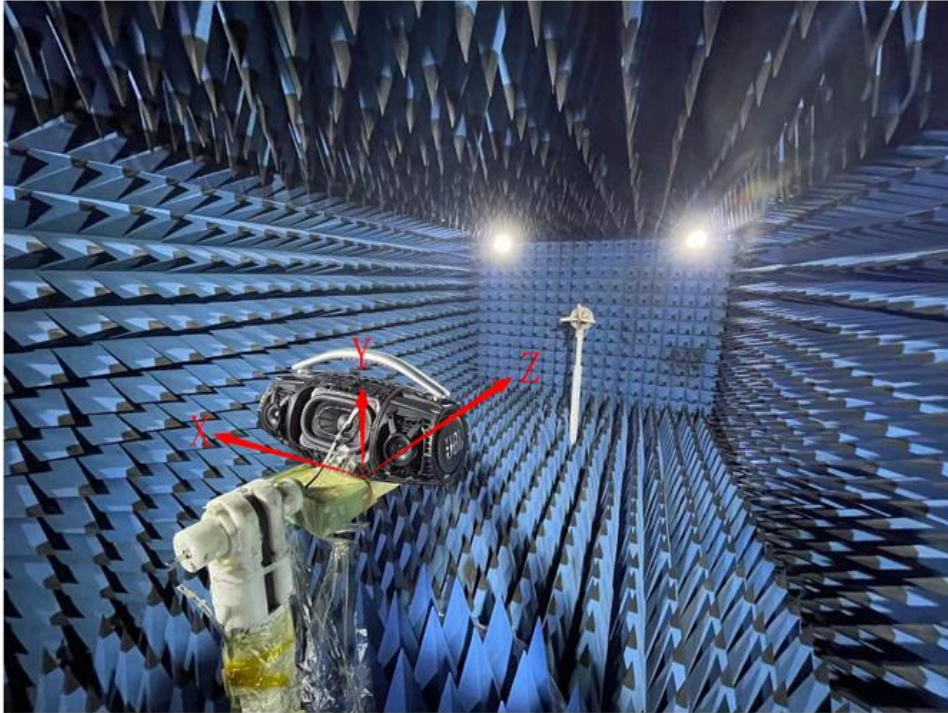

2450.000MHz

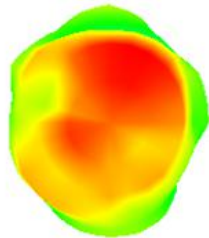

2450.000MHz H

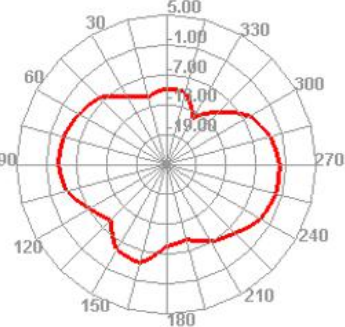

2450.000MHz E1

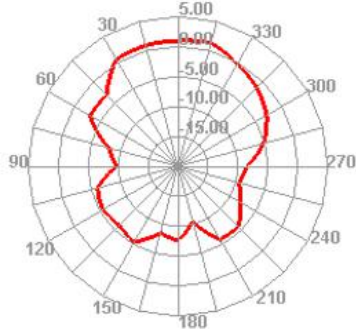

2450.000MHz E2

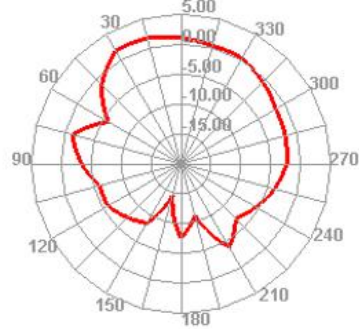

南斗星科技香港有限公司

SOUTH STAR TECHNOLOGY HONG KONG COMPANY LIMITED

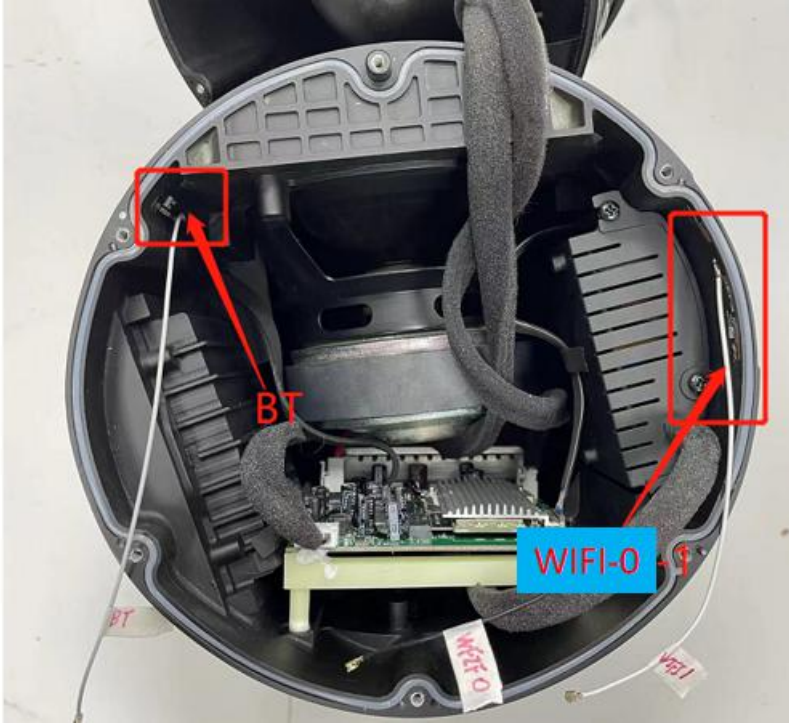

安装方式(Installation method):



南斗星科技香港有限公司

SOUTH STAR TECHNOLOGY HONG KONG COMPANY LIMITED

包装方式:

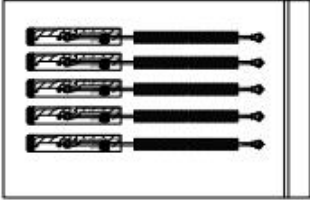
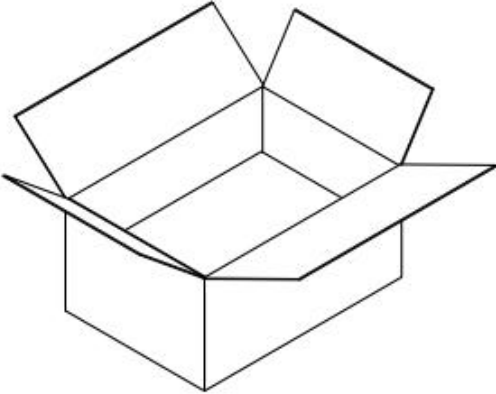
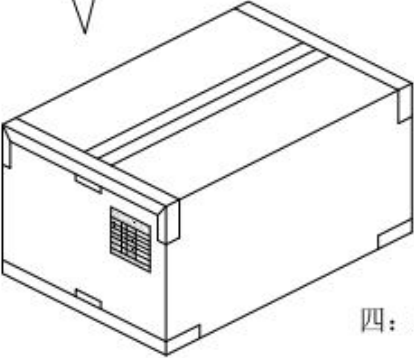
 South Star	<h2>产品包装规范</h2>	
日期: 2022-04-01	page: 1 of 1	
成品名称 : BOOMBOX3 PRO GG BT 天线	版本: A	
客户: 国光		
<p>一: 成品天线 </p> <p>二: 装袋, 每PE袋装50PCS产品, 端子使用珍珠棉包扎好。 </p> <p>三: 装箱, 每12袋装一箱, 一箱共600PCS产品(以实际包装为准)。 </p> <p>四: 封箱, 外箱贴我司生产标签和ROHS标签。 </p>		
批准: _____	确认: _____	拟制: 李森