

# 南斗星科技香港有限公司

SOUTH STAR TECHNOLOGY HONG KONG COMPANY LIMITED

## 承 认 书

### APPROVAL SHEET

样品封订

客户名称 Customer Name 悦辰

产品型号 Product Model C110

客户料号 Customer P/N \_\_\_\_\_

南斗星料号 SouthstarP/N 3. N204. 0216

制作日期 Production date 2022-02-18

封样版本 Sample Version A 版

南斗星 (Southstar)		
编制 (FICTION)	品质 (DQE)	研发 (R&D)
客户 (Customer)		
采 购 (PUR)	品质 (QC)	研发 (R&D)

生产厂商：深圳市南斗星科技有限公司

深圳地址：深圳市宝安区西乡鹤州恒丰工业城 C6 栋 8. 10. 16 楼

上海地址：上海市张江高科张衡路 198 弄 10 号楼 103B

电 话：0755-27474071 传真：0755-29976316

网 址：[WWW.SZ-SOUTHSTAR.COM](http://WWW.SZ-SOUTHSTAR.COM)



## 目 录

## Index

一、 封面 (Cover) .....	1
二、 版本记录 .....	2
三、 目录 (Index) .....	3
四、 基本参数 (The basic parameters) .....	4
五、 工程图纸 (Product Drawing) .....	5
六、 测试设备 (Test Equipment & Conditions) .....	6
七、 性能测试报告 (Test Report) .....	7-8
八、 安装方式 (Installation method) .....	9
九、 包装方式 (Packing method) .....	10

# 南斗星科技香港有限公司

SOUTH STAR TECHNOLOGY HONG KONG COMPANY LIMITED

## 基本参数(The basic parameters)

A. Electrical Characteristics	
<b>Frequency</b>	2400MHZ~2500MHZ 5150MHZ~5850MHZ 5925MHZ~7125MHZ
<b>VSWR</b>	< 2
<b>Avg Efficiency</b>	2.4G>50%    5.8G>50%    6G>50%
<b>Impedance</b>	50 Ohm
<b>Polarization</b>	Linear
<b>Peak Gain</b>	2.4G:2.12dBi    5.8G:3.14dBi    6G:4.25dBi
B. Material & Mechanical Characteristics	
<b>Material of Radiator</b>	FPC      black
<b>Cable Type</b>	∅ 1.13mm    white
<b>Connector Type</b>	一代端子
<b>Dimension</b>	
C. Environmental	
<b>Operation Temperature</b>	- 20 °C ~ + 60 °C
<b>Storage Temperature</b>	- 20 °C ~ + 80 °C

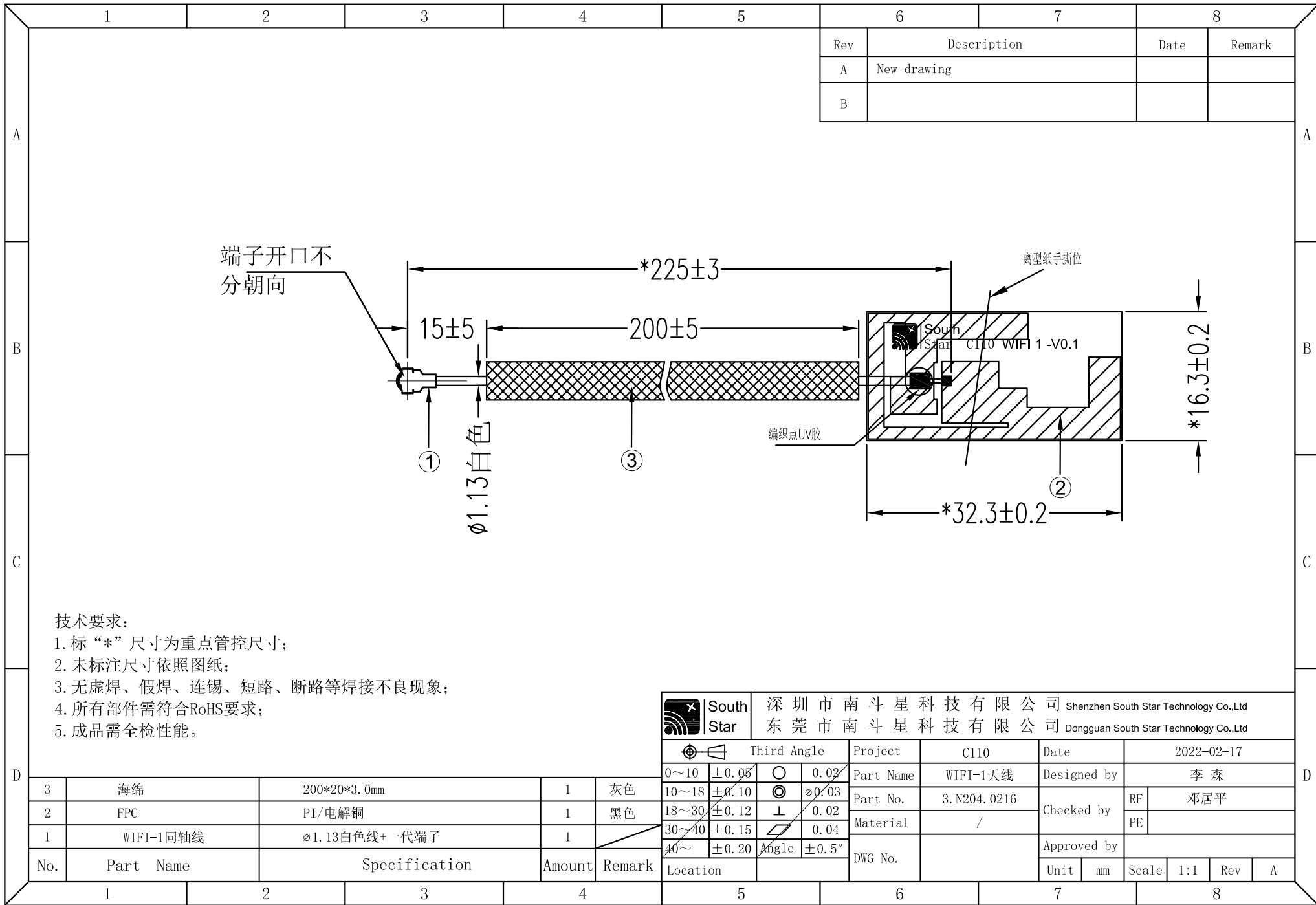

Rev	Description	Date	Remark
A	New drawing		
B			

技术要求:

1. 标“\*”尺寸为重点管控尺寸;
2. 未标注尺寸依照图纸;
3. 无虚焊、假焊、连锡、短路、断路等焊接不良现象;
4. 所有部件需符合RoHS要求;
5. 成品需全检性能。

	深圳市南斗星科技有限公司 Shenzhen South Star Technology Co.,Ltd 东莞市南斗星科技有限公司 Dongguan South Star Technology Co.,Ltd		Project		C110	Date		2022-02-17	
	第三角制 Third Angle 0~10 ±0.05 10~18 ±0.10 18~30 ±0.12 30~40 ±0.15 40~ ±0.20		公差 Tolerance 0.02 0.03 0.02 0.04 ±0.5°		Part Name	WIFI-1天线	Designed by		李森
				Part No.	3.N204.0216	Checked by		RF	邓居平
				Material	/	Approved by		PE	
				DWG No.		Unit	mm	Scale	1:1
				Location		Rev	A		

No.	Part Name	Specification	Amount	Remark
3	海绵	200*20*3.0mm	1	灰色
2	FPC	PI/电解铜	1	黑色
1	WIFI-1同轴线	∅1.13白色线+一代端子	1	

# 南斗星科技香港有限公司

SOUTH STAR TECHNOLOGY HONG KONG COMPANY LIMITED

## 测试设备(Test Equipment & Conditions)

### 1 测试仪器

VSWR 是使用安捷伦 E5071B 连接到制具来测试，状态为自由空间。

### 2 测试环境及方式

**暗室规格：ETS-7 4 3**

**TD-SCDMA测试设备:StarPoint SP6010/Agilent 8960**

**LTE-TDD/FDD-SCDMA测试设备:StarPoint SP8011 /CMW500**

**WCDMA/GSM/CDMA测试设备: Agilent 8960**

**无源效率测试设备: Agilent Technologies E5071B**

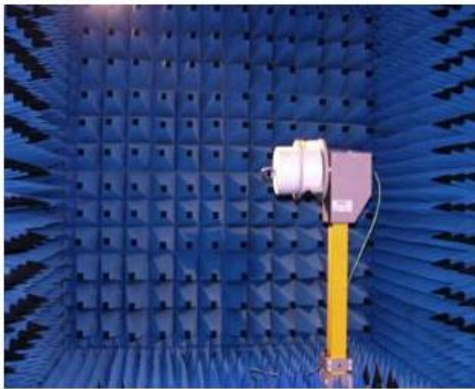

# 南斗星科技香港有限公司

SOUTH STAR TECHNOLOGY HONG KONG COMPANY LIMITED

Antenna Impedance: S11 (parameter)

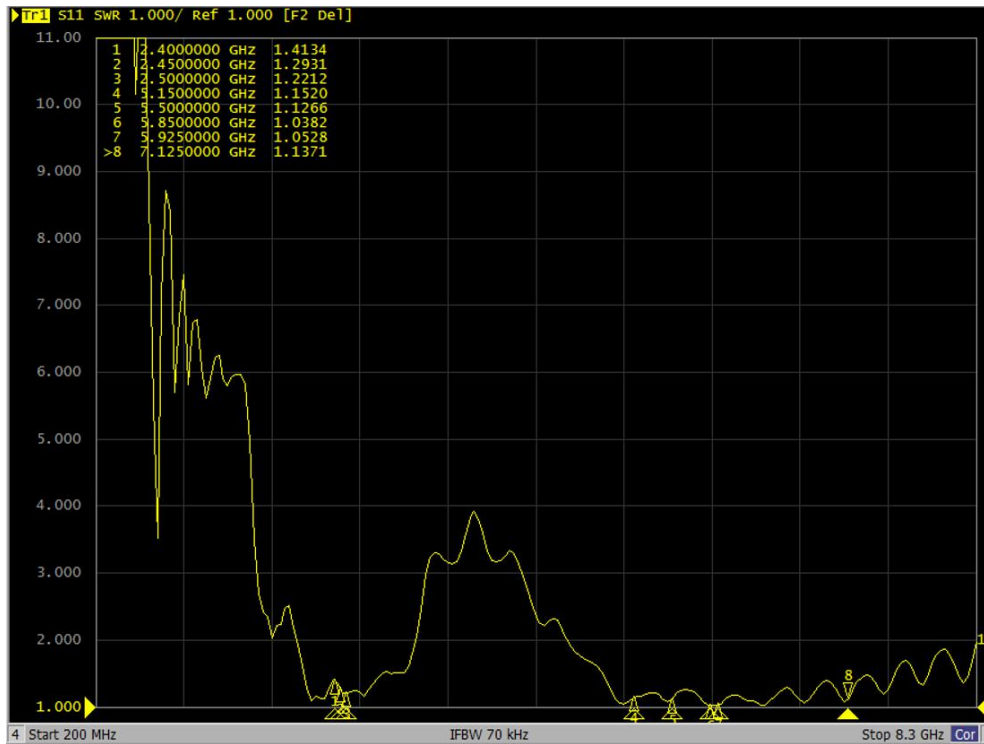

Freq (MHz)	2400	2450	2500	5150	5500	5850	5925	7125
VSWR	1.41	1.29	1.22	1.15	1.12	1.03	1.05	1.13

## 效率&增益(Efficiency & gain):

Passive Test For 2.4-WIFI		
Freq (MHz)	Effi (%)	Gain (dBi)
2400	53.86	1.73
2410	53.4	1.7
2420	53.39	1.99
2430	52.55	1.88
2440	50.44	1.74
2450	52.07	1.57
2460	51.32	1.95
2470	52.48	2.12
2480	53.9	2.3
2490	52.06	1.95
2500	52.24	1.98

Passive Test For 5G		
Freq (MHz)	Effi (%)	Gain (dBi)
5150	53.53	2.47
5200	55.17	2.57
5250	57.77	2.43
5300	54.26	2.81
5350	56.02	2.66
5400	59.49	2.11
5450	57.95	1.91
5500	57.57	1.94
5550	59.14	1.42
5600	56.67	2.92
5650	54.14	2.49
5700	53.89	2.23
5750	55.88	3.14
5800	56.94	2.84
5850	55.63	2.81

Passive Test For 6E		
Freq (MHz)	Effi (%)	Gain (dBi)
5900	54.22	4.07
5950	58.44	3.9
6000	56.3	3.67
6050	58.79	4.1
6100	59.16	3.98
6150	58.87	3.92
6200	54.52	3.34
6250	58.91	3.8
6300	52.1	3.38
6350	55.89	3.84
6400	52.8	4.14
6450	55.77	3.28
6500	56.61	3.94
6550	58.96	4.15
6600	55.47	4.25
6650	57.09	3.59
6700	52.73	3.73
6750	53.94	3.64
6800	58.18	3.87
6850	52.91	3.31
6900	56.4	3.63
6950	53.58	3.6
7000	55.29	3.45
7050	52.88	3.45
7100	56.35	4.2

# 南斗星科技香港有限公司

SOUTH STAR TECHNOLOGY HONG KONG COMPANY LIMITED

## 天线辐射图(Antenna radiation pattern):

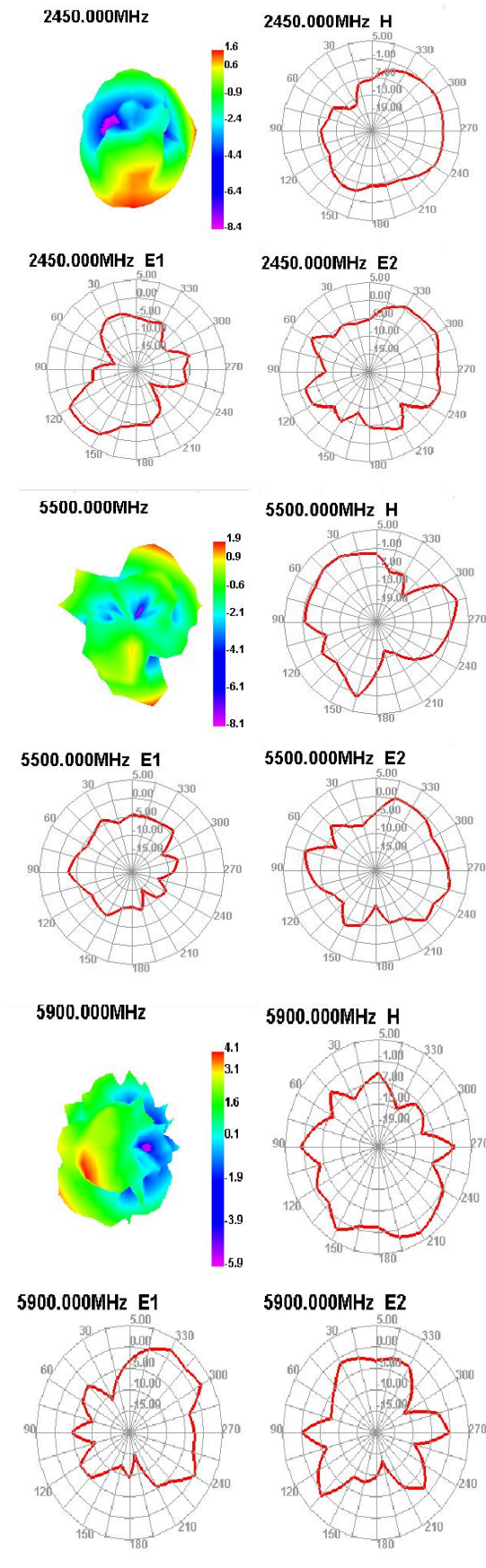



# 南斗星科技香港有限公司

SOUTH STAR TECHNOLOGY HONG KONG COMPANY LIMITED

安装方式(Installation method):

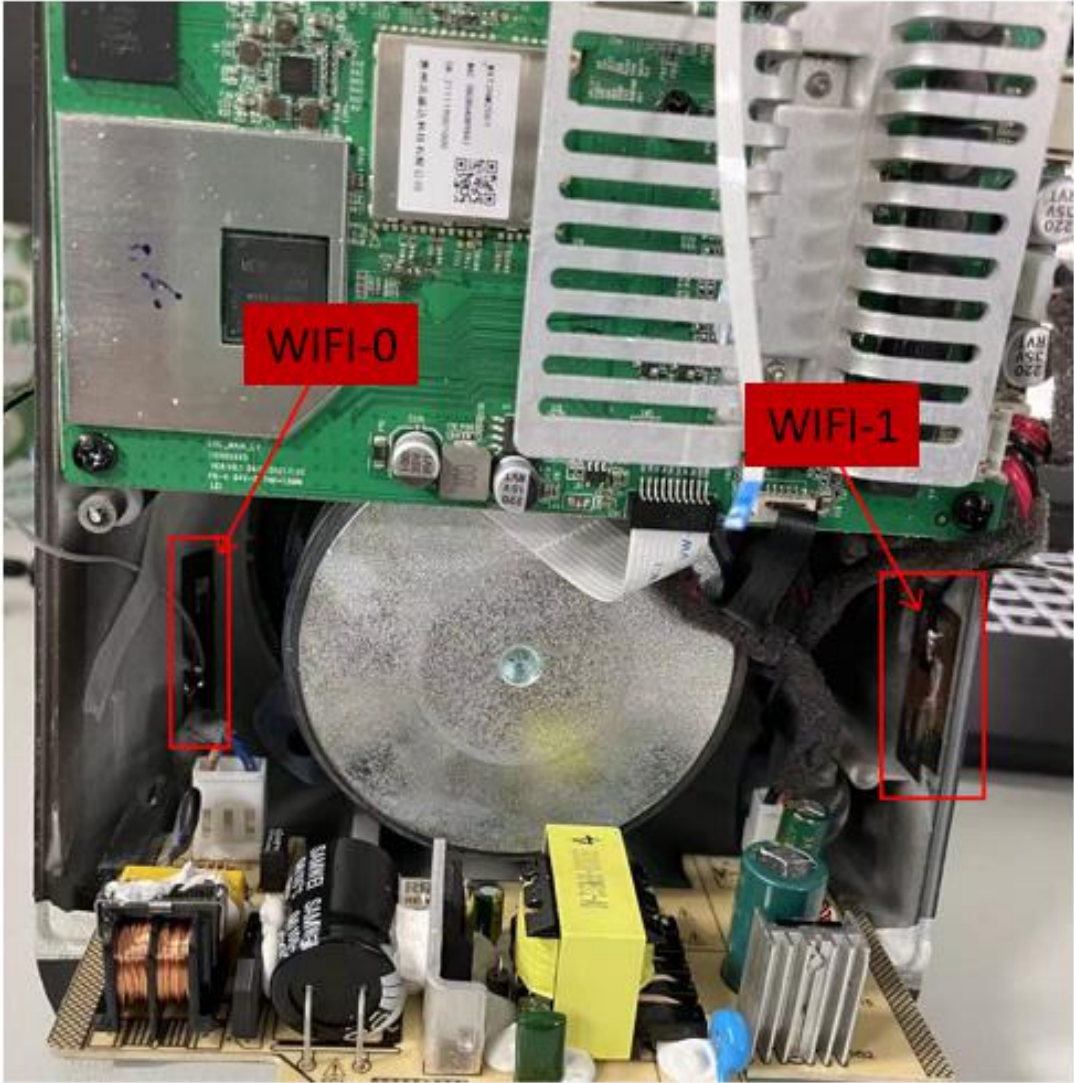

成品名称 : C110 WIFI-1天线	版本: A
	客户: 悦辰

一: 成品天线

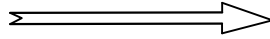

二: 装袋, 每PE袋装50PCS产品, 端子使用珍珠棉包扎好。

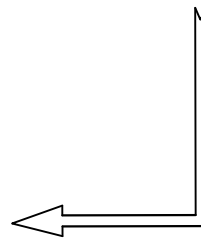
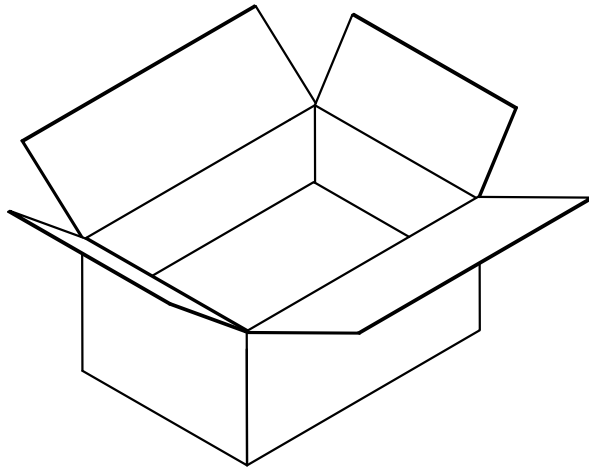
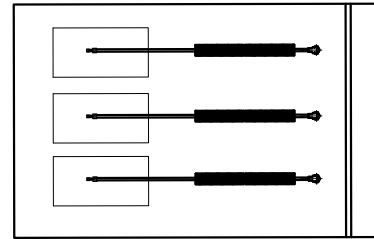

三: 装箱, 每12袋装一箱, 一箱共600PCS产品(以实际包装为准)。

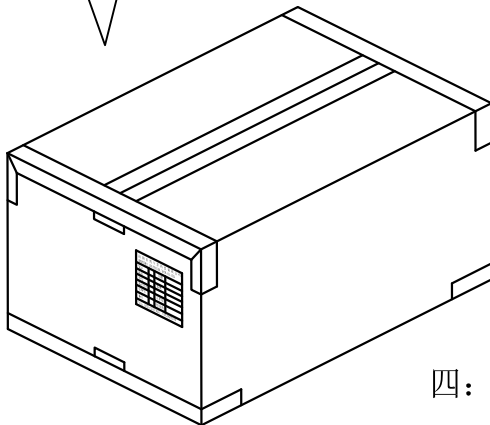
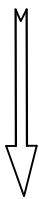

四: 封箱, 外箱贴我司生产标签和ROHS标签。

批准: \_\_\_\_\_

确认: \_\_\_\_\_

拟制: 李森