

# TR-4-E-009 Radiated Emission Test Result

**Test Site** : DDT 3m Chamber 3#

D:\E3 6.111\2022 Report Data\Q21123009-2E BAR500\FCC ABOVE 1G .EM6

**Test Date** : 2022-03-31

**Tested By** : Kensity Zhang

**EUT** : Multi-Channel Soundbar with wireless subwoofer

**Model Number** : BAR 500

**Power Supply** : AC 120V/60Hz

**Test Mode** : Tx mode

**Condition** : Temp:24.5°C,Humi:55%,Press:100.1kPa

**Antenna/Distance** : 2021 BBHA 9120D 3#/3m/VERTICAL

**Memo** : BLE 2M 2402

Data: 48

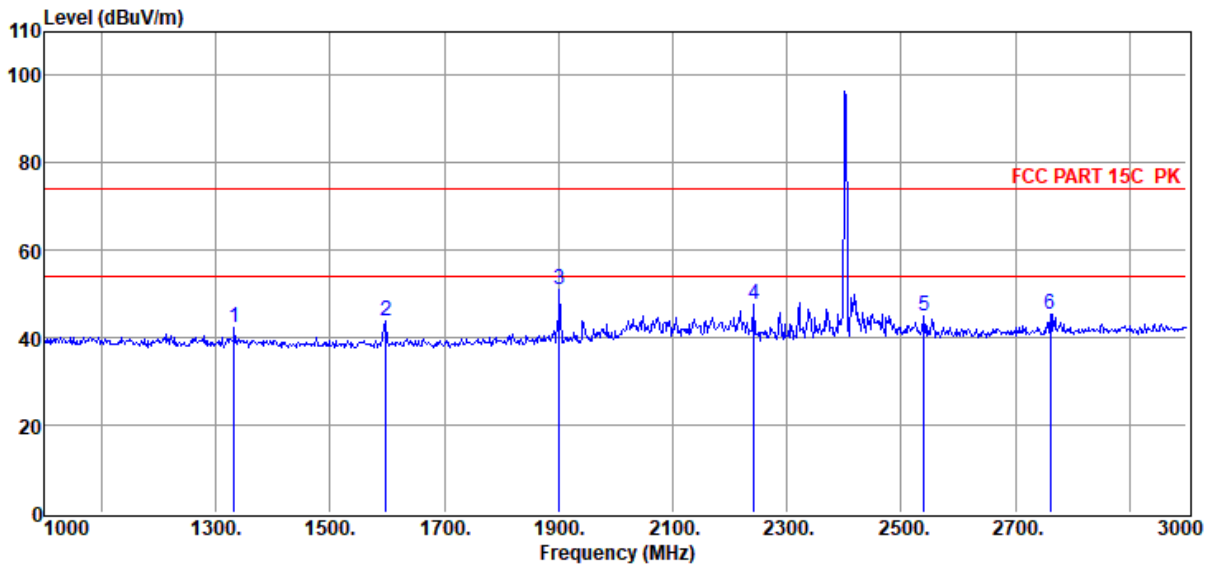

Item (Mark)	Freq. (MHz)	Read Level (dBμV)	Antenna Factor (dB/m)	PRM Factor dB	Cable Loss dB	Filter Factor dB	Result Level (dBμV/m)	Limit Line (dBμV/m)	Over Limit (dB)	Detector	Polarization
1	1332.00	53.50	25.43	38.40	1.29	0.56	42.38	74.00	-31.62	Peak	VERTICAL
2	1598.00	54.98	25.65	38.80	1.42	0.61	43.86	74.00	-30.14	Peak	VERTICAL
3	1902.00	61.72	26.45	39.25	1.56	0.66	51.14	74.00	-22.86	Peak	VERTICAL
4	2242.00	57.45	27.14	39.52	1.67	0.71	47.45	74.00	-26.55	Peak	VERTICAL
5	2540.00	54.47	27.75	39.67	1.75	0.74	45.04	74.00	-28.96	Peak	VERTICAL
6	2762.00	53.83	28.60	39.78	1.81	0.76	45.22	74.00	-28.78	Peak	VERTICAL

Note: 1. Result Level = Read Level + Antenna Factor + Cable loss + Filter Factor - PRM Factor.

2. If Peak Result complies with AV limit, AV Result is deemed to comply with AV limit.

3. Test setup: RBW: 1 MHz, VBW: 3 MHz, Sweep time: auto.

# TR-4-E-009 Radiated Emission Test Result

**Test Site** : DDT 3m Chamber 3#

D:\E3 6.111\2022 Report Data\Q21123009-2E BAR500\FCC ABOVE 1G .EM6

**Test Date** : 2022-03-31

**Tested By** : Kensity Zhang

**EUT** : Multi-Channel Soundbar with wireless subwoofer

**Model Number** : BAR 500

**Power Supply** : AC 120V/60Hz

**Test Mode** : Tx mode

**Condition** : Temp:24.5°C,Humi:55%,Press:100.1kPa

**Antenna/Distance** : 2021 BBHA 9120D 3#/3m/VERTICAL

**Memo** : BLE 2M 2440

Data: 49

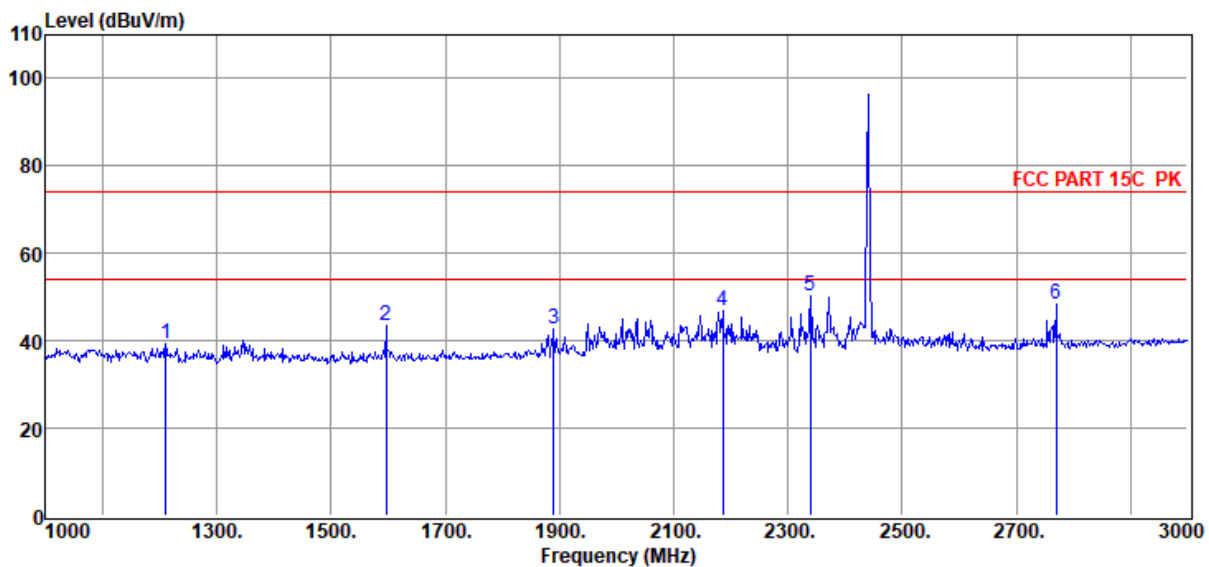

Item (Mark)	Freq. (MHz)	Read Level (dBμV)	Antenna Factor (dB/m)	PRM Factor dB	Cable Loss dB	Filter Factor dB	Result Level (dBμV/m)	Limit Line (dBμV/m)	Over Limit (dB)	Detector	Polarization
1	1210.00	50.35	25.46	38.22	1.22	0.54	39.35	74.00	-34.65	Peak	VERTICAL
2	1596.00	54.45	25.65	38.79	1.42	0.61	43.34	74.00	-30.66	Peak	VERTICAL
3	1890.00	53.34	26.41	39.24	1.55	0.66	42.72	74.00	-31.28	Peak	VERTICAL
4	2186.00	56.91	27.03	39.49	1.65	0.70	46.80	74.00	-27.20	Peak	VERTICAL
5	2340.00	60.20	27.31	39.57	1.70	0.72	50.36	74.00	-23.64	Peak	VERTICAL
6	2770.00	56.96	28.63	39.78	1.81	0.76	48.38	74.00	-25.62	Peak	VERTICAL

Note: 1. Result Level = Read Level + Antenna Factor + Cable loss + Filter Factor - PRM Factor.

2. If Peak Result complies with AV limit, AV Result is deemed to comply with AV limit.

3. Test setup: RBW: 1 MHz, VBW: 3 MHz, Sweep time: auto.

## TR-4-E-009 Radiated Emission Test Result

**Test Site** : DDT 3m Chamber 3#

D:\E3 6.111\2022 Report Data\Q21123009-2E BAR500\FCC ABOVE 1G .EM6

**Test Date** : 2022-03-31

**Tested By** : Kensity Zhang

**EUT** : Multi-Channel Soundbar with wireless subwoofer

**Model Number** : BAR 500

**Power Supply** : AC 120V/60Hz

**Test Mode** : Tx mode

**Condition** : Temp:24.5°C,Humi:55%,Press:100.1kPa

**Antenna/Distance** : 2021 BBHA 9120D  
3#/3m/HORIZONTAL

**Memo** : BLE 2M 2440

Data: 50

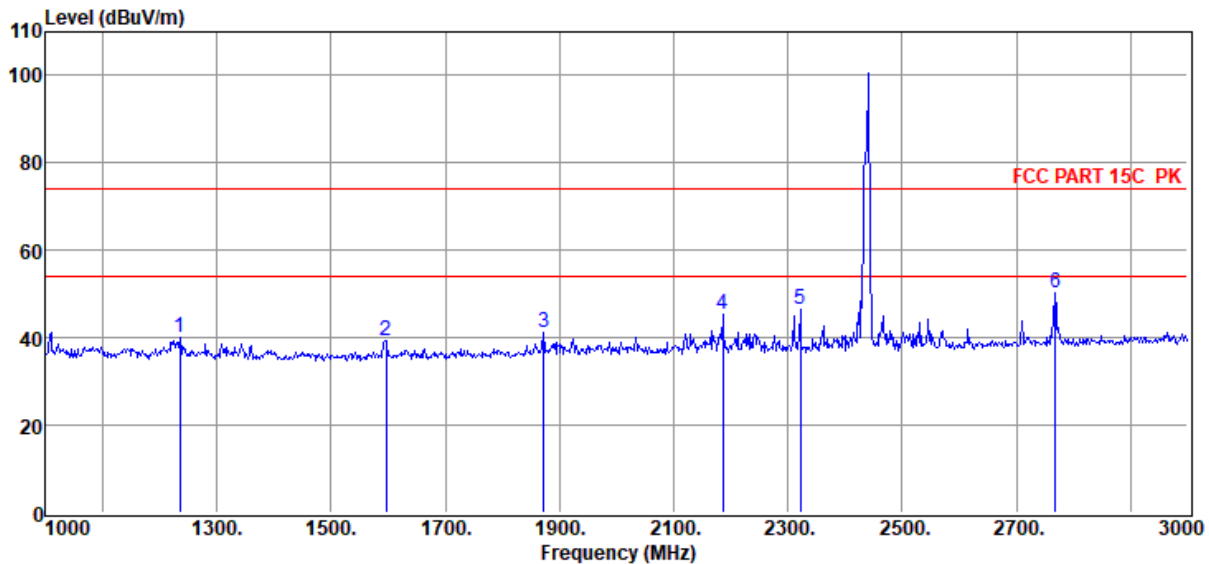

Item (Mark)	Freq. (MHz)	Read Level (dB $\mu$ V)	Antenna Factor (dB/m)	PRM Factor dB	Cable Loss dB	Filter Factor dB	Result Level (dB $\mu$ V/m)	Limit Line (dB $\mu$ V/m)	Over Limit (dB)	Detector	Polarization
1	1236.00	51.10	25.45	38.25	1.23	0.54	40.07	74.00	-33.93	Peak	HORIZONTAL
2	1596.00	50.52	25.65	38.79	1.42	0.61	39.41	74.00	-34.59	Peak	HORIZONTAL
3	1872.00	51.95	26.37	39.21	1.54	0.66	41.31	74.00	-32.69	Peak	HORIZONTAL
4	2186.00	55.55	27.03	39.49	1.65	0.70	45.44	74.00	-28.56	Peak	HORIZONTAL
5	2322.00	56.36	27.28	39.56	1.69	0.72	46.49	74.00	-27.51	Peak	HORIZONTAL
6	2768.00	58.94	28.62	39.78	1.81	0.76	50.35	74.00	-23.65	Peak	HORIZONTAL

Note: 1. Result Level = Read Level + Antenna Factor + Cable loss + Filter Factor - PRM Factor.

2. If Peak Result complies with AV limit, AV Result is deemed to comply with AV limit.

3. Test setup: RBW: 1 MHz, VBW: 3 MHz, Sweep time: auto.

## TR-4-E-009 Radiated Emission Test Result

**Test Site** : DDT 3m Chamber 3#

D:\E3 6.111\2022 Report Data\Q21123009-2E BAR500\FCC ABOVE 1G .EM6

**Test Date** : 2022-03-31

**Tested By** : Kensity Zhang

**EUT** : Multi-Channel Soundbar with wireless subwoofer

**Model Number** : BAR 500

**Power Supply** : AC 120V/60Hz

**Test Mode** : Tx mode

**Condition** : Temp:24.5°C,Humi:55%,Press:100.1kPa

**Antenna/Distance** : 2021 BBHA 9120D 3#/3m/VERTICAL

**Memo** : BLE 2M 2480

Data: 45

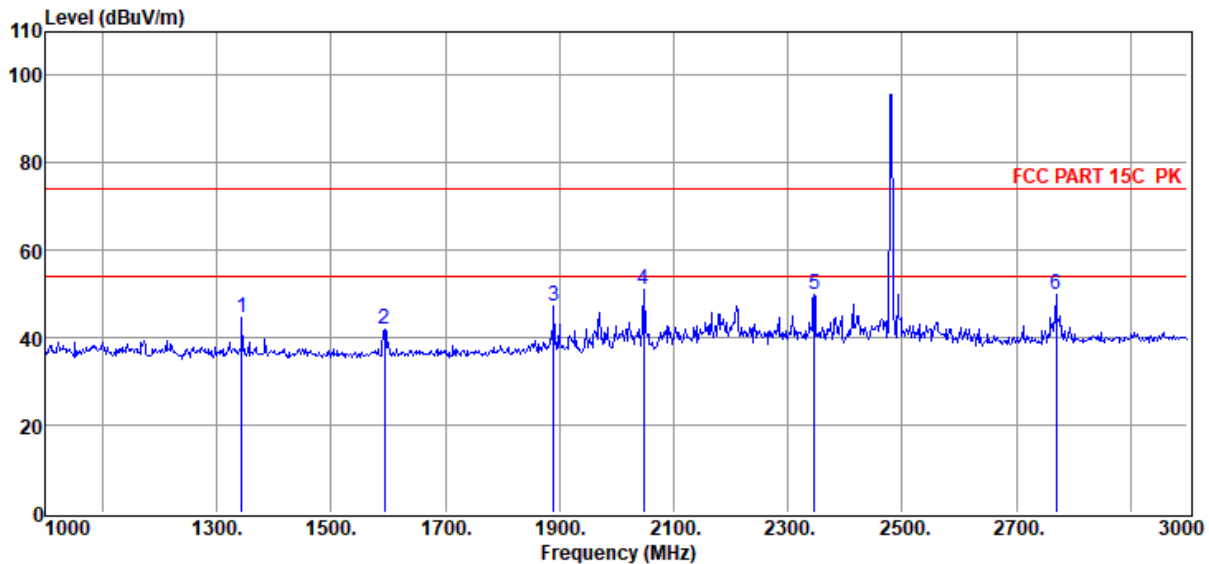

Item (Mark)	Freq. (MHz)	Read Level (dB $\mu$ V)	Antenna Factor (dB/m)	PRM Factor dB	Cable Loss dB	Filter Factor dB	Result Level (dB $\mu$ V/m)	Limit Line (dB $\mu$ V/m)	Over Limit (dB)	Detector	Polarization
1	1344.00	55.90	25.43	38.42	1.29	0.56	44.76	74.00	-29.24	Peak	VERTICAL
2	1594.00	53.03	25.64	38.79	1.42	0.61	41.91	74.00	-32.09	Peak	VERTICAL
3	1890.00	57.79	26.41	39.24	1.55	0.66	47.17	74.00	-26.83	Peak	VERTICAL
4	2048.00	61.27	26.79	39.42	1.61	0.69	50.94	74.00	-23.06	Peak	VERTICAL
5	2346.00	59.57	27.32	39.57	1.70	0.72	49.74	74.00	-24.26	Peak	VERTICAL
6	2770.00	58.36	28.63	39.78	1.81	0.76	49.78	74.00	-24.22	Peak	VERTICAL

Note: 1. Result Level = Read Level + Antenna Factor + Cable loss + Filter Factor - PRM Factor.

2. If Peak Result complies with AV limit, AV Result is deemed to comply with AV limit.

3. Test setup: RBW: 1 MHz, VBW: 3 MHz, Sweep time: auto.

# TR-4-E-009 Radiated Emission Test Result

**Test Site** : DDT 3m Chamber 3#

D:\E3 6.111\2022 Report Data\Q21123009-2E BAR500\FCC ABOVE 1G .EM6

**Test Date** : 2022-03-31

**Tested By** : Kensity Zhang

**EUT** : Multi-Channel Soundbar with wireless subwoofer

**Model Number** : BAR 500

**Power Supply** : AC 120V/60Hz

**Test Mode** : Tx mode

**Condition** : Temp:24.5°C,Humi:55%,Press:100.1kPa

**Antenna/Distance** : 2021 BBHA 9120D  
3#/3m/HORIZONTAL

**Memo** : BLE 2M 2480

Data: 46

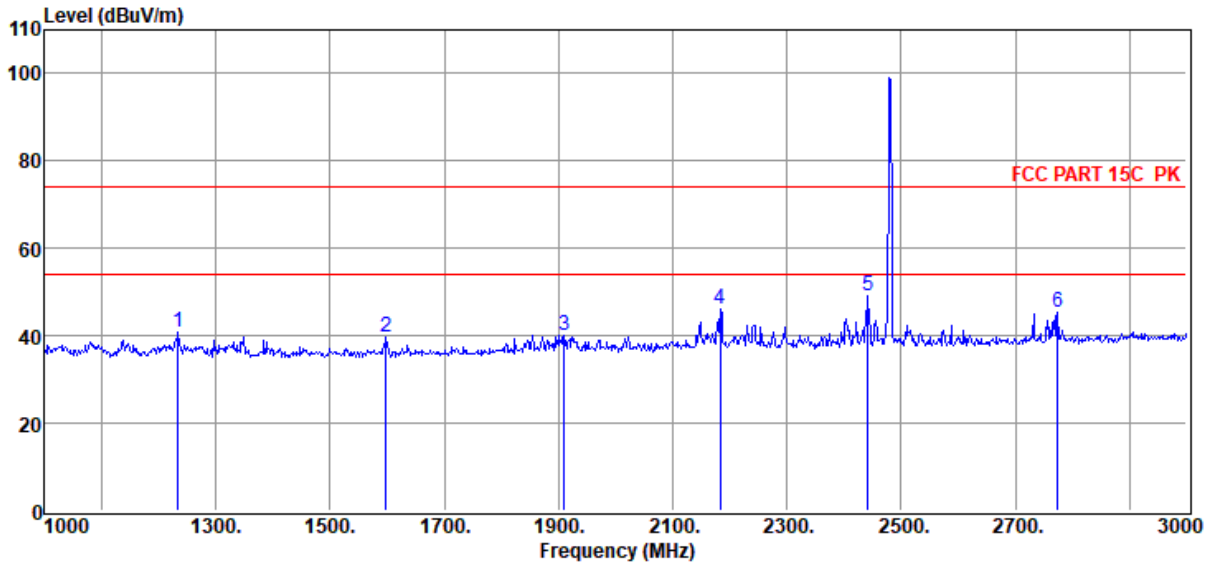

Item (Mark)	Freq. (MHz)	Read Level (dBuV)	Antenna Factor (dB/m)	PRM Factor (dB)	Cable Loss (dB)	Filter Factor (dB)	Result Level (dBuV/m)	Limit Line (dBuV/m)	Over Limit (dB)	Detector	Polarization
1	1234.00	51.94	25.45	38.25	1.23	0.54	40.91	74.00	-33.09	Peak	HORIZONTAL
2	1598.00	50.93	25.65	38.80	1.42	0.61	39.81	74.00	-34.19	Peak	HORIZONTAL
3	1910.00	50.73	26.47	39.27	1.56	0.66	40.15	74.00	-33.85	Peak	HORIZONTAL
4	2184.00	56.30	27.03	39.49	1.65	0.70	46.19	74.00	-27.81	Peak	HORIZONTAL
5	2442.00	58.66	27.50	39.62	1.72	0.73	48.99	74.00	-25.01	Peak	HORIZONTAL
6	2774.00	54.08	28.64	39.79	1.81	0.77	45.51	74.00	-28.49	Peak	HORIZONTAL

- Note: 1. Result Level = Read Level + Antenna Factor + Cable loss + Filter Factor - PRM Factor.  
 2. If Peak Result complies with AV limit, AV Result is deemed to comply with AV limit.  
 3. Test setup: RBW: 1 MHz, VBW: 3 MHz, Sweep time: auto.

# TR-4-E-009 Radiated Emission Test Result

**Test Site** : DDT 3m Chamber 3#

D:\E3 6.111\2022 Report Data\Q21123009-2E BAR500\FCC ABOVE 1G .EM6

**Test Date** : 2022-03-31

**Tested By** : Kensity Zhang

**EUT** : Multi-Channel Soundbar with wireless subwoofer

**Model Number** : BAR 500

**Power Supply** : AC 120V/60Hz

**Test Mode** : Tx mode

**Condition** : Temp:24.5°C,Humi:55%,Press:100.1kPa

**Antenna/Distance** : 2021 BBHA 9120D 3#/3m/VERTICAL

**Memo** : BLE 2M 2402

Data: 51

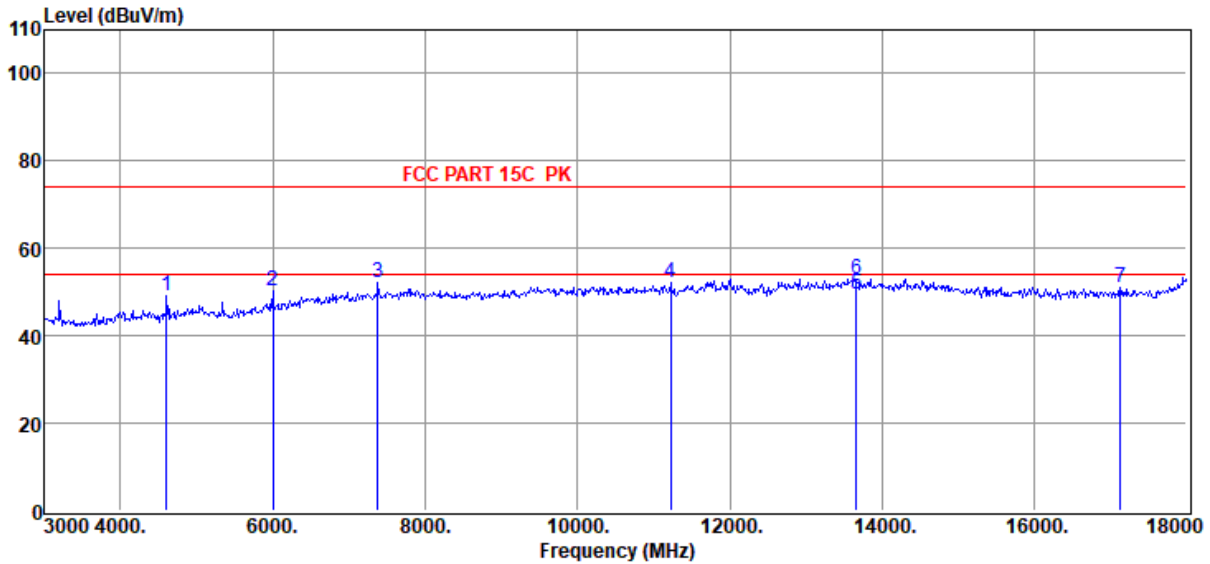

Item (Mark)	Freq. (MHz)	Read Level (dBμV)	Antenna Factor (dB/m)	PRM Factor (dB)	Cable Loss (dB)	Filter Factor (dB)	Result Level (dBμV/m)	Limit Line (dBμV/m)	Over Limit (dB)	Detector	Polarization
1	4605.00	53.15	31.84	40.32	2.40	2.13	49.20	74.00	-24.80	Peak	VERTICAL
2	6000.00	50.96	34.00	40.50	3.03	2.80	50.29	74.00	-23.71	Peak	VERTICAL
3	7380.00	50.39	36.30	39.74	3.11	2.27	52.33	74.00	-21.67	Peak	VERTICAL
4	11220.00	47.09	39.17	40.18	3.87	2.38	52.33	74.00	-21.67	Peak	VERTICAL
5	13665.00	42.38	39.97	39.93	4.17	2.92	49.51	54.00	-4.49	Average	VERTICAL
6	13665.00	45.93	39.97	39.93	4.17	2.92	53.06	74.00	-20.94	Peak	VERTICAL
7	17130.00	44.21	38.73	40.18	4.74	3.55	51.05	74.00	-22.95	Peak	VERTICAL

- Note: 1. Result Level = Read Level + Antenna Factor + Cable loss + Filter Factor - PRM Factor.  
 2. If Peak Result complies with AV limit, AV Result is deemed to comply with AV limit.  
 3. Test setup: RBW: 1 MHz, VBW: 3 MHz, Sweep time: auto.



# TR-4-E-009 Radiated Emission Test Result

**Test Site** : DDT 3m Chamber 3#

D:\E3 6.111\2022 Report Data\Q21123009-2E BAR500\FCC ABOVE 1G .EM6

**Test Date** : 2022-03-31

**Tested By** : Kensity Zhang

**EUT** : Multi-Channel Soundbar with wireless subwoofer

**Model Number** : BAR 500

**Power Supply** : AC 120V/60Hz

**Test Mode** : Tx mode

**Condition** : Temp:24.5°C,Humi:55%,Press:100.1kPa

**Antenna/Distance** : 2021 BBHA 9120D  
3#/3m/HORIZONTAL

**Memo** : BLE 2M 2402

Data: 52

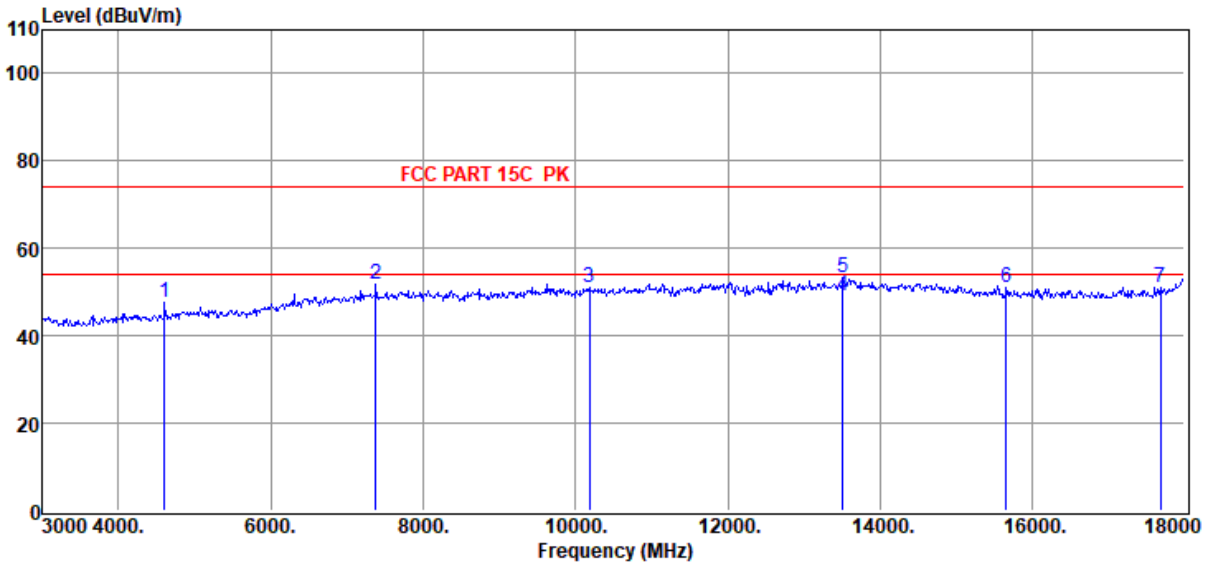

Item (Mark)	Freq. (MHz)	Read Level (dBμV)	Antenna Factor (dB/m)	PRM Factor (dB)	Cable Loss (dB)	Filter Factor (dB)	Result Level (dBμV/m)	Limit Line (dBμV/m)	Over Limit (dB)	Detector	Polarization
1	4605.00	51.69	31.84	40.32	2.40	2.13	47.74	74.00	-26.26	Peak	HORIZONTAL
2	7380.00	50.01	36.30	39.74	3.11	2.27	51.95	74.00	-22.05	Peak	HORIZONTAL
3	10185.00	46.95	38.62	40.53	3.67	2.46	51.17	74.00	-22.83	Peak	HORIZONTAL
4	13515.00	42.10	40.00	40.04	4.01	2.93	49.00	54.00	-5.00	Average	HORIZONTAL
5	13515.00	46.49	40.00	40.04	4.01	2.93	53.39	74.00	-20.61	Peak	HORIZONTAL
6	15660.00	44.64	38.51	39.80	4.57	2.95	50.87	74.00	-23.13	Peak	HORIZONTAL
7	17685.00	42.50	40.55	40.51	4.87	3.70	51.11	74.00	-22.89	Peak	HORIZONTAL

- Note: 1. Result Level = Read Level + Antenna Factor + Cable loss + Filter Factor - PRM Factor.  
 2. If Peak Result complies with AV limit, AV Result is deemed to comply with AV limit.  
 3. Test setup: RBW: 1 MHz, VBW: 3 MHz, Sweep time: auto.

## TR-4-E-009 Radiated Emission Test Result

**Test Site** : DDT 3m Chamber 3#

D:\E3 6.111\2022 Report Data\Q21123009-2E BAR500\FCC ABOVE 1G .EM6

**Test Date** : 2022-03-31

**Tested By** : Kensity Zhang

**EUT** : Multi-Channel Soundbar with wireless subwoofer

**Model Number** : BAR 500

**Power Supply** : AC 120V/60Hz

**Test Mode** : Tx mode

**Condition** : Temp:24.5°C,Humi:55%,Press:100.1kPa

**Antenna/Distance** : 2021 BBHA 9120D  
3#/3m/HORIZONTAL

**Memo** : BLE 2M 2440

Data: 53

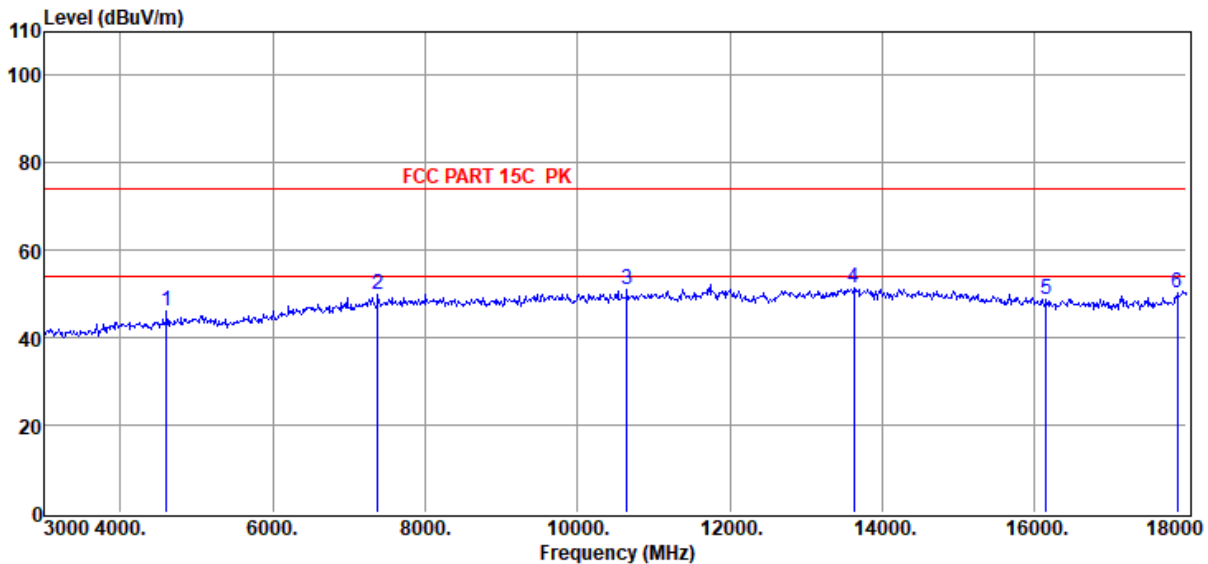

Item (Mark)	Freq. (MHz)	Read Level (dB $\mu$ V)	Antenna Factor (dB/m)	PRM Factor dB	Cable Loss dB	Filter Factor dB	Result Level (dB $\mu$ V/m)	Limit Line (dB $\mu$ V/m)	Over Limit (dB)	Detector	Polarization
1	4605.00	51.24	31.84	40.32	2.40	0.89	46.05	74.00	-27.95	Peak	HORIZONTAL
2	7380.00	49.27	36.30	39.74	3.11	1.02	49.96	74.00	-24.04	Peak	HORIZONTAL
3	10650.00	47.00	39.09	40.34	3.71	1.38	50.84	74.00	-23.16	Peak	HORIZONTAL
4	13635.00	45.61	39.97	39.96	4.14	1.47	51.23	74.00	-22.77	Peak	HORIZONTAL
5	16155.00	44.38	37.90	39.93	4.64	1.70	48.69	74.00	-25.31	Peak	HORIZONTAL
6	17880.00	42.51	41.76	40.63	4.93	1.80	50.37	74.00	-23.63	Peak	HORIZONTAL

Note: 1. Result Level = Read Level + Antenna Factor + Cable loss + Filter Factor - PRM Factor.

2. If Peak Result complies with AV limit, AV Result is deemed to comply with AV limit.

3. Test setup: RBW: 1 MHz, VBW: 3 MHz, Sweep time: auto.



# TR-4-E-009 Radiated Emission Test Result

**Test Site** : DDT 3m Chamber 3#

D:\E3 6.111\2022 Report Data\Q21123009-2E BAR500\FCC ABOVE 1G .EM6

**Test Date** : 2022-03-31

**Tested By** : Kensity Zhang

**EUT** : Multi-Channel Soundbar with wireless subwoofer

**Model Number** : BAR 500

**Power Supply** : AC 120V/60Hz

**Test Mode** : Tx mode

**Condition** : Temp:24.5°C,Humi:55%,Press:100.1kPa

**Antenna/Distance** : 2021 BBHA 9120D 3#/3m/VERTICAL

**Memo** : BLE 2M 2440

Data: 54

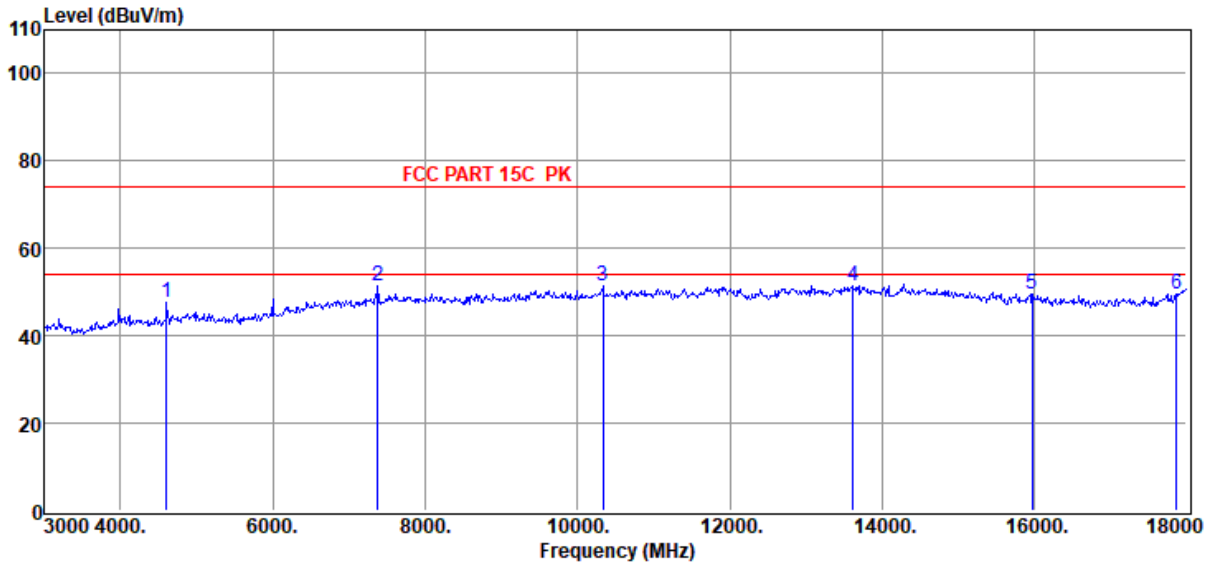

Item (Mark)	Freq. (MHz)	Read Level (dBuV)	Antenna Factor (dB/m)	PRM Factor (dB)	Cable Loss (dB)	Filter Factor (dB)	Result Level (dBuV/m)	Limit Line (dBuV/m)	Over Limit (dB)	Detector	Polarization
1	4605.00	52.86	31.84	40.32	2.40	0.89	47.67	74.00	-26.33	Peak	VERTICAL
2	7380.00	50.80	36.30	39.74	3.11	1.02	51.49	74.00	-22.51	Peak	VERTICAL
3	10335.00	47.86	38.80	40.47	3.67	1.37	51.23	74.00	-22.77	Peak	VERTICAL
4	13620.00	45.99	39.98	39.97	4.12	1.47	51.59	74.00	-22.41	Peak	VERTICAL
5	15975.00	45.26	37.94	39.89	4.60	1.70	49.61	74.00	-24.39	Peak	VERTICAL
6	17865.00	41.67	41.66	40.62	4.92	1.80	49.43	74.00	-24.57	Peak	VERTICAL

- Note: 1. Result Level = Read Level + Antenna Factor + Cable loss + Filter Factor - PRM Factor.  
 2. If Peak Result complies with AV limit, AV Result is deemed to comply with AV limit.  
 3. Test setup: RBW: 1 MHz, VBW: 3 MHz, Sweep time: auto.

## TR-4-E-009 Radiated Emission Test Result

**Test Site** : DDT 3m Chamber 3#

D:\E3 6.111\2022 Report Data\Q21123009-2E BAR500\FCC ABOVE 1G .EM6

**Test Date** : 2022-03-31

**Tested By** : Kensity Zhang

**EUT** : Multi-Channel Soundbar with wireless subwoofer

**Model Number** : BAR 500

**Power Supply** : AC 120V/60Hz

**Test Mode** : Tx mode

**Condition** : Temp:24.5°C,Humi:55%,Press:100.1kPa

**Antenna/Distance** : 2021 BBHA 9120D 3#/3m/VERTICAL

**Memo** : BLE 2M 2480

Data: 55

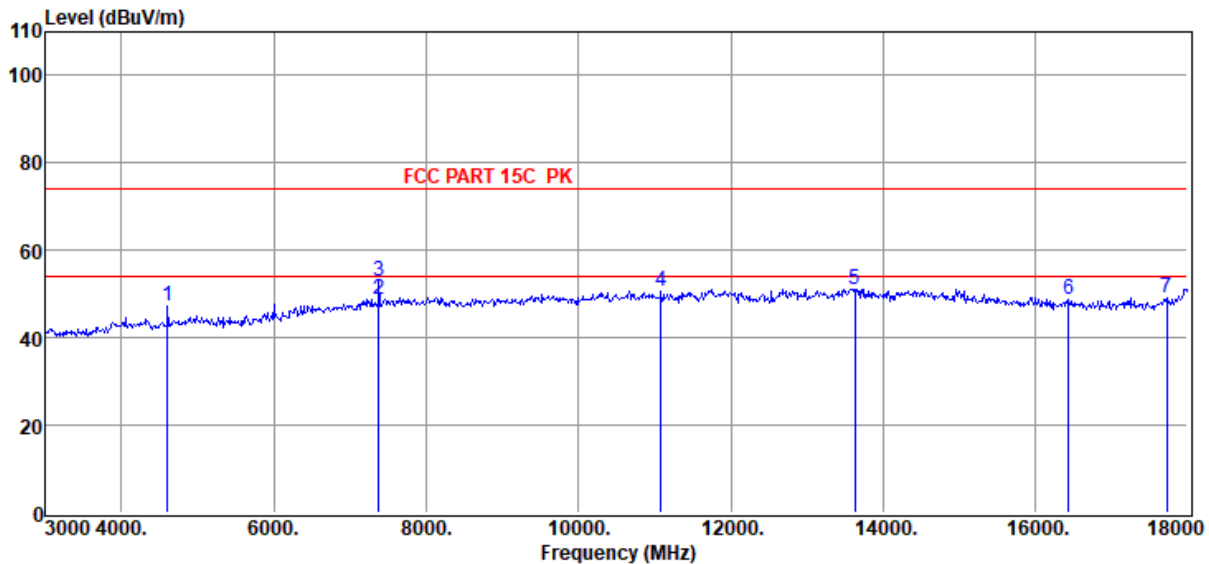

Item (Mark)	Freq. (MHz)	Read Level (dB $\mu$ V)	Antenna Factor (dB/m)	PRM Factor dB	Cable Loss dB	Filter Factor dB	Result Level (dB $\mu$ V/m)	Limit Line (dB $\mu$ V/m)	Over Limit (dB)	Detector	Polarization
1	4605.00	52.34	31.84	40.32	2.40	0.89	47.15	74.00	-26.85	Peak	VERTICAL
2	7380.00	48.13	36.30	39.74	3.11	1.02	48.82	54.00	-5.18	Average	VERTICAL
3	7380.00	52.06	36.30	39.74	3.11	1.02	52.75	74.00	-21.25	Peak	VERTICAL
4	11085.00	46.46	39.25	40.19	3.83	1.37	50.72	74.00	-23.28	Peak	VERTICAL
5	13635.00	45.53	39.97	39.96	4.14	1.47	51.15	74.00	-22.85	Peak	VERTICAL
6	16440.00	44.41	37.90	39.99	4.71	1.69	48.72	74.00	-25.28	Peak	VERTICAL
7	17730.00	42.37	40.83	40.54	4.88	1.78	49.32	74.00	-24.68	Peak	VERTICAL

Note: 1. Result Level = Read Level + Antenna Factor + Cable loss + Filter Factor - PRM Factor.

2. If Peak Result complies with AV limit, AV Result is deemed to comply with AV limit.

3. Test setup: RBW: 1 MHz, VBW: 3 MHz, Sweep time: auto.

## TR-4-E-009 Radiated Emission Test Result

**Test Site** : DDT 3m Chamber 3#

D:\E3 6.111\2022 Report Data\Q21123009-2E BAR500\FCC ABOVE 1G .EM6

**Test Date** : 2022-03-31

**Tested By** : Kennsy Zhang

**EUT** : Multi-Channel Soundbar with wireless subwoofer

**Model Number** : BAR 500

**Power Supply** : AC 120V/60Hz

**Test Mode** : Tx mode

**Condition** : Temp:24.5°C,Humi:55%,Press:100.1kPa

**Antenna/Distance** : 2021 BBHA 9120D  
3#/3m/HORIZONTAL

**Memo** : BLE 2M 2480

Data: 56

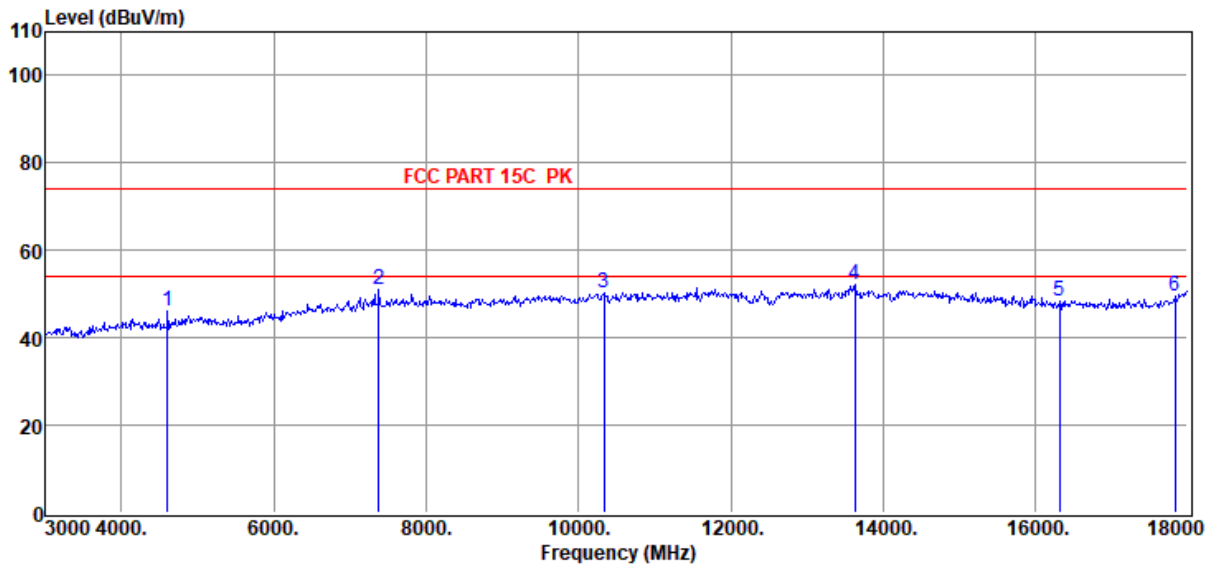

Item (Mark)	Freq. (MHz)	Read Level (dB $\mu$ V)	Antenna Factor (dB/m)	PRM Factor dB	Cable Loss dB	Filter Factor dB	Result Level (dB $\mu$ V/m)	Limit Line (dB $\mu$ V/m)	Over Limit (dB)	Detector	Polarization
1	4605.00	51.18	31.84	40.32	2.40	0.89	45.99	74.00	-28.01	Peak	HORIZONTAL
2	7380.00	50.26	36.30	39.74	3.11	1.02	50.95	74.00	-23.05	Peak	HORIZONTAL
3	10335.00	46.86	38.80	40.47	3.67	1.37	50.23	74.00	-23.77	Peak	HORIZONTAL
4	13635.00	46.65	39.97	39.96	4.14	1.47	52.27	74.00	-21.73	Peak	HORIZONTAL
5	16320.00	44.22	37.90	39.96	4.68	1.70	48.54	74.00	-25.46	Peak	HORIZONTAL
6	17835.00	42.00	41.48	40.60	4.91	1.80	49.59	74.00	-24.41	Peak	HORIZONTAL

Note: 1. Result Level = Read Level + Antenna Factor + Cable loss + Filter Factor - PRM Factor.

2. If Peak Result complies with AV limit, AV Result is deemed to comply with AV limit.

3. Test setup: RBW: 1 MHz, VBW: 3 MHz, Sweep time: auto.

## 9. RF Conducted Spurious Emissions

### 9.1. Block diagram of test setup

Same as section 4.1

### 9.2. Limits

In any 100 kHz bandwidth outside the frequency bands in which the spread spectrum intentional radiator is operating, the radio frequency power that is produced by the intentional radiator shall be at least 20 dB below that in the 100 kHz bandwidth within the band that contains the highest level of the desired power.

### 9.3. Test procedure

(1) Connect EUT's antenna output to spectrum analyzer by RF cable.

(2) Establish a reference level by using the following procedure:

Center frequency	Test frequency
RBW:	100 kHz
VBW:	300 kHz
Span	Wide enough to capture the peak level of the in-band emission
Detector Mode:	Peak
Sweep time:	auto
Trace mode	Max hold

(3) Allow the trace to stabilize, use the peak marker function to determine the maximum peak power level to establish the reference level.

(4) Set the spectrum analyzer as follows:

RBW:	100 kHz
VBW:	300 kHz
Span	Encompass frequency range to be measured
Number of measurement points	$\geq \text{span}/\text{RBW}$
Detector Mode:	Peak
Sweep time:	auto
Trace mode	Max hold

(5) Allow the trace to stabilize, use the peak marker function to determine the maximum amplitude of all unwanted emissions outside of the authorized frequency band

### 9.4. Test result

Mode	Freq. (MHz)	Verdict
GFSK 1M	2402	Pass
	2440	Pass
	2480	Pass
GFSK 2M	2402	Pass
	2440	Pass
	2480	Pass

### 9.5. Original test data

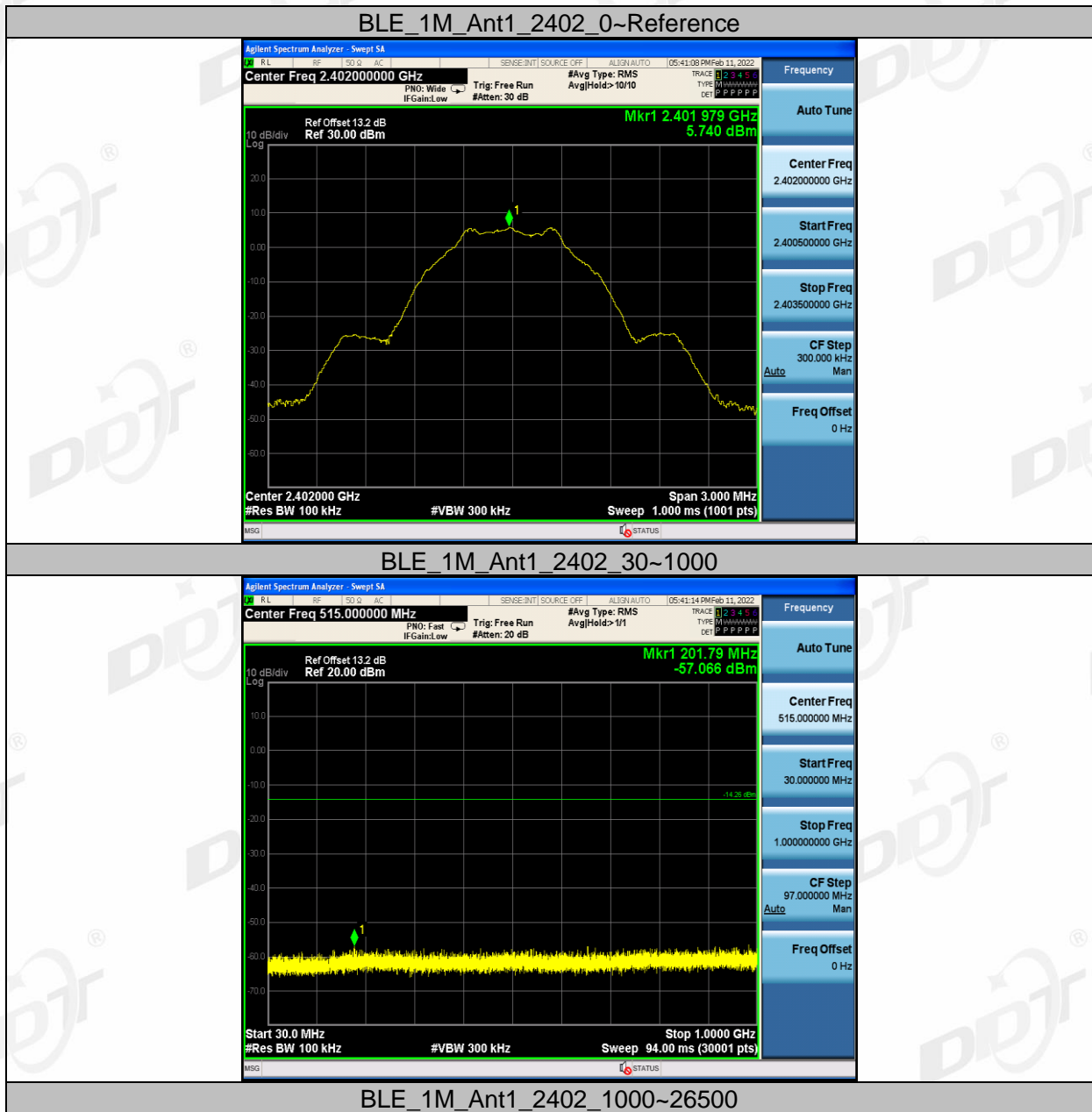



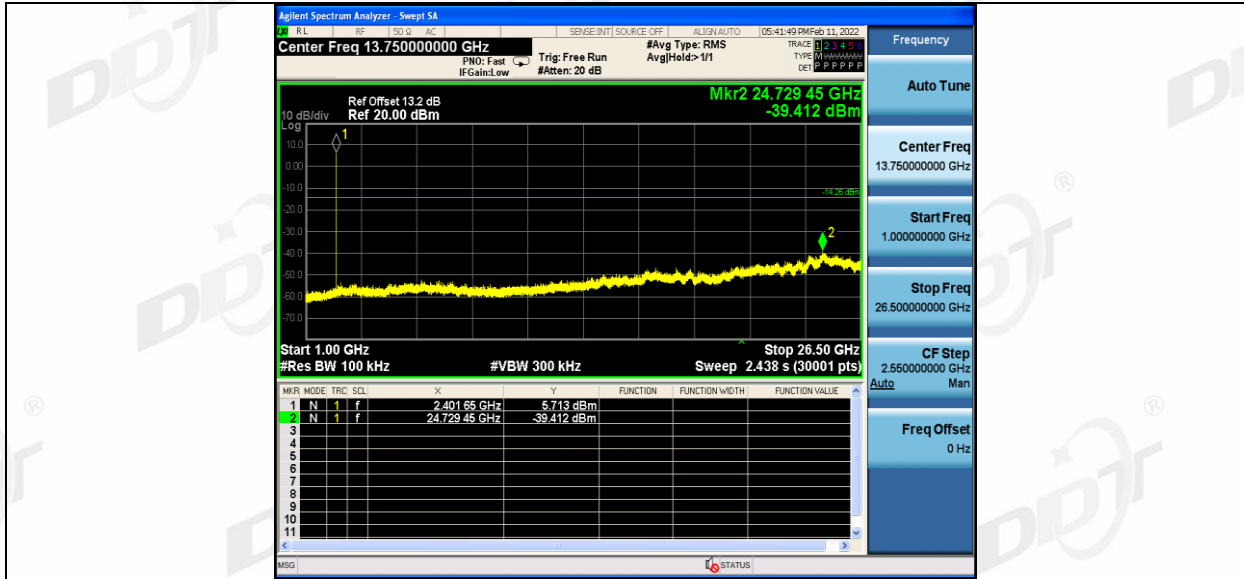

BLE\_1M\_Ant1\_2440\_0~Reference



BLE\_1M\_Ant1\_2440\_30~1000

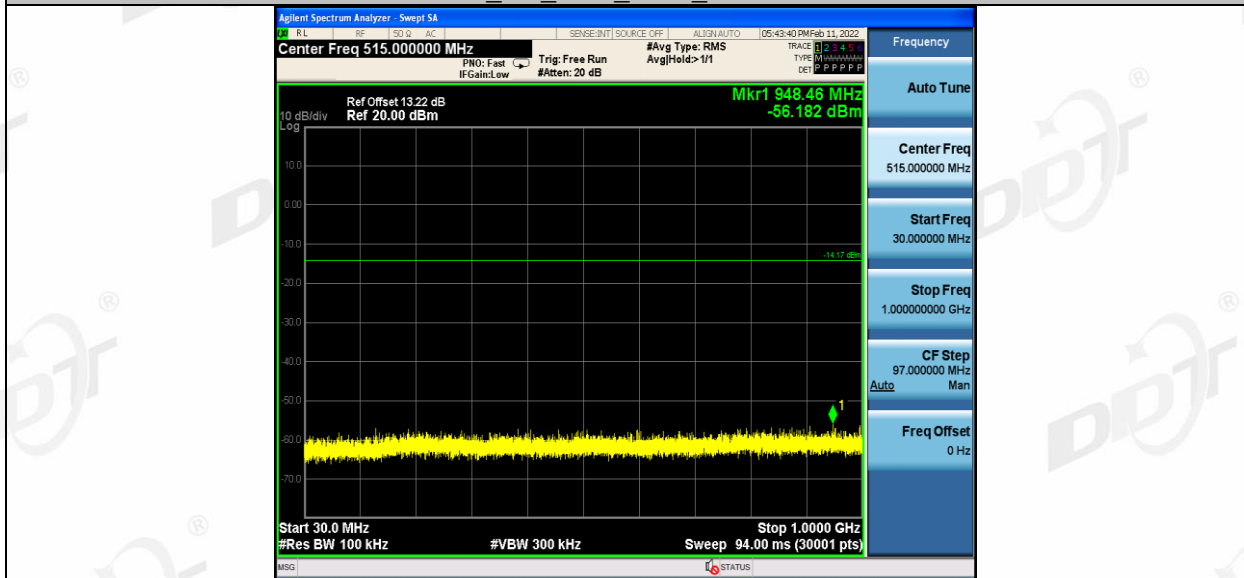

BLE\_1M\_Ant1\_2440\_1000~26500



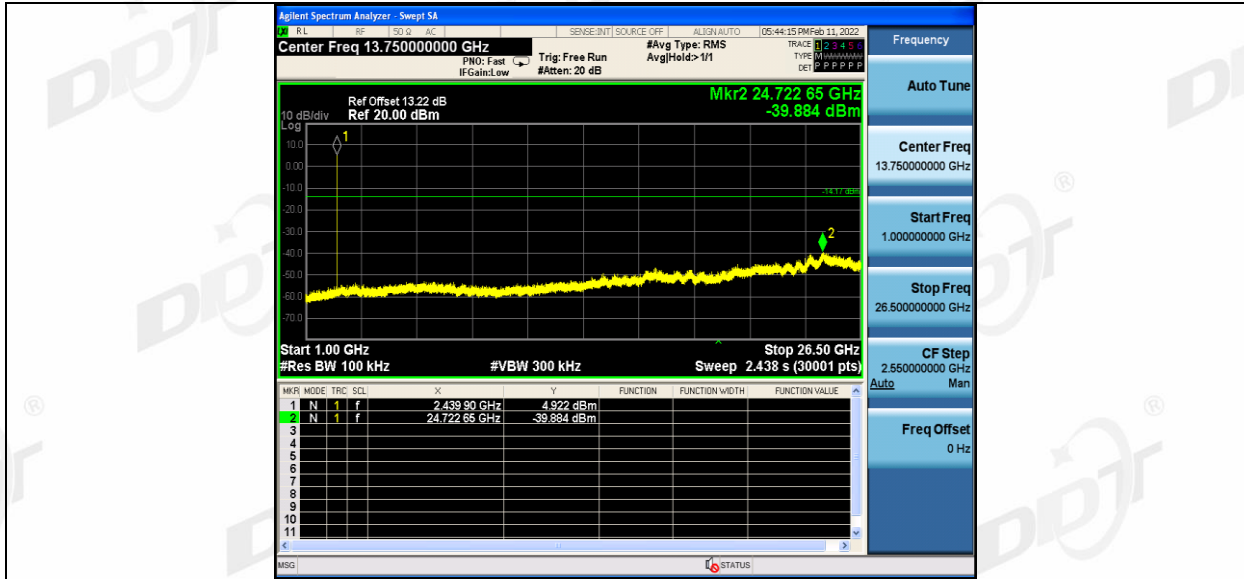

BLE\_1M\_Ant1\_2480\_0~Reference



BLE\_1M\_Ant1\_2480\_30~1000

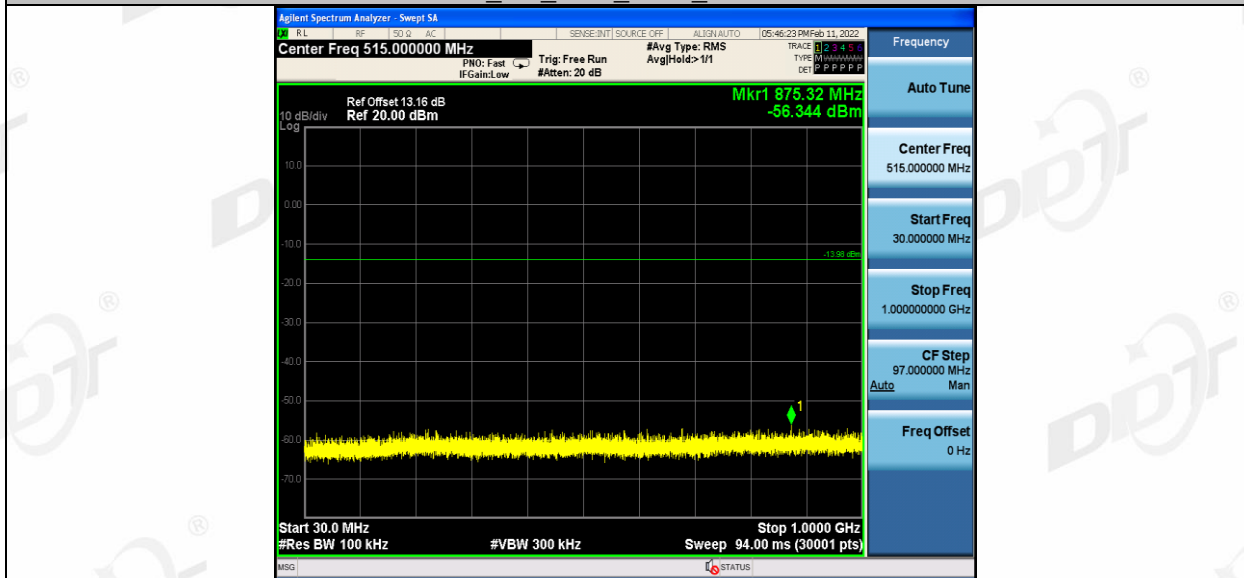

BLE\_1M\_Ant1\_2480\_1000~26500

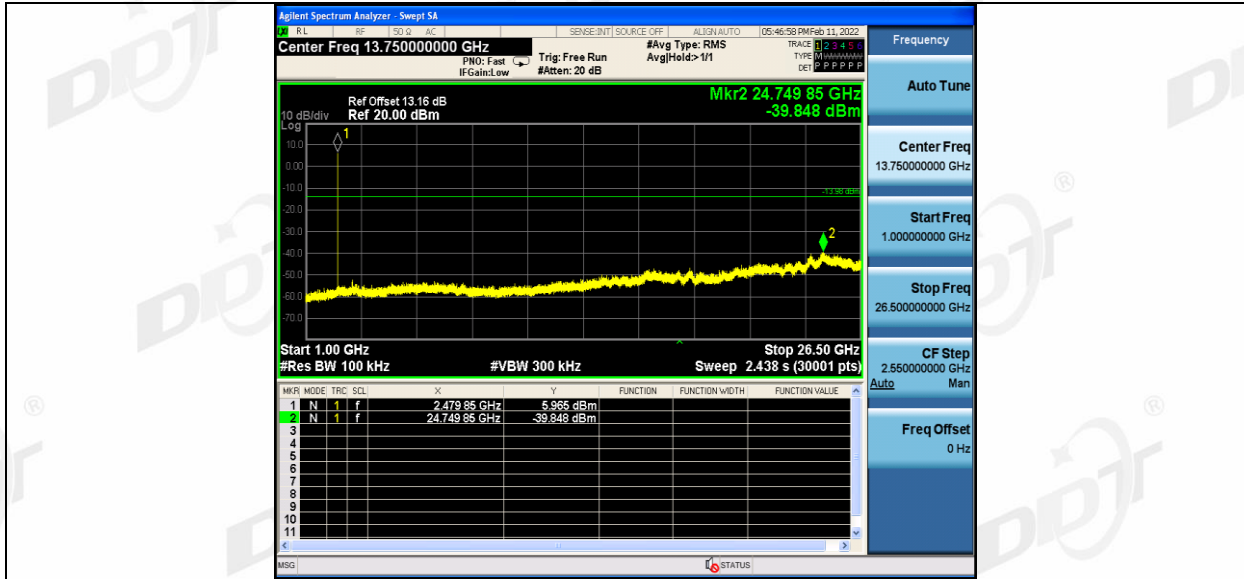

BLE\_2M\_Ant1\_2402\_0~Reference



BLE\_2M\_Ant1\_2402\_30~1000

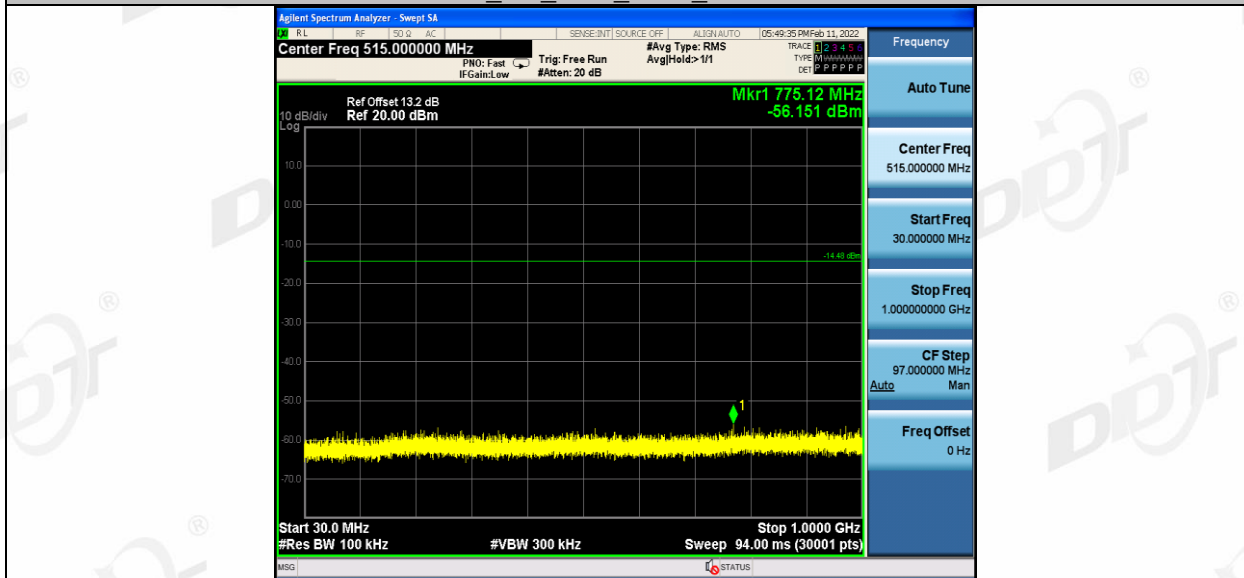

BLE\_2M\_Ant1\_2402\_1000~26500

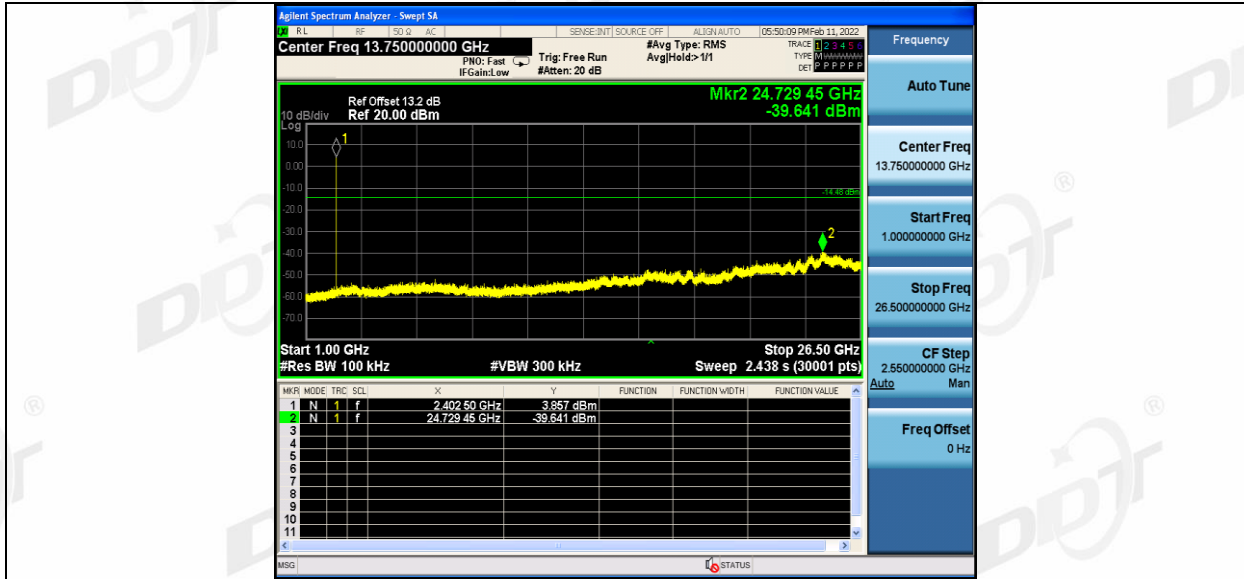

BLE\_2M\_Ant1\_2440\_0~Reference



BLE\_2M\_Ant1\_2440\_30~1000

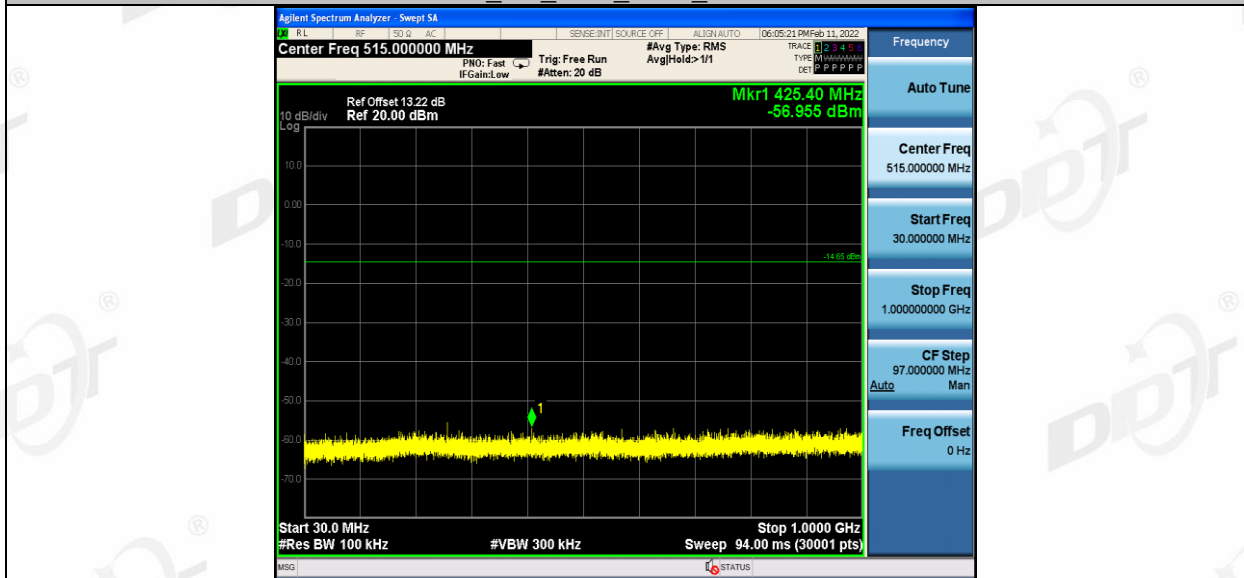

BLE\_2M\_Ant1\_2440\_1000~26500

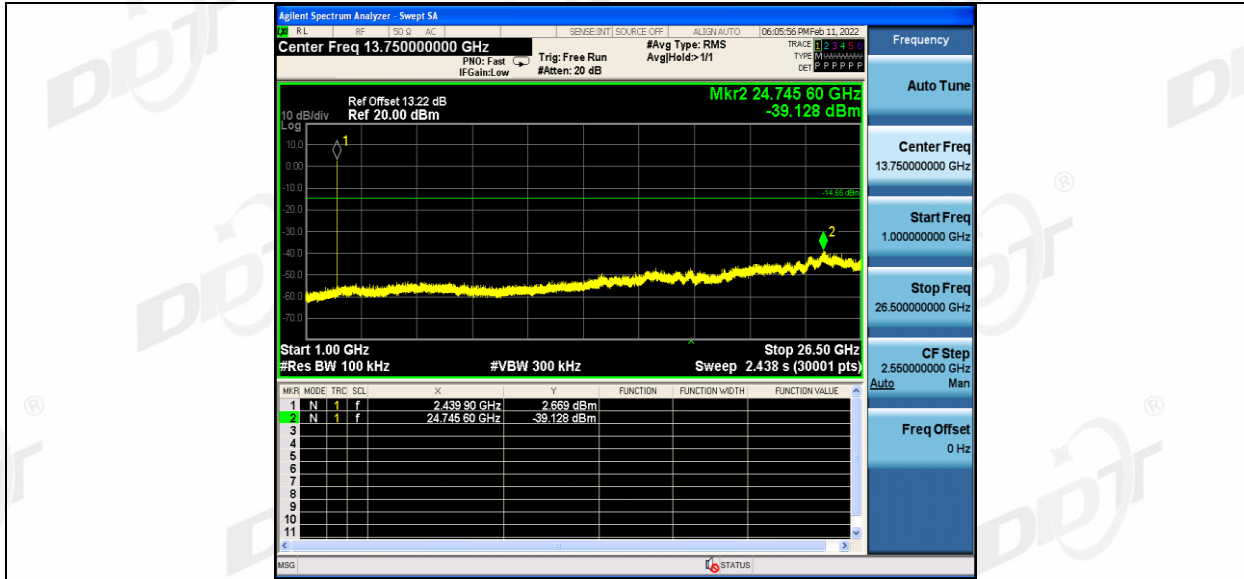

BLE\_2M\_Ant1\_2480\_0~Reference



BLE\_2M\_Ant1\_2480\_30~1000

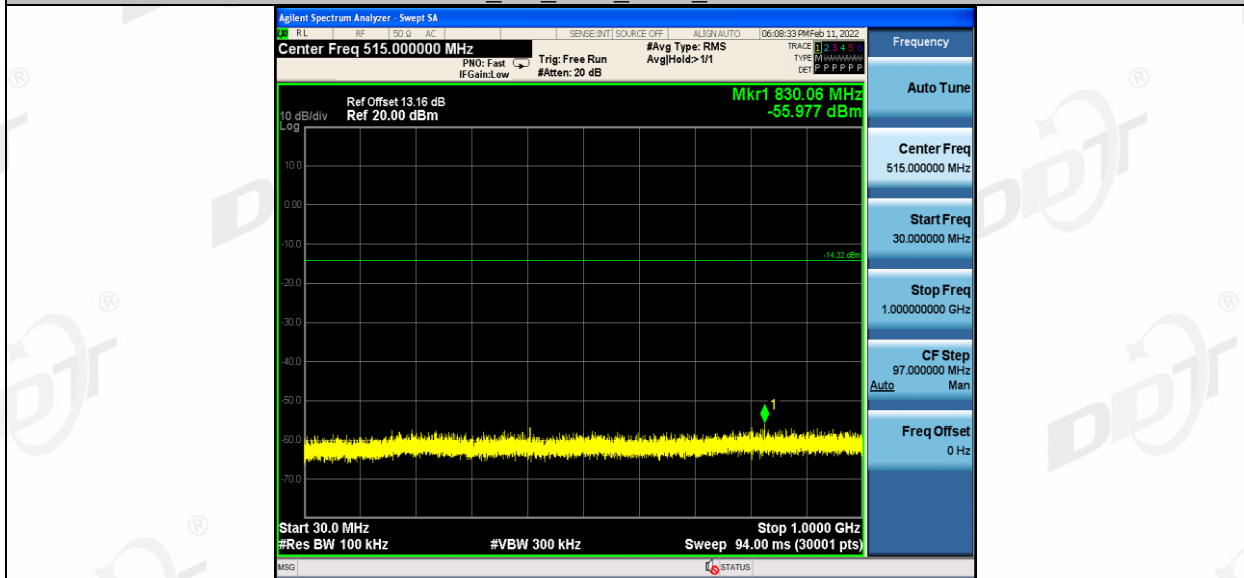

BLE\_2M\_Ant1\_2480\_1000~26500

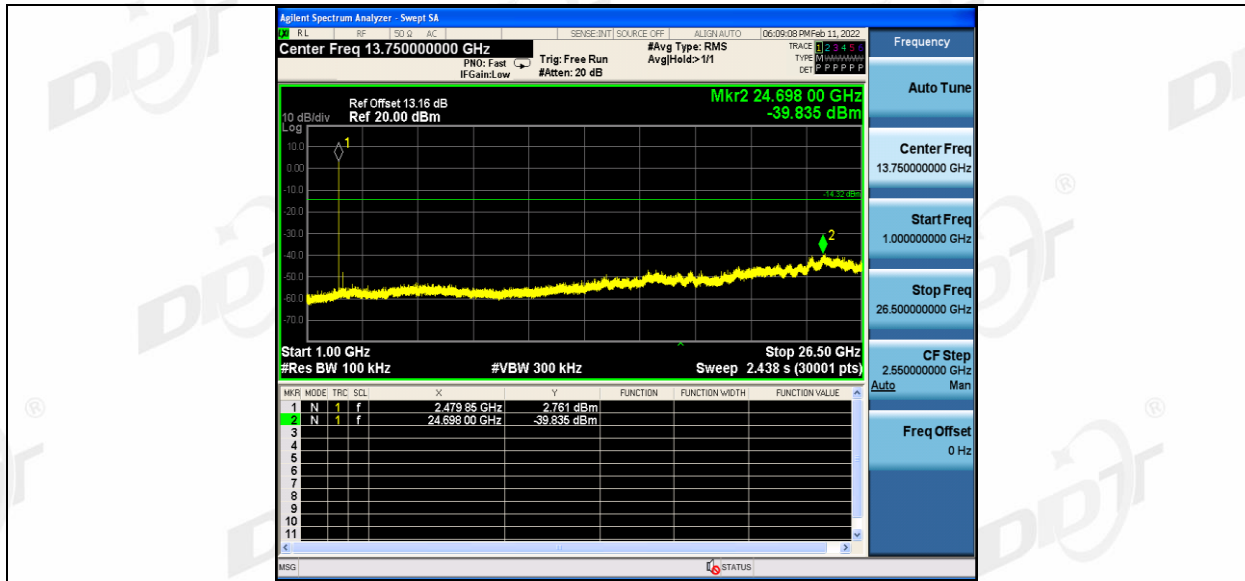



## 10. Emissions in Restricted Frequency Bands

### 10.1. Block diagram of test setup

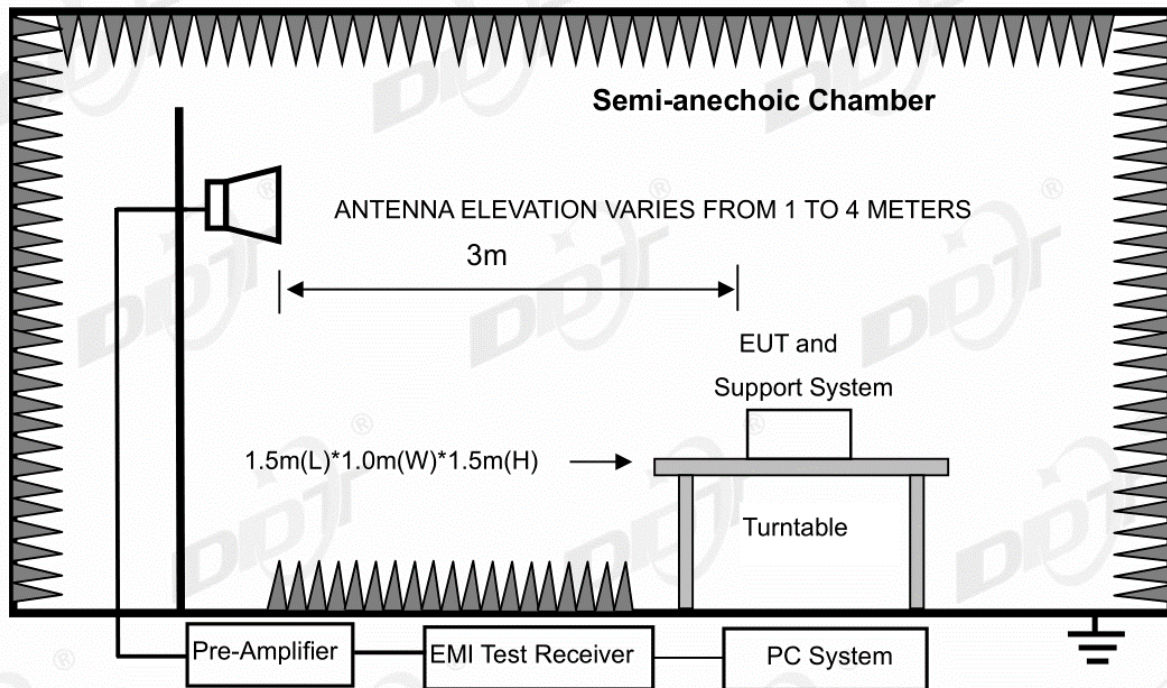

### 10.2. Limit

All restriction band should comply with 15.209 and RSS-Gen section 8.9 limits, other emission should be at least 20 dB below the fundamental.

### 10.3. Test procedure

Same with clause 8.3 except change investigated frequency range from 2310 MHz to 2410 MHz and 2475 MHz to 2500 MHz.

Remark: All restriction band have been tested, and only the worst case is shown in report.

### 10.4. Test result

Pass. (See below detailed test result)



## TR-4-E-009 Radiated Emission Test Result

**Test Site** : DDT 3m Chamber 3#

D:\E3 6.111\2022 Report Data\Q21123009-2E BAR500FCC ABOVE 1G .EM6

**Test Date** : 2022-03-31

**Tested By** : Kennsy Zhang

**EUT** : Multi-Channel Soundbar with wireless subwoofer

**Model Number** : BAR 500

**Power Supply** : AC 120V/60Hz

**Test Mode** : Tx mode

**Condition** : Temp:24.5°C,Humi:55%,Press:100.1kPa

**Antenna/Distance** : 2021 BBHA 9120D 3#/3m/VERTICAL

**Memo** : BLE 1M 2402

Data: 37

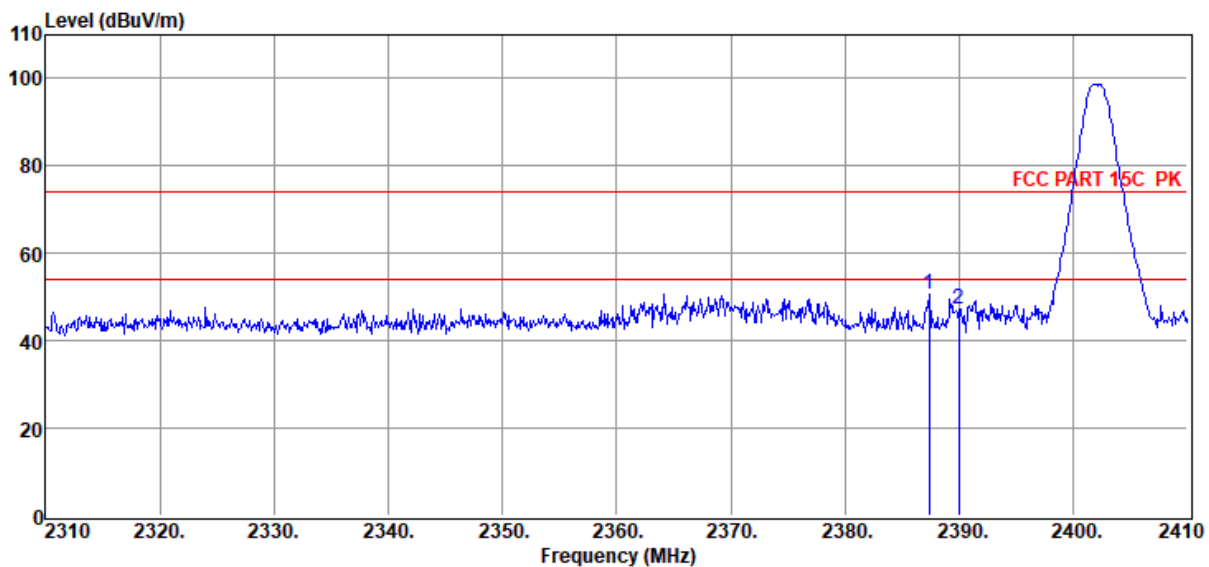

Item (Mark)	Freq. (MHz)	Read Level (dB $\mu$ V)	Antenna Factor (dB/m)	PRM Factor dB	Cable Loss dB	Filter Factor dB	Result Level (dB $\mu$ V/m)	Limit Line (dB $\mu$ V/m)	Over Limit (dB)	Detector	Polarization
1	2387.40	60.52	27.40	39.59	1.71	0.72	50.76	74.00	-23.24	Peak	VERTICAL
2	2390.00	56.84	27.40	39.60	1.71	0.72	47.07	74.00	-26.93	Peak	VERTICAL

Note: 1. Result Level = Read Level + Antenna Factor + Cable loss + Filter Factor - PRM Factor.

2. If Peak Result complies with AV limit, AV Result is deemed to comply with AV limit.

3. Test setup: RBW: 1 MHz, VBW: 3 MHz, Sweep time: auto.

# TR-4-E-009 Radiated Emission Test Result

**Test Site** : DDT 3m Chamber 3#

D:\E3 6.111\2022 Report Data\Q21123009-2E BAR500\FCC ABOVE 1G .EM6

**Test Date** : 2022-03-31

**Tested By** : Kennsy Zhang

**EUT** : Multi-Channel Soundbar with wireless subwoofer

**Model Number** : BAR 500

**Power Supply** : AC 120V/60Hz

**Test Mode** : Tx mode

**Condition** : Temp:24.5°C,Humi:55%,Press:100.1kPa

**Antenna/Distance** : 2021 BBHA 9120D  
3#/3m/HORIZONTAL

**Memo** : BLE 1M 2402

Data: 38

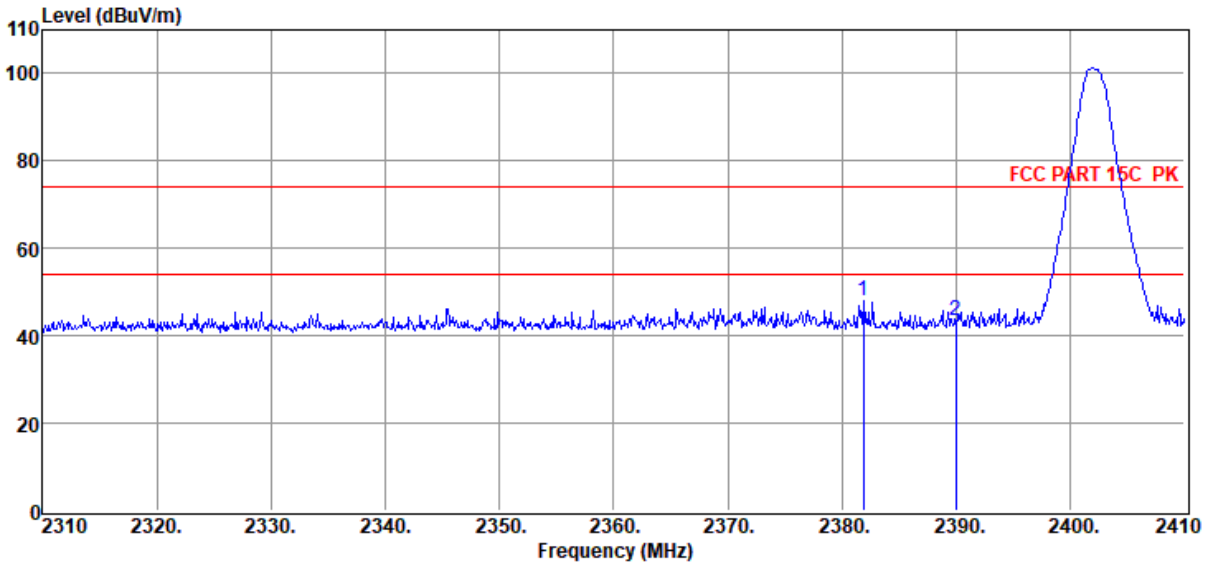

Item (Mark)	Freq. (MHz)	Read Level (dBuV)	Antenna Factor (dB/m)	PRM Factor (dB)	Cable Loss (dB)	Filter Factor (dB)	Result Level (dBuV/m)	Limit Line (dBuV/m)	Over Limit (dB)	Detector	Polarization
1	2381.90	57.72	27.39	39.59	1.71	0.72	47.95	74.00	-26.05	Peak	HORIZONTAL
2	2390.00	53.20	27.40	39.60	1.71	0.72	43.43	74.00	-30.57	Peak	HORIZONTAL

- Note: 1. Result Level = Read Level + Antenna Factor + Cable loss + Filter Factor - PRM Factor.  
 2. If Peak Result complies with AV limit, AV Result is deemed to comply with AV limit.  
 3. Test setup: RBW: 1 MHz, VBW: 3 MHz, Sweep time: auto.

## TR-4-E-009 Radiated Emission Test Result

**Test Site** : DDT 3m Chamber 3#

D:\E3 6.111\2022 Report Data\Q21123009-2E BAR500FCC ABOVE 1G .EM6

**Test Date** : 2022-03-31

**Tested By** : Kensity Zhang

**EUT** : Multi-Channel Soundbar with wireless subwoofer

**Model Number** : BAR 500

**Power Supply** : AC 120V/60Hz

**Test Mode** : Tx mode

**Condition** : Temp:24.5°C,Humi:55%,Press:100.1kPa

**Antenna/Distance** : 2021 BBHA 9120D  
3#/3m/HORIZONTAL

**Memo** : BLE 1M 2480

Data: 39

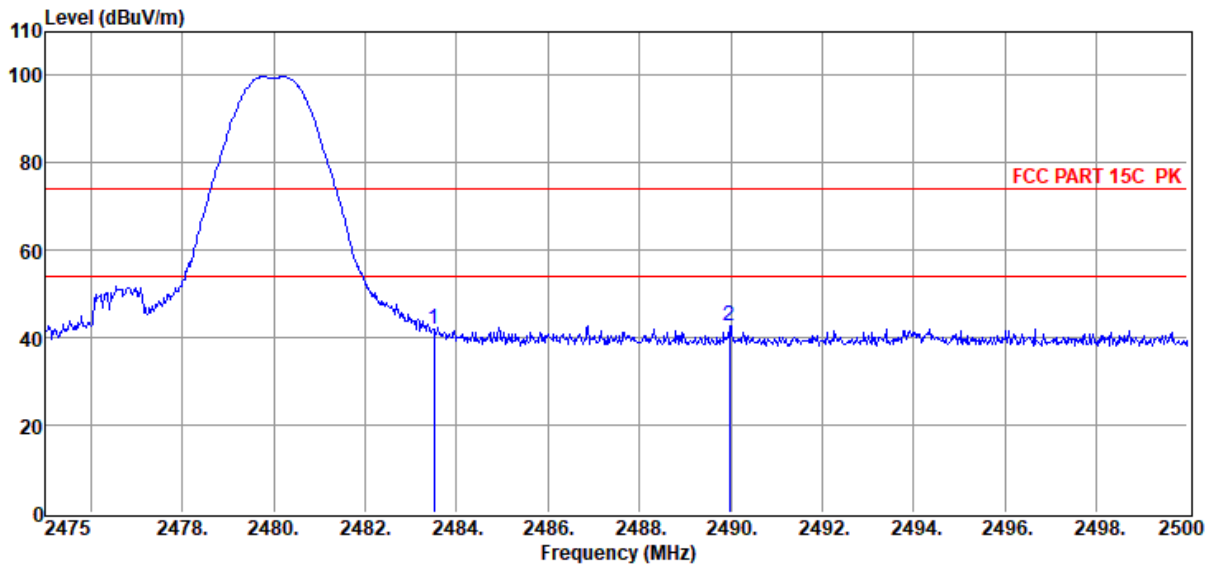

Item (Mark)	Freq. (MHz)	Read Level (dB $\mu$ V)	Antenna Factor (dB/m)	PRM Factor dB	Cable Loss dB	Filter Factor dB	Result Level (dB $\mu$ V/m)	Limit Line (dB $\mu$ V/m)	Over Limit (dB)	Detector	Polarization
1	2483.50	51.55	27.57	39.64	1.74	0.73	41.95	74.00	-32.05	Peak	HORIZONTAL
2	2489.98	52.28	27.58	39.64	1.74	0.73	42.69	74.00	-31.31	Peak	HORIZONTAL

Note: 1. Result Level = Read Level + Antenna Factor + Cable loss + Filter Factor - PRM Factor.

2. If Peak Result complies with AV limit, AV Result is deemed to comply with AV limit.

3. Test setup: RBW: 1 MHz, VBW: 3 MHz, Sweep time: auto.

# TR-4-E-009 Radiated Emission Test Result

**Test Site** : DDT 3m Chamber 3#

D:\E3 6.111\2022 Report Data\Q21123009-2E BAR500\FCC ABOVE 1G .EM6

**Test Date** : 2022-03-31

**Tested By** : Kensity Zhang

**EUT** : Multi-Channel Soundbar with wireless subwoofer

**Model Number** : BAR 500

**Power Supply** : AC 120V/60Hz

**Test Mode** : Tx mode

**Condition** : Temp:24.5°C,Humi:55%,Press:100.1kPa

**Antenna/Distance** : 2021 BBHA 9120D 3#/3m/VERTICAL

**Memo** : BLE 1M 2480

Data: 40

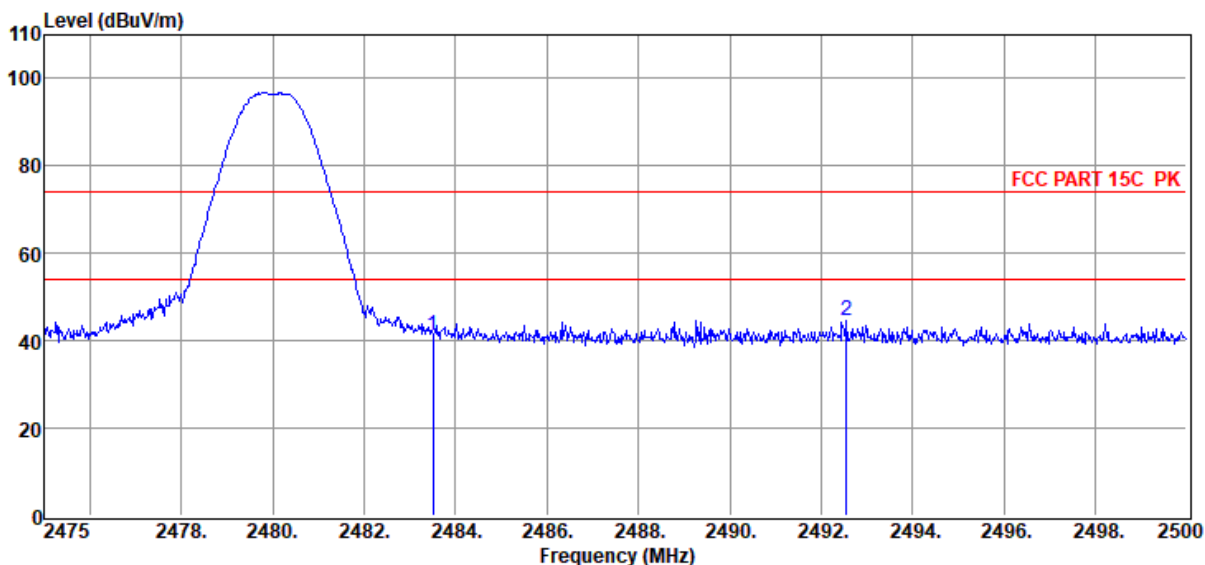

Item (Mark)	Freq. (MHz)	Read Level (dBuV)	Antenna Factor (dB/m)	PRM Factor (dB)	Cable Loss (dB)	Filter Factor (dB)	Result Level (dBuV/m)	Limit Line (dBuV/m)	Over Limit (dB)	Detector	Polarization
1	2483.50	50.62	27.57	39.64	1.74	0.73	41.02	74.00	-32.98	Peak	VERTICAL
2	2492.55	54.32	27.59	39.65	1.74	0.73	44.73	74.00	-29.27	Peak	VERTICAL

Note: 1. Result Level = Read Level + Antenna Factor + Cable loss + Filter Factor - PRM Factor.

2. If Peak Result complies with AV limit, AV Result is deemed to comply with AV limit.

3. Test setup: RBW: 1 MHz, VBW: 3 MHz, Sweep time: auto.

# TR-4-E-009 Radiated Emission Test Result

**Test Site** : DDT 3m Chamber 3#  
**Test Date** : 2022-03-31  
**EUT** : Multi-Channel Soundbar with wireless subwoofer  
**Power Supply** : AC 120V/60Hz  
**Condition** : Temp:24.5°C,Humi:55%,Press:100.1kPa  
**Memo** : BLE 2M 2402

**Tested By** : Kennsy Zhang  
**Model Number** : BAR 500  
**Test Mode** : Tx mode  
**Antenna/Distance** : 2021 BBHA 9120D 3#/3m/VERTICAL

D:\E3 6.111\2022 Report Data\Q21123009-2E BAR500\FCC ABOVE 1G .EM6

Data: 41

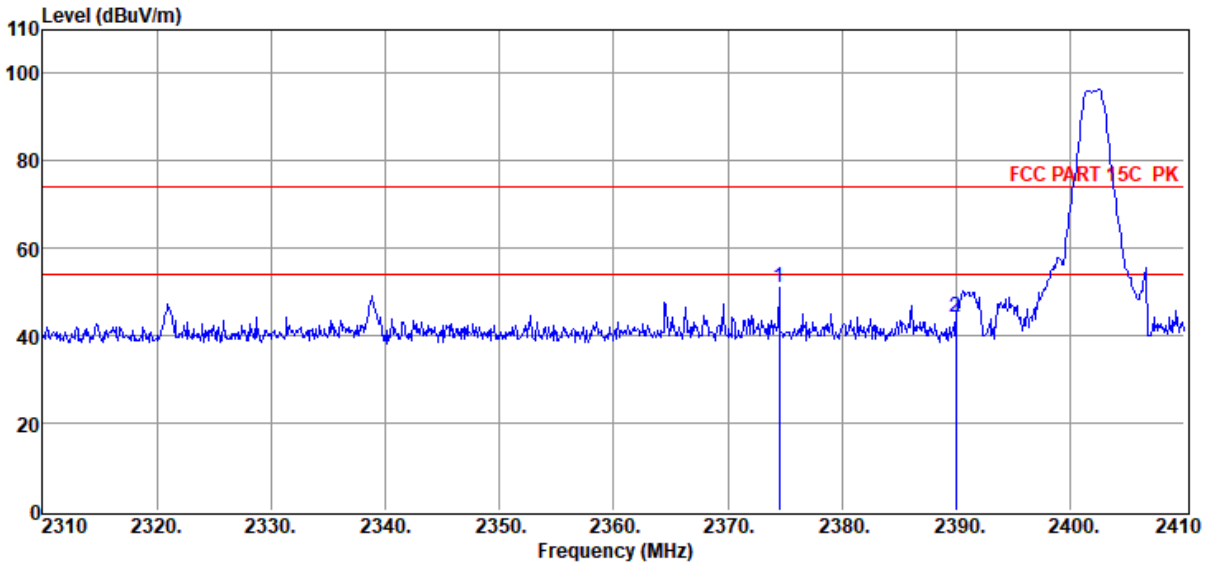

Item (Mark)	Freq. (MHz)	Read Level (dBuV)	Antenna Factor (dB/m)	PRM Factor (dB)	Cable Loss (dB)	Filter Factor (dB)	Result Level (dBuV/m)	Limit Line (dBuV/m)	Over Limit (dB)	Detector	Polarization
1	2374.50	60.67	27.37	39.59	1.70	0.72	50.87	74.00	-23.13	Peak	VERTICAL
2	2390.00	54.01	27.40	39.60	1.71	0.72	44.24	74.00	-29.76	Peak	VERTICAL

- Note: 1. Result Level = Read Level + Antenna Factor + Cable loss + Filter Factor - PRM Factor.  
 2. If Peak Result complies with AV limit, AV Result is deemed to comply with AV limit.  
 3. Test setup: RBW: 1 MHz, VBW: 3 MHz, Sweep time: auto.

# TR-4-E-009 Radiated Emission Test Result

**Test Site** : DDT 3m Chamber 3#

D:\E3 6.111\2022 Report Data\Q21123009-2E BAR500\FCC ABOVE 1G .EM6

**Test Date** : 2022-03-31

**Tested By** : Kennsy Zhang

**EUT** : Multi-Channel Soundbar with wireless subwoofer

**Model Number** : BAR 500

**Power Supply** : AC 120V/60Hz

**Test Mode** : Tx mode

**Condition** : Temp:24.5°C,Humi:55%,Press:100.1kPa

**Antenna/Distance** : 2021 BBHA 9120D 3#/3m/HORIZONTAL

**Memo** : BLE 2M 2402

Data: 42

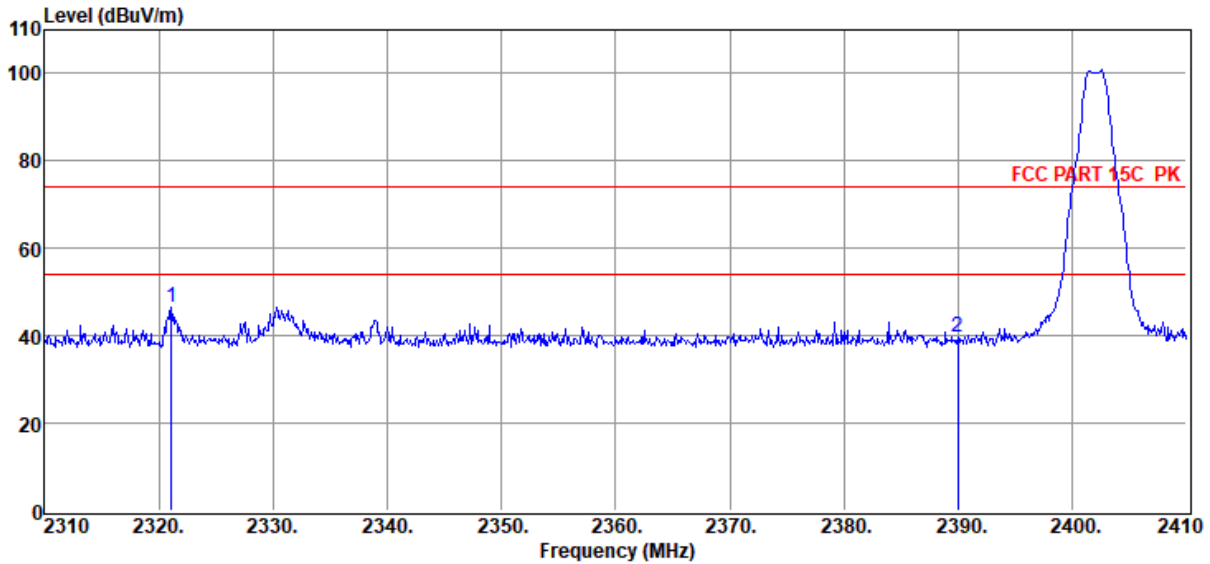

Item (Mark)	Freq. (MHz)	Read Level (dBuV)	Antenna Factor (dB/m)	PRM Factor (dB)	Cable Loss (dB)	Filter Factor (dB)	Result Level (dBuV/m)	Limit Line (dBuV/m)	Over Limit (dB)	Detector	Polarization
1	2321.10	56.37	27.28	39.56	1.69	0.72	46.50	74.00	-27.50	Peak	HORIZONTAL
2	2390.00	49.40	27.40	39.60	1.71	0.72	39.63	74.00	-34.37	Peak	HORIZONTAL

Note: 1. Result Level = Read Level + Antenna Factor + Cable loss + Filter Factor - PRM Factor.

2. If Peak Result complies with AV limit, AV Result is deemed to comply with AV limit.

3. Test setup: RBW: 1 MHz, VBW: 3 MHz, Sweep time: auto.



## TR-4-E-009 Radiated Emission Test Result

**Test Site** : DDT 3m Chamber 3#

D:\E3 6.111\2022 Report Data\Q21123009-2E BAR500\FCC ABOVE 1G .EM6

**Test Date** : 2022-03-31

**Tested By** : Kensity Zhang

**EUT** : Multi-Channel Soundbar with wireless subwoofer

**Model Number** : BAR 500

**Power Supply** : AC 120V/60Hz

**Test Mode** : Tx mode

**Condition** : Temp:24.5°C,Humi:55%,Press:100.1kPa

**Antenna/Distance** : 2021 BBHA 9120D  
3#/3m/HORIZONTAL

**Memo** : BLE 2M 2480

Data: 43

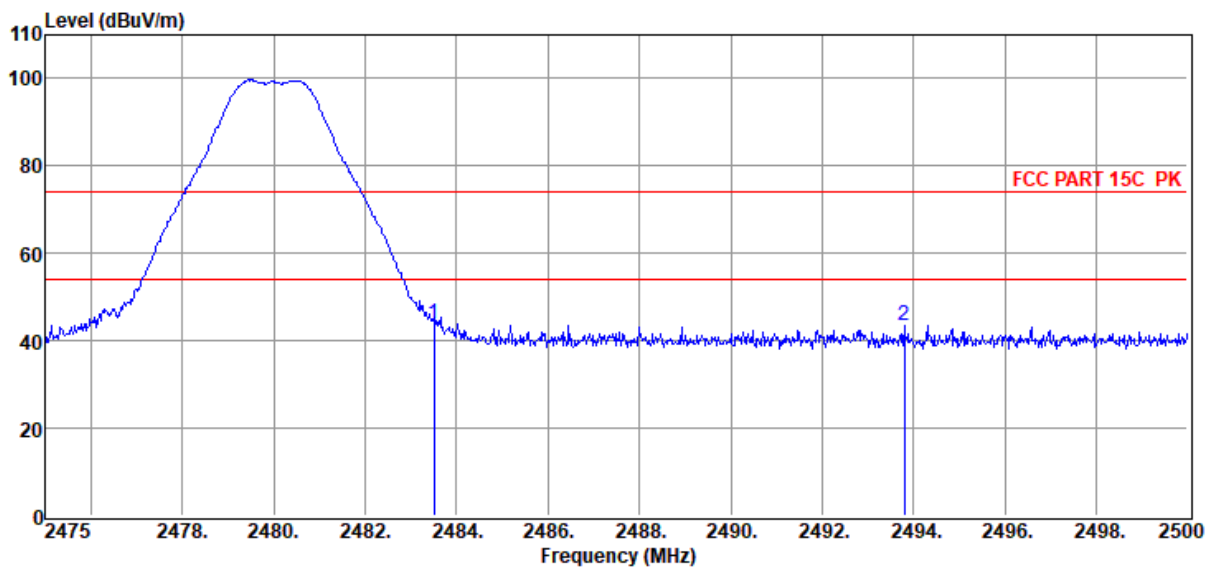

Item (Mark)	Freq. (MHz)	Read Level (dB $\mu$ V)	Antenna Factor (dB/m)	PRM Factor dB	Cable Loss dB	Filter Factor dB	Result Level (dB $\mu$ V/m)	Limit Line (dB $\mu$ V/m)	Over Limit (dB)	Detector	Polarization
1	2483.50	53.52	27.57	39.64	1.74	0.73	43.92	74.00	-30.08	Peak	HORIZONTAL
2	2493.80	53.07	27.59	39.65	1.74	0.73	43.48	74.00	-30.52	Peak	HORIZONTAL

Note: 1. Result Level = Read Level + Antenna Factor + Cable loss + Filter Factor - PRM Factor.

2. If Peak Result complies with AV limit, AV Result is deemed to comply with AV limit.

3. Test setup: RBW: 1 MHz, VBW: 3 MHz, Sweep time: auto.

## TR-4-E-009 Radiated Emission Test Result

**Test Site** : DDT 3m Chamber 3#

D:\E3 6.111\2022 Report Data\Q21123009-2E BAR500\FCC ABOVE 1G .EM6

**Test Date** : 2022-03-31

**Tested By** : Kensity Zhang

**EUT** : Multi-Channel Soundbar with wireless subwoofer

**Model Number** : BAR 500

**Power Supply** : AC 120V/60Hz

**Test Mode** : Tx mode

**Condition** : Temp:24.5°C,Humi:55%,Press:100.1kPa

**Antenna/Distance** : 2021 BBHA 9120D 3#/3m/VERTICAL

**Memo** : BLE 2M 2480

Data: 44

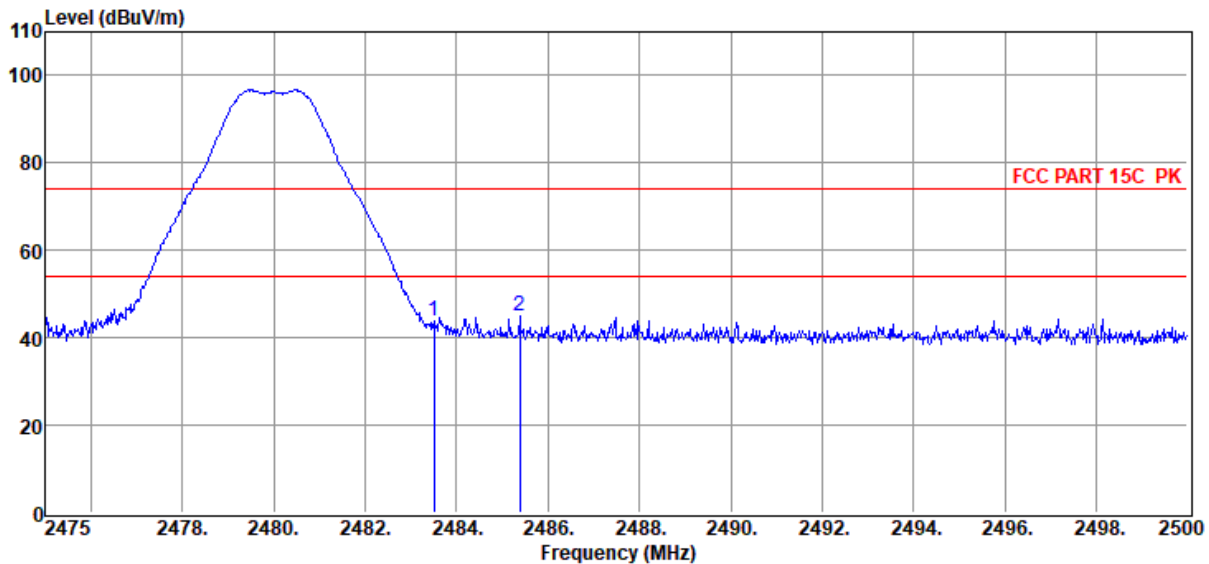

Item (Mark)	Freq. (MHz)	Read Level (dB $\mu$ V)	Antenna Factor (dB/m)	PRM Factor dB	Cable Loss dB	Filter Factor dB	Result Level (dB $\mu$ V/m)	Limit Line (dB $\mu$ V/m)	Over Limit (dB)	Detector	Polarization
1	2483.50	53.43	27.57	39.64	1.74	0.73	43.83	74.00	-30.17	Peak	VERTICAL
2	2485.38	54.55	27.57	39.64	1.74	0.73	44.95	74.00	-29.05	Peak	VERTICAL

Note: 1. Result Level = Read Level + Antenna Factor + Cable loss + Filter Factor - PRM Factor.

2. If Peak Result complies with AV limit, AV Result is deemed to comply with AV limit.

3. Test setup: RBW: 1 MHz, VBW: 3 MHz, Sweep time: auto.

## 11. Power Line Conducted Emission

### 11.1. Block diagram of test setup

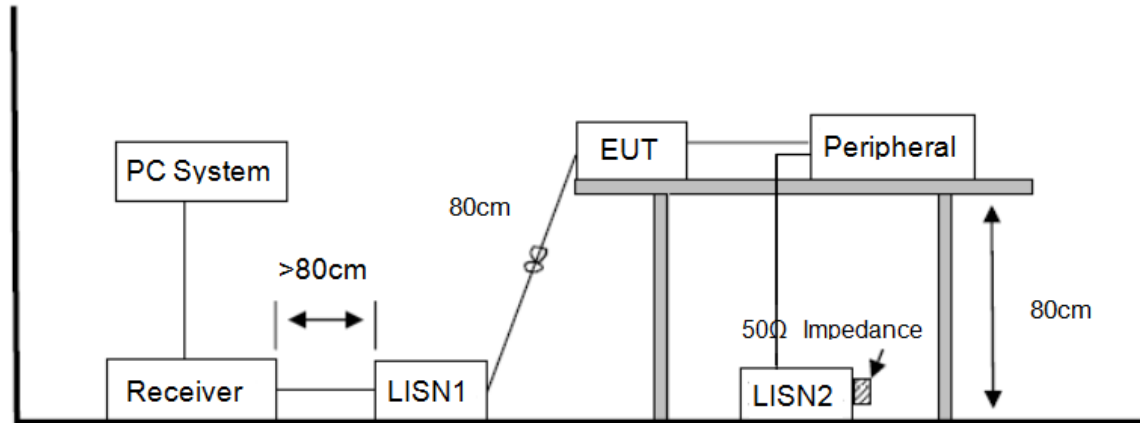

### 11.2. Power line conducted emission limits

Frequency	Quasi-Peak Level dB( $\mu$ V)	Average Level dB( $\mu$ V)
150 kHz ~ 500 kHz	66 ~ 56*	56 ~ 46*
500 kHz ~ 5 MHz	56	46
5 MHz ~ 30 MHz	60	50

Note 1: \* Decreasing linearly with logarithm of frequency.

Note 2: The lower limit shall apply at the transition frequencies.

### 11.3. Test procedure

The EUT and Support equipment, if needed, were put placed on a non-metallic table, 80 cm above the ground plane.

Configuration EUT to simulate typical usage as described in clause 2.4 and test equipment as described in clause 10.2 of this report.

All I/O cables were positioned to simulate typical actual usage as per ANSI C63.10.

All support equipment power received from a second LISN.

Emissions were measured on each current carrying line of the EUT using an EMI Test Receiver connected to the LISN powering the EUT.

The Receiver scanned from 150 kHz to 30 MHz for emissions in each of the test modes.

During the above scans, the emissions were maximized by cable manipulation.

The test mode(s) described in clause 2.4 were scanned during the preliminary test.

After the preliminary scan, we found the test mode producing the highest emission level.

The EUT configuration and worse cable configuration of the above highest emission levels were recorded for reference of the final test.

EUT and support equipment were set up on the test bench as per the configuration with highest emission level in the preliminary test.

A scan was taken on both power lines, Neutral and Line, recording at least the six highest emissions.

Emission frequency and amplitude were recorded into a computer in which correction factors were used to calculate the emission level and compare reading to the applicable limit.

The test data of the worst-case condition(s) was recorded.

The bandwidth of test receiver is set at 9 kHz.

#### **11.4. Test result**

**Pass. (See below detailed test result)**

Note1: All emissions not reported below are too low against the prescribed limits.

Note2: "----" means Peak detection; "----" means Average detection.

Note3: Pre-test AC conducted emission at both voltage AC 120V/60Hz and AC 240V/50Hz, recorded worse case.

# TR-4-E-010 Conducted Emission Test Result

**Test Site** : DDT 1# Shield Room D:\2022 CE report date\Q21123009-2E BAR 500\FCC.EM6  
**Test Date** : 2022-03-18 **Tested By** : Kennys Zhang  
**EUT** : Multi-Channel Soundbar with wireless subwoofer **Model Number** : BAR 500  
**Power Supply** : AC 120V/60Hz **Test Mode** : TX  
**Condition** : TEMP:24.3°C, RH:53.0%, BP:101.0kPa **LISN** : 2021 1# ENV216/NEUTRAL  
**Memo** : BLE

Data: 6

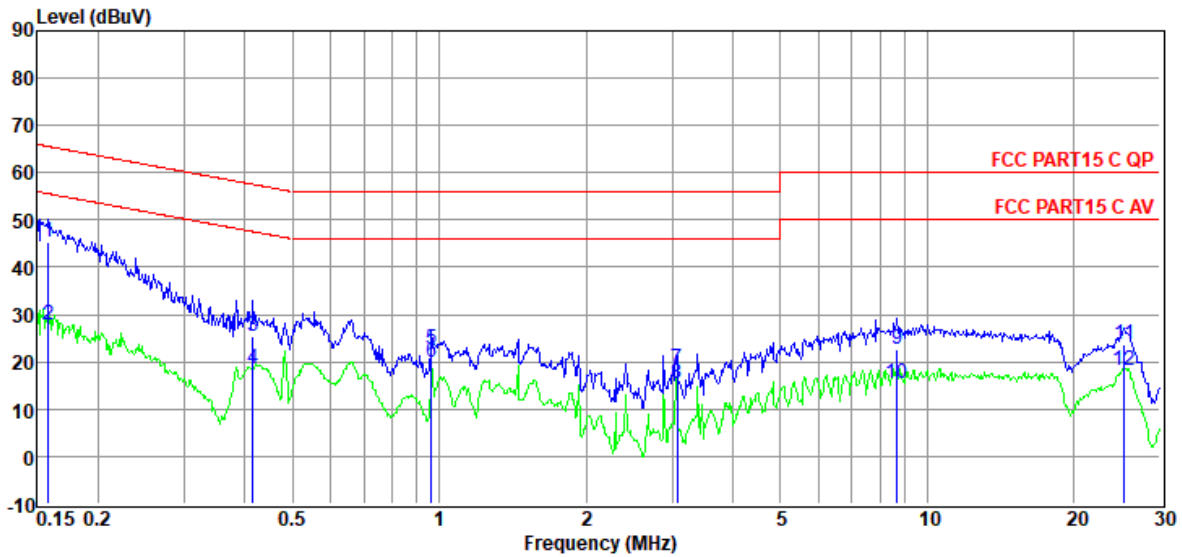

Item (Mark)	Freq. (MHz)	Read Level (dBuV)	LISN Factor (dB)	Cable Loss (dB)	Pulse Limiter Factor (dB)	Result Level (dBuV)	Limit Line (dBuV)	Over Limit (dB)	Detector	Phase
1	0.16	25.75	9.80	0.01	9.92	45.48	65.56	-20.08	QP	NEUTRAL
2	0.16	8.13	9.80	0.01	9.92	27.86	55.56	-27.70	Average	NEUTRAL
3	0.41	5.80	9.56	0.02	9.91	25.29	57.55	-32.26	QP	NEUTRAL
4	0.41	-0.83	9.56	0.02	9.91	18.66	47.55	-28.89	Average	NEUTRAL
5	0.96	3.14	9.71	0.03	9.89	22.77	56.00	-33.23	QP	NEUTRAL
6	0.96	0.36	9.71	0.03	9.89	19.99	46.00	-26.01	Average	NEUTRAL
7	3.07	-1.14	9.72	0.05	9.91	18.54	56.00	-37.46	QP	NEUTRAL
8	3.07	-4.14	9.72	0.05	9.91	15.54	46.00	-30.46	Average	NEUTRAL
9	8.68	2.87	9.72	0.10	9.94	22.63	60.00	-37.37	QP	NEUTRAL
10	8.68	-4.33	9.72	0.10	9.94	15.43	50.00	-34.57	Average	NEUTRAL
11	25.32	3.75	9.86	0.19	9.98	23.78	60.00	-36.22	QP	NEUTRAL
12	25.32	-2.00	9.86	0.19	9.98	18.03	50.00	-31.97	Average	NEUTRAL

Note:

1. Result Level = Read Level + LISN Factor + Pulse Limiter Factor + Cable loss.
2. If QP Result complies with AV limit, AV Result is deemed to comply with AV limit.
3. Test setup: RBW: 200 Hz (9 kHz—150 kHz), 9 kHz (150 kHz—30 MHz).
4. Step size: 80Hz (0.009MHz-0.15MHz), 4 kHz (0.15MHz-30MHz), Scan time: auto.

# TR-4-E-010 Conducted Emission Test Result

**Test Site** : DDT 1# Shield Room **D:\2022 CE report date\Q21123009-2E BAR 500\FCC.EM6**  
**Test Date** : 2022-03-18 **Tested By** : Kennys Zhang  
**EUT** : Multi-Channel Soundbar with wireless subwoofer **Model Number** : BAR 500  
**Power Supply** : AC 120V/60Hz **Test Mode** : TX  
**Condition** : TEMP:24.3°C, RH:53.0%, BP:101.0kPa **LISN** : 2021 1# ENV216/LINE  
**Memo** : BLE

Data: 8

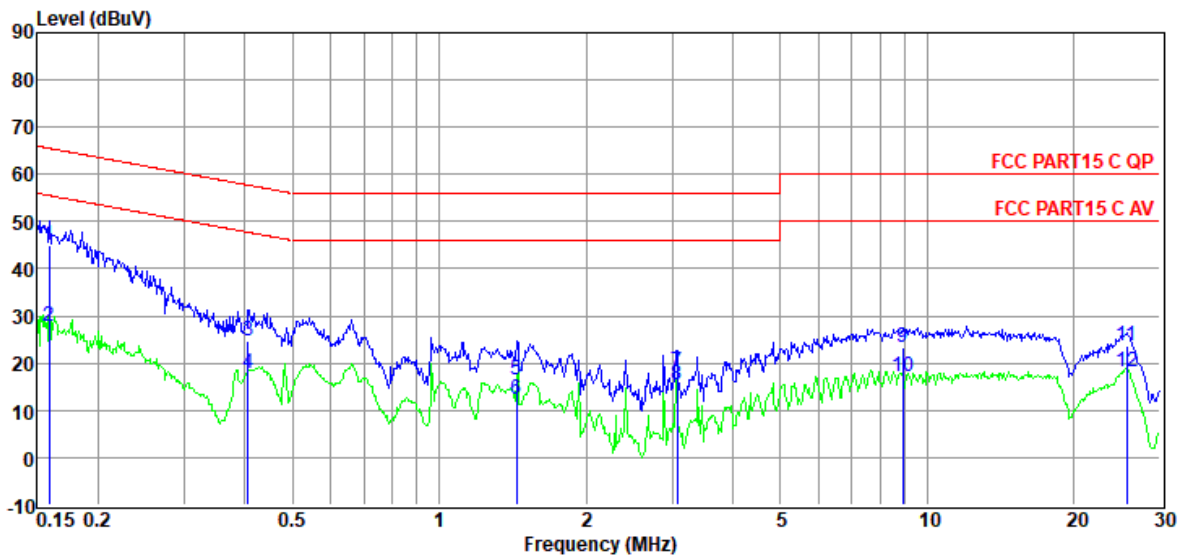

Item (Mark)	Freq. (MHz)	Read Level (dBuV)	LISN Factor (dB)	Cable Loss (dB)	Pulse Limiter Factor (dB)	Result Level (dBuV)	Limit Line (dBuV)	Over Limit (dB)	Detector	Phase
1	0.16	25.32	9.64	0.01	9.92	44.89	65.52	-20.63	QP	LINE
2	0.16	8.14	9.64	0.01	9.92	27.71	55.52	-27.81	Average	LINE
3	0.41	5.22	9.65	0.02	9.91	24.80	57.73	-32.93	QP	LINE
4	0.41	-1.74	9.65	0.02	9.91	17.84	47.73	-29.89	Average	LINE
5	1.44	-3.10	9.55	0.04	9.89	16.38	56.00	-39.62	QP	LINE
6	1.44	-7.15	9.55	0.04	9.89	12.33	46.00	-33.67	Average	LINE
7	3.07	-1.17	9.56	0.05	9.91	18.35	56.00	-37.65	QP	LINE
8	3.07	-3.92	9.56	0.05	9.91	15.60	46.00	-30.40	Average	LINE
9	8.92	3.68	9.50	0.10	9.94	23.22	60.00	-36.78	QP	LINE
10	8.92	-2.56	9.50	0.10	9.94	16.98	50.00	-33.02	Average	LINE
11	25.59	4.01	9.66	0.19	9.98	23.84	60.00	-36.16	QP	LINE
12	25.59	-1.49	9.66	0.19	9.98	18.34	50.00	-31.66	Average	LINE

**Note:**

1. Result Level = Read Level + LISN Factor + Pulse Limiter Factor + Cable loss.
2. If QP Result complies with AV limit, AV Result is deemed to comply with AV limit.
3. Test setup: RBW: 200 Hz (9 kHz—150 kHz), 9 kHz (150 kHz—30 MHz).
4. Step size: 80Hz (0.009MHz-0.15MHz), 4 kHz (0.15MHz-30MHz), Scan time: auto.



# TR-4-E-010 Conducted Emission Test Result

**Test Site** : DDT 1# Shield Room **D:**2022 CE report date\Q21123009-2E BAR 500\FCC.EM6  
**Test Date** : 2022-03-18 **Tested By** : Kennys Zhang  
**EUT** : Multi-Channel Soundbar with wireless subwoofer **Model Number** : BAR 500  
**Power Supply** : AC 120V/60Hz **Test Mode** : TX  
**Condition** : TEMP:24.3°C, RH:53.0%, BP:101.0kPa **LISN** : 2021 1# ENV216/LINE  
**Memo** : BLE 2M

Data: 10

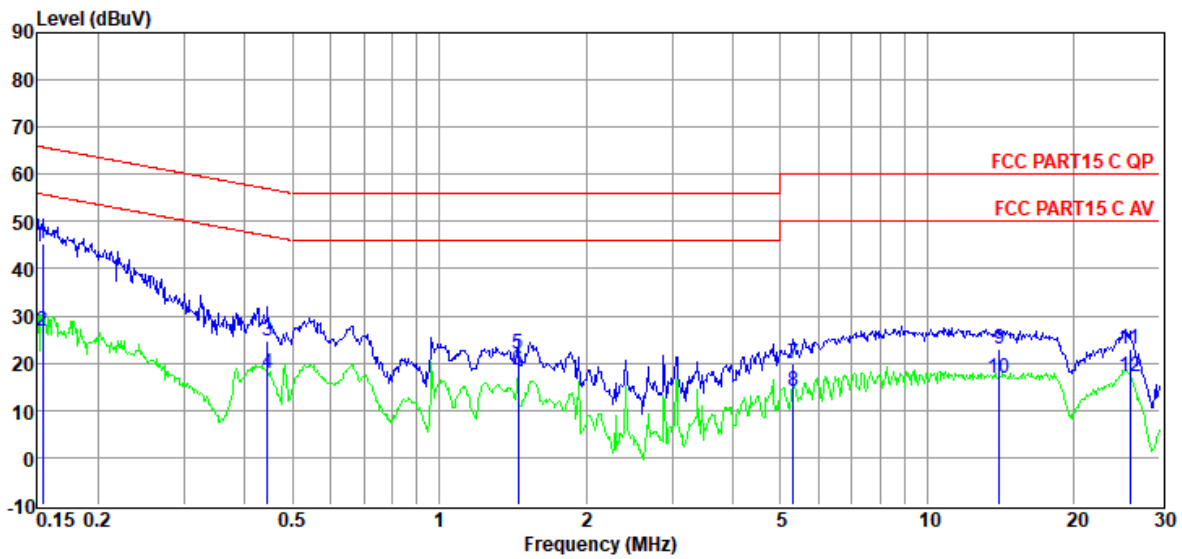

Item	Freq.	Read Level	LISN Factor	Cable Loss	Pulse Limiter Factor	Result Level	Limit Line	Over Limit	Detector	Phase
(Mark)	(MHz)	(dBμV)	(dB)	(dB)	(dB)	(dBμV)	(dBμV)	(dB)		
1	0.15	25.86	9.62	0.01	9.92	45.41	65.78	-20.37	QP	LINE
2	0.15	7.34	9.62	0.01	9.92	26.89	55.78	-28.89	Average	LINE
3	0.44	5.07	9.63	0.02	9.91	24.63	56.98	-32.35	QP	LINE
4	0.44	-1.62	9.63	0.02	9.91	17.94	46.98	-29.04	Average	LINE
5	1.45	2.39	9.55	0.04	9.89	21.87	56.00	-34.13	QP	LINE
6	1.45	-1.05	9.55	0.04	9.89	18.43	46.00	-27.57	Average	LINE
7	5.31	0.52	9.55	0.06	9.93	20.06	60.00	-39.94	QP	LINE
8	5.31	-5.61	9.55	0.06	9.93	13.93	50.00	-36.07	Average	LINE
9	14.06	3.24	9.75	0.14	9.93	23.06	60.00	-36.94	QP	LINE
10	14.06	-3.10	9.75	0.14	9.93	16.72	50.00	-33.28	Average	LINE
11	26.00	3.18	9.66	0.19	9.99	23.02	60.00	-36.98	QP	LINE
12	26.00	-2.58	9.66	0.19	9.99	17.26	50.00	-32.74	Average	LINE

**Note:**

1. Result Level = Read Level + LISN Factor + Pulse Limiter Factor + Cable loss.
2. If QP Result complies with AV limit, AV Result is deemed to comply with AV limit.
3. Test setup: RBW: 200 Hz (9 kHz—150 kHz), 9 kHz (150 kHz—30 MHz).
4. Step size: 80Hz (0.009MHz-0.15MHz), 4 kHz (0.15MHz-30MHz), Scan time: auto.

# TR-4-E-010 Conducted Emission Test Result

**Test Site** : DDT 1# Shield Room **D:\2022 CE report date\Q21123009-2E BAR 500\FCC.EM6**  
**Test Date** : 2022-03-18 **Tested By** : Kennys Zhang  
**EUT** : Multi-Channel Soundbar with wireless subwoofer **Model Number** : BAR 500  
**Power Supply** : AC 120V/60Hz **Test Mode** : TX  
**Condition** : TEMP:24.3°C, RH:53.0%, BP:101.0kPa **LISN** : 2021 1# ENV216/NEUTRAL  
**Memo** : BLE 2M

Data: 12

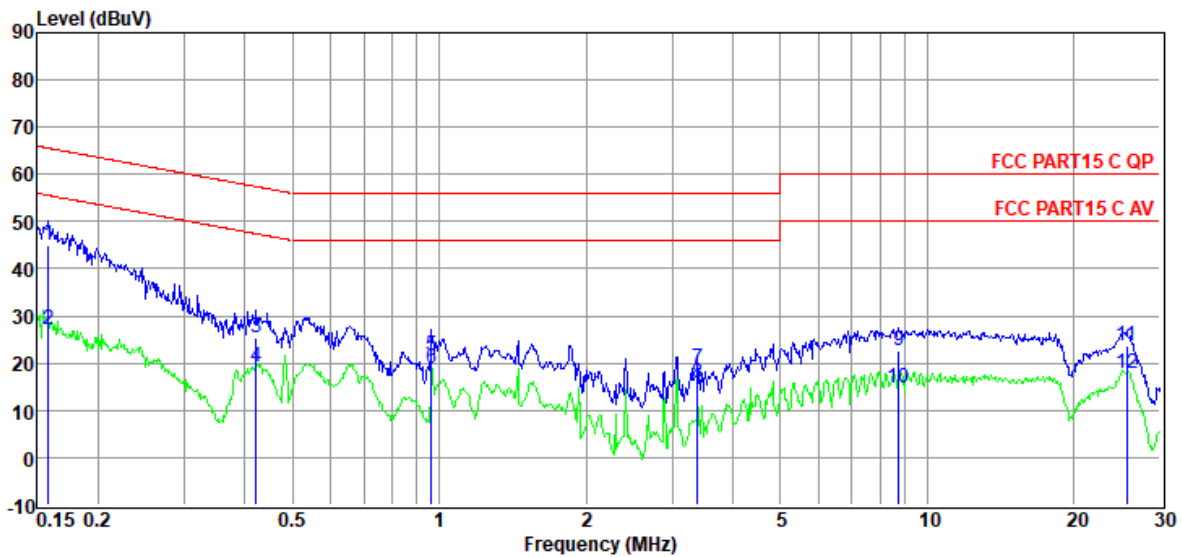

Item	Freq.	Read Level	LISN Factor	Cable Loss	Pulse Limiter Factor	Result Level	Limit Line	Over Limit	Detector	Phase
(Mark)	(MHz)	(dBuV)	(dB)	(dB)	(dB)	(dBuV)	(dBuV)	(dB)		
1	0.16	25.26	9.80	0.01	9.92	44.99	65.56	-20.57	QP	NEUTRAL
2	0.16	7.24	9.80	0.01	9.92	26.97	55.56	-28.59	Average	NEUTRAL
3	0.42	5.85	9.56	0.02	9.91	25.34	57.42	-32.08	QP	NEUTRAL
4	0.42	-0.39	9.56	0.02	9.91	19.10	47.42	-28.32	Average	NEUTRAL
5	0.96	2.12	9.71	0.03	9.89	21.75	56.00	-34.25	QP	NEUTRAL
6	0.96	-0.77	9.71	0.03	9.89	18.86	46.00	-27.14	Average	NEUTRAL
7	3.38	-0.75	9.75	0.05	9.91	18.96	56.00	-37.04	QP	NEUTRAL
8	3.38	-4.08	9.75	0.05	9.91	15.63	46.00	-30.37	Average	NEUTRAL
9	8.73	2.77	9.72	0.10	9.94	22.53	60.00	-37.47	QP	NEUTRAL
10	8.73	-4.97	9.72	0.10	9.94	14.79	50.00	-35.21	Average	NEUTRAL
11	25.59	3.76	9.86	0.19	9.98	23.79	60.00	-36.21	QP	NEUTRAL
12	25.59	-2.04	9.86	0.19	9.98	17.99	50.00	-32.01	Average	NEUTRAL

**Note:**

1. Result Level = Read Level + LISN Factor + Pulse Limiter Factor + Cable loss.
2. If QP Result complies with AV limit, AV Result is deemed to comply with AV limit.
3. Test setup: RBW: 200 Hz (9 kHz—150 kHz), 9 kHz (150 kHz—30 MHz).
4. Step size: 80Hz (0.009MHz-0.15MHz), 4 kHz (0.15MHz-30MHz), Scan time: auto.

## 12. Antenna Requirements

### 12.1. Limit

For intentional device, according to FCC 47 CFR Section 15.203, an intentional radiator shall be designed to ensure that no antenna other than that furnished by the responsible party shall be used with the device. And according to FCC 47 CFR Section 15.247 (b), if transmitting antennas of directional gain greater than 6 dBi are used, the power shall be reduced by the amount in dB that the directional gain of the antenna exceeds 6 dBi.

For intentional device, according to RSS-Gen issue 5 section 6.8.

The applicant for equipment certification shall provide a list of all antenna types that may be used with the transmitter, where applicable (i.e. for transmitters with detachable antenna), indicating the maximum permissible antenna gain (in dBi) and the required impedance for each antenna. The test report shall demonstrate the compliance of the transmitter with the limit for maximum equivalent isotropically radiated power (e.i.r.p.) specified in the applicable RSS, when the transmitter is equipped with any antenna type, selected from this list.

### 12.2. Result

The product is that no antenna other than that furnished by the responsible party shall be used with the device, the maximum peak gain of the transmit antenna is 2.26 dBi.