

FCC AND IC CERTIFICATION TEST REPORT

FOR

Applicant	:	Harman International Industries, Inc.
Address	:	8500 Balboa Boulevard, Northridge, CA 91329, UNITED STATES
Equipment under Test	:	SOUNDBAR
Model No.	:	Bar 2.1 Deep Bass CNTR
Trade Mark	:	JBL
FCC ID	:	APIBAR300CNTR
IC	:	6132A-BAR300CNTR
Manufacturer	:	Harman International Industries, Inc.
Address	:	8500 Balboa Boulevard, Northridge, CA 91329, UNITED STATES

Issued By: Dongguan Dongdian Testing Service Co., Ltd.

Add: No. 17, Zongbu Road 2, Songshan Lake Sci&Tech, Industry Park, Dongguan
City, Guangdong Province, China, 523808

Tel: +86-0769-38826678, **E-mail:** ddt@dgddt.com, <http://www.dgddt.com>

TABLE OF CONTENTS

	Test report declares.....	4
1.	Summary of test results	6
2.	General test information	7
2.1.	Description of EUT	7
2.2.	Accessories of EUT	7
2.3.	Assistant equipment used for test	7
2.4.	Block diagram of EUT configuration for test.....	7
2.5.	Deviations of test standard	8
2.6.	Test environment conditions.....	8
2.7.	Test laboratory	8
2.8.	Measurement uncertainty	8
3.	Equipment used during test	9
4.	26dB Bandwidth, 6dB Bandwidth and 99% Bandwidth.....	10
4.1.	Block diagram of test setup	10
4.2.	Limits	10
4.3.	Test Procedure.....	10
4.4.	Test Result	11
4.5.	Original test data	11
5.	Maximum Output Power	14
5.1.	Block diagram of test setup	14
5.2.	Limits	14
5.3.	Test Procedure.....	14
5.4.	Test Result	14
6.	Power Spectral Density.....	16
6.1.	Block diagram of test setup	16
6.2.	Limits	16
6.3.	Test Procedure.....	16
6.4.	Test Result	17
6.5.	Original test data	17
7.	Frequency Stability Measurement	19
7.1.	Limit of Frequency Stability.....	19
7.2.	Measuring Instruments	19
7.3.	Test Procedures.....	19
7.4.	Test Setup	19
7.5.	Test Result	19
8.	Emissions in restricted frequency bands.....	21
8.1.	Block diagram of test setup	21
8.2.	Limit.....	22

8.3.	Test Procedure.....	23
8.4.	Test result.....	25
9.	Band Edge Compliance	29
9.1.	Block diagram of test setup	29
9.2.	Limit.....	29
9.3.	Test Procedure.....	29
9.4.	Test result.....	29
10.	Power Line Conducted Emission.....	36
10.1.	Block diagram of test setup	36
10.2.	Power Line Conducted Emission Limits (Class B).....	36
10.3.	Test Procedure.....	36
10.4.	Test Result	37
11.	Antenna Requirements	40
11.1.	Limit.....	40
11.2.	Result	40

TEST REPORT DECLARE

Applicant	:	Harman International Industries, Inc.
Address	:	8500 Balboa Boulevard, Northridge, CA 91329, UNITED STATES
Equipment under Test	:	SOUNDBAR
Model No	:	Bar 2.1 Deep Bass CNTR
Trade Mark	:	JBL
Manufacturer	:	Harman International Industries, Inc.
Address	:	8500 Balboa Boulevard, Northridge, CA 91329, UNITED STATES

Test Standard Used: FCC Rules and Regulations Part 15 Subpart C, RSS-247 Issue 2 February 2017.

Test procedure used: ANSI C63.10:2013, 789033 D02 General U-NII Test Procedures New Rules v02r01, RSS-Gen Issue 5, Apr. 2018

We Declare:

The equipment described above is tested by Dongguan Dongdian Testing Service Co., Ltd and in the configuration tested the equipment complied with the standards specified above. The test results are contained in this test report and Dongguan Dongdian Testing Service Co., Ltd is assumed of full responsibility for the accuracy and completeness of these tests.

After test and evaluation, our opinion is that the equipment provided for test compliance with the requirement of the above FCC&IC standards.

Report No:	DDT-R18112313-1E6		
Date of Receipt:	Feb. 19, 2019	Date of Test:	Feb. 19, 2019 ~ Apr. 04, 2019

Prepared By:

Ella Gong

Ella Gong/Engineer

Approved By:



Damon Hu/EMC Manager

Note: This report applies to above tested sample only. This report shall not be reproduced in parts without written approval of Dongguan Dongdian Testing Service Co., Ltd.

Revision history

Rev.	Revisions	Issue Date	Revised By
---	Initial issue	Apr. 04, 2019	

1. Summary of test results

The EUT have been tested according to the applicable standards as referenced below.		
Description of Test Item	Standard	Results
6/26db Bandwidth and 99% Bandwidth	FCC 15.407 (e) RSS-247 Clause 6.2	PASS
Maximum Conducted Output Power	FCC 15.407 (a) RSS-247 Clause 6.2	PASS
Power Spectral Density	FCC 15.407 (a) RSS-247 Clause 6.2	PASS
Frequency Stability Measurement	FCC 15.407 (g)	PASS
Emissions in restricted frequency bands	FCC 15.407 (a) FCC 15.209 FCC 15.205 RSS-247 Clause 6.2 RSS-GEN Clause 8.9	PASS
Band Edge Compliance	FCC 15.407 (a) FCC 15.209 FCC 15.205 RSS-247 Clause 6.2 RSS-GEN Clause 8.9	PASS
Power Line Conducted Emission	FCC 15.207 RSS-GEN Clause 8.8	PASS
Antenna requirement	FCC 15.203 RSS-GEN Clause 8.3	PASS
Dynamic Frequency Selection	FCC 15.407 (h) RSS-247 Clause 6.3	N/A
Note: N/A is an abbreviation for Not Applicable.		

2. General test information

2.1. Description of EUT

EUT* Name	: SOUNDBAR
Model Number	: Bar 2.1 Deep Bass CNTR
EUT function description	: Please reference user manual of this device
Power supply	: AC 100-240 V, 50/60 Hz
Radio Technology	: SRD
FCC Operation frequency	: 5736.35 MHz-5820.35 MHz
Modulation	: $\pi/4$ -DQPSK
Antenna Type	: Antenna 1: Printed antenna, maximum PK gain 3.39 dBi Antenna 2: Printed antenna, maximum PK gain 3.50 dBi
Sample Type	: Series production

Note 1: EUT is the ab. of equipment under test.

Note 2: The EUT supports the antenna with TX and RX diversity functions.

Both Port 1(Ant. 1) and Port 2(Ant. 2) support transmit and receive functions, but only one of them will be used at one time, and Port 1(Ant. 1) generated the worst case, so it was selected to test and record in the report.

2.2. Accessories of EUT

Assistant equipment	Manufacturer	Model number	Serial No.	Other
AC cable	Harman	N/A	N/A	Length: 1.5m, unshielded
Remote Control Unit	Harman	N/A	N/A	N/A

2.3. Assistant equipment used for test

Assistant equipment	Manufacturer	Model number	EMC Compliance	SN
Notebook	DELL	Latitude D610	FCC DOC	00045-534-136-300

2.4. Block diagram of EUT configuration for test

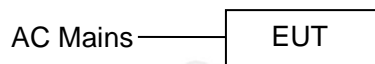

EUT was connected to control to provide by manufacturer which has a standard LAN port connector to connect to Notebook, and the Notebook will run a special test software "VMIttest-1.1.6.56. EXE" provided by manufacturer to control EUT work in Continuous Tx mode (>98% duty cycle), and select test channel, wireless mode.

Mode	Setting Tx Power	Channel	Frequency (MHz)
$\pi/4$ -DQPSK	0x06	Low	5736.35
	0x06	Middle	5776.35
	0x06	High	5820.35

2.5. Deviations of test standard

No Deviation.

2.6. Test environment conditions

During the measurement the environmental conditions were within the listed ranges:

Temperature range:	21-25°C
Humidity range:	40-75%
Pressure range:	86-106kPa

2.7. Test laboratory

Dongguan Dongdian Testing Service Co., Ltd

Add: No. 17, Zongbu Road 2, Songshan Lake Sci&Tech, Industry Park, Dongguan City, Guangdong Province, China, 523808

Tel: +86-0769-38826678, <http://www.dgddt.com>, Email: ddt@dgddt.com

CNAS Accreditation No. L6451; A2LA Accreditation No. 3870.01

Designation Number: CN1182; Test Firm Registration Number: 540522

Industry Canada site registration number: 10288A-1

2.8. Measurement uncertainty

Test Item	Uncertainty
Bandwidth	1.1%
Peak Output Power (Conducted) (Spectrum analyzer)	0.86dB (10 MHz ≤ f < 3.6GHz); 1.38dB (3.6GHz ≤ f < 8GHz)
Peak Output Power (Conducted) (Power Sensor)	0.74dB
Power Spectral Density	0.74dB (10 MHz ≤ f < 3.6GHz); 1.38dB (3.6GHz ≤ f < 8GHz)
Frequencies Stability	6.7 × 10 ⁻⁸ (Antenna couple method) 5.5 × 10 ⁻⁸ (Conducted method)
Conducted spurious emissions	0.86dB (10 MHz ≤ f < 3.6GHz); 1.40dB (3.6GHz ≤ f < 8GHz) 1.66dB (8GHz ≤ f < 22GHz)
Uncertainty for radio frequency (RBW < 20kHz)	3 × 10 ⁻⁸
Temperature	0.4°C
Humidity	2%
Uncertainty for Radiation Emission test (30MHz-1GHz)	4.70 dB (Antenna Polarize: V) 4.84 dB (Antenna Polarize: H)
Uncertainty for Radiation Emission test (1GHz-40GHz)	4.10dB (1-6GHz) 4.40dB (6GHz-18GHz) 3.54dB (18GHz-26GHz) 4.30dB (26GHz-40GHz)
Uncertainty for Power line conduction emission test	3.32dB (150kHz-30MHz)

Note: This uncertainty represents an expanded uncertainty expressed at approximately the 95% confidence level using a coverage factor of k=2.

3. Equipment used during test

Equipment	Manufacturer	Model No.	Serial No.	Last Cal.	Cal. Interval
RF Connected Test (Tonscend RF Measurement System)					
Spectrum analyzer	R&S	FSU26	200071	Oct. 12, 2018	1 Year
Wideband Radio Communication tester	R&S	CMW500	117491	Jun. 29, 2018	1 Year
Vector Signal Generator	Agilent	E8267D	US49060192	Oct. 12, 2018	1 Year
Vector Signal Generator	Agilent	N5182A	MY48180737	Jun. 29, 2018	1 Year
Power Sensor	Agilent	U2021XA	MY55150010	Oct. 21, 2018	1 Year
Power Sensor	Agilent	U2021XA	MY55150011	Oct. 23, 2018	1 Year
DC Power Source	MATRIS	MPS-3005L-3	D813058W	Aug. 18, 2018	1 Year
Attenuator	Mini-Circuits	BW-S10W2	101109	Aug. 18, 2018	1 Year
RF Cable	Micable	C10-01-01-1	100309	Oct. 21, 2018	1 Year
Temp&Humi Programmable	ZHIXIANG	ZXGDJS-150L	ZX170110-A	Oct. 21, 2018	1 Year
Test Software	JS Tonscend	JS1120-3	Ver.2.7	N/A	N/A
Radiation 1#chamber					
EMI Test Receiver	R&S	ESU8	100316	Oct. 12, 2018	1 Year
Spectrum analyzer	Agilent	E4447A	MY50180031	Jun. 29, 2018	1 Year
Trilog Broadband Antenna	Schwarzbeck	VULB9163	9163-462	Nov. 09, 2018	1 Year
Active Loop antenna	Schwarzbeck	FMZB-1519	1519-038	Oct. 20, 2018	1 Year
Double Ridged Horn Antenna	R&S	HF907	100276	Nov. 16, 2018	1 Year
Broad Band Horn Antenna	Schwarzbeck	BBHA 9170	790	Oct. 25, 2018	1 Year
Pre-amplifier	A.H.	PAM-0118	360	Oct. 12, 2018	1 Year
Pre-amplifier	TERA-MW	TRLA-0040 G35	101303	Oct. 12, 2018	1 Year
RF Cable	HUBSER	CP-X2+ CP-X1	W11.03+ W12.02	Oct. 21, 2018	1 Year
RF Cable	N/A	SMAJ-SMA J-1M+ 11M	17070133+17070131	Nov. 08, 2018	1 Year
MI Cable	HUBSER	C10-01-01-1 M	1091629	Oct. 21, 2018	1 Year
Test software	Audix	E3	V 6.11111b	N/A	N/A
Power Line Conducted Emissions Test					
EMI Test Receiver	R&S	ESU8	100316	Oct. 21, 2018	1 Year
LISN 1	R&S	ENV216	101109	Oct. 21, 2018	1 Year
LISN 2	R&S	ESH2-Z5	100309	Oct. 21, 2018	1 Year
Pulse Limiter	R&S	ESH3-Z2	101242	Oct. 21, 2018	1 Year
CE Cable 1	HUBSER	N/A	W10.01	Oct. 21, 2018	1 Year
Test software	Audix	E3	V 6.11111b	N/A	N/A

4. 26dB Bandwidth, 6dB Bandwidth and 99% Bandwidth

4.1. Block diagram of test setup

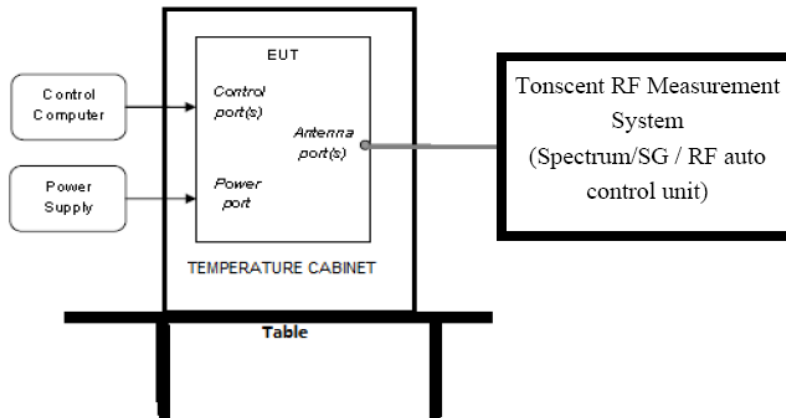

4.2. Limits

FCC Part15, Subpart E/ RSS-247		
Test Item	Limit	Frequency Range (MHz)
Bandwidth	26 dB Bandwidth	5150-5250
	26 dB Bandwidth	5250-5350
	26 dB Bandwidth	For FCC:5470-5725 For IC:5470-5600 5650-5725
	Minimum 500kHz 6dB Bandwidth	5725-5850

4.3. Test Procedure

(1) Connect EUT's antenna output to spectrum analyzer by RF cable.

Center Frequency	The centre frequency of the channel under test
Detector	Peak
RBW	For 6dB Bandwidth: RBW=100kHz For 26dB Bandwidth: approximately 1% of the emission bandwidth.
VBW	For 6dB Bandwidth: VBW=300kHz For 26dB Bandwidth: >3RBW
Trace	Max hold
Sweep	Auto couple

(2) Allow the trace to stabilize, measure the maximum width of the emission that is constrained by the frequencies associated with the two outermost amplitude points (upper and lower frequencies) that are attenuated by 26 dB and 6dB relative to the maximum level measured in the fundamental emission.

4.4. Test Result

Test Mode	Antenna	Channel	99% BW[MHz]	EBW[MHz]	Limit [MHz]	Verdict
$\pi/4$ -DQPSK	ANT1	5736.35	4.615	3.478	0.5	PASS
$\pi/4$ -DQPSK	ANT1	5776.35	4.663	3.510	0.5	PASS
$\pi/4$ -DQPSK	ANT1	5820.35	4.679	3.526	0.5	PASS

4.5. Original test data

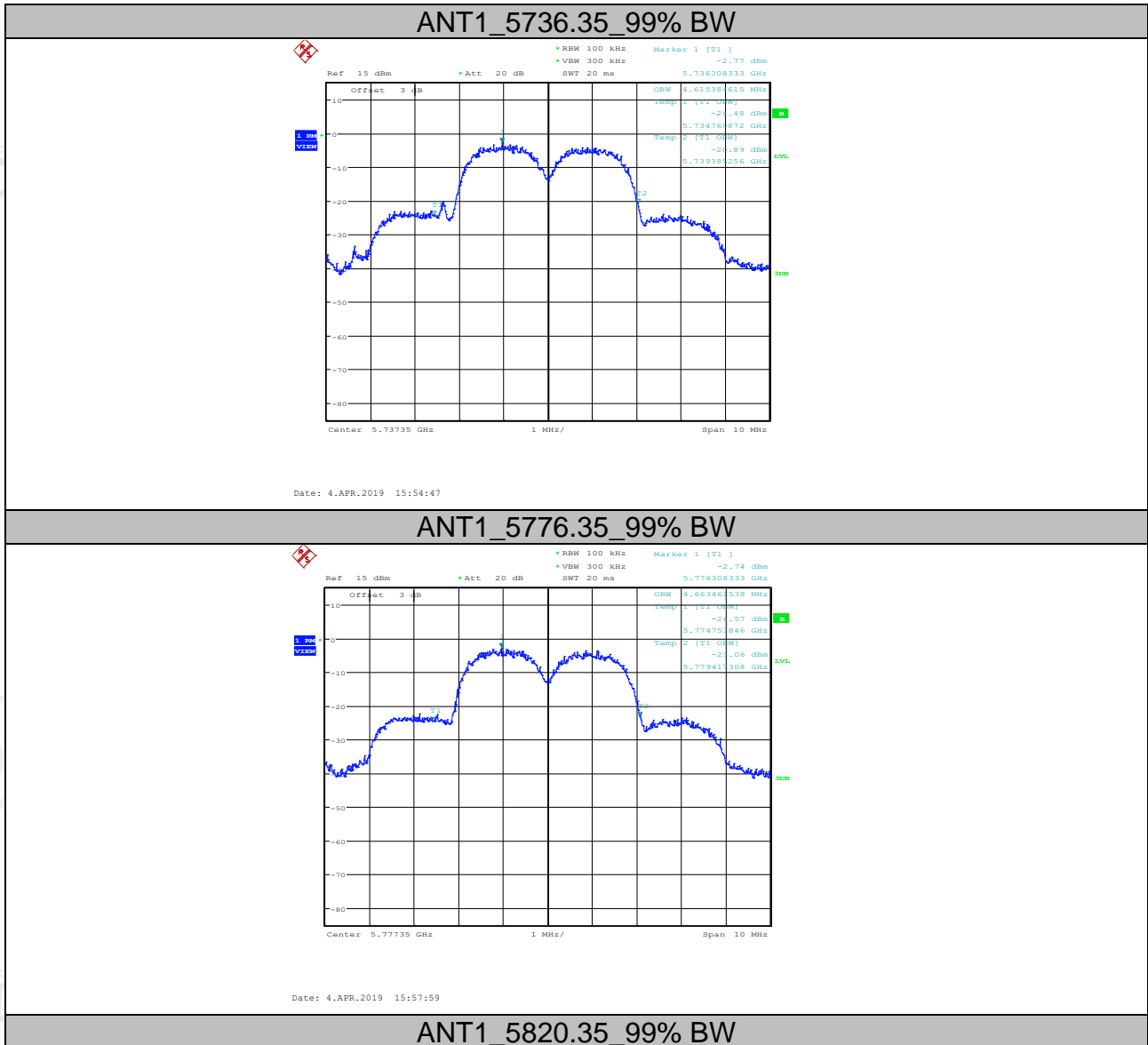

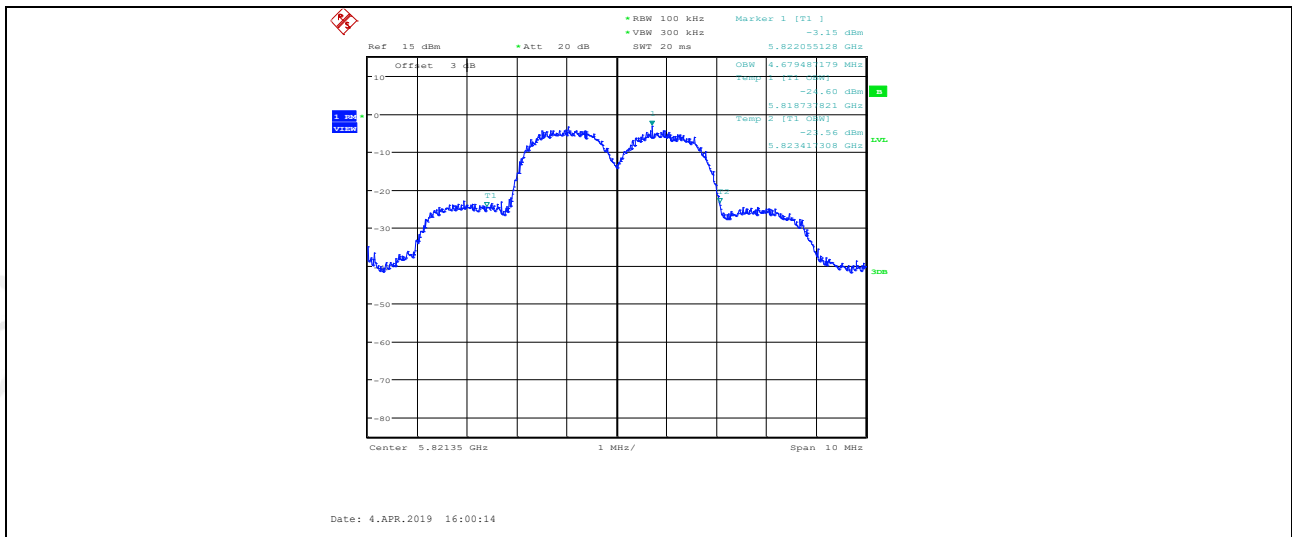

ANT1_5736.35_EBW

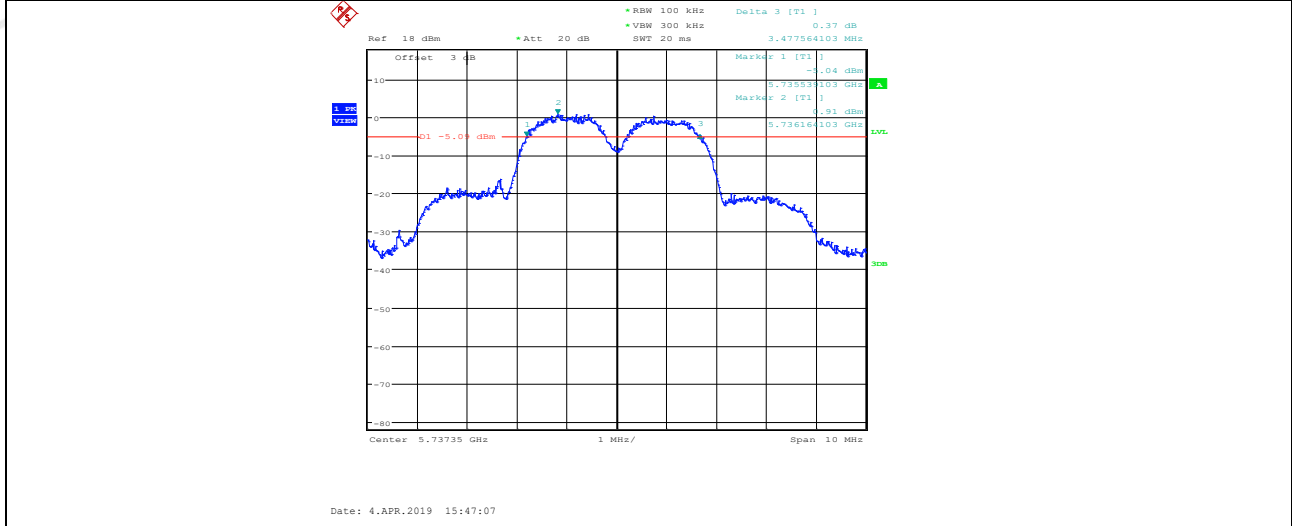

ANT1_5776.35_EBW

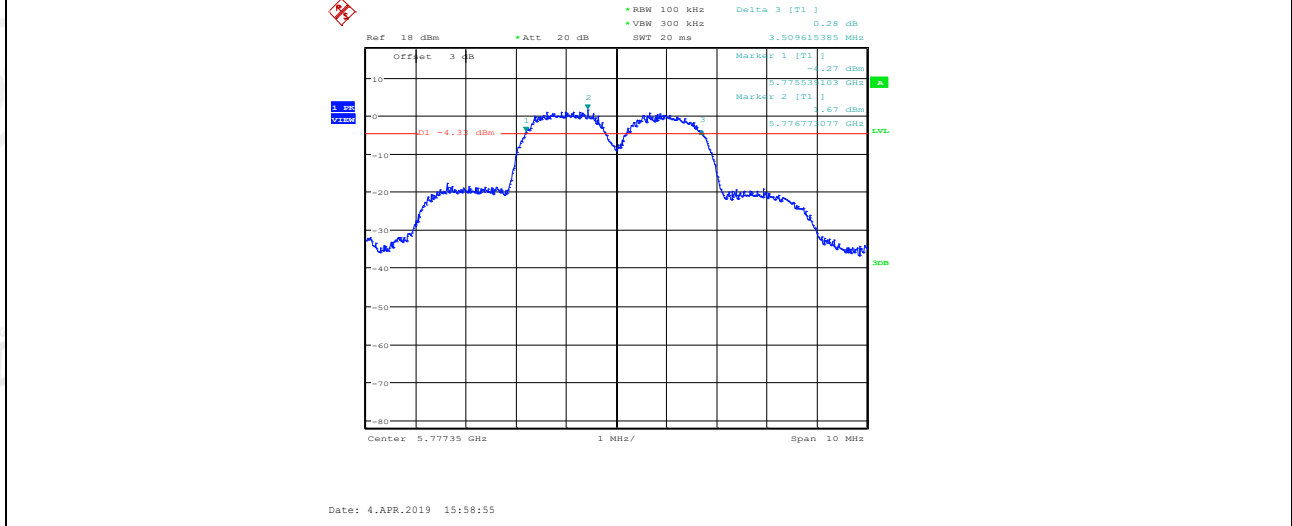

ANT1_5820.35_EBW

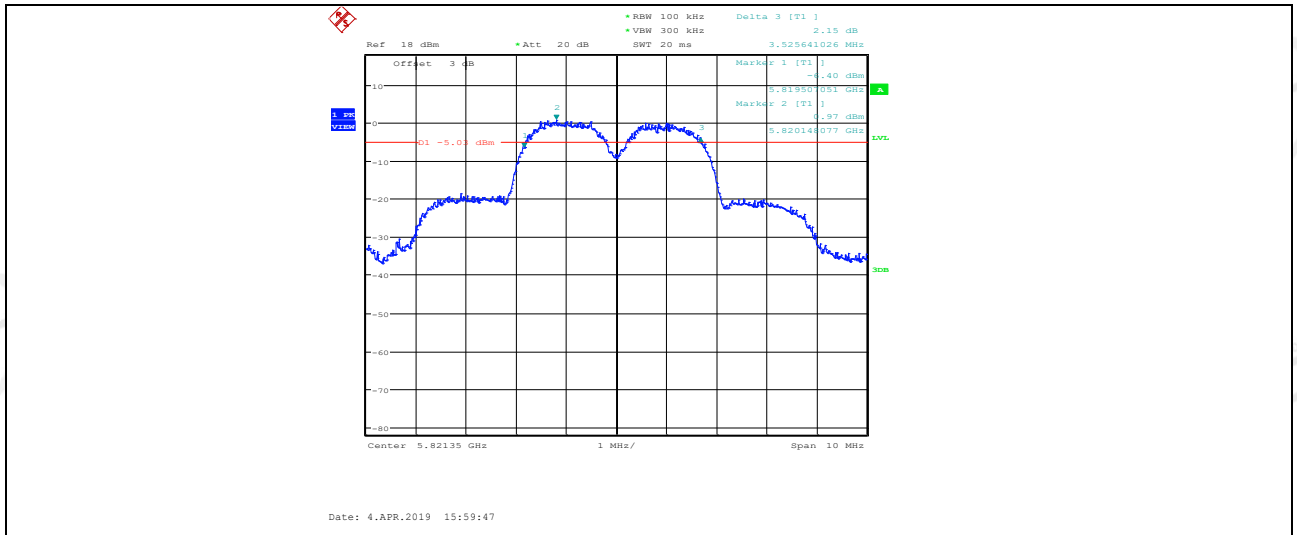

5. Maximum Output Power

5.1. Block diagram of test setup

Same as section 4.1

5.2. Limits

FCC Part15, Subpart E/ RSS-247		
Test Item	Limit	Frequency Range (MHz)
Conducted Output Power	For FCC client devices: 250mW (24dBm)	5150-5250
	For RSS: e.i.r.p. power: not exceed 200 mW(23dBm) or $10 + 10 \log_{10} B$	
	250mW (24dBm) or $11 + 10 \log_{10} B$	5250-5350
	250mW (24dBm) or $11 + 10 \log_{10} B$	For FCC:5470-5725 For IC:5470-5600 5650-5725
	1 Watt (30dBm)	5725-5850

Note: For ISED: B=99% bandwidth.

5.3. Test Procedure

Connect each EUT's antenna output to Spectrum Analyzer by RF cable and attenuator

5.4. Test Result

Test Mode	Test Channel	Ant	Power Level [dBm]	Limit [dBm]	Verdict
$\pi/4$ -DQPSK	5736.35	ANT1	4.51	30	PASS
$\pi/4$ -DQPSK	5776.35	ANT1	4.93	30	PASS
$\pi/4$ -DQPSK	5820.35	ANT1	4.30	30	PASS

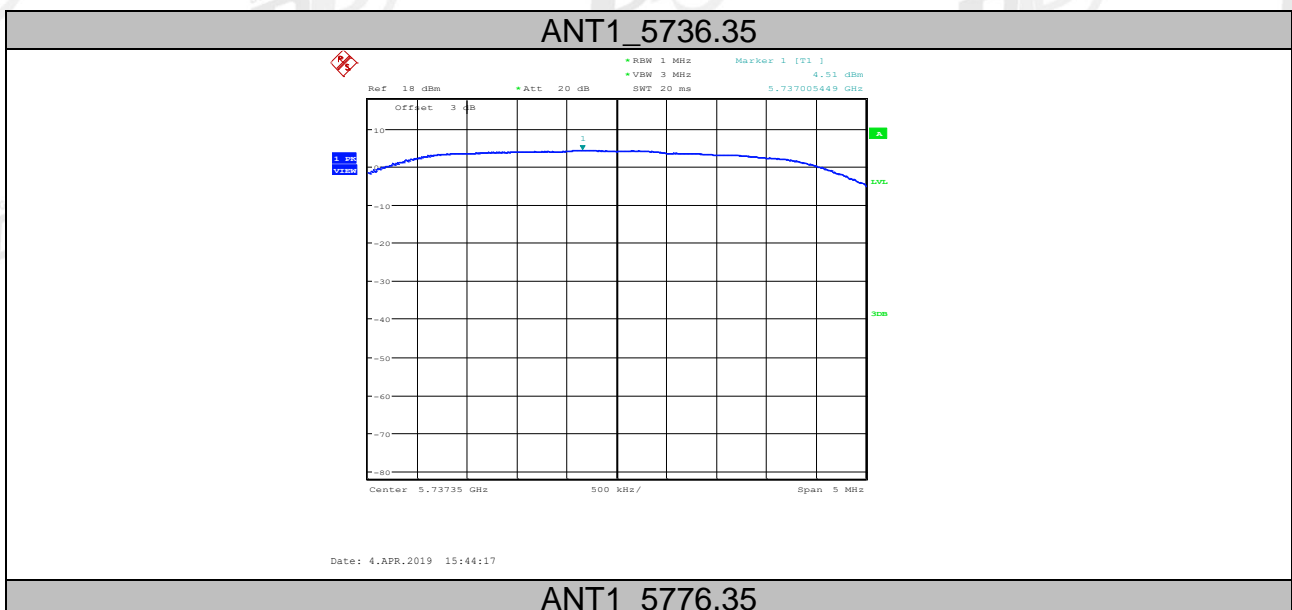

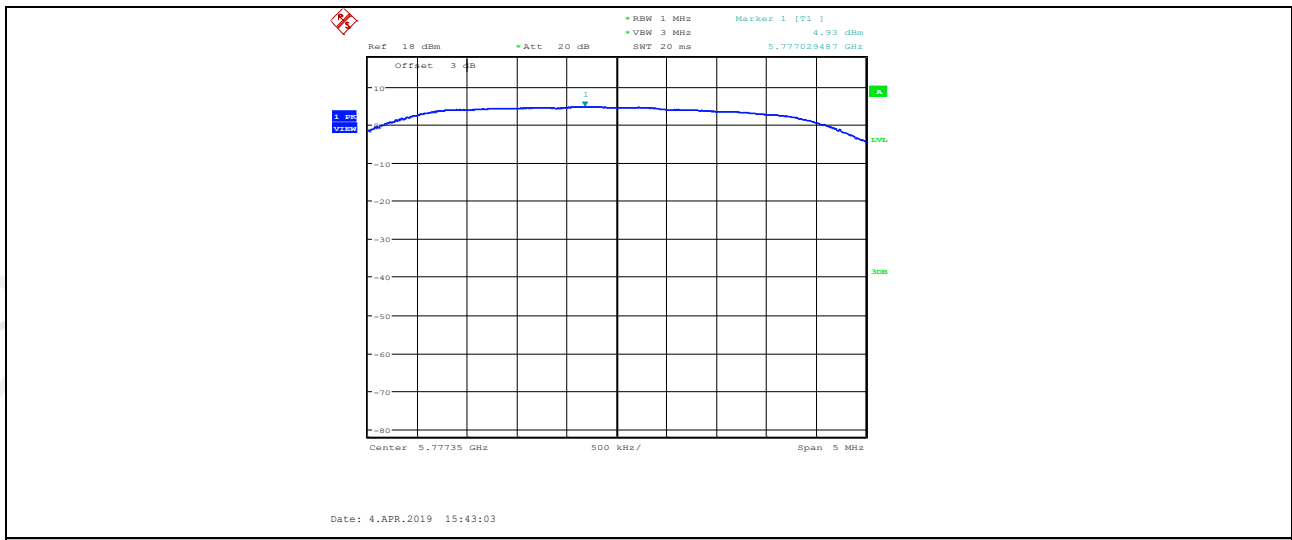

ANT1_5820.35

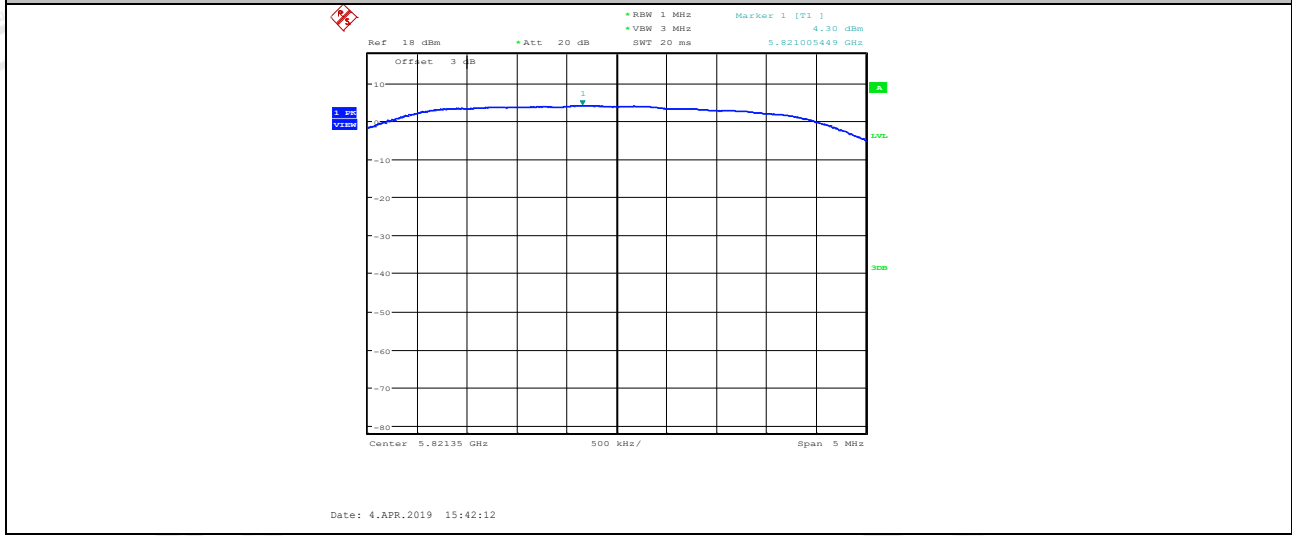

6. Power Spectral Density

6.1. Block diagram of test setup

Same with 4.1

6.2. Limits

FCC Part15, Subpart E/ RSS-247		
Test Item	Limit	Frequency Range (MHz)
Power Spectral Density	For FCC: Other than Mobile and portable:17dBm/MHz Mobile and portable:11dBm/MHz	5150-5250
	For RSS eirp:10dBm/MHz	
	11dBm/MHz	5250-5350
	11dBm/MHz	For FCC:5470-5725 For IC:5470-5600 5650-5725
	30dBm/500kHz	5725-5850

6.3. Test Procedure

The transmitter output was connected to a spectrum analyzer. Power density was measured by spectrum analyzer with 1MHz RBW and 3MHz VBW.

Connect the UUT to the spectrum analyser and use the following settings:

5150MHz~5250MHz, 5250MHz~5350MHz, 5470MHz~5725MHz

Center Frequency	The centre frequency of the channel under test
Detector	RMS
RBW	1MHz
VBW	$\geq 3 \times \text{RBW}$
Span	Encompass the entire emissions bandwidth (EBW) of the signal
Trace	Max hold
Sweep time	Auto

5725MHz-5850MHz

Center Frequency	The centre frequency of the channel under test
Detector	RMS
RBW	500kHz
VBW	$\geq 3 \times \text{RBW}$
Span	Encompass the entire emissions bandwidth (EBW) of the signal
Trace	Max hold
Sweep time	Auto

Note:

1. For UNII-3, according to KDB publication 789033 D02 General U-NII Test Procedures New Rules v02r01, section II.F.5., it is acceptable to set RBW at 1MHz and VBW at 3MHz if the spectrum analyzer does not have 500kHz RBW.

2. The value measured with RBW=1MHz is to be added with $10\log(500\text{kHz}/1\text{MHz})$ which is -3dB. For example, if the measured value is +10dBm using RBW=1MHz (that is +10dBm/MHz), then the converted value will be +7dBm/500kHz.

Allow trace to fully stabilize and use the peak marker function to determine the maximum amplitude level within the RBW.

6.4. Test Result

Test Mode	Test Channel	Ant	Level [dBm/500kHz]	10log(1/x) Factor[dB]	10log (500kHz/RBW) Factor [dB]	PSD [dBm/500kHz]	Limit [dBm/500kHz]	Verdict
$\pi/4$ -DQPSK	5736.35	Ant1	0.84	0	0	0.84	30.00	PASS
$\pi/4$ -DQPSK	5776.35	Ant1	1.27	0	0	1.27	30.00	PASS
$\pi/4$ -DQPSK	5820.35	Ant1	0.74	0	0	0.74	30.00	PASS

6.5. Original test data

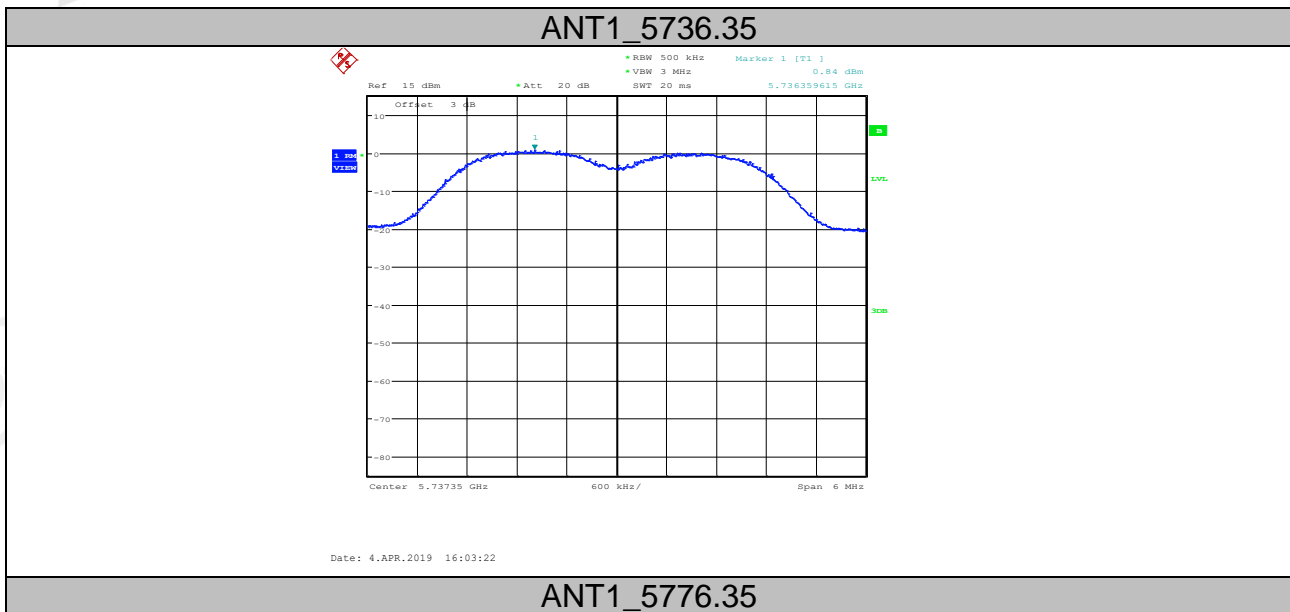

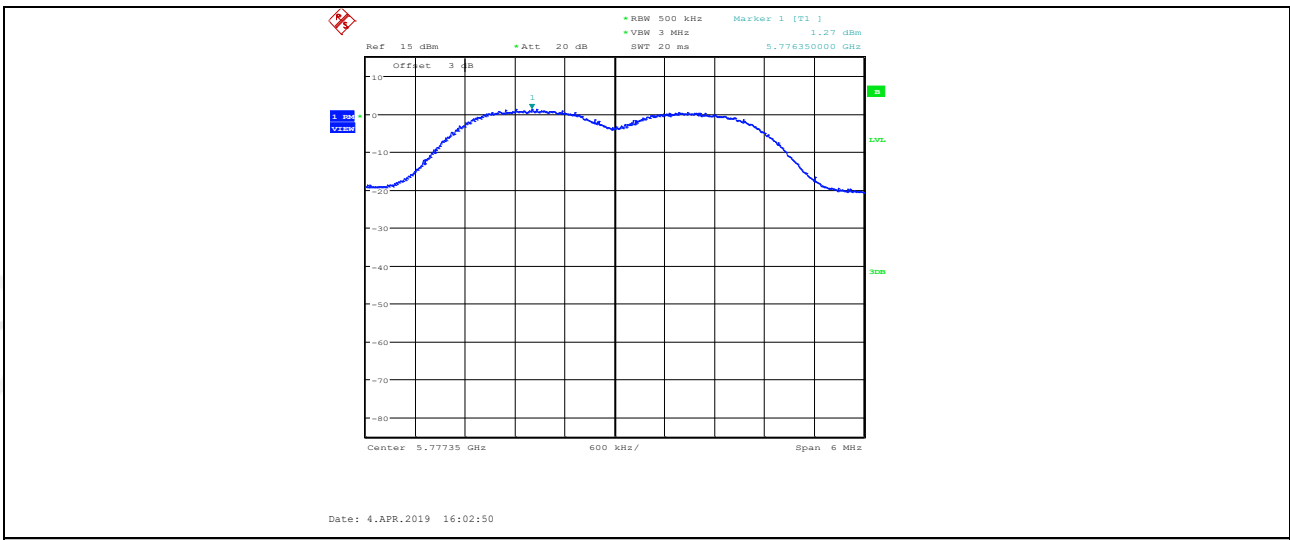

ANT1_5820.35

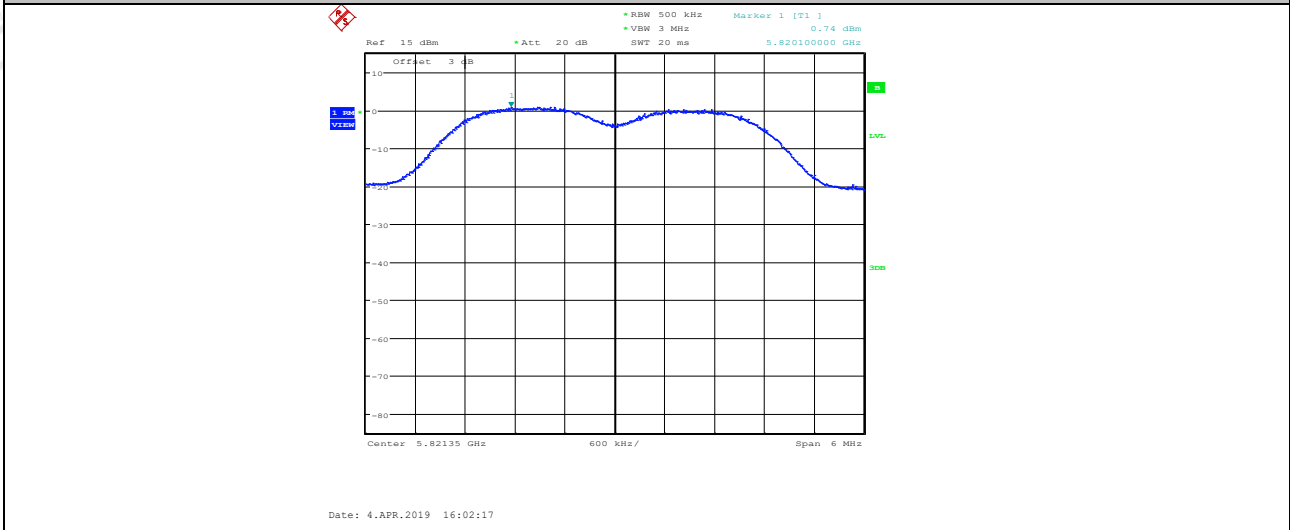

7. Frequency Stability Measurement

7.1. Limit of Frequency Stability

Manufacturers of U-NII devices are responsible for ensuring frequency stability such that an emission is maintained within the band of operation under all conditions of normal operation as specified in the user's manual.

7.2. Measuring Instruments

The measuring equipment is listed in the section 4 of this test report.

7.3. Test Procedures

(1) To ensure emission at the band edge is maintained within the authorized band, those values shall be measured by radiation emissions at upper and lower frequency points, and finally compensated by frequency deviation as procedures below.

(2) The EUT was operated at the maximum output power, and connected to the spectrum analyzer, which is set to maximum hold function and peak detector. The peak value of the power envelope was measured and noted. The upper and lower frequency points were respectively measured relatively 10dB lower than the measured peak value.

(3) The frequency deviation was calculated by adding the upper frequency point and the lower frequency point divided by two. Those detailed values of frequency deviation are provided in table below.

7.4. Test Setup

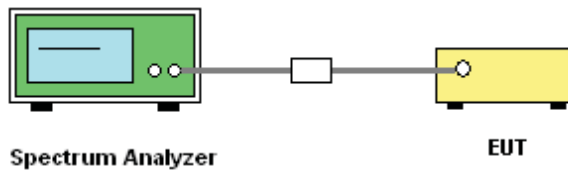

7.5. Test Result

Voltage								
Test Mode	Antenna	Channel	Voltage [Vdc]	Temperature (°C)	Deviation (kHz)	Deviation (ppm)	Limit (ppm)	Verdict
Single Carrier	ANT1	5736.35	NV	NT	-19	-3.28	20	PASS
Single Carrier	ANT1	5736.35	LV	NT	-21	-3.66	20	PASS
Single Carrier	ANT1	5736.35	HV	NT	-21	-3.66	20	PASS
Single Carrier	ANT1	5776.35	NV	NT	-25	-4.33	20	PASS
Single Carrier	ANT1	5776.35	LV	NT	-26	-4.50	20	PASS
Single Carrier	ANT1	5776.35	HV	NT	-26	-4.50	20	PASS
Single Carrier	ANT1	5820.35	NV	NT	-24	-4.12	20	PASS
Single Carrier	ANT1	5820.35	LV	NT	-24	-4.12	20	PASS
Single Carrier	ANT1	5820.35	HV	NT	-24	-4.12	20	PASS

Temperature								
Test Mode	Antenna	Channel	Voltage [Vdc]	Temperature (°C)	Deviation (kHz)	Deviation (ppm)	Limit (ppm)	Verdict
Single Carrier	ANT1	5736.35	NV	-30	-21	-3.66	20	PASS

Single Carrier	ANT1	5736.35	NV	-20	-21	-3.66	20	PASS
Single Carrier	ANT1	5736.35	NV	-10	-21	-3.66	20	PASS
Single Carrier	ANT1	5736.35	NV	0	-21	-3.66	20	PASS
Single Carrier	ANT1	5736.35	NV	10	-21	-3.66	20	PASS
Single Carrier	ANT1	5736.35	NV	20	-21	-3.66	20	PASS
Single Carrier	ANT1	5736.35	NV	30	-21	-3.66	20	PASS
Single Carrier	ANT1	5736.35	NV	40	-21	-3.66	20	PASS
Single Carrier	ANT1	5736.35	NV	50	-21	-3.66	20	PASS
Single Carrier	ANT1	5776.35	NV	-30	-26	-4.50	20	PASS
Single Carrier	ANT1	5776.35	NV	-20	-26	-4.50	20	PASS
Single Carrier	ANT1	5776.35	NV	-10	-26	-4.50	20	PASS
Single Carrier	ANT1	5776.35	NV	0	-26	-4.50	20	PASS
Single Carrier	ANT1	5776.35	NV	10	-26	-4.50	20	PASS
Single Carrier	ANT1	5776.35	NV	20	-26	-4.50	20	PASS
Single Carrier	ANT1	5776.35	NV	30	-26	-4.50	20	PASS
Single Carrier	ANT1	5776.35	NV	40	-26	-4.50	20	PASS
Single Carrier	ANT1	5776.35	NV	50	-26	-4.50	20	PASS
Single Carrier	ANT1	5820.35	NV	-30	-24	-4.12	20	PASS
Single Carrier	ANT1	5820.35	NV	-20	-24	-4.12	20	PASS
Single Carrier	ANT1	5820.35	NV	-10	-24	-4.12	20	PASS
Single Carrier	ANT1	5820.35	NV	0	-24	-4.12	20	PASS
Single Carrier	ANT1	5820.35	NV	10	-24	-4.12	20	PASS
Single Carrier	ANT1	5820.35	NV	20	-24	-4.12	20	PASS
Single Carrier	ANT1	5820.35	NV	30	-24	-4.12	20	PASS
Single Carrier	ANT1	5820.35	NV	40	-24	-4.12	20	PASS
Single Carrier	ANT1	5820.35	NV	50	-24	-4.12	20	PASS

8. Emissions in restricted frequency bands

8.1. Block diagram of test setup

In 3m Anechoic Chamber Test Setup Diagram for 9kHz-30MHz

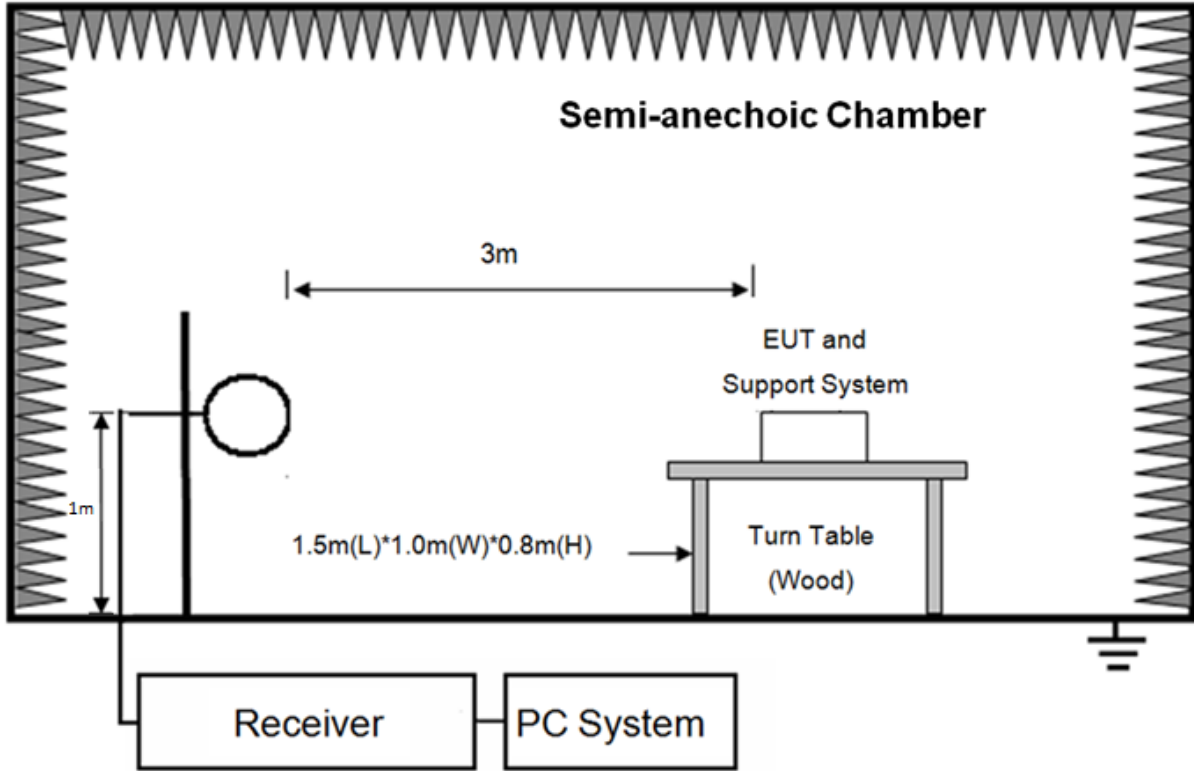

In 3m Anechoic Chamber Test Setup Diagram for 30MHz-1GHz

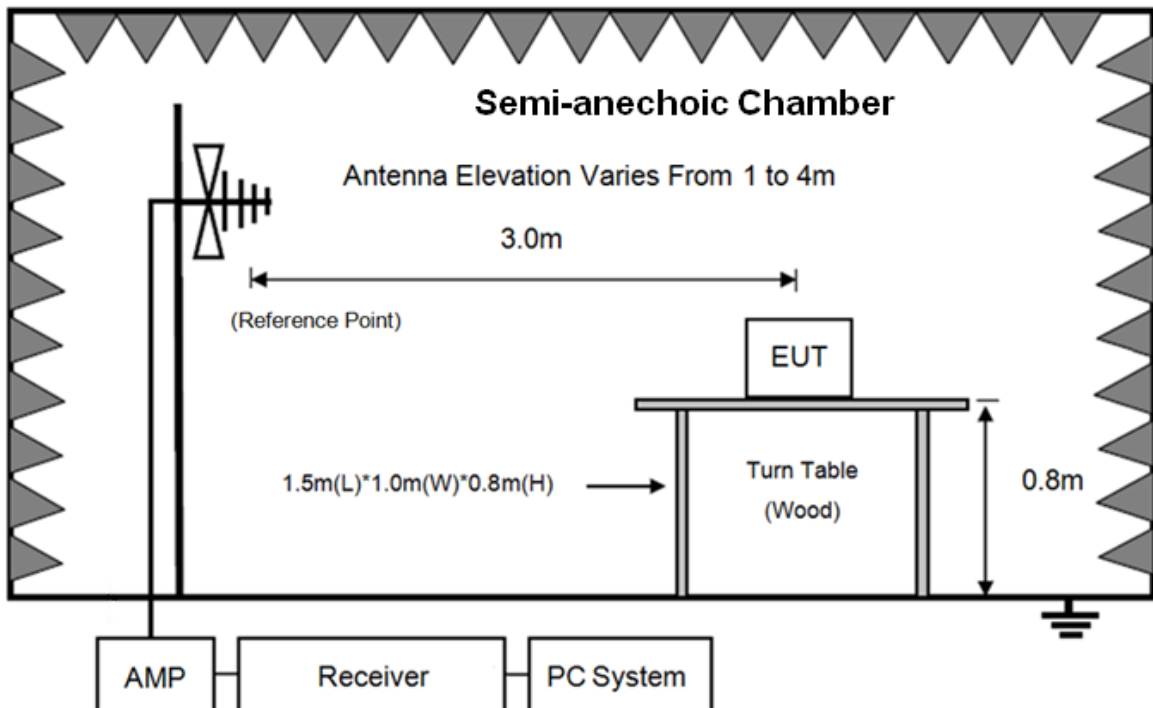

In 3m Anechoic Chamber Test Setup Diagram for frequency above 1GHz

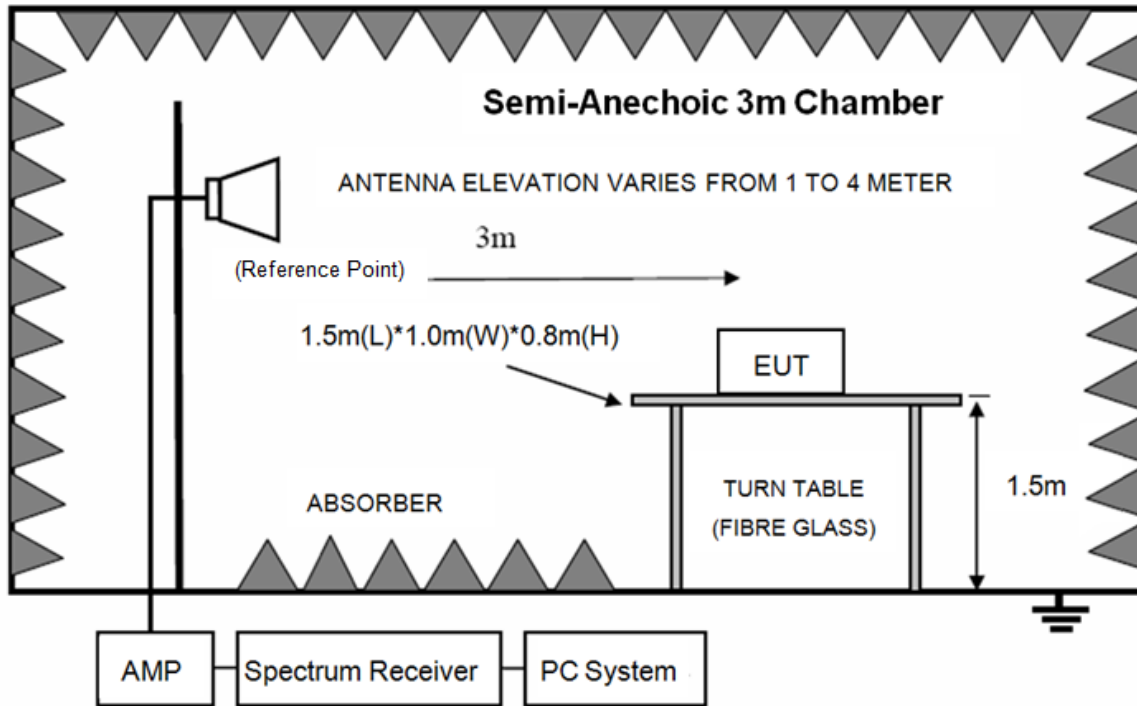

Note: For harmonic emissions test an appropriate high pass filter was inserted in the input port of AMP.

8.2. Limit

8.3.1 FCC 15.205 Restricted frequency band

MHz	MHz	MHz	GHz
0.090-0.110	16.42-16.423	399.9-410	4.5-5.15
10.495-0.505	16.69475-16.69525	608-614	5.35-5.46
2.1735-2.1905	16.80425-16.80475	960-1240	7.25-7.75
4.125-4.128	25.5-25.67	1300-1427	8.025-8.5
4.1772&4.17775	37.5-38.25	1435-1626.5	9.0-9.2
4.2072&4.20775	73-74.6	1645.5-1646.5	9.3-9.5
6.215-6.218	74.8-75.2	1660-1710	10.6-12.7
6.26775-6.26825	108-121.94	1718.8-1722.2	13.25-13.4
6.31175-6.31225	123-138	2200-2300	14.47-14.5
8.291-8.294	149.9-150.05	2310-2390	15.35-16.2
8.362-8.366	156.52475-156.52525	2483.5-2500	17.7-21.4
8.37625-8.38675	156.7-156.9	2690-2900	22.01-23.12
8.41425-8.41475	162.0125-167.17	3260-3267	23.6-24.0
12.29-12.293	167.72-173.2	3332-3339	31.2-31.8
12.51975-12.52025	240-285	3345.8-3358	36.43-36.5
12.57675-12.57725	322-335.4	3600-4400	(²)
13.36-13.41			

8.3.2 FCC 15.209 Limit.

FREQUENCY MHz	DISTANCE Meters	FIELD STRENGTHS LIMIT	
		$\mu\text{V}/\text{m}$	$\text{dB}(\mu\text{V})/\text{m}$
0.009 ~ 0.490	300	2400/F(kHz)	67.6-20log(F)
0.490 ~ 1.705	30	24000/F(kHz)	87.6-20log(F)
1.705 ~ 30.0	30	30	29.54
30 ~ 88	3	100	40.0
88 ~ 216	3	150	43.5
216 ~ 960	3	200	46.0
960 ~ 1000	3	500	54.0
Above 1000	3	74.0 $\text{dB}(\mu\text{V})/\text{m}$ (Peak) 54.0 $\text{dB}(\mu\text{V})/\text{m}$ (Average)	

Note: (1) The emission limits shown in the above table are based on measurements employing a CISPR QP detector except for the frequency bands 9-90kHz, 110-490kHz and above 1000MHz. Radiated emissions limits in these three bands are based on measurements employing an average detector.

(2) At frequencies below 30MHz, measurement may be performed at a distance closer than that specified, and the limit at closer measurement distance can be extrapolated by below formula:

$$\text{Limit}_{3\text{m}}(\text{dB}\mu\text{V}/\text{m}) = \text{Limit}_{30\text{m}}(\text{dB}\mu\text{V}/\text{m}) + 40\text{Log}(30\text{m}/3\text{m})$$

8.3.3 Limit for this EUT

All the emissions appearing within 15.205 restricted frequency bands shall not exceed the limits shown in 15.209, all the other emissions shall be at least 20dB below the fundamental emissions or comply with 15.209 limits.

8.3. Test Procedure

- (1) EUT height should be 0.8m for below 1GHz at a semi - anechoic chamber while EUT height should be 1.5m for above 1GHz at full chamber or semi - anechoic chamber ground with absorbers
- (2) Setup EUT and assistant system according clause 2.3 and 8.2
- (3) Test antenna was located 3m from the EUT on an adjustable mast, and the antenna used as below table.

Test frequency range	Test antenna used	Test distance
9kHz-30MHz	Active Loop antenna	3m
30MHz-1GHz	Trilog Broadband Antenna	3m
1GHz-18GHz	Double Ridged Horn Antenna(1GHz-18GHz)	3m
18GHz-40GHz	Horn Antenna(18GHz-40GHz)	1m

According ANSI C63.10:2013 clause 6.4.4.2 and 6.5.3, for measurements below 30 MHz, the loop antenna was positioned with its plane vertical from the EUT and rotated about its vertical axis for maximum response at each azimuth position around the EUT. And the loop antenna also be positioned with its plane horizontal at the specified distance from the EUT. The center of the loop is 1 m above the ground. for measurement above 30MHz, the Trilog Broadband Antenna or Horn Antenna was located

3m from EUT, Measurements were made with the antenna positioned in both the horizontal and vertical planes of Polarization, and the measurement antenna was varied from 1 m to 4 m. in height above the reference ground plane to obtain the maximum signal strength.

(4) Below pre-scan procedure was first performed in order to find prominent frequency spectrum radiated emissions from 9kHz to 40GHz:

(a) Scanning the peak frequency spectrum with the antenna specified in step (3), and the EUT was rotated 360 degree, the antenna height was varied from 1m to 4m (Except loop antenna, it's fixed 1m above ground.)

(b) Change work frequency or channel of device if practicable.

(c) Change modulation type of device if practicable.

(d) Change power supply range from 85% to 115% of the rated supply voltage

(e) Rotated EUT though three orthogonal axes to determine the attitude of EUT arrangement produces highest emissions.

Spectrum frequency from 9kHz to 40GHz (tenth harmonic of fundamental frequency) was investigated, and no any obvious emission were detected from 9kHz to 30MHz and 18GHz to 40GHz, so below final test was performed with frequency range from 30MHz to 18GHz.

(5) For final emissions measurements at each frequency of interest, the EUT was rotated and the antenna height was varied between 1m and 4m in order to maximize the emission. Measurements in both horizontal and vertical polarities were made and the data was recorded. In order to find the maximum emission, the relative positions of equipment and all of the interface cables were changed according to ANSI C63.10:2013 on Radiated Emission test.

(6) The emissions from 9kHz to 1GHz were measured based on CISPR QP detector except for the frequency bands 9-90kHz, 110-490kHz, for emissions from 9kHz-90kHz,110kHz-490kHz and above 1GHz were measured based on average detector, for emissions above 1GHz, peak emissions also be measured and need comply with Peak limit.

(7) The emissions from 9kHz to 1GHz, QP or average values were measured with EMI receiver with below RBW

Frequency band	RBW
9kHz-150kHz	200Hz
150kHz-30MHz	9kHz
30MHz-1GHz	120kHz

(8) For emissions above 1GHz, both Peak and Average level were measured with Spectrum Analyzer, and the RBW is set at 1MHz, VBW is set at 3MHz, Peak detector for Peak measure, RMS detector for AV value

8.4. Test result

PASS. (See below detailed test result)

All the emissions except fundamental emission from 9kHz to 40GHz were comply with 15.209 limit.

Note1: According exploratory test no any obvious emission was detected from 9kHz to 30MHz and 18GHz to 40GHz, so the final test was performed with frequency range from 30MHz to 18GHz and recorded in below.

Note2: For emissions below 1GHz, according exploratory explorer test, when change Tx mode and channel, have no distinct influence on emissions level, so for emissions below 1GHz, the final test was only performed with EUT working in 5776.35MHz.

Radiated Emission test (below 1GHz)

TR-4-E-009 Radiated Emission Test Result

Test Site : DDT 3m Chamber 1#
 Test Date : 2019-04-02
 EUT : SOUNDBAR
 Power Supply : AC 230V
 Condition : Temp:24.5°C,Humi:55%,Press:100.1kPa
 Memo : SRD

D:\2018 RE1# Report Data\Q18112313-1E Bar2.1 Deep Bass CNTR INPUT\FCC BELOW1G.EM6
 Tested By : Talent
 Model Number : Bar 2.1 Deep Bass CNTR
 Test Mode : TX mode
 Antenna/Distance : 2018 VULB 9163 1#/3m/HORIZONTAL

Data: 6

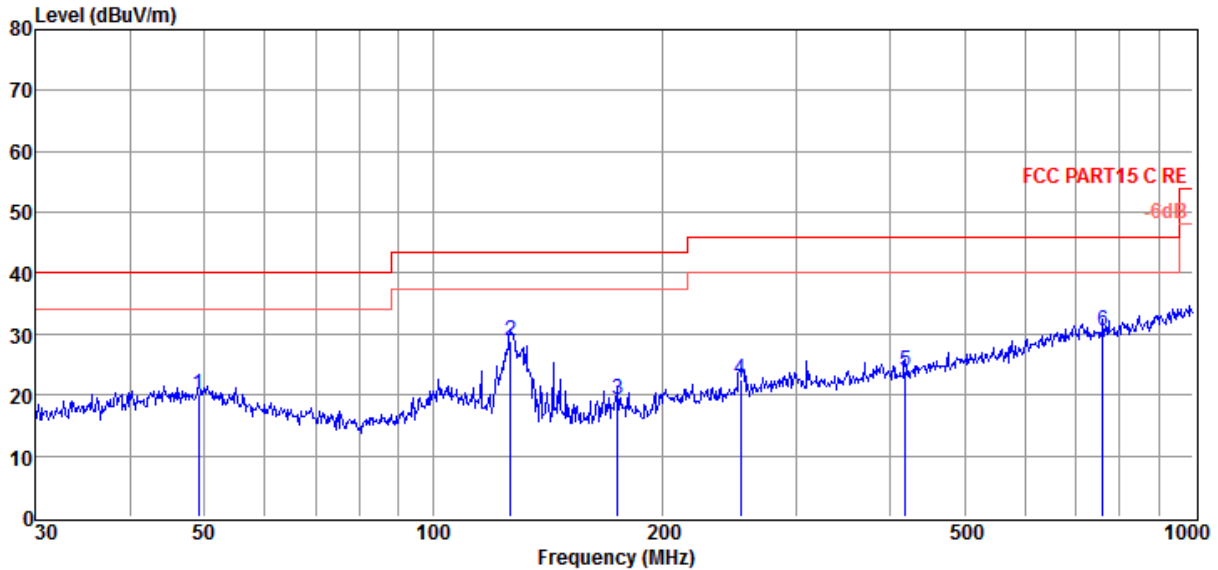

Item (Mark)	Freq. (MHz)	Read Level (dBμV)	Antenna Factor (dB/m)	Cable Loss (dB)	Result Level (dBμV/m)	Limit Line (dBμV/m)	Over Limit (dB)	Detector	Polarization
1	49.19	1.83	14.51	3.86	20.20	40.00	-19.80	QP	HORIZONTAL
2	126.33	14.91	9.57	4.33	28.81	43.50	-14.69	QP	HORIZONTAL
3	175.04	5.11	9.31	4.70	19.12	43.50	-24.38	QP	HORIZONTAL
4	253.84	4.49	12.93	5.02	22.44	46.00	-23.56	QP	HORIZONTAL
5	417.64	2.49	15.89	5.57	23.95	46.00	-22.05	QP	HORIZONTAL
6	760.70	3.44	20.47	6.52	30.43	46.00	-15.57	QP	HORIZONTAL

- Note: 1. Result Level = Read Level + Antenna Factor + Cable loss.
 2. If Peak Result complies with QP limit, QP Result is deemed to comply with QP limit.
 3. Test setup: RBW: 120 kHz, VBW: 300 kHz, Sweep time: auto.

TR-4-E-009 Radiated Emission Test Result

Test Site : DDT 3m Chamber 1#
Test Date : 2019-04-02
EUT : SOUNDBAR
Power Supply : AC 230V
Condition : Temp:24.5°C,Humi:55%,Press:100.1kPa
Memo : SRD

D:\2018 RE1# Report Data\Q18112313-1E Bar2.1 Deep Bass CNTR INPUT\FCC BELOW1G.EM6
Tested By : Talent
Model Number : Bar 2.1 Deep Bass CNTR
Test Mode : TX mode
Antenna/Distance : 2018 VULB 9163 1#/3m/VERTICAL

Data: 7

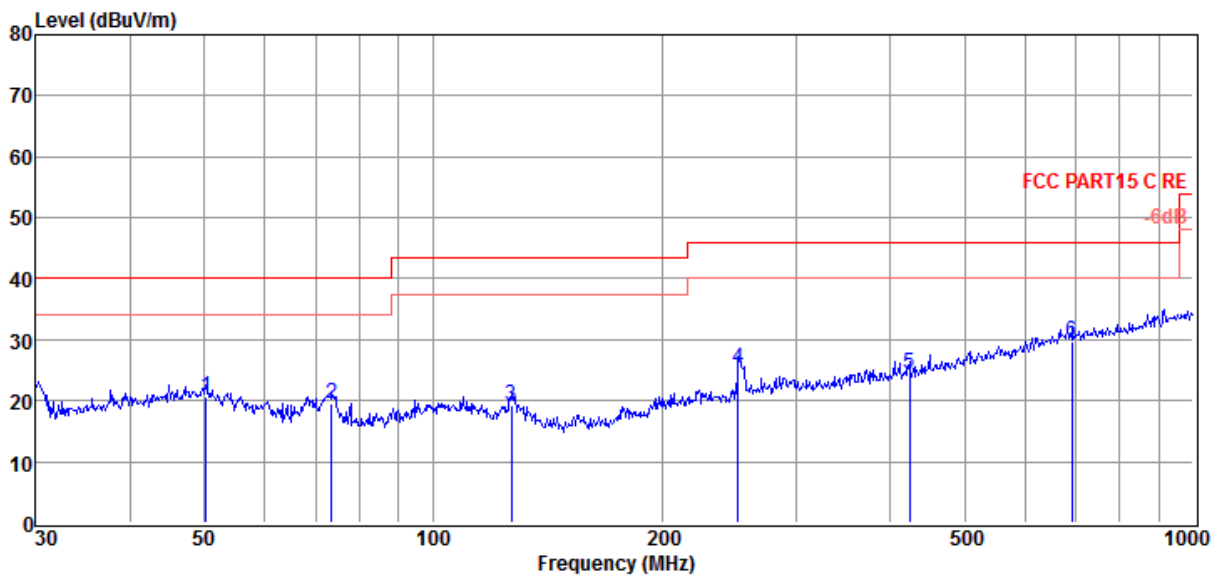

Item (Mark)	Freq. (MHz)	Read Level (dBμV)	Antenna Factor (dB/m)	Cable Loss (dB)	Result Level (dBμV/m)	Limit Line (dBμV/m)	Over Limit (dB)	Detector	Polarization
1	50.23	2.11	14.52	3.87	20.50	40.00	-19.50	QP	VERTICAL
2	73.62	6.11	9.27	4.04	19.42	40.00	-20.58	QP	VERTICAL
3	126.77	5.39	9.56	4.34	19.29	43.50	-24.21	QP	VERTICAL
4	252.06	7.39	12.88	5.01	25.28	46.00	-20.72	QP	VERTICAL
5	423.54	2.92	15.98	5.59	24.49	46.00	-21.51	QP	VERTICAL
6	691.99	3.44	19.98	6.35	29.77	46.00	-16.23	QP	VERTICAL

Note: 1. Result Level = Read Level + Antenna Factor + Cable loss.
 2. If Peak Result complies with QP limit, QP Result is deemed to comply with QP limit.
 3. Test setup: RBW: 120 kHz, VBW: 300 kHz, Sweep time: auto.

Radiated Emission test (above 1GHz)

Freq (MHz)	Read level (dBμV)	Antenna Factor (dB/m)	PRM Factor(dB)	Cable Loss (dB)	Result Level (dBμV/m)	Limit (dBμV/m)	Margin (dB)	Detector type	Polarization
5736.35 MHz									
4791.00	47.77	33.78	44.24	11.23	48.54	74.00	-25.46	Peak	HORIZONTAL
5641.00	48.67	34.42	44.07	11.19	50.21	74.00	-23.79	Peak	HORIZONTAL
6185.00	46.46	34.93	43.90	12.14	49.63	74.00	-24.37	Peak	HORIZONTAL
6933.00	47.37	35.56	43.55	12.43	51.81	74.00	-22.19	Peak	HORIZONTAL
7596.00	46.74	35.98	43.26	13.10	52.56	74.00	-21.44	Peak	HORIZONTAL
8446.00	45.82	36.75	43.34	13.79	53.02	74.00	-20.98	Peak	HORIZONTAL
4621.00	48.65	33.68	44.27	9.82	47.88	74.00	-26.12	Peak	VERTICAL
5029.00	48.50	33.92	44.19	10.06	48.29	74.00	-25.71	Peak	VERTICAL
6015.00	46.54	34.72	43.99	11.35	48.62	74.00	-25.38	Peak	VERTICAL
6168.00	47.87	34.91	43.91	11.97	50.84	74.00	-23.16	Peak	VERTICAL
6695.00	47.17	35.42	43.66	12.07	51.00	74.00	-23.00	Peak	VERTICAL
7868.00	45.53	36.20	43.15	13.70	52.28	74.00	-21.72	Peak	VERTICAL
5776.35 MHz									
4553.00	47.63	33.63	44.28	9.90	46.88	74.00	-27.12	Peak	HORIZONTAL
6015.00	48.12	34.72	43.99	11.35	50.20	74.00	-23.80	Peak	HORIZONTAL
6168.00	46.81	34.91	43.91	11.97	49.78	74.00	-24.22	Peak	HORIZONTAL
6797.00	46.37	35.48	43.61	12.35	50.59	74.00	-23.41	Peak	HORIZONTAL
7392.00	47.43	35.84	43.35	13.05	52.97	74.00	-21.03	Peak	HORIZONTAL
7970.00	45.02	36.28	43.11	14.00	52.19	74.00	-21.81	Peak	HORIZONTAL
4859.00	48.51	33.82	44.23	10.44	48.54	74.00	-25.46	Peak	VERTICAL
6015.00	48.12	34.72	43.99	11.35	50.20	74.00	-23.80	Peak	VERTICAL
6865.00	46.66	35.52	43.58	12.33	50.93	74.00	-23.07	Peak	VERTICAL
7409.00	47.49	35.85	43.34	13.09	53.09	74.00	-20.91	Peak	VERTICAL
8208.00	46.38	36.51	43.22	13.39	53.06	74.00	-20.94	Peak	VERTICAL
8990.00	45.96	36.80	43.62	14.33	53.47	74.00	-20.53	Peak	VERTICAL
5820.35 MHz									
5811.00	47.85	34.55	44.04	11.43	49.79	74.00	-24.21	Peak	HORIZONTAL
7443.00	47.50	35.87	43.33	13.11	53.15	74.00	-20.85	Peak	HORIZONTAL
8361.00	46.55	36.66	43.30	13.48	53.39	74.00	-20.61	Peak	HORIZONTAL
8939.00	46.10	36.80	43.60	14.12	53.42	74.00	-20.58	Peak	HORIZONTAL
9347.00	43.37	37.02	43.80	14.75	53.34	74.00	-20.66	Peak	HORIZONTAL
10282.00	44.85	37.57	44.02	15.33	53.73	74.00	-20.27	Peak	HORIZONTAL
5624.00	47.50	34.40	44.07	11.18	49.01	74.00	-24.99	Peak	VERTICAL
6780.00	47.00	35.47	43.62	12.30	51.15	74.00	-22.85	Peak	VERTICAL
7902.00	45.07	36.22	43.14	13.80	51.95	74.00	-22.05	Peak	VERTICAL
7970.00	45.43	36.28	43.11	14.00	52.60	74.00	-21.40	Peak	VERTICAL
9466.00	45.87	37.09	43.85	14.70	53.81	74.00	-20.19	Peak	VERTICAL
Conclusion: Pass									
Note: $-27 \text{ dBm/MHz Limit} = 95.2 + \text{EIRP}[\text{dBm}] = 95.2 - 27 = 68.2 \text{ dB}\mu\text{V/m}$, all emissions outside of the 5.15-5.35 GHz band shall not exceed an EIRP of -27 dBm/MHz .									

Note:1. Result Level = Read Level + Antenna Factor + Cable loss - PRM Factor.

2. Test setup: RBW: 1 MHz, VBW: 3 MHz, Sweep time: auto.

9. Band Edge Compliance

9.1. Block diagram of test setup

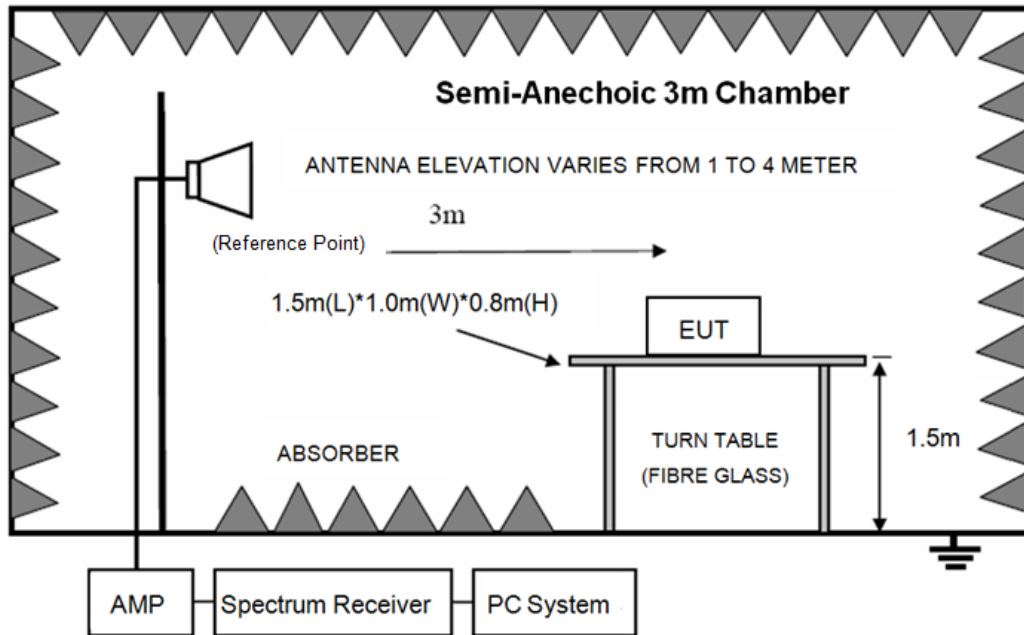

9.2. Limit

For transmitters operating in the 5.15-5.25 GHz and 5.725-5.85 GHz band: all emissions outside of the 5.15-5.35 GHz band shall not exceed an EIRP of -27 dBm/MHz.

$$-27 \text{ dBm/MHz Limit} = 95.2 + \text{EIRP}[\text{dBm}] = 95.2 - 27 = 68.2 \text{ dB}\mu\text{V/m}$$

9.3. Test Procedure

Same with clause 8.3 except change investigated frequency range.

Remark: All restriction band have been tested, and only the worst case is shown in report.

9.4. Test result

PASS. (See below detailed test result)

Note1: As specified in 15.407(b), emissions above 1000 MHz that are outside of the restricted bands are subject to a peak emission limit of -27 dBm/MHz (or -17 dBm/MHz as specified in 15.407(b)(4)).

However, an out-of-band emission that complies with both the average and peak limits of 15.209 is not required to satisfy the -27 dBm/MHz or -17 dBm/MHz peak emission limit

Note2: ANT 1 and ANT 2 mode all have been tested, only ANT 1 mode is the worst case and reported.

TR-4-E-009 Radiated Emission Test Result

Test Site : DDT 3m Chamber 1# **D:\2018 RE1# Report Data\悦晨\FCC ABOVE1G.EM6**
Test Date : 2019-01-03 **Tested By** : Talent
EUT : SOUNDBAR **Model Number** : Bar 2.1 Deep Bass CNTR
Power Supply : AC 230V **Test Mode** : TX mode
Condition : Temp:24.5°C,Humi:55%,Press:100.1kPa **Antenna/Distance** : 2018 HF 907/3m/VERTICAL
Memo : 5736.35

Data: 14

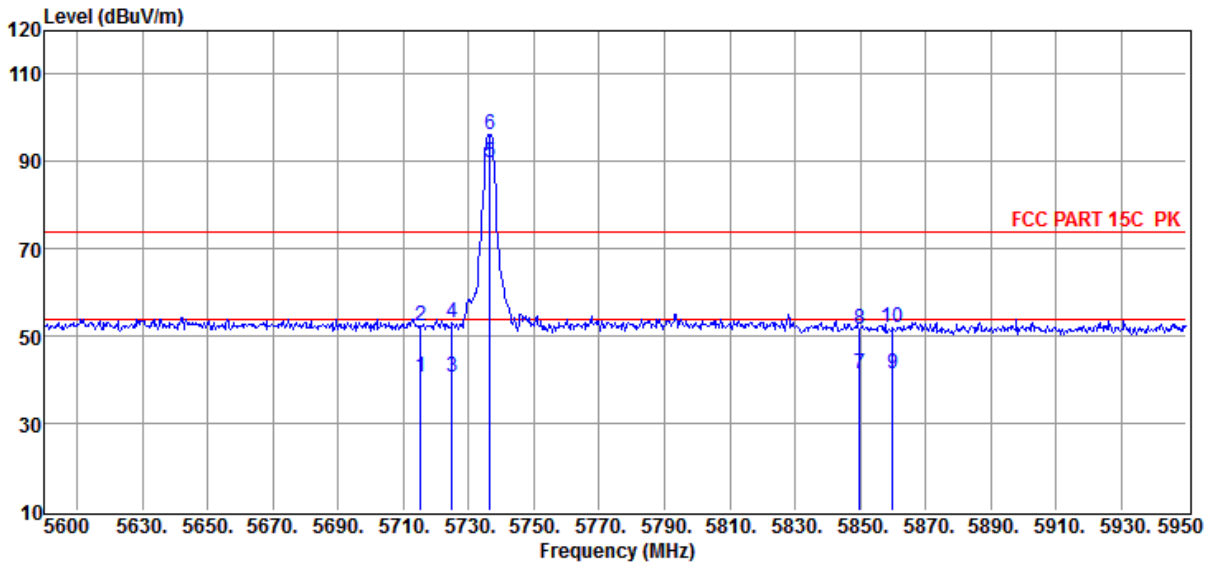

Item (Mark)	Freq. (MHz)	Read Level (dBμV)	Antenna Factor (dB/m)	PRM Factor (dB)	Cable Loss (dB)	Result Level (dBμV/m)	Limit Line (dBμV/m)	Over Limit (dB)	Detector	Polarization
1	5715.15	38.90	34.48	44.05	11.23	40.56	109.4	-68.84	Average	VERTICAL
2	5715.15	50.84	34.48	44.05	11.23	52.50	109.4	-56.90	Peak	VERTICAL
3	5724.95	39.10	34.48	44.05	11.26	40.79	122.2	-81.41	Average	VERTICAL
4	5724.95	51.34	34.48	44.05	11.26	53.03	122.2	-69.17	Peak	VERTICAL
5	5736.35	88.22	34.49	44.05	11.28	89.94	125.2	-35.26	Average	VERTICAL
6	5736.35	94.58	34.49	44.05	11.28	96.30	125.2	-28.90	Peak	VERTICAL
7	5849.90	39.48	34.58	44.03	11.42	41.45	122.2	-80.75	Average	VERTICAL
8	5849.90	49.60	34.58	44.03	11.42	51.57	122.2	-70.63	Peak	VERTICAL
9	5860.05	39.46	34.59	44.03	11.42	41.44	109.4	-67.96	Average	VERTICAL
10	5860.05	49.89	34.59	44.03	11.42	51.87	109.4	-16.36	Peak	VERTICAL

Note: 1. Result Level = Read Level + Antenna Factor + Cable loss - PRM Factor.
 2. If Peak Result complies with AV limit, AV Result is deemed to comply with AV limit.
 3. Test setup: RBW: 1 MHz, VBW: 3 MHz, Sweep time: auto.

TR-4-E-009 Radiated Emission Test Result

Test Site : DDT 3m Chamber 1# **D:\2018 RE1# Report Data\悦晨\FCC ABOVE1G.EM6**
Test Date : 2019-01-03 **Tested By** : Talent
EUT : SOUNDBAR **Model Number** : Bar 2.1 Deep Bass CNTR
Power Supply : AC 230V **Test Mode** : TX mode
Condition : Temp:24.5°C,Humi:55%,Press:100.1kPa **Antenna/Distance** : 2018 HF 907/3m/HORIZONTAL
Memo : 5736.35

Data: 15

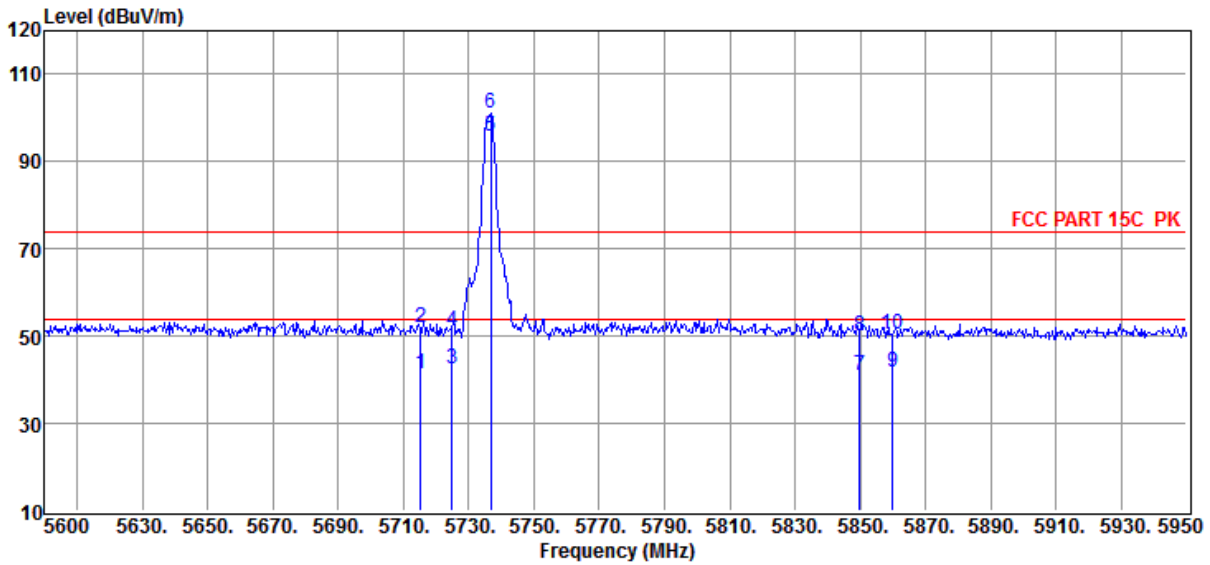

Item (Mark)	Freq. (MHz)	Read Level (dBμV)	Antenna Factor (dB/m)	PRM Factor (dB)	Cable Loss (dB)	Result Level (dBμV/m)	Limit Line (dBμV/m)	Over Limit (dB)	Detector	Polarization
1	5715.15	39.74	34.48	44.05	11.23	41.40	109.4	-68.00	Average	HORIZONTAL
2	5715.15	50.22	34.48	44.05	11.23	51.88	109.4	-57.52	Peak	HORIZONTAL
3	5724.95	40.65	34.48	44.05	11.26	42.34	122.2	-79.86	Average	HORIZONTAL
4	5724.95	49.67	34.48	44.05	11.26	51.36	122.2	-70.84	Peak	HORIZONTAL
5	5736.35	93.92	34.49	44.05	11.28	95.64	125.2	-29.56	Average	HORIZONTAL
6	5736.35	99.23	34.49	44.05	11.28	100.95	125.2	-24.25	Peak	HORIZONTAL
7	5849.90	39.02	34.58	44.03	11.42	40.99	122.2	-81.21	Average	HORIZONTAL
8	5849.90	48.18	34.58	44.03	11.42	50.15	122.2	-72.05	Peak	HORIZONTAL
9	5860.05	39.79	34.59	44.03	11.42	41.77	109.4	-67.63	Average	HORIZONTAL
10	5860.05	48.43	34.59	44.03	11.42	50.41	109.4	-16.36	Peak	HORIZONTAL

Note: 1. Result Level = Read Level + Antenna Factor + Cable loss - PRM Factor.
 2. If Peak Result complies with AV limit, AV Result is deemed to comply with AV limit.
 3. Test setup: RBW: 1 MHz, VBW: 3 MHz, Sweep time: auto.

TR-4-E-009 Radiated Emission Test Result

Test Site : DDT 3m Chamber 1# **D:\2018 RE1# Report Data\悦晨\FCC ABOVE1G.EM6**
Test Date : 2019-01-03 **Tested By** : Talent
EUT : SOUNDBAR **Model Number** : Bar 2.1 Deep Bass CNTR
Power Supply : AC 230V **Test Mode** : TX mode
Condition : Temp:24.5°C,Humi:55%,Press:100.1kPa **Antenna/Distance** : 2018 HF 907/3m/VERTICAL
Memo : 5776.35

Data: 18

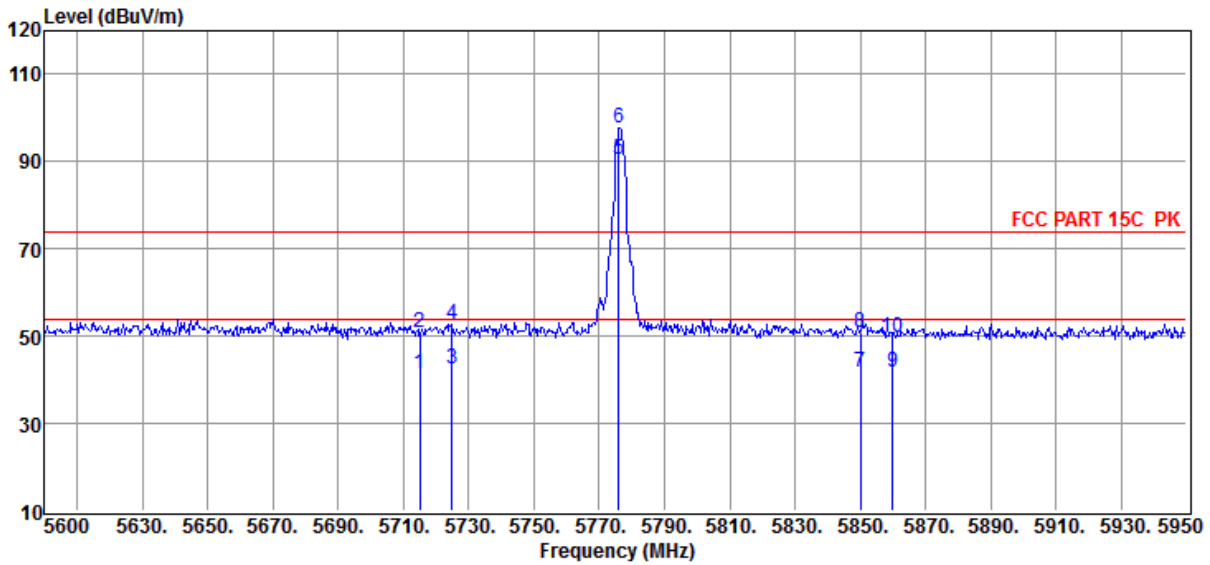

Item (Mark)	Freq. (MHz)	Read Level (dBUV)	Antenna Factor (dB/m)	PRM Factor (dB)	Cable Loss (dB)	Result Level (dBUV/m)	Limit Line (dBUV/m)	Over Limit (dB)	Detector	Polarization
1	5715.00	39.65	34.48	44.05	11.23	41.31	109.4	-68.09	Average	VERTICAL
2	5715.00	49.24	34.48	44.05	11.23	50.90	109.4	-58.50	Peak	VERTICAL
3	5725.00	40.66	34.48	44.05	11.26	42.35	122.2	-79.85	Average	VERTICAL
4	5725.00	51.09	34.48	44.05	11.26	52.78	122.2	-69.42	Peak	VERTICAL
5	5776.35	88.74	34.53	44.04	11.37	90.60	125.2	-34.60	Average	VERTICAL
6	5776.35	95.72	34.53	44.04	11.37	97.58	125.2	-27.62	Peak	VERTICAL
7	5850.00	39.88	34.58	44.03	11.42	41.85	122.2	-80.35	Average	VERTICAL
8	5850.00	48.88	34.58	44.03	11.42	50.85	122.2	-71.35	Peak	VERTICAL
9	5860.00	39.85	34.59	44.03	11.42	41.83	109.4	-67.57	Average	VERTICAL
10	5860.00	47.79	34.59	44.03	11.42	49.77	109.4	-16.36	Peak	VERTICAL

Note: 1. Result Level = Read Level + Antenna Factor + Cable loss - PRM Factor.
 2. If Peak Result complies with AV limit, AV Result is deemed to comply with AV limit.
 3. Test setup: RBW: 1 MHz, VBW: 3 MHz, Sweep time: auto.

TR-4-E-009 Radiated Emission Test Result

Test Site : DDT 3m Chamber 1# **D:\2018 RE1# Report Data\悦晨\FCC ABOVE1G.EM6**
Test Date : 2019-01-03 **Tested By** : Talent
EUT : SOUNDBAR **Model Number** : Bar 2.1 Deep Bass CNTR
Power Supply : AC 230V **Test Mode** : TX mode
Condition : Temp:24.5°C,Humi:55%,Press:100.1kPa **Antenna/Distance** : 2018 HF 907/3m/HORIZONTAL
Memo : 5776.35

Data: 19

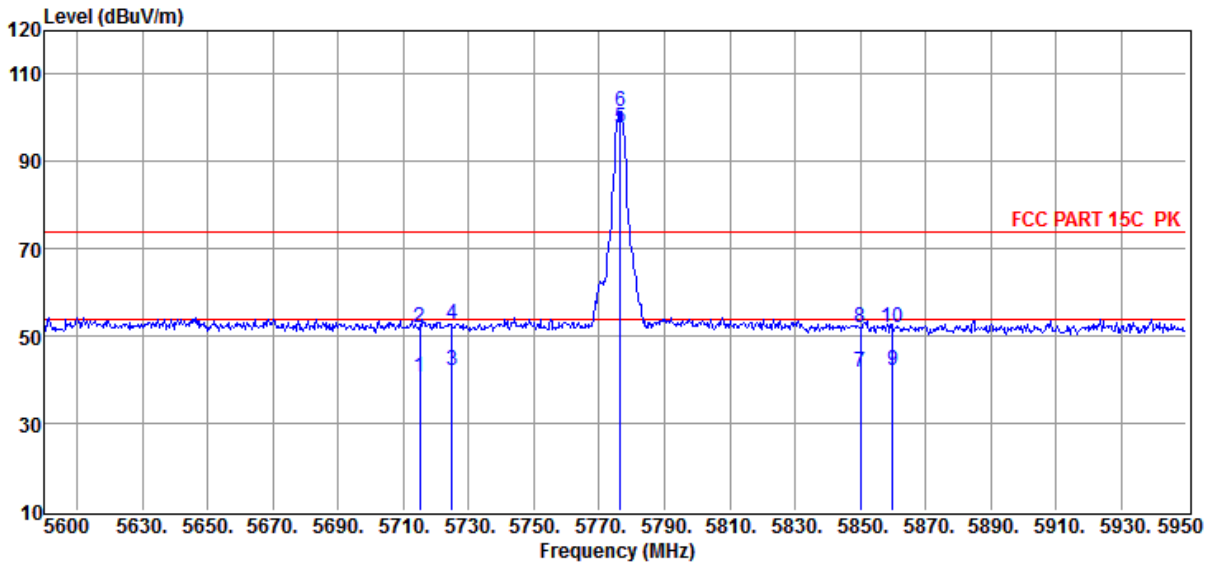

Item (Mark)	Freq. (MHz)	Read Level (dBUV)	Antenna Factor (dB/m)	PRM Factor (dB)	Cable Loss (dB)	Result Level (dBUV/m)	Limit Line (dBUV/m)	Over Limit (dB)	Detector	Polarization
1	5715.00	39.01	34.48	44.05	11.23	40.67	109.4	-68.73	Average	HORIZONTAL
2	5715.00	50.13	34.48	44.05	11.23	51.79	109.4	-57.61	Peak	HORIZONTAL
3	5725.00	40.33	34.48	44.05	11.26	42.02	122.2	-80.18	Average	HORIZONTAL
4	5725.00	51.09	34.48	44.05	11.26	52.78	122.2	-69.42	Peak	HORIZONTAL
5	5776.35	95.83	34.53	44.04	11.38	97.70	125.2	-27.50	Average	HORIZONTAL
6	5776.35	99.68	34.53	44.04	11.38	101.55	125.2	-23.65	Peak	HORIZONTAL
7	5850.00	39.88	34.58	44.03	11.42	41.85	122.2	-80.35	Average	HORIZONTAL
8	5850.00	49.90	34.58	44.03	11.42	51.87	122.2	-70.33	Peak	HORIZONTAL
9	5860.00	40.33	34.59	44.03	11.42	42.31	109.4	-67.09	Average	HORIZONTAL
10	5860.00	49.91	34.59	44.03	11.42	51.89	109.4	-16.36	Peak	HORIZONTAL

Note: 1. Result Level = Read Level + Antenna Factor + Cable loss - PRM Factor.
 2. If Peak Result complies with AV limit, AV Result is deemed to comply with AV limit.
 3. Test setup: RBW: 1 MHz, VBW: 3 MHz, Sweep time: auto.

TR-4-E-009 Radiated Emission Test Result

Test Site : DDT 3m Chamber 1# **D:\2018 RE1# Report Data\悦晨\FCC ABOVE1G.EM6**
Test Date : 2019-01-03 **Tested By** : Talent
EUT : SOUNDBAR **Model Number** : Bar 2.1 Deep Bass CNTR
Power Supply : AC 230V **Test Mode** : TX mode
Condition : Temp:24.5°C,Humi:55%,Press:100.1kPa **Antenna/Distance** : 2018 HF 907/3m/HORIZONTAL
Memo : 5820.35

Data: 22

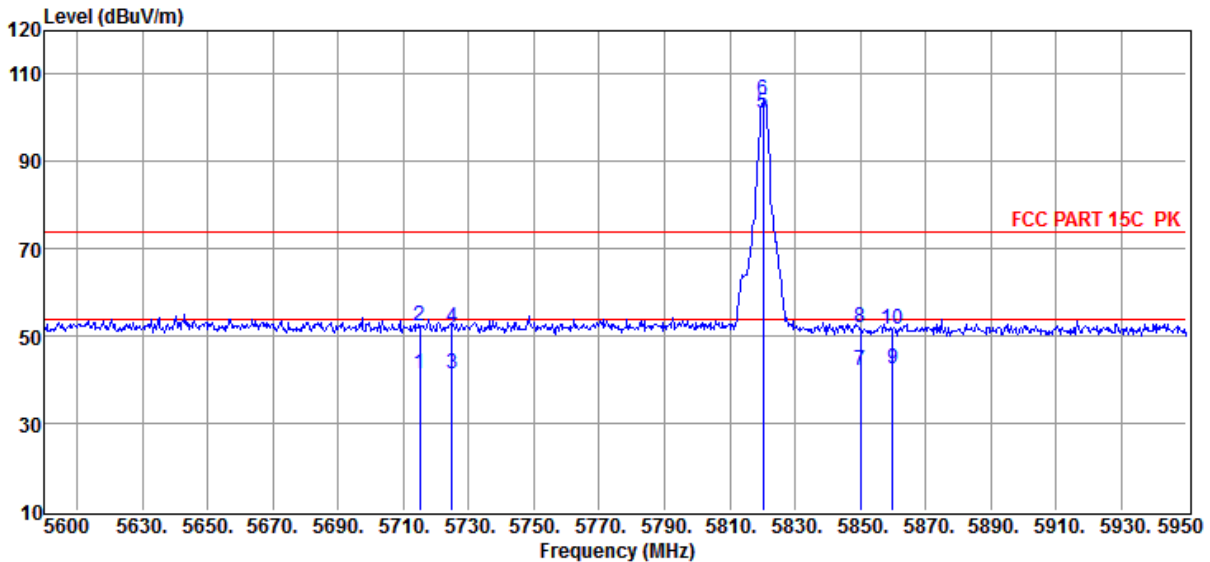

Item (Mark)	Freq. (MHz)	Read Level (dBUV)	Antenna Factor (dB/m)	PRM Factor (dB)	Cable Loss (dB)	Result Level (dBUV/m)	Limit Line (dBUV/m)	Over Limit (dB)	Detector	Polarization
1	5715.00	39.87	34.48	44.05	11.23	41.53	109.4	-67.87	Average	HORIZONTAL
2	5715.00	50.60	34.48	44.05	11.23	52.26	109.4	-57.14	Peak	HORIZONTAL
3	5725.00	39.76	34.48	44.05	11.26	41.45	122.2	-80.75	Average	HORIZONTAL
4	5725.00	50.45	34.48	44.05	11.26	52.14	122.2	-70.06	Peak	HORIZONTAL
5	5820.35	99.25	34.56	44.03	11.43	101.21	125.2	-23.99	Average	HORIZONTAL
6	5820.35	102.34	34.56	44.03	11.43	104.30	125.2	-20.90	Peak	HORIZONTAL
7	5850.00	40.22	34.58	44.03	11.42	42.19	122.2	-80.01	Average	HORIZONTAL
8	5850.00	49.88	34.58	44.03	11.42	51.85	122.2	-70.35	Peak	HORIZONTAL
9	5860.00	40.55	34.59	44.03	11.42	42.53	109.4	-66.87	Average	HORIZONTAL
10	5860.00	49.75	34.59	44.03	11.42	51.73	109.4	-16.36	Peak	HORIZONTAL

- Note: 1. Result Level = Read Level + Antenna Factor + Cable loss - PRM Factor.
 2. If Peak Result complies with AV limit, AV Result is deemed to comply with AV limit.
 3. Test setup: RBW: 1 MHz, VBW: 3 MHz, Sweep time: auto.

TR-4-E-009 Radiated Emission Test Result

Test Site : DDT 3m Chamber 1# **D:\2018 RE1# Report Data\悦晨\FCC ABOVE1G.EM6**
Test Date : 2019-01-03 **Tested By** : Talent
EUT : SOUNDBAR **Model Number** : Bar 2.1 Deep Bass CNTR
Power Supply : AC 230V **Test Mode** : TX mode
Condition : Temp:24.5°C,Humi:55%,Press:100.1kPa **Antenna/Distance** : 2018 HF 907/3m/VERTICAL
Memo : 5820.35

Data: 23

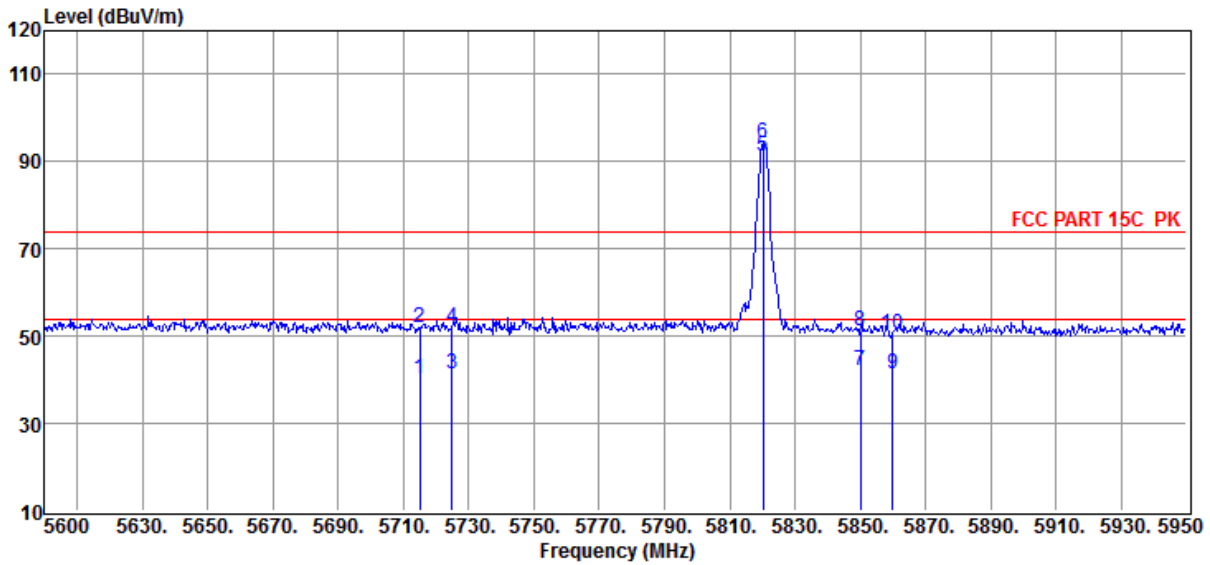

Item (Mark)	Freq. (MHz)	Read Level (dBμV)	Antenna Factor (dB/m)	PRM Factor (dB)	Cable Loss (dB)	Result Level (dBμV/m)	Limit Line (dBμV/m)	Over Limit (dB)	Detector	Polarization
1	5715.00	38.62	34.48	44.05	11.23	40.28	109.4	-69.12	Average	VERTICAL
2	5715.00	50.33	34.48	44.05	11.23	51.99	109.4	-57.41	Peak	VERTICAL
3	5725.00	39.54	34.48	44.05	11.26	41.23	122.2	-80.97	Average	VERTICAL
4	5725.00	50.19	34.48	44.05	11.26	51.88	122.2	-70.32	Peak	VERTICAL
5	5820.35	89.17	34.56	44.03	11.43	91.13	125.2	-34.07	Average	VERTICAL
6	5820.35	92.20	34.56	44.03	11.43	94.16	125.2	-31.04	Peak	VERTICAL
7	5850.00	40.13	34.58	44.03	11.42	42.10	122.2	-80.10	Average	VERTICAL
8	5850.00	49.12	34.58	44.03	11.42	51.09	122.2	-71.11	Peak	VERTICAL
9	5860.00	39.54	34.59	44.03	11.42	41.52	109.4	-67.88	Average	VERTICAL
10	5860.00	48.63	34.59	44.03	11.42	50.61	109.4	-16.36	Peak	VERTICAL

Note: 1. Result Level = Read Level + Antenna Factor + Cable loss - PRM Factor.
 2. If Peak Result complies with AV limit, AV Result is deemed to comply with AV limit.
 3. Test setup: RBW: 1 MHz, VBW: 3 MHz, Sweep time: auto.

10. Power Line Conducted Emission

10.1. Block diagram of test setup

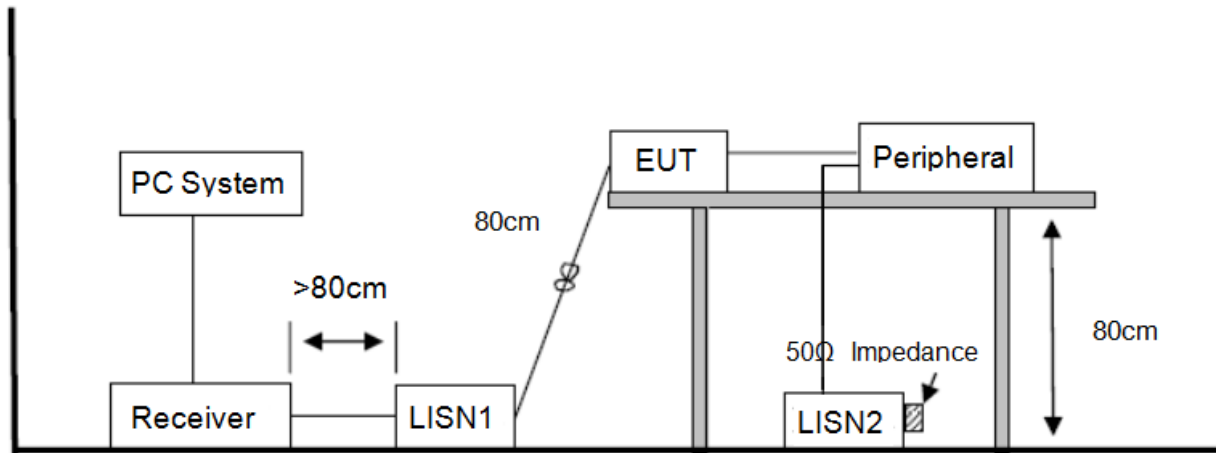

10.2. Power Line Conducted Emission Limits (Class B)

Frequency	Quasi-Peak Level dB(μ V)	Average Level dB(μ V)
150kHz ~ 500kHz	66 ~ 56*	56 ~ 46*
500kHz ~ 5MHz	56	46
5MHz ~ 30MHz	60	50

Note 1: * Decreasing linearly with logarithm of frequency.

Note 2: The lower limit shall apply at the transition frequencies.

10.3. Test Procedure

The EUT and Support equipment, if needed, were put placed on a non-metallic table, 80cm above the ground plane.

Configuration EUT to simulate typical usage as described in clause 2.3 and test equipment as described in clause 10.2 of this report.

All I/O cables were positioned to simulate typical actual usage as per ANSI C63.4.

All support equipment power received from a second LISN.

Emissions were measured on each current carrying line of the EUT using an EMI Test Receiver connected to the LISN powering the EUT.

The Receiver scanned from 150 kHz to 30MHz for emissions in each of the test modes.

During the above scans, the emissions were maximized by cable manipulation.

The test mode(s) described in clause 2.3 were scanned during the preliminary test.

After the preliminary scan, we found the test mode producing the highest emission level.

The EUT configuration and worse cable configuration of the above highest emission levels were recorded for reference of the final test.

EUT and support equipment were set up on the test bench as per the configuration with highest emission level in the preliminary test.

A scan was taken on both power lines, Neutral and Line, recording at least the six highest emissions.

Emission frequency and amplitude were recorded into a computer in which correction factors were used to calculate the emission level and compare reading to the applicable limit.

The test data of the worst-case condition(s) was recorded.

The bandwidth of test receiver is set at 9 kHz.

10.4. Test Result

PASS. (See below detailed test result)

Note1: All emissions not reported below are too low against the prescribed limits.

Note2: “-----” means peak detection; “-----” means average detection

Note3: Pre-test AC conducted emission at both voltage AC 120V/60Hz and AC 240V/50Hz, recorded worse case.

TR-4-E-010 Conducted Emission Test Result

Test Site : DDT 1# Shield Room D:\2018 CE report data\Q18112313-1E\CE.EM6
Test Date : 2019-01-31 **Tested By** : Aaron
EUT : SOUNDBAR **Model Number** : Bar 2.1 Deep Bass CNTR
Power Supply : AC 230V **Test Mode** : TX mode
Condition : Temp:24.5°C,Humi:55%,Press:100.1KPa **LISN** : 2018 ENV216/NEUTRAL
Memo :

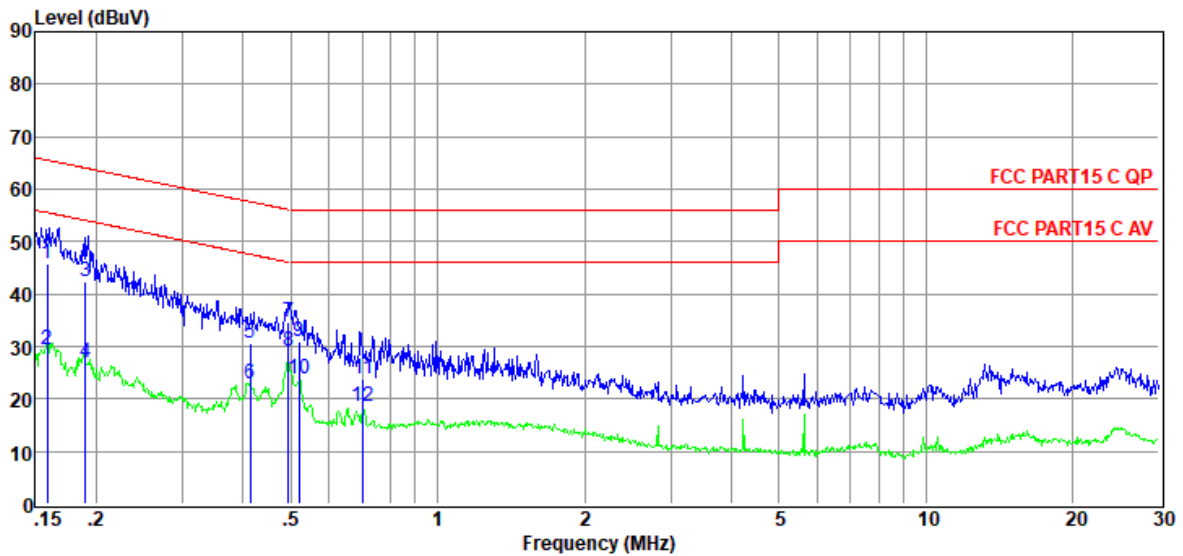

Item (Mark)	Freq. (MHz)	Read Level (dBμV)	LISN Factor (dB)	Cable Loss (dB)	Pulse Limiter Factor (dB)	Result Level (dBμV)	Limit Line (dBμV)	Over Limit (dB)	Detector	Phase
1	0.16	26.35	9.64	0.02	9.86	45.87	65.52	-19.65	QP	NEUTRAL
2	0.16	9.81	9.64	0.02	9.86	29.33	55.52	-26.19	Average	NEUTRAL
3	0.19	22.97	9.64	0.02	9.86	42.49	64.02	-21.53	QP	NEUTRAL
4	0.19	7.38	9.64	0.02	9.86	26.90	54.02	-27.12	Average	NEUTRAL
5	0.41	11.13	9.64	0.02	9.86	30.65	57.59	-26.94	QP	NEUTRAL
6	0.41	3.39	9.64	0.02	9.86	22.91	47.59	-24.68	Average	NEUTRAL
7	0.49	15.10	9.64	0.02	9.86	34.62	56.10	-21.48	QP	NEUTRAL
8	0.49	9.47	9.64	0.02	9.86	28.99	46.10	-17.11	Average	NEUTRAL
9	0.52	11.38	9.64	0.02	9.86	30.90	56.00	-25.10	QP	NEUTRAL
10	0.52	4.15	9.64	0.02	9.86	23.67	46.00	-22.33	Average	NEUTRAL
11	0.70	4.27	9.64	0.04	9.86	23.81	56.00	-32.19	QP	NEUTRAL
12	0.70	-0.92	9.64	0.04	9.86	18.62	46.00	-27.38	Average	NEUTRAL

- Note: 1. Result Level = Read Level +LISN Factor + Pulse Limiter Factor + Cable loss.
 2. If QP Result complies with AV limit, AV Result is deemed to comply with AV limit.
 3. Test setup: RBW: 200 Hz (9 kHz—150 kHz), 9 kHz (150 kHz—30 MHz).
 4. Step size: 80Hz (0.009MHz-0.15MHz), 4 kHz (0.15MHz-30MHz), Scan time: auto.

TR-4-E-010 Conducted Emission Test Result

: DDT 1# Shield Room
 D:\2018 CE report data\Q18112313-1E\CE.EM6
Test Date : 2019-01-31 **Tested By** : Aaron
EUT : SOUNDBAR **Model Number** : Bar 2.1 Deep Bass CNTR
Power Supply : AC 230V **Test Mode** : TX mode
Condition : Temp:24.5°C,Humi:55%,Press:100.1KPa **LISN** : 2018 ENV216/LINE
Memo :

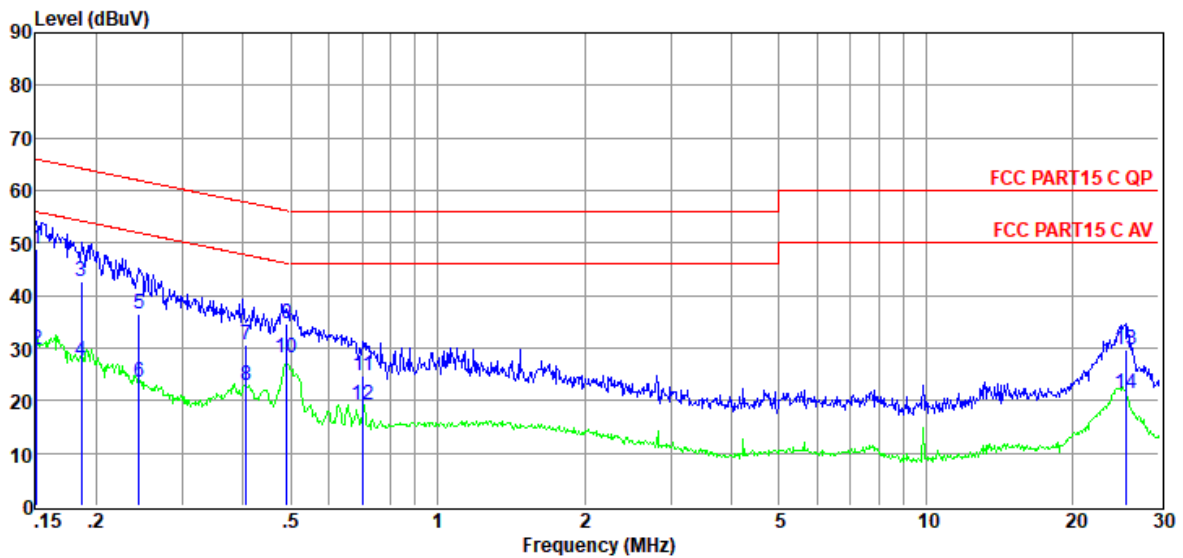

Item	Freq.	Read Level	LISN Factor	Cable Loss	Pulse Limiter Factor	Result Level	Limit Line	Over Limit	Detector	Phase
(Mark)	(MHz)	(dBμV)	(dB)	(dB)	(dB)	(dBμV)	(dBμV)	(dB)		
1	0.15	29.25	9.63	0.02	9.86	48.76	65.96	-17.20	QP	LINE
2	0.15	10.33	9.63	0.02	9.86	29.84	55.96	-26.12	Average	LINE
3	0.19	23.06	9.63	0.02	9.86	42.57	64.20	-21.63	QP	LINE
4	0.19	8.12	9.63	0.02	9.86	27.63	54.20	-26.57	Average	LINE
5	0.24	16.93	9.63	0.02	9.86	36.44	61.95	-25.51	QP	LINE
6	0.24	4.03	9.63	0.02	9.86	23.54	51.95	-28.41	Average	LINE
7	0.41	10.95	9.64	0.02	9.86	30.47	57.73	-27.26	QP	LINE
8	0.41	3.21	9.64	0.02	9.86	22.73	47.73	-25.00	Average	LINE
9	0.49	15.11	9.64	0.02	9.86	34.63	56.14	-21.51	QP	LINE
10	0.49	8.59	9.64	0.02	9.86	28.11	46.14	-18.03	Average	LINE
11	0.70	5.25	9.64	0.04	9.86	24.79	56.00	-31.21	QP	LINE
12	0.70	-0.37	9.64	0.04	9.86	19.17	46.00	-26.83	Average	LINE
13	25.59	9.54	9.98	0.14	9.99	29.65	60.00	-30.35	QP	LINE
14	25.59	1.30	9.98	0.14	9.99	21.41	50.00	-28.59	Average	LINE

Note: 1. Result Level = Read Level + LISN Factor + Pulse Limiter Factor + Cable loss.
 2. If QP Result complies with AV limit, AV Result is deemed to comply with AV limit.
 3. Test setup: RBW: 200 Hz (9 kHz—150 kHz), 9 kHz (150 kHz—30 MHz).
 4. Step size: 80Hz (0.009MHz-0.15MHz), 4 kHz (0.15MHz-30MHz), Scan time: auto

11. Antenna Requirements

11.1. Limit

For intentional device, according to FCC 47 CFR Section 15.203, an intentional radiator shall be designed to ensure that no antenna other than that furnished by the responsible party shall be used with the device. And according to FCC 47 CFR Section 15.247 (b), if transmitting antennas of directional gain greater than 6dBi are used, the power shall be reduced by the amount in dB that the directional gain of the antenna exceeds 6dBi.

11.2. Result

The antennas used for this product are integrated antenna and other than that furnished by the responsible party shall be used with the device, the maximum peak gain of the transmit antenna is 3.50 dBi

END OF REPORT