

Emission Test Report
Standard: FCC Part 15 Subpart E / IC RSS-210
Class II Permissive change

Document Number : FCC 19-0256-0

Model Number: PH12127-E

measured with **IBM ThinkPad T40 Series, 15 inch model**

FCC ID: ANO20030400LEG
IC: 349E-PH12127E

March 5, 2004

Prepared:
EMC R&D Staff Engineer
Takeshi Asano

Signature: 
IBM Japan, Ltd.
EMC Engineering
LAB-S59
1623-14, Shimotsuruma,
Yamato-shi Kanagawa-ken 242, Japan
Phone: +81-46-215-4779
Fax: +81-46-273-7420
E-Mail: asano@jp.ibm.com

Reviewed and Checked:
EMC R&D Staff Engineer
Shigeru Motoki

Signature: 
IBM Japan, Ltd.
EMC Engineering
LAB-S59
1623-14, Shimotsuruma,
Yamato-shi Kanagawa-ken 242, Japan
Phone: +81-46-215-2239
Fax: +81-46-273-7420
E-Mail: motokis@jp.ibm.com

Approved:
Manager, EMC Engineering
/ NVLAP signatory

Akihisa Sakurai
Signature: 
IBM Japan, Ltd.
EMC Engineering
LAB-S59
1623-14, Shimotsuruma,
Yamato-shi Kanagawa-ken 242, Japan
Phone: +81-46-215-2613
Fax: +81-46-273-7420
E-Mail: akihisa@jp.ibm.com

MEASUREMENT / TECHNICAL REPORT – Part 15 Subpart E (Intentional Radiator)

**Model: PH12127-E (802.11a/b/g Wireless LAN Adapter)
with
IBM ThinkPad T40 Series, 15 inch model
(Machine Type: 2373, 2374, 2375, 2376, 2378, 2379)**

FCC ID : ANO20030400LEG

March 5, 2004

This report concerns: (check one)	
Original Grant	_____
Class I change	_____
Class II change	_____ <input checked="" type="checkbox"/>
Equipment type: <u>Wireless LAN device</u>	
This report shall not be reproduced except in full, without the written permission of this test lab.	
The measurement results contained in this report relate only to the item which was tested.	
Measurement procedure used is ANSI C63.4-2000 unless otherwise specified.	
Other test procedure: _____	
The FCC has issued provisional acceptance of this test laboratory for Declaration of Conformity testing per letter dated 1997.	
<i>APPLICANT ANTI-DRUG ABUSE CERTIFICATION:</i>	
By checking yes, the applicant certifies that, in the case of an individual applicant, he or she is not subject to a denial of federal benefits, that includes FCC benefits, pursuant to Section 5301 of the Anti-Drug Abuse of 1988, 21 U.S.C. 853(a), or, in the case of a non-individual applicant (e.g. corporation, partnership or other unincorporated association), no party to the application is subject to a denial of federal benefits, that includes FCC benefits, pursuant to that section. For the definition of a “party” for these purposes, see 47 CFR 1.2002(b).	
<input checked="" type="radio"/> Yes or No	
“Report shall not be reproduced except in full, without the written approval of the laboratory” “the report must not be used by the client to claim product endorsement by NVLAP or any agency of the US government”	
Prepared by: Takeshi Asano	
IBM Japan Corporation, Yamato EMC Engineering LAB-S59, 1623-14, Shimotsuruma, Yamato-shi Kanagawa-ken 242-8502, Japan Tel: +81-46-215-4779 Fax: +81-46-273-7420	

- Index -

A. GENERAL INFORMATION 5

A.1 Test Methodology 5

A.2 Test Facility / NVLAP Accreditation 5

A.3 EUT details 5

B. SUMMARY OF TEST RESULTS 6

C. TEST INSTRUMENTS 7

D. OPERATION MODE OF EUT 9

E. JUSTIFICATION 9

F. MEASUREMENT UNCERTAINTY 10

G. TEMPERATURE AND HUMIDITY 10

H. RELATED SUBMITTAL(S)/GRANT(S)/NOTES 10

1. BANDWIDTH AT 26 DB BELOW / BANDEDGE 11

1.1 Test Procedure 11

1.2 Measurement Results 11

1.3 Trace Data 12

2. PEAK CONDUCTED TRANSMIT OUTPUT POWER 15

2.1 Test Procedure 15

2.2 Measurement Results 17

2.3 Trace Data 18

3. PEAK POWER SPECTRAL DENSITY 21

3.1 Test Procedure 21

3.2 Measurement Results 21

3.3 Trace Data 22

4. PEAK EXCURSION RATIO 28

4.1 Test Procedure 28

4.2 Measurement Results 28

4.3 Trace Data 29

5. AC WIRELINE CONDUCTED EMISSIONS (150KHZ – 30MHZ) 32

5.1 Test Procedure 32

5.2 Test Instruments and Measurement Setup 32

5.3 Powerline Voltage Calculation 33

5.4 Measurement Results 34

6. RESTRICTED BANDS RADIATIONS (30MHZ – 1GHZ) 36

6.1 Test Procedure 36

6.2 Test Instruments and Measurement Setup 36

6.3 Field Strength Calculation 38

6.4 Measurement Results 39

7. RESTRICTED BANDS RADIATIONS (1GHZ – 40GHZ)..... 40

7.1 Test Procedure.....40

7.2 Test Instruments and Measurement Setup40

7.3 Field Strength Calculation.....42

7.4 Limits42

7.5 Measurement Results.....43

7.6 Trace Data.....45

A. General Information

APPLICANT : IBM Japan, Ltd.
TEST SITE : IBM Japan, Ltd., Yamato Semi-anechoic chamber #1
TEST SITE ADDRESS : 1623 – 14 Shimotsuruma, Yamato-shi, Kanagawa 242-8502 Japan
 Tel: +81-46-215-4779, Fax: +81-46-273-7420
REGULATION : FCC Part 15 Subpart E
 Industry Canada RSS-210 (Issue No.5)
MODEL NAME : PH12127-E
 (Advertising Name) (IBM 11a/b/g Wireless LAN Mini PCI Adapter)
FCC ID : ANO20030400LEG
IC Certification Number : 349E-PH12127E
SERIAL NUMBER : 11S91P7300Z1Z8MK3A30PA
PHYSICAL CONDITION : Preproduction
KIND OF EQUIPMENT : Personal computer with a IEEE802.11a, 11b & 11g Wireless LAN
 Mini-PCI Combo Card ([Composite application](#))
TESTED DATE : February 17, 23, 24, 25, 26 and 27, 2004

A.1 Test Methodology

Both conducted and radiated testing were performed according to the procedures in ANSI C63.4-2000. Radiated testing was performed at an antenna to EUT distance of 3 meters.

A.2 Test Facility / NVLAP Accreditation

The semi-anechoic chamber #1 used to correct the data are located in Yamato Laboratory, IBM Japan.

- This facility has been fully described in a report dated September 1998, submitted to the FCC office, and accepted in a letter, dated Nov. 2, 1998(31040/SIT).
- IBM Yamato EMC Engineering is recognized under the National Voluntary Laboratory Accreditation Program for satisfactory compliance with Criteria established in Title 15, Part 285 Code of Federal Regulations. (**NVLAP Lab code: 200198-0**)
- These facilities are accepted by **Industry Canada** as number **IC 4221** for chamber #1 (expiry date: January 25, 2005), and as number **IC 4221-1** for chamber #2 (expiry date: February 16, 2007).

A.3 EUT details

Table-A EUT details

Model and S/N	FCC ID IC Certification Number	Description
PH12127-E (s/n:11S91P7300Z1Z8MK3A30PA)	FCC ID: ANO20030400LEG IC: 349E-PH12127E	Applying equipment IEEE802.11a/b/g Wireless LAN Mini-PCI Combo Card without antenna
ThinkPad T40 Series M/T : 2373-PUU(15inch) (s/n ZZ-22134)	N/A	IBM Notebook PC with built_in antenna CPU: Intel® Pentium® M Processor 735
P/N 02K6746	N/A	Universal AC adapter 72W, Unshielded power cord

B. Summary of Test Results

Table-B presents the list of the measurement items for U-NII devices under FCC Part 15 Subpart E, and for LELAN devices under Industry Canada RSS-210.

The section numbers of upper portion are showing FCC codes, and the lower ones are for IC RSS-210.

Table-B List of the measurements

Section(s)	Test Items		Condition	Result
	Transmit mode (TX):			
15.407(a)(1), (2) 6.2.2 (q1)(i)(ii)	Bandwidth at 26 dB below	26dB BW was also taken for IC instead of 99% BW, according to RSS-210 6.2.2q(iv)(b).	Conducted	Pass
	Peak conducted transmit output power or EIRP for IC	5150-5250MHz: FCC: 50mW or (4+10logB)dBm IC : 200mW* or (10+10logB)dBm* *: EIRP 5250-5350MHz: FCC: 250mW or (11+10logB)dBm IC : 250mW or (11+10logB)dBm IC : 1W* or (17+10logB)dBm* *: EIRP B: 26dB BW in MHz		Pass
	Peak Power Spectral Density	5150-5250MHz: FCC: 4 dBm in any 1MHz IC : 10 dBm in any 1MHz (EIRP) 5250-5350MHz: FCC: 11 dBm in any 1MHz IC : 11 dBm in any 1MHz		Pass
	N/A 6.2.2 (q1)(iv)(b)	IC: 3 + 10logB dBm/MHz		Pass
15.407(a)(6) N/A	Peak Excursion	The ratio of the peak excursion of the modulation envelope to the peak transmit shall not exceed 13 dB across any 1 MHz .	Pass	
15.207 / 407(b)(5) 6.2.2 (q1)(v) / 6.6	AC Wireline Conducted Emissions 150kHz- 30MHz	Class B: Freq.(MHz) QP(dBμV) Ave.(dBμV) 0.15 - 0.5 66 - 56 56 - 46 0.5 - 5 56 46 5 - 30 60 50	Pass	
15.205 & 209 / 407(b)(1)(2)(5)(6) 6.2.1 / 6.2.2(q1)(i)(ii)(v) / 6.3	General Field Strength Limits (Restricted Bands and Radiated Emission Limits)	Shall not exceed the limits specified in FCC 15.209 or RSS-210 Table3. Ave. 54dBμV/m, peak 74dBμV/m and	Radiated (30MHz -1GHz)	Pass
		FCC 15.407(b)(1)(2) or RSS-210 6.2.2(q1)(i)(ii) : EIRP -27dBm/MHz	Radiated (1G -40GHz)	Pass

		Receive mode (RX):			
15.207 / 407(b)(5) 6.2.2(q1)(v) / 7.4	AC Wireline Conducted Emissions 150kHz - 30MHz	Class B: Freq.(MHz) QP(dBμV) Ave.(dBμV) 0.15 - 0.5 66 - 56 56 - 46 0.5 - 5 56 46 5 - 30 60 50	Conducted	Pass	

15.205 & 209 / 407(b)(1)(2)(5)(6) 6.2.1 / 6.2.2(q1)(i)(ii)(v) / 7.3	General Field Strength Limits (Radiated Emission Limits)	Shall not exceed the limits specified in FCC 15.209 or RSS-210 Table3. Ave. 54dB μ V/m, peak 74dB μ V/m and	Radiated (30MHz -1GHz)	Pass
		FCC 15.407(b)(1)(2) or RSS-210 6.2.2(q1)(i)(ii) : EIRP -27dBm/MHz	Radiated (1G - 40GHz)	Pass

	Other general requirements		Result
15.407(a)(1)(2)	Antenna gain	Peak : 2.00 dBi in 5180-5320MHz band	N/A
5.2	Supply Voltage	Main power source: Universal AC adapter 72W Mini-PCI PC bus to applying card : DC 3.3V \pm 0.3V	N/A
6.2.2(q1)(iv)(a)	Digital modulation	Applying equipment employs IEEE802.11a, 11g(OFDM) or 11b(CCK) digital modulation technology.	complies
15.407(c) 6.2.2(q1)(iv)(d)	Automatic link disconnection in no transaction state	Refer to “Circuitry Description” document.	complies
15.407(d) 6.2.2(q1)(i)	Integral antenna in the 5150M -5250MHz band	The device employs an unique electronic handshake connector. Refer to “Confidential_BIOS_Lock” exhibit.	complies
15.407(e) 6.2.2(q1)(i) (q1)(iv)(g)	Indoor use in the 5150M -5250MHz band, and interference from radars.	Refer to the manual (Regulatory Notice).	complies
15.407(f) 6.2.2(q1)(iv)(g)	RF Exposure Requirement	Refer to “RF Exposure Evaluation” or “Exposure of Humans to Radio Frequency Fields“ documents.	complies
15.407(g) 6.2.2(q1)(iv)(e)	Frequency stability	Refer to “Circuitry Description” document.	complies

C. Test Instruments

Table-C List of Measuring Instruments

Description	Model	Serial Number	Calibration Date	Calibration Interval
Computer	IBM 6868-30J	97-901X3	N/A	N/A
Computer	IBM 6589-13J	97-15613	N/A	N/A
Spectrum Analyzer (100Hz-1.5GHz)	HP 85680B	2601A02634	09/09/03	1 year
Spectrum Analyzer (100Hz-1.5GHz)	HP 85680B	3019A05156	08/14/03	1 year
Spectrum Analyzer (100Hz-1.5GHz)	HP 85680B	2841A04254	08/25/03	1 year
Spectrum Analyzer Display	HP 85662A	2542A12308	09/09/03	1 year
Spectrum Analyzer Display	HP 85662A	3026A19366	08/14/03	1 year
Spectrum Analyzer Display	HP 85662A	2816A16831	08/25/03	1 year
Quasi-Peak Adapter	HP 85650A	2043A00062	09/09/03	1 year
Quasi-Peak Adapter	HP 85650A	2811A01433	08/14/03	1 year
Quasi-Peak Adapter	HP 85650A	2811A01156	08/25/03	1 year
Amplifier (100KHz - 1.3GHz)				
- for 30-200MHz	HP 8447F	2805A02919	04/14/03	1 year
- for 200-1000MHz	MITEQ AM-3A	898432	02/20/04	1 year

Amplifier (1 - 18GHz)	HP 8449B	3008A00582	06/11/03	1 year
Amplifier (18 - 40GHz)	Agilent 83051A	3950M00193	01/27/04	1 year
Spectrum Analyzer EMI Test Receiver	R&S ESI26	836119/003	05/01/03	1 year
Spectrum Analyzer	HP 8563E	3416A02248	08/21/03	1 year
Harmonic Mixer	Agilent 11970A	011269-001	07/19/03	1 year
Receiver (9kHz-30MHz)	R&S ESH3	891806/012	10/17/03	1 year
Receiver (20MHz-1.3GHz)	R&S ESVP	892111/030	03/17/03	1 year
Biconical Antenna (30-200MHz)	EMCO 3108	2536	04/23/03	1 year
Log-Periodic Antenna (200-1000MHz)	EMCO 3146	2849	04/23/03	1 year
Horn Antenna (1- 18GHz)	EMCO 3115	9903-5774	07/17/03	1 year
Horn Antenna (3.95- 5.85GHz)	EMCO 3160-5	1099	07/17/03	1 year
Horn Antenna (5.85- 8.20GHz)	EMCO 3160-6	9712-1044	07/17/03	1 year
Horn Antenna (8.2- 12.4GHz)	EMCO 3160-7	1156	07/17/03	1 year
Horn Antenna (12.4- 18GHz)	EMCO 3160-8	1143	07/17/03	1 year
Horn Antenna (18- 26.5GHz)	EMCO 3160-9	0004-1202	07/17/03	1 year
Horn Antenna (26.5- 40GHz)	EMCO 3160-10	1175	07/17/03	1 year
LISN	EMCO 3810/2NM	00022007	05/20/03	1 year
Power Meter	HP 437B	3043U03437	11/19/03	1 year
Power Sensor	HP 8481A	US41030582	11/19/03	1 year
Switch/control unit	HP 3488A	2719A17226	N/A	N/A
		2719A17228	N/A	N/A
Plotter	HP 7550A	2631A33619	N/A	N/A
Coaxial cables (1 – 18GHz):	Length:			
- Horn Ant <=> RF Amp.	6 m	- EM206SCO	03/27/03	1 year
- RF Amp.<=>Spectrum Analyzer(<12GHz)	16m	- GEM0101	03/27/03	1 year
- RF Amp.<=>Spectrum Analyzer(>12GHz)	3 m	- SF102-20166	03/27/03	1 year
Coaxial cables (18 – 40GHz):				
- Horn Ant <=> RF Amp.	3m	- SF102-20167	03/27/03	1 year
- RF Amp.<=>Spectrum Analyzer	1m	- SF102-21105	03/27/03	1 year
N-Coax cables:				
- Bi-coni Ant <=> 10m Cable	9 m	- EM103L01	04/14/03	1 year
- 10m Cable <=> Shield Panel	10 m	- EM103L02	04/14/03	1 year
- Shield Panel <=> RF Amp	7 m	- EM103L03	04/14/03	1 year
- RF Amp <=> Power Splitter	0.5m	- EM103L04	04/14/03	1 year
- Log-peri Ant <=> 10m Cable	9 m	- EM103H01	04/14/03	1 year
- 10m Cable <=> Shield Panel	10 m	- EM103H02	04/14/03	1 year
- Shield Panel <=> RF Amp	7 m	- EM103H03	04/14/03	1 year
- RF Amp <=> Power Splitter	0.5m	- EM103H04	04/14/03	1 year
Coax cables:				
- Lisn-L <=> SW/Con.unit (SW100)	4 m	- EMIC-L	04/14/03	1 year
- Lisn-N <=> SW/Con.unit (SW101)	4 m	- EMIC-N	04/14/03	1 year
- SW/Con.unit <=> RCVR (Input)	1 m	- EMIC-R	04/14/03	1 year
- SW/Con.unit<=> Spe Ana.(Signal In)	1 m	- EMIC-S	04/14/03	1 year
- Power Splitter <=> SW/Con.unit (SW110)	1 m	- EM103L05	04/14/03	1 year
- Power Splitter <=> SW/Con.unit (SW300)	1 m	- EM103L06	04/14/03	1 year
- Power Splitter <=> SW/Con.unit (SW100)	1 m	- EM103H05	04/14/03	1 year
- Power Splitter <=> SW/Con.unit (SW301)	1 m	- EM103H06	04/14/03	1 year
- SW/Con.unit <=> Receiver (Input)	2 m	- EM1RCV	04/14/03	1 year
- SW/Con.unit <=> Spe Ana.(Signal In) for	2 m	- EM1SPL	04/14/03	1 year

30- 200MHz - SW/Con.unit <=> Spe Ana.(Signal In) for 200-1000MHz	2 m	- EM1SPH	04/14/03	1 year
--	-----	----------	----------	--------

Notes.

- The above equipment calibration is traceable to National standards.
- HP: Hewlett Packard, R&S: Rohde & Schwarz

D. Operation mode of EUT

1. All tests were performed using the “Atheros Radio Test” program. This tool supports to emit the continuous transmission mode for the testing purpose.
2. Three kinds of frequencies were chosen for the measurement. i.e. 5180MHz (lowest), 5260MHz(middle), and 5320MHz (highest).

Table-D Transmission mode of EUT (The measurement plots are shown in shading.)

Operation Frequency [GHz]	Rated output power (conducted) [dBm]							
	6M bps	9M bps	12M bps	18M bps	24M bps	36M bps	48M bps	54M bps
5.180 (Ch. 36)	+14	+14	+14	+14	+14	+14	+14	+13
5.200 (Ch. 40)	+14	+14	+14	+14	+14	+14	+14	+13
5.220 (Ch. 44)	+14	+14	+14	+14	+14	+14	+14	+13
5.240 (Ch. 48)	+14	+14	+14	+14	+14	+14	+14	+13
5.260 (Ch. 52)	+17	+17	+17	+17	+17	+15	+14	+13
5.280 (Ch. 56)	+17	+17	+17	+17	+17	+15	+14	+13
5.300 (Ch. 60)	+17	+17	+17	+17	+17	+15	+14	+13
5.320 (Ch. 64)	+14	+14	+14	+14	+14	+14	+14	+13

3. 24Mbps transmission mode was selected for full testing as the worst case sampling. See “Chapter 2. Peak Conducted Transmit Output Power” as to the determination of measurement plots.
4. As for the RF receiving test, the middle channel with the worst case(i.e. 5260MHz, 24Mbps mode) was selected representatively.

E. Justification

The EUT was investigated for both the main (left) and the auxiliary (right) antennas for each Tx mode. The worse case data taken in this report represents the measurement result of the left antenna that has comparatively higher gain in 5.2GHz band as shown below.

Table-D Peak Antenna Gains of EUT

	Left Antenna gain	Right Antenna gain
5.2GHz band	2.00 dBi (peak)	0.82 dBi (peak)

And the columns marked with shading in the Table-C are the worst cases of each Tx mode for all measurement items. This test report represents the measurement results performed with those Tx modes.

F. Measurement Uncertainty

Uncertainties of the both, the Yamato EMI radiated test facilities (EMI chambers, #1 and #2) and the Yamato EMI conducted test facility are derived with the NIS 81 "Treatment of uncertainty in EMC measurements" 1994.

Estimated site uncertainty values are as follows.

EMI chamber #1 : 4.39dB

EMI chamber #2 : 4.40dB

EMI conducted measurement system : 2.4dB

Detail should be referred to "Treatment of Uncertainty, Calculations and Policy" report, document number TCR 10-0015.

G. Temperature and Humidity

The temperature is controlled within range of 17° to 28°.

The relative humidity is controlled within range of 40% to 70%.

H. Related Submittal(s)/Grant(s)/Notes

The host unit with full peripheral devices including the applying modular as an unintentional radiator is classified as a Digital Device under the FCC Part 15 Subpart B or the Industry Canada Class B Emission Compliance (ICES-003), and subject to SDoC.

1. Bandwidth at 26 dB below / Bandedge

[5150-5250MHz: FCC 15.407(a)(1), RSS 6.2.2q1(i) / q1(iV)(b)]
 [5250-5350MHz: FCC 15.407(a)(2), RSS 6.2.2q1(ii) / q1(iV)(b)]

1.1 Test Procedure

The bandwidth at 26 dB down from the peak of the RF emission was measured with a spectrum analyzer connected to the antenna terminal, while EUT was operating in continuous transmission mode at the appropriate center frequencies (5180 / 5260 / 5320MHz).

The spectrum analyzer was set to:

RBW=300kHz^{*1}, VBW=1MHz^{*2}, Span=50MHz, Sweep= 50ms, Mode= Peak detector

*1: approximately 1% of the emission bandwidth (§15.403(c))

*2: VBW > RBW (To be adjusted accordingly based on the spectrum stability.)

Table 1-1 : 26 dB Bandwidth Test Instruments

Description	Model	Serial Number
Spectrum Analyzer EMI Test Receiver	R&S ESI26	836119/003
Coax cables: - Spectrum Analyzer <=> EUT	Length: 110 cm Loss: 2.2 dB	

Notes: - R&S: Rohde & Schwarz

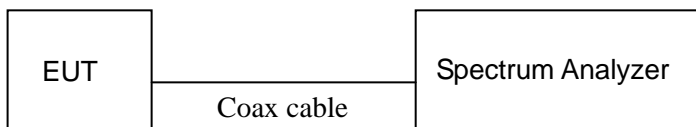

Figure 1: Measurement setup for 26dB bandwidth test

1.2 Measurement Results

Test Date: February 17, 2004

Table 1-2. 26dB bandwidth, TX mode 24Mbps

Center Frequency (MHz)	Lower frequency (MHz)	Upper frequency (MHz)	Bandwidth at 26 dB below (MHz)	Plot data
5180 (ch. 36)	5165.72	5194.48	28.76	Plot 1-1
5260 (ch. 52)	5244.22	5275.58	31.36	Plot 1-2
5320 (ch. 64)	5305.62	5333.42	27.80	Plot 1-3

: the closest frequencies to the bandedge

1.3 Trace Data

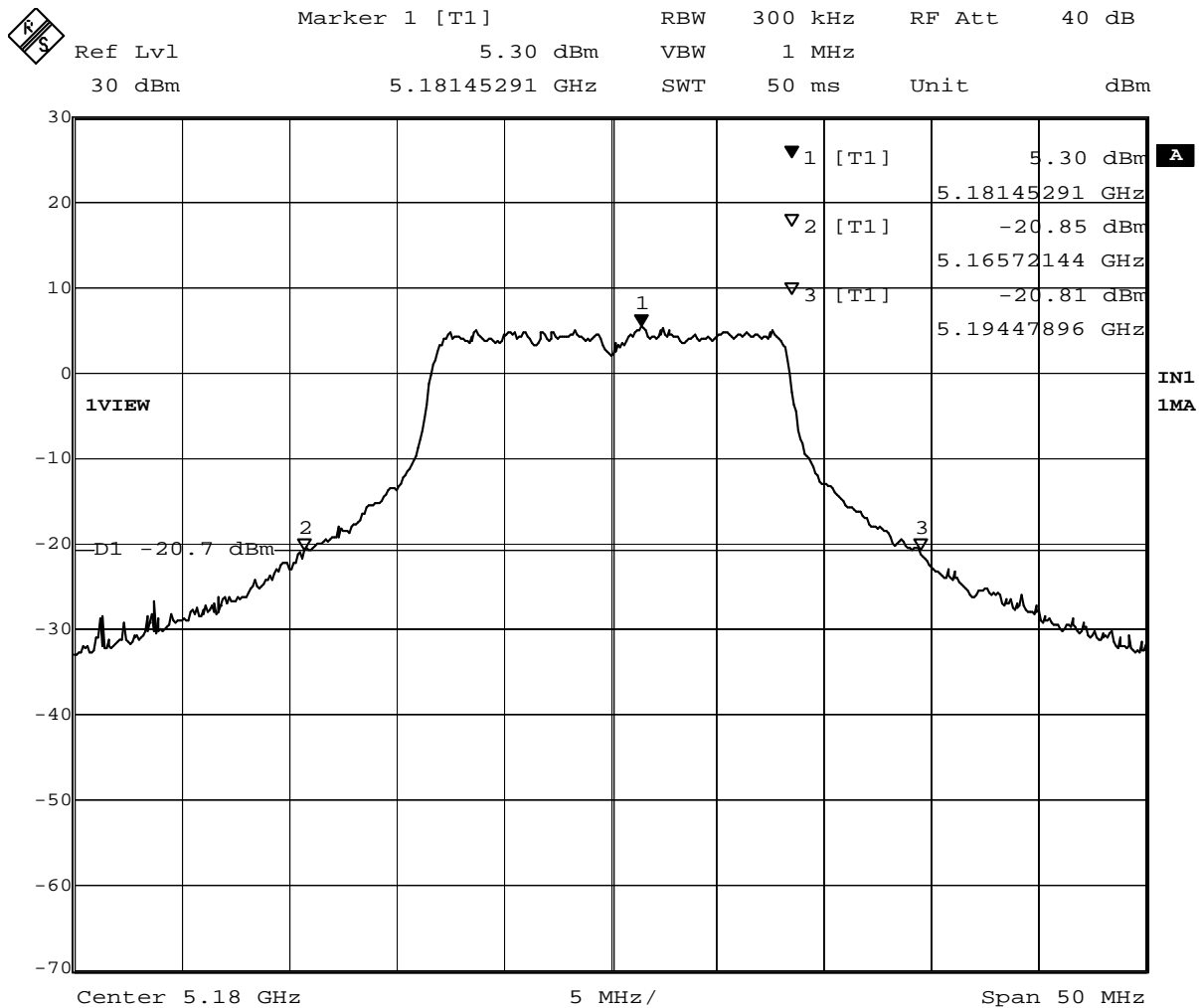

Date: 17.FEB.2004 09:51:44

Plot 1-1. 26dB BW at 5180MHz



Marker 1 [T1] RBW 300 kHz RF Att 40 dB
 Ref Lvl 7.63 dBm VBW 1 MHz
 30 dBm 5.26145291 GHz SWT 50 ms Unit dBm

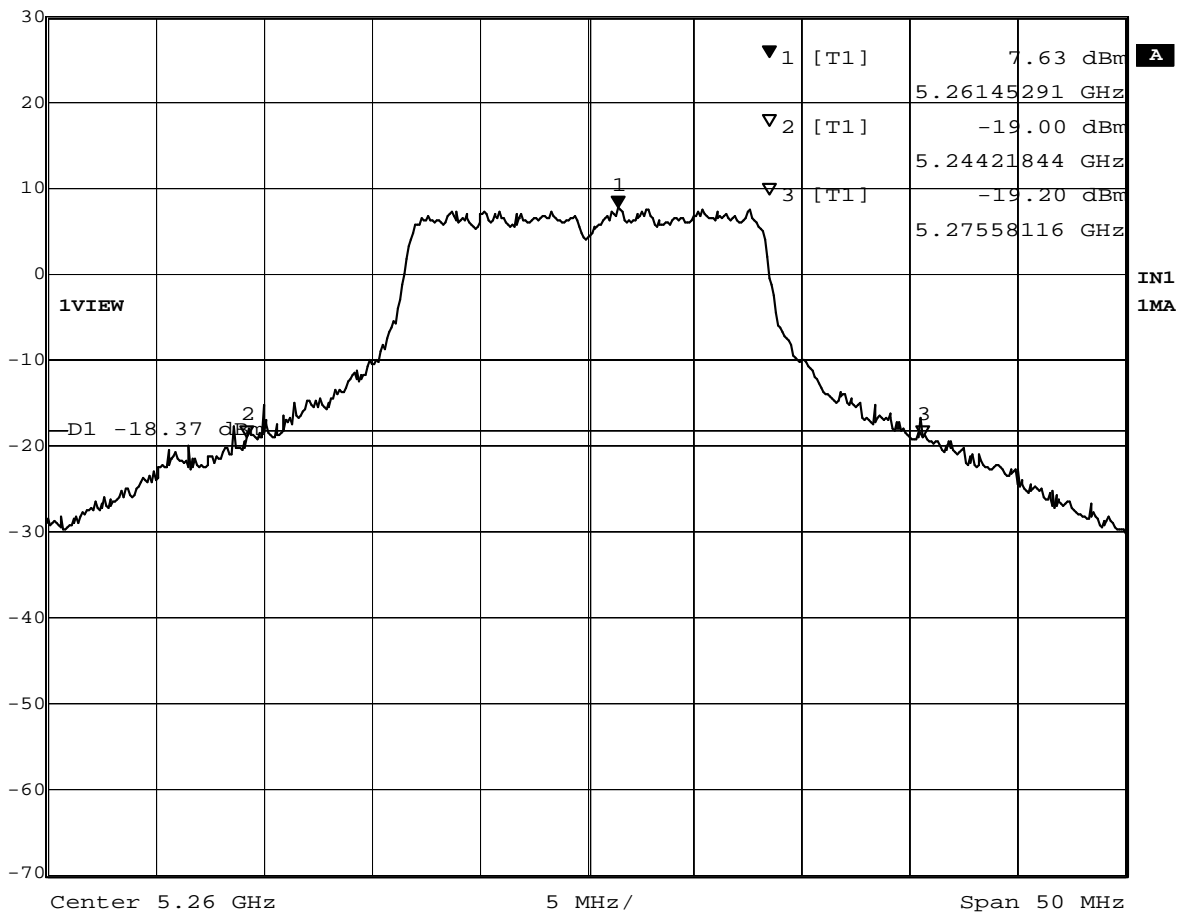

Date: 17.FEB.2004 09:58:08

Plot 1-2. 26dB BW at 5260MHz



Marker 1 [T1] RBW 300 kHz RF Att 40 dB
 Ref Lvl 4.87 dBm VBW 1 MHz
 30 dBm 5.32165331 GHz SWT 50 ms Unit dBm

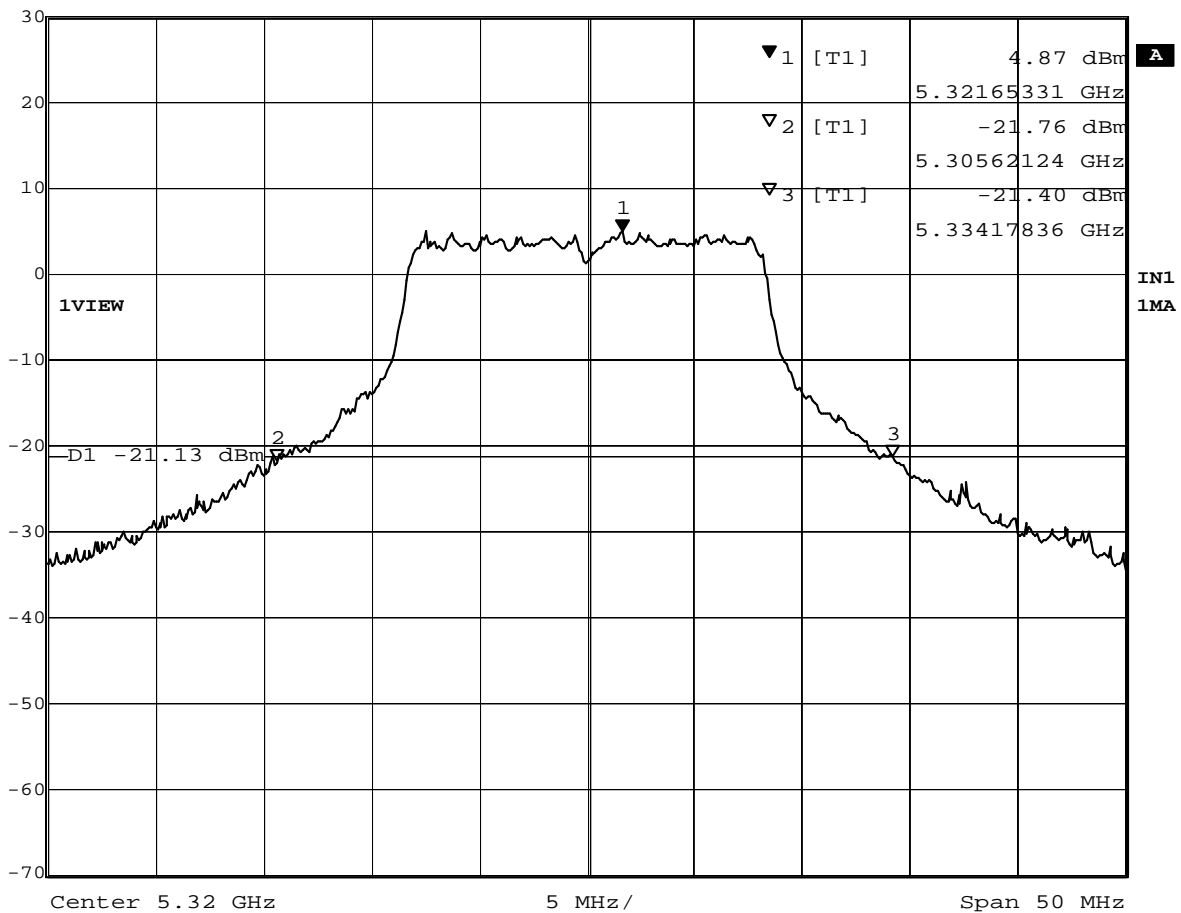

Date: 17.FEB.2004 10:01:52

Plot 1-3. 26dB BW at 5320MHz

2. Peak Conducted Transmit Output Power

[5150-5250MHz: FCC 15.407(a)(1), RSS 6.2.2q1(i) / q1(iV)(b)]
 [5250-5350MHz: FCC 15.407(a)(2), RSS 6.2.2q1(ii) / q1(iV)(b)]

2.1 Test Procedure

The test was performed with two kinds of measurement methods as follows.

- 1) using Power meter
- 2) using Spectrum Analyzer according the Method #3 of the FCC Public Notice, DA 02-2138, August/30/2002

2.1.1 Power Meter measurement method

To find the worse case in the implemented transmission modes in each measuring frequency (low, middle, high), the following test was performed with a power meter.

- A transmitter antenna terminal of EUT was connected to the input of a RF power sensor.
- Measurement was performed while EUT was operating in continuous transmission mode at the appropriate center frequencies. The spectrum of the continuous transmission test mode is shown in the Plot 2-0.

Table 2-1-1: Test Instruments of power meter method

Description	Model	Serial Number
Power Meter	HP 437B	3043U03437
Power Sensor	HP 8481A	US41030582
Coax cables: - Power Sensor <=> EUT	Length: 20 cm Loss: 1.2dB	

Notes: - HP: Hewlett Packard

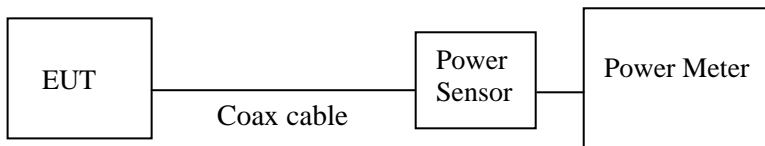

Figure 2-1: Measurement setup of power meter method

2.1.2 Spectrum Analyzer measurement method

The spectrum analyzer was connected to the antenna terminal, while EUT was operating in continuous transmission mode (shown in the Plot 2-0) at the appropriate center frequencies.

The spectrum analyzer was set to :

- VBW= 30kHz ($\geq 1/T$, where T is transmission pulse duration. See Plot 2-0.), RBW=1MHz,
- Span=30-40MHz encompassing the entire 26dB emission bandwidth of the transmission signal,
- Mode= sample detector, Trigger= free run

The band power measurement function was used to measure the peak power of each transmission mode selected by the step 2.1.1. The analyzer computed the peak power by integrating the spectrum across the 26 dB emission bandwidth given by the previous chapter.

Table 2-1-2: Test instruments of spectrum analyzer method

Description	Model	Serial Number
Spectrum Analyzer EMI Test Receiver	R&S ESI26	836119/003
Coax cables: - Spectrum Analyzer <=> EUT	Length: 110 cm Loss: 2.2 dB	

Notes: - R&S: Rohde & Schwarz

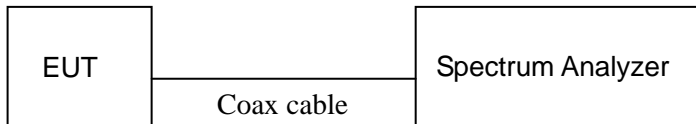
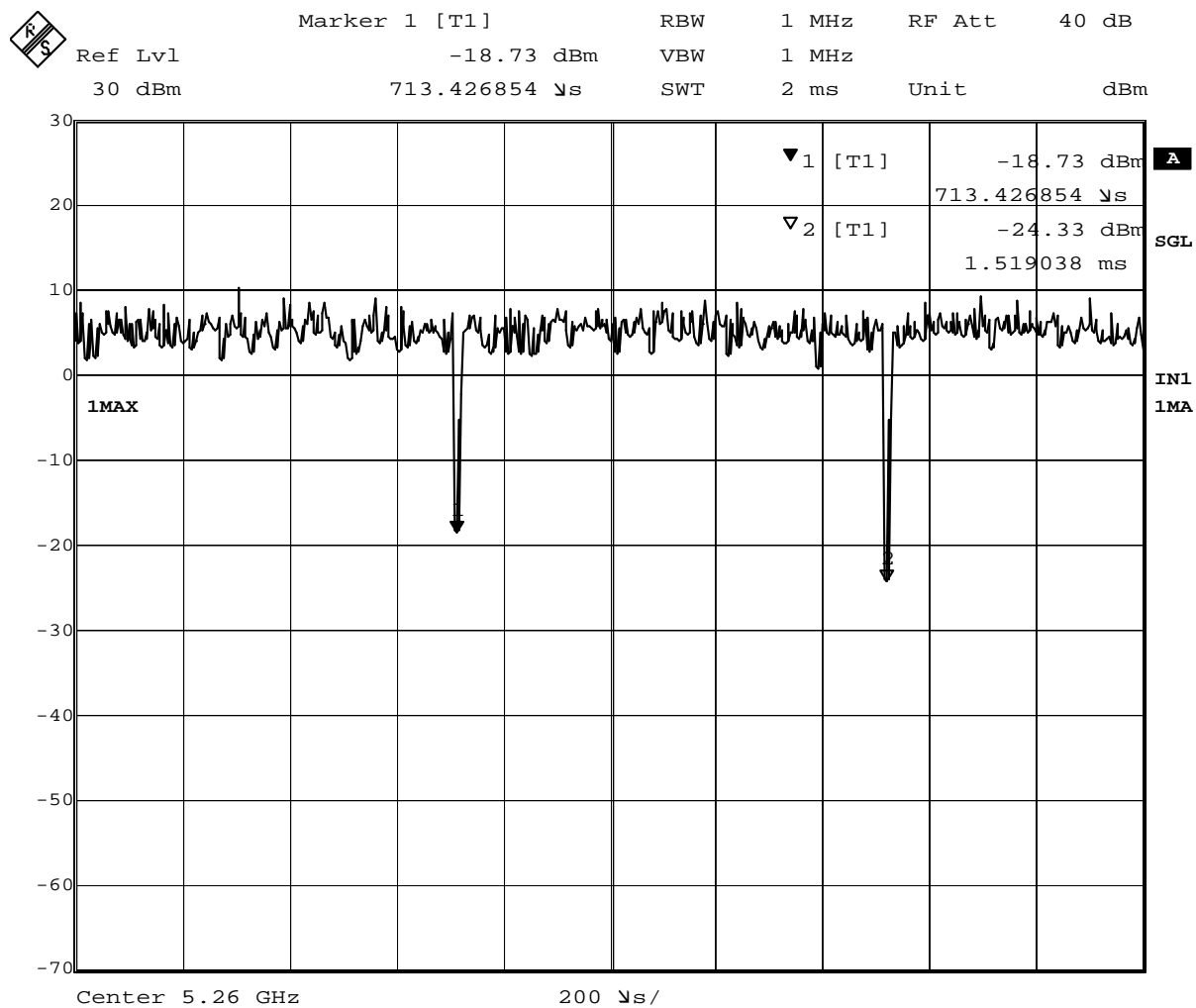

Figure 2-2 : Measurement setup of spectrum analyzer method



Date: 17.FEB.2004 10:08:50

Plot 2-0 Transmission Pulse Duration

2.2 Measurement Results

Test Date: February 17, 2004

Table 2-2-1. Power meter measurement results

Operation Frequency [GHz]	Rated output power (conducted) [dBm]							
	6M bps	9M bps	12M bps	18M bps	24M bps	36M bps	48M bps	54M bps
5.180	13.21	13.23	13.24	13.25	13.27	13.23	13.21	-
specification	14							13
5.260	16.00	16.02	16.04	16.04	16.05	-	-	-
specification	17					15	14	13
5.320	13.12	13.13	13.15	13.16	13.18	13.14	13.11	-
specification	14							13

[Calculation table]

Measured Frequency (MHz)	Power Meter Reading (dBm)	Cable Loss (dB)	Results (dBm)	Limit		Peak antenna gain of EUT (dBi)	EIRP (dBm)	IC limit (dBm)
				FCC (dBm)	IC (dBm)			
5180	13.27	1.2	14.47	17	N/A	2.00	16.47	23
5260	16.05	1.2	17.25	24	24		19.25	30
5320	13.18	1.2	14.38	24	24		16.38	30

Table 2-2-2. Spectrum analyzer measurement results

Measured Frequency (MHz)	Analyzer reading (dBm)	Trace number	Cable Loss (dB)	Results (dBm)	Limit		Peak antenna gain of EUT (dBi)	EIRP (dBm)	IC limit (dBm)
					FCC (dBm)	IC (dBm)			
5180	12.31	Plot 2-1	2.2	14.51	17	N/A	2.00	16.51	23
5260	15.12	Plot 2-2	2.2	17.32	24	24		19.32	30
5320	12.21	Plot 2-3	2.2	14.41	24	24		16.41	30

2.3 Trace Data

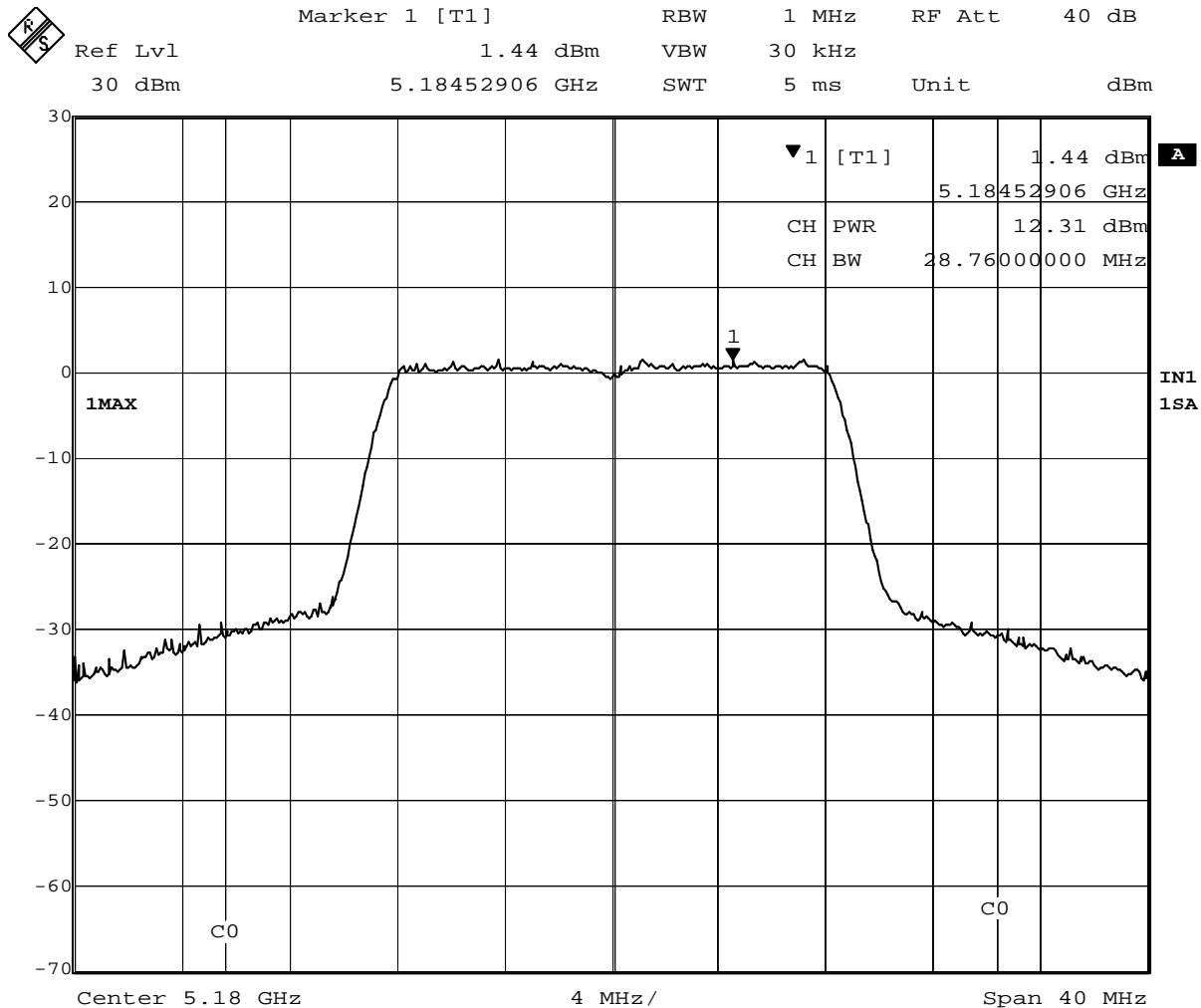

Date: 17.FEB.2004 10:17:46

Plot 2-1 Conducted Peak Power at 5180MHz



Ref Lvl	Marker 1 [T1]	RBW	1 MHz	RF Att	40 dB
30 dBm	4.25 dBm	VBW	30 kHz		
	5.26196393 GHz	SWT	5 ms	Unit	dBm

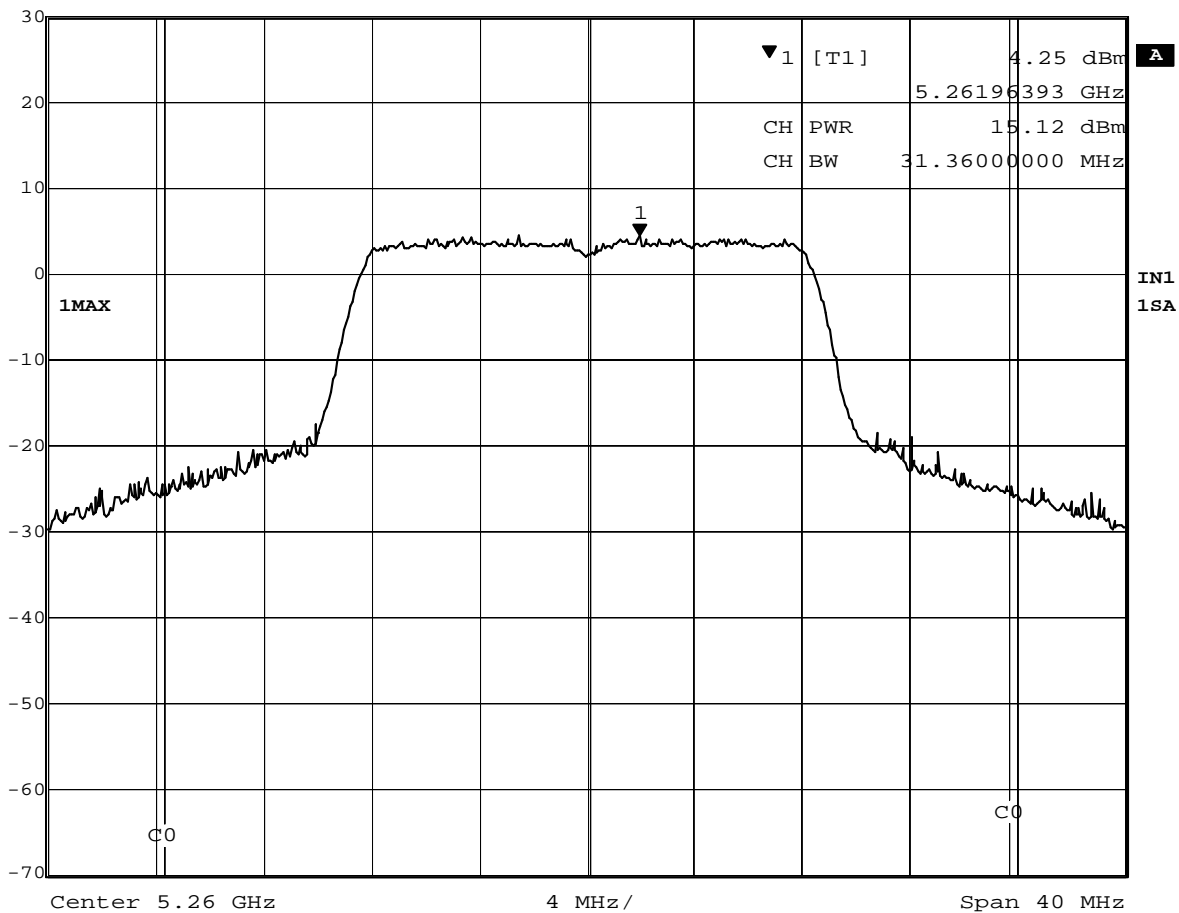

Date: 17.FEB.2004 10:22:00

Plot 2-2 Conducted Peak Power at 5260MHz



Marker 1 [T1] RBW 1 MHz RF Att 40 dB
 Ref Lvl 1.12 dBm VBW 30 kHz
 30 dBm 5.31563126 GHz SWT 5 ms Unit dBm

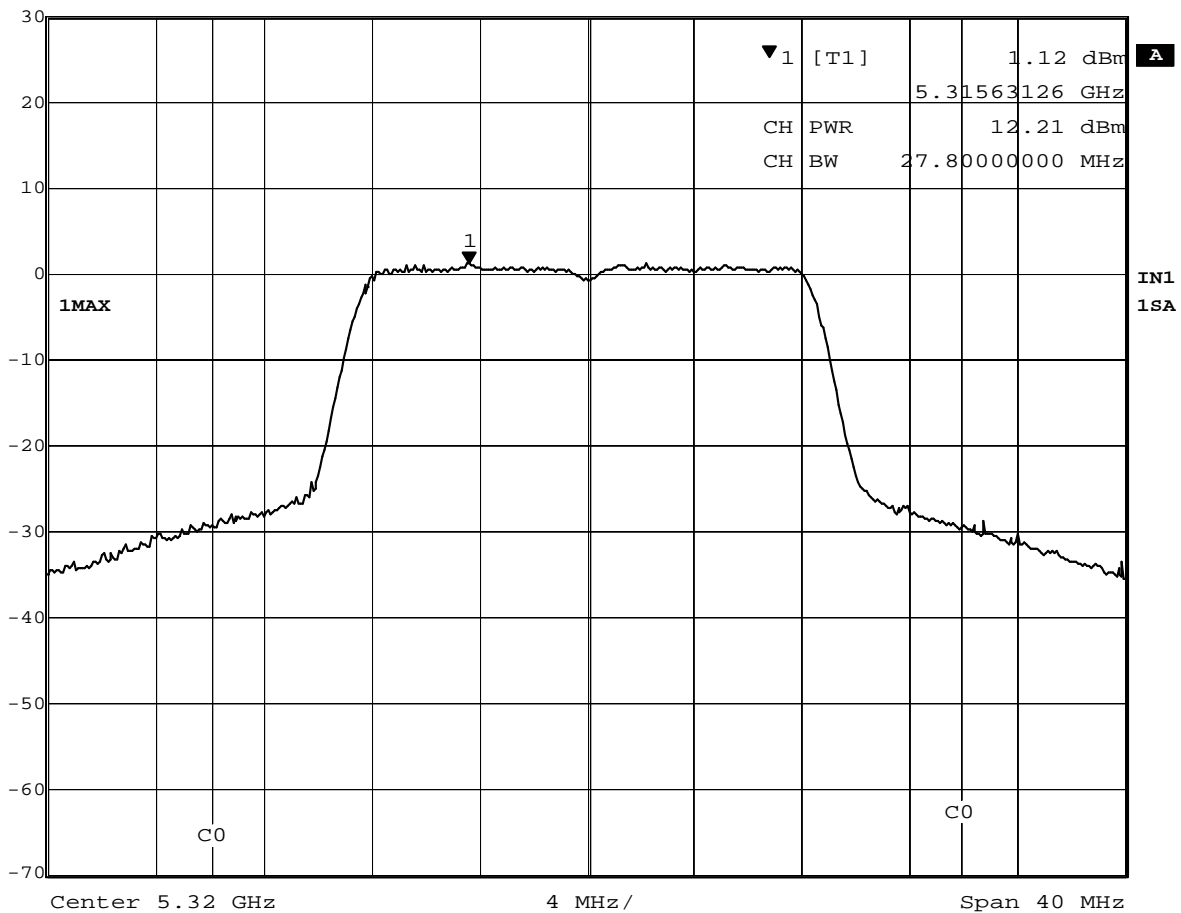

Date: 17.FEB.2004 10:29:07

Plot 2-3 Conducted Peak Power at 5320MHz

3. Peak Power Spectral Density

[5150-5250MHz: FCC 15.407(a)(1), RSS 6.2.2q1(i), (iv)(b)]
 [5250-5350MHz: FCC 15.407(a)(2), RSS 6.2.2q1(ii), (iv)(b)]

3.1 Test Procedure

The spectrum analyzer was connected to the antenna terminal, while EUT was operating in continuous transmission mode at the appropriate center frequencies.

The spectrum analyzer was set to :

RBW= 1MHz, VBW=3MHz, Span=20MHz, Mode= sample detector,

The analyzer averaged 100 traces in averaging mode, then the maker was set to the highest position in the spectrum.

Also the Canadian PPSD was examined with the following spectrum analyzer setting.

RBW= 1MHz, VBW=1MHz, Span=20MHz, Mode= sample detector, averaging off

The test instruments and setup configuration are the same as the Table 2-2 and Figure 2-2.

3.2 Measurement Results

Test Date: February 17, 2004

Table 3-1. Measurement results of PPSD

Measured Frequency (MHz)	Analyzer reading (dBm)	Trace number	Cable Loss (dB)	Results (dBm)	FCC Limit (dBm)	IC Limit q1(ii) (dBm)	Peak Antenna Gain (dBm)	IC EIRP (dBm)	IC Limit q1(i) (dBm)
5181.42	-1.06	Plot 3-1	2.2	1.1	4.0	N/A	2.00	3.1	10
5267.35	1.69	Plot 3-2	2.2	3.9	11.0	11.0			N/A
5325.71	-0.86	Plot 3-3	2.2	1.3	11.0	11.0			N/A

Table 3-2. Measurement results of Canadian PPSD

Measured Frequency (MHz)	Analyzer reading (dBm)	Trace number	Cable Loss (dB)	Results (dBm)	IC Limit q1(iv)(b) 3 + 10logB* (dBm)
5183.79	8.32	Plot 3-4	2.2	10.5	17.59
5261.34	11.24	Plot 3-5	2.2	13.4	17.96
5322.55	8.50	Plot 3-6	2.2	10.7	17.44

* B = 26dB Bandwidth

3.3 Trace Data

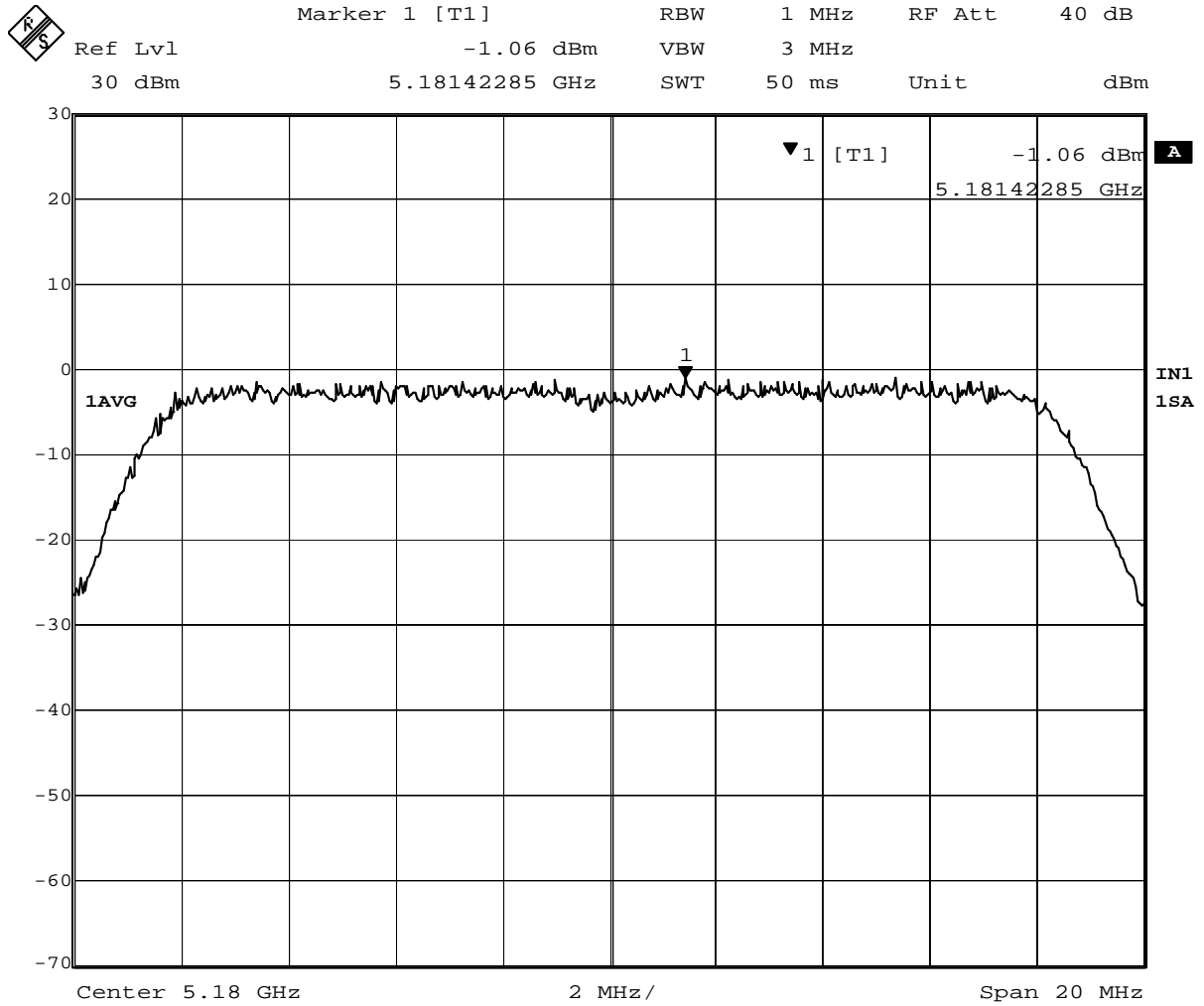

Date: 17.FEB.2004 10:37:27

Plot 3-1 Peak Power Spectral Density at 5180MHz



Ref Lvl	Marker 1 [T1]	RBW	1 MHz	RF Att	40 dB
30 dBm	1.69 dBm	VBW	3 MHz		
	5.26735471 GHz	SWT	50 ms	Unit	dBm

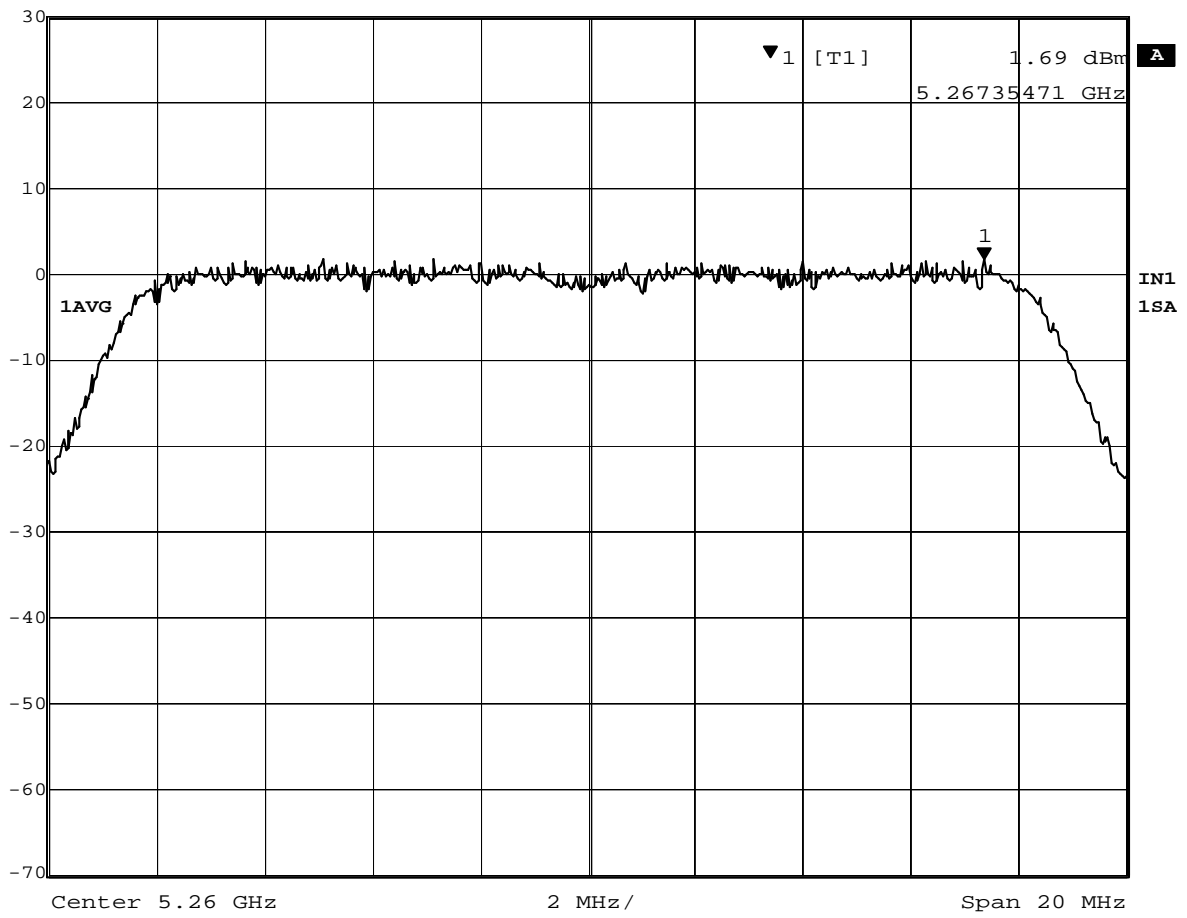

Date: 17.FEB.2004 10:38:30

Plot 3-2 Peak Power Spectral Density at 5260MHz



Ref Lvl	Marker 1 [T1]	RBW	1 MHz	RF Att	40 dB
30 dBm	-0.86 dBm	VBW	3 MHz		
	5.32571142 GHz	SWT	50 ms	Unit	dBm

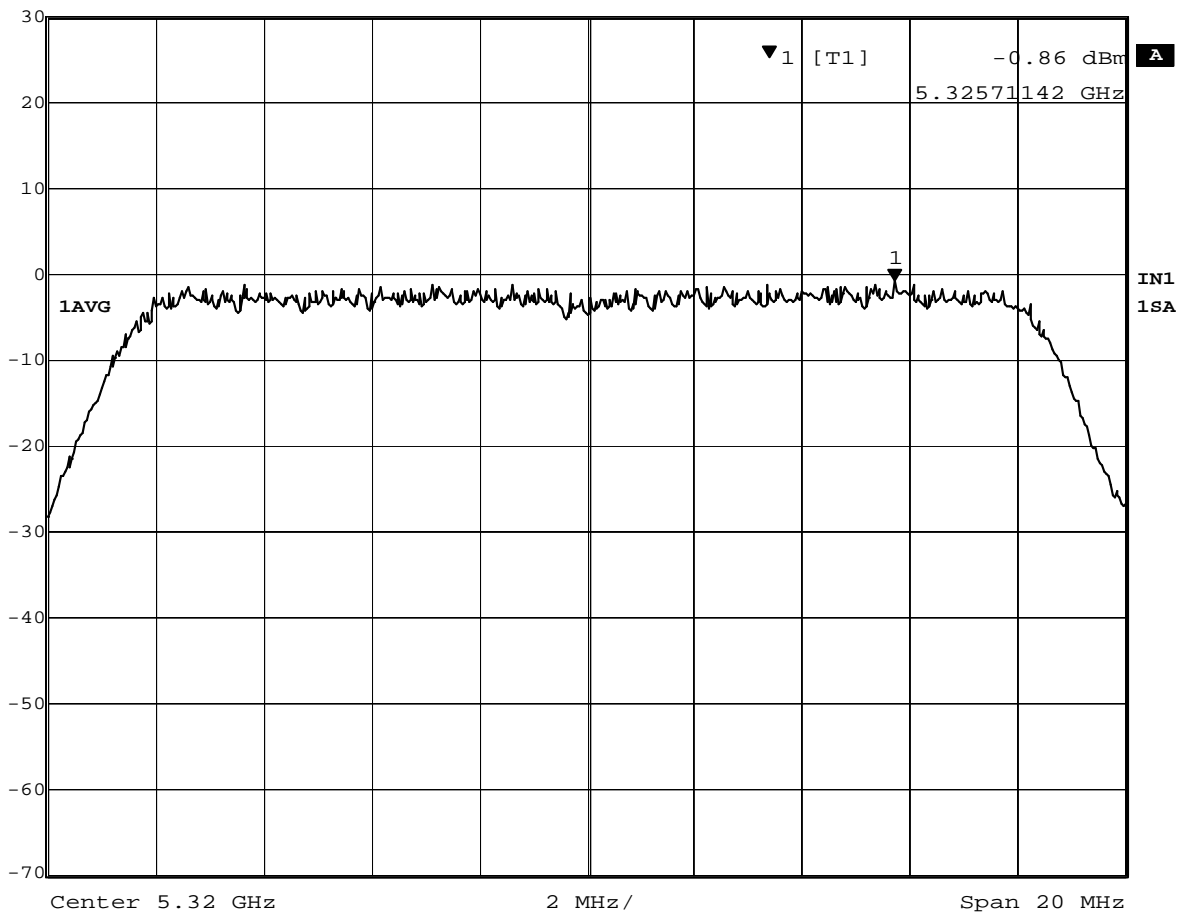

Date: 17.FEB.2004 10:39:31

Plot 3-3 Peak Power Spectral Density at 5320MHz



Ref Lvl	Marker 1 [T1]	RBW	1 MHz	RF Att	40 dB
30 dBm	8.32 dBm	VBW	1 MHz		
	5.18378758 GHz	SWT	50 ms	Unit	dBm

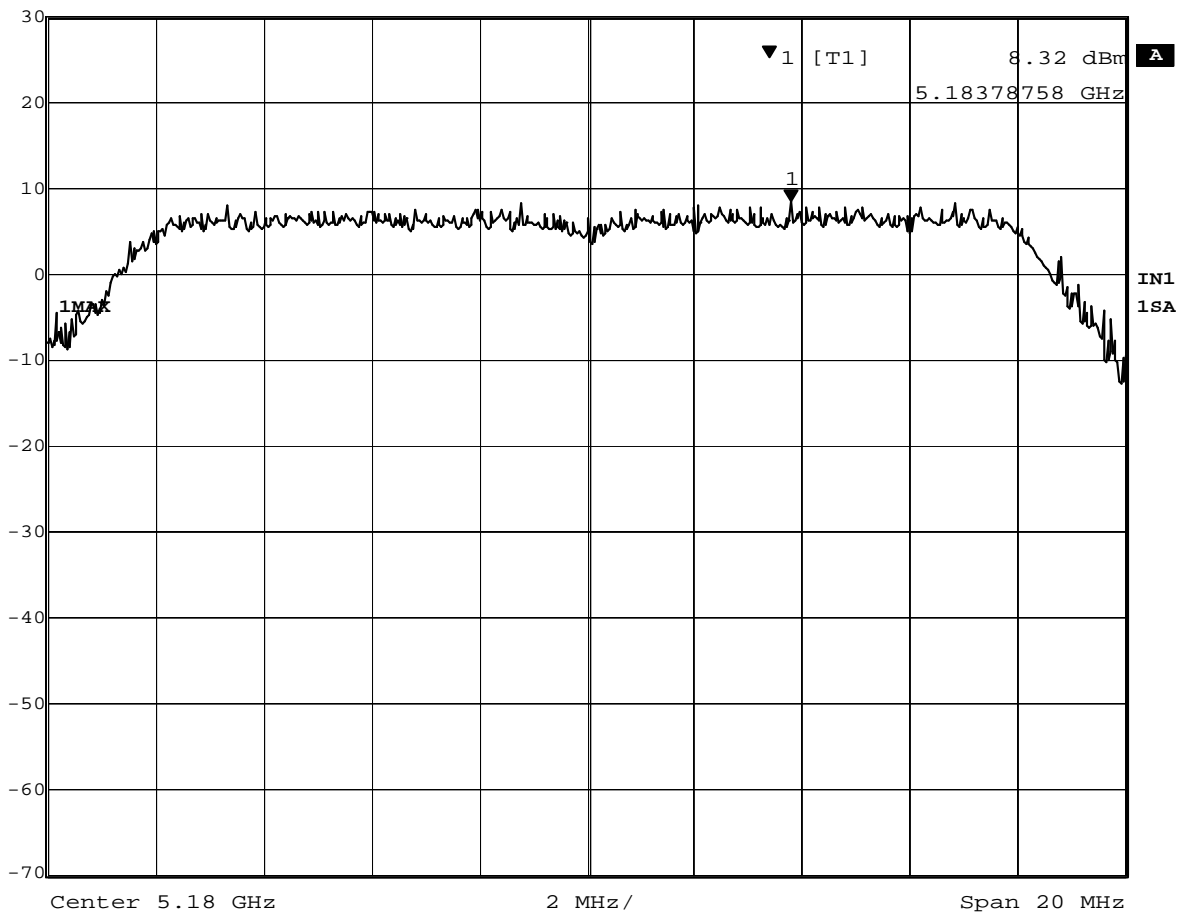

Date: 17.FEB.2004 10:41:41

Plot 3-4 Peak Power Spectral Density at 5180MHz (IC RSS-210)



Ref Lvl	Marker 1 [T1]	RBW	1 MHz	RF Att	40 dB
30 dBm	11.24 dBm	VBW	1 MHz		
	5.26134269 GHz	SWT	50 ms	Unit	dBm

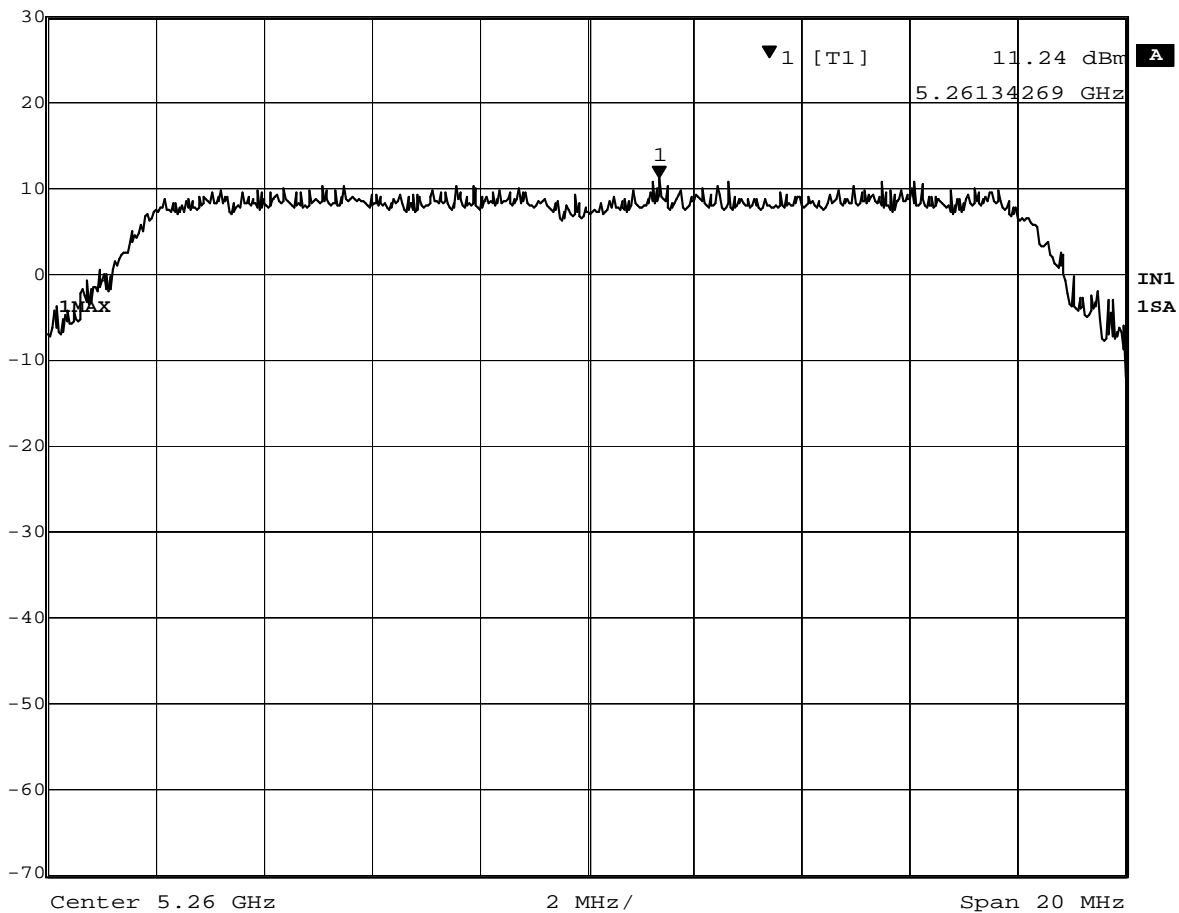

Date: 17.FEB.2004 10:42:46

Plot 3-5 Peak Power Spectral Density at 5260MHz (IC RSS-210)



Ref Lvl	30 dBm	Marker 1 [T1]	5.32254509 GHz	RBW	1 MHz	RF Att	40 dB
				VBW	1 MHz		
				SWT	50 ms	Unit	dBm

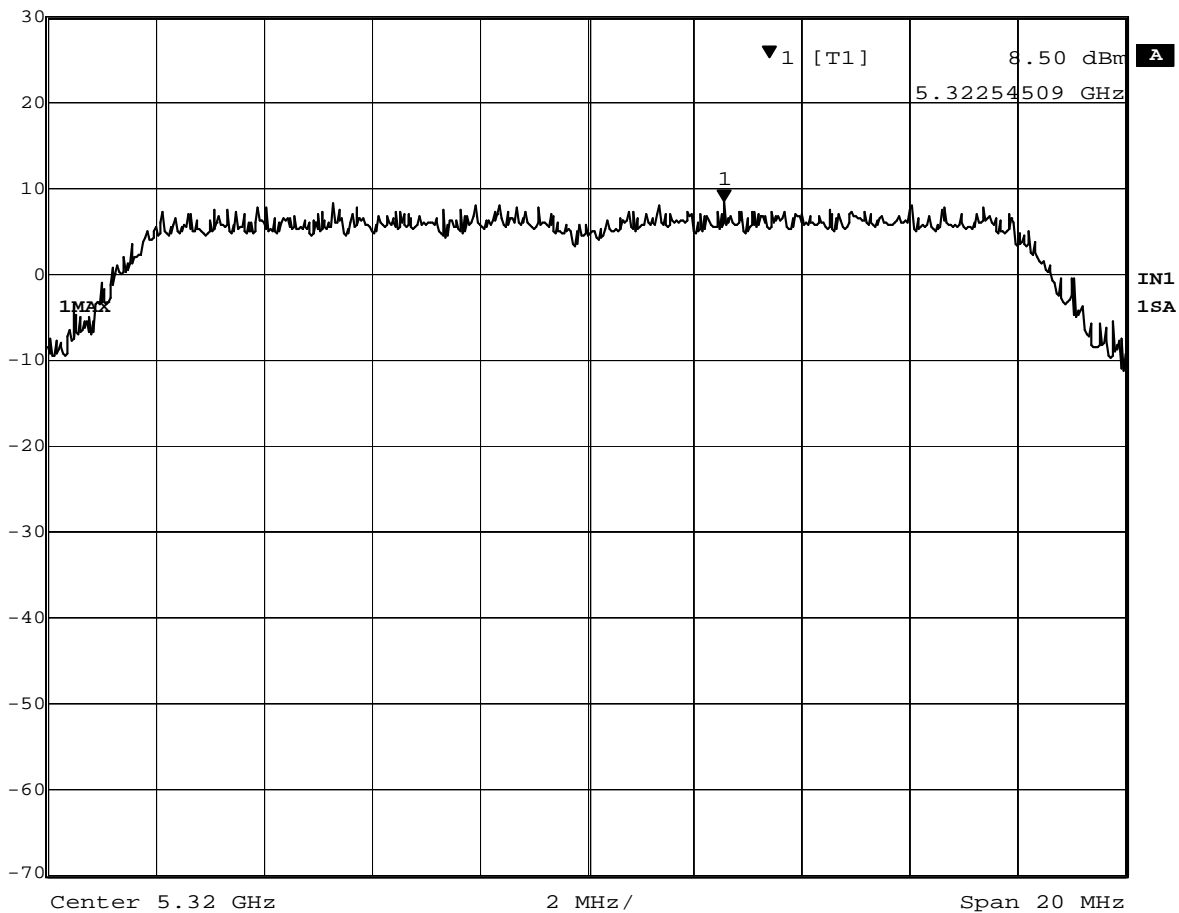

Date: 17.FEB.2004 10:43:56

Plot 3-6 Peak Power Spectral Density at 5320MHz (IC RSS-210)

4. Peak Excursion Ratio

[FCC 15.407(a)(6)]

4.1 Test Procedure

The spectrum analyzer was connected to the antenna terminal, while EUT was operating in continuous transmission mode at the appropriate center frequencies.

- 1st trace :
 The spectrum analyzer was set to :
 RBW= 1MHz, VBW=3MHz, Mode= peak detector and max hold
 then to view.
- 2nd trace :
 The measurement result of the peak conducted power in Chapter 2.1.2 tend to present the similar values to the results of power meter, therefore the same setting of spectrum analyzer as the one for the Chapter 2.1.2 was used for the 2nd trace.
 i.e. VBW= 30kHz, RBW=1MHz, Span=30-40MHz, Trigger= free run,
 Mode= sample detector

The largest difference of amplitude delta between the two trances is the peak excursion.

The test instruments and setup configuration are the same as the Table 2-2 and Figure 2-2.

4.2 Measurement Results

Test Date: February 17, 2004

Table 4-2. Measurement results of Peak Excursion Ratio

Measured Frequency (MHz)	Analyzer Reading delta (dB)	FCC Limit (dB)	Margin (dB)	Trace number
5184.44	10.80	13	2.20	Plot 4-1
5264.21	10.81		2.19	Plot 4-2
5324.21	10.86		2.14	Plot 4-3

4.3 Trace Data

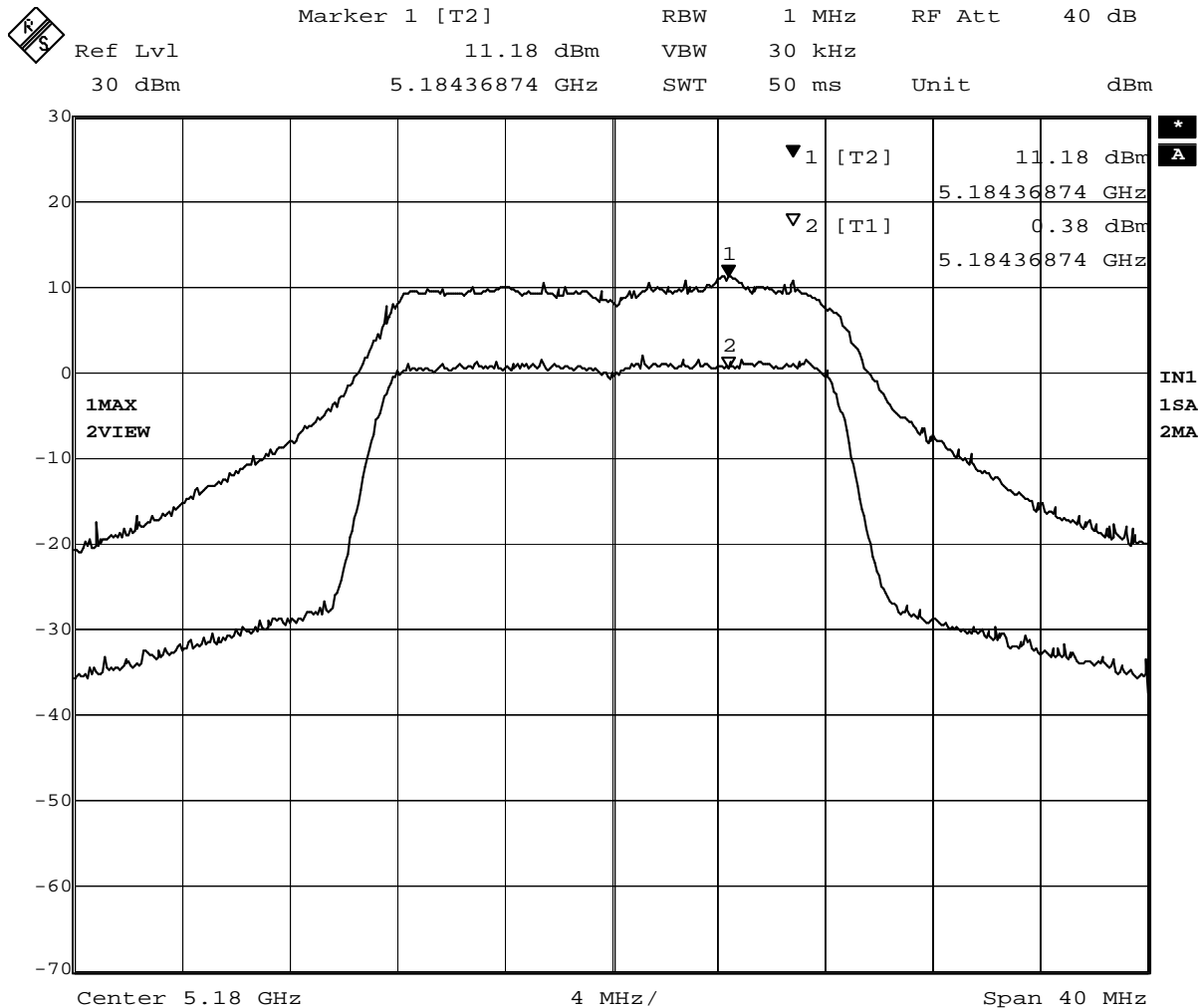

Date: 17.FEB.2004 10:50:50

Plot 4-1 Peak Excursion Ratio at 5180MHz



Marker 1 [T2] RBW 1 MHz RF Att 40 dB
 Ref Lvl 13.77 dBm VBW 30 kHz
 30 dBm 5.26420842 GHz SWT 50 ms Unit dBm

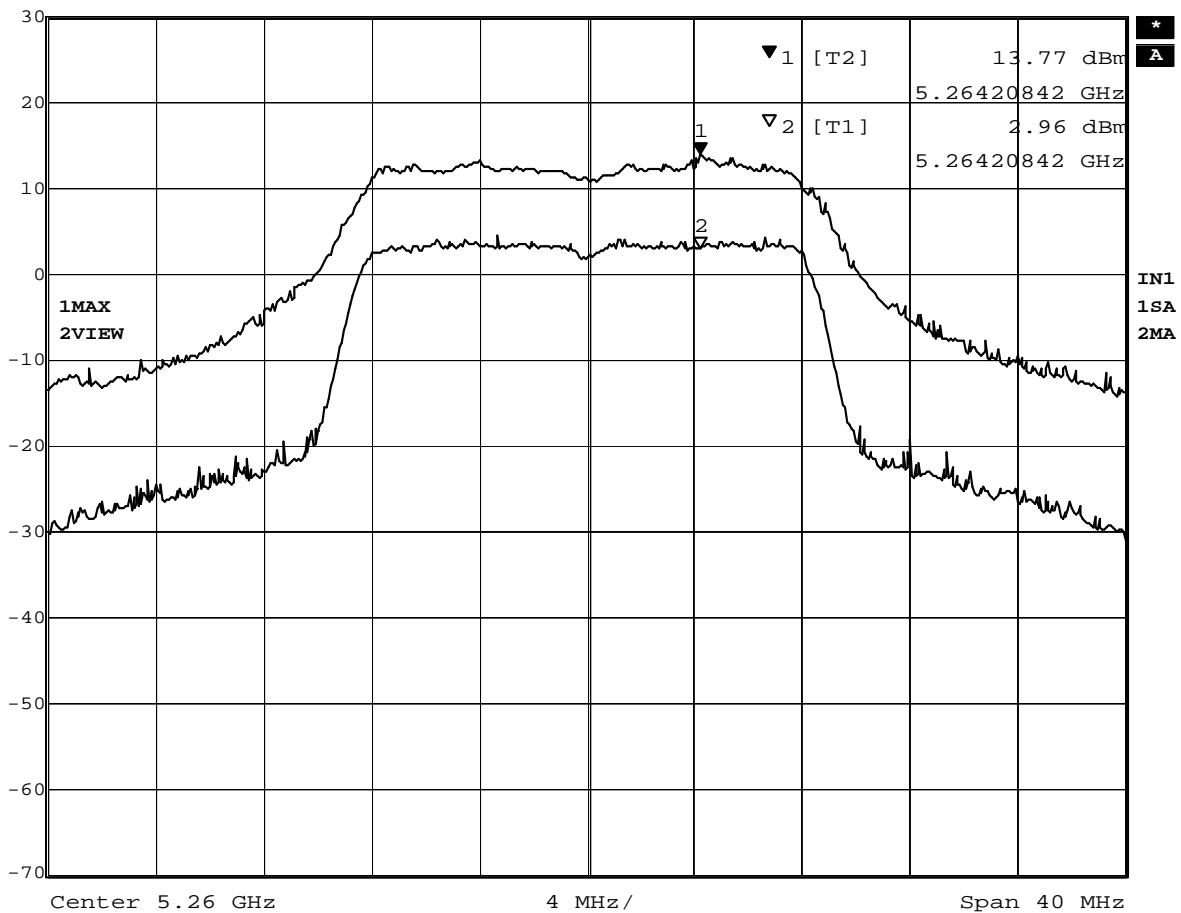

Date: 17.FEB.2004 10:53:47

Plot 4-2 Peak Excursion Ratio at 5260MHz



Marker 1 [T2] RBW 1 MHz RF Att 40 dB
 Ref Lvl 11.18 dBm VBW 30 kHz
 30 dBm 5.32420842 GHz SWT 50 ms Unit dBm

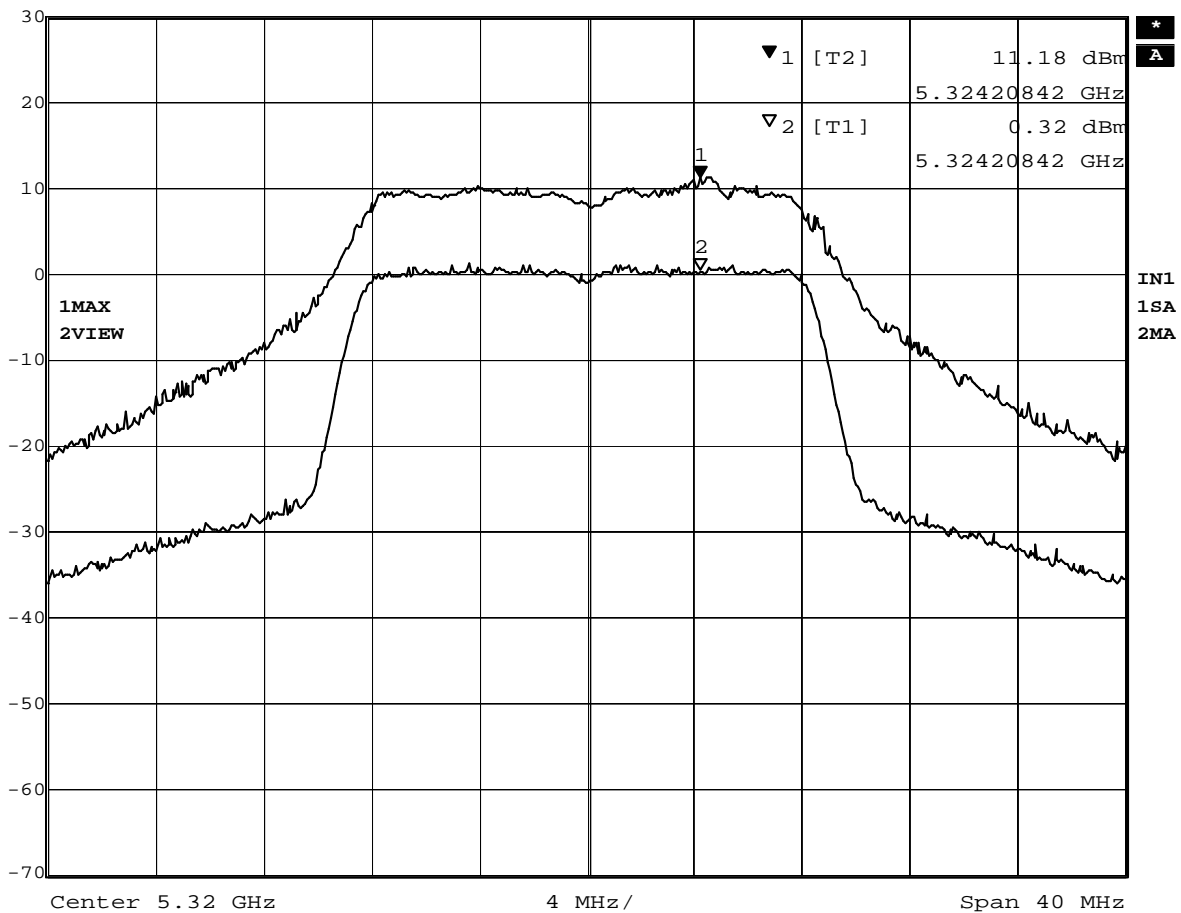

Date: 17.FEB.2004 10:55:36

Plot 4-3 Peak Excursion Ratio at 5320MHz

5. AC WIRELINE CONDUCTED EMISSIONS (150KHz – 30MHz) [FCC 15.207/ 15.407(b)(5), RSS-210 6.2.2(q1)(v) / 6.6 / 7.4]

5.1 Test Procedure

The conducted emissions are measured in the IBM shielded room with a spectrum analyzer in peak hold. Emissions closest to the limit are measured in the quasi-peak mode (QP) with the tuned receiver using a bandwidth of 9KHz. The emissions are maximized further by cable manipulation. The highest emissions relative to the limit are listed.

5.2 Test Instruments and Measurement Setup

Table 5-1. Conducted Emission Test Instrumentation

Description	Model	Serial Number
Computer	IBM 6589-13J	97-15613
Spectrum Analyzer (100Hz-1.5GHz)	HP 85680B	2841A04254
Spectrum Analyzer Display	HP 85662A	2816A16831
Quasi-Peak Adapter	HP 85650A	2811A01156
Receiver (9kHz-30MHz)	R&S ESH3	891806/012
LISN	EMCO 3810/2NM	00022007
Switch/control unit	HP 3488A	2719A17228
Plotter	HP 7550A	2631A33619
Coax cables: - Lisen-L <=> SW/Con.unit (SW100) - Lisen-N <=> SW/Con.unit (SW101) - SW/Con.unit <=> RCVR (Input) - SW/Con.unit<=> Spe Ana.(Signal In)	Length: 4 m 4 m 1 m 1 m	- EMIC-L - EMIC-N - EMIC-R - EMIC-S

Notes: - HP: Hewlett Packard, R&S: Rohde & Schwarz

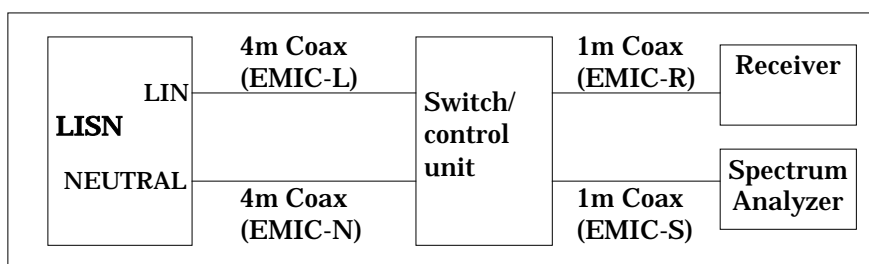

Figure 5. Cables for Conducted Emission Test

5.3 Powerline Voltage Calculation

The powerline voltage is calculated by adding insertion losses of LISN, Cable, Switch control unit and Pulse limiter to the measured reading. All factors are included in the reported data.

$$PV = R + CORR$$

where:

$$PV = \text{Powerline Voltage (dB}\mu\text{V)}$$

$$R = \text{Measured Receiver Input Amplitude (dB}\mu\text{V)}$$

$$CORR = \text{Correction Factor (dB) = LL+CL+SWL+PLL}$$

$$LL = \text{Insertion loss of LISN (dB)}$$

$$CL = \text{Insertion loss of Cable (dB)}$$

$$SWL = \text{Insertion loss of Switch control unit (dB)}$$

$$PLL = \text{Insertion loss of Pulse Limiter (dB)}$$

Given a Receiver input reading of 50.0 dB μ V, LISN loss of 0.6 dB, Cable loss of 0.1dB, Switch control unit loss of 0.1dB and Pulse limiter loss of 0.2dB. The Powerline Voltage of the measured emission is:

$$CORR = 0.6 + 0.1 + 0.1 + 0.2 = 1.0 \text{ (dB)}$$

$$PV = 50.0 + 1.0 = 51.0 \text{ (dB}\mu\text{V)}$$

5.4 Measurement Results

The EUT was found to comply to the limits of FCC Part 15 Subpart E and RSS-210 with a margin of 16.8dB. The 6 highest emissions relative to the limits are reported.

Test Date: February 26, 2004

1) EUT in transmission mode

Table 5-2-1. Ch.36 (5180MHz) TX mode 24Mbps

Frequency (MHz)	QP			AV			CISPR22 QP Limit (dBµV)	CISPR22 AV Limit (dBµV)	Phase
	Measured Reading (dBµV)	Corr. Factor (dB)	Powerline Voltage (dBµV)	Measured Reading (dBµV)	Corr. Factor (dB)	Powerline Voltage (dBµV)			
0.2096	45.9	0.5	46.4	35.1	0.5	35.6	63.2	53.2	Neutral
0.2803	36.3	0.6	36.9	28.5	0.6	29.1	60.8	50.8	Line
0.3474	34.7	0.6	35.3	26.3	0.6	26.9	59.0	49.0	Neutral
0.4186	30.6	0.6	31.2	24.8	0.6	25.4	57.5	47.5	Line
0.4859	27.3	0.6	27.9	25.6	0.6	26.2	56.2	46.2	Line
1.8812	26.0	0.7	26.7	23.3	0.7	24.0	56.0	46.0	Line

Table 5-2-2. Ch.52 (5260MHz) TX mode 24Mbps

Frequency (MHz)	QP			AV			CISPR22 QP Limit (dBµV)	CISPR22 AV Limit (dBµV)	Phase
	Measured Reading (dBµV)	Corr. Factor (dB)	Powerline Voltage (dBµV)	Measured Reading (dBµV)	Corr. Factor (dB)	Powerline Voltage (dBµV)			
0.2095	45.5	0.5	46.0	34.9	0.5	35.4	63.2	53.2	Line
0.3468	34.1	0.6	34.7	26.0	0.6	26.6	59.0	49.0	Neutral
0.4179	30.2	0.6	30.8	24.4	0.6	25.0	57.5	47.5	Line
0.4899	27.2	0.6	27.8	25.4	0.6	26.0	56.2	46.2	Line
0.6954	26.0	0.6	26.6	22.9	0.6	23.5	56.0	46.0	Line
1.6025	26.2	0.6	26.8	22.9	0.6	23.5	56.0	46.0	Line

Table 5-2-3. Ch.64 (5320MHz) TX mode 24Mbps

Frequency (MHz)	QP			AV			CISPR22 QP Limit (dBµV)	CISPR22 AV Limit (dBµV)	Phase
	Measured Reading (dBµV)	Corr. Factor (dB)	Powerline Voltage (dBµV)	Measured Reading (dBµV)	Corr. Factor (dB)	Powerline Voltage (dBµV)			
0.2067	44.1	0.5	44.6	34.1	0.5	34.6	63.3	53.3	Line
0.4182	30.4	0.6	31.0	24.8	0.6	25.4	57.5	47.5	Line
0.4856	27.1	0.6	27.7	25.3	0.6	25.9	56.2	46.2	Line
1.2543	28.9	0.6	29.5	23.1	0.6	23.7	56.0	46.0	Line
1.8846	26.2	0.7	26.9	23.6	0.7	24.3	56.0	46.0	Line
4.7433	33.8	0.7	34.5	24.1	0.7	24.8	56.0	46.0	Neutral

2) EUT in receiving mode

Table 5-2-4. Ch. 52 (5260MHz) **RX** mode

Frequency (MHz)	QP			AV			CISPR22 QP Limit (dBµV)	CISPR22 AV Limit (dBµV)	Phase
	Measured Reading (dBµV)	Corr. Factor (dB)	Powerline Voltage (dBµV)	Measured Reading (dBµV)	Corr. Factor (dB)	Powerline Voltage (dBµV)			
0.2109	44.2	0.5	44.7	34.8	0.5	35.3	63.2	53.2	Line
0.4175	31.6	0.6	32.2	26.3	0.6	26.9	57.5	47.5	Neutral
0.5580	29.2	0.6	29.8	27.0	0.6	27.6	56.0	46.0	Line
0.9776	30.5	0.6	31.1	25.3	0.6	25.9	56.0	46.0	Line
1.6763	27.6	0.6	28.2	24.8	0.6	25.4	56.0	46.0	Line
1.8849	27.7	0.7	28.4	25.4	0.7	26.1	56.0	46.0	Line

6. RESTRICTED BANDS RADIATIONS (30MHz – 1GHz)

[FCC 15.205&209 / 15.407(b)(1),(2),(5),(6)]
 [RSS-210 6.2.1 / 6.2.2(q1)(i),(ii),(v) / 6.3 / 7.3]

6.1 Test Procedure

Preliminary radiated emissions are measured in the semi-anechoic chamber at a 3 meter distance on every azimuth in both horizontal and vertical polarity. The antennas are also scanned in height. The emissions are recorded with a spectrum analyzer in peak hold mode. The identified emissions are further maximized by a cable manipulation. Emissions closest to the limits are measured in the quasi-peak mode with the tuned receiver using a bandwidth of 120kHz. The highest emissions relative to the limit are listed.

6.2 Test Instruments and Measurement Setup

Table 6-1 Radiated Emission Test Instrumentation

Description	Model	Serial Number
Computer	IBM 6868-30J	97-901X3
Spectrum Analyzer (100Hz-1.5GHz) for 30-200MHz	HP 85680B	2601A02634
Spectrum Analyzer Display for 30-200MHz	HP 85662A	2542A12308
Quasi-Peak Adapter for 30-200MHz	HP 85650A	2043A00062
Spectrum Analyzer (100Hz-1.5GHz) for 200-1000MHz	HP 85680B	3019A05156
Spectrum Analyzer Display for 200-1000MHz	HP 85662A	3026A19366
Quasi-Peak Adapter for 200-1000MHz	HP 85650A	2811A01433
Amplifier (100KHz-1.3GHz) - for 30-200MHz - for 200-1000MHz	HP 8447F MITEQ AM-3A	2805A02919 898432
Biconical Antenna (30-200MHz)	EMCO 3108	2536
Log-Periodic Antenna (200-1000MHz)	EMCO 3146	2849
Receiver (20MHz-1.3GHz)	R&S ESVP	892111/030
Switch/control unit	HP 3488A	2719A17226
N-Coax cables: - Bi-coni Ant <=> 10m Cable - 10m Cable <=> Shield Panel - Shield Panel <=> RF Amp - RF Amp <=> Power Splitter - Log-peri Ant <=> 10m Cable - 10m Cable <=> Shield Panel - Shield Panel <=> RF Amp - RF Amp <=> Power Splitter	Length: 9 m 10 m 7 m 0.5m 9 m 10 m 7 m 0.5m	- EM103L01 - EM103L02 - EM103L03 - EM103L04 - EM103H01 - EM103H02 - EM103H03 - EM103H04
Coax cables: - Power Splitter <=> SW/Con.unit (SW110) - Power Splitter <=> SW/Con.unit (SW300) - Power Splitter <=> SW/Con.unit (SW100) - Power Splitter <=> SW/Con.unit (SW301) - SW/Con.unit <=> Receiver (Input) - SW/Con.unit <=> Spe Ana.(Signal In) for 30- 200MHz - SW/Con.unit <=> Spe Ana.(Signal In) for 200-1000MHz	1 m 1 m 1 m 1 m 2 m 2 m 2 m	- EM103L05 - EM103L06 - EM103H05 - EM103H06 - EM1RCV - EM1SPL - EM1SPH

Notes:

- HP: Hewlett Packard, R&S: Rohde & Schwarz

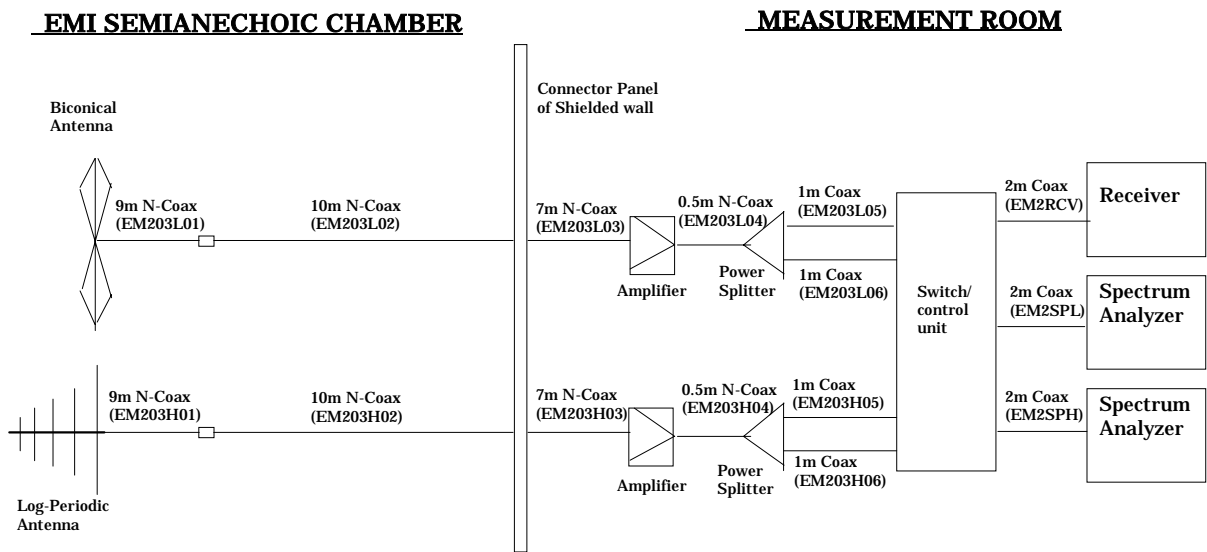

Figure 6 Cables for Radiated Emission Test

6.3 Field Strength Calculation

The field strength is calculated by adding the Antenna Factor and Cable Loss, and subtracting Amplifier Gain from the measured reading. In this test facility, the Antenna Factor, Cable Loss, and Amplifier Gains are loaded into the Rohde & Schwarz Receiver and the corrected field strength can be read directly on the receiver. All factors are included in the reported data.

$$FS = R + AF + CORR$$

where:

- FS = Field Strength
- R = Measured Receiver Input Amplitude
- AF = Antenna Factor
- CORR = Correction Factor = CL - AG
- CL = Cable Loss
- AG = Amplifier Gain

For example:
 Given a Receiver input reading of 51.5dBμV; Antenna Factor of 8.5dB/m; Cable Loss of 1.3dB; and an Amplifier Gain of 26dB. The Field Strength of the measured emission is:

$$FS = 51.5 + 8.5 + 1.3 - 26.0 = 35.3dB\mu V/m$$

Conversion between dBμV/m (or dBμV) and μV/m (or μV) are done as:

$$Level(dB\mu V/m) = 20 \times \text{Log}(Level(\mu V/m))$$

$$40dB\mu V/m = 100\mu V/m$$

$$48dB\mu V/m = 250\mu V/m$$

6.4 Measurement Results

The EUT was found to comply to the limits of FCC Part 15 Subpart E and RSS-210 with a margin of 10.6 dB at 30MHz - 1000MHz band.

The 6 highest emissions relative to the limits are reported.

Test Date: February 23, 2004

Table 6-2-1. Ch.36 (5180MHz) TX mode 24Mbps

Frequency (MHz)	Polarity (H/V)	Measured (dBμV)	Antenna Factor (dB/m)	Corr. Factor (dB)	Field Strength (dBμV/m)	Limit (dBμV/m)	Field Strength (μV/m)	Limit (μV/m)
143.181	V	35.0	12.2	-16.6	30.6	43.5	33.9	150
196.607	H	33.6	13.6	-15.8	31.4	43.5	37.2	150
300.661	H	38.5	14.2	-23.5	29.2	46.0	28.8	200
563.611	V	34.9	18.2	-20.4	32.7	46.0	43.2	200
701.540	V	32.1	21.0	-20.1	33.0	46.0	44.7	200
901.980	V	31.3	22.7	-18.6	35.4	46.0	58.9	200

Table 6-2-2. Ch.52 (5260MHz) TX mode 24Mbps

Frequency (MHz)	Polarity (H/V)	Measured (dBμV)	Antenna Factor (dB/m)	Corr. Factor (dB)	Field Strength (dBμV/m)	Limit (dBμV/m)	Field Strength (μV/m)	Limit (μV/m)
143.181	V	35.0	12.2	-16.6	30.6	43.5	33.9	150
196.607	H	33.6	13.6	-15.8	31.4	43.5	37.2	150
563.611	V	35.2	18.2	-20.4	33.0	46.0	44.7	200
701.537	V	32.6	21.0	-20.1	33.5	46.0	47.3	200
809.979	V	30.0	21.4	-19.1	32.3	46.0	41.2	200
901.976	V	31.1	22.7	-18.6	35.2	46.0	57.5	200

Table 6-2-3. Ch.64 (5320MHz) TX mode 24Mbps

Frequency (MHz)	Polarity (H/V)	Measured (dBμV)	Antenna Factor (dB/m)	Corr. Factor (dB)	Field Strength (dBμV/m)	Limit (dBμV/m)	Field Strength (μV/m)	Limit (μV/m)
143.181	V	34.8	12.2	-16.6	30.4	43.5	33.1	150
196.607	H	33.6	13.6	-15.8	31.4	43.5	37.2	150
563.611	V	35.2	18.2	-20.4	33.0	46.0	44.7	200
701.537	V	33.6	21.0	-20.1	34.5	46.0	53.1	200
809.979	V	29.6	21.4	-19.1	31.9	46.0	39.4	200
901.976	V	30.9	22.7	-18.6	35.0	46.0	56.2	200

Table 6-2-4. Ch.52 (5260MHz) RX mode

Frequency (MHz)	Polarity (H/V)	Measured (dBμV)	Antenna Factor (dB/m)	Corr. Factor (dB)	Field Strength (dBμV/m)	Limit (dBμV/m)	Field Strength (μV/m)	Limit (μV/m)
143.181	V	35.0	12.2	-16.6	30.6	43.5	33.9	150
196.607	H	31.4	13.6	-15.8	29.2	43.5	28.8	150
563.610	V	34.9	18.2	-20.4	32.7	46.0	43.2	200
701.544	V	32.7	21.0	-20.1	33.6	46.0	47.9	200
809.979	V	30.4	21.4	-19.1	32.7	46.0	43.2	200
901.985	V	31.1	22.7	-18.6	35.2	46.0	57.5	200

7. RESTRICTED BANDS RADIATIONS (1GHz – 40GHz)

[FCC 15.205&209 / 15.407(b)(1),(2),(5),(6)]
 [RSS-210 6.2.1 / 6.2.2(q1)(i),(ii),(v) / 6.3 / 7.3]

7.1 Test Procedure

Radiated emissions were measured in the frequency range with 1 GHz to 40GHz in transmitting mode and 1 GHz to 25GHz in receiving mode. All tests were performed in the semi-anechoic chamber at a 3-meter distance (except for the frequency range with 18 GHz to 40 GHz where test distance was reduced to 1 meter) on both horizontal and vertical polarities. The antenna was also scanned in height. The emissions are recorded with a spectrum analyzer in peak hold mode. The identified emissions are further maximized as a function of cable manipulation, azimuth, and antenna height. The emissions closest to the limits are measured in the peak mode with the tuned spectrum analyzer using resolution bandwidth of 1MHz / video bandwidth of 1MHz, and the average setting mode with the tuned spectrum analyzer using resolution bandwidth of 1MHz / video bandwidth of 100Hz or 10Hz. The highest emissions relative to the limit are listed.

7.2 Test Instruments and Measurement Setup

Table 7 Radiated Emission Test Instrumentation (1GHz – 40GHz)

Description	Model	Serial Number
Spectrum Analyzer EMI Test Receiver	R&S ESI26	836119/003
Spectrum Analyzer	HP 8563E	3416A02248
Harmonic Mixer (26.5 – 40GHz)	Agilent 11970A	011269-001
Amplifier (1 - 26.5GHz)	HP 8449B	3008A00582
Amplifier (26.5 – 40GHz)	Agilent 83051A	3950M00193
Horn Antenna (1 - 18GHz)	EMCO 3115	9903-5774
Horn Antenna (3.95 – 5.85GHz)	EMCO 3160-5	1099
Horn Antenna (5.85 – 8.2GHz)	EMCO 3160-6	9712-1044
Horn Antenna (8.2 – 12.4GHz)	EMCO 3160-7	1156
Horn Antenna (12.4 – 18GHz)	EMCO 3160-8	1143
Horn Antenna (18 - 26.5GHz)	EMCO 3160-9	0004-1202
Horn Antenna (26.5 - 40GHz)	EMCO 3160-10	1175
Coaxial cables:	Length:	
- Horn Ant <=> RF Amp. (1-18GHz)	6 m	- EM206SCO
- RF Amp.<=>Spectrum Analyzer (1-12.4GHz)	16 m	- GEM0101
- RF Amp.<=>Spectrum Analyzer (12.4-18GHz)	3m	- SF102-20166
- Horn Ant <=> RF Amp. (18-40GHz)	3m	- SF102-20167
- RF Amp. <=> Spectrum Analyzer (18-40GHz)	1m	- SF102-21105

Notes: - HP: Hewlett Packard, R&S: Rohde & Schwarz

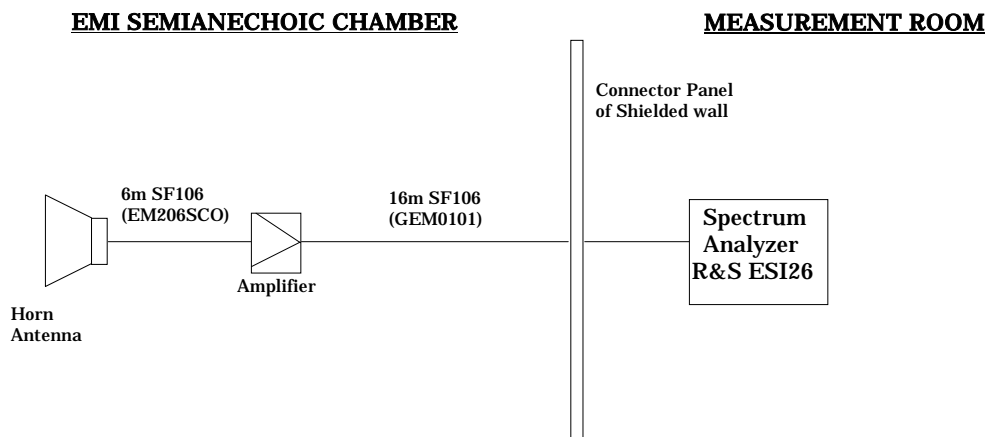

Figure 7-1. Cables for Radiated Emission Test (1 – 12.4 GHz)

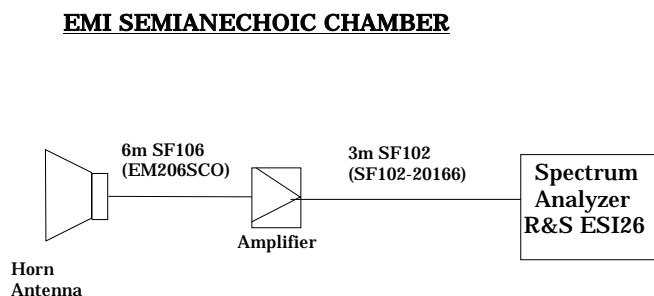

Figure 7-2. Cables for Radiated Emission Test (12.4 - 18GHz)

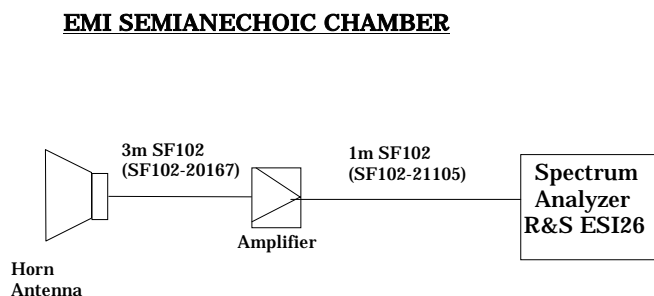

Figure 7-3. Cables for Radiated Emission Test (18 - 26.5GHz)

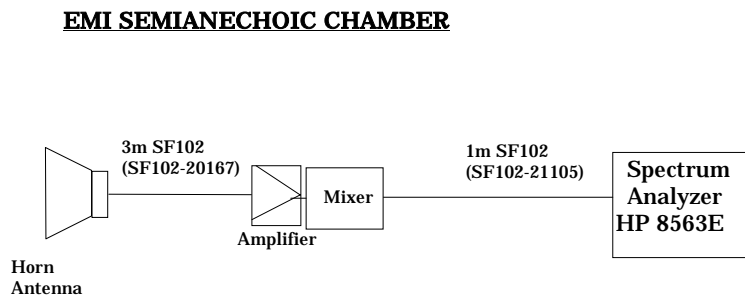

Figure 7-4. Cables for Radiated Emission Test (26.5 - 40GHz)

7.3 Field Strength Calculation

The field strength is calculated by adding the Antenna Factor and Cable Loss, and subtracting Amplifier Gain from the measured reading. All factors are included in the reported data.

$$FS = R + AF + CORR - FO$$

where:

- FS = Field Strength
- R = Measured Spectrum analyzer Input Amplitude
- AF = Antenna Factor
- CORR = Correction Factor = CL-AG
- CL = Cable Loss
- AG = Amplifier Gain
- FO = Distance Falloff Factor

For example:

Given a Spectrum Analyzer input reading of 51.5 dBμV; Antenna Factor of 8.5 dB/m; Cable Loss of 1.3 dB; Falloff Factor of 0 dB; and an Amplifier Gain of 26 dB. The Field Strength of the measured emission is:

$$FS = 51.5 + 8.5 + 1.3 - 26 - 0.0 = 35.6 \text{ dB}\mu\text{V/m}$$

Conversions between dBμV/m (or dBμV) and μV/m (or μV) are done as :

- Level(dBμV/m) = 20 × Log (Level(μV/m))
- 40 dBμV/m = 100 μV/m
- 48 dBμV/m = 250 μV/m

7.4 Limits

Table 7-1. Limits for EIRP emissions

Limit for emissions in restricted bands FCC 15.205&209 / RSS-210 6.3&7.3	54 dBμV/m (average)	74 dBμV/m (peak)
Limit for emissions in non_restricted bands FCC 15.407(b)(1)&(2) / RSS-210 (q1)(i)&(ii)	EIRP 68.2 dBμV/m (-27 dBm/MHz)	

7.5 Measurement Results

The EUT was found to comply to the limits of FCC Part 15 Subpart E and RSS-210 with a margin of 7.1 dB. The measurement was done for the frequency range of 1 GHz to 40 GHz in TX mode and 1 GHz to 25GHz in RX mode.

Test Date: February 23, 24, 25 and 27, 2004

Table 7-2-1. Ch.36 (5180MHz) **TX** mode 24Mbps

Frequency (GHz)	Polarity (H/V)	Measured (dBμV) (<i>peak</i>)	Measured (dBμV) (<i>average</i>)	Antenna Factor (dB/m)	Corr. Factor (dB)	Falloff Factor (dB)	Field Strength (dBμV/m) (<i>peak</i>)	FCC Limit (dBμV/m) (<i>peak</i>)	Field Strength (dBμV/m) (<i>average</i>)	FCC Limit (dBμV/m) (<i>average</i>)
OB										
5.185 bandedge	H	97.5	85.7	33.7	-26.5	0.0	104.7	N/A	92.9	N/A
5.120	H	48.9	36.1	33.7	-26.5	0.0	56.1	74.0	43.3	54.0
5.149	H	53.6	37.2	33.6	-26.5	0.0	60.7	74.0	44.3	54.0
5.150	H	55.3	37.7	33.6	-26.5	0.0	62.4	74.0	44.8	54.0
1.062	V	50.7	-	24.6	-32.0	0.0	43.3	74.0	-	54.0
1.160	V	52.4	-	24.6	-31.7	0.0	45.3	74.0	-	54.0
1.196	V	55.2	-	25.2	-31.6	0.0	48.8	74.0	-	54.0
1.325	V	53.5	-	25.6	-31.3	0.0	47.8	74.0	-	54.0
6.216	H	47.3	-	29.9	-25.6	0.0	51.6	68.2	-	NRB

Note: OB means “operation band” (5150-5250MHz).
 NRB means “non restricted band”: The limit of FCC Part 15.407(b)(1),(2) and RSS-210 6.2.2(q1)(I),(ii) apply.

Table 7-2-2. Ch.52 (5260MHz) **TX** mode 24Mbps

Frequency (GHz)	Polarity (H/V)	Measured (dBμV) (<i>peak</i>)	Measured (dBμV) (<i>average</i>)	Antenna Factor (dB/m)	Corr. Factor (dB)	Falloff Factor (dB)	Field Strength (dBμV/m) (<i>peak</i>)	FCC Limit (dBμV/m) (<i>peak</i>)	Field Strength (dBμV/m) (<i>average</i>)	FCC Limit (dBμV/m) (<i>average</i>)
OB										
5.262 bandedge	H	100.3	89.0	33.6	-26.4	0.0	107.5	N/A	96.2	N/A
5.134	H	49.1	35.5	33.7	-26.5	0.0	56.3	74.0	42.7	54.0
5.350	H	48.9	36.8	33.9	-26.3	0.0	56.5	74.0	44.4	54.0
5.377	H	49.8	37.3	33.9	-26.3	0.0	57.4	74.0	44.9	54.0
1.028	V	50.4	-	24.3	-32.2	0.0	42.5	74.0	-	54.0
1.162	V	51.1	-	24.6	-31.7	0.0	44.0	74.0	-	54.0
1.198	V	53.4	-	25.2	-31.6	0.0	47.0	74.0	-	54.0
1.333	V	49.0	-	25.2	-31.3	0.0	42.9	74.0	-	54.0
6.313	H	43.7	-	30.0	-25.7	0.0	48.0	68.2	-	NRB
10.525	V	36.8	-	33.5	-20.8	0.0	49.5	68.2	-	NRB

Note: OB means “operation band” (5250-5350MHz).
 NRB means “non restricted band”: The limit of FCC Part 15.407(b)(1),(2) and RSS-210 6.2.2(q1)(I),(ii) apply.

Table 7-2-3. Ch.64 (5320MHz) **TX** mode 24Mbps

Frequency (GHz)	Polarity (H/V)	Measured (dBμV) (<i>peak</i>)	Measured (dBμV) (<i>average</i>)	Antenna Factor (dB/m)	Corr. Factor (dB)	Falloff Factor (dB)	Field Strength (dBμV/m) (<i>peak</i>)	FCC Limit (dBμV/m) (<i>peak</i>)	Field Strength (dBμV/m) (<i>average</i>)	FCC Limit (dBμV/m) (<i>average</i>)
OB										
5.324 bandedge	H	96.7	85.2	33.7	-26.4	0.0	104.0	N/A	92.5	N/A
5.350	H	55.0	39.3	33.9	-26.3	0.0	62.6	74.0	46.9	54.0
5.351	H	56.9	39.0	33.9	-26.3	0.0	64.5	74.0	46.6	54.0
5.389	H	50.5	38.0	33.9	-26.2	0.0	58.2	74.0	45.7	54.0
1.128	V	53.7	-	24.5	-31.8	0.0	46.4	74.0	-	54.0
1.200	V	54.5	-	25.2	-31.6	0.0	48.1	74.0	-	54.0
1.216	V	50.9	-	25.2	-31.5	0.0	44.6	74.0	-	54.0
1.327	V	53.3	-	25.6	-31.3	0.0	47.6	74.0	-	54.0
6.385	H	42.6	-	29.9	-25.7	0.0	46.8	68.2	-	NRB
10.645	H	35.5	-	33.5	-20.7	0.0	48.3	74.0	-	54.0

*Note: OB means “operation band” (5250-5350MHz).
 NRB means “non restricted band”: The limit of FCC Part 15.407(b)(1),(2) and RSS-210 6.2.2(q1)(I),(ii) apply.

Table 7-2-4 Ch.52 (5260MHz) **RX** mode

Frequency (GHz)	Polarity (H/V)	Measured (dBμV) (<i>peak</i>)	Measured (dBμV) (<i>average</i>)	Antenna Factor (dB/m)	Corr. Factor (dB)	Falloff Factor (dB)	Field Strength (dBμV/m) (<i>peak</i>)	FCC Limit (dBμV/m) (<i>peak</i>)	Field Strength (dBμV/m) (<i>average</i>)	FCC Limit (dBμV/m) (<i>average</i>)
1.012	V	49.5	-	24.3	-32.2	0.0	41.6	74.0	-	54.0
1.128	V	47.8	-	24.5	-31.8	0.0	40.5	74.0	-	54.0
1.164	V	48.9	-	24.6	-31.7	0.0	41.8	74.0	-	54.0
1.216	V	48.2	-	25.2	-31.5	0.0	41.9	74.0	-	54.0

Note: NRB means “non restricted band”: The limit of FCC Part 15.407(b)(1),(2) and RSS-210 6.2.2(q1)(I),(ii) apply.

7.6 Trace Data



Marker 1 [T1] RBW 1 MHz RF Att 20 dB
 Ref Lvl 97.46 dBμV VBW 1 MHz
 117 dBμV 5.18460922 GHz SWT 5 ms Unit dBμV

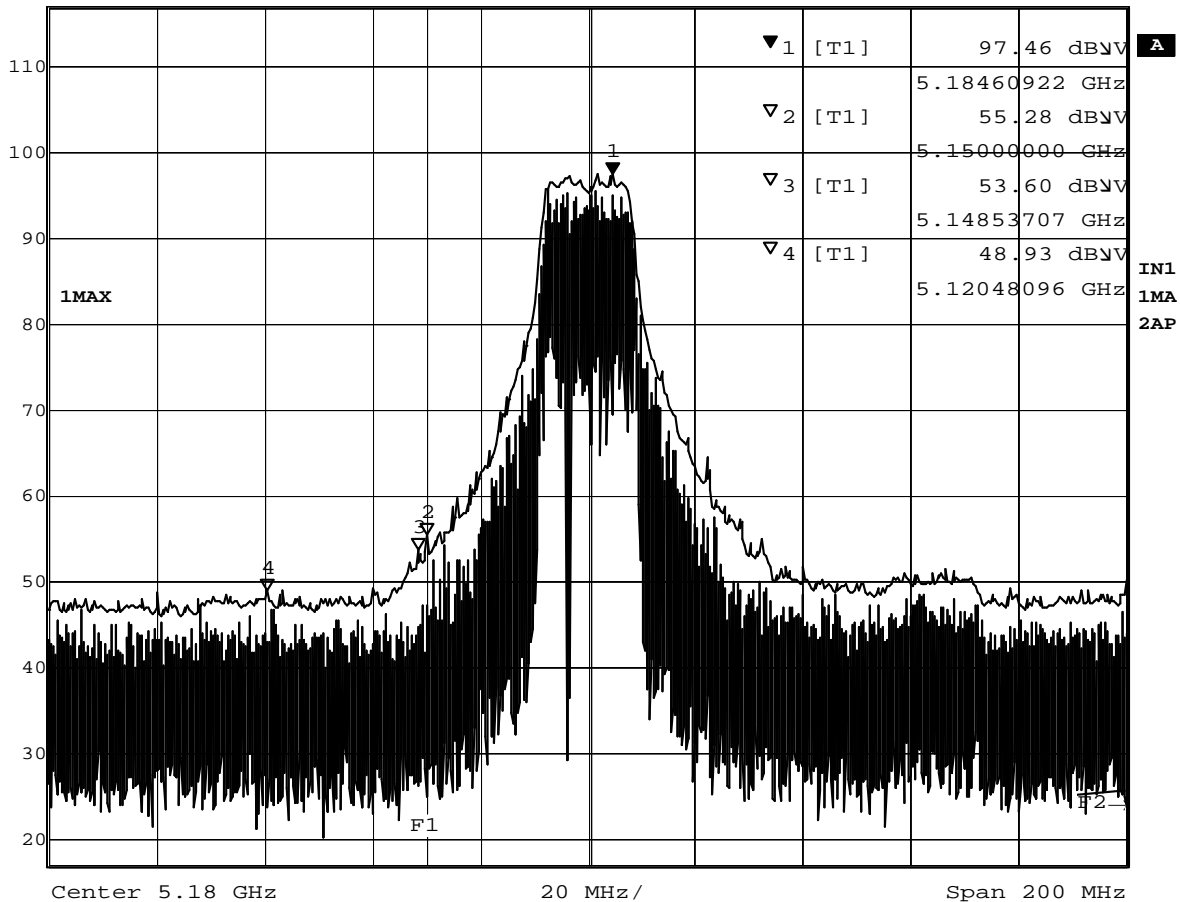

Date: 23.FEB.2004 18:50:49

Plot 7-1-1 5180MHz TX mode (Peak)



Marker 1 [T1] RBW 1 MHz RF Att 20 dB
 Ref Lvl 85.74 dBμV VBW 10 Hz
 117 dBμV 5.17498998 GHz SWT 50 s Unit dBμV

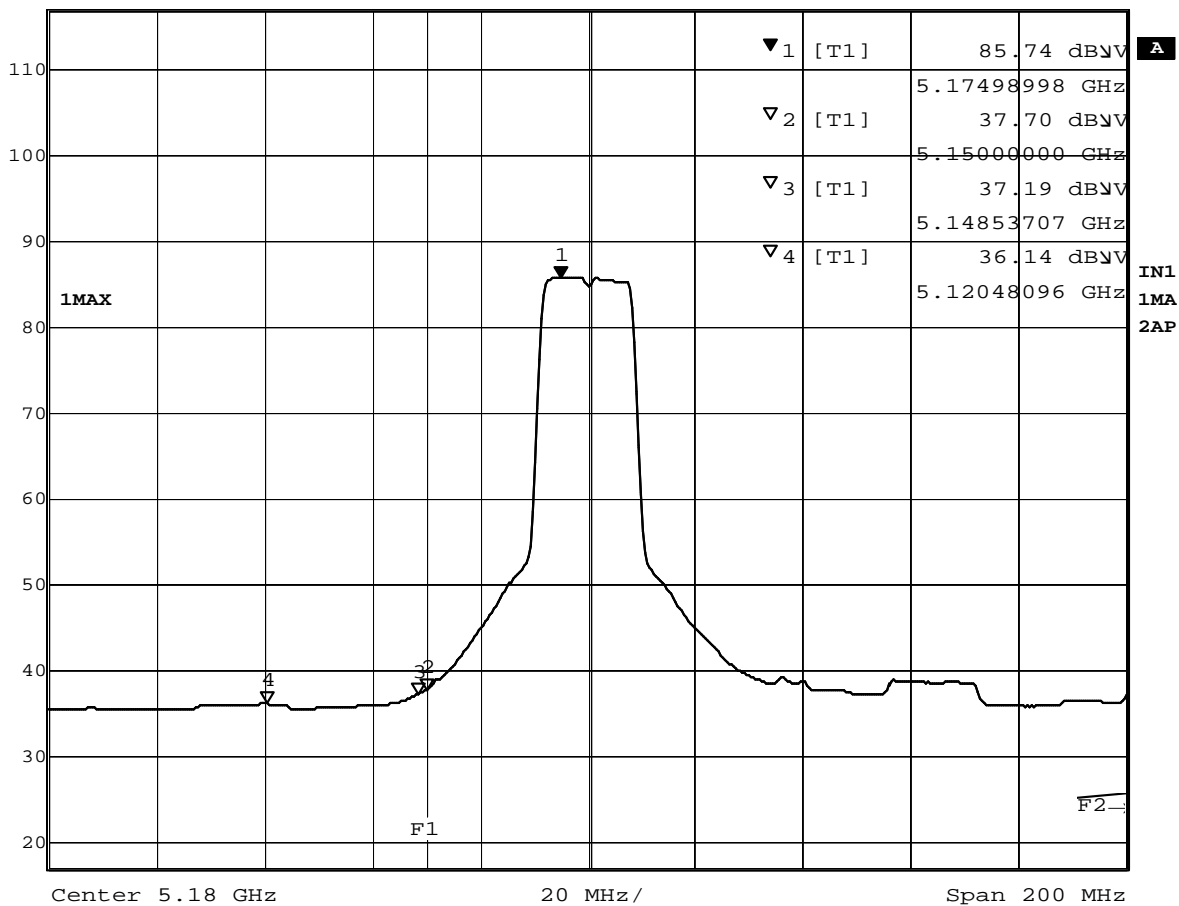

Date: 23.FEB.2004 18:52:07

Plot 7-1-2 5180MHz TX mode (Average)



Marker 1 [T1] RBW 1 MHz RF Att 20 dB
 Ref Lvl 100.34 dBμV VBW 1 MHz
 117 dBμV 5.26150301 GHz SWT 5 ms Unit dBμV

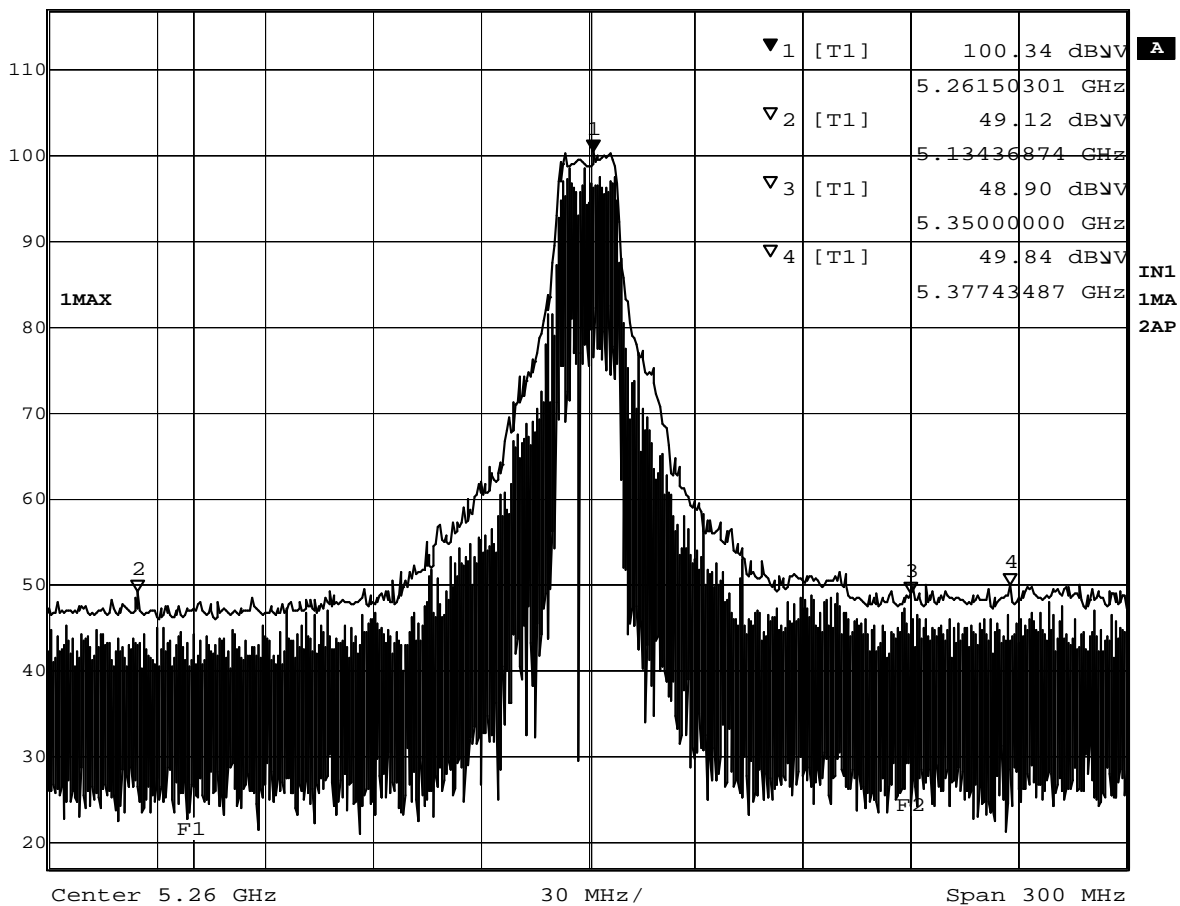

Date: 23.FEB.2004 18:47:11

Plot 7-2-1 5260MHz TX mode (Peak)



Marker 1 [T1] RBW 1 MHz RF Att 20 dB
 Ref Lvl 89.01 dBμV VBW 10 Hz
 117 dBμV 5.26631263 GHz SWT 76 s Unit dBμV

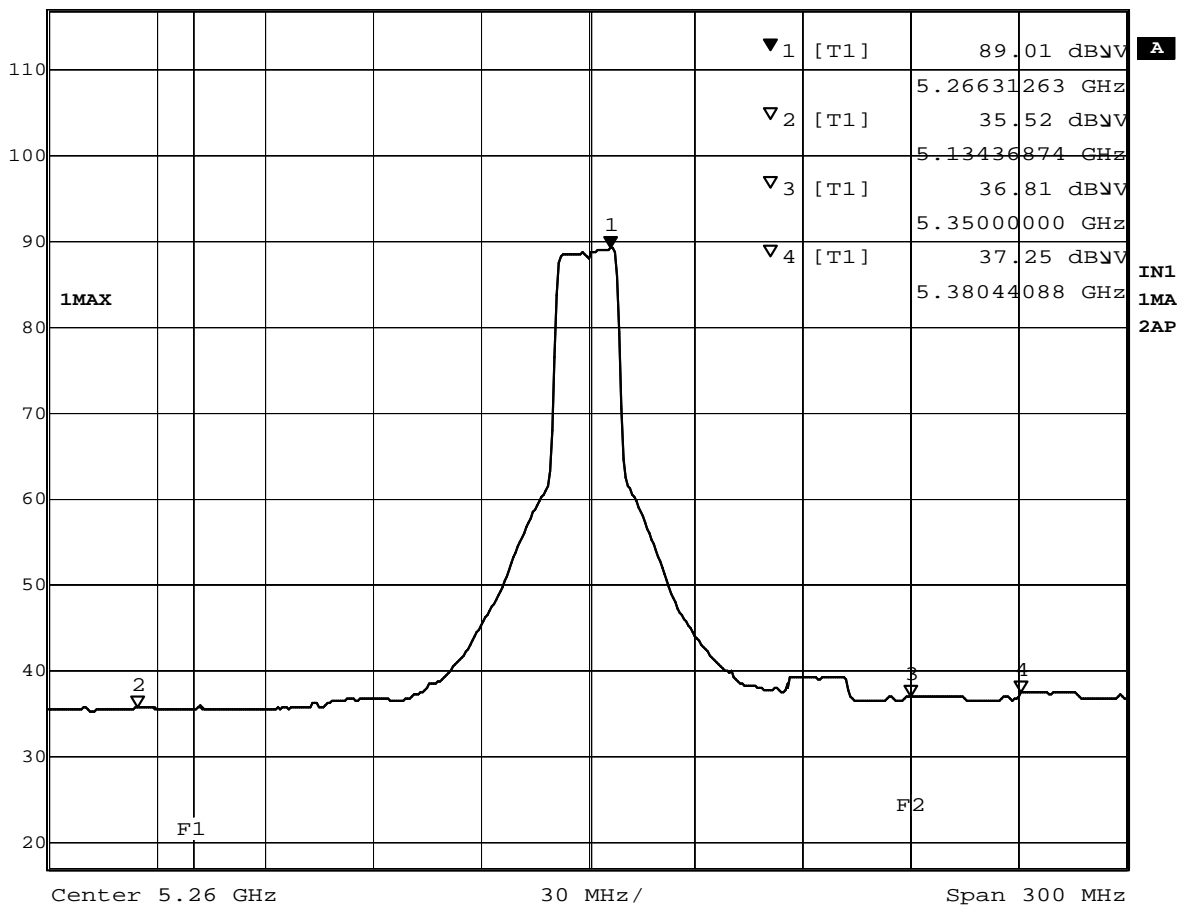

Date: 23.FEB.2004 18:49:02

Plot 7-2-2 5260MHz TX mode (Average)



Marker 1 [T1] RBW 1 MHz RF Att 20 dB
 Ref Lvl 96.65 dBμV VBW 1 MHz
 117 dBμV 5.32420842 GHz SWT 5 ms Unit dBμV

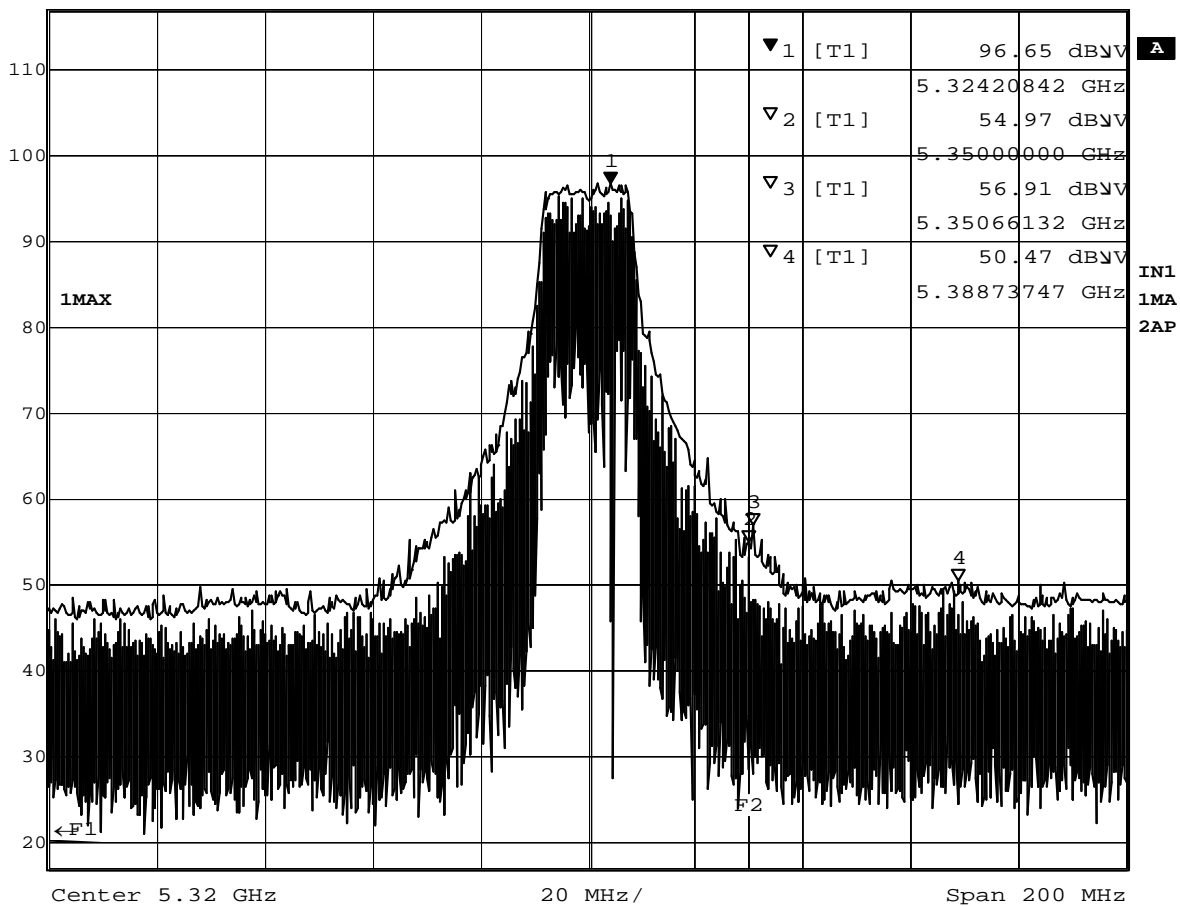

Date: 23.FEB.2004 18:53:49

Plot 7-3-1 5320MHz TX mode (Peak)



Marker 1 [T1] RBW 1 MHz RF Att 20 dB
 Ref Lvl 85.20 dBμV VBW 10 Hz
 117 dBμV 5.32661323 GHz SWT 50 s Unit dBμV

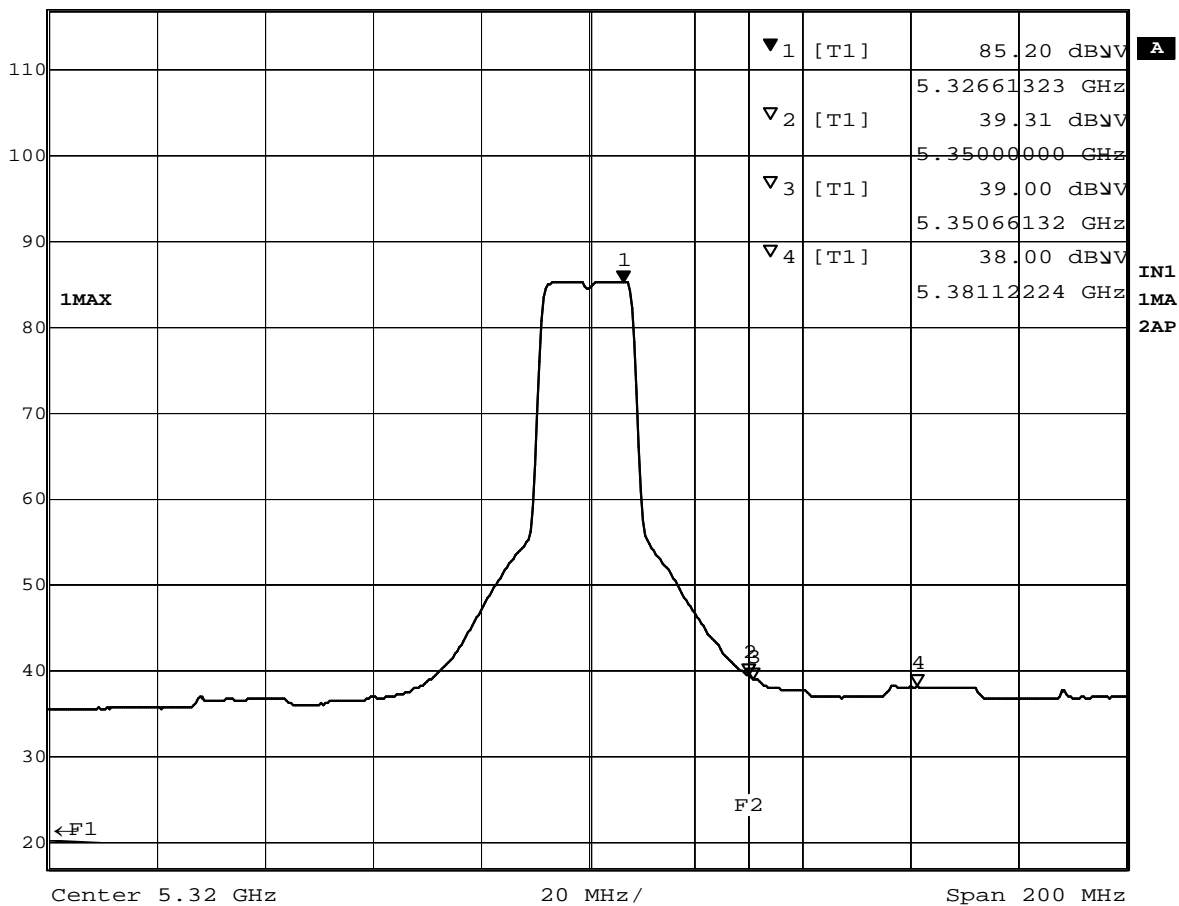

Date: 23.FEB.2004 18:55:08

Plot 7-3-2 5320MHz TX mode (Average)