

# RF Exposure

## 1. RF Exposure evaluation for the applying transmitter

As shown in the following photo, the main antenna, an inverted F-figure type antenna, is built in the top portion of the LCD, and the auxiliary antenna, a coupled floating element antenna, is built in the upper right side of the LCD.

The separation distances between the antennas and the human body are 20cm or more. Therefore the laptop PC can be categorized as a mobile device by FCC CFR 47 Section 2.1091.

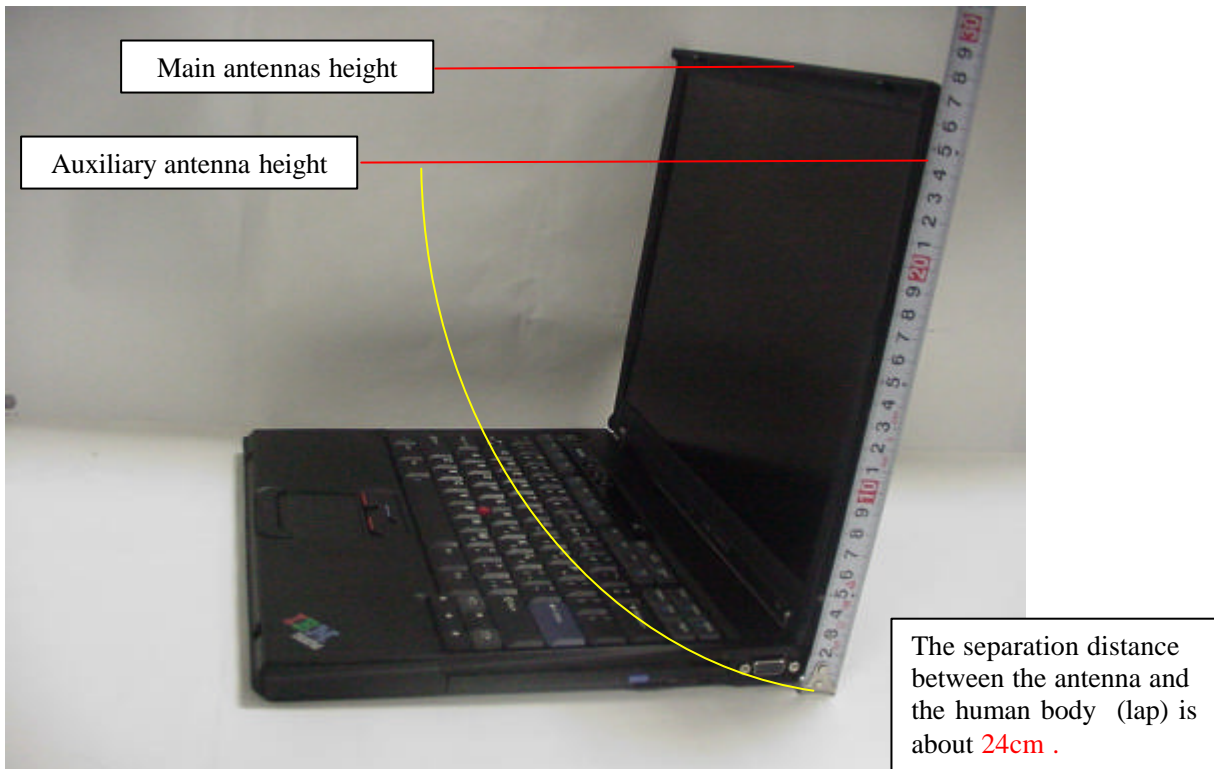

The highest conducted peak output power of the Test Report is 55.0mW (17.4dBm) and the maximum antenna gain is 0.83 dBi (See page 4 of this exhibit.).

Therefore the peak radiated output power(EIRP) is calculated as follows.

$$\text{EIRP} = P + G = 17.4 \text{ dBm} + 0.83 \text{ dBi} = 18.23 \text{ dBm} (66.5 \text{ mW})$$

Then, the maximum power density at 20cm distance is calculated as :

$$S = \text{EIRP} / (4 \times R^2 \times \pi) = 0.132 \text{ mW/cm}^2$$

Since the applying laptop PC's WLAN transmitter does not function to emit the radio frequency from both diversity antennas simultaneously, the above value is the maximum RF exposure to the persons and is below the MPE limit (1.0 mW/ cm<sup>2</sup> ). Therefore the laptop PC meets the MPE requirements for general Population/Uncontrolled exposure.

## 2. RF Exposure evaluation for Bluetooth transmitters

The applying laptop PC (ThinkPad T40 Series) supports three kinds of Bluetooth devices as follows.

	FCC ID	Grantee Name	Product Name	Granted Date	ERP in FCC Test Report
User's option	PI4BT-ULTRA	TDK Systems Europe Ltd.	Bluetooth Ultraport Module	May/22/2001	1.4 mW
	PI4BT-IBM-PCII		Bluetooth PC Card II	August/21/2001	1.0mW
Built-in type LMA Transmitter	ANO20020100MTN	IBM Japan, Ltd.	IBM integrated Bluetooth with 56K Modem	Under inspection with this application	2.5mW

Interfaces to connect Wireless options

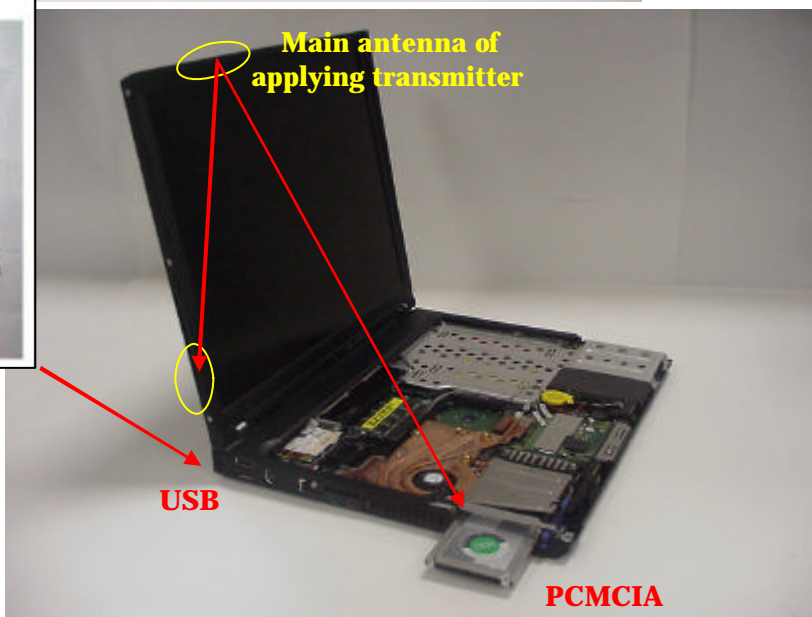
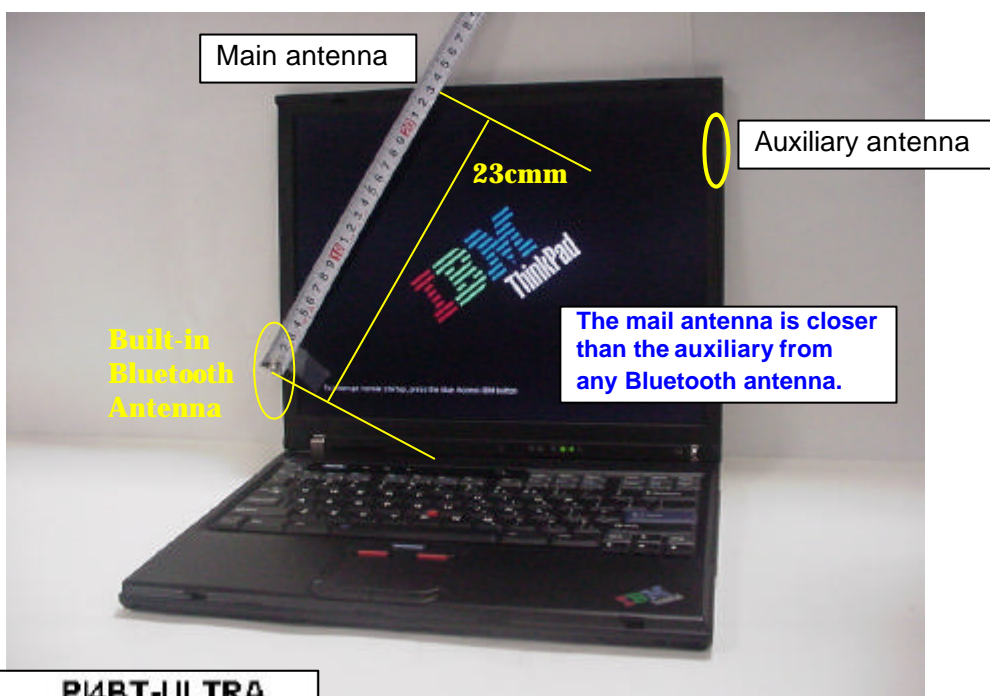

The main and auxiliary antennas of the applying transmitter in the LCD section are assembled apart from each Bluetooth antenna shown in the previous page with 20 cm or more distance.

Therefore the RF exposure evaluation for those Bluetooth transmitters is able to be done independently of the applying antennas. In other word, a collocated SAR testing is not required.

When a customer operates the applying PC on one's lap, the sufficient separation distance (minimum 20cm) between the above Bluetooth antennas and the person's body (lap) can not be maintained.

But the footnote of the Section 3 in Supplement C to OET Bulletin 65 states <sup>14</sup> ..... If a device, its antenna or other radiating structures are operating at closer than 2.5 cm from a person's body or in contact with the body, SAR evaluation may be necessary when the output is more than 50 – 100 mW, depending on the device operating configurations and exposure conditions.”

The total output power of the three Bluetooth transmitters in the previous table does not exceed 5mW. Therefore these transmitters also satisfy the RF exposure evaluation regarding CFR 47 Part 15.247(b)(4) without a SAR compliance test report, and can operate with the applying transmitter simultaneously.

IBM Web site guides to customers about the **grant condition** related to those collaborating transmitter devices. See page 6 of this exhibit.

### 3. Antenna Gains of applying equipment

#### 3.1 Antenna Specification

Transmission Antenna assembly overview

Designator	Manufacture	Antenna type	Cable type and length	Gain (dBi) Note 1)
<b>62P4204</b> Main antenna	<b>Faxconn Electronics Inc. (R.O.C.)</b>	<b>Dual Band Inverted F type Antenna</b>	<b>Coax 745 mm</b>	<b>5150-5350MHz 0.83 dBi (peak)</b>
<b>62P4203</b> Auxiliary antenna	<b>Faxconn Electronics Inc. (R.O.C.)</b>	<b>Dual-Band Coupled Floating Element Antenna</b>	<b>coax 860 mm</b>	<b>5150-5350MHz 0.36 dBi (peak)</b>

Notes:

1a. Includes all cable losses.

1b. Antenna type should be Omni Directional and have gain of 3.0 dBi or less for IEEE802.11a(5GHz band), regarding the IBM internal specification.

#### 3.2 Radiation characteristic of antennas

Radiation characteristic of antenna is measured in regard to the rotation angle  $x^\circ$  as shown below.

**Main Antenna**

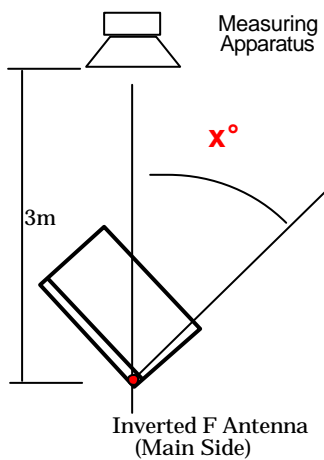

**Auxiliary Antenna**

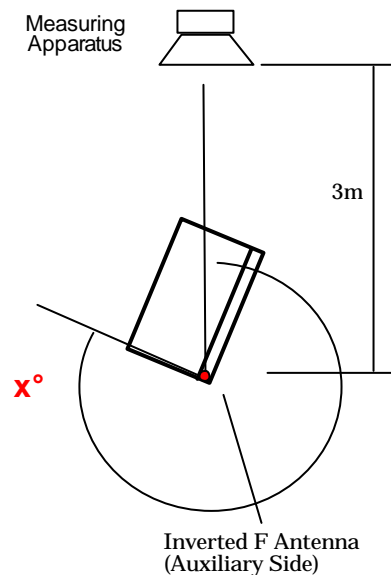

### Main antenna

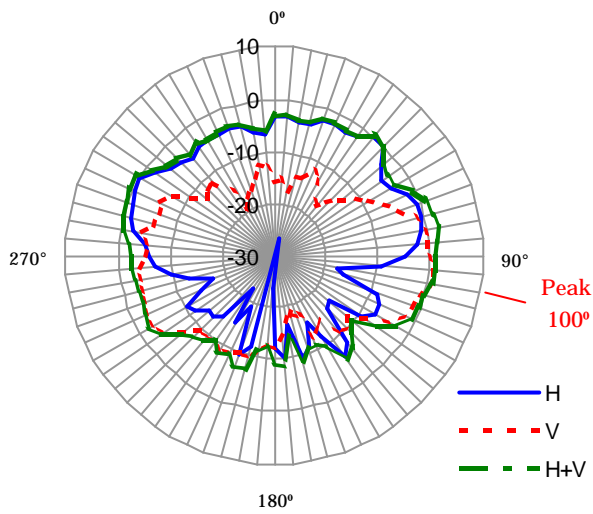

Hori (dBi) ave.	-5.16
Vert (dBi) ave.	-6.38
H+V (dBi) ave.	-2.72
Peak(dBi) ( H )	0.83
Peak Angle ( X°= )	100°
Center Frequency	5350MHz

Note1) The measurement was performed at 3 frequencies (5150, 5250, 5350MHz).

Note2) The maximum antenna gain was found around **100 degree** angle from measuring apparatus in **vertical** polarization at the high frequency (5350MHz).

### Auxiliary antenna

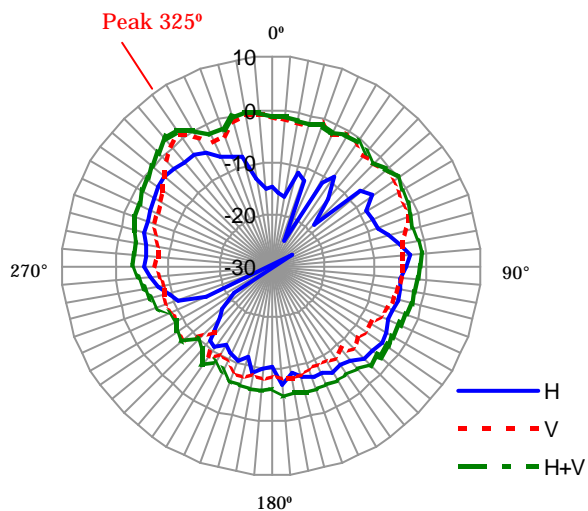

Hori (dBi) ave.	-7.17
Vert (dBi) ave.	-4.43
H+V (dBi) ave.	-2.58
Peak(dBi) ( V )	0.36
Peak Angle ( X°= )	325°
Center Frequency	5250MHz

Note1) The measurement was performed at 3 frequencies (5150, 5250, 5350MHz).

Note2) The maximum antenna gain was found around **325 degree** angle from measuring apparatus in **vertical** polarization at the middle frequency (5250MHz).

## 4. IBM Web site for user’s guidance concerning the co-located transmitters

Note) The contents will be available after the product announcement.

<http://www.pc.ibm.com/qtechinfo/MIGR-44156.html>

The screenshot shows the IBM website interface. At the top, there is a search bar and navigation links for Home, Products & services, Support & downloads, and My account. Below this is a secondary navigation bar with links for PC support home, Login, Profile, My page, Ask an expert, and Help. The main content area is titled "TP Wireless Systems – Additional RF Option devices receive FCC certification". It includes a section for "Applicable countries/regions" (United States) and "Service hints & tips". A table titled "Affected configurations" lists models and their FCC IDs, along with a grid for PC options allowed multiple transmission. Below the table is a "Solution" section with instructions and a numbered list of steps. The footer contains "About IBM", "Privacy", "Legal", and "Contact" links, along with document ID and copyright information.

**TP Wireless Systems – Additional RF Option devices receive FCC certification**

**Applicable countries/regions**  
United States

**Service hints & tips**

**Affected configurations**  
Additional RF Option devices receive FCC certification for use on:

Pre-installed Models of IBM Dual-Band 11a/b Wi-Fi Wireless Mini PCI Adapter	FCC IDs	PC options allowed multiple transmission		
		#1	#2	#3
ThinkPad R40 Series wireless models	ANO20020300D3L	○	○	○
ThinkPad T40 Series wireless models	ANO20020302R1L	○	○	○
ThinkPad X30 Series wireless models (X31, X32)	ANO20020304T2L	○	○	○

[Other wireless pre-installed type or wireless upgradable models](#)

**NG:** Not authorized to use by the FCC rule, nor recognized by BIOS.

FCC ID:                      Option card name

#1: ANO20020100MTN      [IBM Integrated Bluetooth with 56K Modem](#)

#2: PI4BT-ULTRA            [Bluetooth UltraPort Module from IBM](#)

#3: PI4BT-IBM-PCII        [Bluetooth PC Card II](#)

**Solution**  
The supplementary document of ThinkPad’s “Service and Troubleshooting Guide” has the following information in “Wireless regulatory information – USA Federal Communications Commission (FCC)” section:

Please make sure of the following when you use a Bluetooth option or wireless option PC Card in your ThinkPad computer.

1. Visit the IBM site at [www.ibm.com/pc/qtechinfo/MIGR-44156.html](http://www.ibm.com/pc/qtechinfo/MIGR-44156.html) and confirm the updated list of RF option devices that have been approved to cooperate with the integrated wireless feature.
2. When you use any other RF option device that is not listed on the IBM site, all other wireless features including the integrated transmitter in your ThinkPad computer are required to be turned off.
3. Users are requested to follow the RF Safety instructions on wireless option devices that are included in the RF option device’s user’s manual.

Document id: MIGR-44156  
Last modified: 2002-06-03  
Copyright (C) 2002 IBM Corporation