

# Uniden®

**UM725GBT**  
**UM725G**  
**UM725**

VHF MARINE RADIO

RADIO VHF MARITIME



## OWNER'S MANUAL GUIDE D'UTILISATION

This User's Guide provides usage instruction for all models listed above.

Ce Guide de l'utilisateur fournit des instructions d'utilisation pour tous les modèles listés ci-dessus.

## MAKING A DISTRESS CALL

Lift the red cover. Press and hold the **DISTRESS** key for three seconds. Your radio transmits your ship's location every few minutes until you receive a response.

**NOTE:** If the radio displays *Enter User MMSI*, cancel the automatic distress call and make a normal voice distress call.



Lift the red cover and press the **DISTRESS** button underneath

### Making a Voice Distress Call

**Speak slowly - clearly - calmly.**

For future reference, write your ship's name & call sign here:

1. Make sure your radio is on.
2. Press the **16/P** key to switch to Channel 16 (156.8 MHz). (If the corner of the display does not show 16, press the **16/P** key again until it does.)
3. Press the **PUSH-TO-TALK** key and say: "**MAYDAY -- MAYDAY -- MAYDAY.**"
4. Say "**THIS IS {name of your ship (three times)}** and call sign/ship registration number (once)."
5. Repeat "**MAYDAY {name of your ship}**" once.
6. Tell where you are: (what navigational aids or landmarks are near, or read the latitude and longitude from your GPS).
7. State the nature of your distress (e.g. are you sinking, medical emergency, man overboard, on fire, adrift, etc. ).
8. State the type of assistance you need (medical, towing, pumps, etc.).
9. Give number of persons aboard and conditions of any injured persons.
10. Estimate present seaworthiness of your ship (e.g. how immediate is the danger due to flooding or fire or proximity to shore).
11. Briefly describe your ship, giving ship name (e.g. "Blue Duck is 32 foot cabin cruiser, white hull, blue deck house").
12. Say: "**I WILL BE LISTENING ON CHANNEL 16.**"
13. End message by saying "**THIS IS {name or call sign of your ship}, OVER.**"
14. Release the **PUSH-TO-TALK** key and listen.

*If you do not get an answer after 30 seconds, repeat your call, beginning at step 3, above.*

## FAIRE UN APPEL DE DÉTRESSE

Soulevez le couvercle noir. Maintenez **DISTRESS** enfoncé pendant trois secondes. Votre radio transmettra l'emplacement de votre bateau toutes les quelques minutes jusqu'à ce que vous receviez une réponse.



Soulevez le couvercle et appuyez sur le bouton **DISTRESS** en dessous

*Remarque : Si la radio affiche Enter User MMSI, annulez l'appel de détresse automatique et effectuez un appel de détresse vocal normal.*

### Faire un appel de détresse

Parlez lentement – clairement – calmement.

Pour toute référence ultérieure, écrivez ci-dessous le nom et l'indicatif d'appel de votre bateau:

1. Vérifiez si votre radio est en marche.
2. Appuyez sur la touche **16/P** afin de commuter au canal 16 (156,8 MHz). (Si le canal 16 n'apparaît pas à l'affichage, appuyez de nouveau sur la touche **16/P** jusqu'à ce qu'il soit affiché.)
3. Appuyez sur le bouton **Push-to-Talk** et dites: "**MAYDAY -- MAYDAY -- MAYDAY**".
4. Donnez l'identité de votre navire en disant : "**ICI {nom de votre bateau (trois fois) ou indicatif d'appel et le numéro d'identification de votre bateau (une fois)}**".
5. Dites "**MAYDAY {nom ou indicatif d'appel de votre bateau} une fois**".
6. Donnez votre position : (quels sont les points de repère ou aides à la navigation près de vous ou lisez les coordonnées de longitude et de latitude apparaissant sur votre dispositif GPS).
7. Révélez la nature de votre détresse (par exemple, nous sommes en train de couler, urgence médicale, un homme à la mer, un incendie, nous sommes à la dérive, etc.
8. Révélez la nature de l'aide désirée (médicale, remorquage, essence, etc.)
9. Donnez le nombre de personnes à bord et les conditions des blessés, s'il y en a.
10. Donnez la condition de navigabilité actuelle de votre navire, tel que le degré de l'urgence par rapport une inondation, et une incendie.
11. Donnez une brève description de votre navire en donnant le nom du bateau (par exemple, "Blue Duck est un yacht de croisière de 32 pieds, avec une coque blanche et un rouffe bleu.)
12. Dites : "**JE VAIS ÉCOUTER SUR LE CANAL 16**".
13. Terminez le message en disant "**ICI {nom ou indicatif d'appel de votre bateau}, À VOUS**".
14. Relâchez le bouton **Push-to-Talk** du microphone et écoutez.

*Si vous n'obtenez pas de réponse après 30 secondes, répétez l'appel en commençant à l'étape 3 ci-dessus.*

# Table of Contents

What's Included.....	E-2
<b>INSTALLATION .....</b>	<b>E-3</b>
Mounting the radio .....	E-3
Connecting the radio.....	E-5
<b>YOUR UM725 VHF MARITIME RADIO .....</b>	<b>E-6</b>
<b>MMSI NUMBERS .....</b>	<b>E-7</b>
Reading the Radio Screen .....	E-8
Menus .....	E-10
<b>SETTING UP YOUR RADIO .....</b>	<b>E-14</b>
General Setup .....	E-14
Radio Setup .....	E-15
<b>OPERATING THE RADIO .....</b>	<b>E-16</b>
Monitoring a Channel (Normal Mode).....	E-16
Setting the Squelch Level.....	E-16
Scanning Radio Channels .....	E-17
Monitoring Weather Channels .....	E-17
Priority and Weather Alert Watch .....	E-18
Priority Watch.....	E-18
Weather Alert Watch .....	E-19
<b>DIGITAL SELECTIVE CALLING (DSC) .....</b>	<b>E-20</b>
What Is DSC? .....	E-20
How Does DSC Work? .....	E-20
Managing DSC Settings.....	E-21
Setting up DSC Individuals and Groups.....	E-22
DSC Calls.....	E-24
DSC Call Logs.....	E-27
Making a Transmission .....	E-28
Position requests.....	E-29
Making an Automatic Distress Call.....	E-33
MOB Soft Key .....	E-33
<b>GPS FEATURES.....</b>	<b>E-34</b>
Waypoints and Routes .....	E-35
<b>CHARTPLOTTER CONNECTION .....</b>	<b>E-37</b>
Chartplotter Settings .....	E-37
<b>MAINTENANCE AND TROUBLESHOOTING.....</b>	<b>E-39</b>

---

<b>SPECIFICATIONS</b> .....	<b>E-40</b>
<b>REFERENCE TABLES</b> .....	<b>E-41</b>
Marine Radio Channel Chart.....	E-41
Canadian Frequency Chart.....	E-43
International Frequency Chart .....	E-45
Weather Channels And Frequencies (Us, Can, And Intl).....	E-47
NMEA2000 PGN LIST (UM725GBT ONLY).....	E-48
Emergency Alert (SAME) System Event Types .....	E-50
Response Event Code .....	E-51
<b>REGULATIONS AND SAFETY WARNINGS</b> .....	<b>E-52</b>
Maritime Radio Services Operation .....	E-52
Basic Radio Guidelines .....	E-52
Compliance .....	E-53
<b>THREE-YEAR LIMITED WARRANTY</b> .....	<b>E-55</b>

---

# UNIDEN® VHF MARINE RADIO (UM725)

- **UM725GBT:** VHF Marine Radio with GPS and Bluetooth – Class D DSC radio with integrated GPS and Bluetooth, so you can use Uniden's smartphone app (iOS and Android) to set up the radio and text message other VHF text message capable radios.
- **UM725G:** VHF Marine Radio with GPS – Class D DSC radio with integrated GPS receiver.
- **UM725:** VHF Marine Radio – Class D DSC radio

Your radio provides the following key features:

- **DSC.** Provides communication to other ships or groups using their unique identification code. This radio includes a second **Class D Receiver** to Monitor only DSC watch channel 70 (dedicated) to ensure that no incoming messages are missed.
- **GPS (Favorite Position mode).** Saves your current position or lets you manually enter other positions. Provides a directory to save positions for return as desired. Provides a list of saved waypoints and routes that you can save and use to navigate.
- **NMEA input/output.** Provides connection to a chartplotter and, through menus, determine what NMEA data you want to receive.
- **Compass Display.** Programmable to display your course - by showing your course and direction or by showing location on an north-south-east-west display. Automatically auto-plots to a received DSC distress call.
- **MOB (Man Overboard).** Locks onto the current position in Man Overboard situations.
- **National Oceanic and Atmospheric Administration (NOAA) Weather Channel watch.** Sounds a warning tone when a hazard alert is issued. It also has 10 weather channels available for monitoring.
- **Memory Scan.** Monitors saved channels in quick succession. All marine VHF channels for the U.S., Canada, and international waters
- **Dual- Triple-Watch.** Monitors Coast Guard distress, hailing, or priority channels and one weather channel along with one regular marine channel.
- **Emergency Channel (16) Monitoring.** Scans this emergency channel regularly within normal scanning cycles.

## WHAT'S INCLUDED



**NOTE:** Some of the images in this manual may vary slightly from the actual product. If any pieces are missing or damaged, contact Customer Service at [www.uniden.com](http://www.uniden.com).

# INSTALLATION

## MOUNTING THE RADIO

The included mounting bracket allows your radio to sit at any angle to accommodate the best location. Select a location that can:

- Properly support the weight of the radio. You may need some type of anchor with mounting screws, depending on the surface.
- Keep the battery leads as short as possible.
- Keep the antenna lead-in wire as short as possible.
- Allow free air flow around the heat sink on the rear of the radio.
- Avoid interference with the ship's compass.

---

**Note:** To extend the life of the radio, use waterproofer's instructions.

---

### TO INSTALL THE MOUNTING BRACKET:

1. Slide the radio into the mounting bracket and tighten the mounting knobs to secure the radio in place.
2. Position the radio into the desired location and mark the edges of the bracket on the mounting surface.
3. Remove the **mounting bracket drill template** from the back of the manual, and use the template to mark the drill holes on the mounting surface.
4. Drill the holes for the mounting bracket; be sure to follow any special requirements of the mounting surface.
5. Remove the bracket from the radio and use the mounting hardware to secure the bracket to the mounting surface.
6. Install the radio back into the mounting bracket.

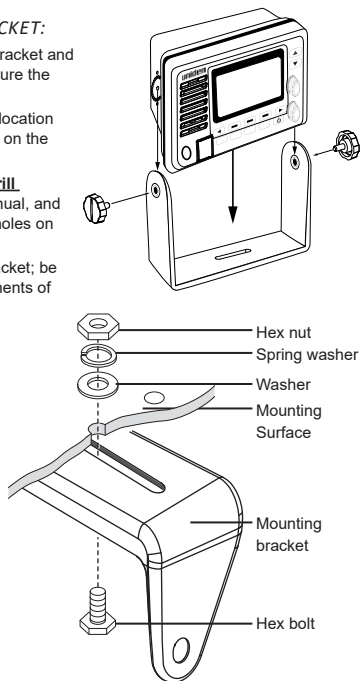

### TO INSTALL THE FLUSH-MOUNT BRACKET:

You will need an opening for that radio that measures 5.5" by 2.85" to fit into (large enough for the back of the radio to fit, but for the face of the radio to sit flush on the surface). You will need clearance of at least 3.5" behind the radio to accommodate all the necessary connections.

---

**Tip:** If you are cutting the opening in the surface, carefully examine the entire area before you begin, including clearance behind the surface. Make sure all connections can reach the radio. If you are uncertain of your placement, consult a professional.

---

1. Slide the radio into the surface opening.
2. Align the mounting brackets with the screw holes on the radio as indicated.
3. Insert and tighten the screws to secure the radio in place. The pads of the mounting brackets should press firmly against the interior of the mounting surface.

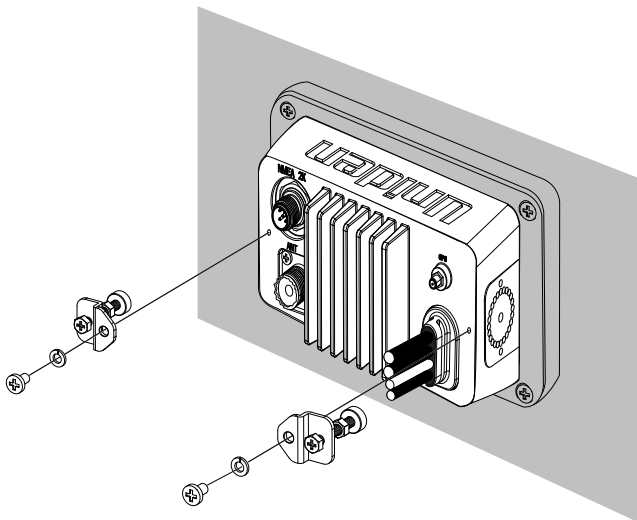



## CONNECTING THE RADIO

To operate correctly, your radio requires a power source and an antenna. Additionally, you can connect your radio to an external GPS antenna, chartplotter, and/or a remote microphone.

Power Supply Requirements	VHF Antenna Requirements
Nominal 13.8 VDC power supply with a negative ground (10.5 VDC to 16.0 VDC). Short power leads directly connected to the power supply is ideal. Copper wire extensions (minimums): <ul style="list-style-type: none"><li>◆ Up to 20 ft. – 14 AWG</li><li>◆ 20-35 ft. – 12 AWG</li><li>◆ 35-60 ft. – 10 AWG</li></ul>	PL-259 connector 50 $\Omega$ impedance Antenna rating (minimum): <ul style="list-style-type: none"><li>◆ Powerboats – 4 ft., 3 dB</li><li>◆ Sailboats or 8 foot – 6dB</li></ul> Minimum lead-in wire: <ul style="list-style-type: none"><li>◆ Up to 20 ft. – RG-58</li><li>◆ 20-35 ft. – RG-8X</li><li>◆ 35-60 ft. – RG-8U</li></ul>

### TO CONNECT YOUR RADIO:

1. Connect your boat's power supply using the black and red power connector.
2. Connect your radio antenna's PL-259 connector to the radio's antenna port, labeled **ANT**.
3. You can connect your radio to your boat's navigation system using one of the following connectors:
  - **GPS/Ext SP**
  - **GPS** (UM725G/UM725GBT Only)
  - **NMEA 2K** (UM725GBT Only).

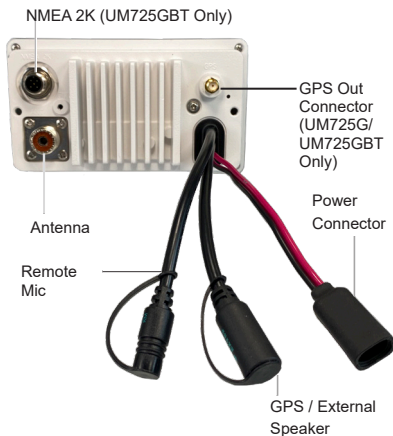

## YOUR UM725 VHF MARITIME RADIO

Your UM725 VHF Maritime Radio is designed to provide quick and easy access to critical functions and cool features. For most operation, the UM725 uses a 3-part operating structure: Physical Controls, Menus, and Soft Keys.

- Physical Controls – Use the radio's buttons and knobs to access and navigate various menu settings and functions.
- Menus – Press the **MENU** button to access and various menu settings and functions.
- Soft Keys – Use the dynamic Soft Key and scroll buttons to access features and make selections based on the current screen.



CH ▲ / ▼ – Cycle up and down through channels, and can be used to navigate menu options.

VOL – Volume

PUSH/SEL – Turn and press to highlight and select menu options, and to set Squelch settings.

POWER – Turns your radio on and off.

16/P – Cycles through call channel, channels 16 and a priority channel, and back to the starting channel.

CLEAR – Returns to the main screen.

MENU – Accesses the radio menus.

H/L – change the transmission power from 1W to 25W (If the maximum output for a channel is 1W only, the output power stays to 1W.)

Soft Keys – Activates assigned functions based on the screen above.

DISTRESS – Sends out default distress signal.

Push to Talk

Cycle up and down through channels

Cycles through call channel, channels 16 and Priority



## MMSI NUMBERS

When you power up your radio for the first time, *MMSI Not Entered* appears, followed by a Marine mode screen. In order to use DSC features, you must be assigned an individual User MMSI number and program that number into your radio. User MMSI numbers are unique and cannot be entered more than once.

**If you choose to not enter your specific MMSI number at initial start up, you can still use many of your radio's features. However, some radio functions will be impacted, and you will not be able to use any DSC features.**

You can get more information on MMSI numbers at these resources:

- The dealer where you purchased the radio
- Recreational boaters can obtain an individual MMSI number from the Boat Owner's Association of the U.S. (<http://www.boatus.com/mmsi/> or call 800-563-1536) or Sea Tow Services International ([http://seatow.com/boating\\_safety/mmsi.asp](http://seatow.com/boating_safety/mmsi.asp))
- Commercial boaters need a ship station license to get an MMSI number. For more information, visit the Federal Communications Commission (FCC) website at <http://wireless.fcc.gov/marine/fctsht14.html>.

---

**Tip:** Before you begin this process, have your MMSI number available and familiarize yourself with the menu navigation on Page E-10. **Be sure you have the correct User MMSI number before entering it in the radio. The radio only allows you to enter the User MMSI once.** If you need to re-enter the User MMSI number, visit <http://support.uniden.com/marine-radios/> for assistance.

---

### TO ENTER YOUR MMSI NUMBER:

1. Press and hold the  button until the unit turns on. An **ATTENTION** message appears.
2. Press **PROG**. The ENTER MMSI screen appears.
3. Use the **PUSH/SELECT** knob to enter each digit of your MMSI number.
4. Press the **SAVE** Soft Key to save the MMSI number.

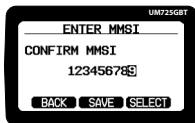
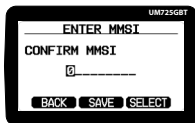

## READING THE RADIO SCREEN

Your radio screen shows a different combination of icons and information depending on the current operation, each designed to provide information intuitively.

**Note:** Your UM725 VHF Radio is designed to be dynamic and flexible to provide many features. Therefore screens can vary greatly depending on your unique settings. The screen below shows some commonly used screens that you may encounter.

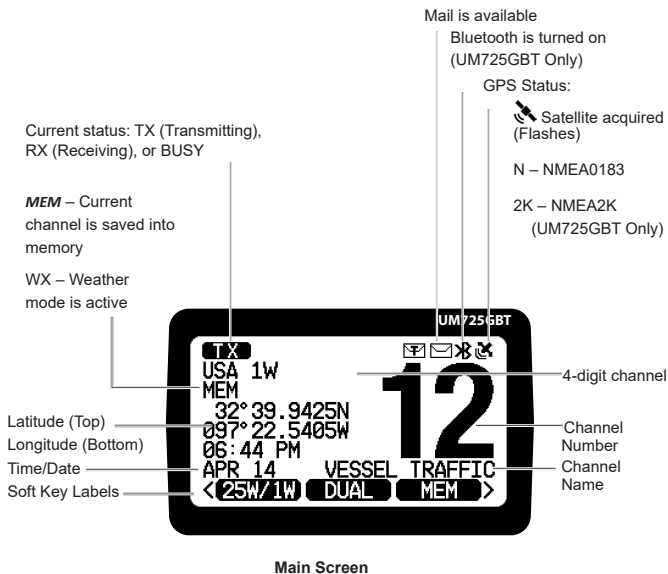

## Menu Screens

Various menus let you access various radio settings and functions. You can navigate these menus using a combination of controls, such as the **PUSH/SELECT** knob, **CH ▲ ▼** buttons, or dynamic soft key options that appear.

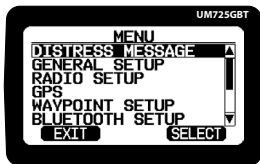

## Keyboard Screens

Keyboard screens appear when a setting requires a text entry. Use the **PUSH/SELECT** knob, **CH ▲ ▼** buttons, and dynamic soft key options that appear with the keyboards to enter text.



## Compass Screen

The compass screen appears when you press the **COMP** soft key. Its appearance may vary depending on your unique radio settings.

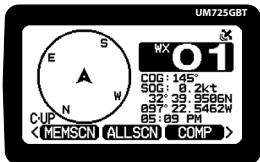

## MENUS

Various menus let you access settings for your radio, and various functions of your radio. You can navigate these menus using a combination of controls.

Press the **MENU** button to access the radio's main menu. Turn the **PUSH/SELECT** knob to select a menu item, then press the knob to open that menu.

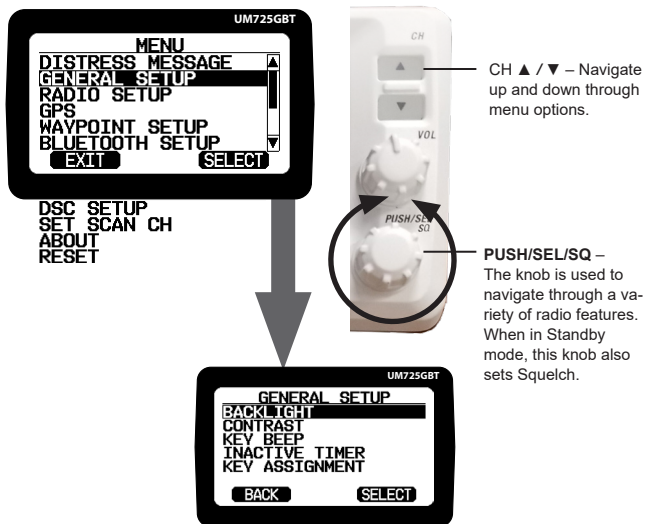

---

**Tip:** Your UM725 VHF Radio is designed to provide flexibility in its controls. You can navigate menus using several methods: the the **PUSH/SELECT** knob, **CH ▲ ▼** buttons, and dynamic soft key options that appear. Familiarize yourself with how various navigation options work to find what works best for you. This will make navigation easier.

---

Main Menu	Description
DISTRESS MESSAGE	Opens a Submenu to select a distress messages type to transmit when you press the radio DISTRESS button. For more information regarding distress calls, see <b>"Making a Voice Distress Call" on page ii.</b>
GENERAL SETUP	Accesses basic configuration of general preferences, such as how the backlight and key beep function. For more information regarding general setup, see <b>"General Setup" on page E-14.</b>
RADIO SETUP	Accesses settings for radio functions, such as priority and weather alert watches. For more information regarding radio setup, see <b>"Radio Setup" on page E-15.</b>
GPS	Your GPS system provides more than just your specific location. You can determine power-saving options, measurement increments, and time settings. For more information regarding GPS functions, see <b>"GPS FEATURES" on page E-34.</b>
WAYPOINT SETUP	Waypoints (landmarks) mark specific points between two locations. They serve as directional indicators. For more information regarding waypoints, see <b>"Waypoints and Routes" on page E-35.</b>
BLUETOOTH SETUP	Accesses basic configuration of Bluetooth functions (UM725GBT models only). For more information regarding waypoints, see <b>"Setting Up Bluetooth (UM7250GBT Only)" on page E-15.</b>
DSC SETUP	Accesses settings for Digital Selective Calling functions, such as setting up contacts for ship-to-ship and group communications. For more information regarding DSC setup, see <b>"Managing DSC Settings" on page E-21.</b>
SET SCAN CH	Lets you turn scanning on or off for specific channels. For more information regarding DSC setup, see <b>"Scanning Radio Channels" on page E-17.</b>
ABOUT	Displays radio software versions.
RESET	Resets factory defaults, except for the MMSI number.

## Soft Keys

Soft keys offer quick access to many radio functions, using only the three buttons immediately beneath the screen and the two scroll buttons.

**Note:** Some Soft Key functions may change appearance and operation based on radio settings. See "SETTING UP YOUR RADIO" on page E-14.

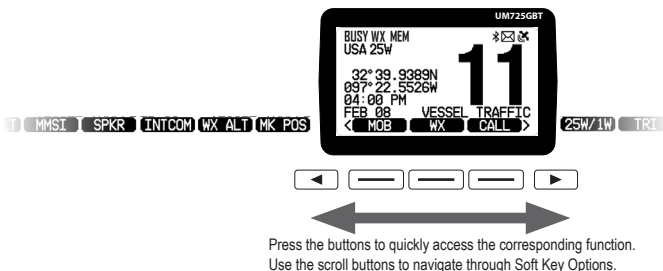

Soft Key	Description
<b>MOB</b>	(Man Over Board) – The GPS automatically marks your current location as MOB and displays the latitude, longitude, time, BRG (Bearing to Destination), and DIST (Distance to Destination).
<b>WX</b>	Displays the last weather channel accessed, latitude, longitude, and time. Turn the <b>PRESS/SELECT</b> knob to scroll through weather channels and press the knob to select that channel.
<b>CALL</b>	Use as a shortcut to making various calls. You can also send and receive position requests and view the DSC call logs.
<b>25W/1W</b>	Changes the transmission power from 1W to 25W. The transmission power icon displays.  (If the maximum output for a specific channel is 1W only, the output power stays to 1W and the radio sounds an error tone.)
<b>DUAL</b> <b>TRI</b>	Depending on your radio setup, this soft key displays TRI or DUAL.  If TRI, the radio scans the current channel, channel 16, and the priority channel. If DUAL, the radio scans the current channel and channel 16.



Soft Key	Description
<b>MEM</b>	Saves the current channel into memory. If the channel is already saved into memory, selecting this key will remove it from memory.
<b>MEMSCN</b>	Scans channels saved into memory.
<b>ALLSCN</b>	Scans all available channels.
<b>COMP</b>	(Compass) – Activates the compass screen. Select the N-UP soft key to orient the radio to north. When in N-UP mode, the soft key changes to C-UP mode, which you can select to orient the compass to the course's next Waypoint, shown by a black dot.
<b>NAVI</b>	Accesses a previously stored route or waypoint as your destination.
<b>WPT</b>	(Waypoints) – Waypoints are location coordinates you've saved into the system. Select waypoints (location coordinates that you've previously saved in your radio) to navigate to.
<b>TXT</b>	Accesses text messages (view, send, and receive) and turn Bluetooth on and off (UM7250GBT Only).
<b>BACKLT</b>	Changes the radio's backlight color between amber and white.
<b>MMSI</b>	Displays your MMSI number for reference.
<b>SPKR</b>	Sounds an alert tone.
<b>INTCOM</b>	Places the radio in intercom mode for hands-free back and forth transmissions.
<b>WX ALT</b>	Activates the radio's Weather Alert Watch.
<b>MK POS</b>	Marks your current position, and gives you the option to name and save the marker.

## SETTING UP YOUR RADIO

Even though you can change your radio's settings at any time, as needed, you will probably want to establish initial settings when you turn it on for the first time. Below are some basic settings that are recommended for initial set up.

### GENERAL SETUP

1. Press the **MENU** button, then turn the **PUSH/SEL** knob to select **GENERAL SETUP**. Press the **PUSH/SEL** knob again, and the GENERAL SETUP submenu appears.
2. From here, you can use the **PUSH/SEL** knob and **▲** or **▼** buttons to access and customize general settings for your radio:
  - **BACKLIGHT:**
    - **BACKLIGHT LEVEL** – brightness, 0 - 8 (0=Off).
    - **BACKLIGHT COLOR** – White or amber.
  - **CONTRAST/RVS** – contrast levels 1 - 20, or invert the colors.
  - **KEY BEEP** – Off or levels 1 - 8.
  - **INACTIVE TIMER** – When inactive for 1, 2, 3, 5, 8, or 10 minutes, the radio returns to the main screen.
  - **KEY ASSIGNMENT** – Lets you reorder the soft key functions.

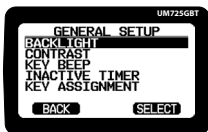
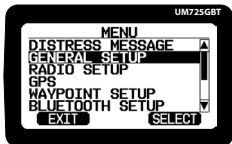

### TO SETUP A REMOTE MIC:

Your radio's supports access via remote mic. The **REMOTE MIC SETUP** menu appears only when a remote mic is connected.

1. Connect the Remote Menu to the Remote Mic Connector, marked **RM**, on your radio.
2. Press **MENU** button on your radio and then use the **PUSH/SEL** knob to access the **REMOTE MIC SETUP** menu.
3. From here, you can use the **PUSH/SEL** knob and **▲** or **▼** buttons to access and customize general settings for your radio:
  - **BACKLIGHT:**
    - **BACKLIGHT LEVEL** – brightness, 0 - 8 (0=Off).
    - **BACKLIGHT COLOR** – White or amber.
  - **CONTRAST/RVS** – contrast levels 1 - 20, or invert the colors.
  - **KEY BEEP** – Off or levels 1 - 8.

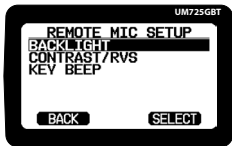
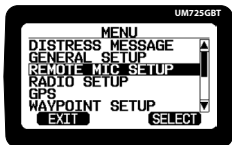

## RADIO SETUP

1. Press the **MENU** button, then turn the **PUSH/SEL** knob to select **RADIO SETUP**. Press the **PUSH/SEL** knob again, and the **RADIO SETUP** submenu appears.
2. From here, you can use the **PUSH/SEL** knob and **▲** or **▼** buttons to access and customize settings used for various radio functions:
  - **CHANNEL MODE** – **USA**, **CAN**, or **INTL**. (For USA, Canada, or International waters.)
  - **WEATHER RADIO** – Activate Weather Alert Watch or enter FIPS Codes.
  - **DUAL/TRI WATCH** – Your radio can scan channel 16 and the priority channel in the background.
  - **PRIORITY CHANNEL** – Select 1 or 2 DSC priority channel(s). (Default = 16).
  - **SCAN PAUSE TIMER** – How long the radio will remain on a received transmission during scanning: 1, 2, 3, 4, 5, 10 seconds.
  - **CHANNEL NAME** – Use to rename channels, if desired.
  - **NOISE CANCEL** – ON/OFF for transmissions and receiving.
  - **RECEIVE AUDIO PITC** – Normal or Mid, High Boost, or Low Boost.

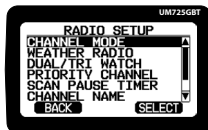
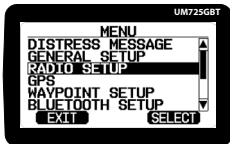

### TO ADJUST YOUR TIME SETTINGS:

Your radio's time display settings are accessed through the **GPS** menu.

1. Press **MENU** button, and then use the **PUSH/SEL** knob to access the **GPS** menu.
2. From this menu, you can use the **PUSH/SEL** knob to access and customize **TIME DISPLAY** settings for your radio.
3. Use the **PUSH/SEL** knob to customize time settings for your radio.
4. To set your local time, select **LOCAL TIME**, then select **LOCAL TIME ADJUST**.
5. (Optional) To use a 24-hour format, select **LOCAL TIME FORMAT** and then select **24-HOUR**.

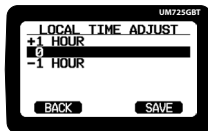
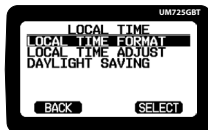
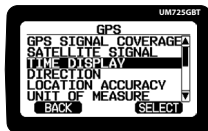

## OPERATING THE RADIO

In order to customize your radio to your specific needs, it is important to understand it's basic operation. Your radio has three main operation modes:

Normal	Scan	Weather
Monitors a single channel and lets you talk on that channel to another radio.	Sequentially checks for transmissions on all channels or channels saved in memory.	Monitors the selected NOAA weather channel. Hear the current or forecasted weather.

### MONITORING A CHANNEL (NORMAL MODE)

To monitor a channel, press either of the **CH** buttons (▲ ▼) to select the desired channel (press and hold to scroll quickly). The radio will remain on that channel and you will be able to hear any transmissions on that channel.

To save the current channel into memory, press the **MEM** soft key; **MEM** appears onscreen for saved channels. (To remove a saved channel from memory, press the **MEM** soft key again.)

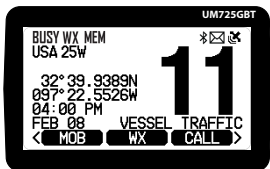

**Tip:** Saving specific channels to memory enables your radio to scan those channels, expanding your ability to listen for transmissions in your area. If you discover that a saved channel has a different common name in your local area, you can change the channel name using the **Radio Setup** menu.

#### Setting the Squelch Level

The UM725 recognizes signals as transmissions if they exceed a signal strength threshold that can be adjusted using the squelch. The squelch feature reduces static on the speaker by filtering out any background channel noise.

Increasing squelch requires a signal to be stronger to be seen as a transmission, filtering out noise and letting only actual radio transmissions through. Set too high, you risk missing transmissions lower than the threshold.

Reducing the squelch allows weaker signals to be accepted, but can result in "white noise."

While in Standby mode, press the **PUSH/VOL/SQ** and turn to adjust the squelch.

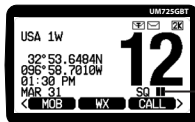
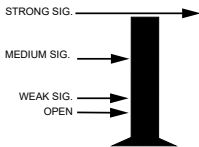

Squelch Setting

## SCANNING RADIO CHANNELS

Scan Mode sequentially checks channels that you have saved in memory. You must have at least two channels saved in memory to start a scan.

To scan saved channels, press the **MEMSCAN** soft key. To scan all channels, press the **ALLSCAN** soft key.

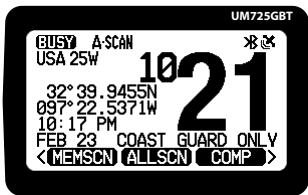

The radio scans channels according to your radio settings, including Priority and Weather Alert watch, if set. If the radio detects a transmission, it stays on that channel; when the signal stops, the radio resumes scanning. When the radio receives a transmission, it pauses the scan and stays on the transmitting channel. Press **▲** or **▼** to leave that channel and resume scanning.

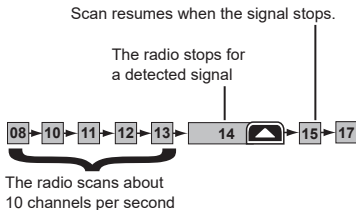

To end the scan, press the **SCAN** soft key. The radio remains on the last scanned channel.

---

**Tip:** If your radio stops on a transmission during ALLSCAN, you may want to save the channel to memory, so that you can easily return to the channel again later or include it when you perform a MEMSCAN.

---

## MONITORING WEATHER CHANNELS

To monitor saved weather channels, press the **WX** soft key. The radio tunes to one of the 10 NOAA weather channels. If a weather alert signal is received in Weather Alert mode, the radio sounds an alert tone. The NOAA weather channels cooperate with the FCC to alert you of other hazards besides weather (child abduction alerts, nuclear, biological, etc.).

- You cannot transmit while in Weather mode.
- To turn off the radio's alert tone, press any key.

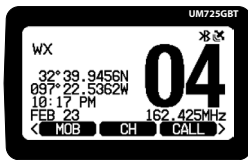

---

**Note:** FIPS codes identify counties in the United States. FIPS codes allow you to receive only the Specific Area Message Encoding (S.A.M.E.) alert occurring in a specific area. You can enter a maximum of 30 FIPS codes. For USA FIPS codes by state, see <http://www.nws.noaa.gov>. For Canadian FIPS codes, see <https://www.ec.gc.ca>.

---

## PRIORITY AND WEATHER ALERT WATCH

In addition to the three operation modes, your radio provides two watch functions that set the radio to quickly and regularly check for activity on specific channels.

- Priority Watch – Checks 1-2 designate Priority channels for activity every two seconds.
- Weather Alert Watch – Checks the weather channel for alerts every seven seconds.

### Priority Watch

Your radio comes with a preprogrammed Priority channel. Your radio will function normally, and will also check the Priority channel(s) every two seconds. If the radio detects a transmission, it will stay on that channel; when the signal stops, the radio resumes scanning. To activate Priority Watch, press the **TRI** (or **DUAL**) soft key.

---

**Note:** Private ships must monitor channel 16 whenever they are underway. Water-going ships should have a Priority Watch on at all times.

---

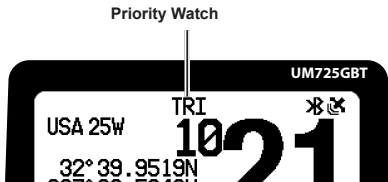

### During Normal Mode

Monitors one channel, checking channel 16 and the Priority channels every 2 seconds.

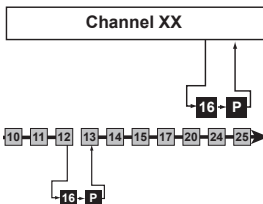

### During Scan Mode

Scans multiple channels, checking channel 16 and the Priority channels every 2 seconds.

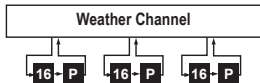

### During Weather Mode

Monitors a weather channel, checking channel 16 and the Priority channels every 2 seconds.

## Weather Alert Watch

When Weather Alert Watch is active, your radio will function normally, and will also check the most recent weather channel every seven seconds. If the radio detects a transmission, it will stay on that channel; when the signal stops, the radio resumes scanning.

To activate Weather Watch, press the **MENU** button, and then use the **PRESS/SEL** knob to access the **RADIO SETUP/WEATHER RADIO** menu. access the **RADIO SETUP** menu and **WEATHER RADIO** submenu.



### During Normal Mode

Monitors one channel, checking weather channel every 7 seconds.

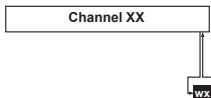

### During Scan Mode

Scans multiple channels, checking weather channel every 7 seconds.

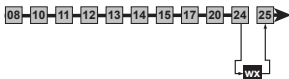

### During Weather Mode

While in Weather mode, the Weather Alert function operates as a type of "sleep mode." The radio stays on the weather channel and mutes the speaker, and if the radio detects an alert, it sounds an alert tone, switch to that weather channel, and turns the speaker back on. This function is useful if you anchor for the night but want to keep informed of hazards.

To activate both Weather Alert Watch and Priority Watch at the same time, activate Weather Alert watch using the **RADIO SETUP/WEATHER RADIO** menu, and then while scanning, press the **DUAL** (or **TRI**) soft key.

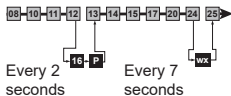

# DIGITAL SELECTIVE CALLING (DSC)

## WHAT IS DSC?

Digital Selective Calling (DSC) is a standard that allows you to quickly and easily call specific radios or groups of radios using their unique MMSI (Maritime Mobile Service Identity) number. The four basic call types are:

- Distress Calls – Use in emergencies only! The Distress message alerts all ships that you need assistance and sends your current position.
- Individual Calls – Calls a single station using the User MMSI. Use when you want to talk to another station
- Group Calls – Calls all ships with the same Group MMSI. Use to talk with your whole group at the same time.
- All Ships Calls – Calls all ships within range of your radio. Should only be used for safety warnings (e.g., debris in the water) or urgent situations.

## HOW DOES DSC WORK?

The DSC standard dedicates a VHF channel—channel 70—to digital transmissions only. Because digital transmissions require less bandwidth than voice transmissions, channel 70 avoids the problems of busy voice channels. The radio uses channel 70 to transmit your MMSI number to the other station along with a voice channel.

If the other station accepts your call, both radios automatically switch to the requested voice channel so you can talk to the other station.

DSC also provides a system for automated distress calls. At the touch of a key, the radio can transmit your MMSI number, the nature of your distress, and your current position based on data from your GPS receiver. The radio repeats the distress call every few minutes until it receives an acknowledgement. Much like familiar "contacts" and "group text" functions of modern phones, your UM725 lets you save individual contacts in your Individual Directory and groups in your Group Directory.

Suppose you are coordinating safety for a sailboat race. Before the race starts, you instruct all the racers to enter your group MMSI number into their radios. During the race:

- Throughout the race, you use group calling to update the racers on the time, race status, and any course corrections.
- A power boat full of spectators comes too close to the race path. You use individual calling to contact the power boat and advise them to stay clear of the race.
- You see a rowboat entering the area, but since it doesn't have a radio, you can't communicate with the rowboat. You use all ships calling to alert all the other ships in the area of the possible danger.

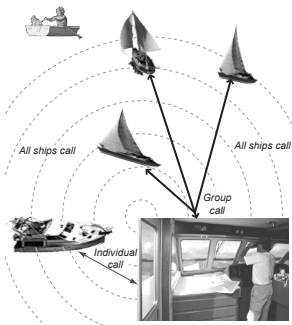



## MANAGING DSC SETTINGS

Even though you can change your DSC settings, as needed, you will probably want to establish initial settings.

1. Press **MENU** button, select the **DSC SETUP** menu and press **SELECT**. The **DSC SETUP** menu appears.
2. From here, you can use the **PUSH/SEL** knob and **▲** or **▼** buttons to access and customize DSC settings for your radio:
  - **RADIO MMSI NUMBER** – Displays your MMSI number.
  - **CURRENT POSITION** – Displays your current position.
  - **INDIVIDUAL DIRECTORY** – Manages individual MMSI numbers for making calls.
  - **GROUP DIRECTORY** – Manage MMSI groups for making calls.
  - **INDIVIDUAL REPLY** – Automates replies to calls. The screen displays:
    - Individual Call ACK
    - Position Request ACK
    - Test Call Ack

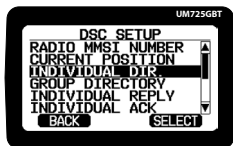
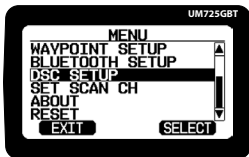

---

**Note:** Automatic acknowledgement automatically transmit your current position in response to position requests. Most boaters activate automatic position reply for safety reasons or because they subscribe to a marine towing service. Sometimes—for example, in some competitive situations—you may not want other ships to get your position without your manual confirmation.

---

- **INDIVIDUAL ACK** – Enables/disables automated acknowledgement requests.
- **INDI CALL RING** – Sets how long the alarm will sound for individual calls.
- **WAIT FOR POS FIX** – Sets how long the radio will wait for position fix requests.
- **AUTO POLLING TIME** – Sets how long the radio will wait for auto-polling requests: 30 sec, or 1, 2, 3, or 5 minutes.
- **AUTO POS POLLING** – Set how long the radio will wait for auto position fix requests.
  - **AUTO POS REQUEST** – Request positions from other individuals
  - **AUTO POS REPORT** – Report your position to other individuals.
- **DSC ALARM SETUP** – Turn alarms on and off for specific call types.

## SETTING UP DSC INDIVIDUALS AND GROUPS

Much like traditional contacts in a phone, DSC directories lets you store up to 80 individual MMSI numbers of other ships and 20 group MMSI numbers. From the directories, you can add, edit or delete MMSI numbers.

### TO MANAGE INDIVIDUAL DIRECTORY:

1. Press **MENU** button, select the **DSC SETUP** menu and press **SELECT**. The **DSC SETUP** menu appears.
2. Select **INDIVIDUAL DIR** and press **SELECT**. The **INDIVIDUAL DIR** screen appears.

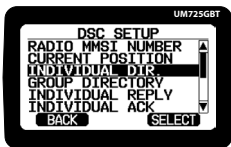

**Note:** To modify an existing individual, select **EDIT** in Step 3 and select the name from the list that appears. To delete an individual from your directory, select **DELETE**, select the individual, and then confirm.

3. Select **ADD** and press **SELECT**. **NAME** and **MMSI** appear on the screen.
4. Select **NAME** and press **SELECT**. The pop-up keyboard appears.
5. Use the keyboard to enter a name for the individual. When done, press **FINISH**. The **INDIVIDUAL DIR** screen displays again.
6. Select **MMSI** and press **SELECT**.
7. Use the keyboard to enter the ship's unique MMSI number.
8. Press **FINISH**. The **INDIVIDUAL DIR** screen displays again.
9. To save this MMSI number and name, select **SAVE**.

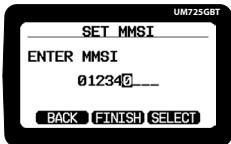
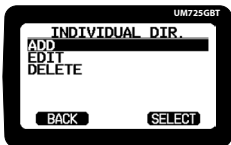

## TO MANAGE A GROUP DIRECTORY:

Unlike the user MMSI number, you can create a group MMSI number yourself, and you can also change the group MMSI number as often as you want. You don't have to get a group MMSI number from a specific organization. For example, if you are part of a boating club, your club's leadership may have a list of approved group MMSI numbers to use.

1. Press **MENU** button, select the **DSC SETUP** menu and press **SELECT**. The **DSC SETUP** menu appears.
2. Select **GROUP DIRECTORY** and press **SELECT**. The **GROUP DIRECTORY** screen appears.
3. Select **ADD** and press **SELECT**. The **ADD GROUP DIR** screen appears.

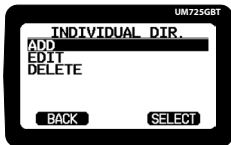

**Note:** To modify an existing group, press **EDIT** in Step 3 and select the group name from the list that appears. To delete a group from your directory, select **DELETE**, select the group, and then confirm.

4. Press **SELECT**. The pop-up keyboard appears.
5. Use the keyboard to enter a name for the group. When done, press **FINISH**. The **GROUP DIRECTORY** screen displays again.
6. Select **MMSI** and press **SELECT**.
7. Use the radio controls to enter the MMSI number for the group.

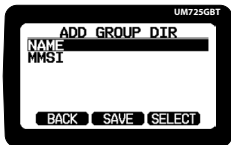

**Note:** The first digit of a group MMSI is fixed at "0."

8. When done, press **FINISH**. The **GROUP DIRECTORY** screen displays again.
9. To save this MMSI number and name, select **SAVE**.

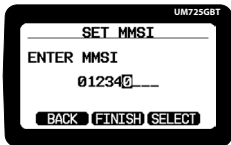

## DSC CALLS

### TO CALL AN INDIVIDUAL STATION:

1. Press the **CALL** soft key. The **CALL** menu appears.
2. Use the **PUSH/SEL** knob to select **INDIVIDUAL CALL**. The **SELECTED ID** screen appears with the list of your saved stations.
3. Use the **PUSH/SEL** knob to select the station that you want to call. The radio displays selected ship's MMSI and the transmission channel.
4. Press **SEND**. The radio transmits the call request on the selected channel. When the other station accepts the call, both radios switch to the selected response channel for voice transmission.
5. If the other station does not respond, press **RESEND** or **EXIT**.

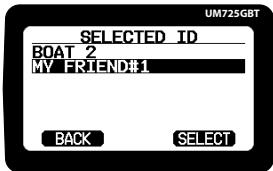
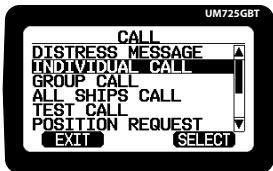

### TO CALL A GROUP:

1. Press the **CALL** soft key. The **CALL** menu appears.
2. Use the **PUSH/SEL** knob to select **GROUP CALL**. The **GROUP CALL** screen appears with the list of your saved groups.
3. Use the **PUSH/SEL** knob to select the station or group that you want to call. The radio displays selected group's MMSI and the transmission channel.
4. Press **SEND**. The radio transmits the call request on the selected channel. When a station accepts the call, both radios switch to the selected response channel for voice transmission.
5. If another station does not respond, press **RESEND** or **EXIT**.

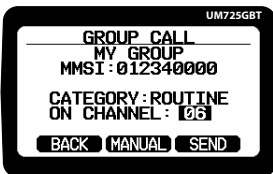
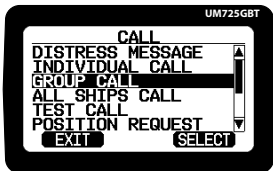

## TO CALL ALL-SHIPS:

All-ships calls contact all DSC radios within range of your ship. Only use all-ships calling in the event of a Safety warning (such as debris in the water) or to request assistance in an Urgency (any situation where your ship has a serious problem but is not yet in distress).

1. Press the **CALL** soft key. The **CALL** menu appears.
2. Use the **PUSH/SEL** knob to select **ALL SHIPS**. The ALL SHIPS CALL screen appears, showing two options: **SAFETY** and **URGENCY**.
3. Use the **PUSH/SEL** knob to select either option and then enter the channel to transmit on. Press **SEND**. The next screen displays the type of All Ships Call sent, the channel the call was sent on, and a countdown clock. If the radio receives an acknowledgement, it automatically switches to the designated response channel.
4. If the countdown clock ends, your radio will generate another countdown clock. You can either resend or cancel the call.

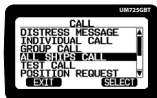
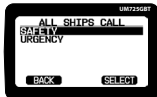

## TO RESPOND TO CALLS (INDIVIDUAL/GROUP/ALL SHIP):

If your radio receives a DSC call from another station, it sounds an incoming call alarm and displays the MMSI number of the calling station or group and the transmitting channel for the call.

1. Press the **STOP ALARM** soft key to stop the alarm. The radio will return to the main screen with the channel selected.
2. To speak to the other ship, press and hold the **Push-to-Talk** key on the microphone while talking. When you are finished talking, release the **Push-to-Talk** key to listen for a response.

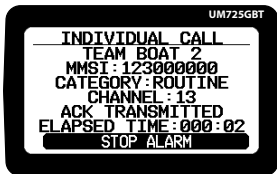

**Note:** This radio does not have the ability to acknowledge a distress call. Only the Coast Guard or an authorized Search and Rescue agency can acknowledge a DSC distress call.

## TO AUTOMATICALLY RESPOND TO CALLS

When another station sends you a range of calls, including test calls and position requests, you can select options to answer those calls manually or have the radio answer automatically.

1. Press **MENU** button, select the **DSC SETUP** menu and press **SELECT**. The **DSC SETUP** menu appears.
2. Select **INDIVIDUAL REPLY** and press **SELECT**. The **INDIVIDUAL REPLY** screen appears.
3. For each type of call received (Individual, Position Request, or Test), you can select the call type and press **SELECT**.
4. Use the **PUSH/SEL** knob to select **AUTO**

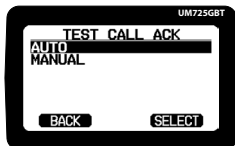
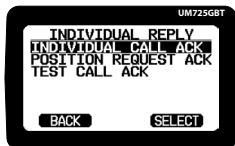
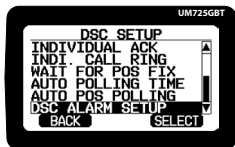

## TO MAKE A TEST CALL:

You can use the test call feature to make sure your radio is working and configured correctly. To avoid overloading coastal receiving stations, you should limit test calls to these stations to once a week.

**Note:** Many coastal stations have specific frequencies and MMSI numbers you should use for making test calls. Before making a test call to a coastal station, be sure to check the Local Notice to Mariners (LNM), issued every week by the US Coast Guard. The LNMs for each region are available online at <http://www.navcen.uscg.gov>.

1. Press the **CALL** soft key. The **CALL** menu appears.
2. Use the **PUSH/SEL** knob to select **TEST CALL**. The list of ships from your Individual Directory appears.
3. Use the **PUSH/SEL** knob to select a ship. Information for the selected station appears.
4. Press **SEND**. A WAITING FOR ACK message displays on the **TEST CALL** screen. If you do not receive an acknowledgement, either resend the transmission or select **BACK** to return to the Idle screen.

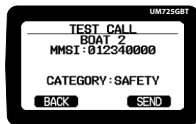
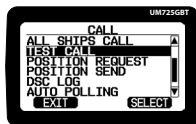

## DSC CALL LOGS

Your radio keeps track of the last 50 transmitted calls and the last 50 received in the DSC Log. If you have unread received DSC calls, the radio displays a Message icon. This is useful if you have been away from your radio and want to see who has tried to contact you.

1. Press the **CALL** soft key. The **CALL** menu appears.
2. Use the **PUSH/SEL** knob to select **DSC LOG**. The DSC LOG screen appears, showing two call logs: **TRANSMITTED LOG** and **RECEIVED LOG**.
3. Press **TRANSMITTED LOG** or **RECEIVED LOG** to see the last 50 calls of either log. Calls are listed in the order they were received, with the newest call shown first. New, unreviewed call blink on the screen.
4. Use the **PUSH/SEL** knob to select a call and review the call details. Information varies, depending on call type.

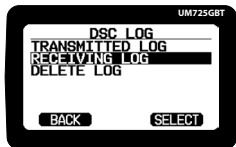
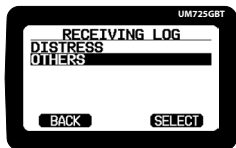

DSC Call Type	Receive Log Information
Distress	MMSI (or name), position, time, nature code.
Distress Acknowledge	MMSI (or name), distress MMSI, position, time, nature code.
All Ships	MMSI (or name), category code, communication channel number.
Group	MMSI (or name), category code, communication channel number.
Individual	MMSI (or name), category code, communication channel number.
Individual Acknowledge	MMSI (or name), Completed/Unattended, category code, communication channel number.
Test	MMSI (or name), category code.
Test Acknowledge	MMSI (or name), category code.
Pos Reply	MMSI (or name), position, time, category code.
Pos Request	MMSI (or name), category code.
Pos Send	MMSI (or name), position, time, category code.

5. To make a call from the call log, press the **CALL** soft key on the log screen.
6. To delete entries in a specific log, press **DELETE LOG**.
7. To close the log, press **EXIT**.

## MAKING A TRANSMISSION

To transmit while in any mode, select the channel you want to transmit on, and then press and hold the **Push-to-Talk** key on the microphone while talking. When you are finished talking, release the **Push-to-Talk** key to listen for a response.

- For the best sound quality, hold the microphone about two inches away from your mouth.
- To prevent stuck microphone problems or situations where the **Push-to-Talk** key is pushed accidentally, the radio limits your talk time to 5 minutes in a single transmission.

In most situations, 1W transmission power is all you need. If you are far away from other ships, you may need to increase the transmission power.

To change the power level for the current channel transmission, press the **H/L** soft key. The TX output power changes from 1W to 25W, then back again to 1W. The transmit power remains at the new setting on that channel until you change it again.



---

**Note:** Some channels (for example, channels 13 and 67) limit the transmission power to 1W. If you try to change transmission power output but the channel is only 1W, the radio sounds an error tone and stays at 1W.

---

## TO USE THE INTERCOM:

Your radio's intercom function allows you to communicate hands free in order to respond to an incoming transmission:

1. Press the **INTCOM** soft key. The radio displays INTERCOM IDLE.
2. To page the other party press and hold the **INTCOM** soft key. The radio displays INTERCOM PAGING and will send the page tone (two beep tones) to the other party.

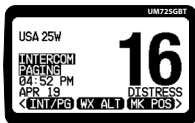
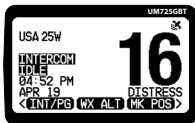



## POSITION REQUESTS

### TO MAKE A POSITION REQUEST:

Any time you need to know where another ship currently is—to find your boating partners, to respond to a request for assistance, etc.—you can send a position request to their radio.

1. Press the **CALL** soft key. The **CALL** menu appears.
2. Use the **PUSH/SEL** knob to select **POSITION REQUEST**. The POSITION REQUEST screen appears, showing the list of ships you entered into the Individual directory.
3. Use the **PUSH/SEL** knob to select a ship and press **SELECT**. The POSITION REQUEST screen displays for confirmation.
4. Press **SEND**. The radio sends out a position request to that ship and waits for acknowledgement. If you do not receive an acknowledgement, press **BACK** to return to the Idle screen.

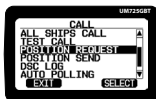

### TO SEND YOUR POSITION:

If you are requesting assistance, using an all ships call, or have received a Position Request, you can send your current position so other ships know where you are:

1. Press the **CALL** soft key. The **CALL** menu appears.
2. Use the **PUSH/SEL** knob to select **POSITION SEND**. The POSITION SEND screen appears, showing the list of ships you entered into the Individual directory.
3. Use the **PUSH/SEL** knob to select a ship (If you want to contact a station that is not in your directory, press **MANUAL** and enter the MMSI number you want to call.).
4. Press **SELECT**. The radio displays the name and MMSI number of the station you are about to contact along with your current position information.
5. Press **SEND**. The radio transmits your current position information to the other station.

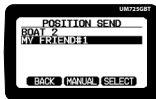
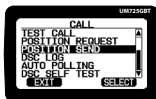

### TO USE AUTO POLLING:

Auto Polling lets you request an automatic position update from up to 7 individuals. You can also send your position automatically to up to 7 individuals.

1. Press the **CALL** soft key. The **CALL** menu appears.
2. Use the **PUSH/SEL** knob to select **AUTO POLLING**. The AUTO POLLING screen appears.

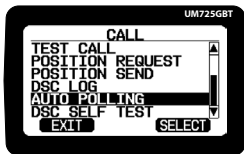

3. Press **SELECTED ID**. The SELECT ID screen appears.
4. Use the **PUSH/SEL** knob to select a row and press **SELECT**. The SELECTED ID screen displays your saved Individual Directory list.

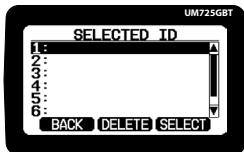

5. Use the **PUSH/SEL** knob to select a ship and press **SELECT**. The SELECTED ID list displays again with that contact listed.
6. Repeat steps 4-5 for up to 7 contacts.
7. Press **BACK**.

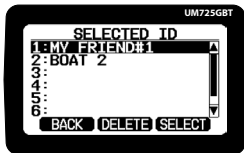

8. Use the **PUSH/SEL** knob to select **ACTIVATION** and press **SELECT**. The ACTIVATION screen appears.
9. Use the **PUSH/SEL** knob to select **START** to begin or **STOP** to end auto polling.

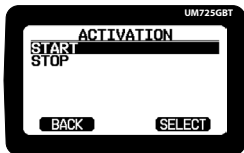

---

**Note:** A down arrow (↓) appears on the main screen when receiving polling information. An up arrow (↑) displays when sending polling information

---

### SENDING TEXT MESSAGES:

1. Press the **TEXT** soft key and select **NEW MESSAGE**. Your list of DSC contacts appears.

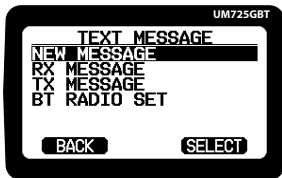

2. Use the **PUSH/SEL** knob to select an individual contact to send a message. A pop-up keyboard screen appears.

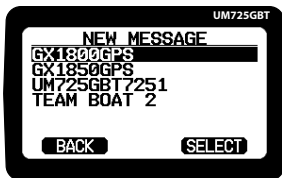

3. Enter your text message. When complete, press the **FINISH** soft button. The TX MESSAGE screen appears.



4. Press the **SEND** soft key.

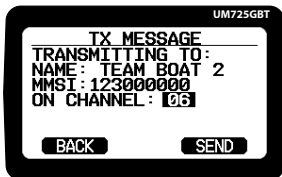

5. To review sent and received messages, press the **TEXT** soft key and select **RX MESSAGE** (received) or **TX MESSAGE** (sent).

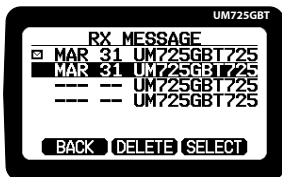

## SETTING UP BLUETOOTH (UM7250GBT ONLY):

Uniden's Marine Radio app lets you configure your UM725 and send text messages from your mobile device (available for Android and iOS).

1. Press the **MENU** button, then use the **PUSH/SEL** knob to select **BLUETOOTH SETUP**. Press the **PUSH/SEL** knob again, and the **BLUETOOTH SETUP** submenu appears.
2. (Optional) To change your radio's name, use the **PUSH/SEL** knob to select **FRIENDLY NAME** and then use the keyboard screen to set the name.
3. Use the **PUSH/SEL** knob to select **BT RADIO** and then activate Bluetooth.
4. Enable Bluetooth on the device you will be pairing to your radio.
5. Open the Uniden Marine app on your device and follow the on-screen instructions.
6. In the app, press **Search**. The Searching screen appears, followed by a list of available radios.
7. Press your radio's name when it appears. If it does not appear, move your device closer to the radio and try again.
8. Once paired, you will be able to review contacts and text messages (received and sent), and to send messages to your radio contacts.

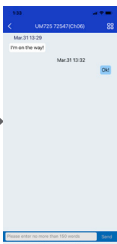
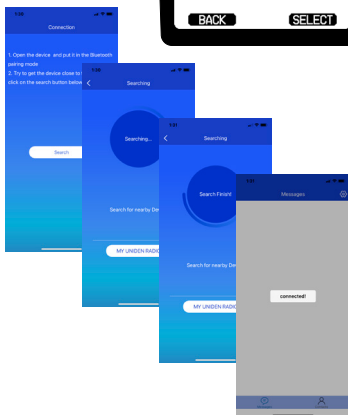
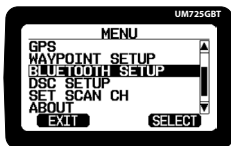

## MAKING AN AUTOMATIC DISTRESS CALL

After you have programmed your MMSI number, your radio can transmit an automated distress call on channel 16 at 25W with your current location and nature of the distress. The Distress Alert alarm sounds and the radio then monitors channel 16 for a response and repeats the distress call every few minutes until it receives an acknowledgement.

1. If you have time to select a distress message type, press the **MENU** button and use the **PUSH/SEL** knob to select **DISTRESS MESSAGE**. The Distress Message screen appears.
2. Use the **PUSH/SEL** knob to select the emergency type that most closely matches the nature of your emergency. The screen returns to the Main menu.

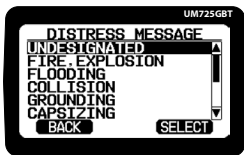

Undesignated	Sinking	Fire, Explosion	Man Overboard
Adrift	Flooding	Abandoning Ship	Capsizing
Collision	Piracy	Grounding	

---

**Note:** If no MMSI number has been programmed, the radio prompts you to enter your MMSI number.

---

3. Press and hold the **DISTRESS** key on the side of the radio for about 3 seconds. The Distress Alert alarm sounds and the radio acquires GPS location if needed.
4. After 10 seconds, the radio transmits the distress call, starts a countdown timer, and waits for an acknowledgement. After the timer counts down, another countdown timer begins unless you take action using the **PAUSE**, **CANCEL**, or **RESEND** soft keys).
5. After you receive an acknowledgement that the distress call was received, use the **MUTE** soft key to stop the acknowledgement alarm.

### **MOB Soft Key**

The Man Overboard (**MOB**) soft key does not require setup through the menus. Your radio immediately displays and saves the latitude, longitude, time, Bearing to Destination (BRG), and Distance to Destination (DIST).

1. Select the **MOB** soft key and the screen automatically marks your current location as Man Overboard. The soft keys change to **BACK**, **DEL**, and **NAV**.
  - Select **BACK** to return to the previous mode and keep the current MOB information.
  - Select **DEL** to delete the current MOB information and return to the previous mode.
  - Select **NAV** to activate the COMPASS screen and navigate to the destination.

## GPS FEATURES

The UM725 automatically acquires and saves your current GPS location when turned on. When you press the **COMP** soft key, the Compass screen appears, displaying your direction, coordinates, and local time.

**Note:** Do not let anything obstruct the antenna, such as a metal cabin ceiling. If the radio displays an Unable to Acquire message, move to an unobstructed location for the antenna.

To view satellite coverage, press the **MENU** button and use the **PUSH/SEL** knob to access the **GPS** menu and then **GPS SIGNAL COVERAGE**. The GPS SIGNAL COVERAGE screen shows satellite coverage: black dots = active satellites, white dots = inactive satellites.

To view satellite signal strength, select **SATELLITE SIGNAL** from the **GPS** menu. This will display a chart indicating satellite number and signal strength.

### TO CONFIGURE YOUR GPS:

Your GPS system is able to provide more than just your specific location. It provides several customizable features to help you get much more from your radio. Depending on your radio model and your navigation system, some options in your GPS menu will vary.

1. Press **MENU** button, and then use the **PUSH/SEL** knob to access the **GPS** menu.
2. From this menu, you can use the **PUSH/SEL** knob to access and customize GPS settings for your radio:
  - **TIME DISPLAY** – Choose between local time or UTC (UCT/GMT), and 12-hour or 24-hour display.
  - **DIRECTION** – Course Up (oriented by your course direction) or North Up (oriented to compass north).
  - **LOCATION ACCURACY** – Location in degrees (DDD), minutes (mm), and seconds (ss), or DDD.mm.mmm.
  - **UNIT OF MEASURE** – Set Speed (Knots, MPH, or KM/H), and Distance (Nautical Mile, Staute Mile, or Kilometer) as the radio's unit of measure.
  - **STATIONARY POSITION** – On/Off.
  - **NMEA INPUT PRIORITY** – Designates which received position data has priority if more than one source is active: **NMEA0183** or **NMEA2000** (UM725GBT model only).
  - **POS DATA OUTPUT** – Designates the port for position data output: **NMEA0183** or **NMEA2000**
  - **NMEA0183 OUTPUT** – Select what NMAE data is sent (UM725GBT model only).
  - **NMEA0183 DATA SPEED** – Select which NMEA data speed to use (4800 pbs or 38400 pbs) (UM725GBT model only).
  - **NMEA2000 SETUP** – Search for and configure connected NMEA 2K chartplotter (UM725GBT model only).
  - **INTERNAL GPS** – Select internal or external antenna, and power settings.

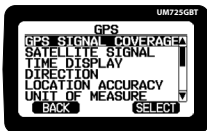
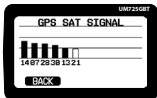
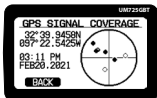
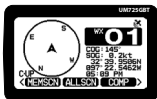

## WAYPOINTS AND ROUTES

Search the internet for the location you want. For example, search for "Key West Naval Hospital coordinates."

### TO SET UP A WAYPOINT:

1. Press **MENU** button, and then use the **PUSH/SEL** knob to access the **WAYPOINT SETUP** menu. From this menu, you can use the **PUSH/SEL** knob to define waypoints for your radio:
2. Select **WAYPOINT DIRECTORY** and press **SELECT**. The **WAYPOINT SETUP** screen appears.
3. Select **ADD** and press **SELECT**. **NAME**, **LAT**, and **LONG** appear on the screen.



**Note:** To modify an existing waypoint, select **EDIT** in Step 3 and select the waypoint name from the list that appears. To delete a waypoint from your directory, select **DELETE**, select the waypoint, and then confirm.

4. Use the **PUSH/SEL** knob to select **NAME** and press **SELECT**. The pop-up keyboard appears.
5. Use the keyboard to enter a name for the waypoint. When done, press **FINISH**. The **WAYPOINT SETUP** screen displays again.
6. Select **LAT** and press **SELECT**, then use the keyboard to enter the latitude for the waypoint.
7. When done, press **FINISH**. The **WAYPOINT SETUP** screen displays again.
8. Select **LON** and press **SELECT**, then use the keyboard to enter the longitude for the waypoint.
9. Press **SAVE**.

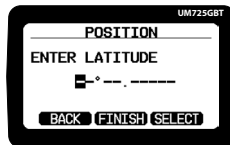
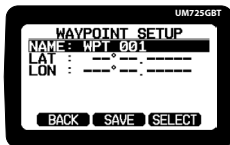

### TO SET UP A ROUTE:

1. Press **MENU** button, and then use the **PUSH/SEL** knob to access the **WAYPOINT SETUP** menu.
2. Use the **PUSH/SEL** knob to define waypoints for your radio:
3. Select **ROUTE DIRECTORY** and press **SELECT**. The **ROUTE DIRECTORY** screen appears, displaying a list of available routes.
4. Use the **PUSH/SEL** knob to select a route and press **EDIT**. **NAME** and **LIST** appear on the screen.
5. Use the **PUSH/SEL** knob to select **NAME** and press **SELECT**. The pop-up keyboard appears.
6. Use the keyboard to enter a name for the waypoint. When done, press **FINISH**. **NAME** and **LIST** appear on the screen again.
7. Select **LIST** and press **SELECT**, The **ROUTE LIST** screen appears.
8. Press the **ADD** soft key. The **POINT LIST** screen appears with a list of saved waypoints.
9. To add a waypoint, use the **PUSH/SEL** knob to select the waypoint and press **ADD**. The radio adds the waypoint to the route and returns to the **Route List** screen.
10. Repeat step 8-9 for each waypoint you want to add to the route.
11. Press **BACK**.

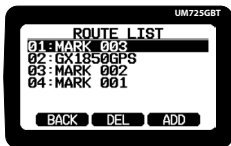
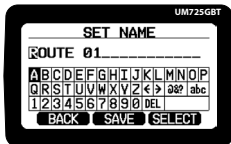
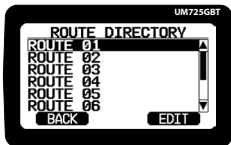



## CHARTPLOTTER CONNECTION

Your radio supports NMEA 0183 (version 4.10), a standard for data communication between marine instruments. NMEA sentences contain different sets of data related to your ship. When your radio receives another boat's position data in a DSC call, the radio sends the position data to the chartplotter so you can see the location:

Additionally, the UM725GBT model provides a NMEA 2X port for connecting to GPS along with the standard NMEA0183 GPS output that you can connect to a chartplotter.

The UM725 supports the following sentences:

DATA	RMC	GLL	GGA	GSV	GSA
UTC Time	o	O	O	X	X
Status (Valid/Invalid)	O	O	O	X	X
Latitude/Longitude	O	O	O	X	X
Speed	O	X	X	X	X
Course	O	X	X	X	X
Date	O	X	X	X	X

X = Data Not Provided

O = Data Provided

When the radio receives a DSC call (Distress, Position Reply, or Position Send), it outputs a DSC/DSE sentences from the NMEA output port in the following formats:

- \$CDDSC,12,3081234000,,07,00,0354013946,0657,,S,E\*6D
- \$CDDSE,1,1,A,3081234000,00,60875646\*13

## CHARTPLOTTER SETTINGS

If your chartplotter does not initially receive data from your radio, check that your radio and chartplotter have matching configuration. They should be set to the following parameters:

Baud rate	4800 bps
Data bits	8
Parity	None
Stop bits	1
Data amplitude	Over 3.0 V
Drive capability	Over 10 mA

*TO CONFIGURE CHARTPLOTTER SETTINGS (UM725GBT MODEL ONLY):*

1. Press **MENU** button, and then use the **PUSH/SEL** knob to access the **GPS** menu.
2. Use the **PUSH/SEL** knob to select **POS DATA OUTPUT**. Designates the port for position data output: **NMEA0183** or **NMEA2000**.
3. Select **NMEA0183 OUTPUT** to set what NMAE data is sent.
4. Select **NMEA0183 DATA SPEED** to set which NMEA data speed to use (4800 pbs or 38400 pbs).
5. Select **NMEA2000 SETUP** to search for and configure connected NMEA 2K chartplotter.

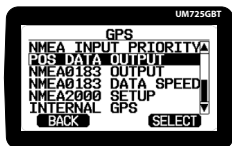

## MAINTENANCE AND TROUBLESHOOTING

Due to its rugged design, your radio requires very little maintenance. However, it is a precision electronic instrument, so you should follow a few precautions:

- If the antenna has been damaged, do not transmit except in an emergency situation. Doing so may cause further radio damage.
- You are responsible for continued FCC technical compliance of your radio.
- Arrange for periodic performance checks with your Uniden dealer.

Problem	Things to Try
The radio won't turn on.	<ul style="list-style-type: none"><li>- Verify that the battery is installed correctly.</li><li>- Charge the radio.</li></ul>
The radio won't transmit.	<ul style="list-style-type: none"><li>- Make sure you are not in Weather or Scan mode.</li><li>- Make sure you are not trying to transmit on a receive-only channel or transmit at the wrong power level for this channel (see the channel lists starting on page E-41).</li><li>- Make sure the duration of each transmission is less than 5 minutes.</li><li>- Try transmitting on a different channel.</li></ul>
I can't hear anything from the speaker.	<ul style="list-style-type: none"><li>- Adjust the squelch level; it is probably too high.</li><li>- Adjust the volume level; it is probably too low.</li></ul>
Noise comes out of the speaker all the time	Adjust the squelch level; it is probably too low.
I can transmit, but no one can hear me.	Check your UIC channel settings: does the area you are in use different channel assignments?
I'm not getting hazard alerts.	Make sure Weather Alert Watch is turned on.
The display flashes, and I don't know why.	The channel number on the display will flash if the radio is in a Watch mode or in Scan mode. Try turning off scanning, Weather Alert Watch, Triple Watch, or Dual Watch beginning on Page E-18.
Scan won't start.	Be sure you have channels saved into Favorites.
No beeps sound.	Key beep is set to OFF. Turn Key Beep on.
I cannot send DSC calls.	<ul style="list-style-type: none"><li>- Make sure the MMSI (DSC self ID) is entered.</li><li>- Turn ON the DSC Switch in the menus.</li></ul>
I cannot receive GPS position data.	Reposition the antenna so that nothing blocks it from the satellite signal.
Where can I find my radio's serial number?	The serial number is on a plate on the back of the radio..
When I turn on the radio, I get a message that "positioning data is not acquired."	Be sure there are no obstructions between the radio's antenna and the sky.

## SPECIFICATIONS

<b>General</b>	
Frequency Range	Transmitter 156.025-161.600MHz/Receiver 156.050-163.275MHz
Display	Full Dot Matrix LCD With Amber & White Cooler Back Light
Size (W/O Heatsink & Knobs)	H:3.38 X W:5.94 X 2.50 Inch ( H:85.7 X W:150.7 X L:63.5mm)
Weight	Approx. 35.3oz (1kg) With Mic
Power Supply Voltage	13.8V (10.5V - 16V) Negative Ground Only
Antenna Impedance	50 $\Omega$
Microphone	Electret Type
Speaker	4 $\Omega$ 4W (Radio) / 0.5W (Sp Mic)
Water Protect Class	IPx8
Operating Temp.range	5°F to 131°F (-15°C To +55°C)
Storage Temp.range	-22°F To 140°F (-30°C To +60°C)
<b>Transmitter</b>	
Frequency Tolerance @ 25°C	$\pm$ 2.5ppm Max.
Power Output	Hi 25W / Lo 1W
Spurious Emission	Hi Power -45dBm / Low Power -55dBm
Modulation Frequency Response	-6dB @500Hz, +6.5dB@2KHz (1KHz $\pm$ 1.0KHz Dev. Ref)
Microphone Sensitivity For $\pm$ 3khz Dev.	6mV
Hum & Noise Ratio (300hz, 3000hz Bpf 750us Deem.)	45dB
Modulation Distortion 750us Deemphasis	0.6% (0.3KHz To 3KHz B.P.H @ $\pm$ 3.0KHz Deviation)
Current Drain @ High Power	4.6A Nominal 6A Max @13.8V DC
<b>Receiver</b>	
Sensitivity for 20dB SINAD [Main] With CCITT	0.27uV
Squelch Sensitivity [Main]	Threshold 0.2uV / Tight 0.5uV
Audio Frequency Response 1KHz Reference	+6.5dB @500Hz, -6.5dB@2KHz
Adjacent Channel Selectivity	76dB @ $\pm$ 25KHz
Inter Modulation Immunity	70dB
1st & 2nd Image Rejection	80dB
1st & 2nd If Rejection	85dB

Hum & Noise Ratio	45dB
Audio Output Power @ 10% Distortion	2W Internal /2.2W External Speaker
Current Drain @No Signal	500mA MAX @No Signal/1.2A MAX at Maximum Audio Output
Battery Voltage Alert	Low 10V/High 17V
<b>GPS (UM725GBT/UM725G Only)</b>	
Acquisition Sensitivity CN	40dB (@GPS anechoic box input -103dBm)
Acquisition Time	30sec. (@GPS anechoic box input -103dBm) Limit 90sec.
<b>GPS (UM725GBT Only)</b>	
Sensitivity (Ber≤10-e5)	-90dBm(BT anechoic box input -60dBm, 1 Mbps BLE IDLE Tx)
Class / Version	BLE / V5.0

## REFERENCE TABLES

### MARINE RADIO CHANNEL CHART

The table below lists the channel display name and description used in the following tables and what each description means.

Channel Names	Description
DISTRESS SAFETY AND CALLING	primarily emergency messages and distress calls
INTERSHIP SAFETY	safety messages from one ship to another, or from a ship to Coast Guard aircraft
NON-COMMERCIAL (recreational or voluntary ships only)	messages about ship needs, including fishing reports, rendezvous, repair scheduling and berthing information
COMMERCIAL (working ships only)	messages about ship needs or ship business
PUBLIC CORRESPONDENCE/ MARINE OPERATOR	calls to the marine operator at a public coast station. Marine operators can connect to telephone networks. (There is usually a charge for this service.)
PORT OPERATIONS/VTs (ship traffic system)	messages about the movement and safety of ships in or near ports, locks or waterways. In certain major ports, some channels may be restricted to specific types of port operations messages.

Channel Names	Description
NAVIGATIONAL/BRIDGE TO BRIDGE	messages about ship navigation, for example, passing or meeting other ships, maneuvering through locks, or navigating around drawbridges. Messages must be short!
STATE CONTROL	messages about government regulation and control, boating activities, or assistance to ships; also used to talk to ships and coastal stations operated by state or local governments
DIGITAL SELECTIVE CALLING	DSC signals only (no voice communications allowed at any time)

Ch No.	TX Freq.	RX Freq.	Status	Channel Name
1001	156.0500	156.0500	Simplex	Vessel traffic system/Commercial
1003	156.1500	156.1500	Simplex	Coast guard only
1005	156.2500	156.2500	Simplex	Vessel traffic system/Commercial
6	156.3000	156.3000	Simplex	Inter-ship safety
1007	156.3500	156.3500	Simplex	Commercial
8	156.4000	156.4000	Simplex	Commercial(ship-ship)
9	156.4500	156.4500	Simplex	Non Commercial
10	156.5000	156.5000	Simplex	Commercial
11	156.5500	156.5500	Simplex	Vessel traffic system
12	156.6000	156.6000	Simplex	Vessel traffic system
13	156.6500	156.6500	Simplex, 1W	Bridge to bridge
14	156.7000	156.7000	Simplex	Vessel traffic system
15	Inhibit	156.7500	Receive Only	Environmental
16	156.8000	156.8000	Simplex	Distress, Safety, Calling
17	156.8500	156.8500	Simplex, 1W	Govt maritime control
1018	156.9000	156.9000	Simplex	Commercial
1019	156.9500	156.9500	Simplex	Commercial
20	157.0000	161.6000	Duplex	Port operations
1020	157.0000	157.0000	Simplex	Port operations
1021	157.0500	157.0500	Simplex	Coast guard only
1022	157.1000	157.1000	Simplex	Coast guard
1023	157.1500	157.1500	Simplex	Coast guard only
24	157.2000	161.8000	Duplex	Marine operator
25	157.2500	161.8500	Duplex	Marine operator

Ch No.	TX Freq.	RX Freq.	Status	Channel Name
26	157.3000	161.9000	Duplex	Marine operator
27	157.3500	161.9500	Duplex	Marine operator
28	157.4000	162.0000	Duplex	Marine operator
1061	156.0750	156.0750	Simplex	Coast guard only
1063	156.1750	156.1750	Simplex	Vessel traffic system
1064	156.2250	156.2250	Simplex	Marine operator
1065	156.2750	156.2750	Simplex	Port operations
1066	156.3250	156.3250	Simplex	Port operations
67	156.3750	156.3750	Simplex, 1W	Bridge to bridge
68	156.4250	156.4250	Simplex	Non Commercial
69	156.4750	156.4750	Simplex	Non Commercial
70	156.5250	156.5250	DSC Only	DSC
71	156.5750	156.5750	Simplex	Non Commercial
72	156.6250	156.6250	Simplex	Non Commercial(ship-ship)
73	156.6750	156.6750	Simplex	Port operations
74	156.7250	156.7250	Simplex	Port operations
75	156.7750	156.7750	Simplex, 1W	Port operations(ship-ship)
76	156.8250	156.8250	Simplex, 1W	Port operations(ship-ship)
77	156.8750	156.8750	Simplex, 1W	Port operations(ship-ship)
1078	156.9250	156.9250	Simplex	Non Commercial
1079	156.9750	156.9750	Simplex	Commercial
1080	157.0250	157.0250	Simplex	Commercial
1081	157.0750	157.0750	Simplex	Coast guard only
1082	157.1250	157.1250	Simplex	Coast guard only
1083	157.1750	157.1750	Simplex	Coast guard only
84	157.2250	161.8250	Duplex	Marine operator
85	157.2750	161.8750	Duplex	Marine operator
86	157.3250	161.9250	Duplex	Marine operator
87	157.3750	157.3750	Simplex	Port operations
88	157.4250	157.4250	Simplex	Port operations

### Canadian Frequency Chart

Ch No.	TX Freq.	RX Freq.	Status	Channel Name
1	156.0500	160.6500	Duplex	Marine operator
2	156.1000	160.7000	Duplex	Marine operator

Ch No.	TX Freq.	RX Freq.	Status	Channel Name
3	156.1500	160.7500	Duplex	Marine operator
1004	156.2000	156.2000	Simplex	Canadian coast guard
1005	156.2500	156.2500	Simplex	Vessel traffic system
6	156.3000	156.3000	Simplex	Inter-ship safety
1007	156.3500	156.3500	Simplex	Commercial
8	156.4000	156.4000	Simplex	Commercial(ship-ship)
9	156.4500	156.4500	Simplex	Boater calling channel
10	156.5000	156.5000	Simplex	Commercial
11	156.5500	156.5500	Simplex	Vessel traffic system
12	156.6000	156.6000	Simplex	Vessel traffic system
13	156.6500	156.6500	Simplex, 1W	Bridge to bridge
14	156.7000	156.7000	Simplex	Vessel traffic system
15	156.7500	156.7500	Simplex, 1W	Commercial
16	156.8000	156.8000	Simplex	Distress, Safety, Calling
17	156.8500	156.8500	Simplex, 1W	State Control
1018	156.9000	156.9000	Simplex	Commercial
1019	156.9500	156.9500	Simplex	Canadian coast guard
20	157.0000	161.6000	Duplex, 1W	Canadian coast guard
1021	157.0500	157.0500	Simplex	Canadian coast guard
2021	Inhibit	161.6500	Simplex	CMB Service
1022	157.1000	157.1000	Simplex	Canadian coast guard
23	157.1500	161.7500	Duplex	Marine operator
2023	Inhibit	161.7500	Simplex	CMB Service
24	157.2000	161.8000	Duplex	Marine operator
25	157.2500	161.8500	Duplex	Marine operator
2025	Inhibit	161.8500	Simplex	CMB Service
26	157.3000	161.9000	Duplex	Marine operator
27	157.3500	161.9500	Duplex	Marine operator
28	157.4000	162.0000	Duplex	Marine operator
2028	Inhibit	162.0000	Simplex	CMB Service
60	156.0250	160.6250	Duplex	Marine operator
1061	156.0750	156.0750	Simplex	Canadian coast guard
1062	156.1250	156.1250	Simplex	Canadian coast guard
1063	156.1750	156.1750	Simplex	Vessel traffic system
64	156.2250	160.8250	Duplex	Marine operator



Ch No.	TX Freq.	RX Freq.	Status	Channel Name
1064	156.2250	156.2250	Simplex	Marine operator
1065	156.2750	156.2750	Simplex	Port operations
1066	156.3250	156.3250	Simplex, 1W	Port operations
67	156.3750	156.3750	Simplex	Commercial
68	156.4250	156.4250	Simplex	Non Commercial
69	156.4750	156.4750	Simplex	Commercial
70	156.5250	156.5250	DSC Only	DSC
71	156.5750	156.5750	Simplex	Non Commercial
72	156.6250	156.6250	Simplex	Non Commercial
73	156.6750	156.6750	Simplex	Commercial
74	156.7250	156.7250	Simplex	Commercial
75	156.7750	156.7750	Simplex, 1W	Port operations(ship-ship)
76	156.8250	156.8250	Simplex, 1W	Port operations(ship-ship)
77	156.8750	156.8750	Simplex, 1W	Port operations(ship-ship)
1078	156.9250	156.9250	Simplex	Non Commercial
1079	156.9750	156.9750	Simplex	Commercial
1080	157.0250	157.0250	Simplex	Commercial
1081	157.0750	157.0750	Simplex	Canadian coast guard
1082	157.1250	157.1250	Simplex	Canadian coast guard
1083	157.1750	157.1750	Simplex	Canadian coast guard
2083	Inhibit	161.7750	Simplex	CMB Service
84	157.2250	161.8250	Duplex	Marine operator
85	157.2750	161.8750	Duplex	Marine operator
86	157.3250	161.9250	Duplex	Marine operator
87	157.3750	157.3750	Simplex	Port operations
88	157.4250	157.4250	Simplex	Port operations

### **International Frequency Chart**

Ch No.	TX Freq.	RX Freq.	Status	Channel Name
1	156.0500	160.6500	Duplex	Marine operator
2	156.1000	160.7000	Duplex	Marine operator
3	156.1500	160.7500	Duplex	Marine operator
4	156.2000	160.8000	Duplex	Marine operator
5	156.2500	160.8500	Duplex	Marine operator
6	156.3000	156.3000	Simplex	Inter-ship safety
7	156.3500	160.9500	Duplex	Marine operator

Ch No.	TX Freq.	RX Freq.	Status	Channel Name
8	156.4000	156.4000	Simplex	Commercial(ship-ship)
9	156.4500	156.4500	Simplex	Boater calling channel
10	156.5000	156.5000	Simplex	Commercial
11	156.5500	156.5500	Simplex	Vessel traffic system
12	156.6000	156.6000	Simplex	Vessel traffic system
13	156.6500	156.6500	Simplex	Bridge to bridge
14	156.7000	156.7000	Simplex	Vessel traffic system
15	156.7500	156.7500	Simplex, 1W	Commercial
16	156.8000	156.8000	Simplex	Distress, Safety, Calling
17	156.8500	156.8500	Simplex, 1W	Govt maritime control
18	156.9000	161.5000	Duplex	Port operations
19	156.9500	161.5500	Duplex	Port operations
1019	156.9500	156.9500	Simplex	Commercial
2019	161.5500	161.5500	Simplex	Port operations
20	157.0000	161.6000	Duplex	Port operations
1020	157.0000	157.0000	Simplex	Port operations
2020	161.6000	161.6000	Simplex	Port operations
21	157.0500	161.6500	Duplex	Port operations
22	157.1000	161.7000	Duplex	Port operations
23	157.1500	161.7500	Duplex	Marine operator
24	157.2000	161.8000	Duplex	Marine operator
25	157.2500	161.8500	Duplex	Marine operator
26	157.3000	161.9000	Duplex	Marine operator
27	157.3500	161.9500	Duplex	Marine operator
28	157.4000	162.0000	Duplex	Marine operator
60	156.0250	160.6250	Duplex	Marine operator
61	156.0750	160.6750	Duplex	Marine operator
62	156.1250	160.7250	Duplex	Marine operator
63	156.1750	160.7750	Duplex	Marine operator
64	156.2250	160.8250	Duplex	Marine operator
65	156.2750	160.8750	Duplex	Marine operator
66	156.3250	160.9250	Duplex	Marine operator
67	156.3750	156.3750	Simplex	Bridge to bridge
68	156.4250	156.4250	Simplex	Non commercial
69	156.4750	156.4750	Simplex	Port operations(ship-ship)

Ch No.	TX Freq.	RX Freq.	Status	Channel Name
70	156.5250	156.5250	DSC Only	DSC
71	156.5750	156.5750	Simplex	Port operations
72	156.6250	156.6250	Simplex	Non commercial
73	156.6750	156.6750	Simplex	Port operations(ship-ship)
74	156.7250	156.7250	Simplex	Port operations(ship-ship)
75	156.7750	156.7750	Simplex, 1W	Port operations(ship-ship)
76	156.8250	156.8250	Simplex, 1W	Port operations(ship-ship)
77	156.8750	156.8750	Simplex	Port operations(ship-ship)
78	156.9250	161.5250	Duplex	Marine operator
1078	156.9250	156.9250	Simplex	Port operations
2078	161.5250	161.5250	Simplex	Port operations
79	156.9750	161.5750	Duplex	Port operations
1079	156.9750	156.9750	Simplex	Port operations
2079	161.5750	161.5750	Simplex	Port operations
80	157.0250	161.6250	Duplex	Port operations
81	157.0750	161.6750	Duplex	Port operations
82	157.1250	161.7250	Duplex	Marine operator
83	157.1750	161.7750	Duplex	Marine operator
84	157.2250	161.8250	Duplex	Marine operator
85	157.2750	161.8750	Duplex	Marine operator
86	157.3250	161.9250	Duplex	Marine operator
87	157.3750	157.3750	Simplex	Port operations
88	157.4250	157.4250	Simplex	Port operations

### ***Weather Channels And Frequencies (Us, Can, And Intl)***

Ch No.	RX Freq	Name on display
WX01	162.5500	162.550 MHz
WX02	162.4000	162.400 MHz
WX03	162.4750	162.475 MHz
WX04	162.4250	162.425 MHz
WX05	162.4500	162.450 MHz
WX06	162.5000	162.500 MHz
WX07	162.5250	162.525 MHz
WX08	161.6500	161.650 MHz
WX09	161.7750	161.775 MHz
WX10	163.2750	163.275 MHz

## NMEA2000 PGN LIST (UM725GBT ONLY)

<b>Receive PGN:</b>
59392 ISO Acknowledgment
59904 ISO Request
60160 ISO Transport Protocol, Data Transfer
60416 ISO Transport Protocol, Connection Management
60928 ISO Address Claim
65240 ISO Commanded Address
126208 NMEA 2000 Request/Command/Acknowledgment, Group Function
126996 NMEA 2000 Product Information
127237 Heading/Track Control
127250 Vessel Heading
127258 Magnetic Variation
128259 Speed
129025 Position, Rapid Update
129026 COG and SOG, Rapid Update
129029 GNSS Position Data
129033 Local Time Offset
129539 GNSS DOPs
129540 GNSS Satellites in View

<b>Transmit PGN:</b>
59392 ISO Acknowledgment
59904 ISO Request
60928 ISO Address Claim
126208 NMEA 2000 Request/Command/Acknowledgment, Group Function
126464 NMEA 2000 Transmit/Receive PGN List, Group Function
126993 Heartbeat PGN
126996 NMEA 2000 Product Information
126998 NMEA 2000 Configuration Information
129025 Position, Rapid Update
129026 COG and SOG, Rapid Update
129029 GNSS Position Data
129539 GNSS DOPs
129540 GNSS Satellites in View
129799 Radio Frequency/Mode/Power
129808 DSC Call Information

## EMERGENCY ALERT (SAME) SYSTEM EVENT TYPES

- A **WARNING** is an event that alone poses a significant threat to public safety and/or property, probability of occurrence and location is high, and onset time is relatively short.
- A **WATCH** meets the classification of a warning, but either the onset time, probability of occurrence, or location is uncertain.
- An **EMERGENCY** is an event that, by itself, would not kill or injure or do property damage, but indirectly may cause other things to happen that result in a hazard. For example, a major power or telephone loss in a large city alone is not a direct hazard, but disruption to other critical services could create a variety of conditions that could directly threaten public safety.
- A **STATEMENT** is a message containing follow up information to a warning, watch, or emergency.

<b>Event</b>	<b>SAME Code</b>
Blizzard Warning	BZW
Coastal Flood Watch	CFA
Coastal Flood Warning	CFW
Dust Storm Warning	DSW
Extreme Wind Warning	EWV
Flash Flood Watch	FFA
Flash Flood Warning	FFW
Flash Flood Statement	FFS
Flood Watch	FLA
Flood Warning	FLW
Flood Statement	FLS
High Wind Watch	HWA
High Wind Warning	HWW
Hurricane Watch	HUA
Hurricane Warning	HUW
Hurricane Statement	HLS
Severe Thunderstorm Watch	SVA
Severe Thunderstorm Warning	SVR
Severe Weather Statement	SVS
Special Marine Warning	SMW
Special Weather Statement	SPS
Storm Surge Watch	SSA
Storm Surge Warning	SSW
Tornado Watch	TOA
Tornado Warning	TOR
Tropical Storm Watch	TRA
Tropical Storm Warning	TRW

<b>Event</b>	<b>SAME Code</b>
Tsunami Watch	TSA
Tsunami Warning	TSW
Winter Storm Watch	WSA
Winter Storm Warning	WSW
Avalanche Watch	AVA
Avalanche Warning	AVW
Child Abduction Emergency	CAE
Civil Danger Warning	CDW
Civil Emergency Message	CEM
Earthquake Warning	EQW
Evacuation Immediate	EVI
Fire Warning	FRW
Hazardous Materials Warning	HMW
Law Enforcement Warning	LEW
Local Area Emergency	LAE
911 Telephone Outage Emergency	TOE
Nuclear Power Plant Warning	NUW
Radiological Hazard Warning	RHW
Shelter in Place Warning	SPW
Volcano Warning	VOW
Administrative Message	ADR
Practice/Demo Warning	DMO
Required Monthly Test	RMT
Required Weekly Test	RWT

### ***Response Event Code***

TXB	Transmitter Backup On
TXF	Transmitter Carrier On
TXO	Transmitter Carrier On
TXP	Transmitter Primary On

# REGULATIONS AND SAFETY WARNINGS

**WARNING!** Read this information before using the radio.

## MARITIME RADIO SERVICES OPERATION

**Warning!** This transmitter will operate on channels/frequencies that have restricted use in the United States. The channel assignments include frequencies assigned for exclusive use of the U.S. Coast Guard, use in Canada, and use in international waters. Operation on these frequencies without proper authorization is strictly forbidden. See page E-41 for tables of the available channels and their uses. If you are still not certain which channels to use, see the FCC maritime radio page at the FCC website (<http://wireless.fcc.gov/marine/>) or contact the FCC Call Center at 1-888-CALL-FCC. For individuals requiring a license, such as commercial users, you should obtain a license application from your nearest FCC field office (for US users) or Industry Canada (for Canadian users).

## BASIC RADIO GUIDELINES

You should familiarize yourself with the rules on marine radios and be aware of which rules apply to your ship. Complete guidelines for all ship and marine radio types can be found at the US Coast Guard website under the topic Radio Info for Boaters (the direct link is <http://www.navcen.uscg.gov/?pageName=mtBoater>). Here are a few guidelines that affect nearly all boaters.

- If you have a VHF radio on your ship, you must maintain a watch on channel 16 (156.800 MHz) whenever the radio is not being used to communicate. Starting in 2004, if a radio is carried, it must be on and set to channel 16 whenever your ship is underway.
- If you hear a distress call, wait a few minutes to let a shore station or Coast Guard ship respond. If no other station has responded after 5 minutes, you must respond to the distress call.
- Do not make false mayday or distress calls as a prank or to test your radio. (This is essentially like making a false 9-1-1 call; you may be subject to fines.)

## FCC/Industry Canada Information

Output Power: Hi 25W / Lo 1W

Transmitter Frequency Range: 156.025-161.600MHz

This device complies with Part 15 of the FCC Rules. Operation is subject to the condition that this device does not cause harmful interference.

Unauthorized changes or modifications to this equipment may void compliance with the FCC Rules. Any change or modification must be approved in writing by Uniden. Changes or modifications not approved by Uniden could void the user's authority to operate the equipment.

## FCC RF Exposure Information

In August 1996 the Federal Communications Commission (FCC) of the United States with its action in Report and Order FCC 96-326 adopted an updated safety standard for human exposure to radio frequency electromagnetic energy emitted by FCC regulated transmitters. Those guidelines are consistent with the safety standard previously set by both U.S. and international standards bodies. The design of the radio complies with the FCC guidelines and these international standards.

Never allow children to operate the radio without adult supervision and the knowledge of the following guidelines.



**WARNING!** It is up to the user to properly operate this radio transmitter to insure safe operation. Please adhere to the following:

Use only the supplied or an approved antenna. Unauthorized antennas, modifications, or attachments could impair call quality, damage the radio, or violate FCC regulations.

Do not use the radio with a damaged antenna. If a damaged antenna comes into contact with the skin, a minor burn may result. Please contact your local dealer for a replacement antenna.

To maintain compliance with FCC RF exposure requirements, the radio must be used with a maximum duty cycle not exceeding 50% in a typical push-to-talk radio use time. DO NOT transmit for more than 50% of total radio use time.

## COMPLIANCE

### FCC Part 15

The equipment has been tested and found to comply with the limits for a Class B device, pursuant to Part 15 of the FCC rules. These limits are designed to provide reasonable protection against harmful interference in a residential installation. This equipment generates, uses, and can radiate radio frequency energy and, if not installed and used in accordance with the instructions, may cause harmful interference to radio communications. However, there is no guarantee that interference will not occur in a particular installation. If this equipment does cause harmful interference to radio or television reception, which can be determined by turning the equipment off and on, the user is encouraged to try to correct the interference by one of the following measures:

- Reorient or relocate the receiving antenna.
- Increase the separation between the equipment and the receiver
- Connect the equipment into an outlet on a circuit different from that to which the receiver is connected.
- Consult the dealer or an experienced radio/TV technician for help.

Changes or modifications not expressly approved by the party responsible for compliance could void your authority to operate the equipment. Any change or modification must be approved in writing by Uniden.

This device complies with Part 15 of the FCC rules. Operation is subject to the following two conditions: (1) This device may not cause harmful interference, and (2) this device must accept any interference received, including interference that may cause undesired operation.

Tout changement ou modification non approuvé expressément par la partie responsable pourrait annuler le droit à l'utilisateur de faire fonctionner cet équipement. Tout changement ou modification doit être approuvé par écrit par Uniden.

Avis de conformité à la FCC : Ce dispositif a été testé et s'avère conforme à l'article 15 des règlements de la Commission fédérale des communications (FCC). Ce dispositif est soumis aux conditions suivantes: 1) Ce dispositif ne doit pas causer d'interférences nuisibles et; 2) Il doit pouvoir supporter les parasites qu'il reçoit, incluant les parasites pouvant nuire à son fonctionnement.

This equipment complies with FCC radiation exposure limits set forth for an uncontrolled environment. This equipment should be installed and operated with a minimum distance of 130cm between the radiator & your body. This transmitter must not be co-located or operating in conjunction with any other antenna or transmitter.

## IC

This device contains licence-exempt transmitter(s)/receiver(s) that comply with Innovation, Science and Economic Development Canada's licence-exempt RSS(s). Operation is subject to the following two conditions:

- (1) This device may not cause interference.
- (2) This device must accept any interference, including interference that may cause undesired operation of the device.

L'émetteur/récepteur exempt de licence contenu dans le présent appareil est conforme aux CNR d'Innovation, Sciences et Développement économique Canada applicables aux appareils radio exempts de licence. L'exploitation est autorisée aux deux conditions suivantes:

- (1) L'appareil ne doit pas produire de brouillage;
- (1) L'appareil doit accepter tout brouillage radioélectrique subi, même si le brouillage est susceptible d'en compromettre le fonctionnement.

The device meets the exemption from the routine evaluation limits in section 2.5 of RSS 102 and compliance with RSS-102 RF exposure, users can obtain Canadian information on RF exposure and compliance.

Le dispositif rencontre l'exemption des limites courantes d'évaluation dans la section 2.5 de RSS 102 et la conformité à l'exposition de RSS-102 rf, utilisateurs peut obtenir l'information canadienne sur l'exposition et la conformité de rf.

This transmitter must not be co-located or operating in conjunction with any other antenna or transmitter. This equipment should be installed and operated with a minimum distance of 130 centimeters between the radiator and your body.

Cet émetteur ne doit pas être Co-placé ou ne fonctionnant en même temps qu'aucune autre antenne ou émetteur. Cet équipement devrait être installé et actionné avec une distance minimum de 130 centimètres entre le radiateur et votre corps.

## THREE-YEAR LIMITED WARRANTY

WARRANTOR: UNIDEN AMERICA CORP. ("Uniden")

ELEMENTS OF WARRANTY: Uniden warrants, for three years, to the original retail owner, this Uniden Product to be free from defects in materials and craftsmanship with only the limitations or exclusions set out below.

WARRANTY DURATION: This warranty to the original user shall terminate and be of no further effect 36 months after the date of original retail sale. The warranty is invalid if the Product is (A) damaged or not maintained as reasonable or necessary, (B) modified, altered, or used as part of any conversion kits, subassemblies, or any configurations not sold by Uniden, (C) improperly installed, (D) serviced or repaired by someone other than an authorized Uniden service center for a defect or malfunction covered by this warranty, (E) used in any conjunction with equipment or parts or as part of any system not manufactured by Uniden, or (F) installed or programmed by anyone other than as detailed by the Operating Guide for this product.

STATEMENT OF REMEDY: In the event that the product does not conform to this warranty at any time while this warranty is in effect, warrantor will repair the defect and return it to you without charge for parts, service, or any other cost (except shipping and handling) incurred by warrantor or its representatives in connection with the performance of this warranty. THE LIMITED WARRANTY SET FORTH ABOVE IS THE SOLE AND ENTIRE WARRANTY PERTAINING TO THE PRODUCT AND IS IN LIEU OF AND EXCLUDES ALL OTHER WARRANTIES OF ANY NATURE WHATSOEVER, WHETHER EXPRESS, IMPLIED OR ARISING BY OPERATION OF LAW, INCLUDING, BUT NOT LIMITED TO ANY IMPLIED WARRANTIES OF MERCHANTABILITY OR FITNESS FOR A PARTICULAR PURPOSE. THIS WARRANTY DOES NOT COVER OR PROVIDE FOR THE REIMBURSEMENT OR PAYMENT OF INCIDENTAL OR CONSEQUENTIAL DAMAGES. Some states do not allow this exclusion or limitation of incidental or consequential damages so the above limitation or exclusion may not apply to you.

LEGAL REMEDIES: This warranty gives you specific legal rights, and you may also have other rights which vary from state to state. This warranty is void outside the United States of America.

PROCEDURE FOR OBTAINING PERFORMANCE OF WARRANTY: If, after following the instructions in this Operating Guide you are certain that the Product is defective, pack the Product carefully (preferably in its original packaging). Include evidence of original purchase and a note describing the defect that has caused you to return it. The Product should be shipped freight prepaid, by traceable means, or delivered, to warrantor at:

Uniden America Corporation  
C/O Saddle Creek  
743 Henrietta Creek Rd., Suite 100  
Roanoke, TX, 76262

The background of the entire page is a technical drawing, likely a topographic map or a set of engineering plans. It features a grid of intersecting lines, some solid and some dashed. Various numerical values are scattered across the drawing, including 300, 310, 320, 330, 340, 350, 360, 370, 380, 390, 400, 410, 420, 430, 440, 450, 460, 470, 480, 490, 500, 510, 520, 530, 540, 550, 560, 570, 580, 590, 600, 610, 620, 630, 640, 650, 660, 670, 680, 690, 700, 710, 720, 730, 740, 750, 760, 770, 780, 790, 800, 810, 820, 830, 840, 850, 860, 870, 880, 890, 900, 910, 920, 930, 940, 950, 960, 970, 980, 990, and 1000. There are also some text labels like 'VAR 11° 15' W (190)' and 'ANNUAL INCREASE 6'.

**QUESTIONS?**  
Visit our website at  
[www.uniden.com](http://www.uniden.com).

**QUESTIONS?**  
Contactez-nous au  
[www.uniden.com](http://www.uniden.com).