



849 NW STATE ROAD 45
 NEWBERRY, FL 32669 USA
 PH: 888.472.2424 OR
 352.472.5500
 FAX: 352.472.2030
 EMAIL: INFO@TIMCOENGR.COM
[HTTP:// WWW.TIMCOENGR.COM](http://WWW.TIMCOENGR.COM)

**FCC PART 95 SUBPART D
 TEST REPORT
 FOR CB TRANSCEIVERS**

APPLICANT	UNIDEN AMERICA CORPORATION
	3001 GATEWAY DRIVE SUITE 130 IRVING, TEXAS 75063 USA
FCC ID	AMWUT417
MODEL NUMBER	CMX760, CMX660
PRODUCT DESCRIPTION	CB TRANSCEIVER
DATE SAMPLE RECEIVED	2/27/2017
FINAL TEST DATE	3/23/2017
TESTED BY	Frank Rose
APPROVED BY	Cory Leverett
TEST RESULTS	<input checked="" type="checkbox"/> PASS <input type="checkbox"/> FAIL

Report Number	Version Number	Description	Issue Date
331AZUT17TestReport	Rev1	Initial Issue	3/6/2017
	Rev2	Retest Ant Conducted pg 7, used modulated power for reference PO	3/23/2017
	Rev3	Updated test report with all part 95 Requirements	3/23/2017
	Rev4	Added 99% OBW and changed test procedure reference to TIA 603-D	4/7/2017

THE ATTACHED REPORT SHALL NOT BE REPRODUCED EXCEPT IN FULL WITHOUT THE WRITTEN APPROVAL OF TIMCO ENGINEERING, INC.



TABLE OF CONTENTS

GENERAL REMARKS.....	3
GENERAL INFORMATION.....	4
TEST REPORT SUMMARY.....	5
RF POWER OUTPUT	6
Test Data: Power Output Measurement Table.....	6
Test Data: DC Power Input Measurement Table.....	6
AUDIO FREQUENCY RESPONSE.....	7
Test Data: Audio Response Plot.....	7
AUDIO FREQUENCY LOW FILTER RESPONSE.....	8
Test Data: Low Filter Response Plot	8
AUDIO INPUT VS MODULATION	9
Test data: Modulation Limiting Plot	9
OCCUPIED BANDWIDTH.....	10
Test Data: 99% OBW Plot	11
Test Data: Spectrum Mask Plot	12
SPURIOUS EMISSIONS AT ANTENNA TERMINALS (CONDUCTED)	13
Test Data: Spurious Emission Measurement Table	13
FIELD STRENGTH OF SPURIOUS EMISSIONS.....	14
Test Data: Spurious Emission Measurement Table	14
FREQUENCY STABILITY.....	15
Test Data: Frequency Error Measurement Table	15
EQUIPMENT LIST	16

GENERAL REMARKS

The attached report shall not be reproduced except in full without the written permission of Timco Engineering Inc.

Summary

The device under test does:

- Fulfill the general approval requirements as identified in this test report and was selected by the customer.
- Not fulfill the general approval requirements as identified in this test report

Attestations

This equipment has been tested in accordance with the standards identified in this test report. To the best of my knowledge and belief, these tests were performed using the measurement procedures described in this report.

All instrumentation and accessories used to test products for compliance to the indicated standards are calibrated regularly in accordance with ISO 17025 requirements.

I attest that the necessary measurements were made at:

**Timco Engineering Inc.
849 NW State Road 45
Newberry, FL 32669**



Tested by:

Name and Title: Frank Rose, Project Manager/Testing Engineer

Date: 04/ 04/ 2017



Reviewed and approved by: _____

Name and Title: Cory Leverett, Engineering Project Manager

Date:04/ 04/ 2017

APPLICANT: UNIDEN AMERICA CORPORATION
FCC ID: AMWUT417
REPORT: 331AZUT17TestReport_Rev4

[TABLE OF CONTENTS](#)



GENERAL INFORMATION

EUT Specification

EUT Description	CB TRANSCEIVER
FCC ID	AMWUT417
Model Number	CMX760, CMX660
Serial Number	N/A
Operating Frequency	26.965-27.405 MHz – 40 Channel
Test Freq	27.185 MHz – CH. 19
Type of Emission	6K00A3E Bn = 2M M = 3000 Bn = 6000
Modulation	A3E
EUT Power Source	<input type="checkbox"/> 110–120Vac/50– 60Hz
	<input checked="" type="checkbox"/> DC Power (13.8 VDC)
	<input type="checkbox"/> Battery Operated Exclusively
Test Item	<input type="checkbox"/> Prototype
	<input checked="" type="checkbox"/> Pre-Production
	<input type="checkbox"/> Production
Type of Equipment	<input type="checkbox"/> Fixed
	<input checked="" type="checkbox"/> Mobile
	<input type="checkbox"/> Portable
Test Conditions	The temperature was 26°C with a relative humidity of 50-60%.
Applicable Standards	TIA-603:D, ANSI C63.4:2014 FCC CFR 47 PART 95
Modification of EUT	No modification



TEST REPORT SUMMARY

Rule Part No.	Scope of Work	Status Pass/Fail/NA
2.1046(a), 95.639	RF Power Output	Pass
2.1047(a)(b), 95.637	Modulation Characteristics	Pass
2.1049(c)(1),95.635	Occupied Bandwidth	Pass
2.1051, 95.635	Antenna Conducted Emissions	Pass
2.1053, 95.635	Field Strength Spurious Emissions	Pass
2.1055 Part 95.625	Frequency Stability	Pass

APPLICANT: UNIDEN AMERICA CORPORATION
FCC ID: AMWUT417
REPORT: 331AZUT17TestReport_Rev4

[TABLE OF CONTENTS](#)

RF POWER OUTPUT

Rule Part No.: Part 2.1033(c), Part 95.639(c)(1)

Test Requirements: 4 W Carrier power when transmitting emission type A1D or A3E

Method of Measurement: RF power is measured by connecting a 50-ohm, resistive wattmeter to the RF output connector. With a nominal battery voltage and the transmitter properly adjusted the RF output measures:

Test Data: Power Output Measurement Table

OUTPUT POWER: 3.5 Watts

Test Setup Diagram:

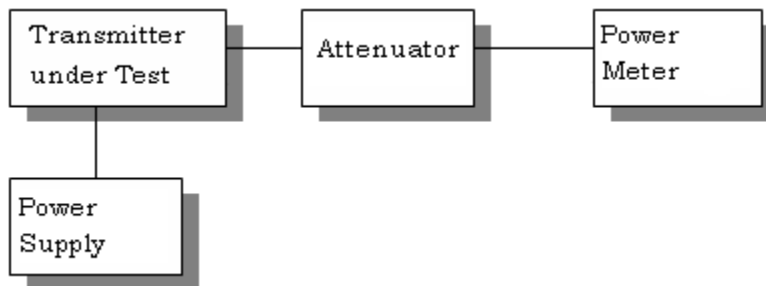

Part 2.1033 (C) (8) DC Input into the final amplifier

Test Data: DC Power Input Measurement Table

INPUT POWER: (13.8v) (1.37A) = 18.906 Watts

AUDIO FREQUENCY RESPONSE

Rule Part No.: Part 2.1047(a)

Method of Measurement:

The audio frequency response was measured in accordance with TIA-603 D with no exception. A curve or equivalent data showing the frequency response of the audio modulating circuit over a range of 100 – 5000 Hz shall be submitted. The audio frequency response curve is shown below.

Test Data: Audio Response Plot

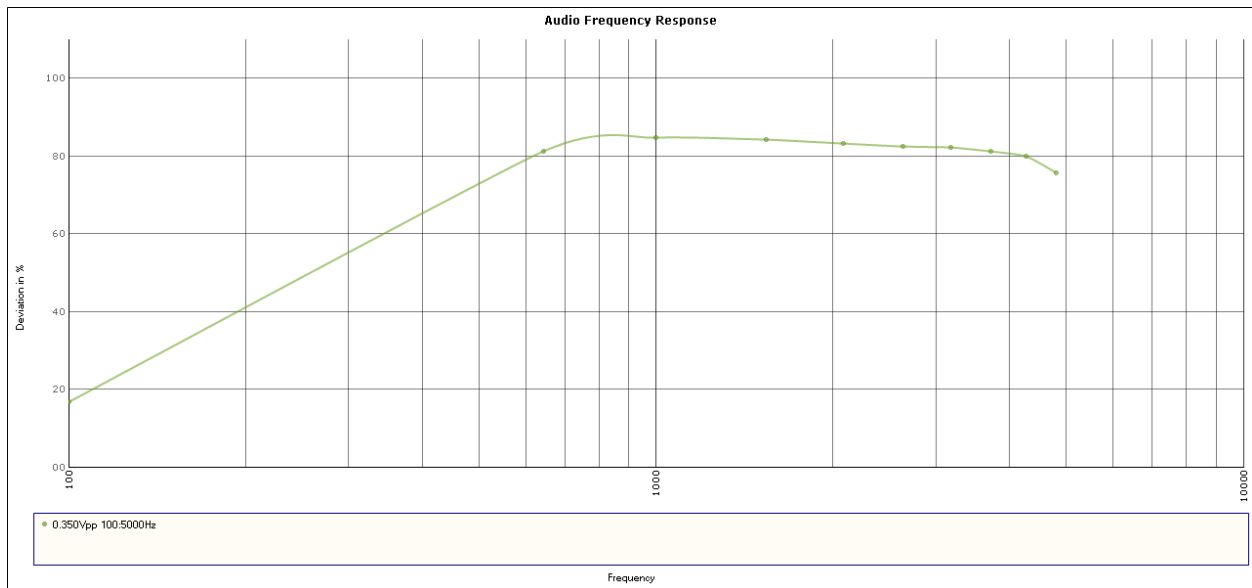

Results are for reporting Only

AUDIO FREQUENCY LOW FILTER RESPONSE

Rule Part No.: Part 2.1047(a)

Method of Measurement:

The audio frequency response was measured in accordance with TIA-603 D with no exception. A curve or equivalent data showing the frequency response of the audio low filter shall be submitted. The audio frequency low filter curve is shown below.

Test Data: Low Filter Response Plot

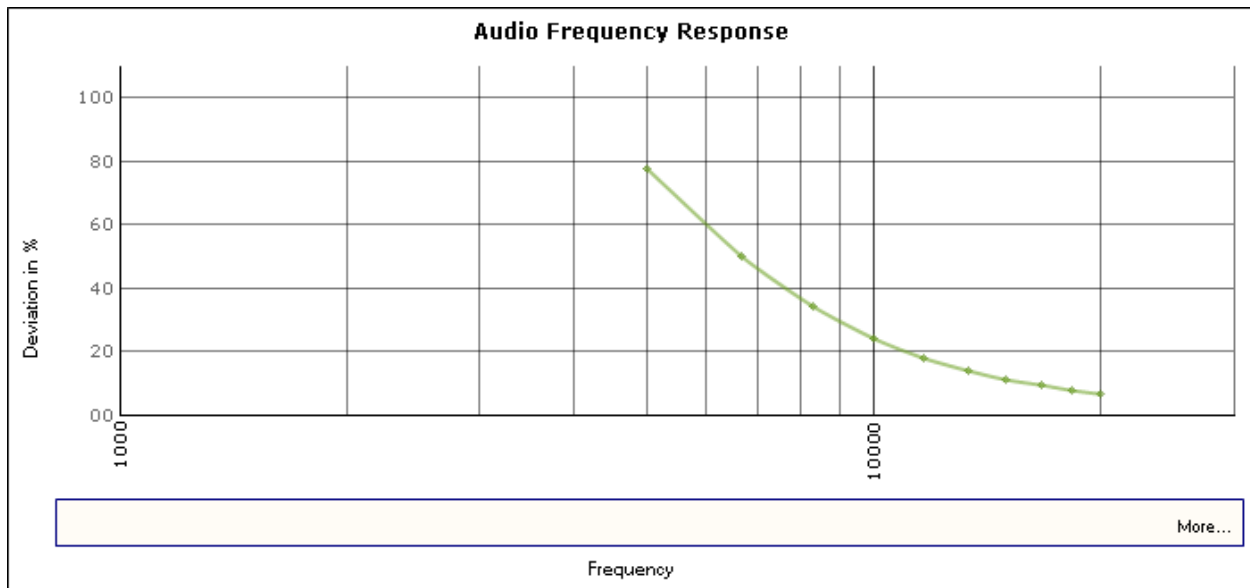

Results are for reporting Only

AUDIO INPUT VS MODULATION

Rule Part No.: Part 2.1047 (b), 95.637

Test Requirements: Modulation must be greater than 85% and cannot exceed 100%

Method of Measurement: The audio input level needed for a particular percentage of modulation was measured in accordance with TIA-603 D. The audio input curves versus modulation are shown below. Curves are provided for audio input frequencies of 300, 1000, and 3000 Hz.

Test data: Modulation Limiting Plot

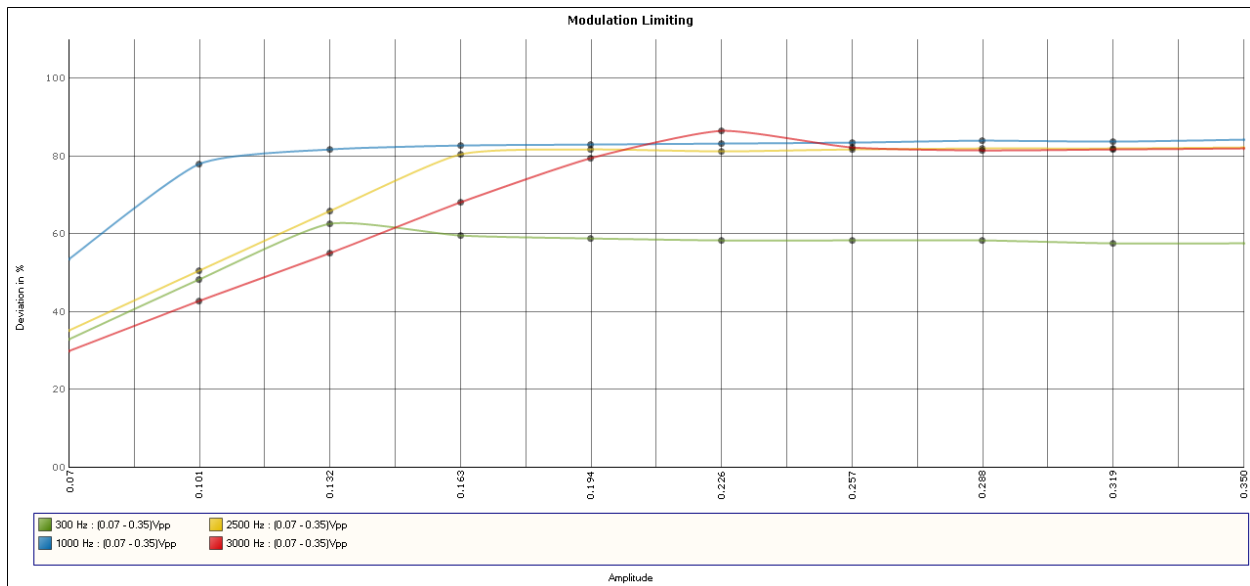

Results are for reporting Only

OCCUPIED BANDWIDTH

Rule Part No.: 2.1049, 95.631

95.631(c) Data in the plots shows that the sidebands from greater than 50% to 100% of the authorized bandwidth must be attenuated by at least 25 dB and from 100 to 250% the sidebands must be attenuated by at least 35 dB. Beyond 250% the sidebands must be attenuated by at least $53 + 10\log(TP)$. The transmitter was modulated with 2500 Hz, adjusted for 50% modulation plus 16 dB. The spectrum analyzer was set with the unmodulated carrier at the top of the screen. The test procedure diagram and occupied bandwidth photographs follow.

Test procedure diagram

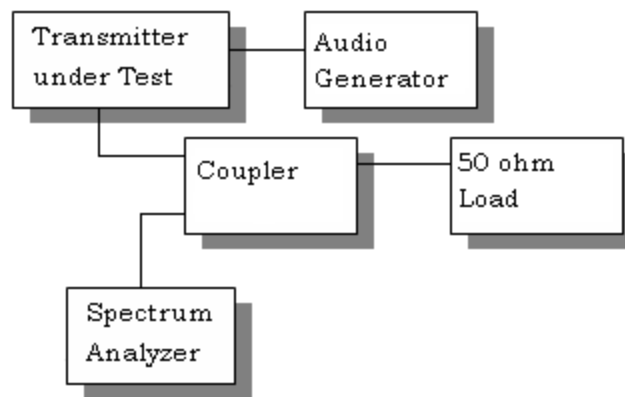

OCCUPIED BANDWIDTH PLOT

Test Data: 99% OBW Plot



Ref Lvl	Marker 1 [T1]	RBW	200 Hz	RF Att	10 dB
49.2 dBm	34.84 dBm	VBW	2 kHz		
	27.18497996 MHz	SWT	2.5 s	Unit	dBm

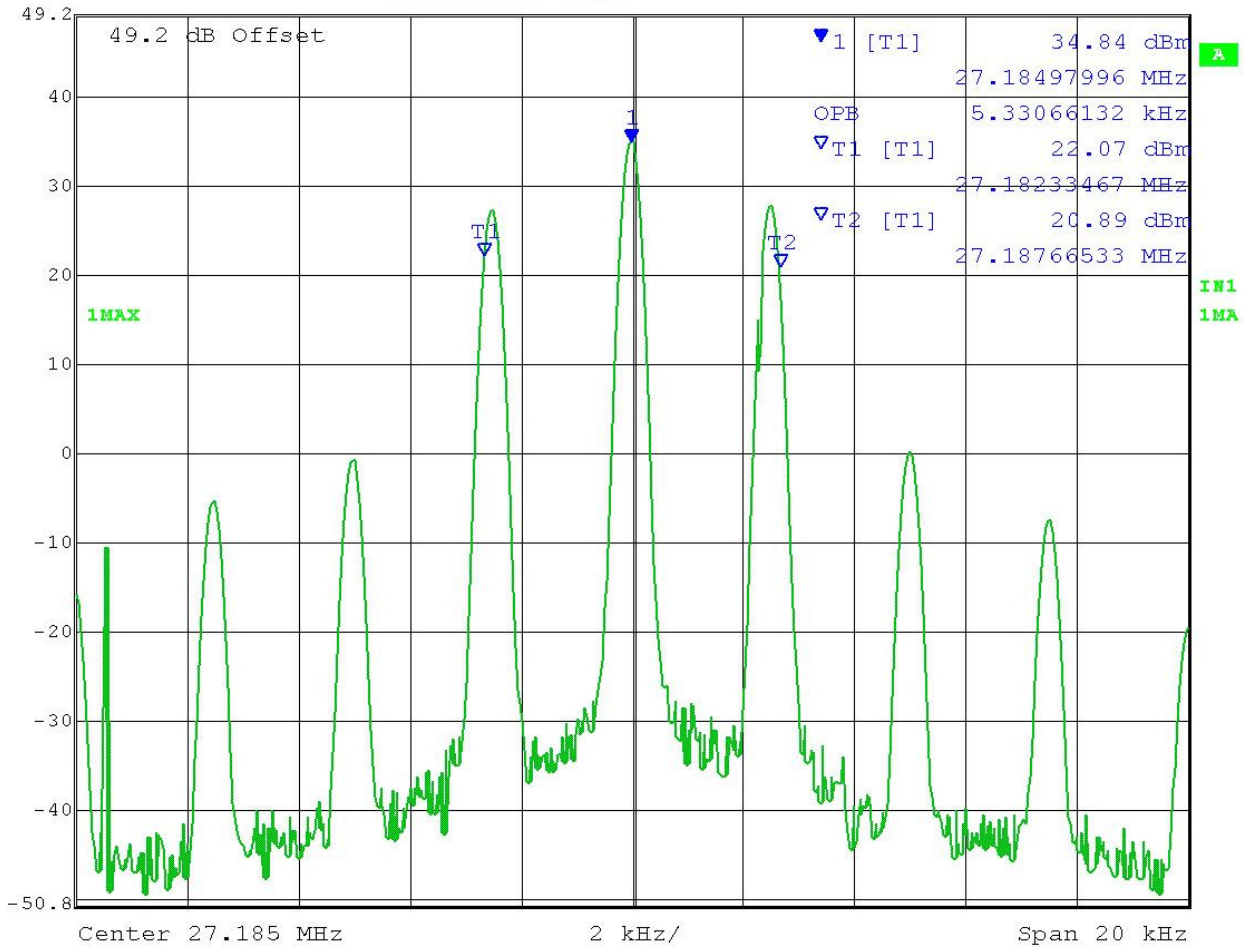

Date: 24.MAR.2017 09:57:21

OCCUPIED BANDWIDTH PLOT

Test Data: Spectrum Mask Plot



Ref Lvl
36.2 dBm

RBW	300 Hz	RF Att	20 dB
VBW	1 kHz		
SWT	5.6 s	Unit	dBm

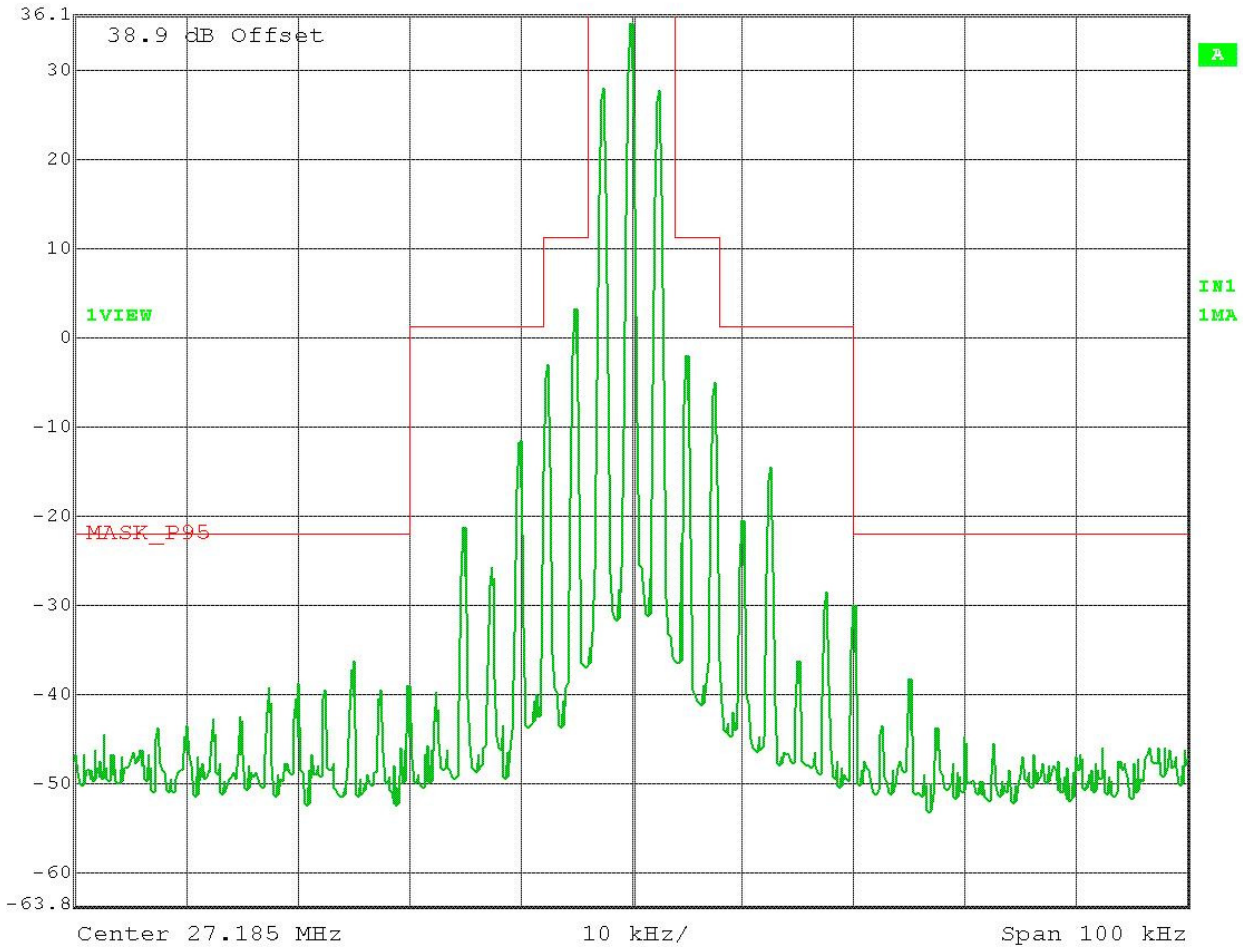

Date: 20.MAR.2017 14:59:55



SPURIOUS EMISSIONS AT ANTENNA TERMINALS (CONDUCTED)

Rule Part No.: Part 2.1051(a)

Requirements: $53 + 10 \log (TP) = \text{dBc}$. Any emissions above 54 MHz must be 60 dBc.

Method of Measurement: The carrier was modulated with a 2500 Hz tone at a level 16 dB above the level to produce 50% modulation at frequency of highest response.. The spectrum was scanned from 9 KHz to at least the 10th harmonic of the fundamental. The measurements were made in accordance with standard TIA-603 D.

Test Data: Spurious Emission Measurement Table

	dBm	Watts	Limit dBc
Modulated Power Output	41.16	13.06	60
Tuned Frequency (MHz)	Emission Frequency (MHz)	Emission Level (dBc)	Margin (dB)
27.185	54.370	63.16	3.16
	81.555	63.86	3.86
	108.740	66.66	6.66
	135.925	61.06	1.06
	163.110	63.06	3.06
	190.295	63.26	3.26
	217.480	64.86	4.86
	244.665	65.86	5.86
	271.850	69.16	9.16

FIELD STRENGTH OF SPURIOUS EMISSIONS

Rule Parts. No.: Part 2.1053, 95.635(b) (8) (9)

Requirements: Emissions must be attenuated by at least the following below the output of the transmitter.

$53 + 10\log(4.00) = 59.0 \text{ dB}$ or
FCC Limit for: 8 kHz Authorized BW

At least $53 + 10\log(T)$ dB on any frequency removed from the center of the authorized bandwidth by more than 250%. At least 60dB on any frequency twice or greater than twice the fundamental.

METHOD OF MEASUREMENT

The tabulated data shows the results of the radiated field strength emissions test. The spectrum was scanned from 9 KHz to at least the tenth harmonic of the fundamental. This test was conducted per TIA-603 D using the substitution method.

Test Setup Diagram:

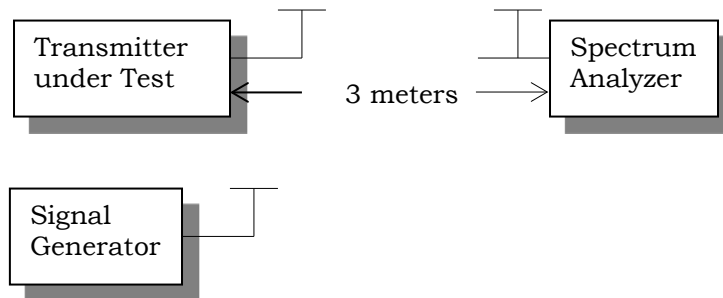

Test Data: Spurious Emission Measurement Table

Emission Frequency (MHz)	Power Mode	Power Output (dBm)	Power Output (Watts)	FCC Requirement dB	Bandwidth - BW - kHz
27.18	NA	35.44	3.50	60	6.0
Emission Frequency (MHz)	Ant. Polarity	Below Carrier (dBc)	Margin (dB)		
54.37	V	83.05	23.05		
81.56	H	88.39	28.39		
108.74	V	84.10	24.1		
135.93	V	88.89	28.89		
163.11	V	91.88	31.88		
190.30	H	92.20	32.2		
217.48	H	103.66	43.66		
244.67	V	102.79	42.79		
271.85	H	116.02	56.02		



FREQUENCY STABILITY

Rule Parts. No.: 2.1055(a) (b) (d), 95.625(b)

Requirements: must be maintained within a frequency tolerance of 0.005%.

Temperature and voltage tests were performed to verify that the frequency remains within the .005%, 50 ppm specification limit. The test was conducted as follows: The transmitter was placed in the temperature chamber at 25 °C and allowed to stabilize for one hour. The transmitter was keyed ON for one minute during which four frequency readings were recorded at 15-second intervals. The worst case number was taken for temperature plotting. The assigned channel frequency was considered to be the reference frequency. The temperature was then reduced to -30 °C after which the transmitter was again allowed to stabilize for one hour. The transmitter was keyed ON for one minute, and again frequency readings were noted at 15-second intervals. The worst case number was recorded for temperature plotting. This procedure was repeated in 10 degree increments up to + 50 °C.

Readings were also taken at ±15% of the battery voltage of 13.8 VDC.

Test Data: Frequency Error Measurement Table

Temperature	Frequency MHz	Cycles	PPM
25°C (reference)	27185006		
-30°C	27184843	-163000000	-5.996
-20°C	27185069	63000000	2.317
-10°C	27185187	181000000	6.658
0°C	27185198	192000000	7.063
10°C	27185198	192000000	7.063
20°C	27185057	51000000	1.876
30°C	27184976	-30000000	-1.104
40°C	27184900	-106000000	-3.899
50°C	27184886	-120000000	-4.414

Battery Voltage	Frequency	Cycles	PPM
-15%	27184988	-18000000	-0.662
15%	27184995	-11000000	-0.405



EQUIPMENT LIST

Device	Manufacturer	Model	Serial Number	Cal/Char Date	Due Date
12 Volt Power Supply	Astron	VS-50M	9001191	N/A	N/A
Coaxial Cable - BMBM-0065-01 Black DC-2G	Belden		BMBM-0065-01	07/18/16	07/18/18
Antenna: Biconical 1096 Chamber	Eaton	94455-1	1096	07/14/15	07/14/17
Antenna: Log-Periodic 1122	Electro-Metrics	LPA-25	1122	07/14/15	07/14/17
Temperature Chamber LARGE	Tenney Engineering	TTRC	11717-7	09/01/16	09/01/18
Digital Multimeter	Fluke	77	35053830	10/21/15	10/21/17
Frequency Counter Large Chamber	HP	5352B	2632A00165	07/01/15	07/01/17
Coaxial Cable - Chamber 3 cable set (backup)	Micro-Coax	Chamber 3 cable set (backup)	KMKM-0244-02 ; KMKM-0670-01; KFKF-0197-00	N/A	N/A
CHAMBER	Panashield	3M	N/A	04/25/16	12/31/17
Sweep/Signal Generator	Anritsu	68369B	985112	10/28/15	10/28/17
EMI Test Receiver R & S ESIB 40 Screen Room	Rohde & Schwarz	ESIB 40	100274	08/16/16	08/16/18
Software: Field Strength Program	Timco	N/A	Version 4.0	N/A	N/A
Antenna: Active Loop	ETS-Lindgren	6502	00062529	11/18/15	11/18/17
RF Power Meter	Boonton	4531	11793	01/12/17	01/12/19
Hygro-Thermometer	Extech	445703	0602	06/30/15	06/30/17
Type K J Thermometer	Martel	303	080504494	10/26/15	10/26/17
Modulation Analyzer	HP	8901A	3050A05856	04/16/15	04/16/17
EMI Test Receiver R & S ESU 40 Chamber	Rohde & Schwarz	ESU 40	100320	04/01/16	04/01/18
Attenuator N 30dB 500W DC-2.5G	Bird	8325	1761	05/18/15	05/18/17
Coaxial Cable - BMBM-0130-00 Black	Alpha Wire		BMBM-0130-00	05/24/16	05/24/18
Function Generator	Standford	DS340	25200	02/02/16	02/02/18
Tunable Notch Filter 15-30 MHz	Eagle	TNF-200	15-30 MHz (#17)	07/01/15	07/01/17
Bore-sight Antenna Positioning Tower	Sunol Sciences	TLT2	N/A	N/A	N/A
Pre-amp	RF-LAMBDA	RLNA00M45GA	N/A	01/04/16	01/04/18

* EMI RECEIVER SOFTWARE VERSION

The receiver firmware used was version 4.43 Service Pack 3

APPLICANT: UNIDEN AMERICA CORPORATION

FCC ID: AMWUT417

REPORT: 331AZUT17TestReport_Rev4

[TABLE OF CONTENTS](#)