







TEST REPORT

Eurofins KCTL Co.,Ltd. 65, Sinwon-ro, Yeongtong-gu, Suwon-si, Gyeonggi-do, 16677, Korea Tel: 82-70-5008-1021 Fax: 82-505-299-8311 www.kctl.co.kr	Report No.: KR24-SEF0097 Page (1) of (19)	 
1. Client		
<ul style="list-style-type: none"> ◦ Name : Uniden America Corporation ◦ Address : 301 International Parkway, Suite 460 Flower Mound, TX 75022 ◦ Date of Receipt : 2024-06-03 		
2. Use of Report : -		
3. Name of Product / Model : RADAR DETECTOR / R4w		
4. Manufacturer / Country of Origin : ATTOWAVE CO., LTD / Korea		
5. Date of Test : 2024-06-18		
6. Location of Test : <input checked="" type="checkbox"/> Permanent Testing Lab <input type="checkbox"/> On Site Testing (Address: 65, Sinwon-ro, Yeongtong-gu, Suwon-si, Gyeonggi-do, 16677, Korea)		
7. Test method used : ANSI C63.4:2014, FCC 02-211, Class B FCC Part 15 Subpart B		
8. FCC ID : AMWUA2401		
9. Test Results : Refer to the test result in the test report		
Affirmation	Tested by 	Technical Manager 
	Name : Mincheol Baek (Signature)	Name : Moonseop Cho (Signature)
2024-07-05		
Eurofins KCTL Co.,Ltd.		
As a test result of the sample which was submitted from the client, this report does not guarantee the whole product quality. This test report should not be used and copied without a written agreement by Eurofins KCTL Co.,Ltd.		

REPORT REVISION HISTORY

Date	Revision	Page No
2024-07-05	Originally issued	-

This report shall not be reproduced except in full, without the written approval of Eurofins KCTL Co.,Ltd. This document may be altered or revised by Eurofins KCTL Co.,Ltd. personnel only, and shall be noted in the revision section of the document. Any alteration of this document not carried out by Eurofins KCTL Co.,Ltd. will constitute fraud and shall nullify the document. This test report is a general report that does not use the KOLAS accreditation mark and is not related to KS Q ISO/IEC 17025 and KOLAS accreditation.

General remarks for test reports

Statement concerning the uncertainty of the measurement systems used for the tests

(may be required by the product standard or client)

Internal procedure used for type testing through which traceability of the measuring uncertainty has been established:

Procedure number, issue date and title:

Calculations leading to the reported values are on file with the testing laboratory that conducted the testing.

Statement not required by the standard or client used for type testing

Contents

1. Applicant information	4
2. Laboratory information	5
3. Test system configuration	6
3.1 Operation environment.....	6
3.2 Measurement Uncertainty	7
4. Description of EUT	9
4.1 General information.....	9
4.2 Product description.....	10
4.3 Auxiliary equipments	10
4.4 Test configuration	11
4.5 Operating conditions	12
5. Summary of test results	13
5.1 Summary of EMI emission test results.....	13
6. Test results	14
6.1 Radiated Emission	14

<p>Eurofins KCTL Co.,Ltd. 65, Sinwon-ro, Yeongtong-gu, Suwon-si, Gyeonggi-do, 16677, Korea Tel: 82-70-5008-1021 Fax: 82-505-299-8311 www.kctl.co.kr</p>	<p>Report No.: KR24-SEF0097 Page (4) of (19)</p>	<p> eurofins KCTL</p>
--	--	--

1. Applicant information

Applicant: Uniden America Corporation
Address: 301 International Parkway, Suite 460 Flower Mound, TX 75022

Manufacturer: ATTOWAVE CO., LTD
Address: 1005, 10F Leader's Tower, 286, Beotkkot-ro, Geumcheon-gu,
South Korea 08511



2. Laboratory information

Address

Eurofins KCTL Co.,Ltd. (Suwon Lab.)

65, Sinwon-ro, Yeongtong-gu, Suwon-si, Gyeonggi-do, 16677, Korea

Telephone Number: 82 70 5008 1021

Facsimile Number: 82 505 299 8311

FCC Site Designation No: KR0040

VCCI Registration No.: R-20080, G-20078, C-20059, T-20056

Industry Canada Registration No. : 8035A

KOLAS NO.: KT231

SITE MAP



3. Test system configuration

3.1 Operation environment

	Temperature	Humidity	Pressure
Chamber 10 m (RE)	25.8 °C	38.2 % R.H.	-

Test site

These testing items were performed following locations;

Test item	Test site
Conducted Emission	Shielded Room
Radiated Emission	10 m Chamber

3.2 Measurement Uncertainty

All measurements involve certain levels of uncertainties, especially in field of EMC.

The factors contributing to uncertainties are test receiver, cable loss, antenna factor calibration, Antenna directivity, antenna factor variation with height, antenna phase center variation, antenna frequency interpolation, measurement distance variation, site imperfection, mismatch, and system repeatability. Based on CISPR 16-4-2, the measurement uncertainty level with a 95 % confidence level was applied.

Conducted Emission measurement (Confidence level about 95 %, $k = 2$)			
Shielded Room (CE#1)	9 kHz ~ 150 kHz:	3.6 dB	
	150 kHz ~ 30 MHz:	3.1 dB	
Shielded Room (CE#2)	9 kHz ~ 150 kHz:	3.6 dB	
	150 kHz ~ 30 MHz:	3.1 dB	
Radiated Emission measurement (Confidence level about 95 %, $k = 2$)			
10 m Chamber (4F)	30 MHz ~ 1 000 MHz	3 m:	6.2 dB
		10 m:	5.0 dB
	1 GHz ~ 6 GHz	3 m:	5.5 dB
	6 GHz ~ 18 GHz	3 m:	6.1 dB
	18 GHz ~ 30 GHz	3 m:	5.2 dB
	30 GHz ~ 40 GHz	3 m:	4.7 dB
10 m Chamber (2F)	300 MHz ~ 1 000 MHz	3 m:	5.8 dB
		10 m:	4.5 dB
	1 GHz ~ 6 GHz	3 m:	5.3 dB
	6 GHz ~ 18 GHz	3 m:	6.2 dB

3.3 Measurement Program

These test items were performed by software programs;

Test item	Measurement Program		Used
Conducted Emission	EP5/CE_Ver 5.4.0(TOYO)		<input type="checkbox"/>
Radiated Emission	2F	EP10/RE_Ver 2021.01.000 (TOYO)	<input checked="" type="checkbox"/>
	4F	EP5/RE_Ver 5.11.10(TOYO)	

4. Description of EUT

4.1 General information

Radar

Receiver type : Dual conversion super-heterodyne
Antenna type : Linear polarized, self-contained
Detector type : Scanning frequency discriminator
Frequency operation : X-band; 10.525 GHz \pm 0.025 GHz
K-band; 24.075 GHz \pm 0.175 GHz
Ka-band (super-wide); 34.550 GHz \pm 1.150 GHz

Laser

Receiver type : Pulsed laser signal receiver
Detector type : Digital signal pulse width discriminator
Optical sensor : Dual convex condenser lens and high speed photo diode detector,
950nm \pm 150nm (nanometers)

General

Operating Temperature Range : -10° C to +70° C
Storage Temperature Range : -30° C to +95° C
Power requirements : 11V to 16V DC, 300 mA, negative ground
Dimensions HxWxL : 32.8 mm x 70.52 mm x 117.65 mm

4.2 Product description

Type of product	RADAR DETECTOR
Model name (Basic)	R4w
Model name (Variant)	-
Difference	-
Serial no	-
Testing voltage	DC 12 V
Input rating	DC 11 V ~ DC 16 V
Internal clock frequency	12 MHz
RF frequency	Bluetooth: 2 402 MHz ~ 2 480 MHz Wi-Fi 2.4 GHz: 2 412 MHz ~ 2 472 MHz, 2 422 MHz ~ 2 452 MHz
FCC ID	AMWUA2401
Note	-The following accessories were provided by the manufacturer. 1) Cigar Jack 2) Bluetooth/WiFi Module -FCC ID: AMWUA2404

4.3 Auxiliary equipments

Type	Model / Part #	S/N	Manufacturer
DC Power Supply	6032A	US38322201	HP
Headset	SHS-150V/W	-	SAMSUNG
Button Controller	-	-	-
Radar Detectors	R9	-	Uniden
Laser Transponders	-	-	-
Mobile Phone	SM-N976N	R3CMB08Q6VE	SAMSUNG
Radar	-	-	-

4.4 Test configuration

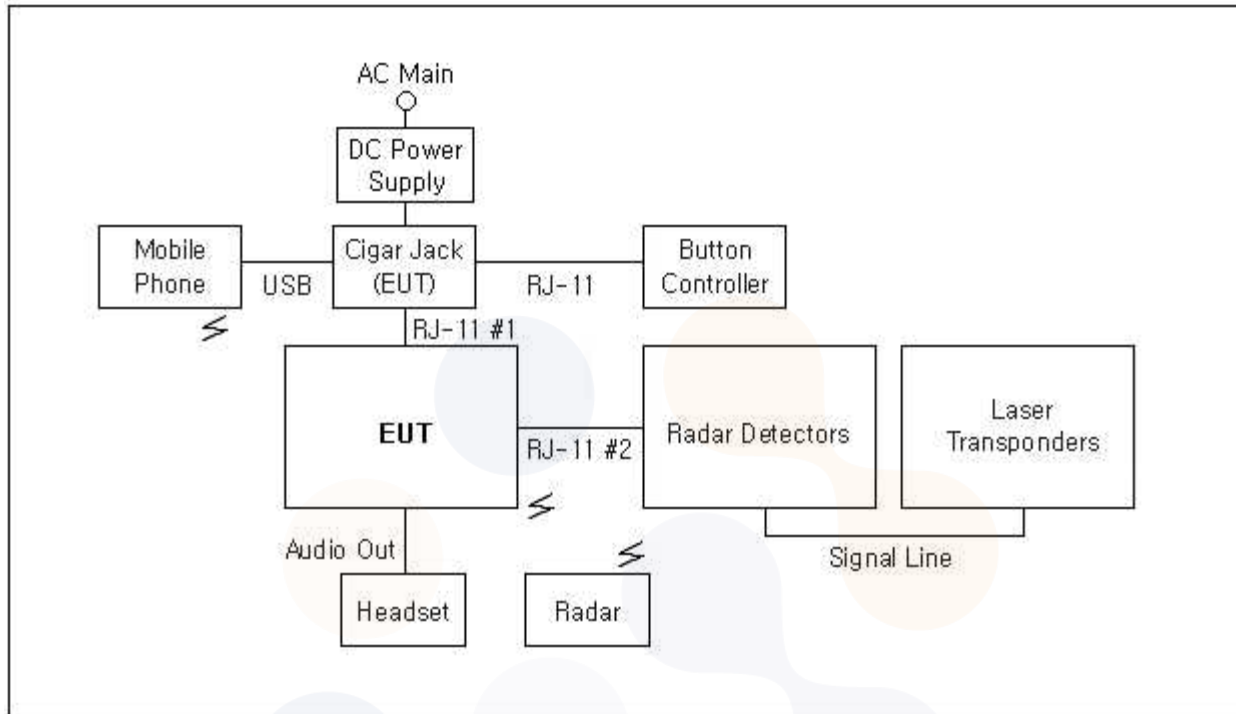

	Start		End		Cable	
	Name	I/O port	Name	I/O port	Length (m)	Spec.
1	EUT	RJ-11 #1	Cigar Jack (EUT)	-	1.5	Unshield
2		Audio Out	Headset	-	2.0	Unshield
3		RJ-11 #2	Radar Detectors	-	1.8	Unshield
4	Cigar Jack (EUT)	Power	DC Power Supply	-	1.5	Unshield
5		USB	Mobile Phone	-	0.5	Shield
6		RJ-11	Button Controller	-	2.0	Unshield
7	Radar Detectors	Signal Line	Laser Transponders	-	3.0	Unshield

4.5 Operating conditions

The EUT was configured as normal intended use.

Test mode	Normal operating					
Test #1	<p>The EUT is linked to user guidance. During the test run, the EUT operates on the following:</p> <table border="1" data-bbox="443 685 1345 882"> <tr> <td data-bbox="443 685 1345 725">Stand-by mode</td> </tr> <tr> <td data-bbox="443 725 1345 766">X Band: (10.500 ~ 10.550) GHz</td> </tr> <tr> <td data-bbox="443 766 1345 806">K Band: (23.900 ~ 24.250) GHz</td> </tr> <tr> <td data-bbox="443 806 1345 846">Ka Band(Super-wide band): (33.400 ~ 35.700) GHz</td> </tr> <tr> <td data-bbox="443 846 1345 882">Laser: (950 ± 150) nm</td> </tr> </table>	Stand-by mode	X Band: (10.500 ~ 10.550) GHz	K Band: (23.900 ~ 24.250) GHz	Ka Band(Super-wide band): (33.400 ~ 35.700) GHz	Laser: (950 ± 150) nm
Stand-by mode						
X Band: (10.500 ~ 10.550) GHz						
K Band: (23.900 ~ 24.250) GHz						
Ka Band(Super-wide band): (33.400 ~ 35.700) GHz						
Laser: (950 ± 150) nm						

5. Summary of test results

5.1 Summary of EMI emission test results

Applied	Test items	Test method	Result
<input type="checkbox"/>	Conducted Emission	ANSI C63.4:2014, FCC0 2-211 FCC Part 15 Subpart B, Class B	N/A (Note ¹⁾)
<input checked="" type="checkbox"/>	Radiated Emission	ANSI C63.4:2014, FCC 02-211 FCC Part 15 Subpart B, Class B	Pass

The data collected shows that EUT the complied with technical requirements of above rules part 15.109(h).

Note¹⁾: Report Number: (KR24-SEF0098) for AC line conducted Emissions results of the system

6. Test results

6.1 Radiated Emission

Testing voltage	DC 12 V		
Test facility	10 m Chamber (4F)		
Site validation date	Below 1 GHz	2024-03-15	
	Above 1 GHz	2023-11-20	
Test distance	3 m		
Date	2024-06-18		
Temperature (°C)	25.8 °C	Humidity (% R.H.)	38.2 % R.H.
Remarks	Pass		

6.1.1 Limits of radiated emission measurement

Frequency [MHz]	Class A at 10 m QP(dB(μV/m))		Class B at 3 m QP(dB(μV/m))	
	FCC ¹⁾	ISED (ICES Issue 7)	FCC ¹⁾	ISED (ICES Issue 7)
30-88	39.1	40.0	40.0	40.0
88-216	43.5	43.5	43.5	43.5
216-230	46.4	46.4	46.0	46.0
230-960	46.4	47.0	46.0	47.0
Above 960	49.5	49.5	54.0	54.0

- ¹⁾: Alternative standard: CISPR, Pub. 22

- Test data in this section has been taken against the FCC 15.109(a) or (B) Limit as it is the most stringent limit.

By complying with more restrictive FCC 15.109 Limit compliance with the ICES-003 Issue 7 limit also demonstrated.

6.1.2 Measurement procedure

The test was done at a 10 m chamber with a quasi-peak detector. EUT was placed on a non-metallic table height of 0.8 m above the reference ground plane. Cables were folded back and forth forming a bundle 0.3 m to 0.4 m long and were hanged at a 0.4 m height to the ground plane.

Cables connected to EUT were fixed to cause maximum emission. Test was made with the antenna positioned in both the horizontal and vertical planes of polarization. The measurement antenna was varied in height above the conducting ground plane to obtain the maximum signal strength.

6.1.3 Used equipments

Date : 2024-06-18

Equipment	Model no.	Serial no.	Makers	Next Cal. Date	Used
EMI TEST RECEIVER	ESR7	101078	R&S	2024.08.18	<input checked="" type="checkbox"/>
Antenna Mast	MA4640-XP-ET	-	Innco Systems	-	<input checked="" type="checkbox"/>
Turn Table	DT3000-2t	-	Innco Systems	-	<input checked="" type="checkbox"/>
DOUBLE RIDGED HORN ANTENNA	3117	00161083	ETS-LINDGREN	2025.02.05	<input checked="" type="checkbox"/>
AMPLIFIER	BBV9718C	00138	SCHWARZBECK	2024.10.13	<input checked="" type="checkbox"/>
EMI TEST RECEIVER	ESW44	103121	R&S	2025.05.13	<input checked="" type="checkbox"/>

6.1.4 Sample calculation

The field strength is calculated adding the antenna Factor, cable loss and, Antenna pad adding, subtracting the amplifier gain from the measured reading.

The sample calculation is as follow:

$$\text{Result} = \text{M.R} + \text{C.F}(\text{A.F} + \text{C.L} + 6 \text{ dB Att} - \text{A.G})$$

M.R = Meter Reading

C.F = Correction Factor

A.F = Antenna Factor

C.L = Cable Loss

A.G = Amplifier Gain

6 dB Att = 6 dB Attenuator

If M.R is 30 dB, A.F 12 dB, C.L 5 dB, 6 dB, A.G 35 dB

The result is $30 + 12 + 5 + 6 - 35 = 18 \text{ dB } (\mu\text{V/m})$

Bilog Antenna and ATTENUATOR (6 dB) were calibrated together.

AV = CAV : Abbreviation of CISPR Average

6.1.6 Radiated emission measurement result

11.7 GHz ~ 12.2 GHz

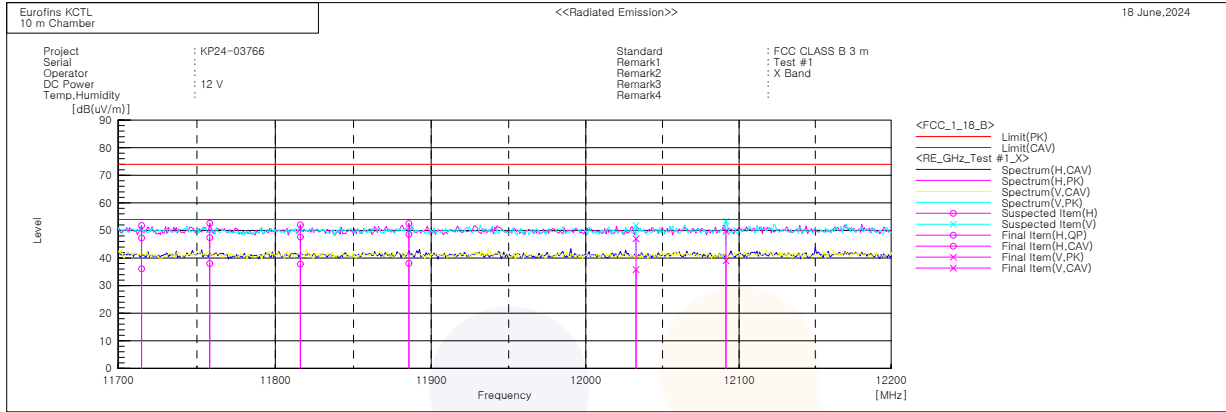

Final Result

No.	Frequency [MHz]	(P)	Reading PK [dB(uV)]	Reading CAV [dB(uV)]	c.f [dB(1/m)]	Result PK [dB(uV/m)]	Result CAV [dB(uV/m)]	Limit PK [dB(uV/m)]	Limit AV [dB(uV/m)]	Margin PK [dB]	Margin CAV [dB]	Height [cm]	Angle [deg]
1	11714.780	H	31.6	20.4	15.7	47.3	36.1	74.0	54.0	26.7	17.9	150.0	192.0
2	11758.140	H	32.0	22.6	15.4	47.4	38.0	74.0	54.0	26.6	16.0	182.0	208.0
3	11815.940	H	32.2	22.4	15.4	47.6	37.8	74.0	54.0	26.4	16.2	215.0	130.0
4	11885.640	H	32.9	22.4	15.7	48.6	38.1	74.0	54.0	25.4	15.9	350.0	260.0
5	12032.710	V	31.6	20.4	15.4	47.0	35.8	74.0	54.0	27.0	18.2	194.0	95.0
6	12091.350	V	34.1	23.4	15.7	49.8	39.1	74.0	54.0	24.2	14.9	162.0	65.0

11.7 GHz ~ 12.2 GHz

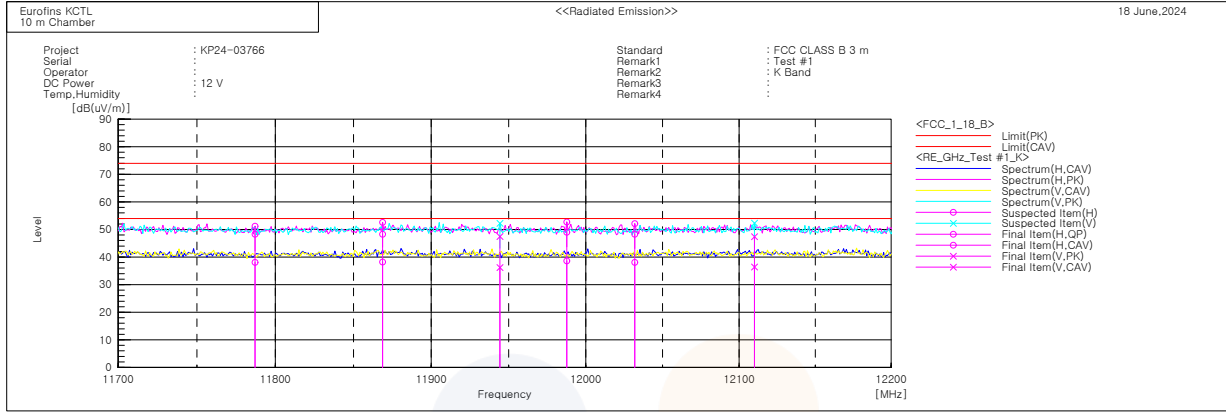

Final Result

No.	Frequency [MHz]	(P)	Reading PK [dB(uV)]	Reading CAV [dB(uV)]	c.f [dB(1/m)]	Result PK [dB(uV/m)]	Result CAV [dB(uV/m)]	Limit PK [dB(uV/m)]	Limit AV [dB(uV/m)]	Margin PK [dB]	Margin CAV [dB]	Height [cm]	Angle [deg]
1	11787.050	H	32.9	22.7	15.4	48.3	38.1	74.0	54.0	25.7	15.9	142.0	280.0
2	11868.640	H	32.6	22.5	15.7	48.3	38.2	74.0	54.0	25.7	15.8	150.0	320.0
3	11944.320	V	31.9	20.6	15.6	47.5	36.2	74.0	54.0	26.5	17.8	182.0	265.0
4	11987.660	H	33.6	23.2	15.4	49.0	38.6	74.0	54.0	25.0	15.4	310.0	137.0
5	12031.850	H	32.9	22.7	15.4	48.3	38.1	74.0	54.0	25.7	15.9	225.0	20.0
6	12110.050	V	31.6	20.6	15.8	47.4	36.4	74.0	54.0	26.6	17.6	137.0	95.0

11.7 GHz ~ 12.2 GHz

