

# AMUT05 eSense Flex V2 TAG SPECIFICATIONS

---

[CONFIDENTIAL]



©Copyright SCR Engineers LTD. 2016

This eSense Flex V2 TAG Specification is copyrighted. All rights are reserved and no part of this publication may be reproduced or transmitted in any form or by any means without prior written consent.

### **Disclaimer**

The information in this manual was accurate and reliable at the time of its release. However, we reserve the right to change the specifications of the product described in this manual without notice at any time.

### **Registered Trademarks**

All other proprietary names mentioned in this manual are the trademarks of their respective owners.

#### **Revision 0.5**

Issued by: Zeev Kapelnik

Approved by:

**September 2020**

**Version History:**

<b>1</b>	Initial version
<b>2</b>	Brand name update - SCR
<b>3</b>	Add IC ID and certification warnings for NA and CN
<b>4</b>	Add Regulatory ID by e-labeling
<b>5</b>	Product name update to eSense Flex V2

**Contents**

1	Global system specifications .....	6
1.1	System components .....	6
2	eSense Flex V2 TAG Specifications .....	6
2.1	General description .....	6
2.2	2.4GhZ Transceiver Parameters .....	7
2.3	TAG – BU/SH communication overview .....	7
2.4	NFC Parameters .....	7
2.5	Mechanical dimensions .....	8
2.6	Block diagram .....	9
3	Environmental Conditions .....	9
4	eSense Flex V2 TAG Installation instructions .....	9
5	Product marking – Regulatory ID – e-Labeling .....	11

## **FCC warning:**

**eSense Flex V2 TAG**

**FCC ID: AMUT05**

Manufacturer: SCR Engineers Ltd.

This device complies with Part 15 of the FCC Rules.

Operation is subject to the following two conditions:

This device may not cause harmful interference, and this device must accept any interference received, including interference that may cause undesired operation.

## **The FCC Wants You to know**

This equipment has been tested and found to comply with the limits for a Class B digital device, pursuant to part 15 of the FCC Rules. These limits are designed to provide reasonable protection against harmful interference in a residential installation. This equipment generates, uses and can radiate radio frequency energy and, if not installed and used in accordance with the instructions, may cause harmful interference to radio communications. However, there is no guarantee that interference will not occur in a particular installation. If this equipment does cause harmful interference to radio or television reception, which can be determined by turning the equipment off and on, the user is encouraged to try to correct the interference by one or more of the following measures:

- a) Reorient or relocate the receiving antenna.
- b) Increase the separation between the equipment and receiver.
- c) Connect the equipment into an outlet on a circuit different from that to which the receiver is connected.
- d) Consult the dealer or an experienced radio/TV technician for help.

## **FCC Warning**

Modifications to this equipment not expressly approved by the party responsible for compliance (SCR Engineers Ltd.) could void the user's authority to operate the equipment under FCC Rules.

## **ISED Warning**

SCR engineers Ltd n'approuve aucune modification apportée à l'appareil par l'utilisateur, quelle qu'en soit la nature. Tout changement ou modification peuvent annuler le droit d'utilisation de l'appareil par l'utilisateur.

## **RF Exposure Warnings**

RF Exposure - This device has been tested for compliance with FCC RF exposure limits in a portable configuration. This device must not be used with any other antenna or transmitter that has not been approved to operate in conjunction with this device.

## **Industry Canada Notice:**

### **IC: 26436-AMUT05**

- This Class B digital apparatus complies with Canadian ICES-003.
- Cet appareil numérique de la classe B est conforme à la norme NMB-003 du Canada.

This device complies with Industry Canada ICES-003 licence-exempt RSS standard(s).

Operation is subject to the following two conditions: (1) this device may not cause interference, and (2) this device must accept any interference, including interference that may cause undesired operation of the device.

Le présent appareil est conforme aux CNR d'Industrie Canada applicables aux appareils radio exempts de licence. L'exploitation est autorisée aux deux conditions suivantes :

(1) l'appareil ne doit pas produire de brouillage, et (2) l'utilisateur de l'appareil doit accepter tout brouillage radioélectrique subi, même si le brouillage est susceptible d'en compromettre le fonctionnement.

### **Interference statement**

This device complies with Part 15 of the FCC Rules and Industry Canada licence-exempt RSS standard(s). Operation is subject to the following two conditions: (1) this device may not cause interference, and (2) this device must accept any interference, including interference that may cause undesired operation of the device.

Le présent appareil est conforme aux CNR d'Industrie Canada applicables aux appareils radio exempts de licence. L'exploitation est autorisée aux deux conditions suivantes : (1) l'appareil ne doit pas produire de brouillage, et (2) l'utilisateur de l'appareil doit accepter tout brouillage radioélectrique subi, même si le brouillage est susceptible d'en compromettre le fonctionnement.

### **Wireless notice**

This device complies with FCC/ISED radiation exposure limits set forth for an uncontrolled environment and meets the FCC radio frequency (RF) Exposure Guidelines and RSS-102 of the ISED radio frequency (RF) Exposure rules. This transmitter must not be co-located or operating in conjunction with any other antenna or transmitter.

Le présent appareil est conforme à l'exposition aux radiations FCC / ISED définies pour un environnement non contrôlé et répond aux directives d'exposition de la fréquence de la FCC radiofréquence (RF) et RSS-102 de la fréquence radio (RF) ISED règles d'exposition. L'émetteur ne doit pas être colocalisé ni fonctionner conjointement avec à autre antenne ou autre émetteur.

# 1 Global system specifications

All units are for outdoor use, required Radio regulations according to target market & Low voltage 24VDC regulation (except for tags powered by internal battery).

## 1.1 System components

**eSense Flex V2 TAG** – Activity-based tag with 2.4GhZ transceiver.

BU-500 – LD Base unit, with RS-485 network interface and 2.4GhZ transceiver.

BU-500E – LD Base unit, with 10BASE-T/100BASE-TX Ethernet network interface and 2.4GhZ transceiver.

SHC – SenseHub Controller – same communication protocol with TAGs as BUxxx

# 2 eSense Flex V2 TAG Specifications

## 2.1 General description

Brand Nme:- SCR

Product Name:- eSencse Flex V2 TAG

Model Number: AMUT05

- Dairy/Beef cow ear tag
- Includes LED indicator (operation depends on system SW)
- Basic operational functionality:
  1. Identification of animals using 2.4GHz transceiver and/or HFC reader unit.
  2. Measure various animal parameters, processes and transmit them via 2.4 GHz to the base unit (BU500/E or SHC).
  3. The tag transmits a message 4ms/Hour.
  4. Outdoor installation, sealed unit, powered from internal 3V battery.



## 2.2 2.4GHz Transceiver Parameters

**RF Transceiver:** Part of SOC SiLabs EFR32FG14P232F256GM32-B

**RF Frequency:** 2.405-2.48GHz

**Modulation type:** QPSK

**RF Channels:** 5MHz separation 16ch

**Occupied Bandwidth:** 2.25MHz

**Baud Rate:** 250Kbps

**Output power:** 4dBm max

**Antenna type:** PCB Omni-directional

**Antenna gain:** Average -6.94dBi (Max gain: -1.69dBi) – final TBD

**Average RF data:** TX - 2 msg of 4ms every 20min; Rx - 4 msg/hour of 1ms

## 2.3 TAG – BU/SH communication overview

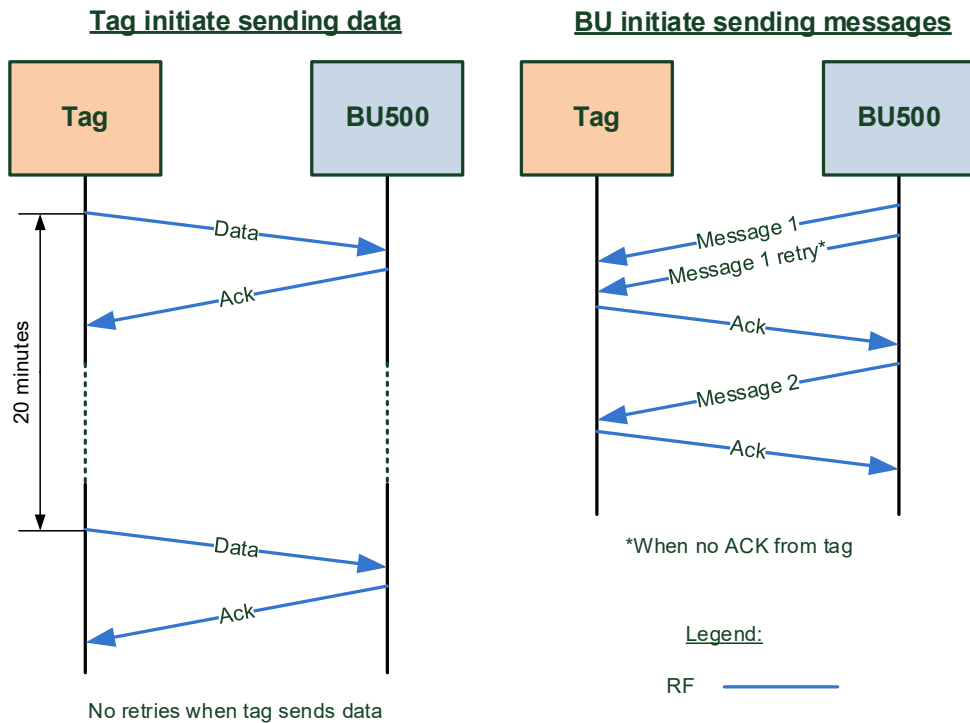

## 2.4 NFC Parameters

Utilizing **Passive** internal NFC High-Frequency inlay (IC and Antenna) complying with the following standards

- ISO/IEC 15693-2, -3
- ISO/IEC 18000-3 Compliant
- 13.56-MHz Operating Frequency

## 2.5 Mechanical dimensions

All dimensions in mm

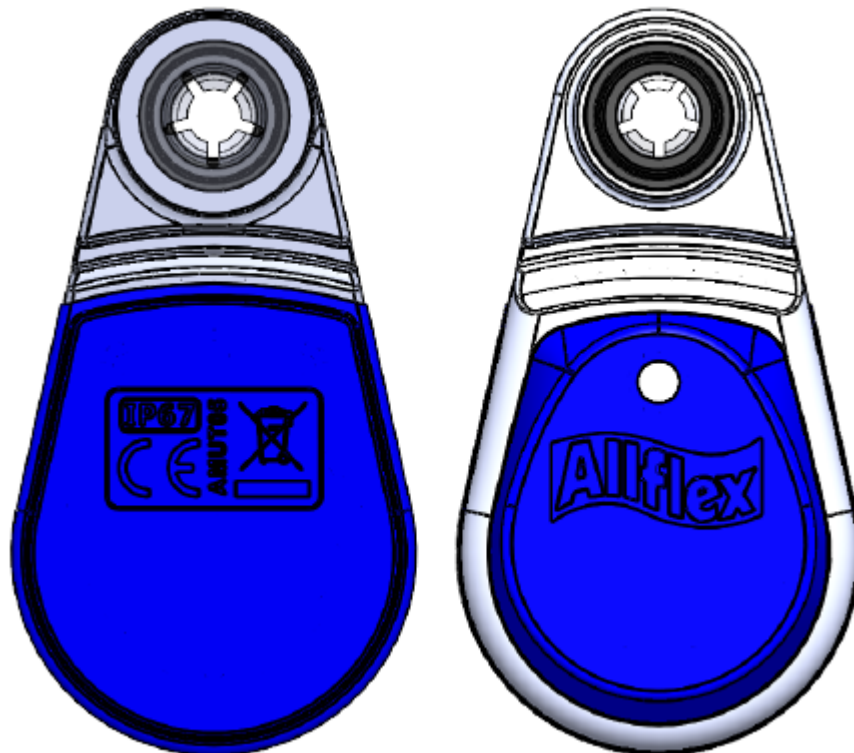
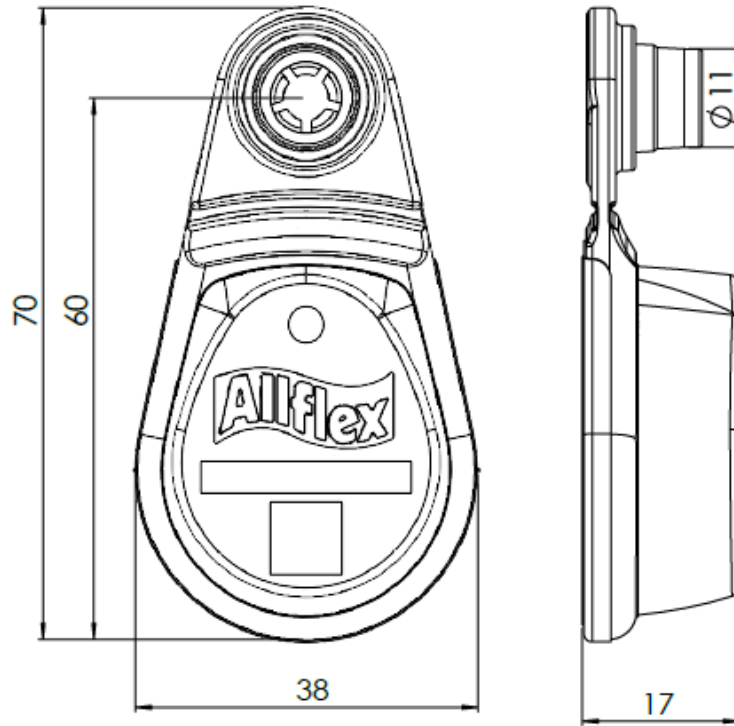



## 2.6 Block diagram

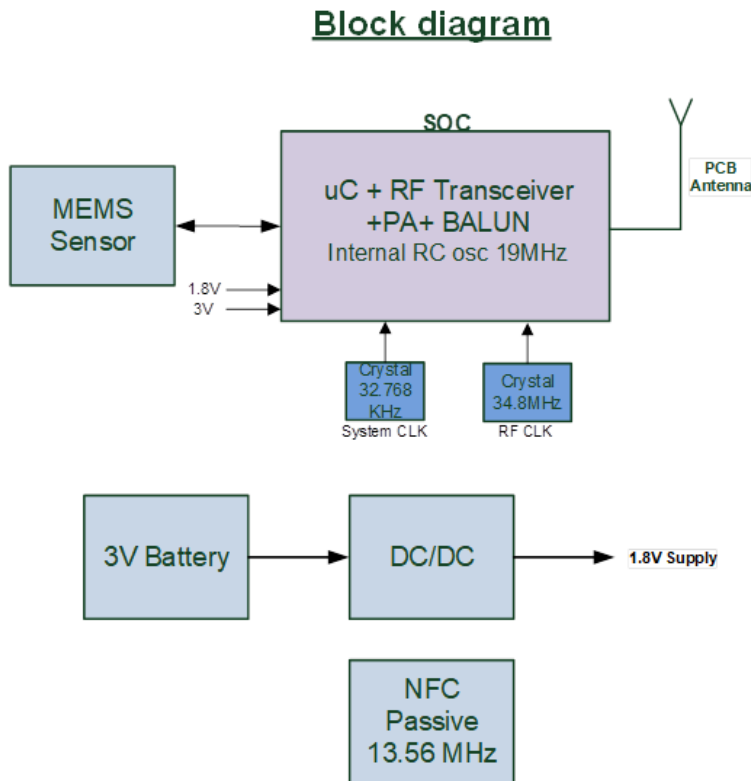

## 3 Environmental Conditions

1. **IP – required IP67.**
2. **Operational temperature** -33°C to 50°C.
3. **Storage** – TBD
4. **Transportation**  
Complies with ETS 300 019 -2-2 T2.3  
Complies with ETS 300 019 -2-1 T 1.2

## 4 eSense Flex V2 TAG Installation instructions

It is important to correctly attach the tags to the cow's ear in a secure manner to avoid them from turning or falling off.

To securely attach the tag to the cow's ear:

1. Ensure that your tag assembly kit includes the following parts:
  - i. eSense Flex V2 TAG

ii. Pins – optional MO5 1195 or similar as will be decided in future



iii. Applicator - Universal tagger



**A properly mounted tag should look like this picture:**

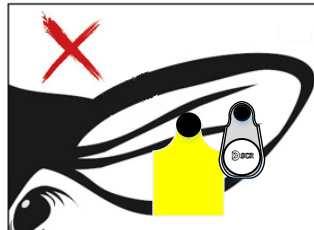
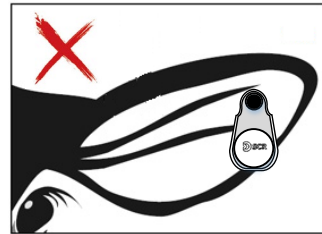
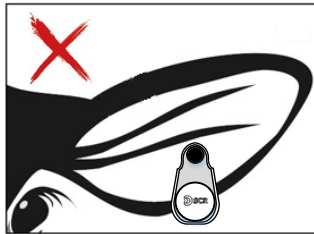

## 5 Product marking – Regulatory ID – e-Labeling

As product too small we will mark the regulatory ID as required by e-labeling on user operation system as below chart

