

FCC PART 15C TEST REPORT FOR CERTIFICATION
On Behalf of

Shenzhen Doking Electronic Technology Co.,Ltd

2.4G Wireless Mouse

Model Number: DOK-M159W

FCC ID: AMRM159W

Prepared for : Shenzhen Doking Electronic Technology Co.,Ltd
Dingfeng Hi-tech Estate, Shapu, Songgang Town, Baoan
District, Shenzhen

Prepared By : EST Technology Co., Ltd.
Santun(guantai Road), Houjie Town,
DongGuan City,GuangDong, China.

Tel: 86-769-83081888-808

Report Number : ESTE-R1112011
Date of Test : Dec.1-Dec.16, 2011
Date of Report : Dec.19, 2011

TABLE OF CONTENTS

	<u>Description</u>	<u>Page</u>
1.	SUMMARY OF STANDARDS AND RESULTS.....	1-1
1.1.	Description of Standards and Results	1-1
2.	GENERAL INFORMATION	2-1
2.1.	Description of Device (EUT)	2-1
2.2.	Tested Supporting System Details	2-2
2.3.	EUT Configuration and operation conditions for test.....	2-2
3.	POWER LINE CONDUCTED EMISSION TEST	3-1
4.	RADIATED EMISSION TEST	4-2
4.1.	Test Equipment	4-2
4.2.	Block Diagram of Test Setup.....	4-2
4.3.	Radiated Emission Limit Standard: FCC 15.209 and 15.249	4-3
4.4.	Operating Condition of EUT.....	4-4
4.5.	Test Procedure.....	4-4
4.6.	Radiated Emission Test Results	4-4
5.	20 DB BANDWIDTH TEST	5-1
5.1.	Test Equipment	5-1
5.2.	Limit.....	5-1
5.3.	Test Results	5-1
6.	BAND EDGE COMPLIANCE TEST	6-1
6.1.	Test Equipment	6-1
6.2.	Limit.....	6-1
6.3.	Test Produce	6-1
6.4.	Test Results	6-2
7.	PHOTOGRAPH OF TEST	7-1
7.1.	Photos of Radiated Emission Test (30-1000MHz)	7-1
8.	PHOTOGRAPH OF EUT	8-1

TEST REPORT CERTIFICATION

Applicant : Shenzhen Doking Electronic Technology Co.,Ltd
Manufacturer : Shenzhen Doking Electronic Technology Co.,Ltd
EUT Description : 2.4G Wireless Mouse
FCC ID : AMRM159W
(A) MODEL NO. : DOK-M159W
(B) SERIAL NO. : N/A
(C) POWER SUPPLY : DC 3V
(D) TEST VOLTAGE : DC 3V

Tested for comply with:
FCC Rules and Regulations Part 15 Subpart C:2008

Test procedure used:
ANSI C63.4:2003

The device described above is tested by EST Technology Co., Ltd. to confirm comply with all the FCC Part 15 Subpart C requirements.

The test results are contained in this test report and EST Technology Co., Ltd. is assumed full responsibility for the accuracy and completeness of these tests. Also, this report shows that the Equipment under test (EUT) is to be technically compliant with the FCC requirements.

Prepared by:

Tested by:

Approved by:



Ada / Assistant

Tony/ Engineer

Iceman Hu / Manager

This test report is based on a single evaluation of one sample of above mentioned products. It is not permitted to be duplicated in extracts without written approval of EST Technology Co., Ltd.

1. SUMMARY OF STANDARDS AND RESULTS

1.1. Description of Standards and Results

The EUT have been tested according to the applicable standards as referenced below.

EMISSION		
Description of Test Item	Standard	Results
Power Line Conducted Emission Test	FCC Part 15C: 15.207 ANSI C63.4-2003	N/A
Radiated Emission Test	FCC Part 15C: 15.209 FCC Part 15C: 15.249 ANSI C63.4-2003	PASS
Band Edge Compliance Test	FCC Part 15: 15.249 ANSI C63.4-2003	PASS
20dB Bandwidth Test	FCC Part 15: 15.215 ANSI C63.4-2003	PASS

2. GENERAL INFORMATION

2.1. Description of Device (EUT)

Product Name	: 2.4G Wireless Mouse
Model Number	: DOK-M159W
FCC ID	: AMRM159W
Operation frequency	: 2402MHz~2478MHz
Antenna	: Integrated PCB antenna, 1.97dBi gain
Modulation	: GFSK
Power Supply	: DC 3V from battery Note: New battery were used for all test.
Applicant	: Shenzhen Doking Electronic Technology Co.,Ltd Dingfeng Hi-tech Estate, Shapu, Songgang Town, Baoan District, Shenzhen
Manufacturer	: Shenzhen Doking Electronic Technology Co.,Ltd Dingfeng Hi-tech Estate, Shapu, Songgang Town, Baoan District, Shenzhen
Sample Type	: Prototype production

2.2. Tested Supporting System Details

N/A

2.3. EUT Configuration and operation conditions for test.

EUT

EUT work continues Tx mode and frequency as below:

Channel	Frequency
Low	2402MHz
Middle	2442MHz
High	2478MHz

Note: A typical modulation was applied when performance test.

3. POWER LINE CONDUCTED EMISSION TEST

N/A

Note: This test only apply to device powered with AC mains.

4. RADIATED EMISSION TEST

4.1. Test Equipment

Frequency rang: 30~1000MHz

Item	Equipment	Manufacturer	Model No.	Serial No.	Last Cal.	Cal. Interval
1	EMI Spectrum	Agilent	E4407B	MY41440292	May.08, 11	1 Year
2	Test Receiver	Rohde & Schwarz	ESVS10	834468/011	May.08, 11	1 Year
3	Amplifier	HP	8447D	2648A04738	May.08, 11	1 Year
4	Bilog Antenna	Schaffner	CBL6112D	25237	Mar. 27,11	1 Year
5	RF Cable	MIYAZAKI	8D-FB	3# Chamber No.1	May.08, 11	1 Year
6	Coaxial Switch	Anritsu	MP59B	M73989	May.08, 11	1 Year

Frequency rang: above 1000MHz

Item	Equipment	Manufacturer	Model No.	Serial No.	Last Cal.	Cal. Interval
1	Spectrum Analyzer	Agilent	E4446A	US44300459	May.08, 11	1 Year
2	Horn Antenna	EMCO	3115	9607-4877	May.25, 11	1.5 Year
3	Horn Antenna	EMCO	3116	00060089	May.25, 11	1.5 Year
4	Amplifier	Agilent	8449B	3008A00863	May.08, 11	1 Year
5	RF Cable	Hubersuhner	SUCOFLEX102	28620/2	May.08, 11	1 Year
6	RF Cable	Hubersuhner	SUCOFLEX102	29091/2	May.08, 11	1 Year

4.2. Block Diagram of Test Setup

For frequency range 30MHz-1000MHz

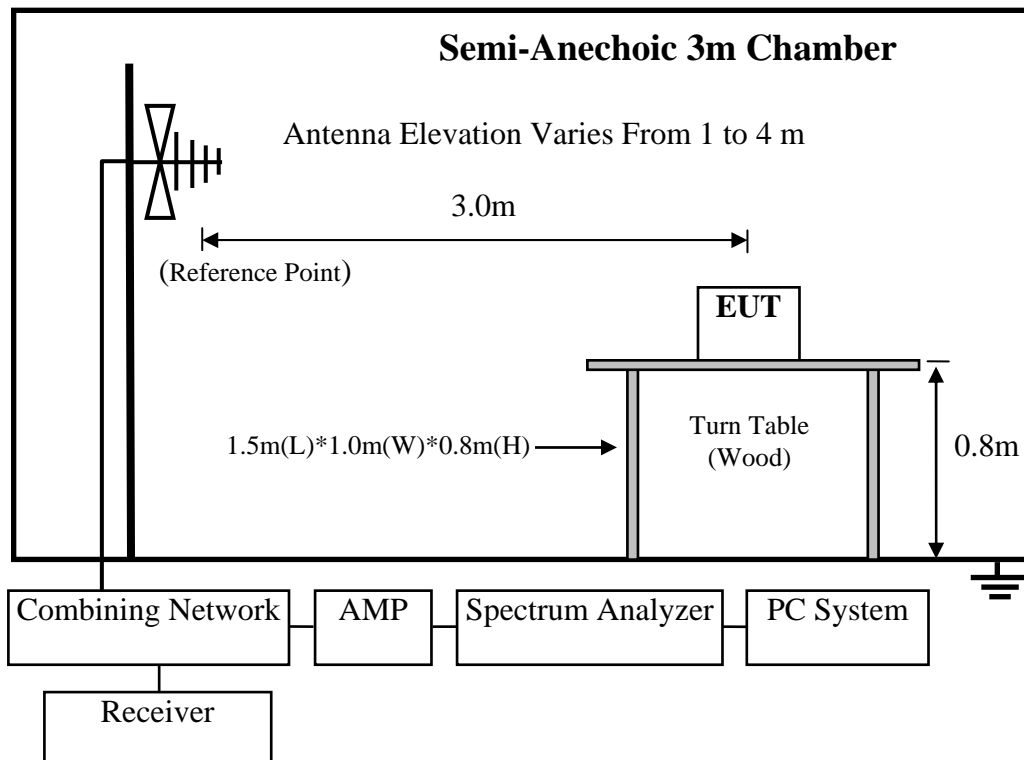

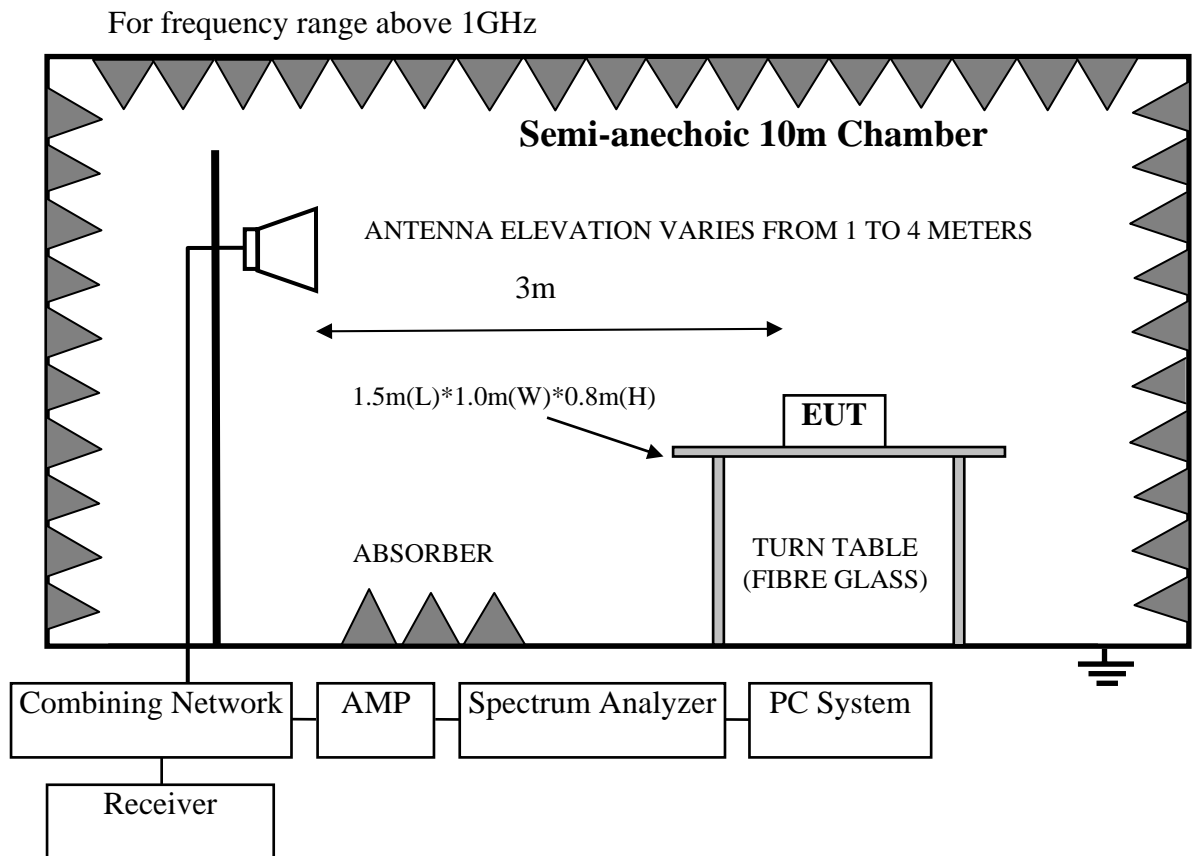

4.3. Radiated Emission Limit Standard: FCC 15.209 and 15.249

FREQUENCY MHz	DISTANCE Meters	FIELD STRENGTHS LIMIT	
		µV/m	dB(µV)/m
30 ~ 88	3	100	40.0
88 ~ 216	3	150	43.5
216 ~ 960	3	200	46.0
960 ~ 1000	3	500	54.0
Above 1000MHz	3	74.0 dB(µV)/m (Peak) 54.0 dB(µV)/m (Average)	
Field Strength of fundamental emissions for 2.4GHz-2.4835GHz	3	114.0 dB(µV)/m (Peak) 94.0 dB(µV)/m (Average)	

- Remark :
- (1) Emission level $dB\mu V = 20 \log$ Emission level $\mu V/m$
 - (2) The smaller limit shall apply at the cross point between two frequency bands.
 - (3) Distance is the distance in meters between the measuring instrument, antenna and the closest point of any part of the device or system.
 - (4) The emission limits shown in the above table are based on measurements employing a CISPR quasi-peak detector except for the frequency bands 9-90 kHz, 110-490 kHz and above 1000 MHz. Radiated emission limits in these three bands are based on measurements employing an average detector.

4.4. Operating Condition of EUT

- 4.4.1. Setup the EUT and simulator as shown as Section 4.2.
- 4.4.2. Turned on the power of all equipment.
- 4.4.3. Let EUT work in test mode (Tx mode) and test it.

4.5. Test Procedure

The EUT and its simulators are placed on a turn table, which is 0.8 meter high above ground. The turn table can rotate 360 degrees to determine the position of the maximum emission level. The EUT is set 3 meters away from the receiving antenna, which is mounted on a antenna tower. The antenna can be moved up and down between 1 meter and 4 meters to find out the maximum emission level. Broadband antenna (calibrated bilog antenna) is used as receiving antenna. Both horizontal and vertical polarization of the antenna is set on Test. In order to find the maximum emission levels, all of the interface cables must be manipulated according to ANSI C63.4-2003 on radiated emission Test.

This exploratory test was performed with EUT in X, Y, Z position and the worse case was found when EUT in X position.

The bandwidth of the EMI test receiver is set at 120kHz for frequency range from 30MHz to 1000 MHz

The bandwidth of the Spectrum Analyzer's RBW is set at 1MHz and VBW is set at 3MHz for peak emissions measurement above 1GHz, and 1MHz RBW, 10Hz VBW for average measurement above 1GHz.

4.6. Radiated Emission Test Results

PASS.

All the emissions from 30MHz to 25GHz were comply with the 15.209 Limit.

EST Technology

San Tun Management Zone, Houjie Town,
 Dongguan City, Guangdong, China
 Tel: +86-769-83081888
 Fax: +86-769-83081878

Data: 14 File: D:\test data\2011\10\Doking.EMI (50)

Date: 2011-12-09 Time: 13:17:52

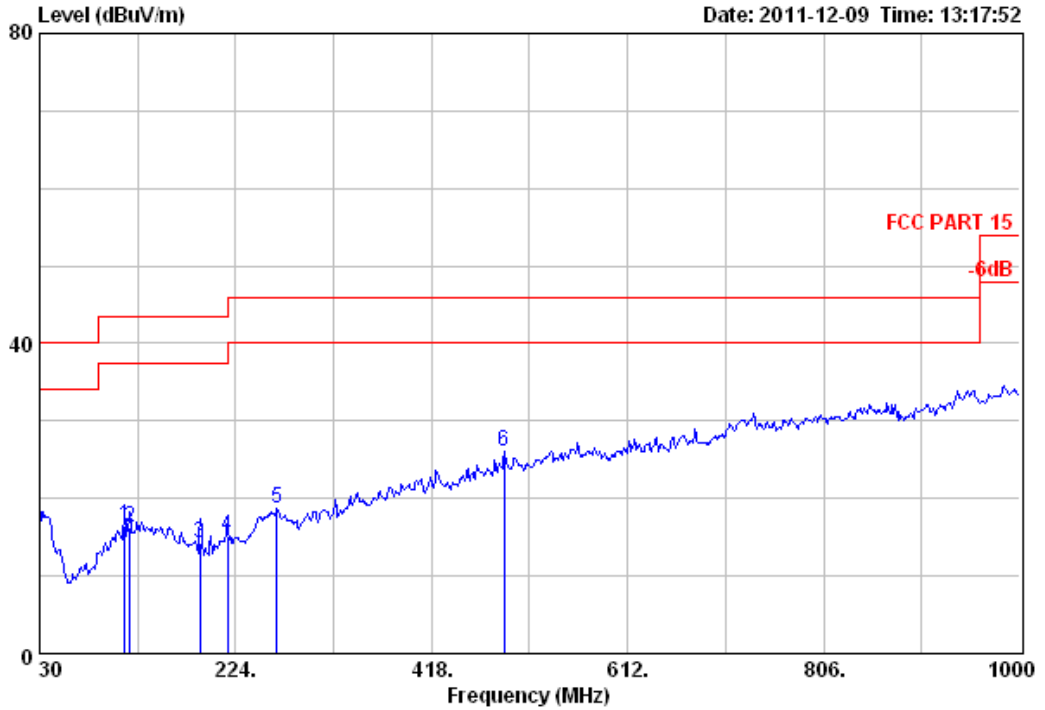

Site no. : 3m Chamber Data no. : 14
 Dis. / Ant. : 3m 27137 Ant. pol. : HORIZONTAL
 Limit : FCC PART 15
 Env. / Ins. : Temp:25.6'; Humi:56%; Press:101.52kPa
 Engineer : Tony
 EUT : 2.4G Wireless Mouse
 Power : DC 3V
 M/N : DOK-M159W
 Test Mode : TX 2402MHz

	Freq. (MHz)	Ant. Factor (dB/m)	Cable Loss (dB)	Reading (dBUV)	Emission Level (dBUV/m)	Limits (dBUV/m)	Margin (dB)	Remark (dB)
1	114.39	10.85	3.15	2.40	16.40	43.50	27.10	QP
2	119.24	11.11	3.22	1.97	16.30	43.50	27.20	QP
3	189.08	8.05	4.04	2.25	14.34	43.50	29.16	QP
4	216.24	8.80	4.42	1.84	15.06	46.00	30.94	QP
5	264.74	12.94	4.96	0.72	18.62	46.00	27.38	QP
6	489.78	17.81	6.89	1.46	26.16	46.00	19.84	QP

EST Technology

San Tun Management Zone, Houjie Town,
Dongguan City, Guangdong, China
Tel: +86-769-83081888
Fax: +86-769-83081878

Data: 15 File: D:\test data\2011\D\Doking.EMI (50) Date: 2011-12-09 Time: 13:18:15

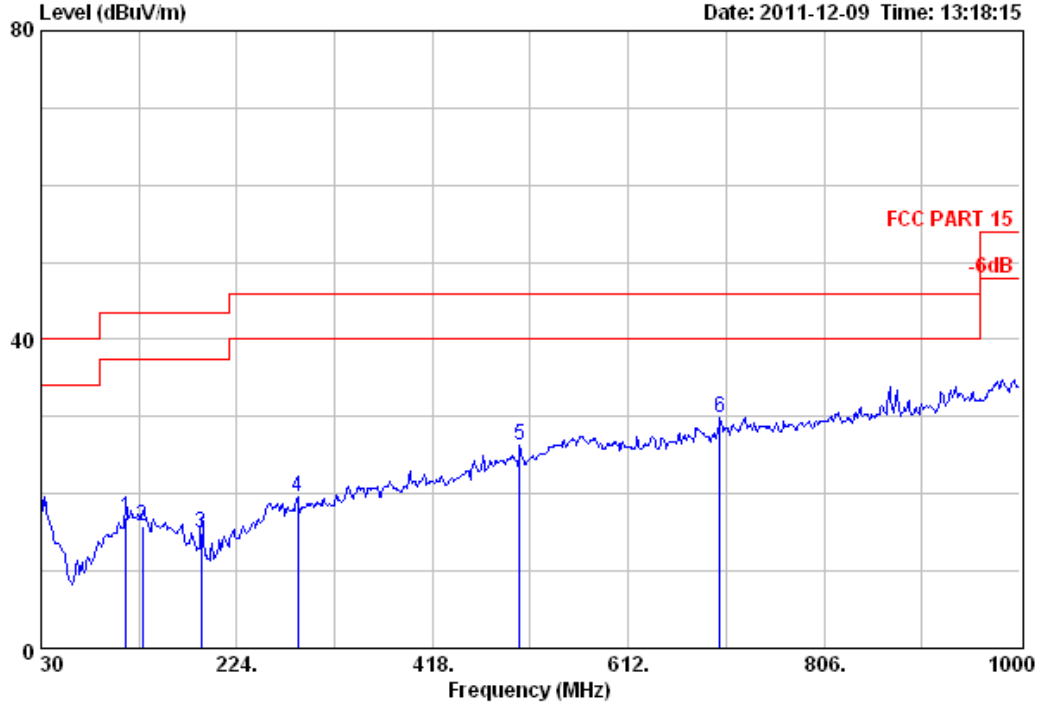

Site no. : 3m Chamber Data no. : 15
 Dis. / Ant. : 3m 27137 Ant. pol. : HORIZONTAL
 Limit : FCC PART 15
 Env. / Ins. : Temp:25.6'; Humi:56%; Press:101.52kPa
 Engineer : Tony
 EUT : 2.4G Wireless Mouse
 Power : DC 3V
 M/N : DOK-M159W
 Test Mode : TX 2442MHz

	Ant. Cable			Emission				Remark
	Freq. (MHz)	Factor (dB/m)	Loss (dB)	Reading (dBuV)	Level (dBuV/m)	Limits (dBuV/m)	Margin (dB)	
1	114.39	10.85	3.15	2.83	16.83	43.50	26.67	QP
2	130.88	11.33	3.36	1.22	15.91	43.50	27.59	QP
3	189.08	8.05	4.04	2.75	14.84	43.50	28.66	QP
4	284.14	12.52	5.14	2.00	19.66	46.00	26.34	QP
5	504.33	17.90	7.00	1.38	26.28	46.00	19.72	QP
6	703.18	20.71	8.41	0.66	29.78	46.00	16.22	QP

EST Technology

San Tun Management Zone, Houjie Town,
 Dongguan City, Guangdong, China
 Tel: +86-769-83081888
 Fax: +86-769-83081878

Data: 16 File: D:\test data\2011\1D\Doking.EMI (50)

Date: 2011-12-09 Time: 13:18:43

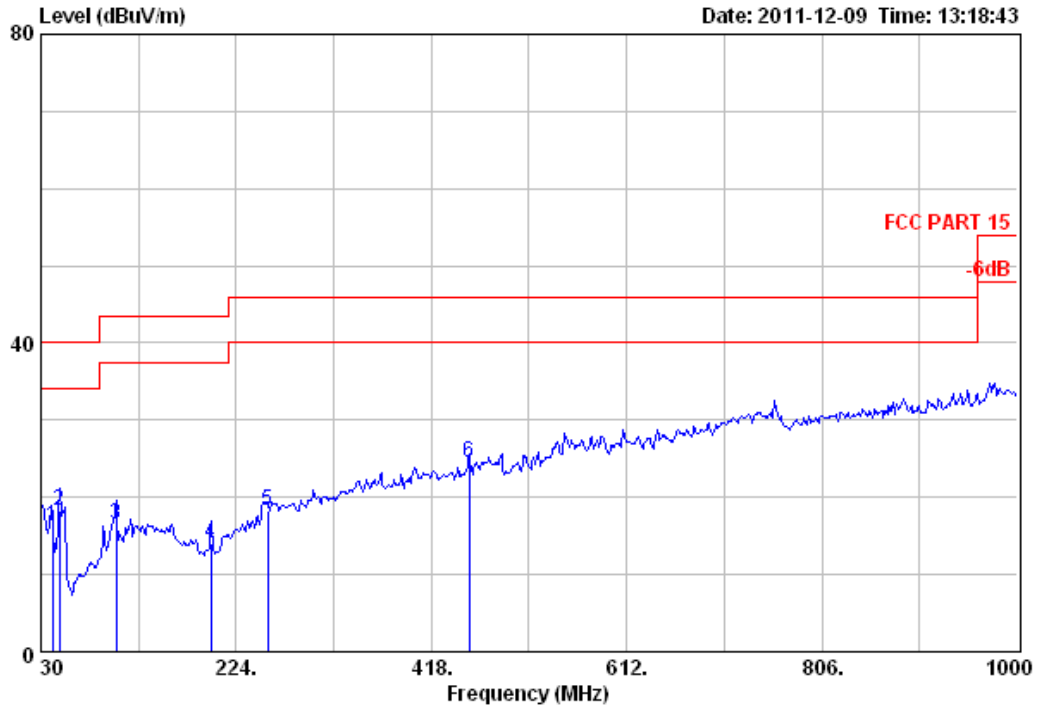

```

Site no.      : 3m Chamber                Data no. : 16
Dis. / Ant.  : 3m 27137                  Ant. pol. : VERTICAL
Limit        : FCC PART 15
Env. / Ins.  : Temp:25.6';Humi:56%;Press:101.52kPa
Engineer     : Tony
EUT          : 2.4G Wireless Mouse
Power        : DC 3V
M/N          : DOK-M159W
Test Mode    : TX 2442MHz
    
```

	Freq. (MHz)	Ant. Factor (dB/m)	Cable Loss (dB)	Reading (dBUV)	Emission Level (dBUV/m)	Limits (dBUV/m)	Margin (dB)	Remark (dB)
1	41.64	11.75	1.75	2.78	16.28	40.00	23.72	QP
2	48.43	8.37	1.95	7.88	18.20	40.00	21.80	QP
3	104.69	9.95	3.03	3.54	16.52	43.50	26.98	QP
4	198.78	7.71	4.17	2.08	13.96	43.50	29.54	QP
5	255.04	12.41	4.87	1.07	18.35	46.00	27.65	QP
6	455.83	16.69	6.65	1.26	24.60	46.00	21.40	QP

EST Technology

San Tun Management Zone, Houjie Town,
Dongguan City, Guangdong, China
Tel: +86-769-83081888
Fax: +86-769-83081878

Data: 17 File: D:\test data\2011\10\Doking.EMI (50)

Date: 2011-12-09 Time: 13:19:24

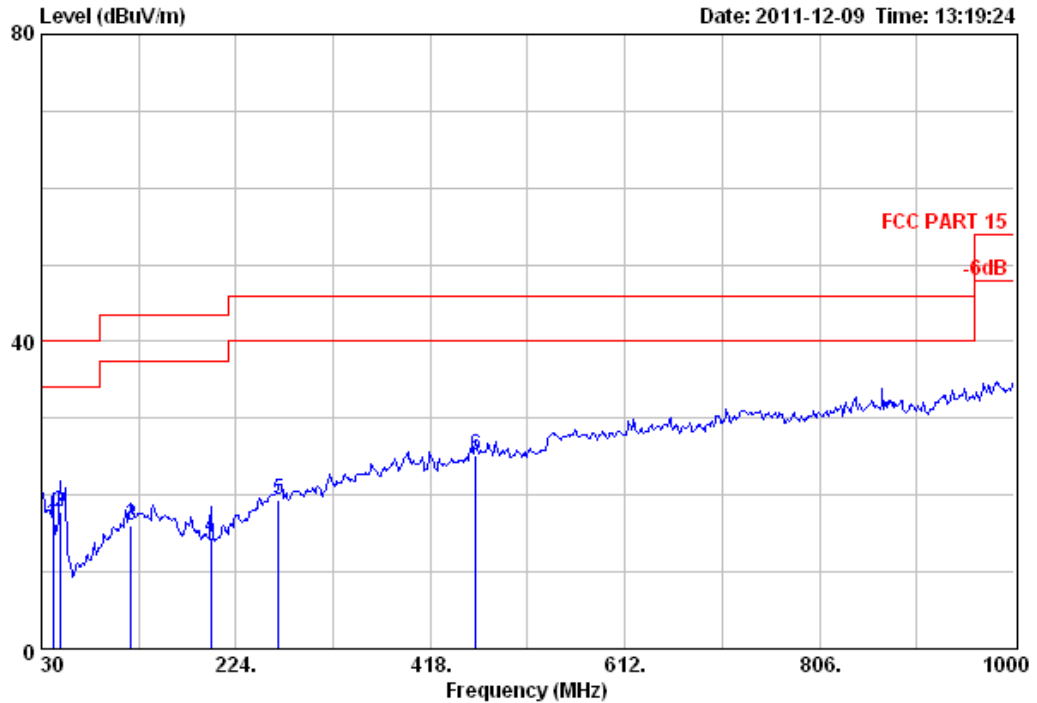

Site no. : 3m Chamber Data no. : 17
 Dis. / Ant. : 3m 27137 Ant. pol. : VERTICAL
 Limit : FCC PART 15
 Env. / Ins. : Temp:25.6';Humi:56%;Press:101.52kPa
 Engineer : Tony
 EUT : 2.4G Wireless Mouse
 Power : DC 3V
 M/N : DOK-M159W
 Test Mode : TX 2478MHz

	Freq. (MHz)	Ant. Factor (dB/m)	Cable Loss (dB)	Emission Reading (dBUV)	Level (dBUV/m)	Limits (dBUV/m)	Margin (dB)	Remark (dB)
1	41.64	11.75	1.75	2.81	16.31	40.00	23.69	QP
2	48.43	8.37	1.95	7.48	17.80	40.00	22.20	QP
3	119.24	11.11	3.22	1.67	16.00	43.50	27.50	QP
4	198.78	7.71	4.17	2.66	14.54	43.50	28.96	QP
5	266.68	12.79	4.97	1.72	19.48	46.00	26.52	QP
6	463.59	16.97	6.73	1.39	25.09	46.00	20.91	QP



EST Technology

San Tun Management Zone, Houjie Town,
 Dongguan City, Guangdong, China
 Tel: +86-769-83081888
 Fax: +86-769-83081878

Data: 18 File: D:\test data\2011\1D\Doking.EMI (50) Date: 2011-12-09 Time: 13:20:00

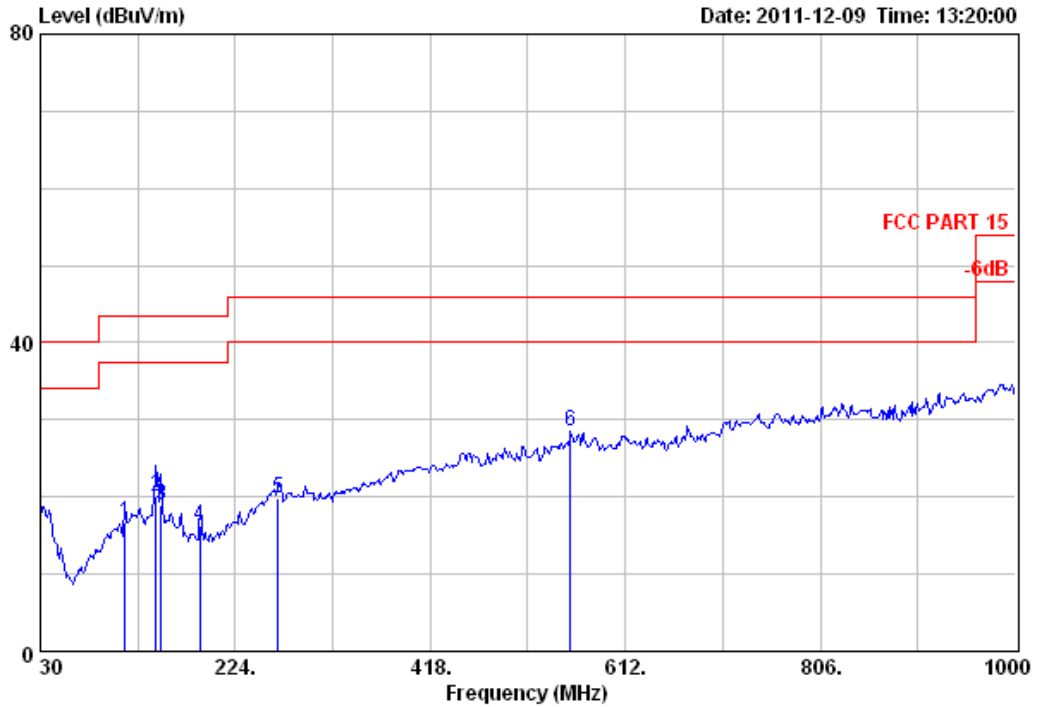

Site no. : 3m Chamber Data no. : 18
 Dis. / Ant. : 3m 27137 Ant. pol. : HORIZONTAL
 Limit : FCC PART 15
 Env. / Ins. : Temp:25.6';Humi:56%;Press:101.52kPa
 Engineer : Tony
 EUT : 2.4G Wireless Mouse
 Power : DC 3V
 M/N : DOK-M159W
 Test Mode : TX 2478MHz

	Freq. (MHz)	Ant. Factor (dB/m)	Cable Loss (dB)	Reading (dBuV)	Emission Level (dBuV/m)	Limits (dBuV/m)	Margin (dB)	Remark (dB)
1	114.39	10.85	3.15	2.82	16.82	43.50	26.68	QP
2	145.43	11.22	3.56	5.21	19.99	43.50	23.51	QP
3	150.28	10.86	3.62	4.42	18.90	43.50	24.60	QP
4	189.08	8.05	4.04	4.12	16.21	43.50	27.29	QP
5	266.68	12.79	4.97	2.05	19.81	46.00	26.19	QP
6	557.68	19.66	7.40	1.36	28.42	46.00	17.58	QP

Emissions from 1GHz to 18GHz

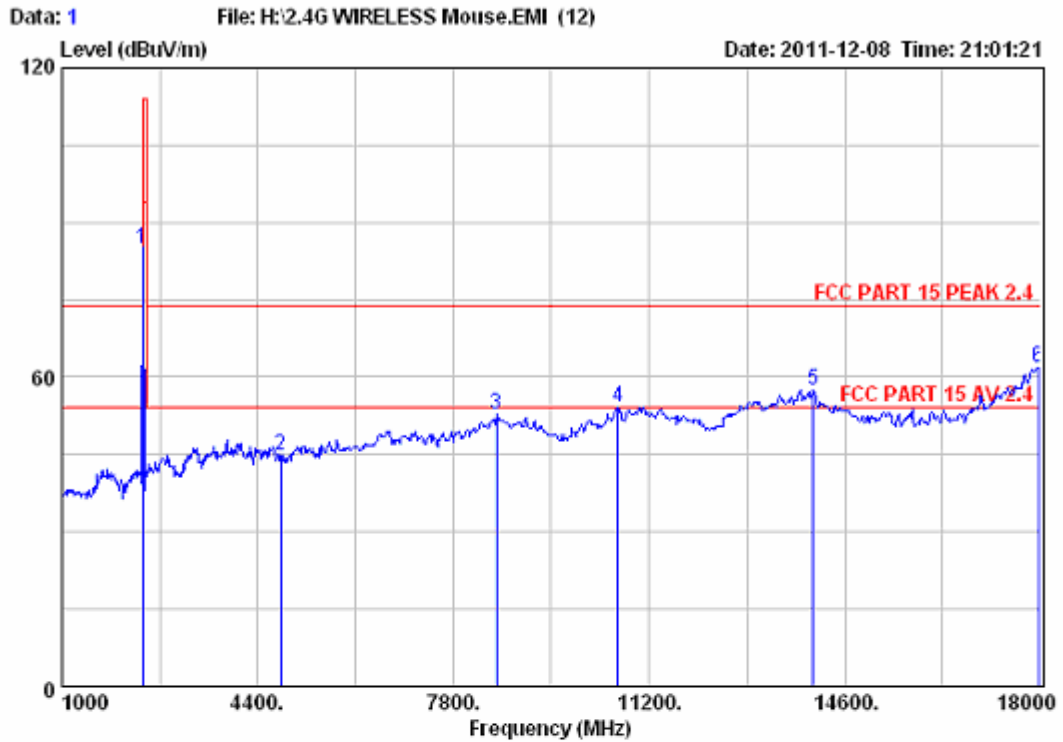

Site no. : 3m Chamber Data no. : 1
 Dis. / Ant. : 3m 3115 FACTOR Ant. pol. : HORIZONTAL
 Limit : FCC PART 15 PEAK 2.4
 Env. / Ins. : 8593EM 24*C/51%
 Engineer : Tony
 EUT : 2.4G Wireless Mouse
 Power : DC 3V
 M/N : DOK-M159W
 Test Mode : TX 2402MHz

Emission					
Freq. (MHz)	Level (dBuV/m)	Limits (dBuV/m)	Margin (dB)	Remark (dB)	
1	2402.00	84.85	114.00	29.15	Peak
2	4804.00	44.94	74.00	29.06	Peak
3	8548.00	52.97	74.00	21.03	Peak
4	10656.00	54.26	74.00	19.74	Peak
5	14056.00	57.51	74.00	16.49	Peak
6	17966.00	61.94	74.00	12.06	Peak

Remarks: Emission Level = Antenna Factor + Cable Loss + Reading - AMP Factor

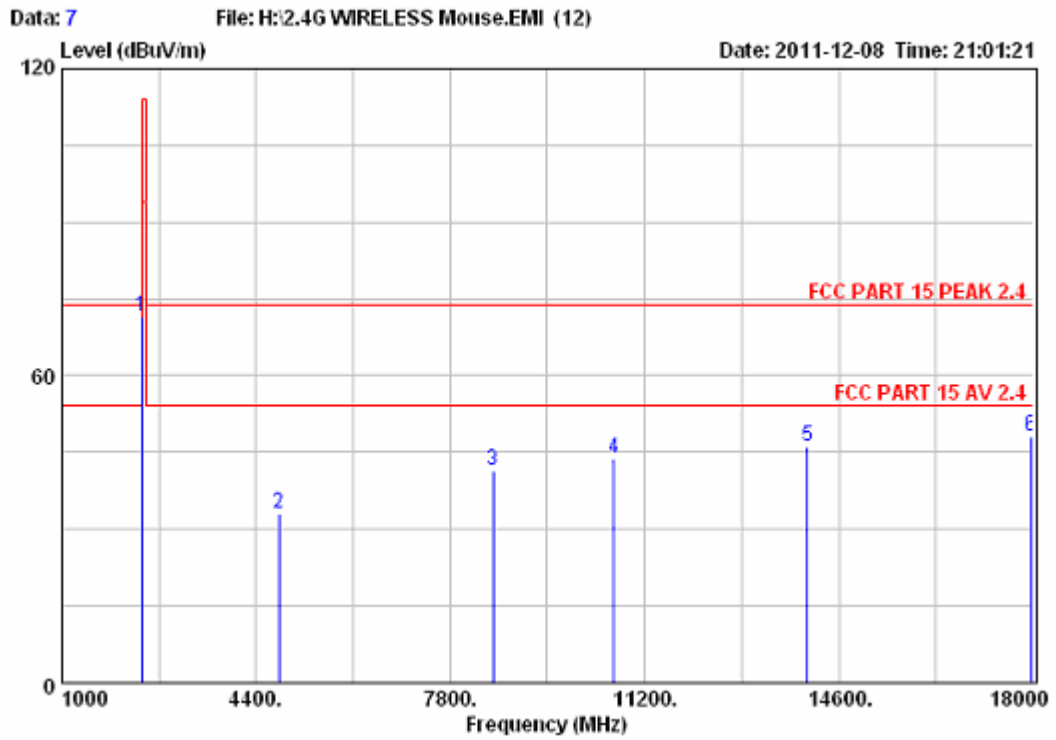

Data: 7 File: H:\2.4G WIRELESS Mouse.EMI (12) Date: 2011-12-08 Time: 21:01:21
 Site no. : 3m Chamber Data no. : 7
 Dis. / Ant. : 3m 3115 FACTOR Ant. pol. : HORIZONTAL
 Limit : FCC PART 15 PEAK 2.4
 Env. / Ins. : 8593EM 24°C/51%
 Engineer : Tony
 EUT : 2.4G Wireless Mouse
 Power : DC 3V
 H/N : DOK-M159W
 Test Mode : TX 2402MHz

	Emission				
	Freq. (MHz)	Level (dBuV/m)	Limits (dBuV/m)	Margin (dB)	Remark (dB)
1	2402.00	71.61	94.00	22.39	Average
2	4804.00	33.06	54.00	20.94	Average
3	8548.00	41.50	54.00	12.50	Average
4	10656.00	43.72	54.00	10.28	Average
5	14056.00	46.13	54.00	7.87	Average
6	17966.00	48.15	54.00	5.85	Average

Remarks: Emission Level = Antenna Factor + Cable Loss + Reading - AMP Factor

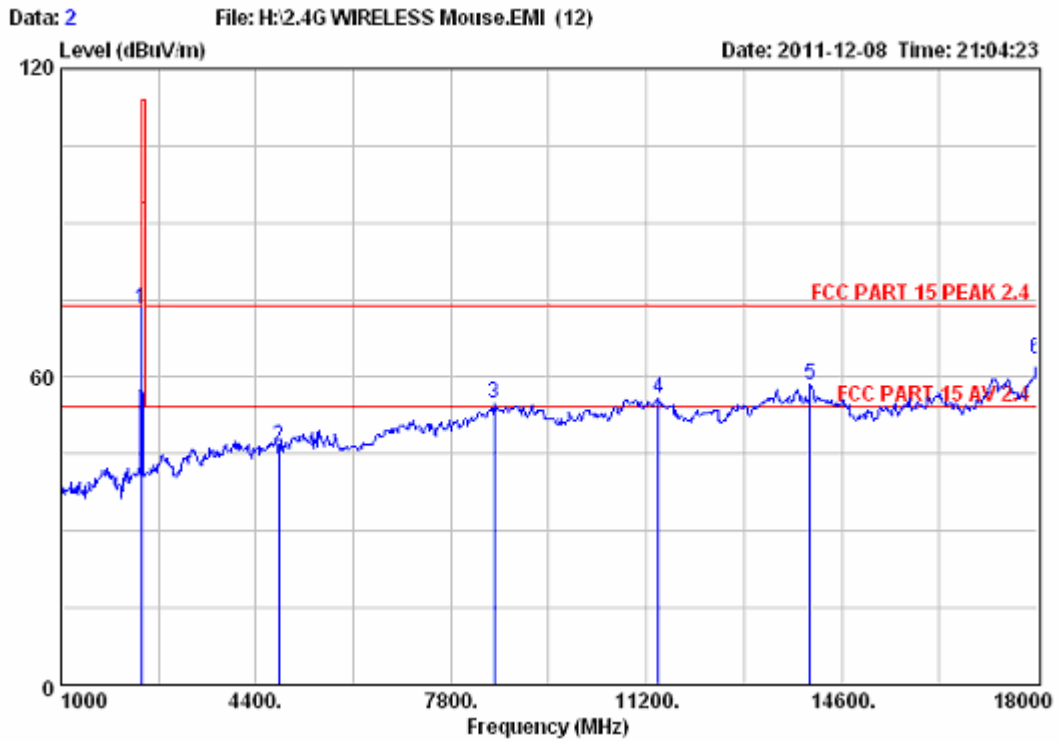

Site no. : 3m Chamber Data no. : 2
 Dis. / Ant. : 3m 3115 FACTOR Ant. pol. : VERTICAL
 Limit : FCC PART 15 PEAK 2.4
 Env. / Ins. : 8593EM 24*C/51%
 Engineer : Tony
 EUT : 2.4G Wireless Mouse
 Power : DC 3V
 M/N : DOK-M159W
 Test Mode : TX 2402MHz

Emission					
Peak	Freq. (MHz)	Level (dBuV/m)	Limits (dBuV/m)	Margin (dB)	Remark (dB)
1	2402.00	73.11	114.00	40.89	Peak
2	4804.00	46.36	74.00	27.64	Peak
3	8548.00	54.97	74.00	19.03	Peak
4	11404.00	55.73	74.00	18.27	Peak
5	14056.00	58.51	74.00	15.49	Peak
6	18000.00	63.66	74.00	10.34	Peak

Remarks: Emission Level = Antenna Factor + Cable Loss + Reading - AMP Factor

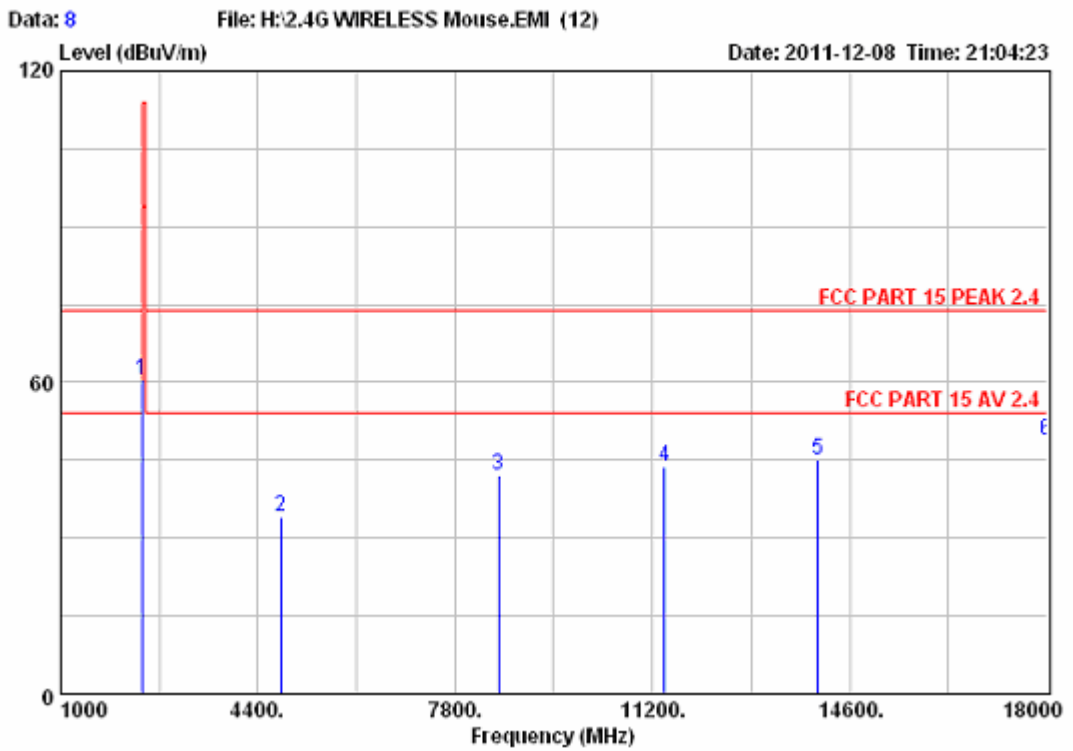

Site no. : 3m Chamber Data no. : 8
 Dis. / Ant. : 3m 3115 FACTOR Ant. pol. : VERTICAL
 Limit : FCC PART 15 PEAK 2.4
 Env. / Ins. : 8593EM 24°C/51%
 Engineer : Tony
 EUT : 2.4G Wireless Mouse
 Power : DC 3V
 M/N : DOK-M159W
 Test Mode : TX 2402MHz

	Emission				
Freq. (MHz)	Level (dBUV/m)	Limits (dBUV/m)	Margin (dB)	Remark (dB)	
1	2402.00	60.52	94.00	33.48	Average
2	4804.00	34.22	54.00	19.78	Average
3	8548.00	42.20	54.00	11.80	Average
4	11404.00	43.93	54.00	10.07	Average
5	14056.00	45.16	54.00	8.84	Average
6	18000.00	48.71	54.00	5.29	Average

Remarks: Emission Level = Antenna Factor + Cable Loss + Reading - AMP Factor

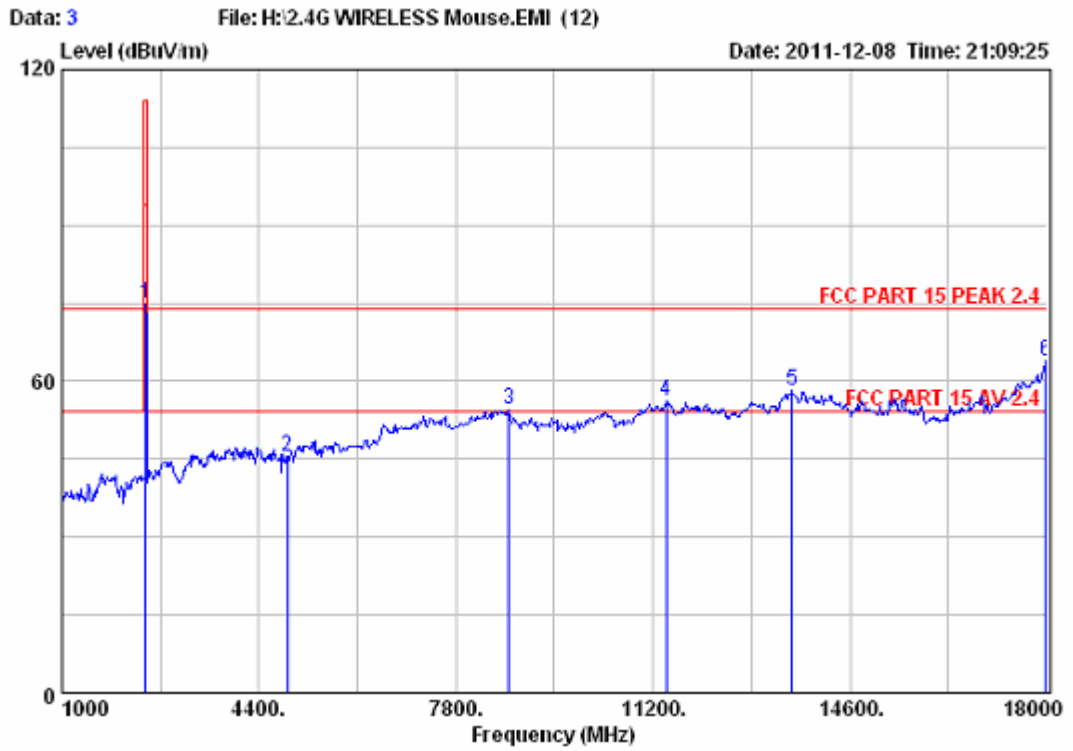

Site no. : 3m Chamber Data no. : 3
 Dis. / Ant. : 3m 3115 FACTOR Ant. pol. : VERTICAL
 Limit : FCC PART 15 PEAK 2.4
 Env. / Ins. : 8593EM 24*C/51%
 Engineer : Tony
 EUT : 2.4G Wireless Mouse
 Power : DC 3V
 M/N : DOK-M159W
 Test Mode : TX 2442MHz

Emission					
	Freq.	Level	Limits	Margin	Remark
	(MHz)	(dBuV/m)	(dBuV/m)	(dB)	(dB)
1	2442.00	74.88	114.00	39.12	Peak
2	4884.00	45.52	74.00	28.48	Peak
3	8718.00	54.46	74.00	19.54	Peak
4	11421.00	56.14	74.00	17.86	Peak
5	13597.00	58.01	74.00	15.99	Peak
6	17983.00	63.72	74.00	10.28	Peak

Remarks: Emission Level = Antenna Factor + Cable Loss + Reading - AMP Factor

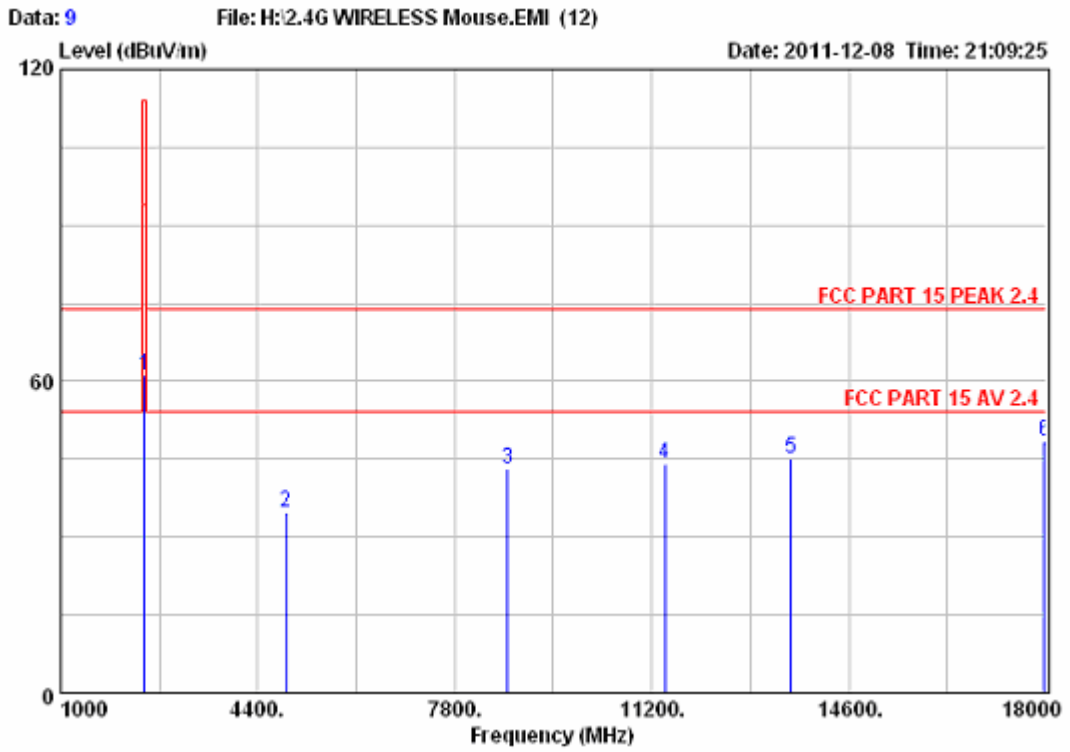

Site no. : 3m Chamber Data no. : 9
 Dis. / Ant. : 3m 3115 FACTOR Ant. pol. : VERTICAL
 Limit : FCC PART 15 PEAK 2.4
 Env. / Ins. : 8593EM 24°C/51%
 Engineer : Tony
 EUT : 2.4G Wireless Mouse
 Power : DC 3V
 M/N : DOK-M159W
 Test Mode : TX 2442MHz

Emission					
	Freq. (MHz)	Level (dBuV/m)	Limits (dBuV/m)	Margin (dB)	Remark (dB)
1	2442.00	61.33	94.00	32.67	Average
2	4884.00	34.72	54.00	19.28	Average
3	8718.00	43.05	54.00	10.95	Average
4	11421.00	44.08	54.00	9.92	Average
5	13597.00	45.18	54.00	8.82	Average
6	17983.00	48.52	54.00	5.48	Average

Remarks: Emission Level = Antenna Factor + Cable Loss + Reading - AMP Factor

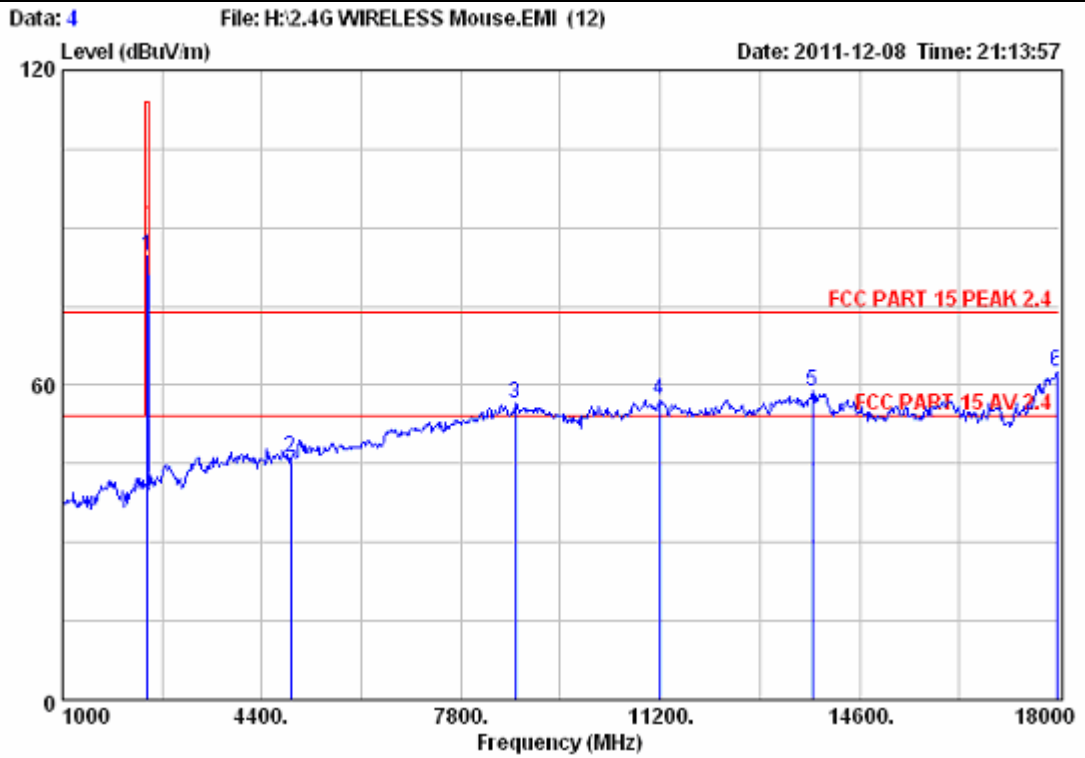

Site no. : 3m Chamber Data no. : 4
 Dis. / Ant. : 3m 3115 FACTOR Ant. pol. : HORIZONTAL
 Limit : FCC PART 15 PEAK 2.4
 Env. / Ins. : 8593EM 24*C/51%
 Engineer : Tony
 EUT : 2.4G Wireless Mouse
 Power : DC 3V
 M/N : DOK-M159W
 Test Mode : TX 2442MHz

Emission					
	Freq.	Level	Limits	Margin	Remark
	(MHz)	(dBuV/m)	(dBuV/m)	(dB)	(dB)
1	2442.00	84.70	114.00	29.30	Peak
2	4884.00	46.29	74.00	27.71	Peak
3	8735.00	56.42	74.00	17.58	Peak
4	11183.00	57.12	74.00	16.88	Peak
5	13801.00	58.68	74.00	15.32	Peak
6	17966.00	62.52	74.00	11.48	Peak

Remarks: Emission Level = Antenna Factor + Cable Loss + Reading — AMP Factor

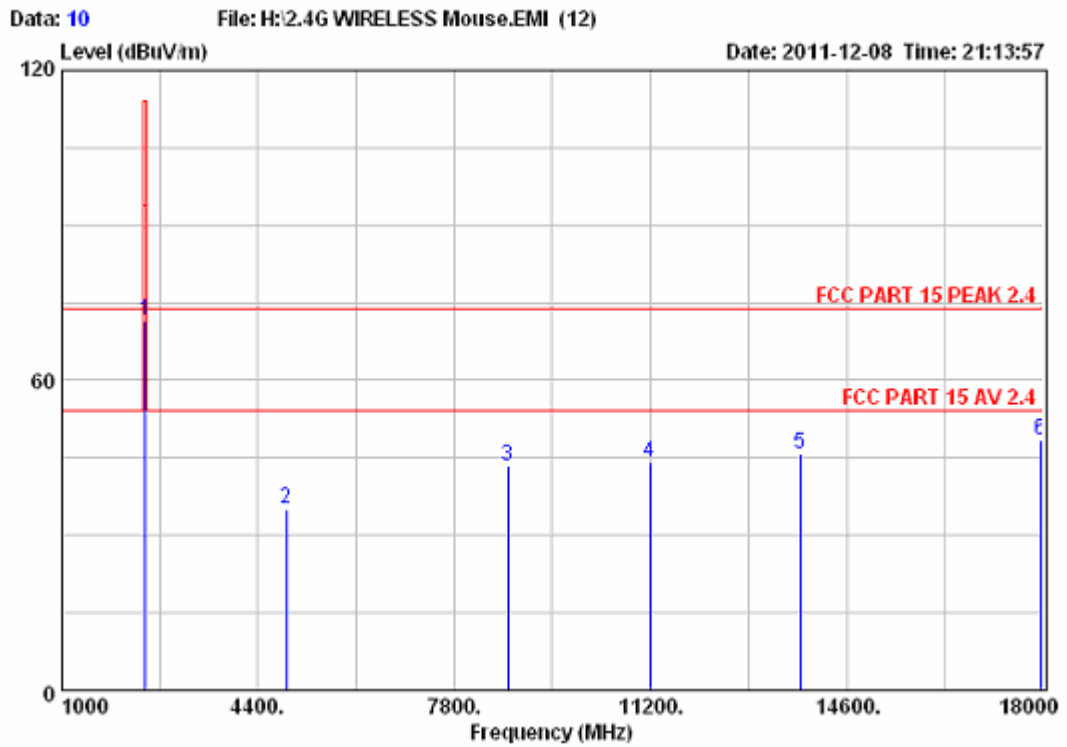

Site no. : 3m Chamber
 Dis. / Ant. : 3m 3115 FACTOR
 Limit : FCC PART 15 PEAK 2.4
 Env. / Ins. : 8593EM 24°C/51%
 Engineer : Tony
 EUT : 2.4G Wireless Mouse
 Power : DC 3V
 M/N : DOK-M159W
 Test Mode : TX 2442MHz
 Data no. : 10
 Ant. pol. : HORIZONTAL

Emission					
	Freq. (MHz)	Level (dBUV/m)	Limits (dBUV/m)	Margin (dB)	Remark (dB)
1	2442.00	71.44	94.00	22.56	Average
2	4884.00	35.10	54.00	18.90	Average
3	8735.00	43.52	54.00	10.48	Average
4	11183.00	44.17	54.00	9.83	Average
5	13801.00	45.89	54.00	8.11	Average
6	17966.00	48.40	54.00	5.60	Average

Remarks: Emission Level = Antenna Factor + Cable Loss + Reading - AMP Factor

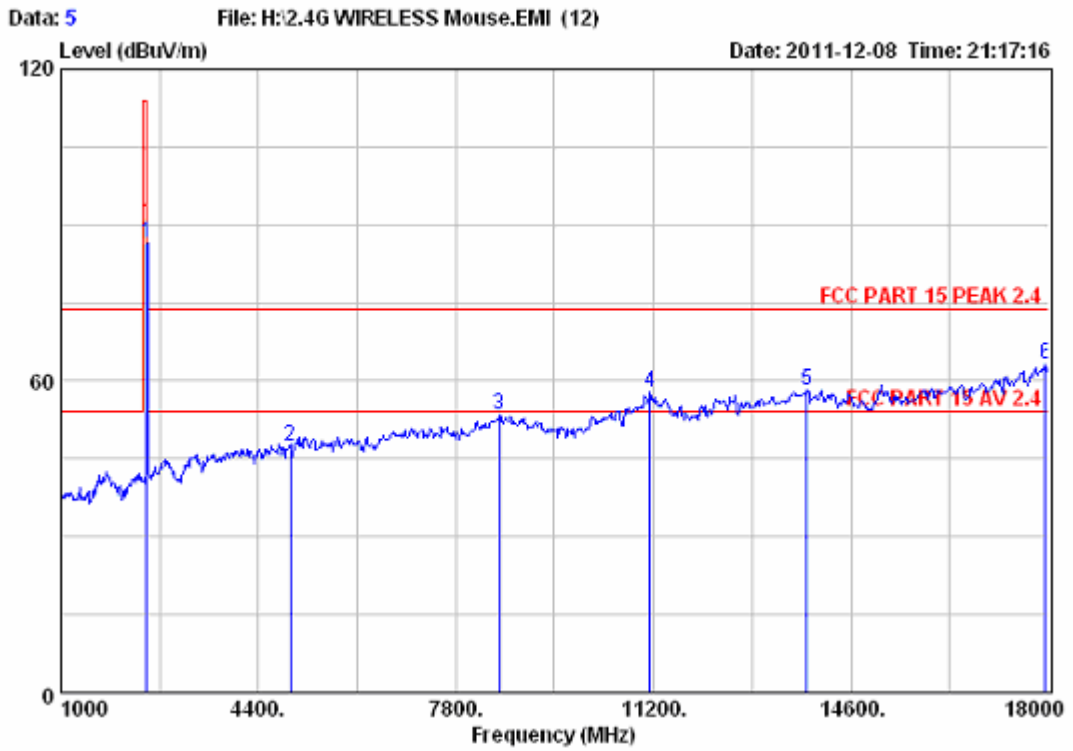

Site no. : 3m Chamber Data no. : 5
 Dis. / Ant. : 3m 3115 FACTOR Ant. pol. : HORIZONTAL
 Limit : FCC PART 15 PEAK 2.4
 Env. / Ins. : 8593EM 24°C/51%
 Engineer : Tony
 EUT : 2.4G Wireless Mouse
 Power : DC 3V
 M/N : DOK-M159W
 Test Mode : TX 2478MHz

Emission					
	Freq.	Level	Limits	Margin	Remark
	(MHz)	(dBUV/m)	(dBUV/m)	(dB)	(dB)
1	2478.00	86.61	114.00	27.39	Peak
2	4956.00	47.31	74.00	26.69	Peak
3	8548.00	53.38	74.00	20.62	Peak
4	11149.00	57.82	74.00	16.18	Peak
5	13835.00	58.21	74.00	15.79	Peak
6	17949.00	63.01	74.00	10.99	Peak

Remarks: Emission Level = Antenna Factor + Cable Loss + Reading — AMP Factor

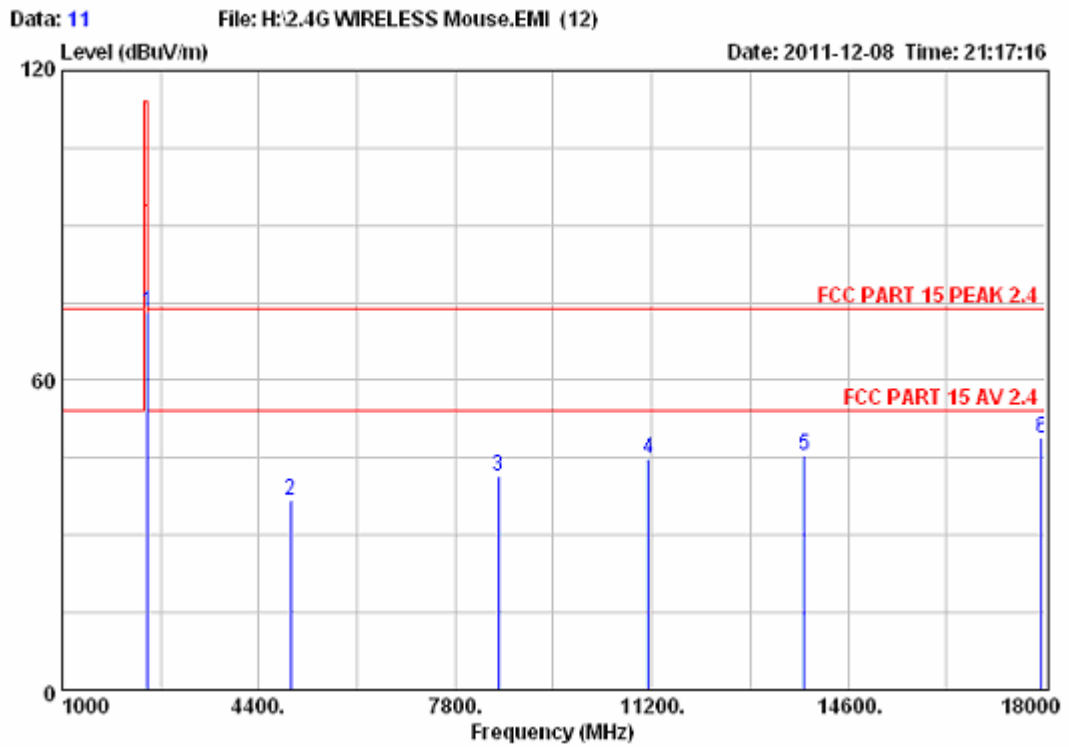

Site no. : 3m Chamber
 Dis. / Ant. : 3m 3115 FACTOR
 Limit : FCC PART 15 PEAK 2.4
 Env. / Ins. : 8593EM 24°C/51%
 Engineer : Tony
 EUT : 2.4G Wireless Mouse
 Power : DC 3V
 M/N : DOK-M159W
 Test Mode : TX 2478MHz
 Data no. : 11
 Ant. pol. : HORIZONTAL

Emission					
	Freq. (MHz)	Level (dBuV/m)	Limits (dBuV/m)	Margin (dB)	Remark (dB)
1	2478.00	73.10	94.00	20.90	Average
2	4956.00	36.90	54.00	17.10	Average
3	8548.00	41.55	54.00	12.45	Average
4	11149.00	44.75	54.00	9.25	Average
5	13835.00	45.61	54.00	8.39	Average
6	17949.00	48.93	54.00	5.07	Average

Remarks: Emission Level = Antenna Factor + Cable Loss + Reading — AMP Factor

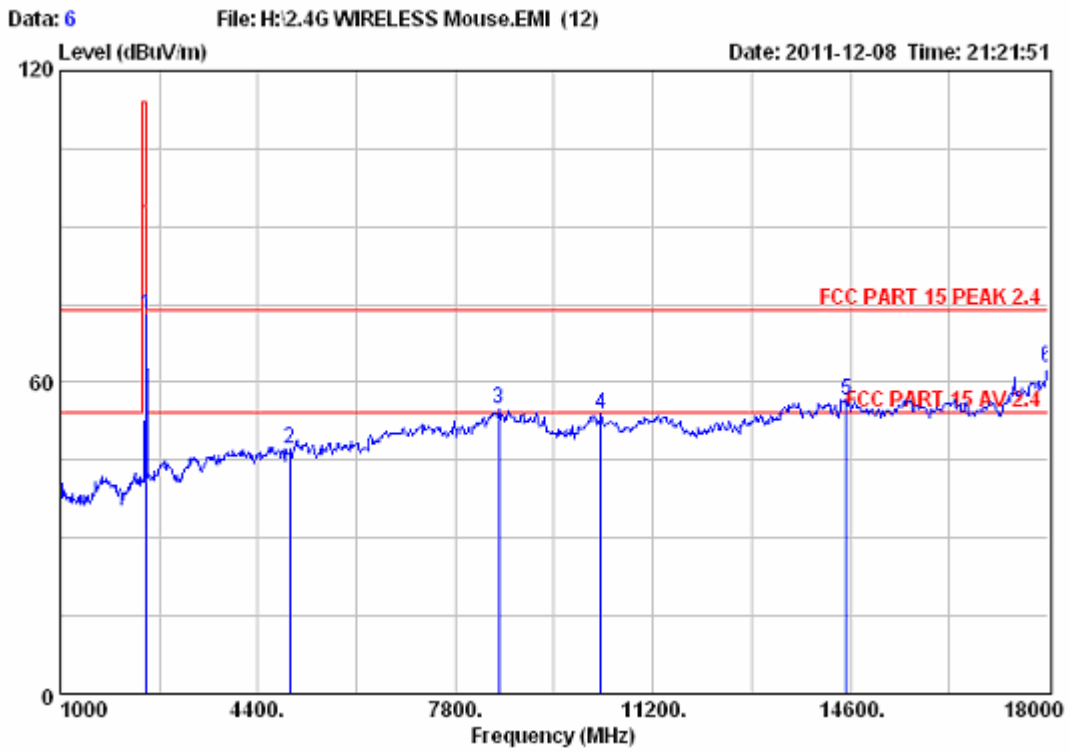

Site no. : 3m Chamber Data no. : 6
 Dis. / Ant. : 3m 3115 FACTOR Ant. pol. : VERTICAL
 Limit : FCC PART 15 PEAK 2.4
 Env. / Ins. : 8593EM 24°C/51%
 Engineer : Tony
 EUT : 2.4G Wireless Mouse
 Power : DC 3V
 M/N : DOK-M159W
 Test Mode : TX 2478MHz

	Freq. (MHz)	Emission Level (dBuV/m)	Limits (dBuV/m)	Margin (dB)	Remark (dB)
1	2478.00	72.87	114.00	41.13	Peak
2	4956.00	47.02	74.00	26.98	Peak
3	8548.00	54.92	74.00	19.08	Peak
4	10299.00	53.71	74.00	20.29	Peak
5	14532.00	56.42	74.00	17.58	Peak
6	18000.00	62.77	74.00	11.23	Peak

Remarks: Emission Level = Antenna Factor + Cable Loss + Reading - AMP Factor

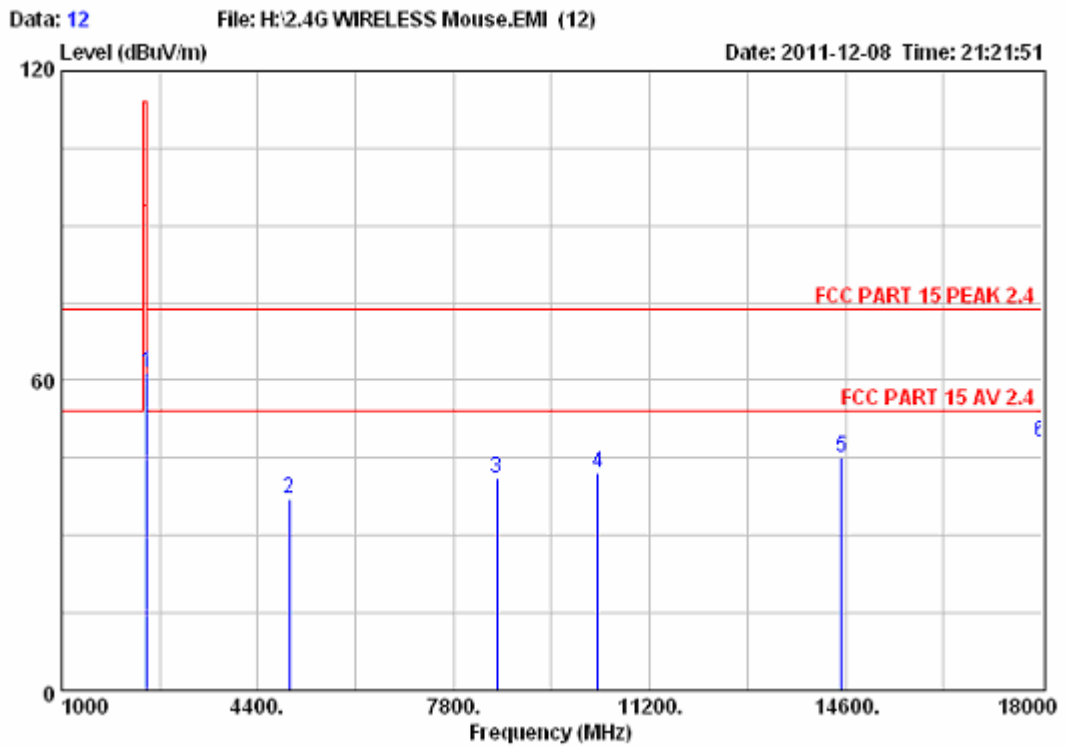

Site no. : 3m Chamber Data no. : 12
 Dis. / Ant. : 3m 3115 FACTOR Ant. pol. : VERTICAL
 Limit : FCC PART 15 PEAK 2.4
 Env. / Ins. : 8593EM 24°C/51%
 Engineer : Tony
 EUT : 2.4G Wireless Mouse
 Power : DC 3V
 H/N : DOK-M159W
 Test Mode : TX 2478MHz

	Emission				
	Freq. (MHz)	Level (dBuV/m)	Limits (dBuV/m)	Margin (dB)	Remark (dB)
1	2478.00	61.61	94.00	32.39	Average
2	4956.00	37.17	54.00	16.83	Average
3	8548.00	41.12	54.00	12.88	Average
4	10299.00	42.06	54.00	11.94	Average
5	14532.00	45.10	54.00	8.90	Average
6	18000.00	48.26	54.00	5.74	Average

Remarks: Emission Level = Antenna Factor + Cable Loss + Reading - AMP Factor

Emissions from 18GHz to 24GHz

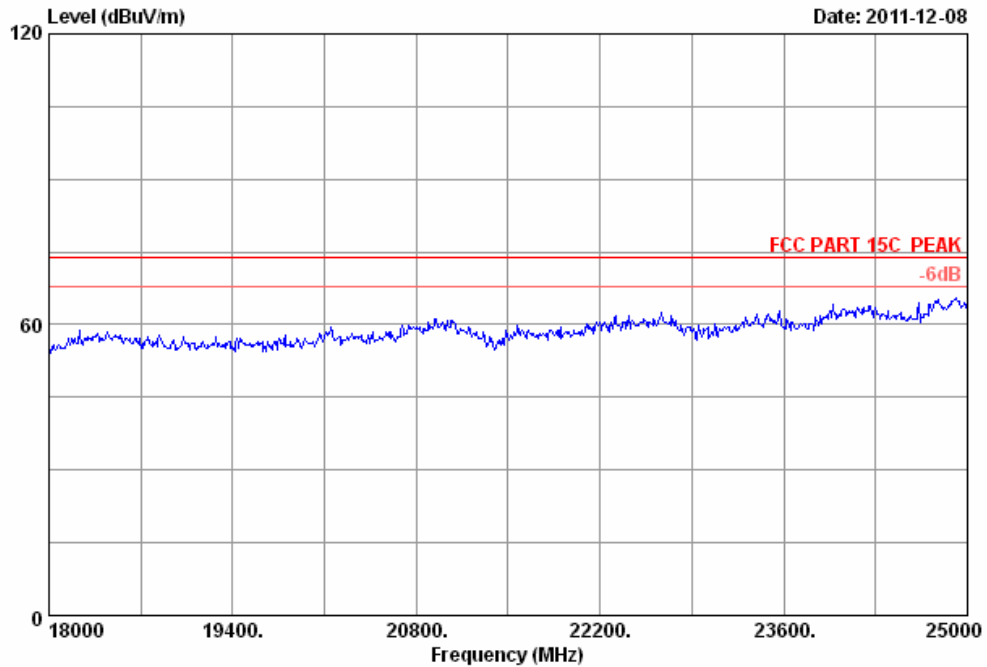

Site no. : 3m Chamber Data no. : 13
Dis. / Ant. : 3m 3115 FACTOR Ant. pol. : HORIZONTAL
Limit : FCC PART 15 PEAK 2.4
Env. / Ins. : 8593EM 24*C/51%
Engineer : Tony
EUT : 2.4G Wireless Mouse
Power : DC 3V
M/N : DOK-M159W
Test Mode : TX 2402MHz

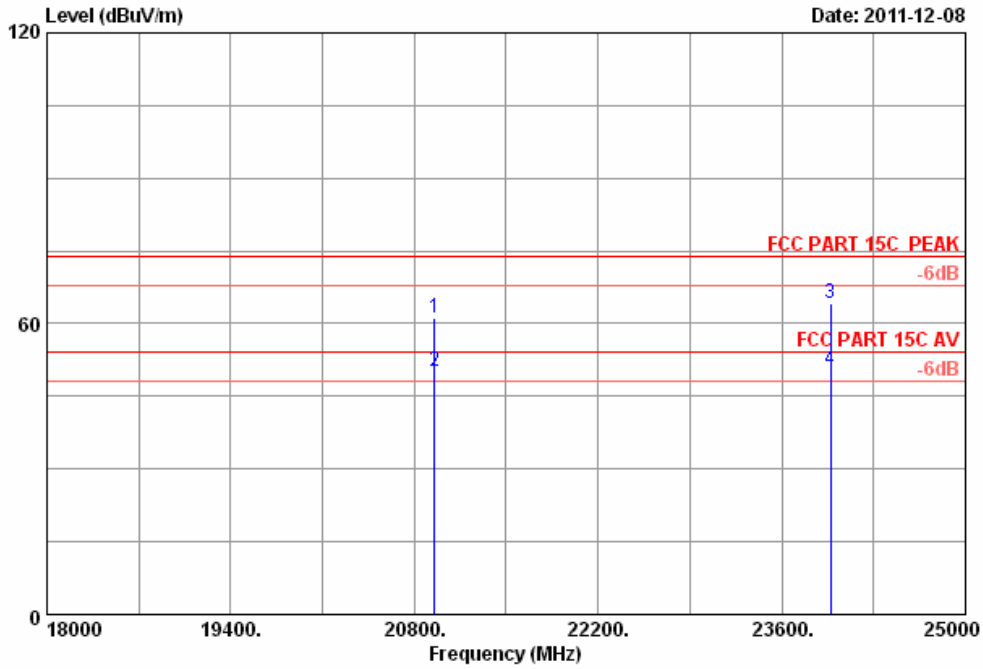

Site no. : 3m Chamber Data no. : 14
 Dis. / Ant. : 3m 3115 FACTOR Ant. pol. : HORIZONTAL
 Limit : FCC PART 15 PEAK 2.4
 Env. / Ins. : 8593EM 24*C/51%
 Engineer : Tony
 EUT : 2.4G Wireless Mouse
 Power : DC 3V
 M/N : DOK-M159W
 Test Mode : TX 2402MHz

Emission				
Freq. (MHz)	Level (dBuV/m)	Limits (dBuV/m)	Margin (dB)	Remark
1 20954.000	61.26	74.00	12.74	Peak
2 20954.000	50.08	54.00	3.92	Average
3 23971.000	64.08	74.00	9.92	Peak
4 23971.000	50.58	54.00	3.42	Average

Remarks: Emission Level = Antenna Factor + Cable Loss + Reading - AMP Factor

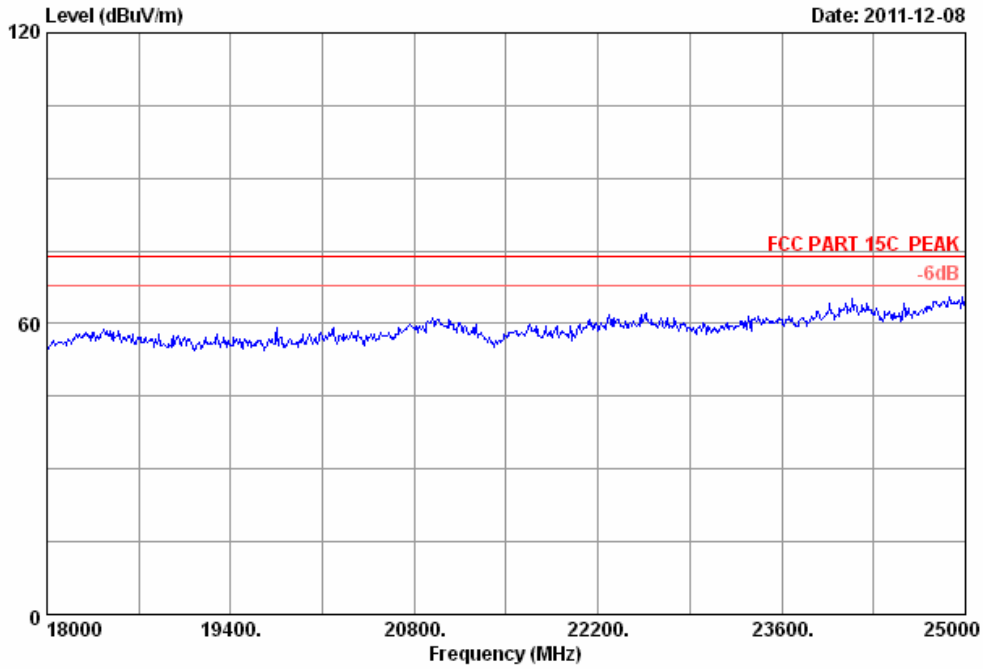

Site no. : 3m Chamber Data no. : 15
Dis. / Ant. : 3m 3115 FACTOR Ant. pol. : VERTICAL
Limit : FCC PART 15 PEAK 2.4
Env. / Ins. : 8593EM 24*C/51%
Engineer : Tony
EUT : 2.4G Wireless Mouse
Power : DC 3V
M/N : DOK-M159W
Test Mode : TX 2402MHz

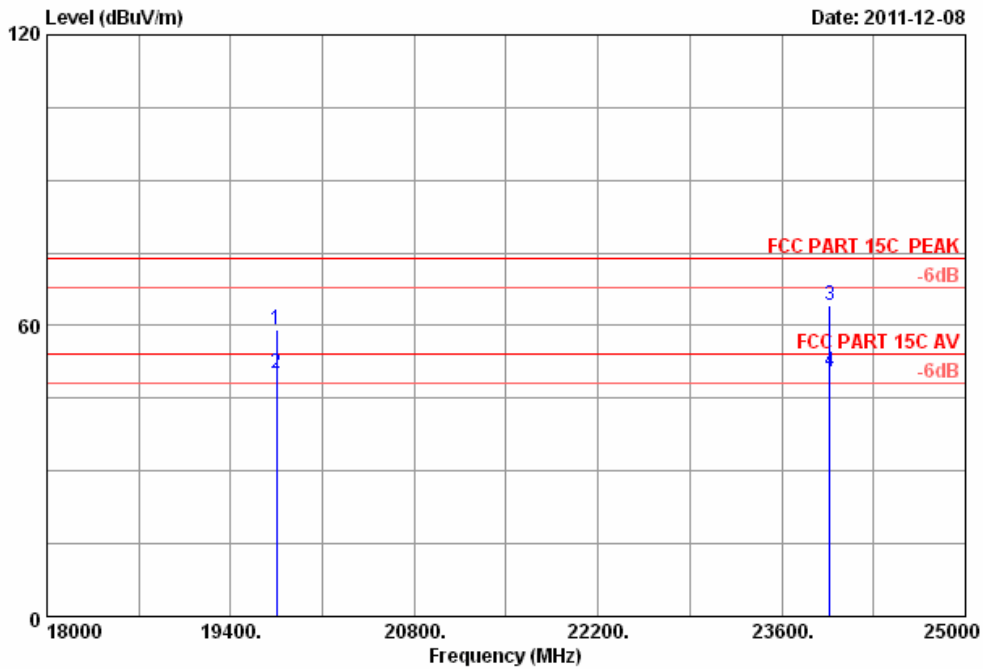

Site no. : 3m Chamber Data no. : 16
 Dis. / Ant. : 3m 3115 FACTOR Ant. pol. : VERTICAL
 Limit : FCC PART 15 PEAK 2.4
 Env. / Ins. : 8593EM 24*C/51%
 Engineer : Tony
 EUT : 2.4G Wireless Mouse
 Power : DC 3V
 M/N : DOK-M159W
 Test Mode : TX 2402MHz

Emission				
Freq. (MHz)	Level (dBuV/m)	Limits (dBuV/m)	Margin (dB)	Remark
1 19750.000	59.09	74.00	14.91	Peak
2 19750.000	50.03	54.00	3.97	Average
3 23964.000	64.26	74.00	9.74	Peak
4 23964.000	50.51	54.00	3.49	Average

Remarks: Emission Level = Antenna Factor + Cable Loss + Reading - AMP Factor

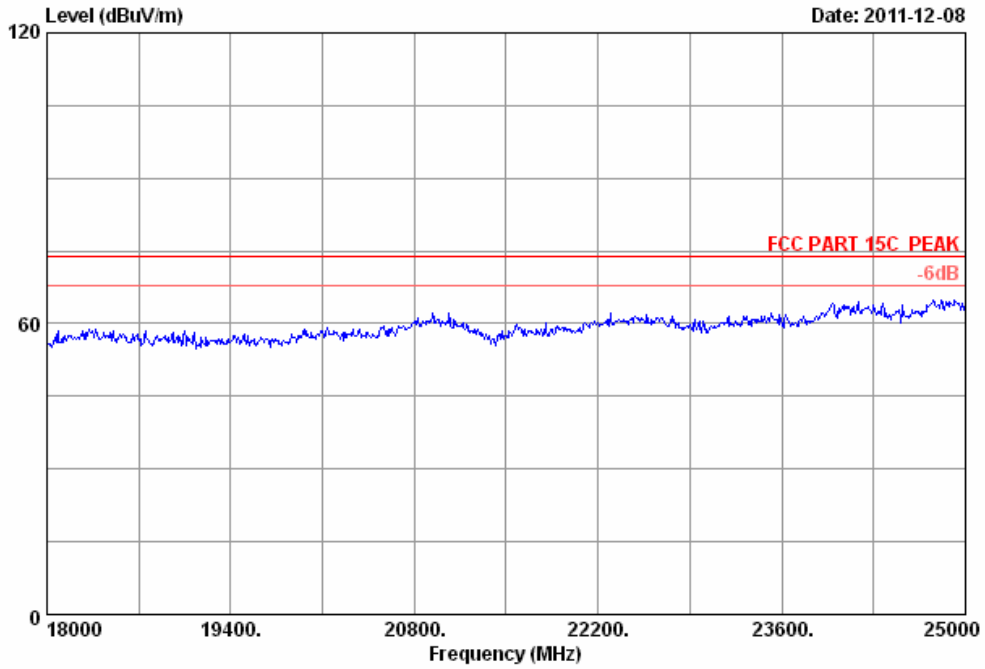

Site no. : 3m Chamber Data no. : 17
Dis. / Ant. : 3m 3115 FACTOR Ant. pol. : VERTICAL
Limit : FCC PART 15 PEAK 2.4
Env. / Ins. : 8593EM 24*C/51%
Engineer : Tony
EUT : 2.4G Wireless Mouse
Power : DC 3V
M/N : DOK-M159W
Test Mode : TX 2442MHz

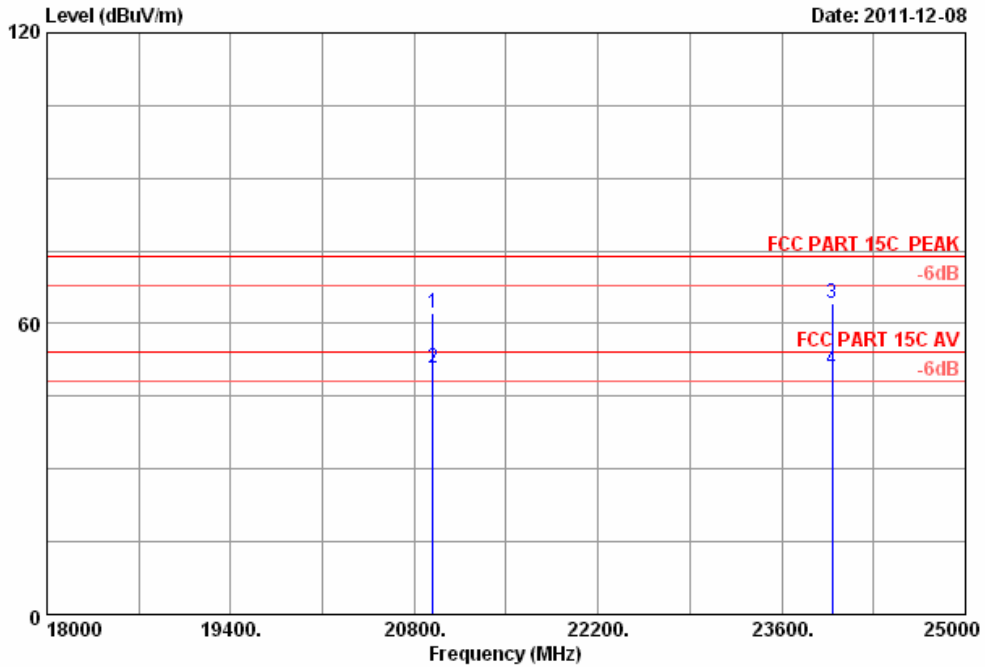

Site no. : 3m Chamber Data no. : 18
 Dis. / Ant. : 3m 3115 FACTOR Ant. pol. : VERTICAL
 Limit : FCC PART 15 PEAK 2.4
 Env. / Ins. : 8593EM 24*C/51%
 Engineer : Tony
 EUT : 2.4G Wireless Mouse
 Power : DC 3V
 M/N : DOK-M159W
 Test Mode : TX 2442MHz

Emission				
Freq. (MHz)	Level (dBuV/m)	Limits (dBuV/m)	Margin (dB)	Remark
1 20940.000	62.22	74.00	11.78	Peak
2 20940.000	50.75	54.00	3.25	Average
3 23985.000	64.17	74.00	9.83	Peak
4 23985.000	50.40	54.00	3.60	Average

Remarks: Emission Level = Antenna Factor + Cable Loss + Reading - AMP Factor



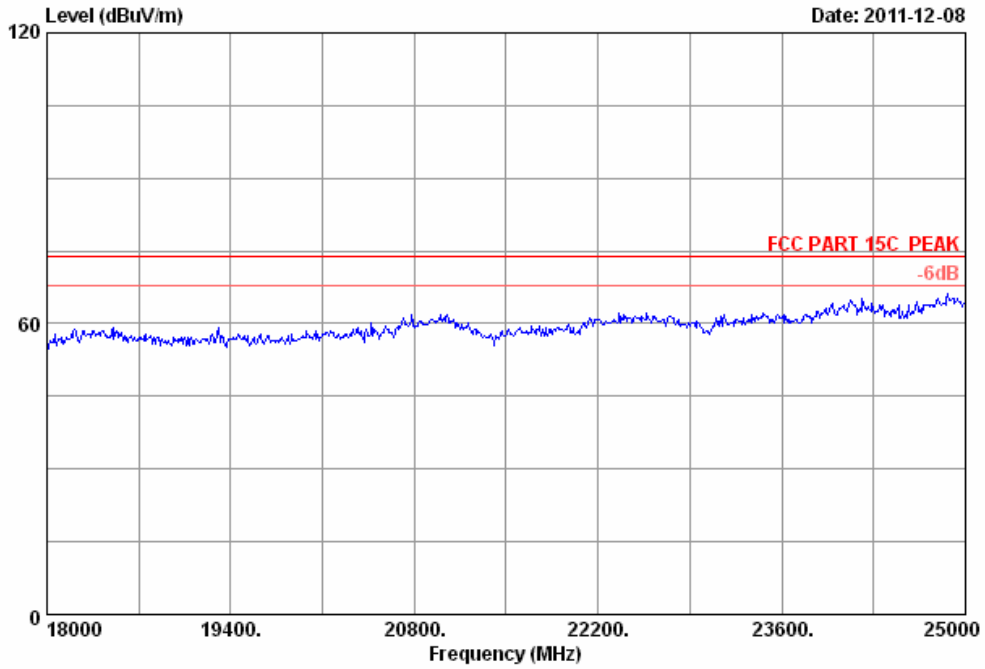

Site no. : 3m Chamber Data no. : 19
Dis. / Ant. : 3m 3115 FACTOR Ant. pol. : HORIZONTAL
Limit : FCC PART 15 PEAK 2.4
Env. / Ins. : 8593EM 24*C/51%
Engineer : Tony
EUT : 2.4G Wireless Mouse
Power : DC 3V
M/N : DOK-M159W
Test Mode : TX 2442MHz

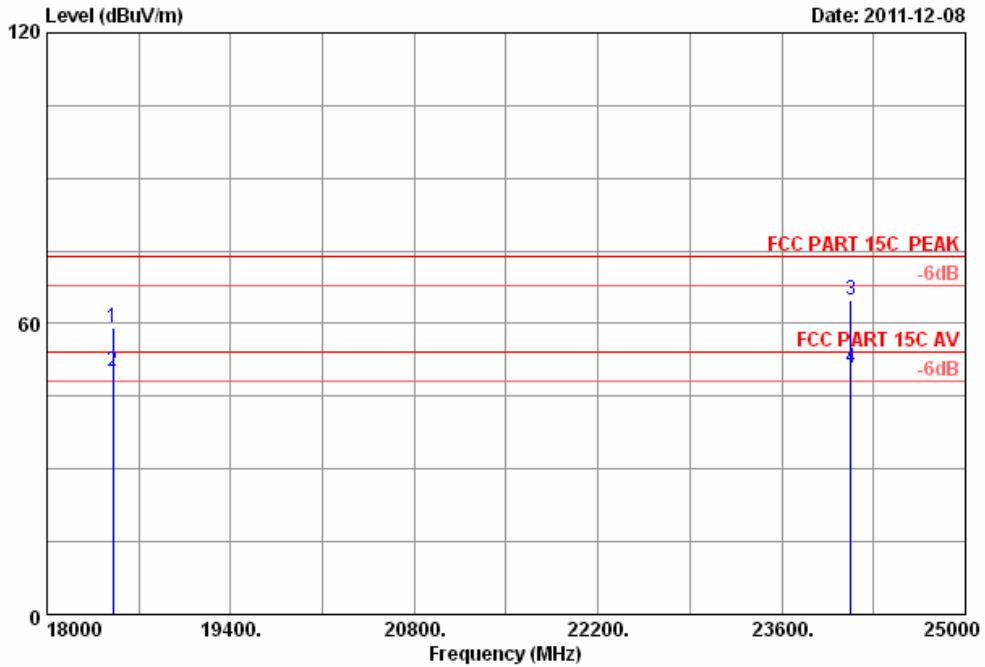

```

Site no.      : 3m Chamber                Data no. : 20
Dis. / Ant.  : 3m 3115 FACTOR            Ant. pol. : HORIZONTAL
Limit        : FCC PART 15 PEAK 2.4
Env. / Ins.  : 8593EM 24*C/51%
Engineer     : Tony
EUT          : 2.4G Wireless Mouse
Power        : DC 3V
M/N          : DOK-M159W
Test Mode    : TX 2442MHz
    
```

Emission				
Freq. (MHz)	Level (dBuV/m)	Limits (dBuV/m)	Margin (dB)	Remark
1 18504.000	59.21	74.00	14.79	Peak
2 18504.000	50.06	54.00	3.94	Average
3 24125.000	64.69	74.00	9.31	Peak
4 24125.000	50.75	54.00	3.25	Average

Remarks: Emission Level = Antenna Factor + Cable Loss + Reading - AMP Factor

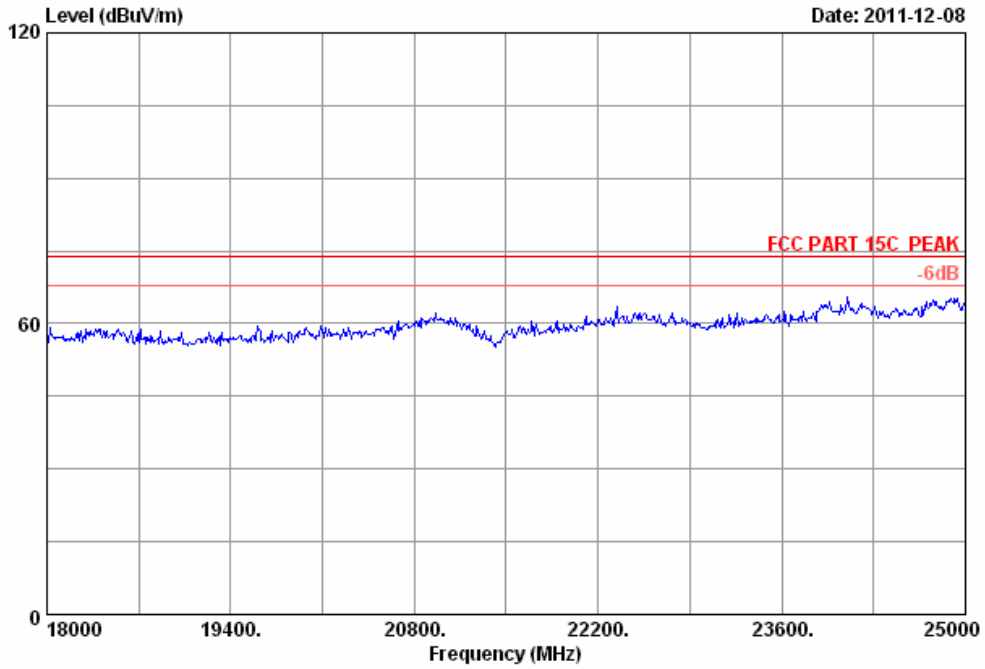

Site no. : 3m Chamber Data no. : 21
Dis. / Ant. : 3m 3115 FACTOR Ant. pol. : HORIZONTAL
Limit : FCC PART 15 PEAK 2.4
Env. / Ins. : 8593EM 24*C/51%
Engineer : Tony
EUT : 2.4G Wireless Mouse
Power : DC 3V
M/N : DOK-M159W
Test Mode : TX 2478MHz

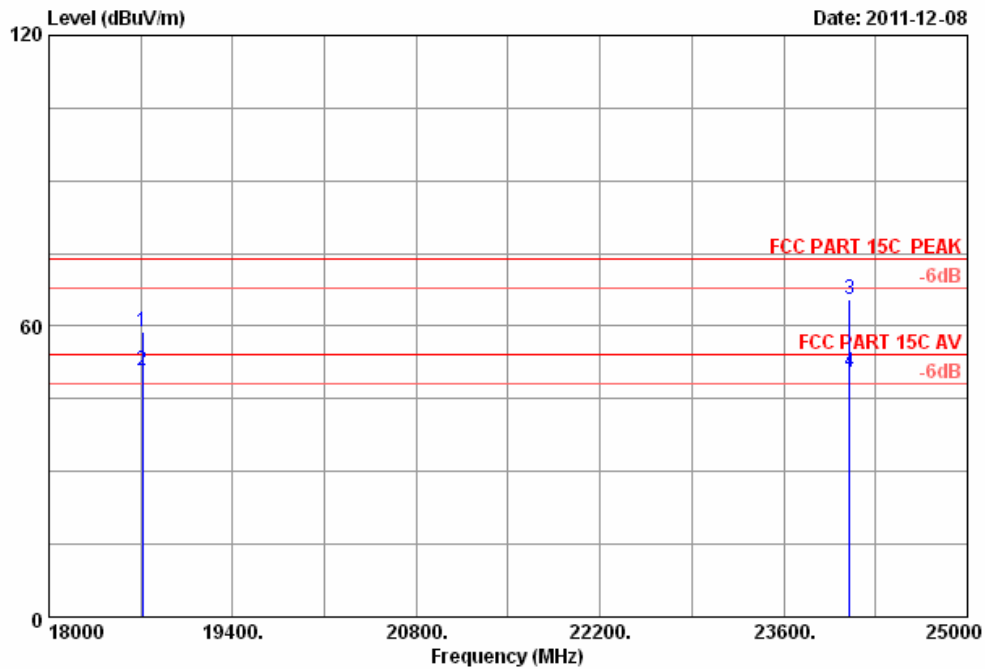

Site no. : 3m Chamber
 Dis. / Ant. : 3m 3115 FACTOR
 Limit : FCC PART 15 PEAK 2.4
 Env. / Ins. : 8593EM 24*C/51%
 Engineer : Tony
 EUT : 2.4G Wireless Mouse
 Power : DC 3V
 M/N : DOK-M159W
 Test Mode : TX 2478MHz
 Data no. : 22
 Ant. pol. : HORIZONTAL

Emission					
	Freq. (MHz)	Level (dBuV/m)	Limits (dBuV/m)	Margin (dB)	Remark
1	18714.000	58.97	74.00	15.03	Peak
2	18714.000	50.83	54.00	3.17	Average
3	24104.000	65.41	74.00	8.59	Peak
4	24104.000	50.41	54.00	3.59	Average

Remarks: Emission Level = Antenna Factor + Cable Loss + Reading - AMP Factor



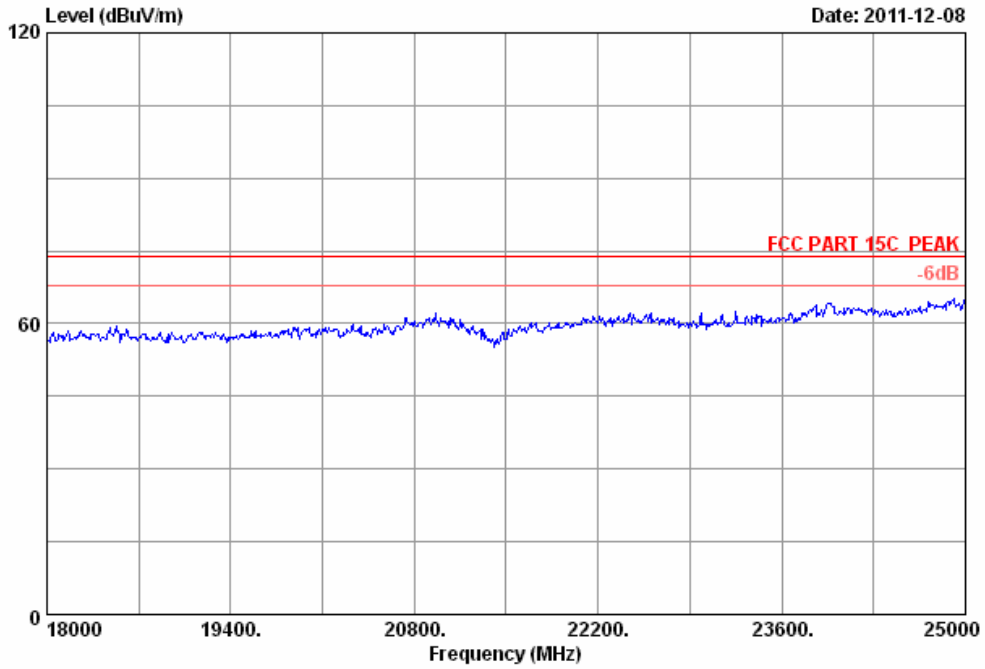

Site no. : 3m Chamber Data no. : 23
Dis. / Ant. : 3m 3115 FACTOR Ant. pol. : VERTICAL
Limit : FCC PART 15 PEAK 2.4
Env. / Ins. : 8593EM 24*C/51%
Engineer : Tony
EUT : 2.4G Wireless Mouse
Power : DC 3V
M/N : DOK-M159W
Test Mode : TX 2478MHz

5. 20 DB BANDWIDTH TEST

5.1. Test Equipment

Item	Equipment	Manufacturer	Model No.	Serial No.	Last Cal.	Cal. Interval
1.	Spectrum Analyz	Rohde &Schwarz	ESL	1106/2011	Nov 29.11	1 Year

5.2. Limit

Intentional radiators operating under the alternative provisions to the general emission limits, as contained in §§ 15.217 through 15.257 and in Subpart E of this part, must be designed to ensure that the 20 dB bandwidth of the emission, or whatever bandwidth may otherwise be specified in the specific rule section under which the equipment operates, is contained within the frequency band designated in the rule section under which the equipment is operated.

5.3. Test Results

EUT: 2.4G Wireless Mouse		
M/N: DOK-M159W		
Test date:2011-12-16	Pressure:101.4 kpa	Humidity:57 %
Tested by: Tony	Test site: RF site	Temperature : 24.1 °C

Frequency	20% bandwidth (MHz)	Limit (KHz)
2402	0.523	N/A
2442	0.391	N/A
2478	0.475	N/A
Conclusion : PASS		

Test Frequency: 2402MHz



* Att 20 dB * RBW 100 kHz D2[1] -20.73 dB
Ref 10.0 dBm VBW 300 kHz 247.50000000 kHz
* SWT 10ms

1Pk View

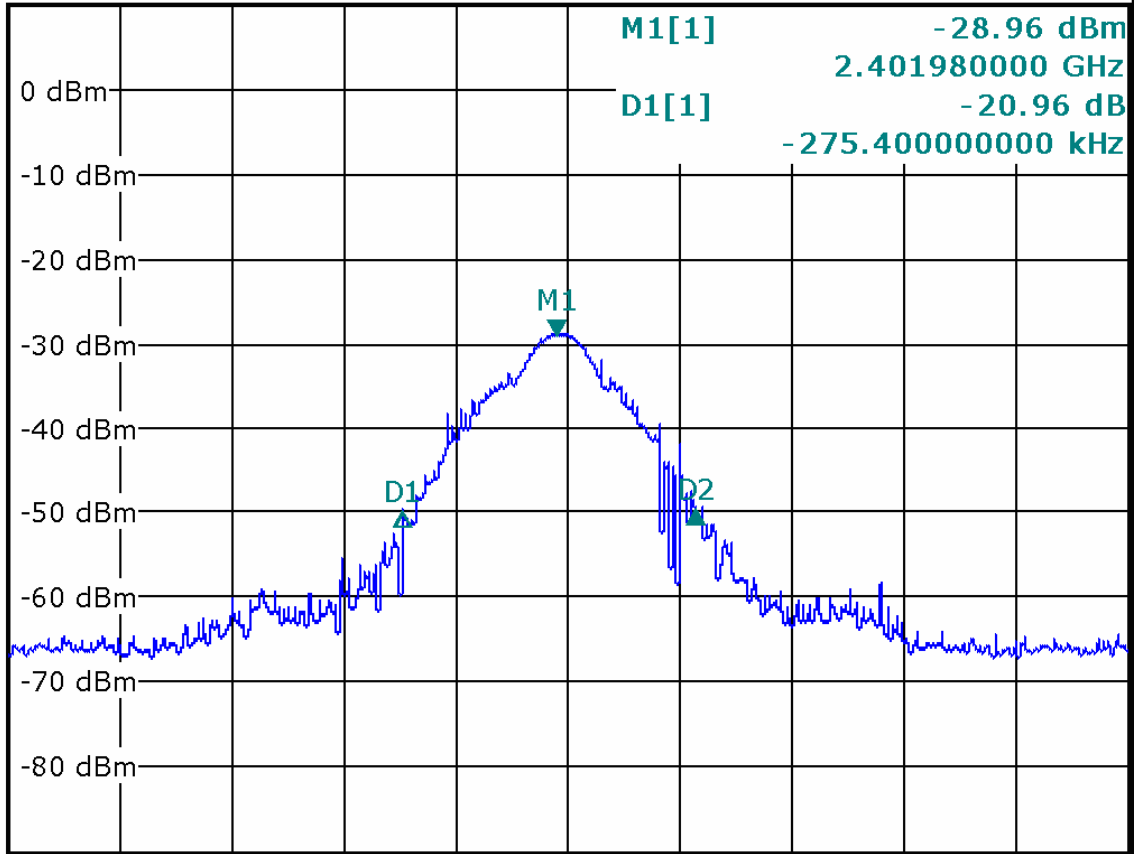

CF 2.402 GHz

Span 2.0 MHz

Test Frequency: 2442MHz



* Att 20 dB * RBW 100 kHz D2[1] -20.80 dB
Ref 10.0 dBm VBW 300 kHz 203.60000000 kHz
* SWT 10ms

1Pk View

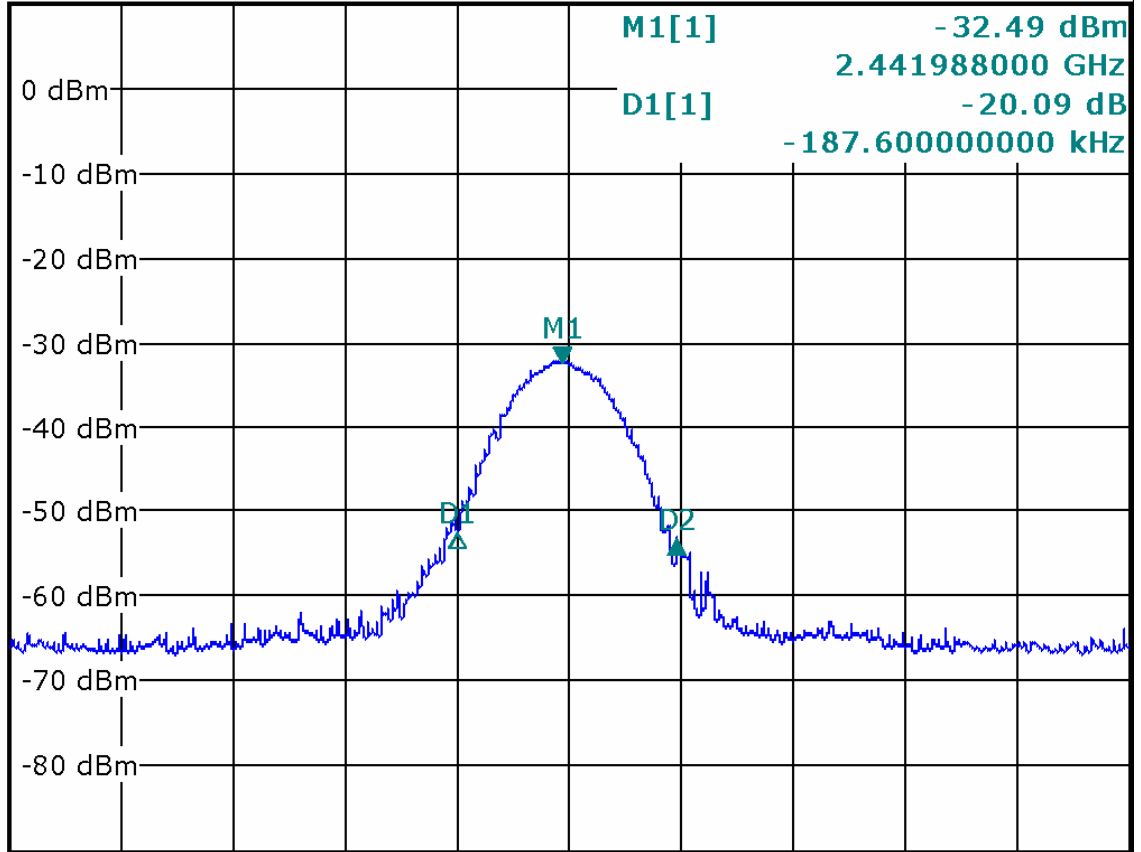

CF 2.442 GHz

Span 2.0 MHz

Test Frequency: 2478MHz



* Att 20 dB * RBW 100 kHz D2[1] -20.03 dB
Ref 10.0 dBm VBW 300 kHz 243.50000000 kHz
* SWT 10ms

1Pk View

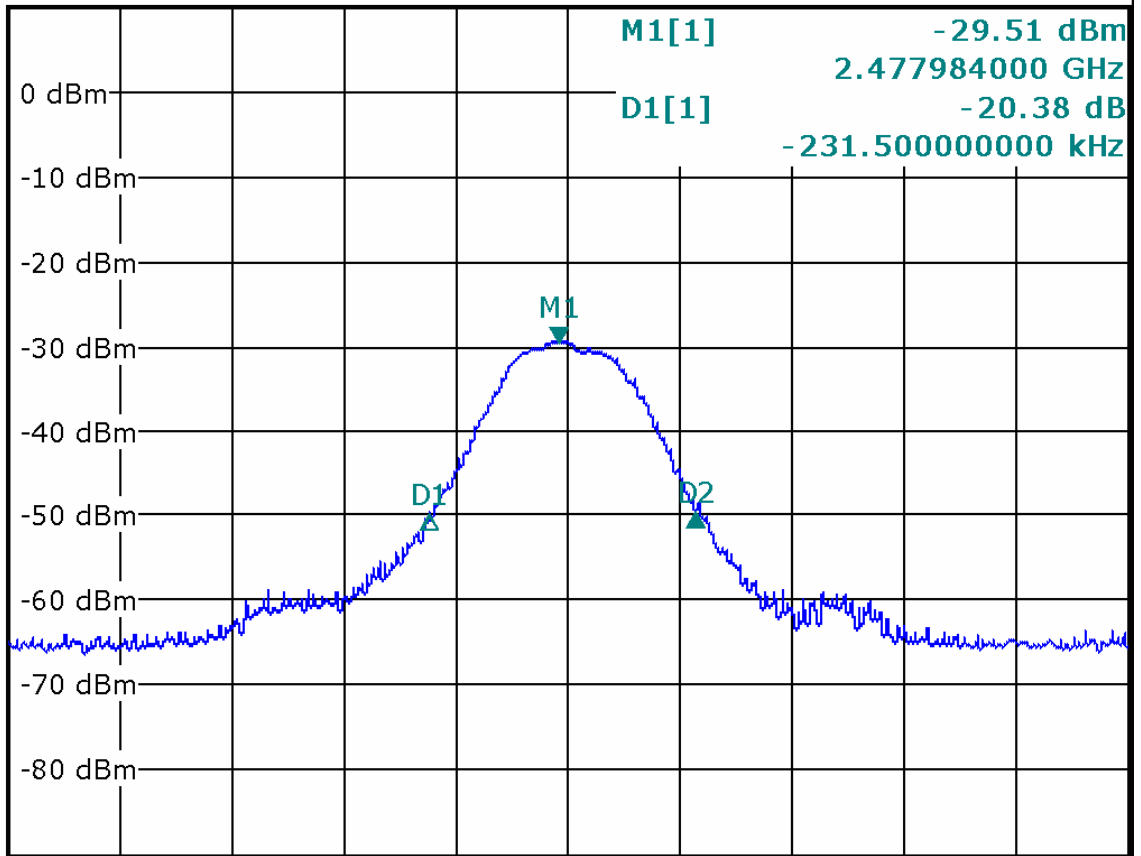

CF 2.478 GHz

Span 2.0 MHz

6. BAND EDGE COMPLIANCE TEST

6.1. Test Equipment

Item	Equipment	Manufacturer	Model No.	Serial No.	Last Cal.	Cal. Interval
1.	Spectrum Analyzer	Agilent	E4446A	US44300459	May.08,11	1 Year
2.	Horn Antenna	EMCO	3115	9607-4877	Nov.25, 11	1.5 Year
3.	Amplifier	Agilent	8449B	3008A02495	May.08, 11	1 Year
4.	RF Cable	Hubersuhner	SUCOFLEX102	28620/2	May.08,11	1 Year
5.	RF Cable	Hubersuhner	SUCOFLEX102	28618/2	May.08,11	1 Year
6.	RF Cable	Hubersuhner	SUCOFLEX102	28610/2	May.08,11	1 Year

6.2. Limit

All the lower and upper band-edges emissions appearing within 2310MHz to 2390MHz and 2483.5MHz to 2500MHz restricted frequency bands shall not exceed the limits shown in 15.209, all the other emissions outside operation frequency band 2400MHz to 2483.5MHz shall be at least 20dB below the fundamental emissions, or comply with 15.209 limits.

6.3. Test Produce

1. The EUT is placed on a turntable, which is 0.8m above the ground plane and worked at highest radiated power.
2. The turntable was rotated for 360 degrees to determine the position of maximum emission level.
3. EUT is set 3m away from the receiving antenna, which is varied from 1m to 4m to find out the highest emission.
4. Set the spectrum analyzer in the following setting in order to capture the lower and upperband-edges of the emission:
 - (a) PEAK: RBW=1MHz ;VBW=3MHz, PK detector, Sweep=AUTO
 - (b) Average: RBW=1MHz ;VBW=10Hz, PK detector, Sweep=AUTO

6.4. Test Results

Pass (The testing data was attached in the next pages.)

Note: If the PK measured levels comply with average limit, then the average level were deemed to comply with average limit.

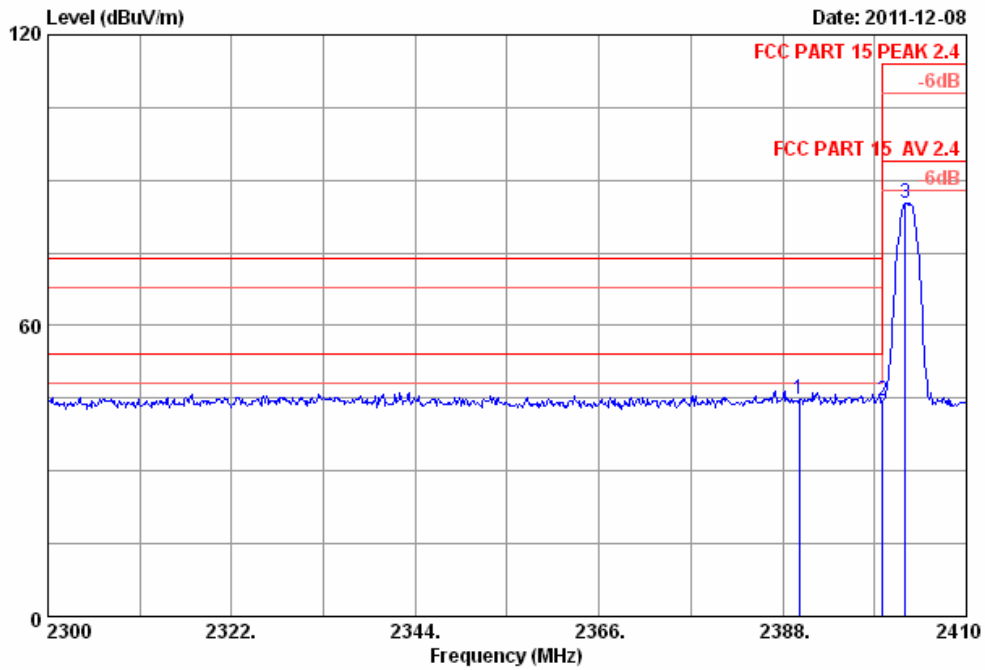

Site no. : 3m Chamber Data no. : 25
 Dis. / Ant. : 3m 3115 FACTOR Ant. pol. : HORIZONTAL
 Limit : FCC PART 15 PEAK 2.4
 Env. / Ins. : 8593EM 24*C/51%
 Engineer : Tony
 EUT : 2.4G Wireless Mouse
 Power : DC 3V
 M/N : DOK-M159W
 Test Mode : TX 2402MHz

Emission					
	Freq. (MHz)	Level (dBuV/m)	Limits (dBuV/m)	Margin (dB)	Remark
1	2390.000	44.89	74.00	29.11	Peak
2	2400.000	44.42	74.00	29.58	Peak
3	2402.630	85.11	114.00	28.89	Peak

Remarks: Emission Level = Antenna Factor + Cable Loss + Reading - AMP Factor

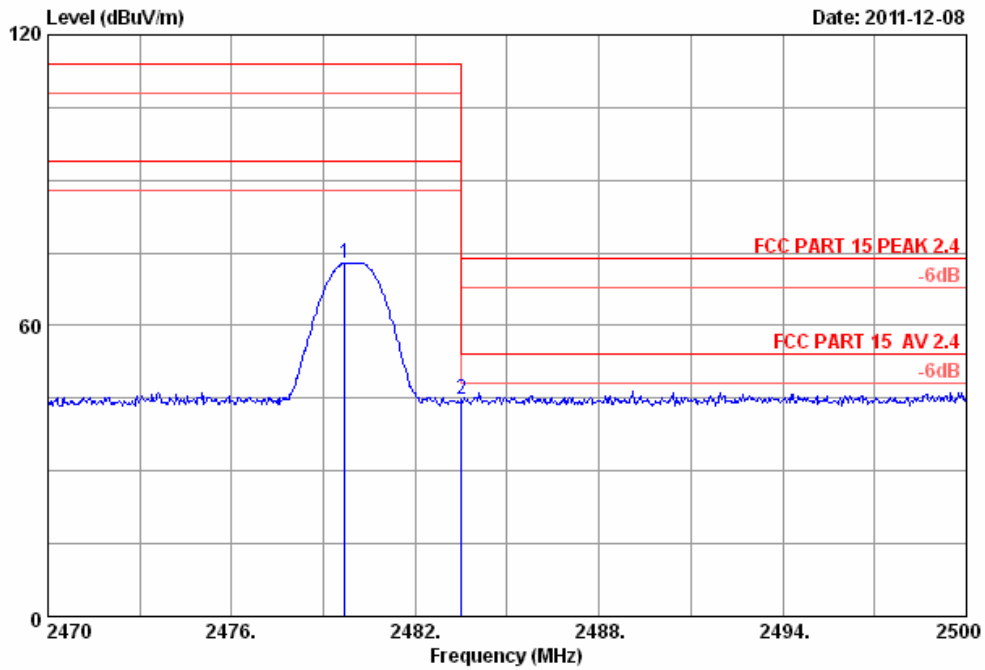

```

Site no.      : 3m Chamber                Data no. : 27
Dis. / Ant.  : 3m 3115 FACTOR            Ant. pol.: VERTICAL
Limit        : FCC PART 15 PEAK 2.4
Env. / Ins.  : 8593EM 24*C/51%
Engineer     : Tony
EUT          : 2.4G Wireless Mouse
Power        : DC 3V
M/N          : DOK-M159W
Test Mode    : TX 2478MHz
    
```

Emission					
	Freq. (MHz)	Level (dBuV/m)	Limits (dBuV/m)	Margin (dB)	Remark
1	2478.690	72.96	114.00	41.04	Peak
2	2483.500	44.94	74.00	29.06	Peak

Remarks: Emission Level = Antenna Factor + Cable Loss + Reading - AMP Factor

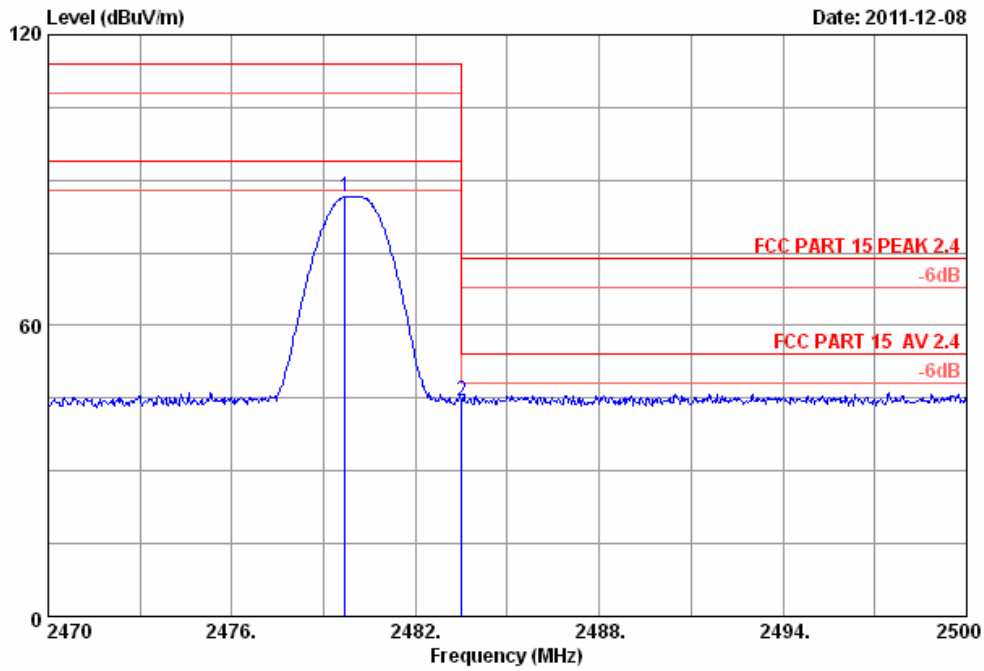

Site no. : 3m Chamber Data no. : 28
 Dis. / Ant. : 3m 3115 FACTOR Ant. pol. : HORIZONTAL
 Limit : FCC PART 15 PEAK 2.4
 Env. / Ins. : 8593EM 24*C/51%
 Engineer : Tony
 EUT : 2.4G Wireless Mouse
 Power : DC 3V
 M/N : DOK-M159W
 Test Mode : TX 2478MHz

Emission					
	Freq. (MHz)	Level (dBuV/m)	Limits (dBuV/m)	Margin (dB)	Remark
1	2478.690	86.61	114.00	27.39	Peak
2	2483.500	44.44	74.00	29.56	Peak

Remarks: Emission Level = Antenna Factor + Cable Loss + Reading - AMP Factor

7. PHOTOGRAPH OF TEST

7.1.Photos of Radiated Emission Test (30-1000MHz)

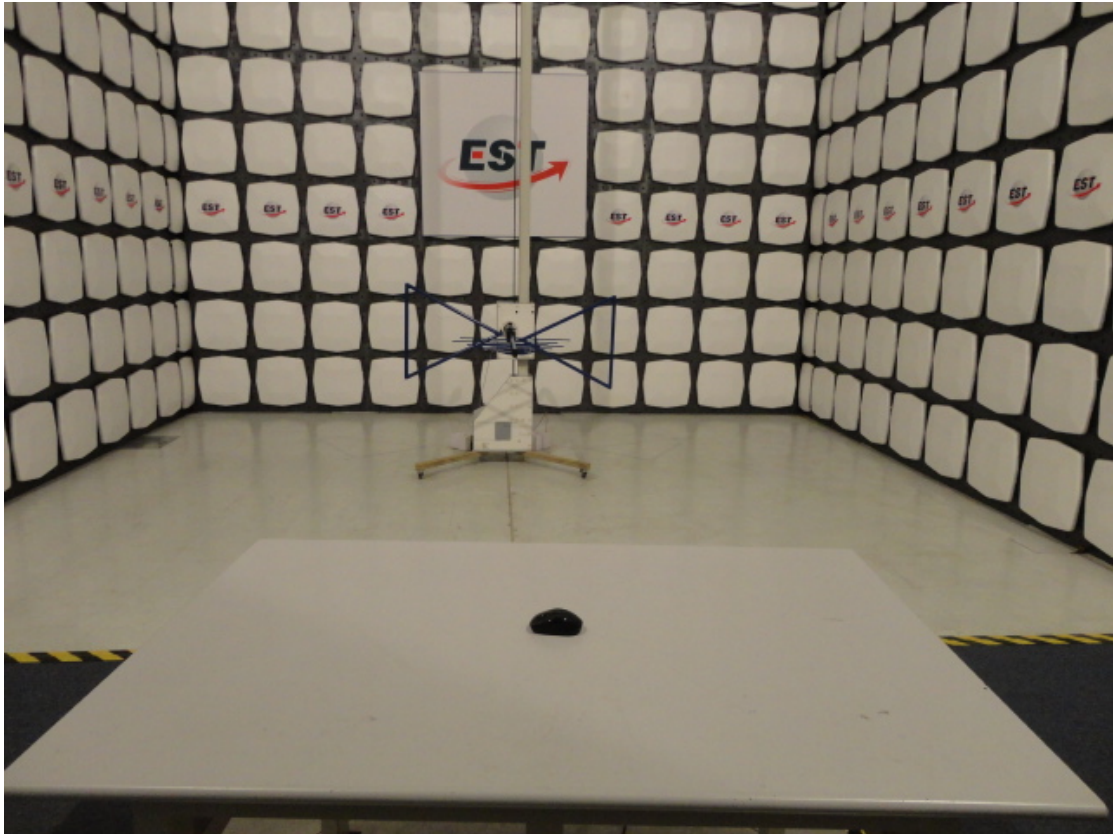

(Above 1000MHz)

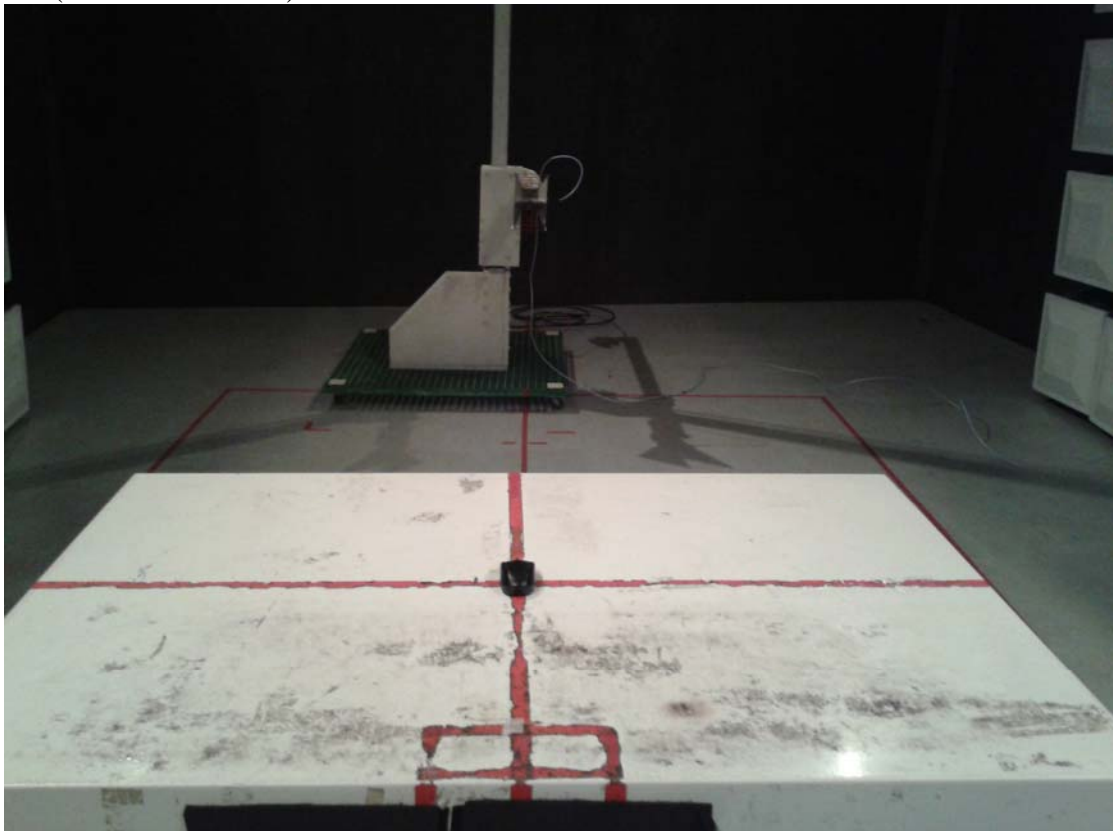

8. PHOTOGRAPH OF EUT

Figure 1
General Appearance of the EUT



Figure 2
General Appearance of the EUT



Figure 3
Inside of the EUT

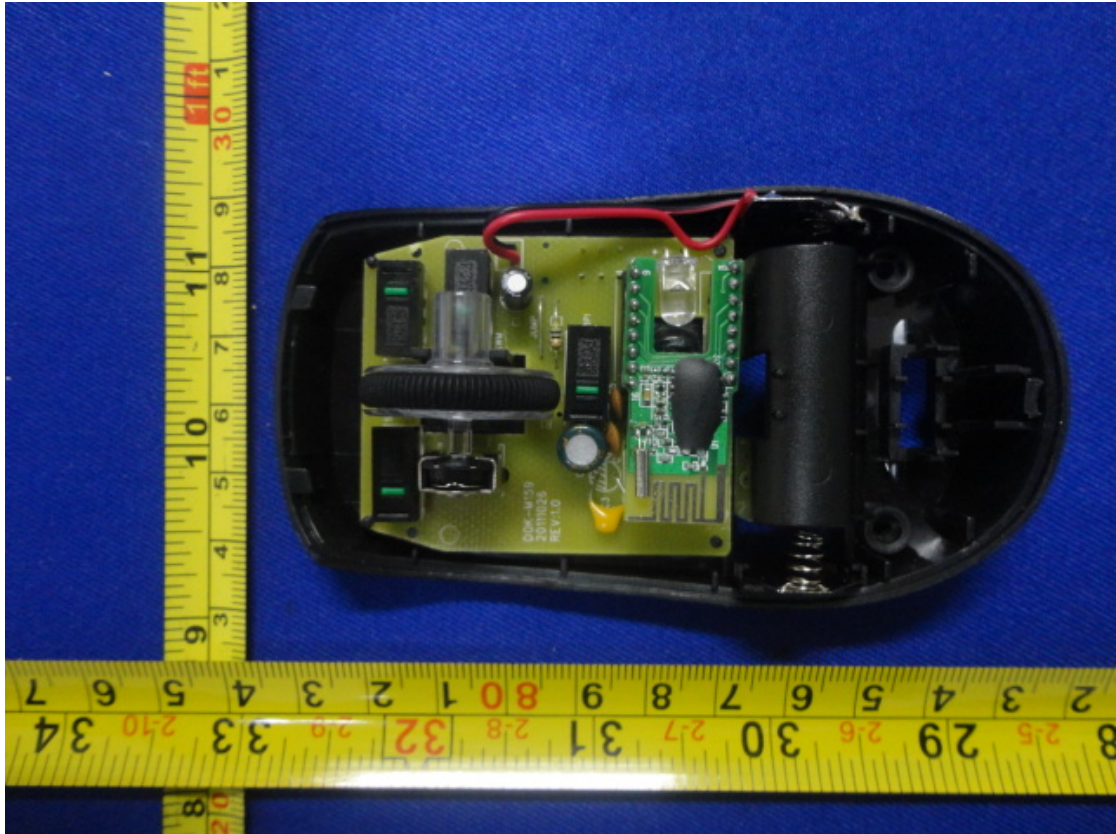

Figure 4
Inside of the EUT

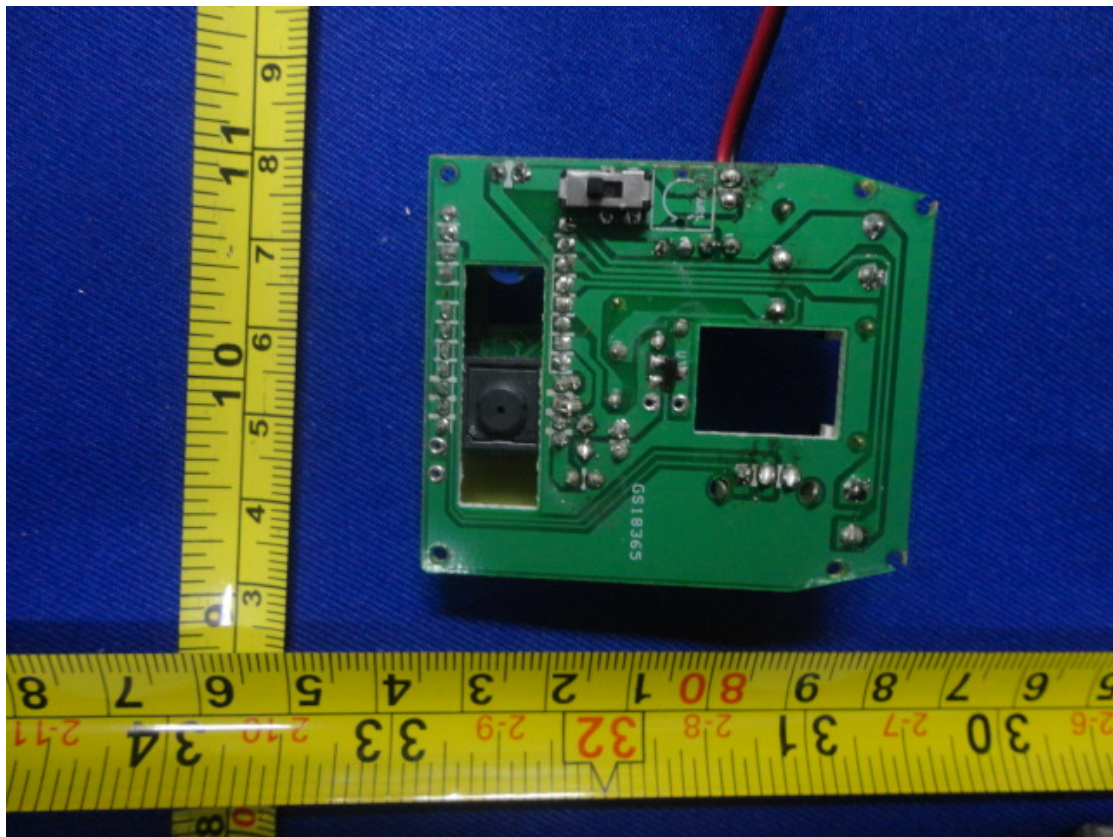

Figure 5
Inside of the EUT

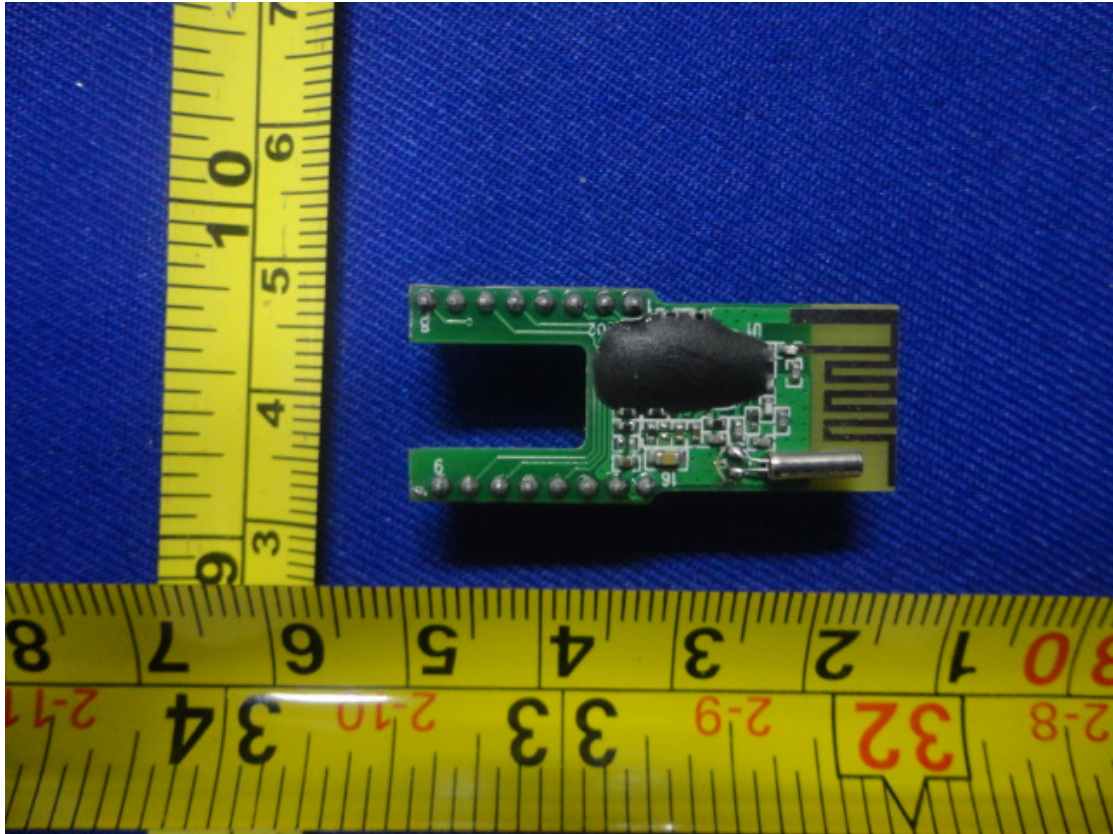

Figure 6
Inside of the EUT

