



FCC RF Test Report

APPLICANT : Locus Solutions
EQUIPMENT : 2G Tracker
BRAND NAME : LOCUS TRAXX
MODEL NAME : SmartTraxx go 1.1
MARKETING NAME : GO
FCC ID : AMH101006
STANDARD : FCC 47 CFR Part 2, 22(H), 24(E)
CLASSIFICATION : PCS Licensed Transmitter (PCB)

The product was received on Nov. 18, 2015 and testing was completed on Dec. 16, 2015. We, SPORTON INTERNATIONAL (SHENZHEN) INC., would like to declare that the tested sample has been evaluated in accordance with the test procedures given in ANSI / TIA / EIA-603-D-2010 and has been in compliance with the applicable technical standards.

The test results in this report apply exclusively to the tested model / sample. Without written approval of SPORTON INTERNATIONAL (SHENZHEN) INC., the test report shall not be reproduced except in full.

Prepared by: Andy Yeh / Manager

Approved by: Jones Tsai / Manager



SPORTON INTERNATIONAL (SHENZHEN) INC.

**1F & 2F, Building A, Morning Business Center, No. 4003 ShiGu Rd., Xili Town,
Nanshan District, Shenzhen, Guangdong, P. R. China**



TABLE OF CONTENTS

REVISION HISTORY..... 3

SUMMARY OF TEST RESULT 4

1 GENERAL DESCRIPTION 6

1.1 Applicant..... 6

1.2 Manufacturer 6

1.3 Product Feature of Equipment Under Test 6

1.4 Product Specification subjective to this standard..... 7

1.5 Modification of EUT 8

1.6 Maximum ERP/EIRP Power, Frequency Tolerance, and Emission Designator 8

1.7 Testing Location 9

1.8 Applicable Standards 9

2 TEST CONFIGURATION OF EQUIPMENT UNDER TEST 10

2.1 Test Mode..... 10

2.2 Connection Diagram of Test System 10

2.3 Support Unit used in test configuration 11

2.4 Measurement Results Explanation Example 11

3 CONDUCTED TEST RESULT..... 12

3.1 Measuring Instruments 12

3.2 Test Setup 12

3.3 Test Result of Conducted Test..... 12

3.4 Conducted Output Power 13

3.5 Peak-to-Average Ratio 14

3.6 99% Occupied Bandwidth and 26dB Bandwidth Measurement..... 15

3.7 Conducted Band Edge 16

3.8 Conducted Spurious Emission 17

3.9 Frequency Stability 18

4 RADIATED TEST ITEMS 19

4.1 Measuring Instruments 19

4.2 Test Setup 19

4.3 Test Result of Radiated Test..... 19

4.4 Effective Radiated Power and Effective Isotropic Radiated Power Measurement 20

4.5 Field Strength of Spurious Radiation Measurement 22

5 LIST OF MEASURING EQUIPMENT 23

6 UNCERTAINTY OF EVALUATION 24

APPENDIX A. TEST RESULTS OF CONDUCTED TEST

APPENDIX B. TEST RESULTS OF RADIATED TEST

APPENDIX C. TEST SETUP PHOTOGRAPHS



SUMMARY OF TEST RESULT

Report Section	FCC Rule	IC Rule	Description	Limit	Result	Remark
3.4	§2.1046	RSS-132 (5.4) RSS-133 (6.4)	Conducted Output Power	Reporting Only	PASS	-
3.5	§24.232(d)	RSS-132 (5.4) RSS-133 (6.4)	Peak-to-Average Ratio	< 13 dB	PASS	-
3.6	§2.1049 §22.917(b) §24.238(b)	RSS-GEN(6.6) RSS-132(3.1) RSS-133(3.1)	Occupied Bandwidth	Reporting Only	PASS	-
3.7	§2.1051 §22.917(a) §24.238(a)	RSS-132 (5.5) RSS-133 (6.5)	Band Edge Measurement	< 43+10log10(P[Watts])	PASS	-
3.8	§2.1051 §22.917(a) §24.238(a)	RSS-132 (5.5) RSS-133 (6.5)	Conducted Emission	< 43+10log10(P[Watts])	PASS	-
3.9	§2.1055 §22.355	RSS-GEN(6.11) RSS-132 (5.3)	Frequency Stability for Temperature & Voltage	< 2.5 ppm for Part 22	PASS	-
	§2.1055 §24.235	RSS-GEN(6.11) RSS-133 (6.3)		Within Authorized Band		



Report Section	FCC Rule	IC Rule	Description	Limit	Result	Remark
4.4	§22.913(a)(2)	RSS-132(5.4) SRSP-503(5.1.3)	Effective Radiated Power	< 7 Watts	PASS	-
	§24.232(c)	RSS-133 (6.4) SRSP-510(5.1.2)	Equivalent Isotropic Radiated Power	< 2 Watts	PASS	-
4.5	§2.1053 §22.917(a) §24.238(a)	RSS-132 (5.5) RSS-133 (6.5)	Field Strength of Spurious Radiation	< 43+10log10(P[Watts])	PASS	Under limit 0.69 dB at 5550.600 MHz



1 General Description

1.1 Applicant

Locus Solutions

14924 Corporate Rd S, Jupiter, FL 33478, USA

1.2 Manufacturer

Shenzhen Zhenhua Communication Equipment Co. Ltd

Zhenhua Industrial Park, No.44, Tiezai Rd., Xixiang Town, BaoAn, Shenzhen, Guang Dong, China

1.3 Product Feature of Equipment Under Test

Product Feature	
Equipment	2G Tracker
Brand Name	LOCUS TRAXX
Model Name	SmartTraxx go 1.1
Marketing Name	GO
FCC ID	AMH101006
EUT supports Radios application	GPRS
IMEI Code	Conducted: 352477070000124 Radiation: 352477070000199 ERP/EIRP: 352477070000199
HW Version	TK108_61_V10
SW Version	M6100_1.9.8
EUT Stage	Identical Prototype

Remark: The above EUT's information was declared by manufacturer. Please refer to the specifications or user's manual for more detailed description.



1.4 Product Specification subjective to this standard

Product Specification subjective to this standard	
Tx Frequency	GPRS: 850: 824.2 MHz ~ 848.8 MHz 1900: 1850.2 MHz ~ 1909.8MHz
Rx Frequency	GPRS: 850: 869.2 MHz ~ 893.8 MHz 1900: 1930.2 MHz ~ 1989.8 MHz
Maximum Output Power to Antenna	GPRS: 850: 32.87 dBm 1900: 29.62 dBm
Antenna Type	Helical Antenna
Type of Modulation	GPRS: GMSK



1.5 Modification of EUT

No modifications are made to the EUT during all test items.

1.6 Maximum ERP/EIRP Power, Frequency Tolerance, and Emission Designator

FCC Rule	System	Type of Modulation	Maximum ERP/EIRP (W)	Frequency Tolerance (ppm)	Emission Designator
Part 22	GSM850 GPRS class 8	GMSK	0.8128	0.0179 ppm	244KGXW
Part 24	GSM1900 GPRS class 8	GMSK	0.8790	0.0120 ppm	247KGXW



1.7 Testing Location

Test Site	SPORTON INTERNATIONAL (SHENZHEN) INC.	
Test Site Location	1F & 2F, Building A, Morning Business Center, No. 4003 ShiGu Rd., Xili Town, Nanshan District, Shenzhen, Guangdong, P. R. China TEL: +86-755-8637-9589 FAX: +86-755-8637-9595	
Test Site No.	Sporton Site No.	
	TH01-SZ	

Test Site	SPORTON INTERNATIONAL (SHENZHEN) INC.	
Test Site Location	No. 3 Building, the third floor of south, Shahe River west, Fengzeyuan warehouse, Nanshan District, Shenzhen, Guangdong, P. R. China TEL: +86-755- 3320-2398	
Test Site No.	Sporton Site No.	FCC/IC Registration No.
	03CH01-SZ	831040/4086F

1.8 Applicable Standards

According to the specifications of the manufacturer, the EUT must comply with the requirements of the following standards:

- 47 CFR Part 2, 22(H), 24(E)
- ANSI / TIA / EIA-603-D-2010
- FCC KDB 971168 D01 Power Meas. License Digital Systems v02r02
- IC RSS-132 Issue 3
- IC RSS-133 Issue 6
- IC RSS-Gen Issue 4

Remark:

1. All test items were verified and recorded according to the standards and without any deviation during the test.
2. This EUT has also been tested and complied with the requirements of FCC Part 15, Subpart B, recorded in a separate test report.

2 Test Configuration of Equipment Under Test

2.1 Test Mode

Antenna port conducted and radiated test items were performed according to KDB 971168 D01 Power Meas. License Digital Systems v02r02 with maximum output power.

Radiated measurements were performed with rotating EUT in different three orthogonal test planes to find the maximum emission.

Radiated emissions were investigated as following frequency range:

1. 30 MHz to 10th harmonic for GSM850.
2. 30 MHz to 10th harmonic for GSM1900.

All modes and data rates and positions were investigated.

Test modes are chosen to be reported as the worst case configuration below:

Test Modes		
Band	Radiated TCs	Conducted TCs
GSM 850	■ GPRS class 8 Link	■ GPRS class 8 Link
GSM 1900	■ GPRS class 8 Link	■ GPRS class 8 Link

2.2 Connection Diagram of Test System

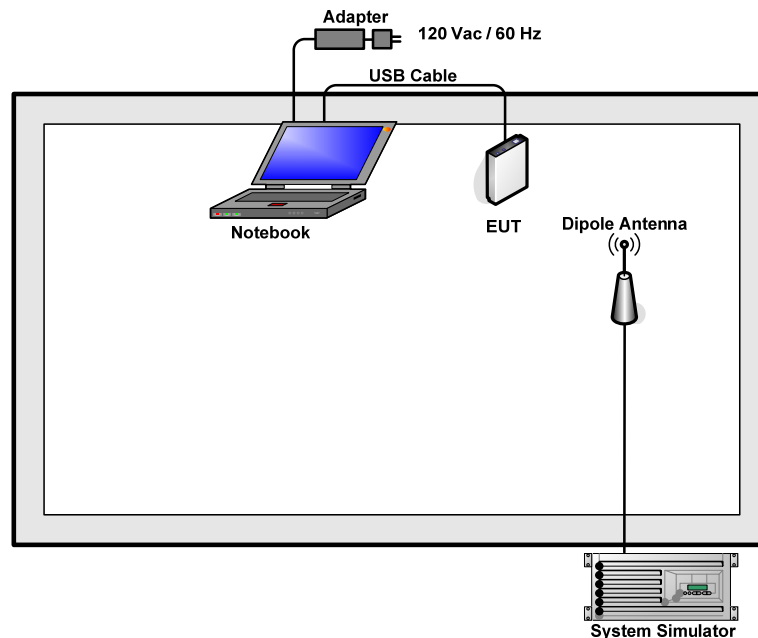

2.3 Support Unit used in test configuration

Item	Equipment	Trade Name	Model No.	FCC ID	Data Cable	Power Cord
1.	System Simulator	Anritsu	MT8820C	N/A	N/A	Unshielded, 1.8 m
2.	Notebook	Lenovo	E540	FCC DoC	N/A	AC I/P: Unshielded, 1.2 m DC O/P: Shielded, 1.8 m
3.	USB Cable	Motorola	SKN6378A	FCC DoC	N/A	Unshielded, 1.8 m
4.	DC Power Supply	GW INSTEK	GPS-3030D	N/A	N/A	Unshielded, 1.8 m

2.4 Measurement Results Explanation Example

For all conducted test items:

The offset level is set in the spectrum analyzer to compensate the RF cable loss and attenuator factor between RF conducted output port and spectrum analyzer. With the offset compensation, the spectrum analyzer reading level will be exactly the RF output level.

The spectrum analyzer offset is derived from RF cable loss and attenuator factor.

$$\text{Offset} = \text{RF cable loss} + \text{attenuator factor}.$$

The following shows an offset computation example with RF cable loss 5.0 dB and a 10dB attenuator.

Example :

$$\begin{aligned} \text{Offset(dB)} &= \text{RF cable loss(dB)} + \text{attenuator factor(dB)}. \\ &= 5.0 + 10 = 15.0 \text{ (dB)} \end{aligned}$$

3 Conducted Test Result

3.1 Measuring Instruments

See list of measuring instruments of this test report.

3.2 Test Setup

3.2.1 Conducted Output Power

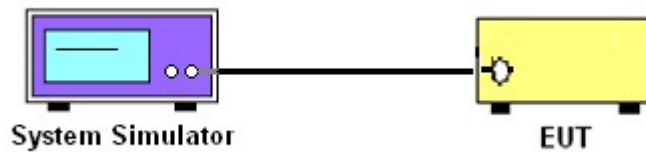

3.2.2 Peak-to-Average Ratio, Occupied Bandwidth, Conducted Band-Edge and Conducted Spurious Emission

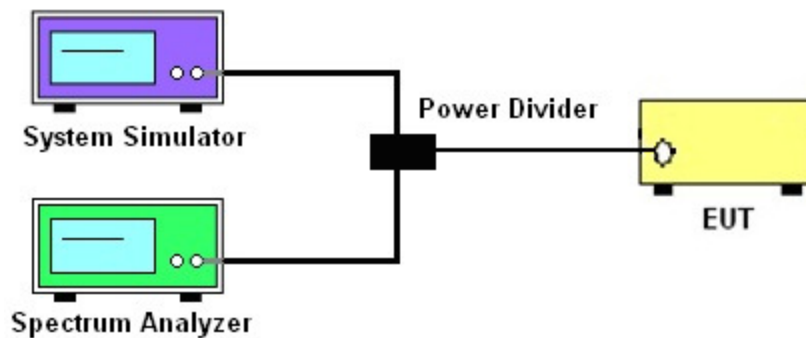

3.2.3 Frequency Stability

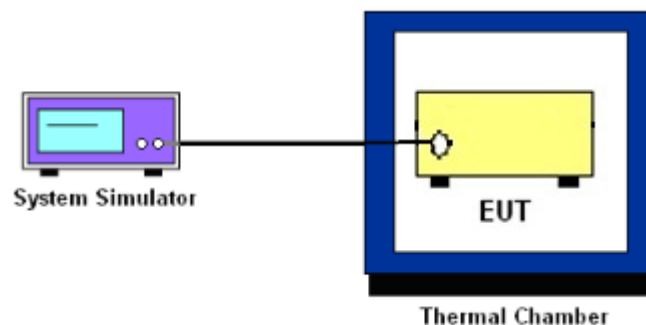

3.3 Test Result of Conducted Test

Please refer to Appendix A.



3.4 Conducted Output Power

3.4.1 Description of the Conducted Output Power

A system simulator was used to establish communication with the EUT. Its parameters were set to enforce EUT transmitting at the maximum power. The measured power in the radio frequency on the transmitter output terminals shall be reported.

3.4.2 Test Procedures

1. The transmitter output port was connected to the system simulator.
2. Set EUT at maximum power through system simulator.
3. Select lowest, middle, and highest channels for each band and different modulation.
4. Measure the maximum burst average power for GSM and maximum average power for other modulation signal.



3.5 Peak-to-Average Ratio

3.5.1 Description of the PAR Measurement

The peak-to-average ratio (PAR) of the transmission may not exceed 13 dB.

3.5.2 Test Procedures

1. The testing follows FCC KDB 971168 D01 v02r02 Section 5.7.1.
2. The EUT was connected to spectrum analyzer and system simulator via a power divider.
3. Set EUT to transmit at maximum output power.
4. When the duty cycle is less than 98%, then signal gating will be implemented on the spectrum analyzer by triggering from the system simulator.
5. Set the CCDF (Complementary Cumulative Distribution Function) option of the spectrum analyzer.
Record the maximum PAPR level associated with a probability of 0.1%.



3.6 99% Occupied Bandwidth and 26dB Bandwidth Measurement

3.6.1 Description of 99% Occupied Bandwidth and 26dB Bandwidth Measurement

The occupied bandwidth is the width of a frequency band such that, below the lower and above the upper frequency limits, the mean powers emitted are each equal to a specified percentage 0.5% of the total mean transmitted power.

The 26 dB emission bandwidth is defined as the frequency range between two points, one above and one below the carrier frequency, at which the spectral density of the emission is attenuated 26 dB below the maximum in-band spectral density of the modulated signal. Spectral density (power per unit bandwidth) is to be measured with a detector of resolution bandwidth equal to approximately 1.0% of the emission bandwidth.

3.6.2 Test Procedures

1. The testing follows FCC KDB 971168 v02r02 Section 4.2.
2. The EUT was connected to spectrum analyzer and system simulator via a power divider.
3. The spectrum analyzer center frequency is set to the nominal EUT channel center frequency. The span range for the spectrum analyzer shall be between two and five times the anticipated OBW.
4. The nominal resolution bandwidth (RBW) shall be in the range of 1 to 5 % of the anticipated OBW, and the VBW shall be at least 3 times the RBW.
5. Set the detection mode to peak, and the trace mode to max hold.
6. Determine the reference value: Set the EUT to transmit a modulated signal. Allow the trace to stabilize. Set the spectrum analyzer marker to the highest level of the displayed trace.
(this is the reference value)
7. Determine the “-26 dB down amplitude” as equal to (Reference Value – X).
8. Place two markers, one at the lowest and the other at the highest frequency of the envelope of the spectral display such that each marker is at or slightly below the “-X dB down amplitude” determined in step 6. If a marker is below this “-X dB down amplitude” value it shall be placed as close as possible to this value. The OBW is the positive frequency difference between the two markers.
9. Use the 99 % power bandwidth function of the spectrum analyzer and report the measured bandwidth.



3.7 Conducted Band Edge

3.7.1 Description of Conducted Band Edge Measurement

The power of any emission outside of the authorized operating frequency ranges must be lower than the transmitter power (P) by a factor of at least $43 + 10 \log (P)$ dB.

3.7.2 Test Procedures

1. The testing follows FCC KDB 971168 D01 v02r02 Section 6.0.
2. The EUT was connected to the spectrum analyzer and system simulator via a power divider.
3. The RF output of EUT was connected to the spectrum analyzer by an RF cable and attenuator. The path loss was compensated to the results for each measurement.
4. The band edges of low and high channels for the highest RF powers were measured.
5. The RF fundamental frequency should be excluded against the limit line in the operating frequency band.
6. The limit line is derived from $43 + 10\log(P)$ dB below the transmitter power P(Watts)
= $P(W) - [43 + 10\log(P)]$ (dB)
= $[30 + 10\log(P)]$ (dBm) - $[43 + 10\log(P)]$ (dB)
= -13dBm.



3.8 Conducted Spurious Emission

3.8.1 Description of Conducted Spurious Emission Measurement

The power of any emission outside of the authorized operating frequency ranges must be lower than the transmitter power (P) by a factor of at least $43 + 10 \log (P)$ dB.

It is measured by means of a calibrated spectrum analyzer and scanned from 30 MHz up to a frequency including its 10th harmonic.

3.8.2 Test Procedures

1. The testing follows FCC KDB 971168 D01 v02r02 Section 6.0.
2. The EUT was connected to the spectrum analyzer and system simulator via a power divider.
3. The RF output of EUT was connected to the spectrum analyzer by an RF cable and attenuator. The path loss was compensated to the results for each measurement.
4. The middle channel for the highest RF power within the transmitting frequency was measured.
5. The conducted spurious emission for the whole frequency range was taken.
6. The RF fundamental frequency should be excluded against the limit line in the operating frequency band.
7. The limit line is derived from $43 + 10\log(P)$ dB below the transmitter power P(Watts)
= $P(W) - [43 + 10\log(P)]$ (dB)
= $[30 + 10\log(P)]$ (dBm) - $[43 + 10\log(P)]$ (dB)
= -13dBm.



3.9 Frequency Stability

3.9.1 Description of Frequency Stability Measurement

The frequency stability shall be measured by variation of ambient temperature and variation of primary supply voltage to ensure that the fundamental emission stays within the authorized frequency block. The frequency stability of the transmitter shall be maintained within $\pm 0.00025\%$ ($\pm 2.5\text{ppm}$) of the center frequency.

3.9.2 Test Procedures for Temperature Variation

1. The testing follows FCC KDB 971168 D01 v02r02 Section 9.0.
2. The EUT was set up in the thermal chamber and connected with the system simulator.
3. With power OFF, the temperature was decreased to -30°C and the EUT was stabilized before testing. Power was applied and the maximum change in frequency was recorded within one minute.
4. With power OFF, the temperature was raised in 10°C steps up to 50°C . The EUT was stabilized at each step for at least half an hour. Power was applied and the maximum frequency change was recorded within one minute.

3.9.3 Test Procedures for Voltage Variation

1. The testing follows FCC KDB 971168 D01 v02r02 Section 9.0.
2. The EUT was placed in a temperature chamber at $25\pm 5^{\circ}\text{C}$ and connected with the system simulator.
3. The power supply voltage to the EUT was varied from 85% to 115% of the nominal value measured at the input to the EUT.
4. The variation in frequency was measured for the worst case.

4 Radiated Test Items

4.1 Measuring Instruments

See list of measuring instruments of this test report.

4.2 Test Setup

4.2.1 For radiated test from 30MHz to 1GHz

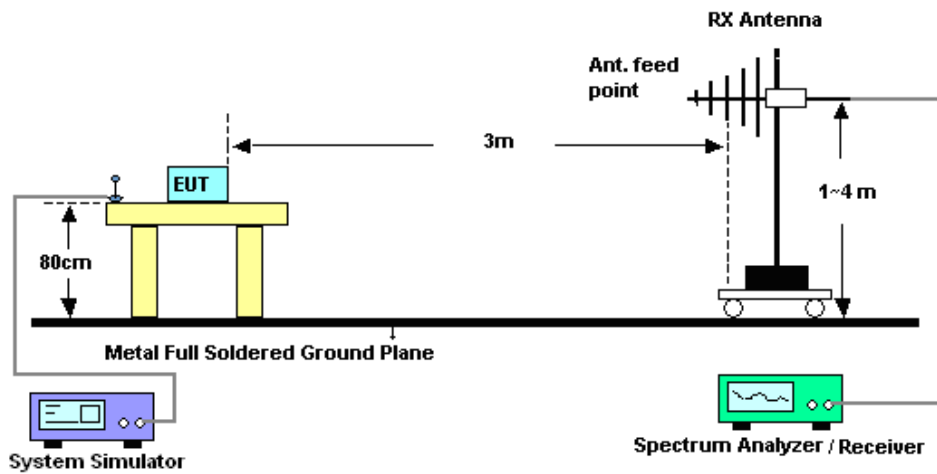

4.2.2 For radiated test above 1GHz

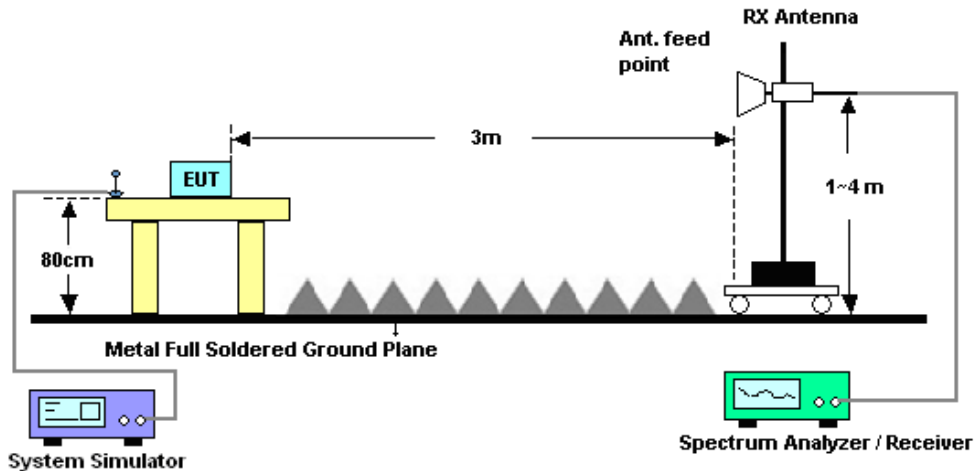

4.3 Test Result of Radiated Test

Please refer to Appendix B.



4.4 Effective Radiated Power and Effective Isotropic Radiated Power Measurement

4.4.1 Description of the ERP/EIRP Measurement

The substitution method, in ANSI / TIA / EIA-603-D-2010, was used for ERP/EIRP measurement, and the spectrum analyzer configuration follows KDB 971168 D01 Power Meas. License Digital Systems v02r02. The ERP of mobile transmitters must not exceed 7 Watts (Cellular Band) and the EIRP of mobile transmitters are limited to 2 Watts (PCS Band).

4.4.2 Test Procedures

1. The testing follows FCC KDB 971168 D01 v02r02 Section 5.2.1. (for CDMA/WCDMA), Section 5.2.2.2 (for GSM/GPRS/EDGE) and ANSI / TIA-603-D-2010 Section 2.2.17.
2. The EUT was placed on a non-conductive rotating platform 0.8 meters high in a semi-anechoic chamber. The radiated emission at the fundamental frequency was measured at 3 m with a test antenna and a spectrum analyzer with RMS detector per section 5. of KDB 971168 D01.
3. During the measurement, the system simulator parameters were set to force the EUT transmitting at maximum output power. The maximum emission was recorded from analyzer power level (LVL) from the 360 degrees rotation of the turntable and the test antenna raised and lowered over a range from 1 to 4 meters in both horizontally and vertically polarized orientations.
4. Effective Isotropic Radiated Power (EIRP) was measured by substitution method according to TIA/EIA-603-D. The EUT was replaced by the substitution antenna at same location, and then a known power from S.G. was applied into the dipole antenna through a Tx cable, and then recorded the maximum Analyzer reading through raised and lowered the test antenna. The correction factor (in dB) = S.G. - Tx Cable loss + Substitution antenna gain - Analyzer reading. Then the EUT's EIRP was calculated with the correction factor, $EIRP = LVL + \text{Correction factor}$ and $ERP = EIRP - 2.15$. Take the record of the output power at substitution antenna.



	GSM/GPRS/EDGE
SPAN	500kHz
RBW	10kHz
VBW	30kHz
Detector	RMS
Trace	Average
Average Type	Power
Sweep Count	100



4.5 Field Strength of Spurious Radiation Measurement

4.5.1 Description of Field Strength of Spurious Radiated Measurement

The power of any emission outside of the authorized operating frequency ranges must be attenuated below the transmitter power (P) by a factor of at least $43 + 10 \log (P)$ dB. The spectrum is scanned from 30 MHz up to a frequency including its 10th harmonic.

4.5.2 Test Procedures

1. The testing follows FCC KDB 971168 D01 v02r02 Section 5.8 and ANSI / TIA-603-D-2010 Section 2.2.12.
2. The EUT was placed on a rotatable wooden table 0.8 meters above the ground.
3. The EUT was set 3 meters from the receiving antenna, which was mounted on the antenna tower.
4. The table was rotated 360 degrees to determine the position of the highest spurious emission.
5. The height of the receiving antenna is varied between one meter and four meters to search for the maximum spurious emission for both horizontal and vertical polarizations.
6. Make the measurement with the spectrum analyzer's RBW = 1MHz, VBW = 3MHz, taking record of maximum spurious emission.
7. A horn antenna was substituted in place of the EUT and was driven by a signal generator.
8. Tune the output power of signal generator to the same emission level with EUT maximum spurious emission.
9. Taking the record of output power at antenna port.
10. Repeat step 7 to step 8 for another polarization.
11. $EIRP \text{ (dBm)} = S.G. \text{ Power} - Tx \text{ Cable Loss} + Tx \text{ Antenna Gain}$
12. $ERP \text{ (dBm)} = EIRP - 2.15$
13. The RF fundamental frequency should be excluded against the limit line in the operating frequency band.
14. The limit line is derived from $43 + 10\log(P)$ dB below the transmitter power P(Watts)
 $= P(W) - [43 + 10\log(P)] \text{ (dB)}$
 $= [30 + 10\log(P)] \text{ (dBm)} - [43 + 10\log(P)] \text{ (dB)}$
 $= -13\text{dBm}.$



5 List of Measuring Equipment

Instrument	Manufacturer	Model No.	Serial No.	Characteristics	Calibration Date	Test Date	Due Date	Remark
Spectrum Analyzer	R&S	FSP30	101400	9kHz~30GHz	Jan. 28, 2015	Dec. 10, 2015	Jan. 27, 2016	Conducted (TH01-SZ)
Thermal Chamber	Ten Billion Hongzhangroup	LP-150U	H2014081803	-40~+150°C	Aug. 07, 2015	Dec. 10, 2015	Aug. 06, 2016	Conducted (TH01-SZ)
EMI Test Receiver&SA	Agilent Technologies	N9038A	MY52260185	20Hz~26.5GHz	May 26, 2015	Dec. 16, 2015	May 25, 2016	Radiation (03CH01-SZ)
Spectrum Analyzer	KEYSIGHT	N9010A	MY55150213	10Hz~44GHz;Max 30dBm	Jun. 07, 2015	Dec. 16, 2015	Jun. 06, 2016	Radiation (03CH01-SZ)
Bilog Antenna	TeseQ	CBL6112D	23188	30MHz-2GHz	Oct. 17, 2015	Dec. 16, 2015	Oct. 16, 2016	Radiation (03CH01-SZ)
Double Ridge Horn Antenna	ETS Lindgren	3117	00119436	1GHz~18GHz	Oct. 17, 2015	Dec. 16, 2015	Oct. 16, 2016	Radiation (03CH01-SZ)
Double Ridge Horn Antenna	SCHWARZBECK	BBHA 9120D	9120D-1285	1GHz~18GHz	Jan. 20, 2015	Dec. 16, 2015	Jan. 19, 2016	Radiation (03CH01-SZ)
SHF-EHF Horn	com-power	AH-840	101071	18Ghz-40GHz	Aug.19, 2015	Dec. 16, 2015	Aug. 18, 2016	Radiation (03CH01-SZ)
Amplifier	ADVANTEST	BB525C	E9007003	9kHz ~3000MHz / 30 dB	Jan. 28, 2015	Dec. 16, 2015	Jan. 27, 2016	Radiation (03CH01-SZ)
Amplifier	Agilent Technologies	83017A	MY39501302	500MHz~26.5GHz	Jan. 28, 2015	Dec. 16, 2015	Jan. 27, 2016	Radiation (03CH01-SZ)
Amplifier	Yiai	AV3860B	04030	2GHz~26.5GHz	May 05, 2015	Dec. 16, 2015	May 04, 2016	Radiation (03CH01-SZ)
AC Power Source	Chroma	61601	616010001985	N/A	NCR	Dec. 16, 2015	NCR	Radiation (03CH01-SZ)
Turn Table	EM	EM1000	N/A	0~360 degree	NCR	Dec. 16, 2015	NCR	Radiation (03CH01-SZ)
Antenna Mast	EM	EM1000	N/A	1 m~4 m	NCR	Dec. 16, 2015	NCR	Radiation (03CH01-SZ)



6 Uncertainty of Evaluation

Uncertainty of Radiated Emission Measurement (30 MHz ~ 1000 MHz)

Measuring Uncertainty for a Level of Confidence of 95% ($U = 2Uc(y)$)	4.8dB
---	-------



Appendix A. Test Results of Conducted Test

Conducted Output Power(Average power)

Conducted Power (*Unit: dBm)						
Band	GSM850			GSM1900		
Channel	128	189	251	512	661	810
Frequency	824.2	836.4	848.8	1850.2	1880.0	1909.8
GPRS class 8	32.87	32.75	32.63	29.45	29.40	29.62
GPRS class 10	31.81	31.70	31.59	28.51	28.44	28.75
GPRS class 11	30.06	29.94	29.84	26.64	26.67	26.94
GPRS class 12	29.42	29.29	29.16	25.76	25.79	26.03



Peak-to-Average Ratio

Mode	GSM850	Limit: 13dB
Mod.	GPRS class 8	Result
Lowest CH	0.24	PASS
Middle CH	0.28	
Highest CH	0.24	

Mode	GSM1900	Limit: 13dB
Mod.	GPRS class 8	Result
Lowest CH	0.28	PASS
Middle CH	0.28	
Highest CH	0.28	



GSM850 (GPRS class 8)	GSM1900 (GPRS class 8)
<p style="text-align: center;">Lowest Channel</p> <p style="text-align: center;">Date: 10.DEC.2015 16:56:54</p>	<p style="text-align: center;">Lowest Channel</p> <p style="text-align: center;">Date: 10.DEC.2015 17:22:01</p>
<p style="text-align: center;">Middle Channel</p> <p style="text-align: center;">Date: 10.DEC.2015 16:57:08</p>	<p style="text-align: center;">Middle Channel</p> <p style="text-align: center;">Date: 10.DEC.2015 17:22:28</p>
<p style="text-align: center;">Highest Channel</p> <p style="text-align: center;">Date: 10.DEC.2015 16:57:20</p>	<p style="text-align: center;">Highest Channel</p> <p style="text-align: center;">Date: 10.DEC.2015 17:22:51</p>



26dB Bandwidth

Mode	GSM850
Mod.	GPRS class 8
Lowest CH	0.305
Middle CH	0.315
Highest CH	0.314

Mode	GSM1900
Mod.	GPRS class 8
Lowest CH	0.305
Middle CH	0.315
Highest CH	0.318

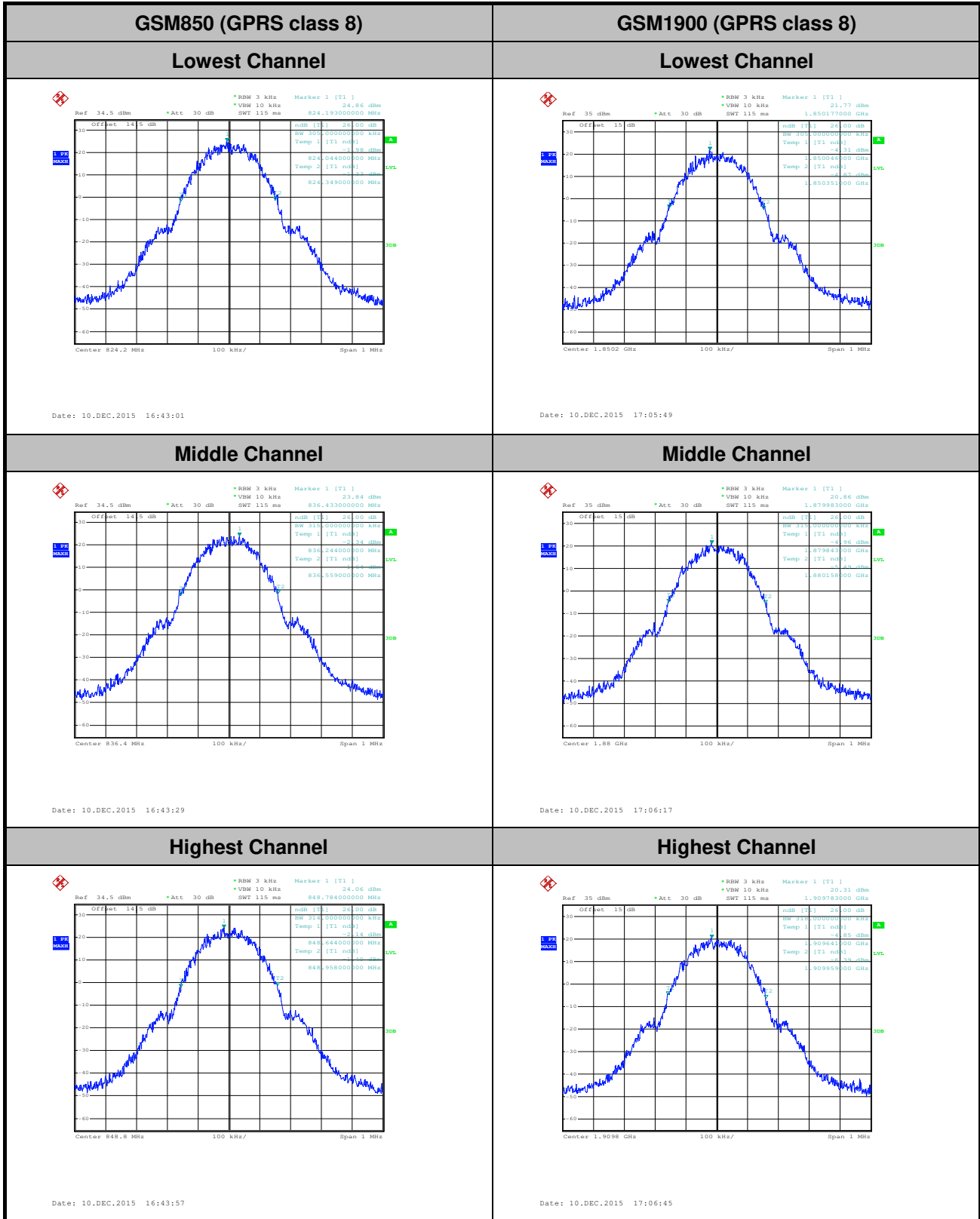



Occupied Bandwidth

Mode	GSM850
Mod.	GPRS class 8
Lowest CH	0.244
Middle CH	0.244
Highest CH	0.243

Mode	GSM1900
Mod.	GPRS class 8
Lowest CH	0.240
Middle CH	0.247
Highest CH	0.242

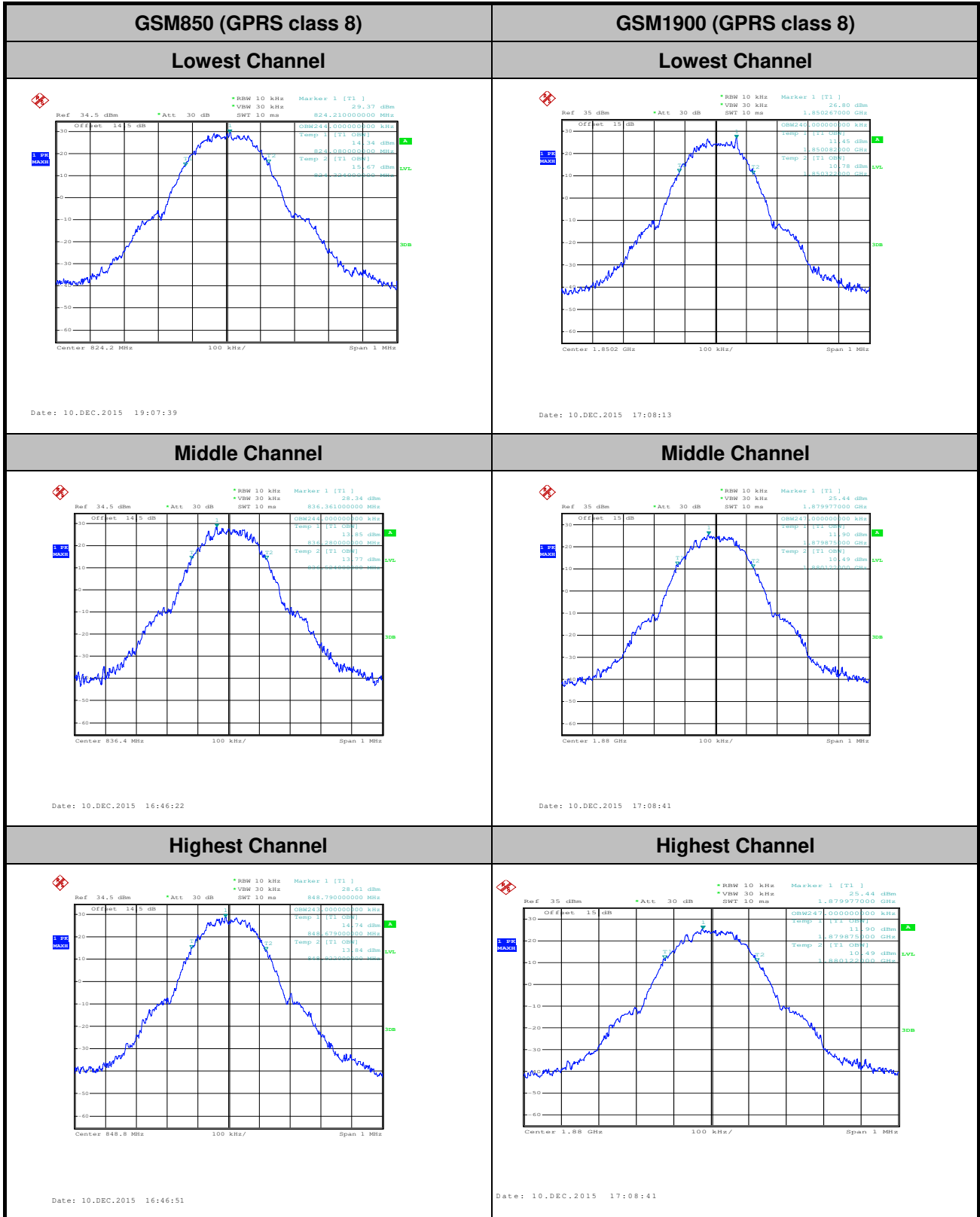



Conducted Band Edge

GSM850 (GPRS class 8)

Lowest Band Edge

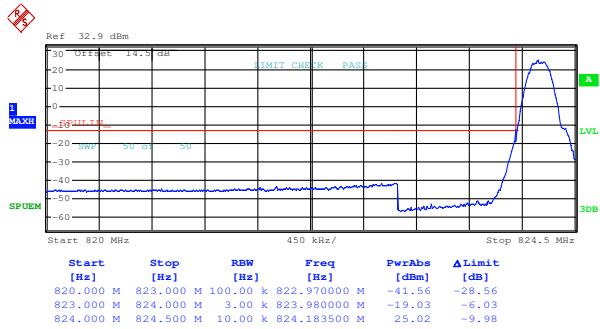

Date: 10.DEC.2015 16:48:53

Highest Band Edge

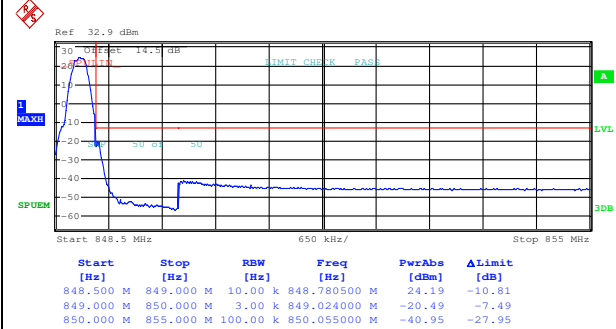

Date: 10.DEC.2015 16:50:20



GSM1900 (GPRS class 8)

Lowest Band Edge

Highest Band Edge

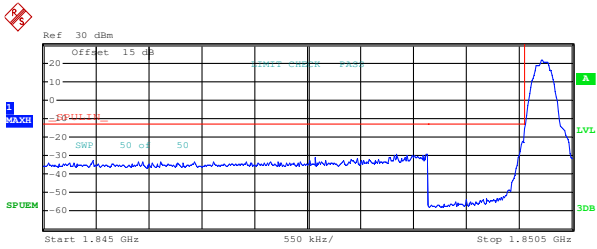

Start [Hz]	Stop [Hz]	RBW [Hz]	Freq [Hz]	PwrAbs [dBm]	ΔLimit [dB]
1.845 G	1.849 G	1.00 M	1.849000 G	-29.07	-16.07
1.849 G	1.850 G	3.00 k	1.849984 G	-22.19	-9.19
1.850 G	1.851 G	10.00 k	1.850177 G	21.31	-13.69

Date: 10.DEC.2015 17:11:23

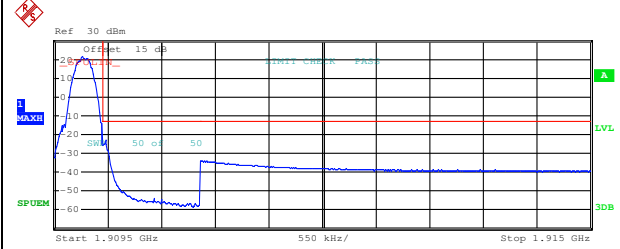

Start [Hz]	Stop [Hz]	RBW [Hz]	Freq [Hz]	PwrAbs [dBm]	ΔLimit [dB]
1.910 G	1.910 G	10.00 k	1.909782 G	21.24	-13.76
1.910 G	1.911 G	3.00 k	1.910024 G	-22.78	-9.78
1.911 G	1.915 G	1.00 M	1.911016 G	-34.10	-21.10

Date: 10.DEC.2015 17:12:51

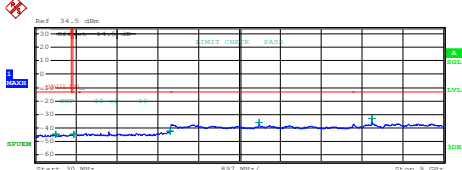
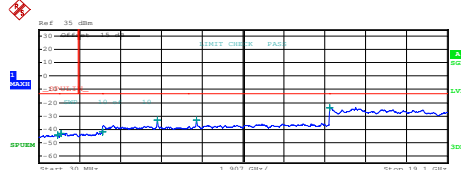
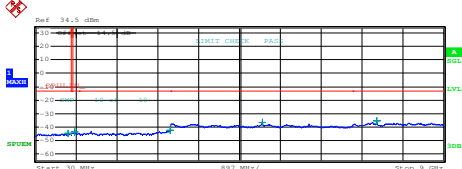
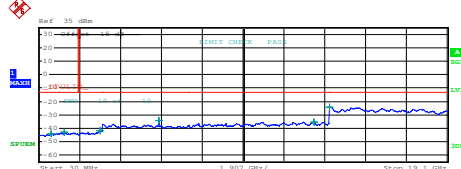
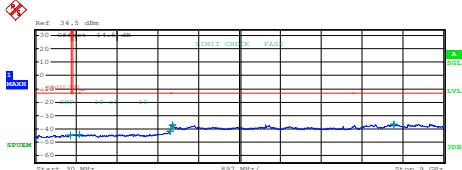
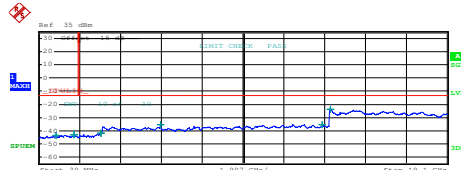

Conducted Spurious Emission

GSM850 (GPRS class 8)	GSM1900 (GPRS class 8)																																																																														
Lowest Channel	Lowest Channel																																																																														
 <table border="1" data-bbox="239 660 654 739"> <thead> <tr> <th>Start [Hz]</th> <th>Stop [Hz]</th> <th>RBW [Hz]</th> <th>Freq [Hz]</th> <th>PwrAbs [dBm]</th> <th>ΔLimit [dB]</th> </tr> </thead> <tbody> <tr> <td>30.000 M</td> <td>820.000 M</td> <td>1.00 M</td> <td>480.497500 M</td> <td>-45.00</td> <td>-32.00</td> </tr> <tr> <td>855.000 M</td> <td>1.000 G</td> <td>1.00 M</td> <td>880.121252 M</td> <td>-44.74</td> <td>-31.74</td> </tr> <tr> <td>1.000 G</td> <td>3.000 G</td> <td>1.00 M</td> <td>2.990500 G</td> <td>-42.50</td> <td>-29.50</td> </tr> <tr> <td>3.000 G</td> <td>7.000 G</td> <td>1.00 M</td> <td>4.945000 G</td> <td>-35.86</td> <td>-22.86</td> </tr> <tr> <td>7.000 G</td> <td>9.000 G</td> <td>1.00 M</td> <td>7.417500 G</td> <td>-32.97</td> <td>-19.97</td> </tr> </tbody> </table> <p>Date: 10.DEC.2015 16:54:56</p>	Start [Hz]	Stop [Hz]	RBW [Hz]	Freq [Hz]	PwrAbs [dBm]	ΔLimit [dB]	30.000 M	820.000 M	1.00 M	480.497500 M	-45.00	-32.00	855.000 M	1.000 G	1.00 M	880.121252 M	-44.74	-31.74	1.000 G	3.000 G	1.00 M	2.990500 G	-42.50	-29.50	3.000 G	7.000 G	1.00 M	4.945000 G	-35.86	-22.86	7.000 G	9.000 G	1.00 M	7.417500 G	-32.97	-19.97	 <table border="1" data-bbox="885 660 1300 739"> <thead> <tr> <th>Start [Hz]</th> <th>Stop [Hz]</th> <th>RBW [Hz]</th> <th>Freq [Hz]</th> <th>PwrAbs [dBm]</th> <th>ΔLimit [dB]</th> </tr> </thead> <tbody> <tr> <td>30.000 M</td> <td>1.000 G</td> <td>1.00 M</td> <td>910.032500 M</td> <td>-45.29</td> <td>-31.29</td> </tr> <tr> <td>1.000 G</td> <td>1.845 G</td> <td>1.00 M</td> <td>1.066544 G</td> <td>-43.11</td> <td>-30.11</td> </tr> <tr> <td>1.915 G</td> <td>3.000 G</td> <td>1.00 M</td> <td>2.993761 G</td> <td>-41.89</td> <td>-28.89</td> </tr> <tr> <td>3.000 G</td> <td>7.000 G</td> <td>1.00 M</td> <td>5.551000 G</td> <td>-33.05</td> <td>-20.05</td> </tr> <tr> <td>7.000 G</td> <td>13.600 G</td> <td>1.00 M</td> <td>7.400125 G</td> <td>-32.88</td> <td>-19.88</td> </tr> <tr> <td>13.600 G</td> <td>19.100 G</td> <td>1.00 M</td> <td>13.623375 G</td> <td>-23.98</td> <td>-10.98</td> </tr> </tbody> </table> <p>Date: 10.DEC.2015 17:14:51</p>	Start [Hz]	Stop [Hz]	RBW [Hz]	Freq [Hz]	PwrAbs [dBm]	ΔLimit [dB]	30.000 M	1.000 G	1.00 M	910.032500 M	-45.29	-31.29	1.000 G	1.845 G	1.00 M	1.066544 G	-43.11	-30.11	1.915 G	3.000 G	1.00 M	2.993761 G	-41.89	-28.89	3.000 G	7.000 G	1.00 M	5.551000 G	-33.05	-20.05	7.000 G	13.600 G	1.00 M	7.400125 G	-32.88	-19.88	13.600 G	19.100 G	1.00 M	13.623375 G	-23.98	-10.98
Start [Hz]	Stop [Hz]	RBW [Hz]	Freq [Hz]	PwrAbs [dBm]	ΔLimit [dB]																																																																										
30.000 M	820.000 M	1.00 M	480.497500 M	-45.00	-32.00																																																																										
855.000 M	1.000 G	1.00 M	880.121252 M	-44.74	-31.74																																																																										
1.000 G	3.000 G	1.00 M	2.990500 G	-42.50	-29.50																																																																										
3.000 G	7.000 G	1.00 M	4.945000 G	-35.86	-22.86																																																																										
7.000 G	9.000 G	1.00 M	7.417500 G	-32.97	-19.97																																																																										
Start [Hz]	Stop [Hz]	RBW [Hz]	Freq [Hz]	PwrAbs [dBm]	ΔLimit [dB]																																																																										
30.000 M	1.000 G	1.00 M	910.032500 M	-45.29	-31.29																																																																										
1.000 G	1.845 G	1.00 M	1.066544 G	-43.11	-30.11																																																																										
1.915 G	3.000 G	1.00 M	2.993761 G	-41.89	-28.89																																																																										
3.000 G	7.000 G	1.00 M	5.551000 G	-33.05	-20.05																																																																										
7.000 G	13.600 G	1.00 M	7.400125 G	-32.88	-19.88																																																																										
13.600 G	19.100 G	1.00 M	13.623375 G	-23.98	-10.98																																																																										
Middle Channel	Middle Channel																																																																														
 <table border="1" data-bbox="239 1180 654 1258"> <thead> <tr> <th>Start [Hz]</th> <th>Stop [Hz]</th> <th>RBW [Hz]</th> <th>Freq [Hz]</th> <th>PwrAbs [dBm]</th> <th>ΔLimit [dB]</th> </tr> </thead> <tbody> <tr> <td>30.000 M</td> <td>820.000 M</td> <td>1.00 M</td> <td>753.442500 M</td> <td>-44.75</td> <td>-31.75</td> </tr> <tr> <td>855.000 M</td> <td>1.000 G</td> <td>1.00 M</td> <td>885.832500 M</td> <td>-43.29</td> <td>-30.29</td> </tr> <tr> <td>1.000 G</td> <td>3.000 G</td> <td>1.00 M</td> <td>2.988000 G</td> <td>-42.59</td> <td>-29.59</td> </tr> <tr> <td>3.000 G</td> <td>7.000 G</td> <td>1.00 M</td> <td>5.019000 G</td> <td>-36.53</td> <td>-23.53</td> </tr> <tr> <td>7.000 G</td> <td>9.000 G</td> <td>1.00 M</td> <td>7.328000 G</td> <td>-35.55</td> <td>-22.55</td> </tr> </tbody> </table> <p>Date: 10.DEC.2015 16:55:26</p>	Start [Hz]	Stop [Hz]	RBW [Hz]	Freq [Hz]	PwrAbs [dBm]	ΔLimit [dB]	30.000 M	820.000 M	1.00 M	753.442500 M	-44.75	-31.75	855.000 M	1.000 G	1.00 M	885.832500 M	-43.29	-30.29	1.000 G	3.000 G	1.00 M	2.988000 G	-42.59	-29.59	3.000 G	7.000 G	1.00 M	5.019000 G	-36.53	-23.53	7.000 G	9.000 G	1.00 M	7.328000 G	-35.55	-22.55	 <table border="1" data-bbox="885 1180 1300 1258"> <thead> <tr> <th>Start [Hz]</th> <th>Stop [Hz]</th> <th>RBW [Hz]</th> <th>Freq [Hz]</th> <th>PwrAbs [dBm]</th> <th>ΔLimit [dB]</th> </tr> </thead> <tbody> <tr> <td>30.000 M</td> <td>1.000 G</td> <td>1.00 M</td> <td>583.142500 M</td> <td>-44.01</td> <td>-31.01</td> </tr> <tr> <td>1.000 G</td> <td>1.845 G</td> <td>1.00 M</td> <td>1.221813 G</td> <td>-43.02</td> <td>-30.02</td> </tr> <tr> <td>1.915 G</td> <td>3.000 G</td> <td>1.00 M</td> <td>2.876310 G</td> <td>-41.76</td> <td>-28.76</td> </tr> <tr> <td>3.000 G</td> <td>7.000 G</td> <td>1.00 M</td> <td>5.640000 G</td> <td>-34.33</td> <td>-21.33</td> </tr> <tr> <td>7.000 G</td> <td>13.600 G</td> <td>1.00 M</td> <td>12.852250 G</td> <td>-35.51</td> <td>-22.51</td> </tr> <tr> <td>13.600 G</td> <td>19.100 G</td> <td>1.00 M</td> <td>13.607563 G</td> <td>-24.11</td> <td>-11.11</td> </tr> </tbody> </table> <p>Date: 10.DEC.2015 17:15:21</p>	Start [Hz]	Stop [Hz]	RBW [Hz]	Freq [Hz]	PwrAbs [dBm]	ΔLimit [dB]	30.000 M	1.000 G	1.00 M	583.142500 M	-44.01	-31.01	1.000 G	1.845 G	1.00 M	1.221813 G	-43.02	-30.02	1.915 G	3.000 G	1.00 M	2.876310 G	-41.76	-28.76	3.000 G	7.000 G	1.00 M	5.640000 G	-34.33	-21.33	7.000 G	13.600 G	1.00 M	12.852250 G	-35.51	-22.51	13.600 G	19.100 G	1.00 M	13.607563 G	-24.11	-11.11
Start [Hz]	Stop [Hz]	RBW [Hz]	Freq [Hz]	PwrAbs [dBm]	ΔLimit [dB]																																																																										
30.000 M	820.000 M	1.00 M	753.442500 M	-44.75	-31.75																																																																										
855.000 M	1.000 G	1.00 M	885.832500 M	-43.29	-30.29																																																																										
1.000 G	3.000 G	1.00 M	2.988000 G	-42.59	-29.59																																																																										
3.000 G	7.000 G	1.00 M	5.019000 G	-36.53	-23.53																																																																										
7.000 G	9.000 G	1.00 M	7.328000 G	-35.55	-22.55																																																																										
Start [Hz]	Stop [Hz]	RBW [Hz]	Freq [Hz]	PwrAbs [dBm]	ΔLimit [dB]																																																																										
30.000 M	1.000 G	1.00 M	583.142500 M	-44.01	-31.01																																																																										
1.000 G	1.845 G	1.00 M	1.221813 G	-43.02	-30.02																																																																										
1.915 G	3.000 G	1.00 M	2.876310 G	-41.76	-28.76																																																																										
3.000 G	7.000 G	1.00 M	5.640000 G	-34.33	-21.33																																																																										
7.000 G	13.600 G	1.00 M	12.852250 G	-35.51	-22.51																																																																										
13.600 G	19.100 G	1.00 M	13.607563 G	-24.11	-11.11																																																																										
Highest Channel	Highest Channel																																																																														
 <table border="1" data-bbox="239 1700 654 1778"> <thead> <tr> <th>Start [Hz]</th> <th>Stop [Hz]</th> <th>RBW [Hz]</th> <th>Freq [Hz]</th> <th>PwrAbs [dBm]</th> <th>ΔLimit [dB]</th> </tr> </thead> <tbody> <tr> <td>30.000 M</td> <td>820.000 M</td> <td>1.00 M</td> <td>804.030000 M</td> <td>-44.50</td> <td>-31.50</td> </tr> <tr> <td>855.000 M</td> <td>1.000 G</td> <td>1.00 M</td> <td>994.598760 M</td> <td>-44.34</td> <td>-31.34</td> </tr> <tr> <td>1.000 G</td> <td>3.000 G</td> <td>1.00 M</td> <td>2.996500 G</td> <td>-41.84</td> <td>-28.84</td> </tr> <tr> <td>3.000 G</td> <td>7.000 G</td> <td>1.00 M</td> <td>5.042000 G</td> <td>-37.29</td> <td>-24.29</td> </tr> <tr> <td>7.000 G</td> <td>9.000 G</td> <td>1.00 M</td> <td>7.902500 G</td> <td>-36.51</td> <td>-23.51</td> </tr> </tbody> </table> <p>Date: 10.DEC.2015 16:55:56</p>	Start [Hz]	Stop [Hz]	RBW [Hz]	Freq [Hz]	PwrAbs [dBm]	ΔLimit [dB]	30.000 M	820.000 M	1.00 M	804.030000 M	-44.50	-31.50	855.000 M	1.000 G	1.00 M	994.598760 M	-44.34	-31.34	1.000 G	3.000 G	1.00 M	2.996500 G	-41.84	-28.84	3.000 G	7.000 G	1.00 M	5.042000 G	-37.29	-24.29	7.000 G	9.000 G	1.00 M	7.902500 G	-36.51	-23.51	 <table border="1" data-bbox="885 1700 1300 1778"> <thead> <tr> <th>Start [Hz]</th> <th>Stop [Hz]</th> <th>RBW [Hz]</th> <th>Freq [Hz]</th> <th>PwrAbs [dBm]</th> <th>ΔLimit [dB]</th> </tr> </thead> <tbody> <tr> <td>30.000 M</td> <td>1.000 G</td> <td>1.00 M</td> <td>823.217500 M</td> <td>-43.89</td> <td>-30.89</td> </tr> <tr> <td>1.000 G</td> <td>1.845 G</td> <td>1.00 M</td> <td>1.068239 G</td> <td>-43.25</td> <td>-30.25</td> </tr> <tr> <td>1.915 G</td> <td>3.000 G</td> <td>1.00 M</td> <td>2.910759 G</td> <td>-41.80</td> <td>-28.80</td> </tr> <tr> <td>3.000 G</td> <td>7.000 G</td> <td>1.00 M</td> <td>5.730000 G</td> <td>-35.31</td> <td>-22.31</td> </tr> <tr> <td>7.000 G</td> <td>13.600 G</td> <td>1.00 M</td> <td>13.272475 G</td> <td>-35.44</td> <td>-22.44</td> </tr> <tr> <td>13.600 G</td> <td>19.100 G</td> <td>1.00 M</td> <td>13.633625 G</td> <td>-23.84</td> <td>-10.84</td> </tr> </tbody> </table> <p>Date: 10.DEC.2015 17:15:51</p>	Start [Hz]	Stop [Hz]	RBW [Hz]	Freq [Hz]	PwrAbs [dBm]	ΔLimit [dB]	30.000 M	1.000 G	1.00 M	823.217500 M	-43.89	-30.89	1.000 G	1.845 G	1.00 M	1.068239 G	-43.25	-30.25	1.915 G	3.000 G	1.00 M	2.910759 G	-41.80	-28.80	3.000 G	7.000 G	1.00 M	5.730000 G	-35.31	-22.31	7.000 G	13.600 G	1.00 M	13.272475 G	-35.44	-22.44	13.600 G	19.100 G	1.00 M	13.633625 G	-23.84	-10.84
Start [Hz]	Stop [Hz]	RBW [Hz]	Freq [Hz]	PwrAbs [dBm]	ΔLimit [dB]																																																																										
30.000 M	820.000 M	1.00 M	804.030000 M	-44.50	-31.50																																																																										
855.000 M	1.000 G	1.00 M	994.598760 M	-44.34	-31.34																																																																										
1.000 G	3.000 G	1.00 M	2.996500 G	-41.84	-28.84																																																																										
3.000 G	7.000 G	1.00 M	5.042000 G	-37.29	-24.29																																																																										
7.000 G	9.000 G	1.00 M	7.902500 G	-36.51	-23.51																																																																										
Start [Hz]	Stop [Hz]	RBW [Hz]	Freq [Hz]	PwrAbs [dBm]	ΔLimit [dB]																																																																										
30.000 M	1.000 G	1.00 M	823.217500 M	-43.89	-30.89																																																																										
1.000 G	1.845 G	1.00 M	1.068239 G	-43.25	-30.25																																																																										
1.915 G	3.000 G	1.00 M	2.910759 G	-41.80	-28.80																																																																										
3.000 G	7.000 G	1.00 M	5.730000 G	-35.31	-22.31																																																																										
7.000 G	13.600 G	1.00 M	13.272475 G	-35.44	-22.44																																																																										
13.600 G	19.100 G	1.00 M	13.633625 G	-23.84	-10.84																																																																										



Frequency Stability

Test Conditions	Middle Channel	GSM850 (GPRS class 8)	Limit 2.5ppm
Temperature (°C)	Voltage (Volt)	Deviation (ppm)	Result
50	Normal Voltage	0.0167	PASS
40	Normal Voltage	0.0096	
30	Normal Voltage	0.0048	
20(Ref.)	Normal Voltage	0.0000	
10	Normal Voltage	0.0036	
0	Normal Voltage	0.0072	
-10	Normal Voltage	0.0108	
-20	Normal Voltage	0.0143	
-30	Normal Voltage	0.0179	
20	Maximum Voltage	0.0012	
20	Normal Voltage	0.0000	
20	Battery End Point	0.0024	



Test Conditions	Middle Channel	GSM1900 (GPRS class 8)	Limit Note 2.
Temperature (°C)	Voltage (Volt)	Deviation (ppm)	Result
50	Normal Voltage	0.0096	PASS
40	Normal Voltage	0.0060	
30	Normal Voltage	0.0024	
20(Ref.)	Normal Voltage	0.0000	
10	Normal Voltage	0.0024	
0	Normal Voltage	0.0048	
-10	Normal Voltage	0.0072	
-20	Normal Voltage	0.0096	
-30	Normal Voltage	0.0120	
20	Maximum Voltage	0.0012	
20	Normal Voltage	0.0000	
20	Battery End Point	0.0012	

Note:

1. Normal Voltage = 3.7V. ; Battery End Point (BEP) = 3.5 V. ; Maximum Voltage =4.2 V
2. The frequency fundamental emissions stay within the authorized frequency block based on the frequency deviation measured is small.



Appendix B. Test Results of Radiated Test

ERP/EIRP

Channel	Mode	Horizontal		Vertical	
		ERP(dBm)	ERP(W)	ERP(dBm)	ERP(W)
Lowest	GSM850 GPRS class 8	29.10	0.8128	27.14	0.5176
Middle		28.93	0.7816	26.81	0.4797
Highest		28.75	0.7499	27.12	0.5152
Limit	ERP < 7W	Result		PASS	

Channel	Mode	Horizontal		Vertical	
		EIRP(dBm)	EIRP(W)	EIRP(dBm)	EIRP(W)
Lowest	GSM1900 GPRS class 8	27.81	0.6039	27.00	0.5012
Middle		29.44	0.8790	27.85	0.6095
Highest		28.36	0.6855	28.24	0.6668
Limit	EIRP < 2W	Result		PASS	



Radiated Spurious Emission

GSM850 (GPRS class 8)									
Channel	Frequency (MHz)	ERP (dBm)	Limit (dBm)	Over Limit (dB)	SPA Reading (dBm)	S.G. Power (dBm)	TX Cable loss (dB)	TX Antenna Gain (dBi)	Polarization (H/V)
Lowest	1648.4	-35.53	-13	-22.53	-47.24	-42.21	0.57	9.40	H
	2472.6	-31.60	-13	-18.60	-48.84	-39.31	0.74	10.60	H
	3296.8	-36.86	-13	-23.86	-55.93	-46.46	0.85	12.60	H
	4121	-31.47	-13	-18.47	-53.08	-41.03	0.89	12.60	H
	4945.2	-34.72	-13	-21.72	-57.35	-44.33	0.94	12.70	H
	5769.4	-41.29	-13	-28.29	-62.89	-51.03	1.11	13.00	H
	6593.6	-34.08	-13	-21.08	-58.25	-42.41	1.22	11.70	H
	7417.8	-37.75	-13	-24.75	-62.21	-45.21	1.69	11.30	H
	8242	-36.48	-13	-23.48	-63.15	-44.00	1.63	11.30	H
	1648.4	-33.22	-13	-20.22	-44.28	-39.90	0.57	9.40	V
	2472.6	-29.40	-13	-16.40	-47.00	-37.11	0.74	10.60	V
	3296.8	-37.06	-13	-24.06	-56.14	-46.66	0.85	12.60	V
	4121	-31.79	-13	-18.79	-53.47	-41.35	0.89	12.60	V
	4945.2	-36.31	-13	-23.31	-58.59	-45.92	0.94	12.70	V
	5769.4	-39.75	-13	-26.75	-61.69	-49.49	1.11	13.00	V
	6593.6	-33.62	-13	-20.62	-57.96	-41.95	1.22	11.70	V
	7417.8	-37.61	-13	-24.61	-61.79	-45.07	1.69	11.30	V
8242	-35.59	-13	-22.59	-62.21	-43.11	1.63	11.30	V	
Middle	1672	-47.20	-13	-34.20	-57.08	-53.88	0.57	9.40	H
	2510	-27.09	-13	-14.09	-44.45	-34.80	0.74	10.60	H
	3346	-34.55	-13	-21.55	-54.06	-44.15	0.85	12.60	H
	4182	-32.97	-13	-19.97	-54.49	-42.53	0.89	12.60	H
	5018	-31.48	-13	-18.48	-54.79	-41.09	0.94	12.70	H
	5854	-39.53	-13	-26.53	-61.46	-49.27	1.11	13.00	H
	6691	-34.97	-13	-21.97	-58.96	-43.30	1.22	11.70	H
	7528	-42.30	-13	-29.30	-66.76	-49.76	1.69	11.30	H
	8364	-43.92	-13	-30.92	-70.59	-51.44	1.63	11.30	H
	1672	-39.26	-13	-26.26	-49.94	-45.94	0.57	9.40	V
	2510	-21.81	-13	-8.81	-39.54	-29.52	0.74	10.60	V
	3346	-34.95	-13	-21.95	-54.37	-44.55	0.85	12.60	V
	4182	-35.81	-13	-22.81	-56.76	-45.37	0.89	12.60	V
	5018	-37.52	-13	-24.52	-59.64	-47.13	0.94	12.70	V
	5854	-41.82	-13	-28.82	-63.02	-51.56	1.11	13.00	V
	6691	-31.37	-13	-18.37	-56.28	-39.70	1.22	11.70	V
	7528	-40.91	-13	-27.91	-65.09	-48.37	1.69	11.30	V
8364	-43.06	-13	-30.06	-69.49	-50.58	1.63	11.30	V	



Highest	1697.6	-45.58	-13	-32.58	-55.83	-52.26	0.57	9.40	H
	2546.4	-18.31	-13	-5.31	-35.92	-26.02	0.74	10.60	H
	3395.2	-41.87	-13	-28.87	-59.90	-51.47	0.85	12.60	H
	4244	-30.68	-13	-17.68	-52.38	-40.24	0.89	12.60	H
	5092.8	-31.80	-13	-18.80	-55.09	-41.41	0.94	12.70	H
	5941.6	-41.21	-13	-28.21	-62.78	-50.95	1.11	13.00	H
	6790.4	-34.03	-13	-21.03	-58.21	-42.36	1.22	11.70	H
	7639.2	-44.13	-13	-31.13	-68.59	-51.59	1.69	11.30	H
	8488	-47.81	-13	-34.81	-74.48	-55.33	1.63	11.30	H
	1697.6	-45.14	-13	-32.14	-54.93	-51.82	0.57	9.40	V
	2546.4	-16.29	-13	-3.29	-33.99	-24.00	0.74	10.60	V
	3395.2	-36.36	-13	-23.36	-55.65	-45.96	0.85	12.60	V
	4244	-34.44	-13	-21.44	-55.57	-44.00	0.89	12.60	V
	5092.8	-36.50	-13	-23.50	-58.76	-46.11	0.94	12.70	V
	5941.6	-39.93	-13	-26.93	-61.82	-49.67	1.11	13.00	V
	6790.4	-31.62	-13	-18.62	-56.52	-39.95	1.22	11.70	V
	7639.2	-43.95	-13	-30.95	-68.13	-51.41	1.69	11.30	V
	8488	-45.91	-13	-32.91	-72.34	-53.43	1.63	11.30	V

Remark: Spurious emissions within 30-1000MHz were found more than 20dB below limit line.



GSM1900 (GPRS class 8)									
Channel	Frequency (MHz)	EIRP (dBm)	Limit (dBm)	Over Limit (dB)	SPA Reading (dBm)	S.G. Power (dBm)	TX Cable loss (dB)	TX Antenna Gain (dBi)	Polarization (H/V)
Lowest	3700.4	-35.63	-13	-22.63	-58.14	-47.36	0.87	12.60	H
	5550.6	-13.69	-13	-0.69	-40.23	-25.72	1.07	13.10	H
	7400.8	-25.83	-13	-12.83	-55.17	-35.44	1.69	11.30	H
	9251	-28.43	-13	-15.43	-61.04	-38.50	1.83	11.90	H
	3700.4	-35.26	-13	-22.26	-58.09	-46.99	0.87	12.6	V
	5550.6	-14.76	-13	-1.76	-41.59	-26.79	1.07	13.1	V
	7400.8	-25.28	-13	-12.28	-54.14	-34.71	1.87	11.3	V
	9251	-28.52	-13	-15.52	-59.94	-38.59	1.83	11.9	V
Middle	3760	-37.98	-13	-24.98	-59.79	-49.71	0.87	12.60	H
	5640	-18.00	-13	-5.00	-44.46	-30.03	1.07	13.10	H
	7520	-26.47	-13	-13.47	-55.70	-36.08	1.69	11.30	H
	9400	-33.84	-13	-20.84	-64.24	-43.91	1.83	11.90	H
	3760	-38.11	-13	-25.11	-60.51	-49.84	0.87	12.6	V
	5640	-16.97	-13	-3.97	-43.82	-29.00	1.07	13.1	V
	7520	-28.94	-13	-15.94	-57.33	-38.37	1.87	11.3	V
	9400	-30.62	-13	-17.62	-61.43	-40.69	1.83	11.9	V
Highest	3819.6	-44.00	-13	-31.00	-64.33	-55.73	0.87	12.60	H
	5729.4	-17.69	-13	-4.69	-44.14	-29.72	1.07	13.10	H
	7639.2	-24.68	-13	-11.68	-54.02	-34.29	1.69	11.30	H
	9549	-30.76	-13	-17.76	-62.77	-40.83	1.83	11.90	H
	3819.6	-45.00	-13	-32.00	-66.56	-56.73	0.87	12.6	V
	5729.4	-17.59	-13	-4.59	-44.46	-29.62	1.07	13.1	V
	7639.2	-27.83	-13	-14.83	-56.52	-37.26	1.87	11.3	V
	9549	-28.16	-13	-15.16	-59.69	-38.23	1.83	11.9	V

Remark: Spurious emissions within 30-1000MHz were found more than 20dB below limit line.