

## KNB-65L Specifications

### Mechanical

#### Drawing External Appearance

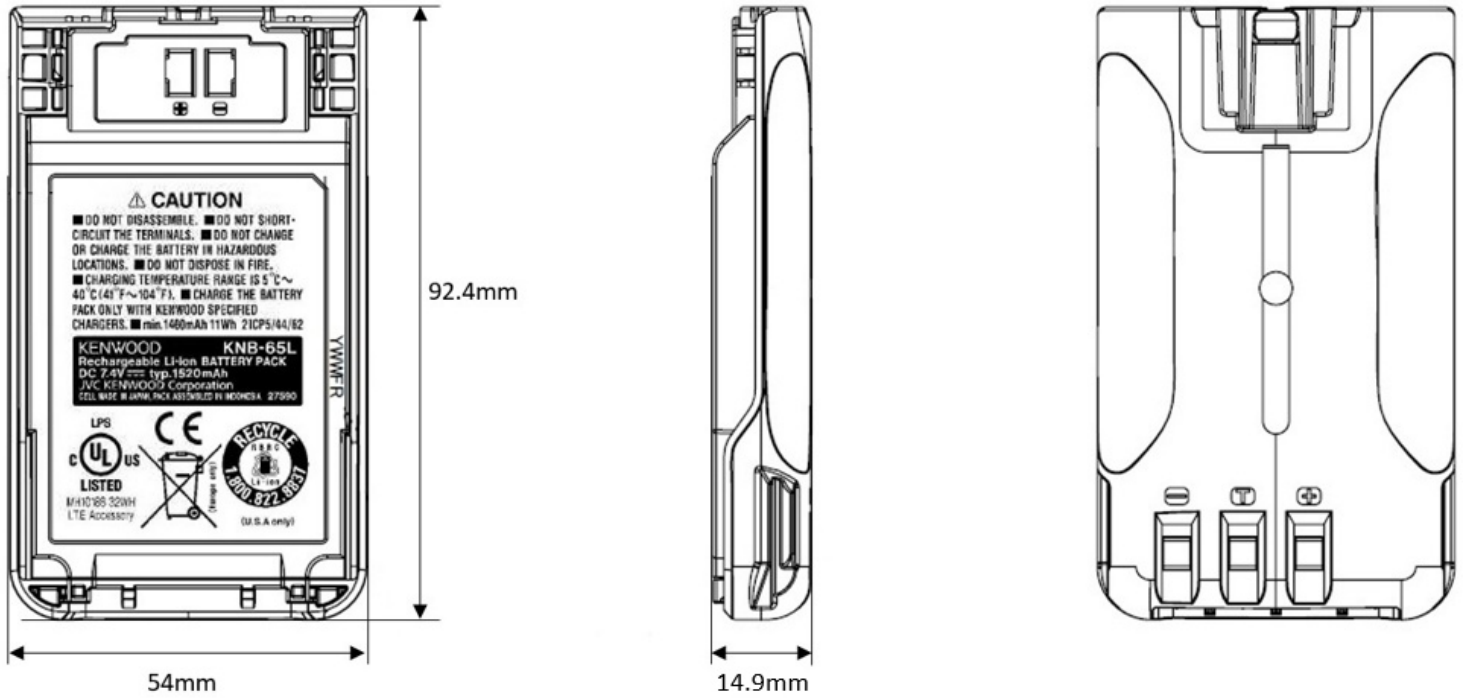

#### External dimensions and Mass of Body

Item	Unit	Body
Width	mm	54
Depth	mm	14.9
Height	mm	92.4
Mass	g	90

## Electrical

Capacity: min. 1460mAh / typ. 1520mAh  
Nominal Voltage: 7.4V (3.7V x 2 cells)

## Circuit Diagram

