



**Compliance Testing, LLC**  
Previously Flom Test Lab  
EMI, EMC, RF Testing Experts Since 1963

toll-free: ( 866 ) 311-3268

fax: ( 480 ) 926-3598

<http://www.ComplianceTesting.com>  
[info@ComplianceTesting.com](mailto:info@ComplianceTesting.com)

Date: December 23, 2010

Applicant: Kenwood USA Corporation  
Communications Division  
3970 Johns Creek Court, Suite 100  
Suwanee, GA 30024

Attention of: Joel E. Berger, Research & Development  
Ph: (678) 474-4722  
Fax: (687) 474 -4731  
E-mail: JBerger@kenwoodusa.com

Equipment: NX-220-K, NX-220-K2, NX-220-K3

FCC ID: ALH430900

FCC Rules: Part 90

Enclosed please find your copy of the Engineering Test Report for which you are subject to the restrictions as listed on the attached summary.

This report may not be reproduced, except in full, without written permission from Compliance Testing, LLC.  
Please retain a copy of this report for your archival purposes.

Once a Telecommunication Certification Body (TCB) issues a Grant the Federal Communication Commission (FCC) has 30 days to review the application and request added information. It is your decision whether or not to market the equipment subject to a possible recall before the end of the 30 days.

If your equipment is still retained by us, it will be returned to you 30 days after approval is achieved.

Our invoice for services has been directed to your Accounts Payable Department.

For any additional information please contact us.

Sincerely,

Compliance Testing



**Compliance Testing, LLC**  
Previously Flom Test Lab  
EMI, EMC, RF Testing Experts Since 1963

toll-free: (866) 311-3268  
fax: (480) 926-3598

<http://www.ComplianceTesting.com>  
[info@ComplianceTesting.com](mailto:info@ComplianceTesting.com)

## Test Report

for

**FCC ID:** ALH430900

**Model:** NX-220-K, NX-220-K2, NX-220-K3

**Description:** VHF Digital Transceiver

to

Federal Communications Commission

Rule Part 90

Date of Report: December 23, 2010

On the Behalf of the Applicant: Kenwood USA Corporation

At the Request of: Kenwood USA Corporation  
Communications Division  
3970 Johns Creek Court, Suite 100  
Suwanee, GA 30024

Attention of: Joel E. Berger, Research & Development  
Ph: (678) 474-4722  
Fax: (687) 474 -4731  
E-mail: [JBerger@kenwoodusa.com](mailto:JBerger@kenwoodusa.com)

By  
Compliance Testing, LLC  
3356 N. San Marcos Place, Suite 107  
Chandler, Arizona 85225-7176  
(866) 311-3268 phone, (480) 926-3598 fax



## Test Report Revision History

Revision	Date	Revised By	Reason for revision
1.0	December 23, 2010	G. Corbin	Original Document
2.0	January 17, 2011	G. Corbin	Added test data for 2 additional antennas KRA-22M3 and KRA-26M3. Also updated the Necessary BW Calculations



**The Applicant has been cautioned as to the following:**

**15.21 Information to the User**

The user's manual or instruction manual for an intentional radiator shall caution the user that changes or modifications not expressly approved by the party responsible for compliance could void the user's authority to operate the equipment.

**15.27(a) Special Accessories**

Equipment marketed to a consumer must be capable of complying with the necessary regulations in the configuration in which the equipment is marketed. Where special accessories, such as shielded cables and/or special connectors are required to enable an unintentional or intentional radiator to comply with the emission limits in this part, the equipment must be marketed with, i.e. shipped and sold with, those special accessories. However, in lieu of shipping or packaging the special accessories with the unintentional or intentional radiator, the responsible party may employ other methods of ensuring that the special accessories are provided to the consumer, without additional charge.

Information detailing any alternative method used to supply the special accessories for a grant of equipment authorization or retained in the verification records, as appropriate. The party responsible for the equipment, as detailed in § 2.909 of this chapter, shall ensure that these special accessories are provided with the equipment. The instruction manual for such devices shall include appropriate instructions on the first page of text concerned with the installation of the device that these special accessories must be used with the device. It is the responsibility of the user to use the needed special accessories supplied with the equipment.



## Testimonial and Statement of Certification

This is to Certify:

1. That the application was prepared either by, or under the direct supervision of, the undersigned.
2. That the technical data supplied with the application was taken under my direction and supervision.
3. That the data was obtained on representative units, randomly selected.
4. That, the facts set forth in the application and accompanying technical data is true and correct to the best of my knowledge and belief.

A handwritten signature in black ink that reads "Greg Corbin".

Certifying Engineer:

Greg Corbin



## Table of Contents

<b><u>Rule</u></b>	<b><u>Description</u></b>	<b><u>Page</u></b>
2.1033(c)(14)	Rule Summary	3
	Standard Test Conditions and Engineering Practices	4
2.1033(c)	General Information Required	6
	Test Results Summary	8
2.1046	Carrier Output Power (Conducted)	9
2.1051	Conducted Spurious Emissions	10
2.1053	Field Strength of Spurious Radiation	18
90.210	Emission Masks (Occupied Bandwidth)	23
90.214	Transient Frequency Behavior	43
2.1047	Audio Low Pass Filter (Voice Input)	46
2.1047	Audio Frequency Response	47
2.1047	Modulation Limiting	48
90.213	Frequency Stability (Temperature Variation)	51
90.213	Frequency Stability (Voltage Variation)	52
RSS-GEN	Receiver Spurious Emissions	53
2.202	Necessary Bandwidth Calculations)	55
	Test Equipment Utilized	56



Sub-part

2.1033(c)(14):

## **Test and Measurement Data**

All tests and measurement data shown were performed in accordance with FCC Rules and Regulations, Volume II; Part 2, Sub-part J, Sections 2.947, 2.1033(c), 2.1041, 2.1046, 2.1047, 2.1079, 2.1051, 2.1053, 2.1055, 2.1057 and the following individual Parts: 90.

## Standard Test Conditions and Engineering Practices

Except as noted herein, the following conditions and procedures were observed during the testing:

In accordance with ANSI/C63.4-2009, and unless otherwise indicated in the specific measurement results, the ambient temperature of the actual EUT was maintained within the range of 10° to 40°C (50° to 104 °F) unless the particular equipment requirements specify testing over a different temperature range. Also, unless otherwise indicated, the humidity levels were in the range of 10% to 90% relative humidity.

Environmental Conditions		
Temperature	Humidity	Pressure
22.5 deg C	43.1 %	976.1 mbar

Measurement results, unless otherwise noted, are worst-case measurements.





**Compliance Testing, LLC**  
Previously Flom Test Lab

## A2LA

“A2LA has accredited Compliance Testing, LLC, in Chandler, AZ for technical competence in the field of Electrical testing. The accreditation covers the specific tests and types of tests listed on the agreed scope of accreditation. This laboratory meets the requirements of ISO 17025:2005 ‘General Requirements for the Competence of Testing and Calibration Laboratories’ and any additional program requirements in the identified field of testing.”

Please refer to [www.a2la.org](http://www.a2la.org) for current scope of accreditation.

Certificate number: 2152.01



**TESTING CERT# 2152.01**

**FCC OATS Reg. #933597**

**IC Reg. # 2044A-1**



### List of General Information Required for Certification

In Accordance with FCC Rules and Regulations,  
Volume II, Part 2 and to Part 90

Sub-part 2.1033

(c)(1):

**Name and Address of Applicant:** Kenwood USA Corporation  
Communications Division  
3970 Johns Creek Court, Suite 100  
Suwanee, GA 30024

**Manufacturer:** Kenwood Corporation  
2967-3, Ishikawa-machi  
Hachioji-shi, Tokyo 192-8525  
Japan

(c)(2): **FCC ID:** ALH430900

**Model Number:** NX-220-K, NX-220-K2, NX-220-K3

(c)(3): **Instruction Manual(s):**  
  
Please see attached exhibits

(c)(4): **Type of Emission:** FM

(c)(5): **Frequency Range, MHz:** FCC: 150 – 174 MHz  
IC: 138 – 144 MHz and 148 – 174 MHz

(c)(6): **Power Rating, Watts:** 5 (continuously variable to 1 watt)  
  
 Switchable       Variable       N/A

**FCC Grant Note:**

(c)(7): **Maximum Allowable Power, Watts:** 5

DUT Results: Passes  Fails

Subpart 2.1033 (continued)

(c)(8): **Voltages & currents in all elements in final RF stage, including final transistor or solid-state device:**

Collector Current, A	=	2.3
Collector Voltage, Vdc	=	7.5
Supply Voltage, Vdc	=	7.5

(c)(9): **Tune-Up Procedure:**

Please see attached exhibits

(c)(10): **Circuit Diagram/Circuit Description:**

Including description of circuitry & devices provided for determining and stabilizing frequency, for suppression of spurious radiation, for limiting modulation and limiting power.

Please see attached exhibits

(c)(11): **Label Information:**

Please see attached exhibits

(c)(12): **Photographs:**

Please see attached exhibits

(c)(13): **Digital Modulation Description:**

Attached Exhibits  
 N/A

(c)(14): **Test and Measurement Data:**

Follows



### Test Results Summary

Specification	Test Name	Pass, Fail, N/A	Comments
2.1046	Carrier Output Power (Conducted)	Pass	
2.1051	Unwanted Emissions (Transmitter Conducted)	Pass	
2.1053	Field Strength of Spurious Radiation	Pass	
90.210	Emission Masks (Occupied Bandwidth)	Pass	
2.1047	Audio Low Pass Filter (Voice Input)	Pass	
2.1047	Audio Frequency Response	Pass	
2.1047	Modulation Limiting	Pass	
90.213	Frequency Stability (Temperature Variation)	Pass	
90.213	Frequency Stability (Voltage Variation)	Pass	
RSS-GEN	Receiver Spurious Emissions	Pass	

**Accessories used during testing:**

<u>Type</u>	<u>Quantity</u>	<u>Manufacturer</u>	<u>Model</u>	<u>Serial No.</u>	<u>FCC ID</u>
Audio Test Jig	1	Kenwood	N/A	0050	N/A
Rapid Charger	1	Kenwood	KSC 25	0272	N/A
AC Adapter	1	Kenwood	W08 1058	0273	N/A
Microphone	1	Kenwood	KMC 45	0062	N/A
Antenna	1	Kenwood	KRA-22 M	0205	N/A
Antenna	1	Kenwood	KRA-22 M2	0240	N/A
Antenna	1	Kenwood	KRA-22 M3	0371	N/A
Antenna	1	Kenwood	KRA-25	0361	N/A
Antenna	1	Kenwood	KRA-26 M	0124	N/A
Antenna	1	Kenwood	KRA-26 M2	0193	N/A
Antenna	1	Kenwood	KRA-26 M3	0373	N/A
Antenna	1	Kenwood	KRA-28 M	0363	N/A

**Name of Test:** Carrier Output Power (Conducted)  
**Specification:** 2.1046  
**Test Equipment Utilized:** i00228, i00344

**Engineer:** G. Corbin  
**Test Date:** 12/20/2010

### Measurement Procedure

The Equipment Under Test (EUT) was connected directly to a power meter input. The peak readings were taken and the result was then compared to the limit.

### Test Setup

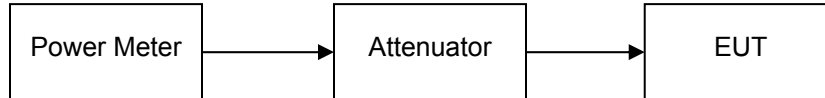

### High Power Transmitter Peak Output Power

Tuned Frequency MHz	Recorded Measurement dBm	Result
138.05 (IC only)	37.00	Pass
141.05 (IC only)	37.03	Pass
143.95 (IC only)	37.00	Pass
148.05 (IC only)	36.94	Pass
150.05 (FCC/IC)	36.95	Pass
162.05 (FCC/IC)	37.02	Pass
173.95 (FCC/IC)	36.99	Pass

**Name of Test:** Conducted Spurious Emissions  
**Specification:** 2.1051  
**Test Equipment Utilized:** i00126, i00331

**Engineer:** G. Corbin  
**Test Date:** 12/21/2010

### Test Procedure

The EUT was connected directly to a spectrum analyzer to verify that the UUT met the requirements for spurious emissions. A tunable notch filter was utilized to ensure the fundamental did not put the spectrum analyzer into compression. The resolution bandwidth set for 100 kHz and the reference level was adjusted to ensure the system had sufficient dynamic range to measure spurious emissions. The frequency range from 30 MHz to the 10<sup>th</sup> harmonic of the fundamental transmitter was observed and plotted.

### Test Setup

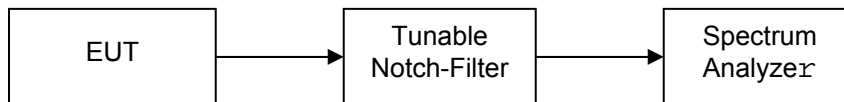

**High Power Conducted Spurious Emissions Summary Test Table**

Tuned Frequency (MHz)	Spurious Frequency (MHz)	Measured Spurious Level (dBm)	Specification Limit (dBm)	Result
138.05 (RSS-119 only)	1707.5	-30.6	-25	Pass
141.05 (RSS-119 only)	1940.0	-30.3	-25	Pass
143.95 (RSS-119 only)	1822.5	-29.8	-25	Pass
148.05 (RSS-119 only)	1910.0	-29.2	-25	Pass
150.05	1627.5	-29.7	-25	Pass
162.05	1862.5	-29.7	-25	Pass
173.95	1980.0	-30.4	-25	Pass



### Conducted Emissions Test Plots

138.05 MHz (RSS-119 only)

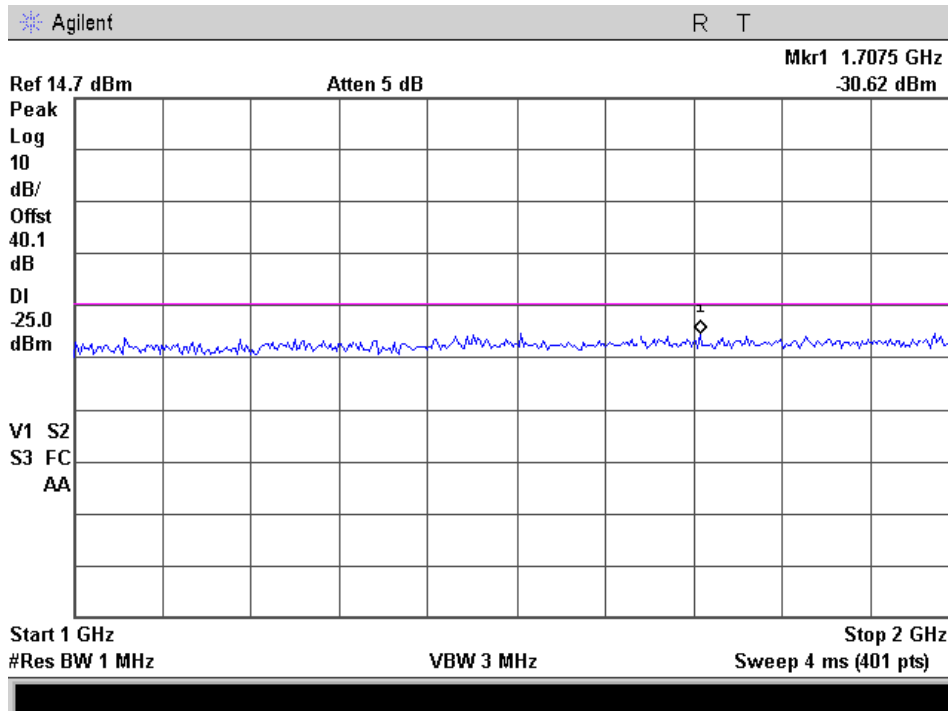
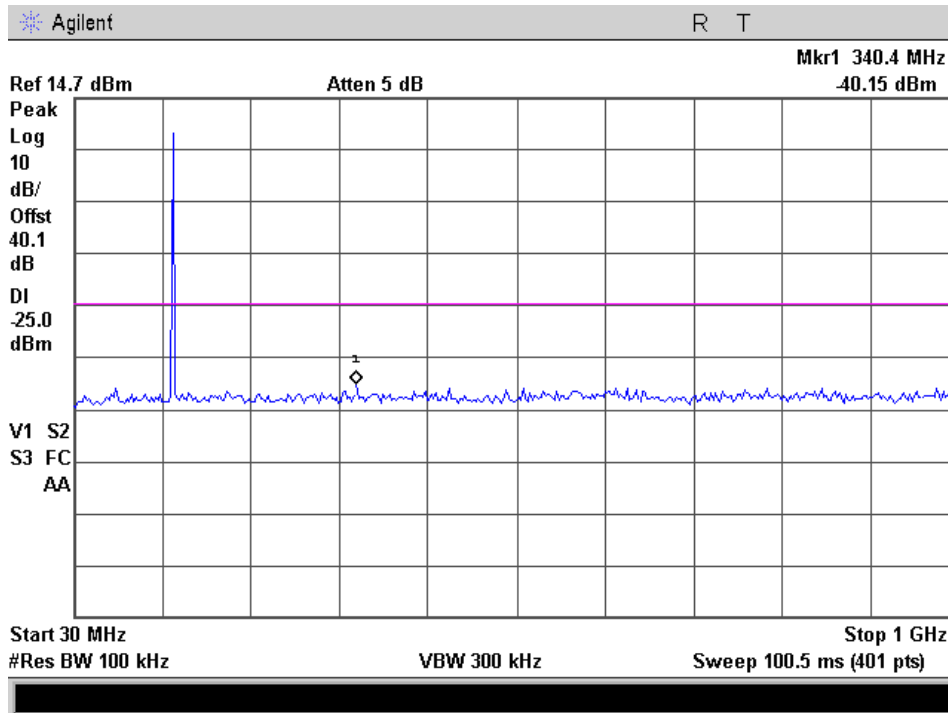



### 141.05 MHz (RSS-119 only)

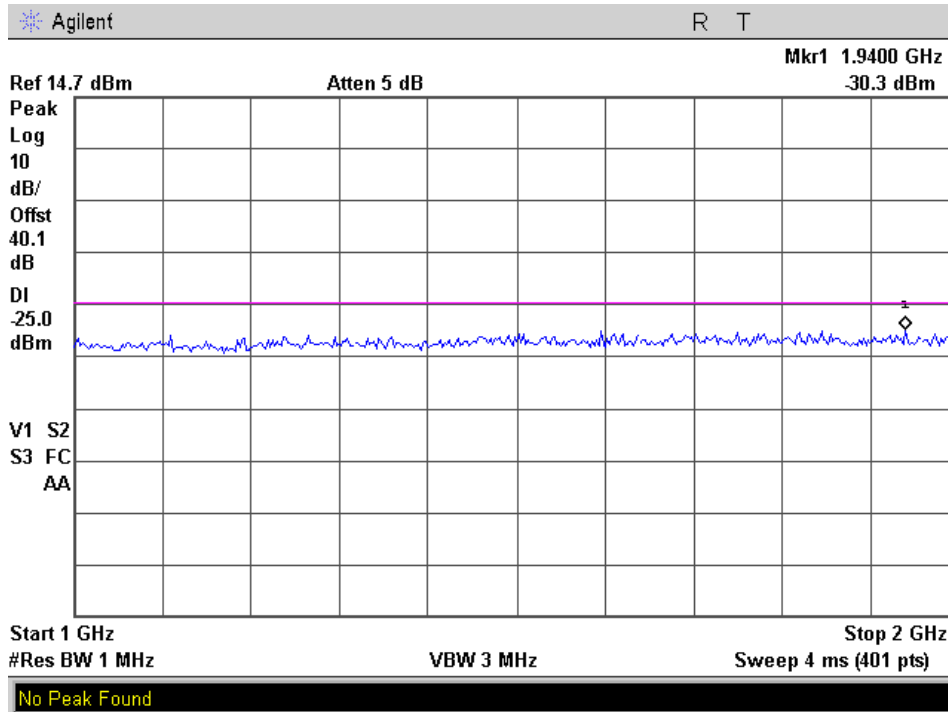
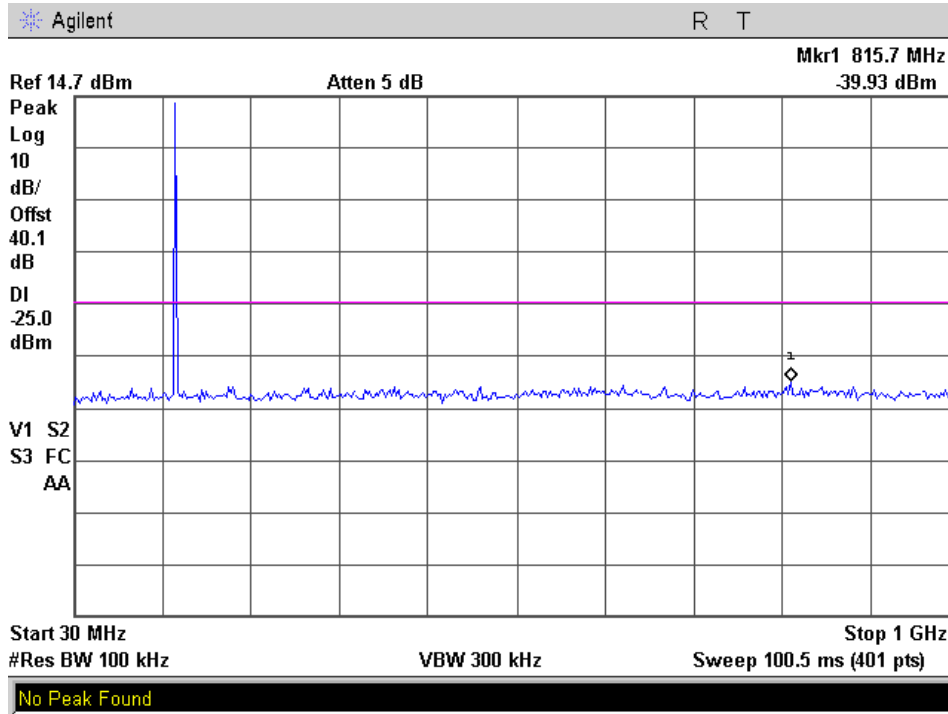





### 143.95 MHz (RSS-119 only)

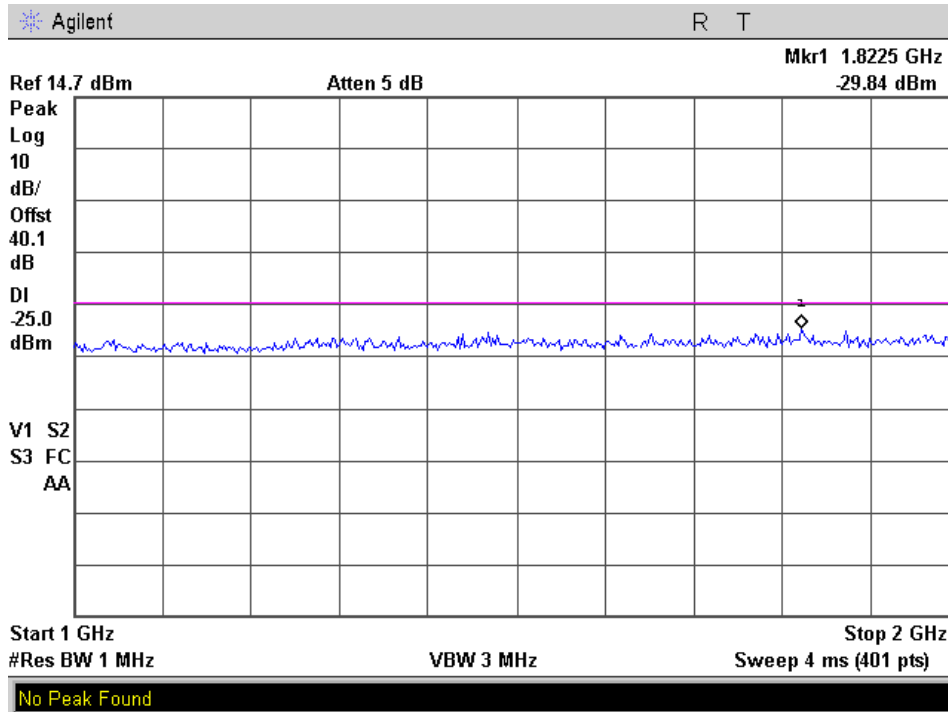
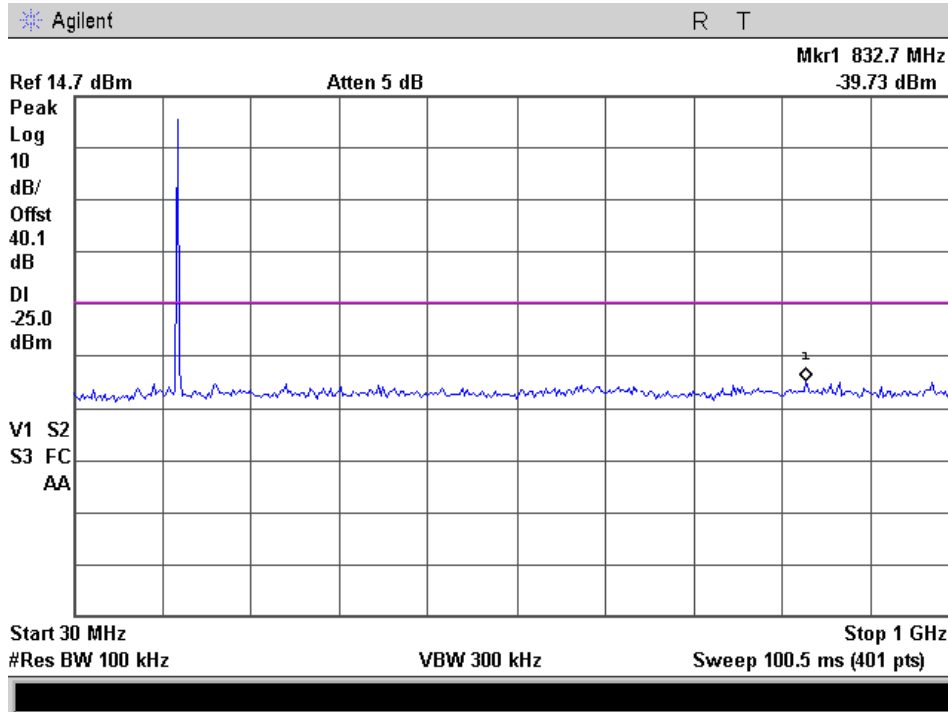



### 148.05 MHz (RSS-119 only)

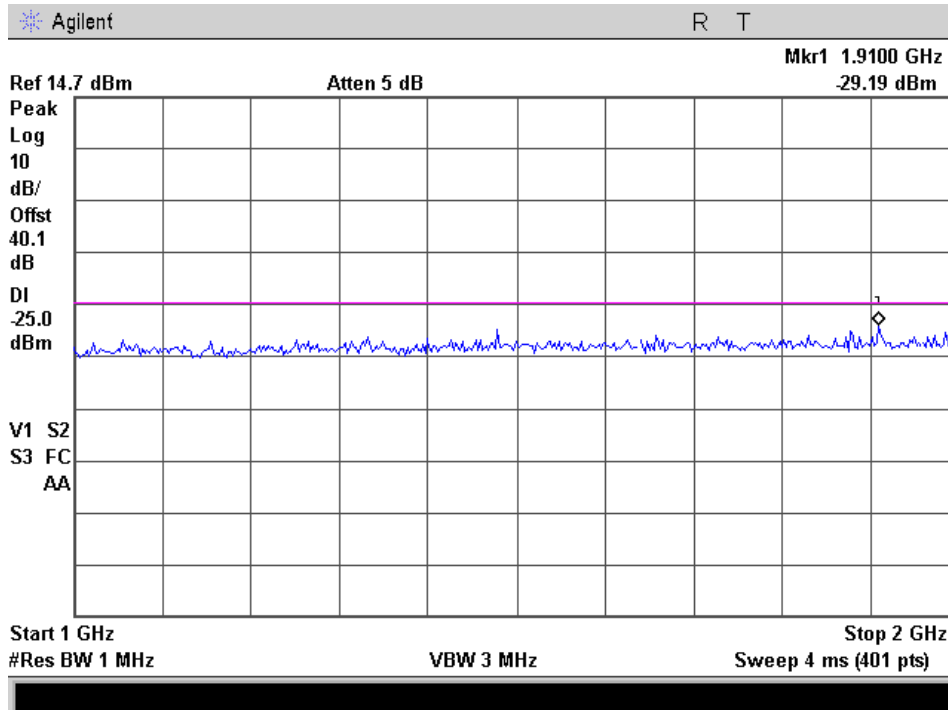
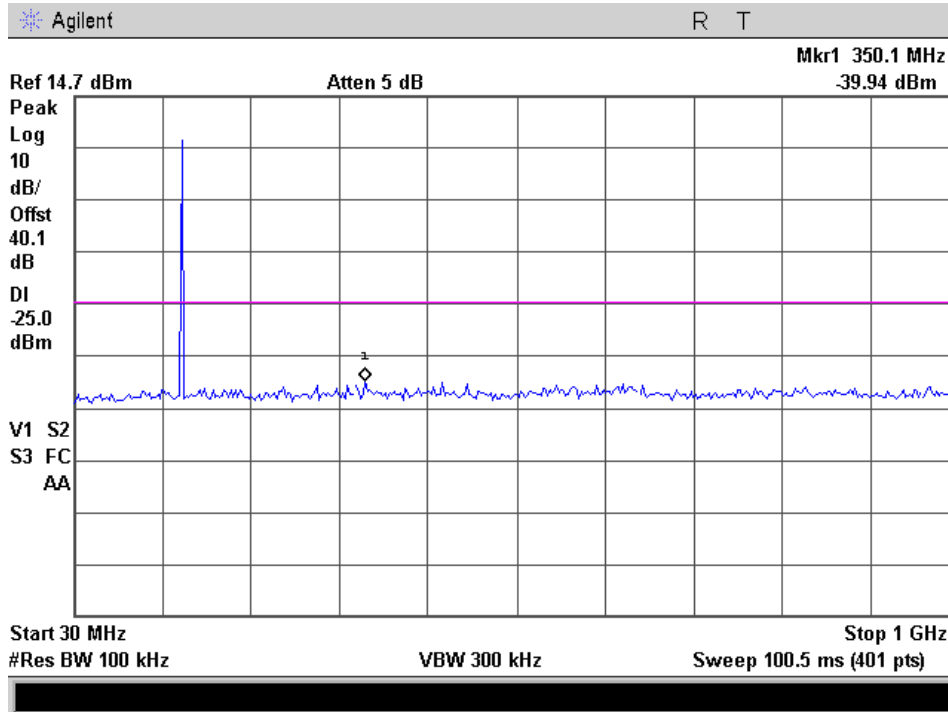



### 150.05 MHz

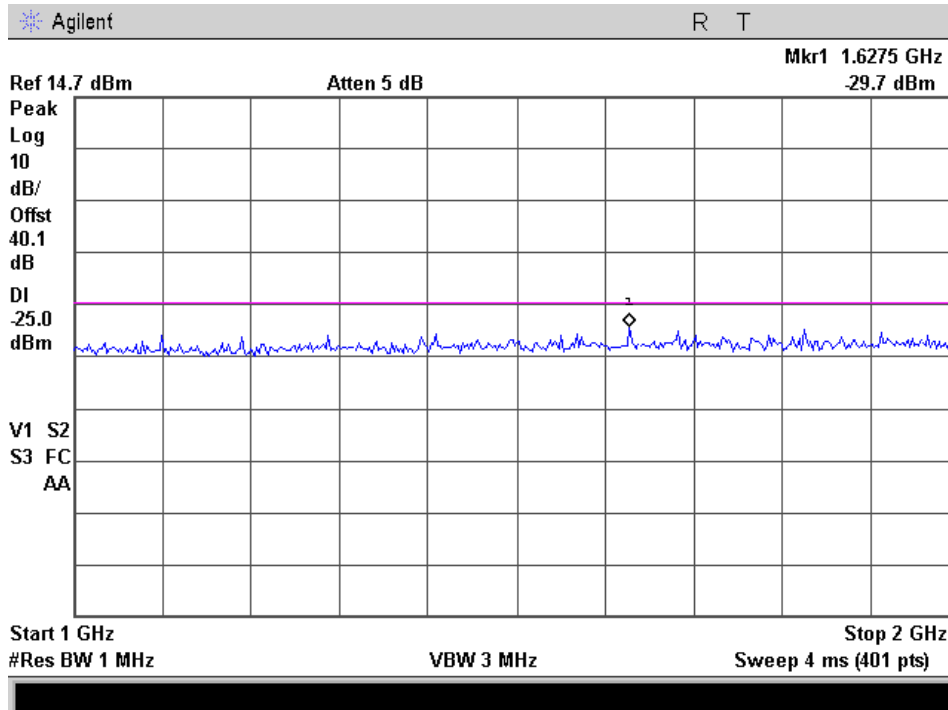
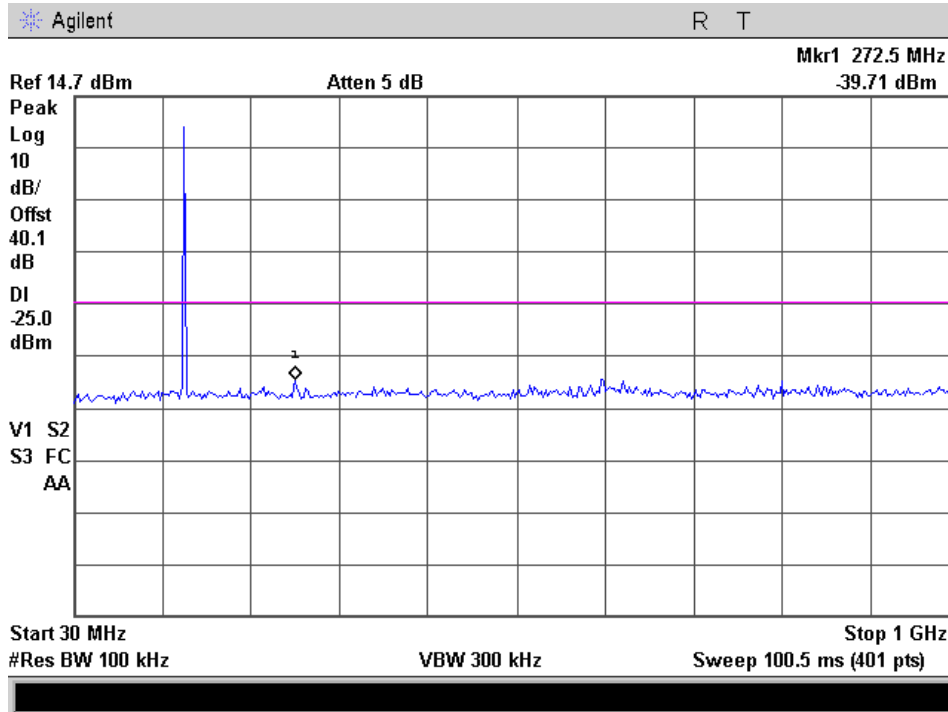



### 162.05 MHz

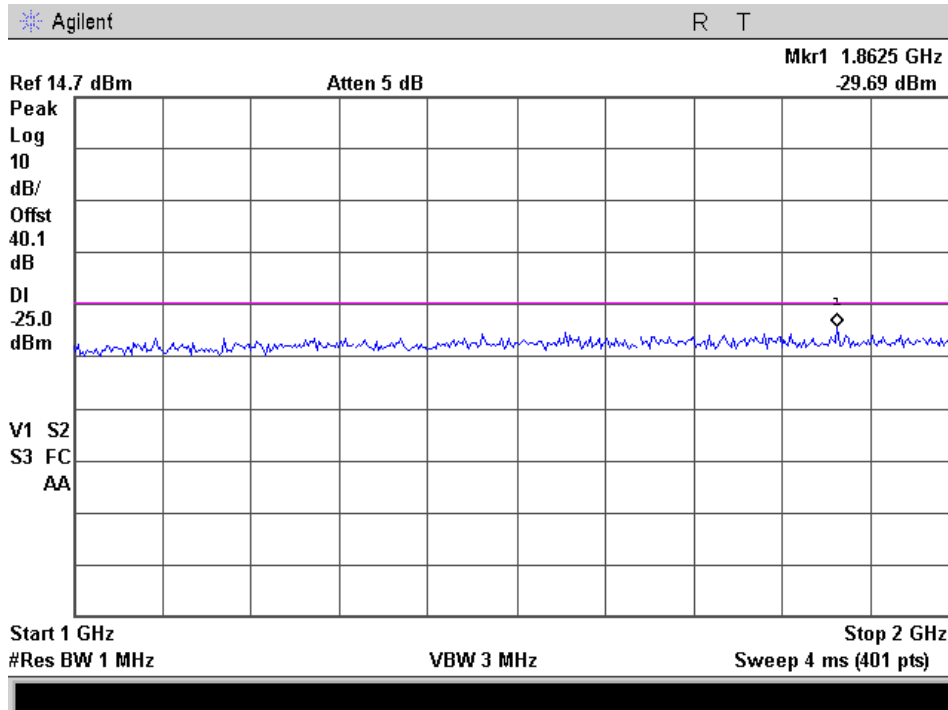
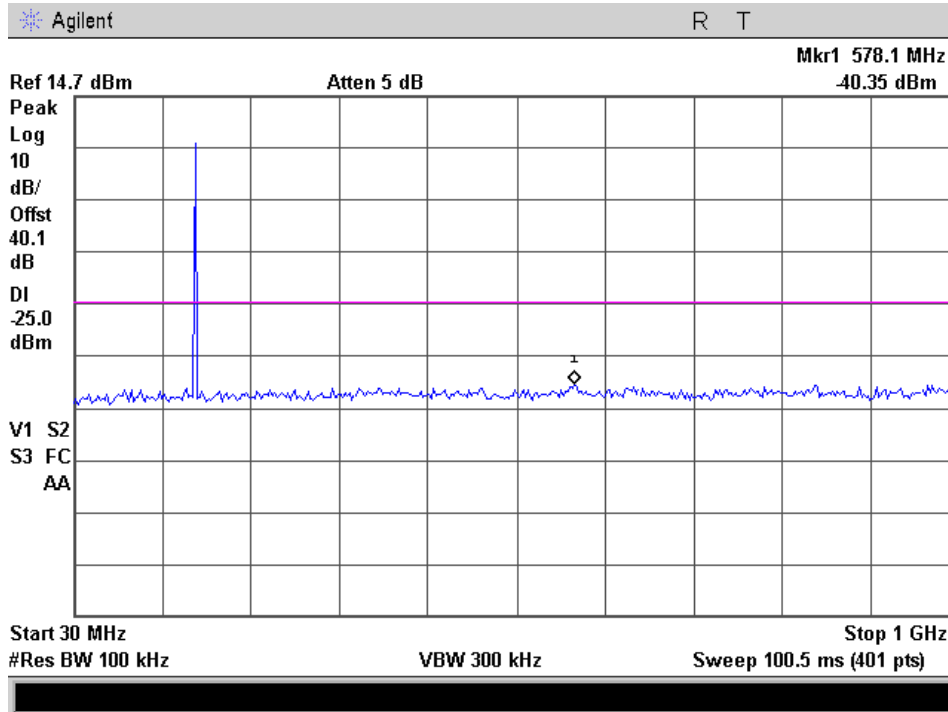



### 173.95 MHz

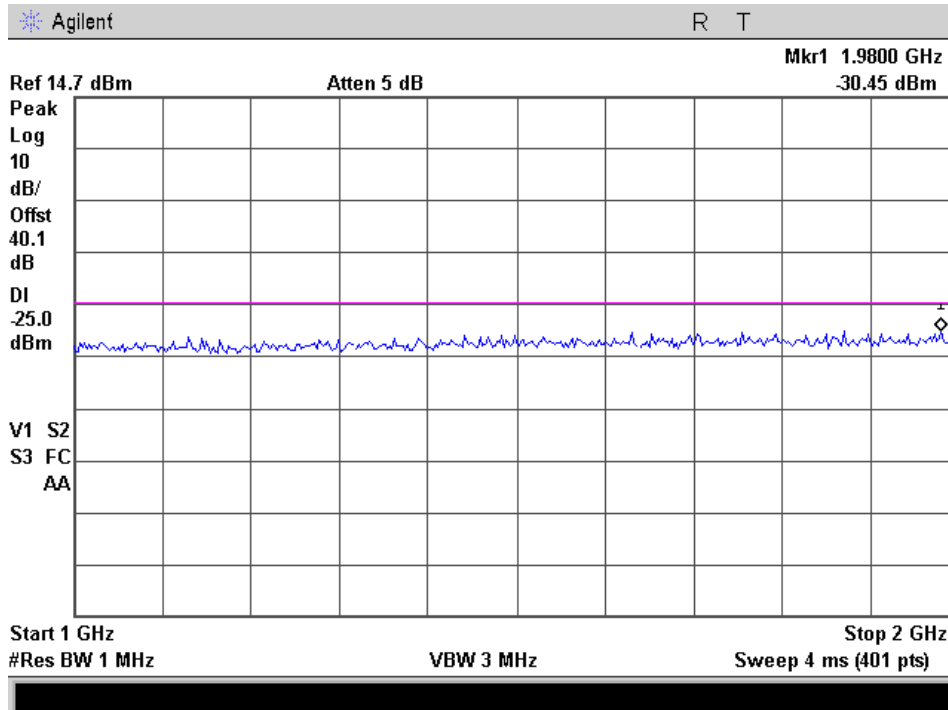
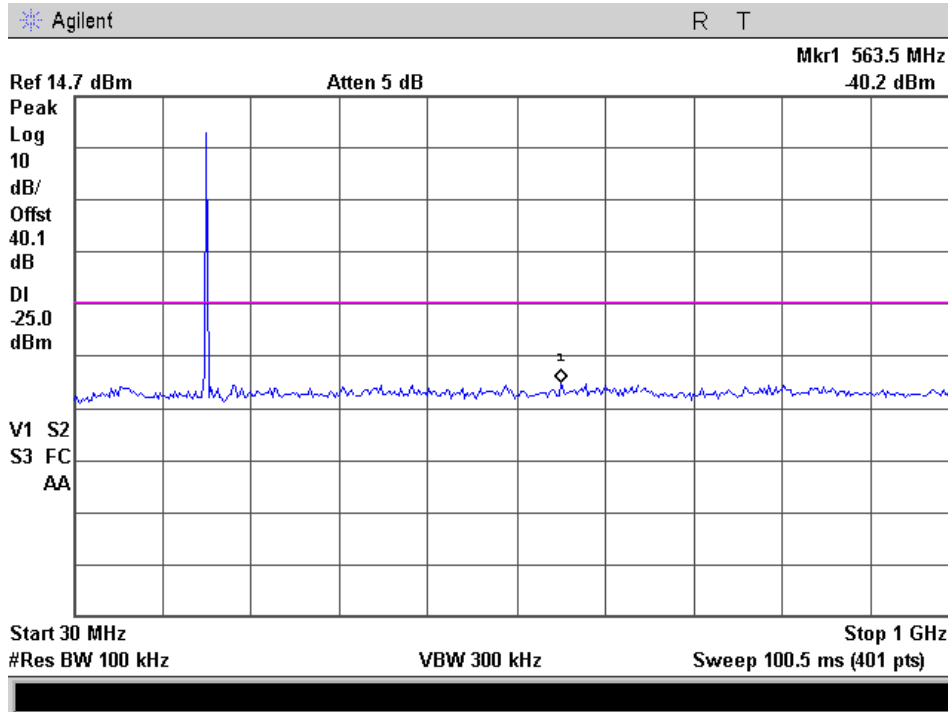



**Name of Test:** Field Strength of Spurious Radiation  
**Specification:** 2.1053  
**Test Equipment Utilized:** i00003, i00033, i00039, i00042, i00048, i00126, i00266, i00267  
**Engineer:** G. Corbin  
**Test Date:** 12/27/2010

### Test Procedure

- A) Connect the equipment as illustrated
- B) Adjust the spectrum analyzer for the following settings:
  - 1) Resolution Bandwidth 100 kHz (<1 GHz), 1 MHz (> 1GHz).
  - 2) Video Bandwidth  $\geq 3$  times Resolution Bandwidth, or 30 kHz
  - 3) Sweep Speed  $\leq 2000$  Hz/second
  - 4) Detector Mode = Mean or Average Power
- C) Place the transmitter to be tested on the turntable in the standard test site. The transmitter is transmitting into a non-radiating load that is placed on the turntable. The RF cable to this load should be of minimum length.
- D) For each spurious measurement the test antenna should be adjusted to the correct length for the frequency involved. This length may be determined from a calibration ruler supplied with the equipment. Measurements shall be made from the lowest radio frequency generated in the equipment to the tenth harmonic of the carrier, except for the region close to the carrier equal to  $\pm$  the test bandwidth (see section 1.3.4.4).
- E) For each spurious frequency, raise and lower the test antenna from 1 m to 4 m to obtain a maximum reading on the spectrum analyzer with the test antenna at horizontal polarity. Repeat this procedure to obtain the highest possible reading. Record this maximum reading.
- F) Repeat step E) for each spurious frequency with the test antenna polarized vertically.
- G) Reconnect the equipment as illustrated.
- H) Keep the spectrum analyzer adjusted as in step B).
- I) Remove the transmitter and replace it with a substitution antenna (the antenna should be half-wavelength for each frequency involved). The center of the substitution antenna should be approximately at the same location as the center of the transmitter. At lower frequencies, where the substitution antenna is very long, this will be impossible to achieve when the antenna is polarized vertically. In such case the lower end of the antenna should be 0.3 m above the ground.
- J) Feed the substitution antenna at the transmitter end with a signal generator connected to the antenna by means of a non-radiating cable. With the antennas at both ends horizontally polarized and with the signal generator tuned to a particular spurious frequency, raise and lower the test antenna to obtain a maximum reading at the spectrum analyzer. Adjust the level of the signal generator output until the previously recorded maximum reading for this set of conditions is obtained. This should be done carefully repeating the adjustment of the test antenna and generator output.
- K) Repeat step J) with both antennas vertically polarized for each spurious frequency.
- L) Calculate power in dBm into a reference ideal half-wave dipole antenna by reducing the readings obtained in steps J) and K) by the power loss in the cable between the generator and the antenna and further corrected for the gain of the substitution antenna used relative to an ideal half-wave dipole antenna.
- M) The levels recorded in step L) are absolute levels of radiated spurious emissions in dBm. The radiated spurious emissions in dB can be calculated by the following:

Radiated spurious emissions dB =  $10\log_{10}(\text{TX power in watts}/0.001)$  – the levels in step I)

*NOTE: It is permissible that other antennas provided can be referenced to a dipole.*

### Test Setup

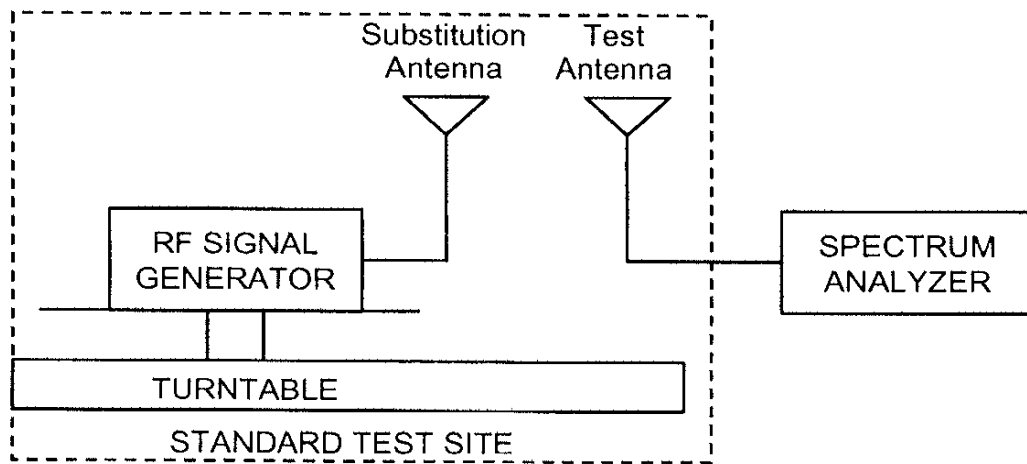
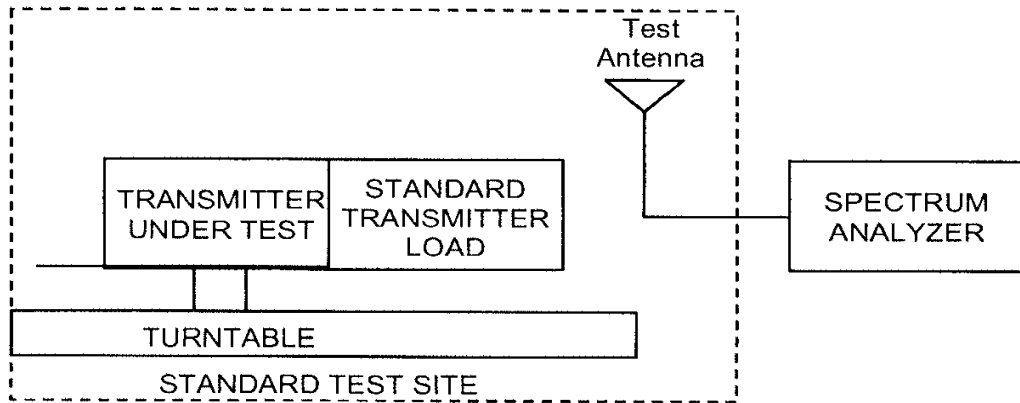



**Radiated Spurious Emissions 22M Test Results**

Tuned Frequency (MHz)	Emission Frequency (MHz)	Measured Level (dBm)	Correction Factor (dB)	Corrected Value (dBm)	Limit (dBm)	Margin (dB)
148.05 (RSS-119 only)	296.1	-69.3	15.8	-53.5	-25	-28.5
148.05 (RSS-119 only)	444.15	-50.8	19.5	-31.3	-25	-6.3
148.05 (RSS-119 only)	592.2	-61.8	21.9	-39.9	-25	-14.9
148.05 (RSS-119 only)	740.25	-70.6	23.5	-47.1	-25	-22.1
162.05	324.1	-75.8	16.1	-59.7	-25	-34.7
162.05	486.15	-46.8	20.3	-26.5	-25	-1.5
162.05	648.2	-70.1	23.1	-47	-25	-22
162.05	810.25	-70.2	24.5	-45.7	-25	-20.7

**Radiated Spurious Emissions 22M2 Test Results**

Tuned Frequency (MHz)	Emission Frequency (MHz)	Measured Level (dBm)	Correction Factor (dB)	Corrected Value (dBm)	Limit (dBm)	Margin (dB)
162.05	324.1	-73.6	16.1	-57.5	-25	-32.5
162.05	486.15	-52.3	20.3	-32	-25	-7
162.05	648.2	-75.8	23.1	-52.7	-25	-27.7
162.05	810.25	-72.9	24.5	-48.4	-25	-23.4
173.95	347.9	-69.4	16.9	-52.5	-25	-27.5
173.95	521.85	-64.6	20.7	-43.9	-25	-18.9
173.95	695.8	-62.2	23	-39.2	-25	-14.2
173.95	869.75	-71	25.2	-45.8	-25	-20.8

**Radiated Spurious Emissions 22M3 Test Results**

Tuned Frequency (MHz)	Emission Frequency (MHz)	Measured Level (dBm)	Correction Factor (dB)	Corrected Value (dBm)	Limit (dBm)	Margin (dB)
138.05	276.1	-78.7	15.4	-63.3	-25	-38.3
138.05	414.15	-65.7	19.4	-46.3	-25	-21.3
138.05	552.2	-79	21.9	-57.1	-25	-32.1
138.05	690.25	-78.4	23	-55.4	-25	-30.4
141.05	282.1	-78.2	15.5	-62.7	-25.0	-37.7
141.05	423.15	-63.7	19.4	-44.3	-25.0	-19.3
141.05	564.2	-79.5	21.9	-57.6	-25.0	-32.6
141.05	705.25	-75.0	23.2	-51.8	-25.0	-26.8
143.95	287.9	-79.1	15.6	-63.5	-25	-38.5
143.95	431.85	-64.7	19.5	-45.2	-25	-20.2
143.95	575.8	-78.2	21.9	-56.3	-25	-31.3
143.95	719.75	-74	23.4	-50.6	-25	-25.6
150.05	300.1	-77.1	15.9	-61.2	-25	-36.2
150.05	450.15	-54.1	19.5	-34.6	-25	-9.6
150.05	600.2	-78.8	21.8	-57	-25	-32.0
150.05	750.25	-77	23.8	-53.2	-25	-28.2





**Radiated Spurious Emissions 25 Test Results**

Tuned Frequency (MHz)	Emission Frequency (MHz)	Measured Level (dBm)	Correction Factor (dB)	Corrected Value (dBm)	Limit (dBm)	Margin (dB)
148.05 (RSS-119 only)	296.1	-72.1	15.8	-56.3	-25	-31.3
148.05 (RSS-119 only)	444.15	-73.4	19.5	-53.9	-25	-28.9
148.05 (RSS-119 only)	592.2	-74.1	21.9	-52.2	-25	-27.2
148.05 (RSS-119 only)	740.25	-71.6	23.5	-48.1	-25	-23.1
162.05	324.1	-72.7	16.1	-56.6	-25	-31.6
162.05	486.15	-66.7	20.3	-46.4	-25	-21.4
162.05	648.2	-73.2	23.1	-50.1	-25	-25.1
162.05	810.25	-68.7	24.5	-44.2	-25	-19.2

**Radiated Spurious Emissions 26M Test Results**

Tuned Frequency (MHz)	Emission Frequency (MHz)	Measured Level (dBm)	Correction Factor (dB)	Corrected Value (dBm)	Limit (dBm)	Margin (dB)
148.05 (RSS-119 only)	296.1	-75.9	15.8	-60.1	-25	-35.1
148.05 (RSS-119 only)	444.15	-73.8	19.5	-54.3	-25	-29.3
148.05 (RSS-119 only)	592.2	-73.9	21.9	-52	-25	-27
148.05 (RSS-119 only)	740.25	-73.7	23.5	-50.2	-25	-25.2
162.05	324.1	-74.5	16.1	-58.4	-25	-33.4
162.05	486.15	-63.1	20.3	-42.8	-25	-17.8
162.05	648.2	-71.5	23.1	-48.4	-25	-23.4
162.05	810.25	-69.9	24.5	-45.4	-25	-20.4

**Radiated Spurious Emissions 26M2 Test Results**

Tuned Frequency (MHz)	Emission Frequency (MHz)	Measured Level (dBm)	Correction Factor (dB)	Corrected Value (dBm)	Limit (dBm)	Margin (dB)
162.05	324.1	-76.3	16.1	-60.2	-25	-35.2
162.05	486.15	-62.6	20.3	-42.3	-25	-17.3
162.05	648.2	-69.9	23.1	-46.8	-25	-21.8
162.05	810.25	-73.6	24.5	-49.1	-25	-24.1
173.95	347.9	-73.1	16.9	-56.2	-25	-31.2
173.95	521.85	-73.7	20.7	-53	-25	-28
173.95	695.8	-58.2	23	-35.2	-25	-10.2
173.95	869.75	-75.9	25.2	-50.7	-25	-25.7



**Radiated Spurious Emissions 26M3 Test Results**

Tuned Frequency (MHz)	Emission Frequency (MHz)	Measured Level (dBm)	Correction Factor (dB)	Corrected Value (dBm)	Limit (dBm)	Margin (dB)
138.05	276.1	-78.8	15.4	-63.4	-25	-38.4
138.05	414.15	-78.5	19.4	-59.1	-25	-34.1
138.05	552.2	-78.7	21.9	-56.8	-25	-31.8
138.05	690.25	-79.4	23	-56.4	-25	-31.4
141.05	282.1	-79.3	15.5	-63.8	-25	-38.8
141.05	423.15	-80.2	19.4	-60.8	-25	-35.8
141.05	564.2	-78.8	21.9	-56.9	-25	-31.9
141.05	705.25	-79.2	23.2	-56	-25	-31.0
143.95	287.9	-80.7	15.6	-65.1	-25.0	-40.1
143.95	431.85	-80.0	19.5	-60.5	-25.0	-35.5
143.95	575.8	-78.9	21.9	-57.0	-25.0	-32.0
143.95	719.75	-74.7	23.4	-51.3	-25.0	-26.3
150.05	300.1	-80.5	15.9	-64.6	-25	-39.6
150.05	450.15	-78.9	19.5	-59.4	-25	-34.4
150.05	600.2	-79.1	21.8	-57.3	-25	-32.3
150.05	750.25	-78.8	23.8	-55	-25	-30.0

**Radiated Spurious Emissions 28M Test Results**

Tuned Frequency (MHz)	Emission Frequency (MHz)	Measured Level (dBm)	Correction Factor (dB)	Corrected Value (dBm)	Limit (dBm)	Margin (dB)
138.05 (RSS-119 only)	276.1	-66	15.4	-50.6	-25	-25.6
128.05 (RSS-119 only)	414.15	-70.4	19.4	-51	-25	-26
138.05 (RSS-119 only)	552.2	-73	21.9	-51.1	-25	-26.1
138.05 (RSS-119 only)	690.25	-74.6	23	-51.6	-25	-26.6
150.05	300.1	-73.8	15.9	-57.9	-25	-32.9
150.05	450.15	-71.9	19.5	-52.4	-25	-27.4
150.05	600.2	-71.1	21.8	-49.3	-25	-24.3
150.05	750.25	-72	23.8	-48.2	-25	-23.2
173.95	347.9	-73.1	16.9	-56.2	-25	-31.2
173.95	521.85	-72.1	20.7	-51.4	-25	-26.4
173.95	695.8	-61.7	23	-38.7	-25	-13.7
173.95	869.75	-72.7	25.2	-47.5	-25	-22.5

No other emissions were detected. All emissions were greater than -25 dBm.

**Name of Test:** Emission Masks (Occupied Bandwidth)  
**Specification:** 90.210  
**Test Equipment Utilized:** i00118, i00331

**Engineer:** G. Corbin  
**Test Date:** 12/21/2010

The EUT was connected directly to a spectrum analyzer to verify that the EUT meets the required emissions mask. A reference level plot is provided to verify that the peak power was established prior to testing the mask. A modulation frequency of 2.5 kHz at a level of 500 mVPP was input into the EUT for the analog tests and an internal test pattern was utilized for the digital input.

**Test Setup**

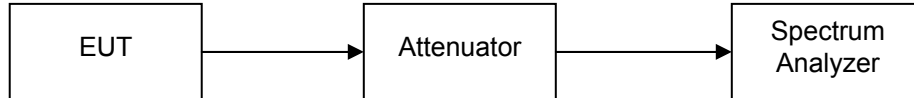

**Occupied Bandwidth Plots**

**Reference Plots**

**138.05 MHz (RSS-119 only)**

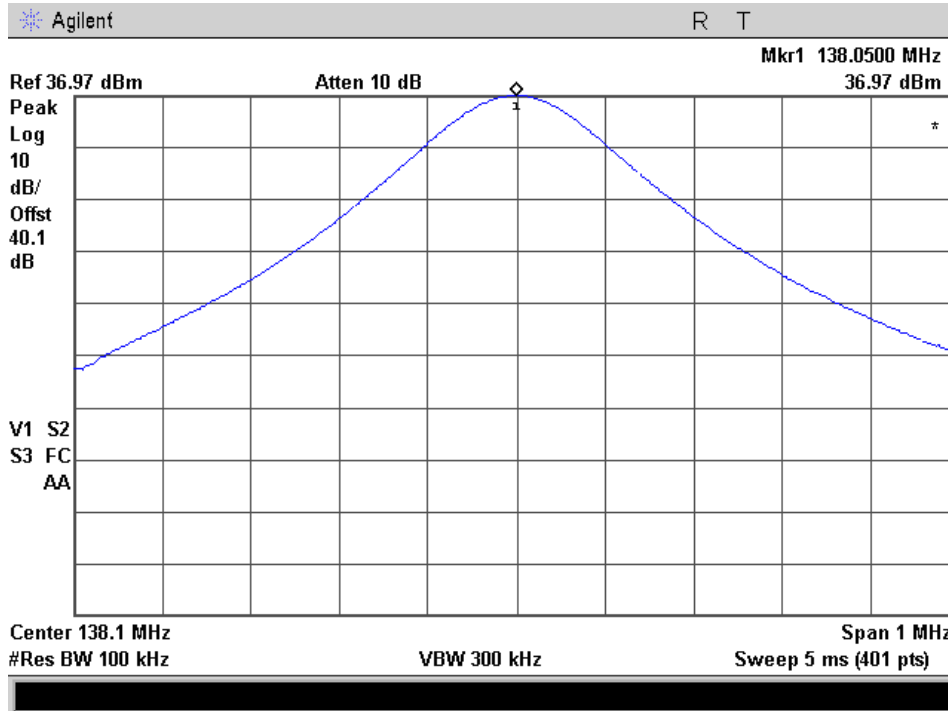



### 141.05 MHz (RSS-119 only)

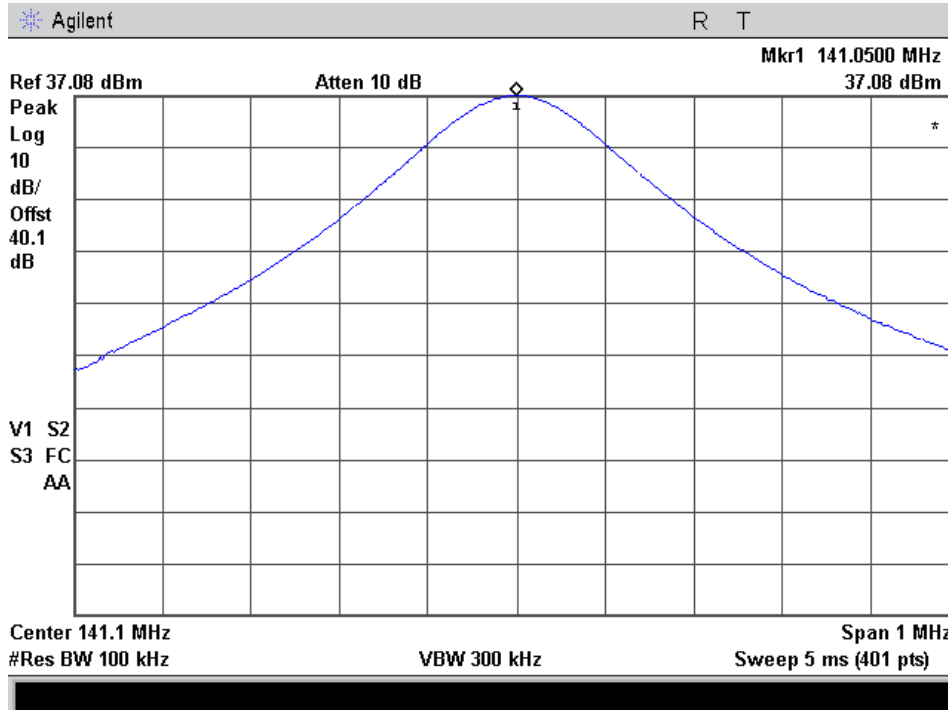

### 143.95 MHz (RSS-119 only)

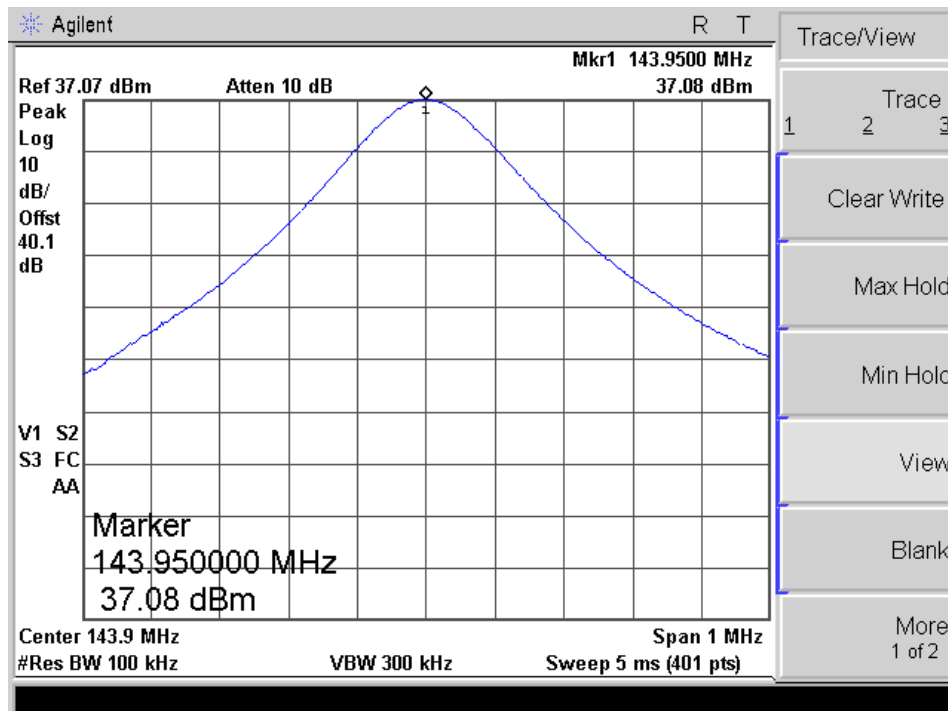



### 148.05 MHz (RSS-119 only)

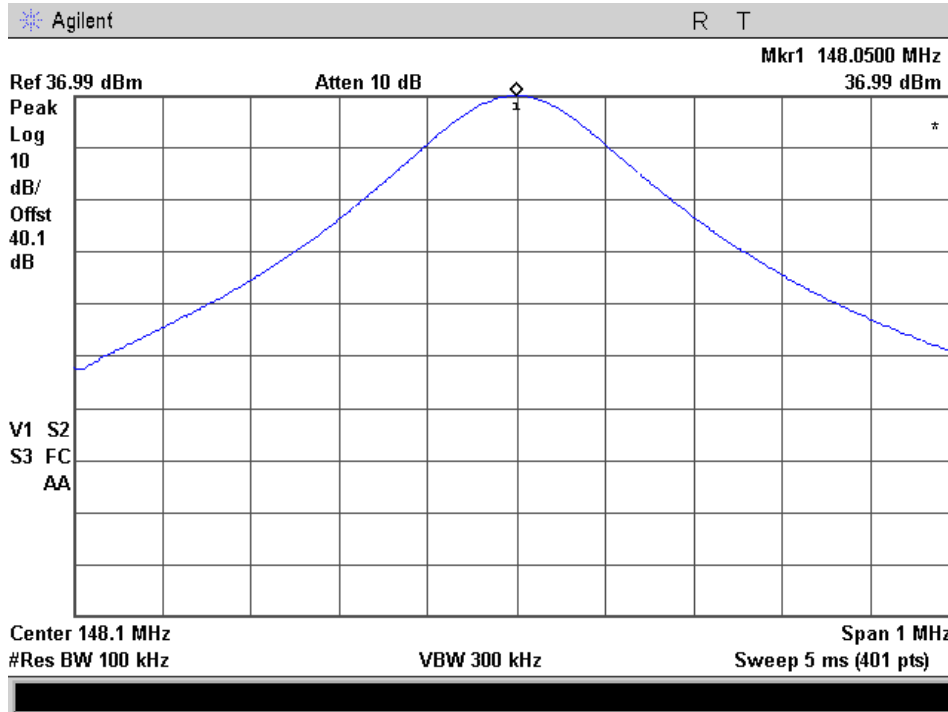

### 150.05 MHz

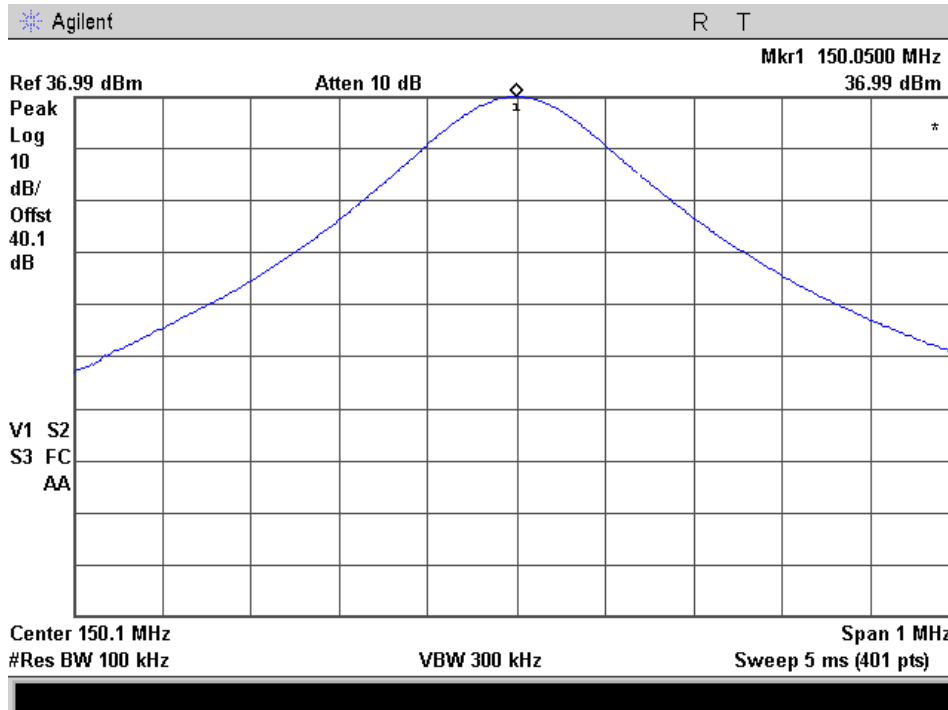



### 162.05 MHz

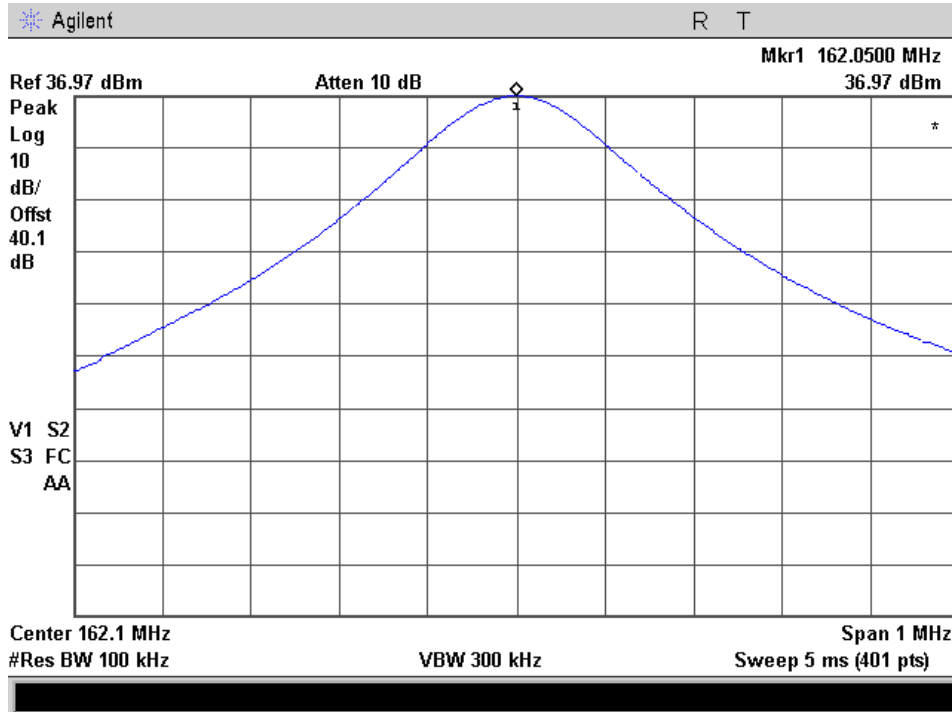

### 173.95 MHz

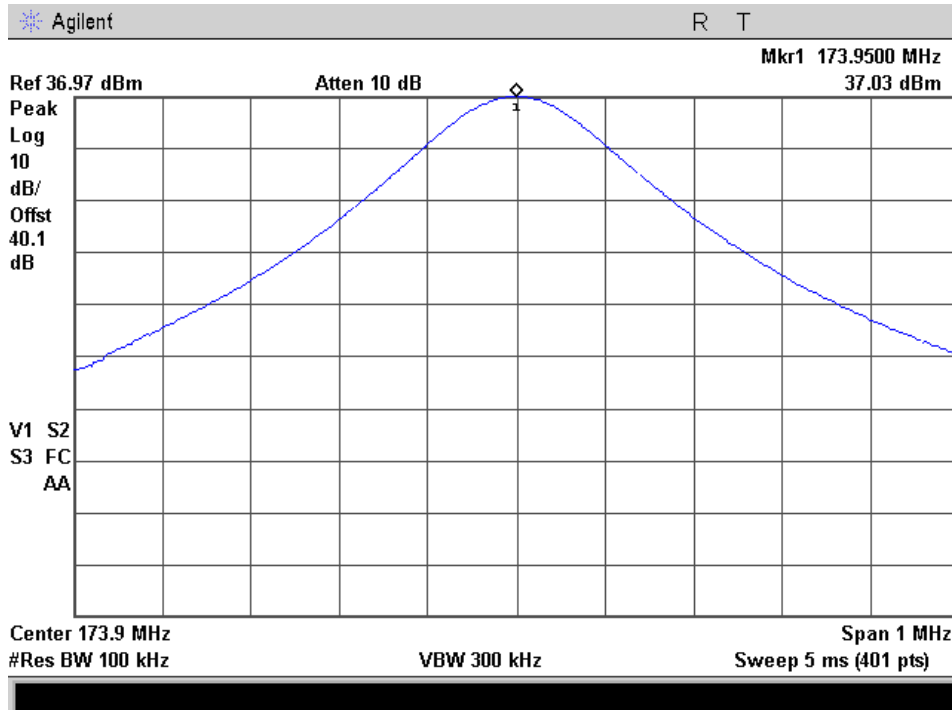



Wideband, Mask B, (IC only)  
Ch. BW = 25 KHz, Emission BW = 16K0

138.05 MHz (RSS-119 only)

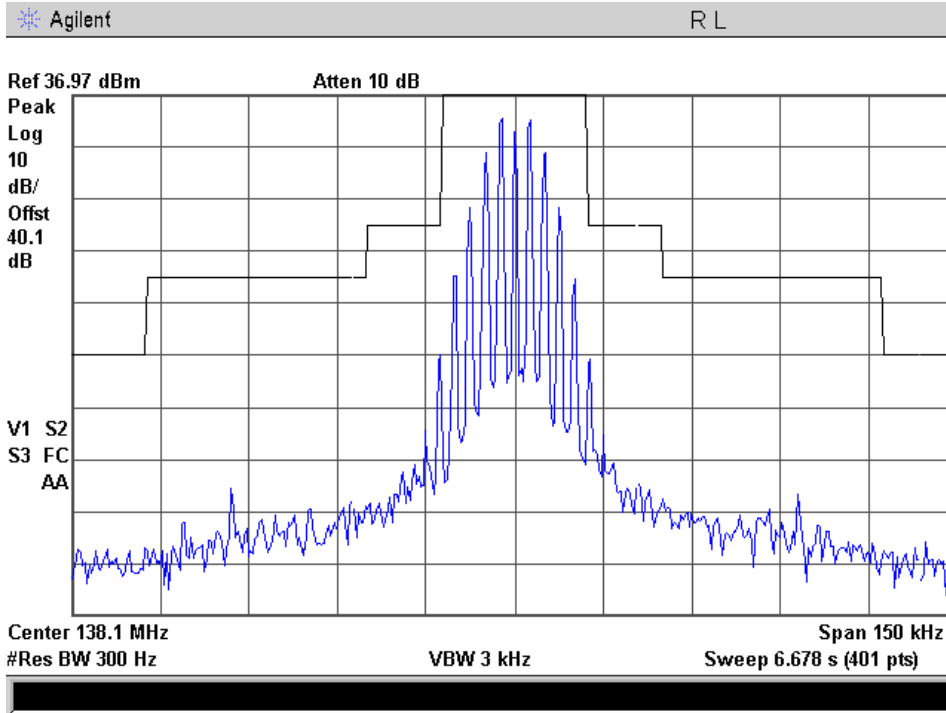

141.05 MHz (RSS-119 only)

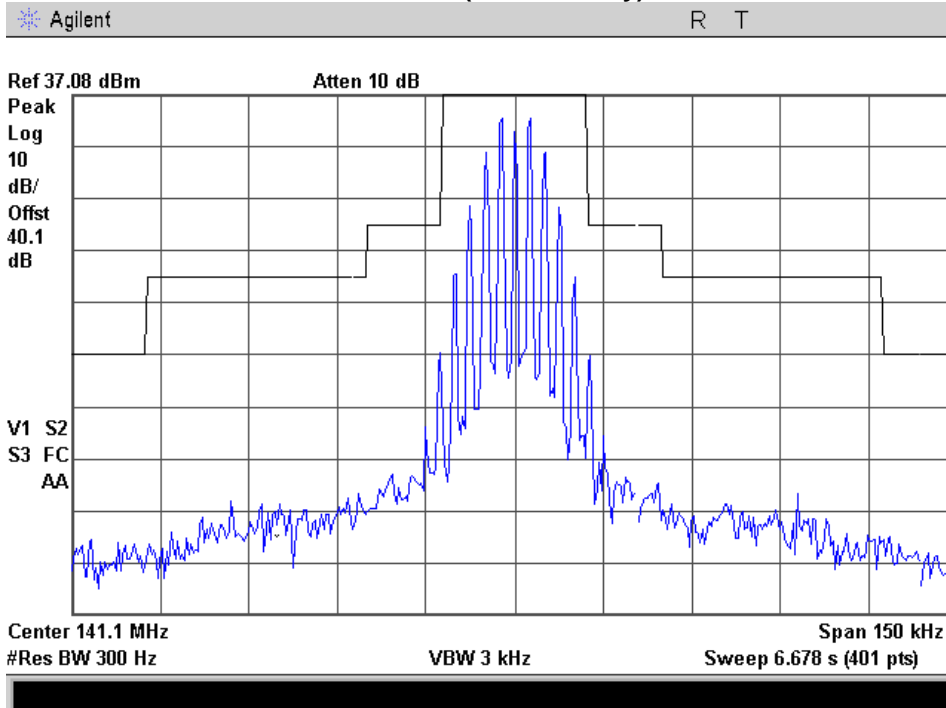



### 143.95 MHz (RSS-119 only)

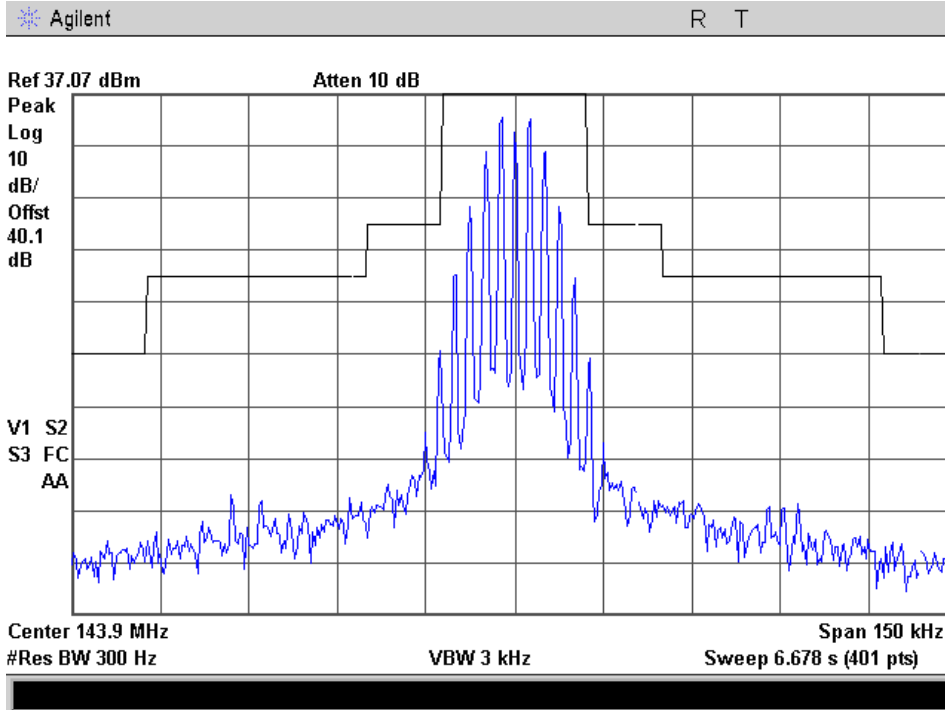

### 148.05 MHz (RSS-119 only)

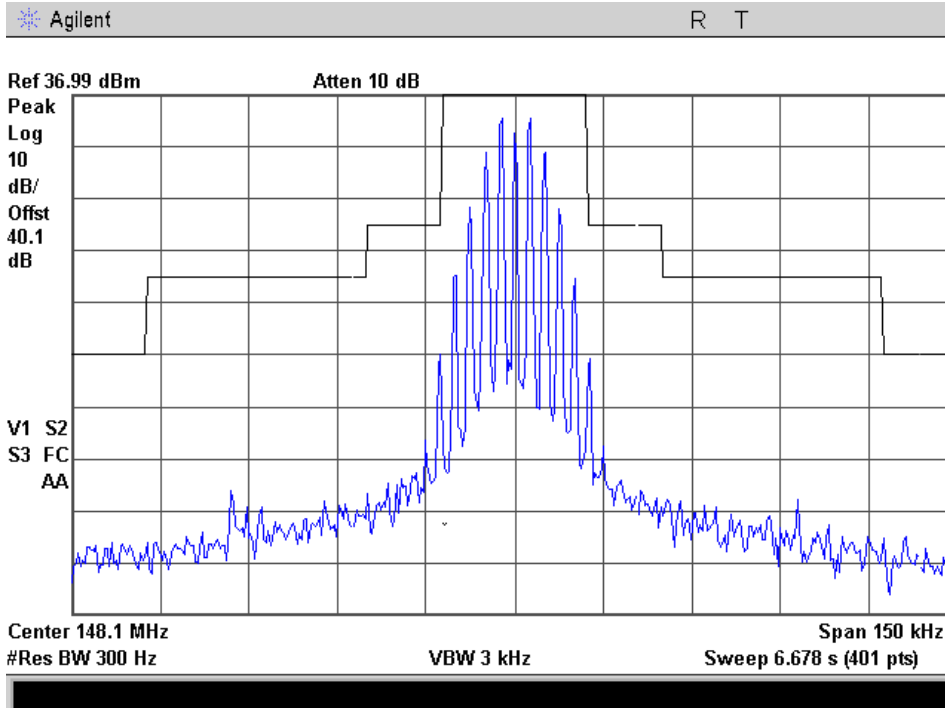





### 150.05 MHz (RSS-119 only)

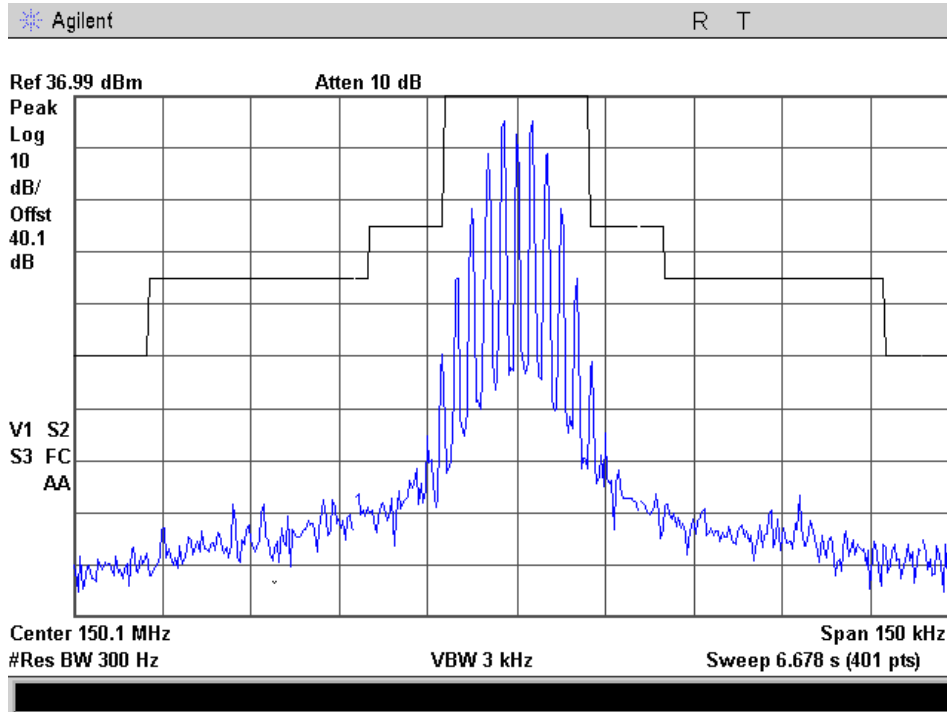

### 162.05 MHz (RSS-119 only)

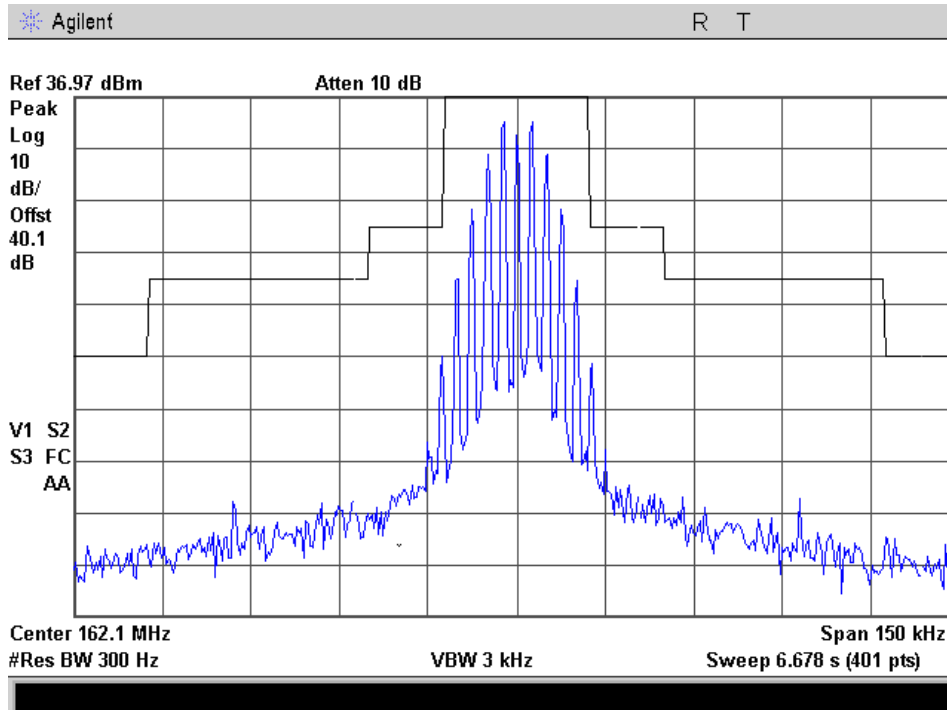



### 173.95 MHz (RSS-119 only)

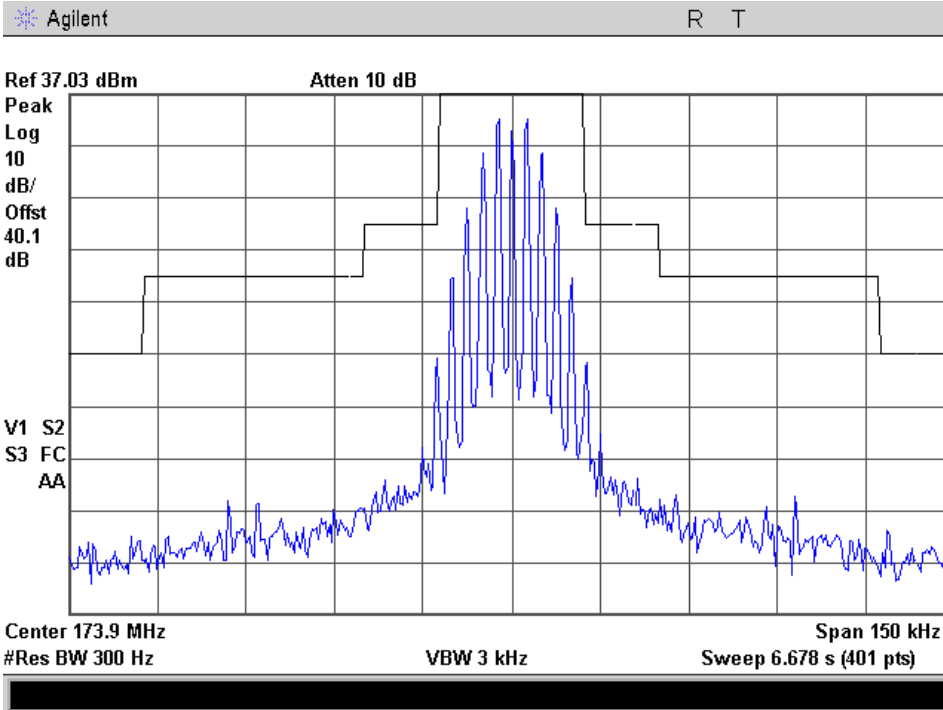



### Narrowband, Mask D Ch. BW = 12.5 KHz, Emission BW = 11K0

138.05 MHz (RSS-119 only)

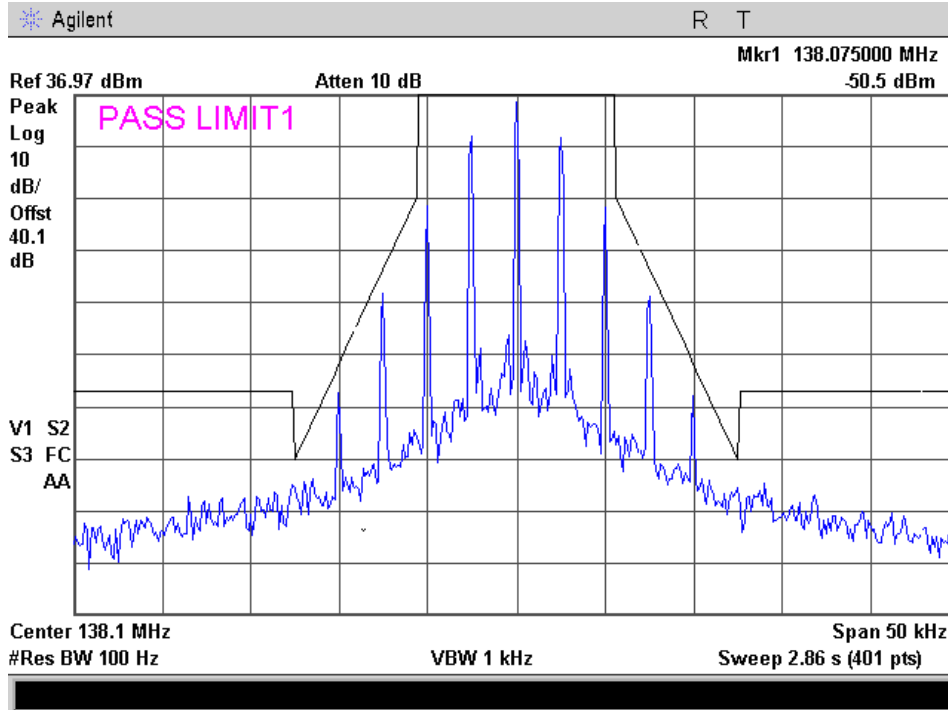

141.05 MHz (RSS-119 only)

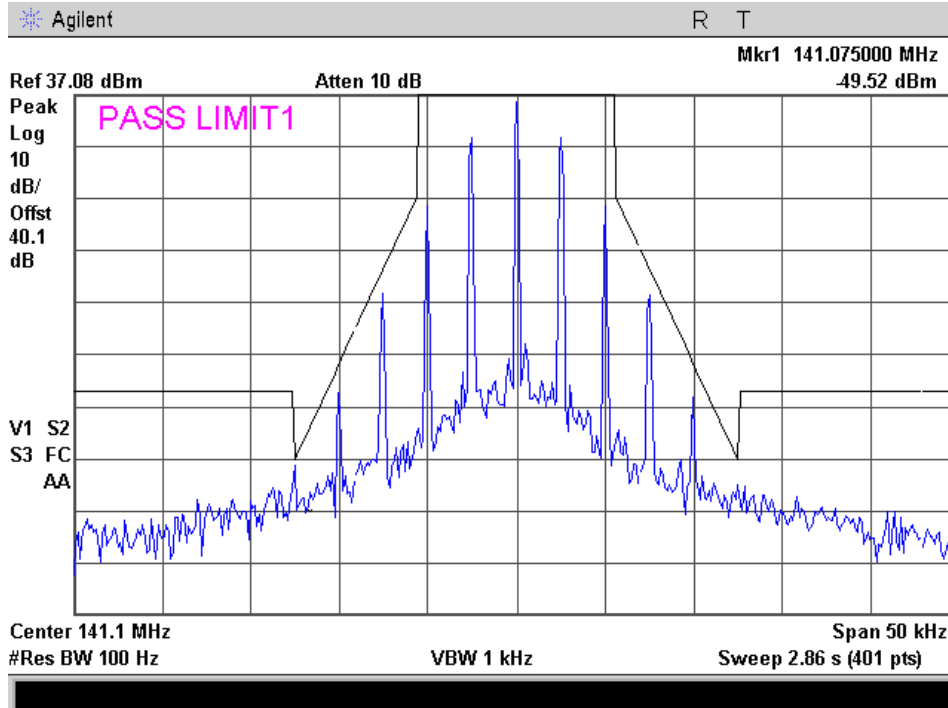



### 143.95 MHz (RSS-119 only)

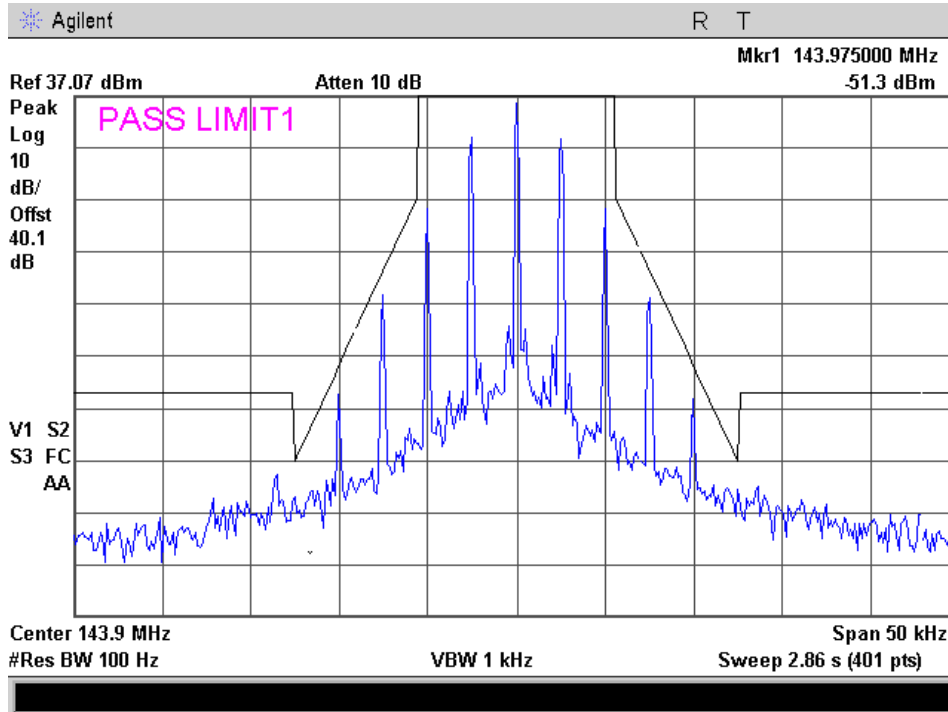

### 148.05 MHz (RSS-119 only)

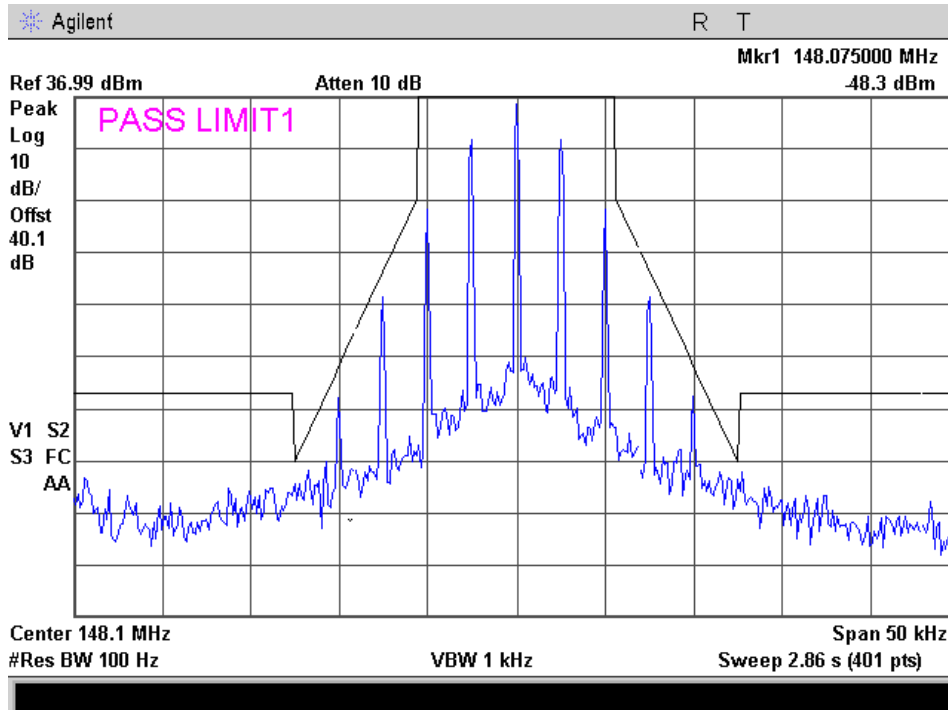



### 150.05 MHz

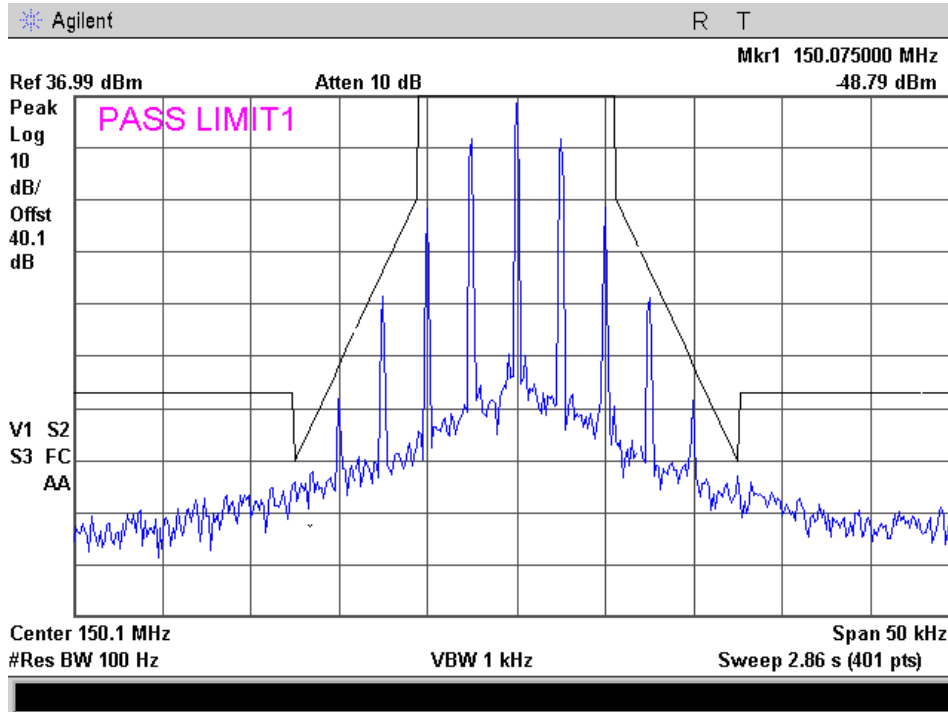

### 162.05 MHz

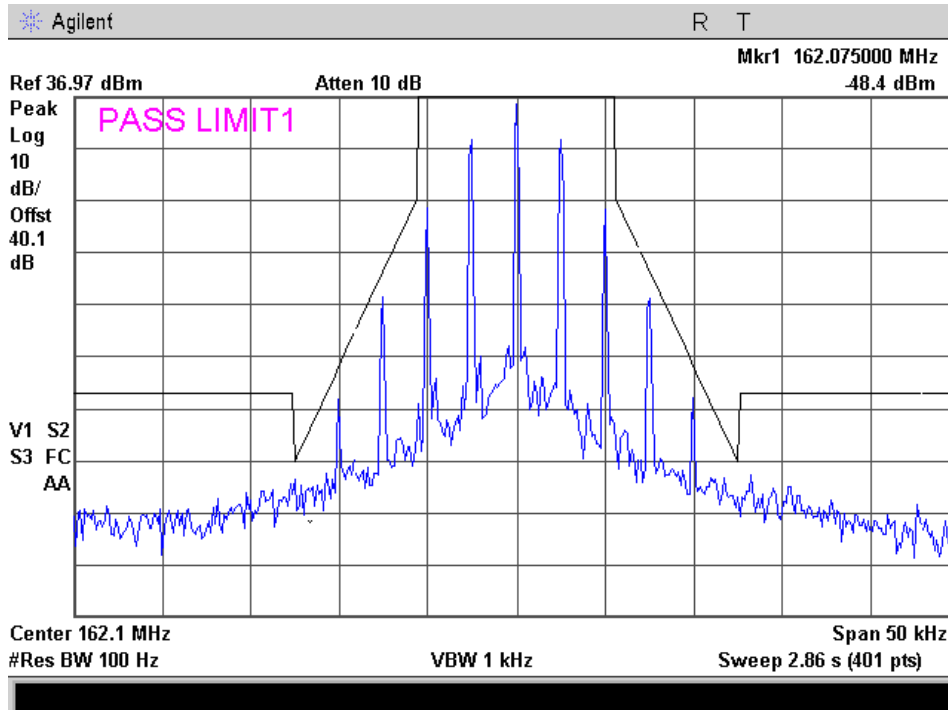



### 173.95 MHz

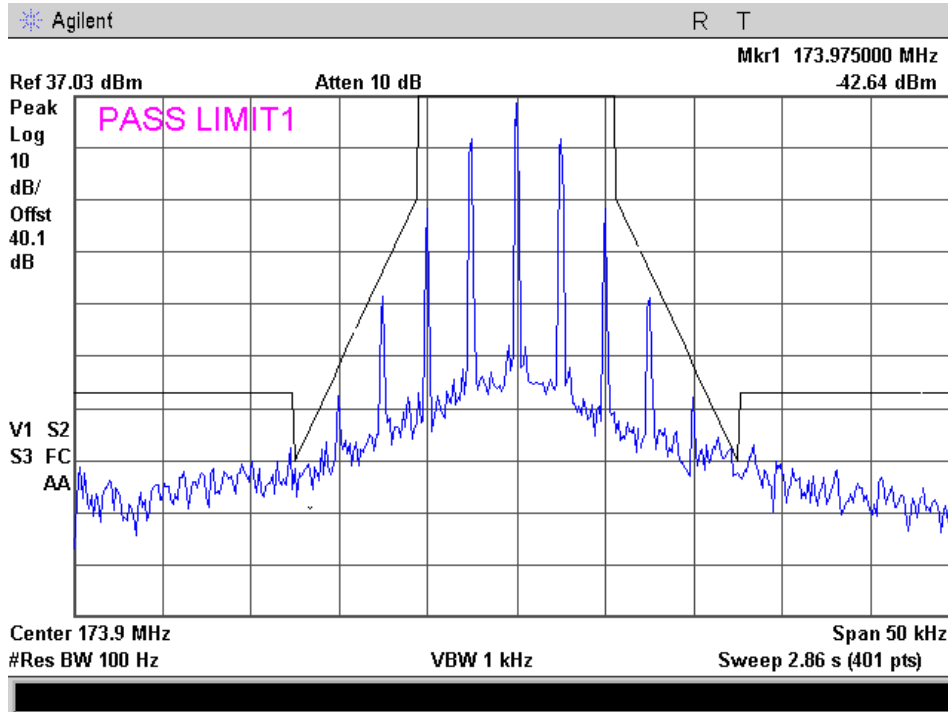



**Narrowband, Mask D**  
**Mixed Analog/Data**  
**Ch. BW = 12.5 KHz, Emission BW = 8K30**

**138.05 MHz (RSS-119 only)**

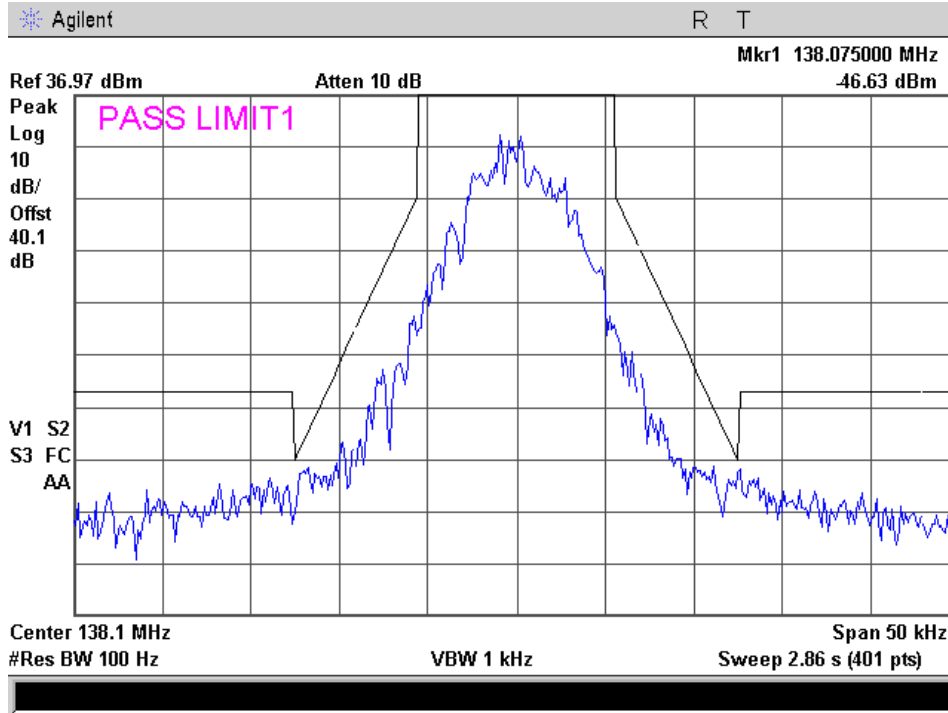

**141.05 MHz (RSS-119 only)**

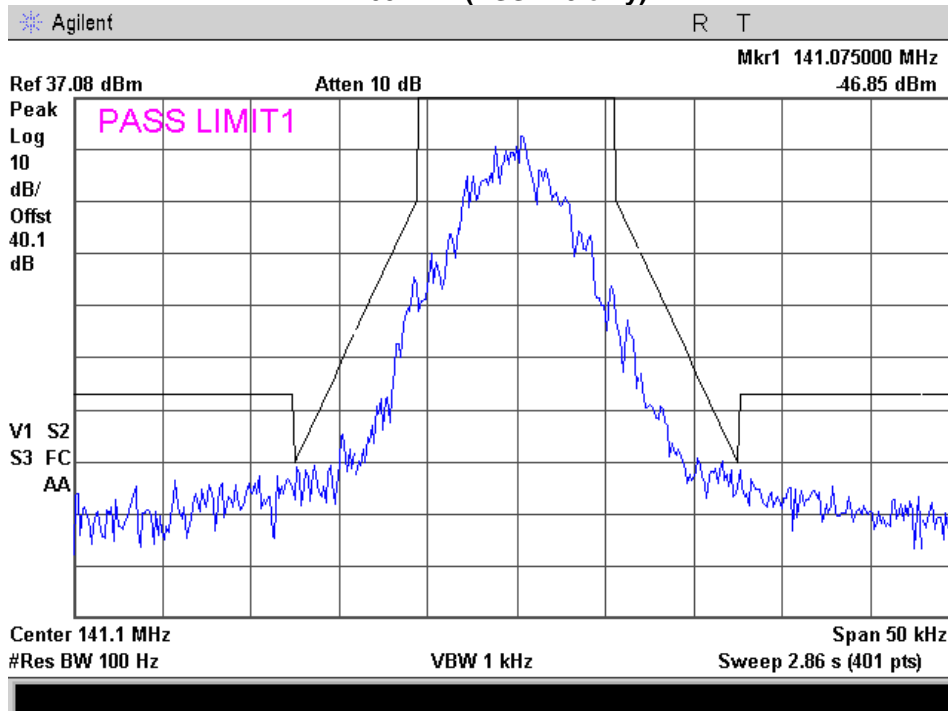



### 143.95 MHz (RSS-119 only)

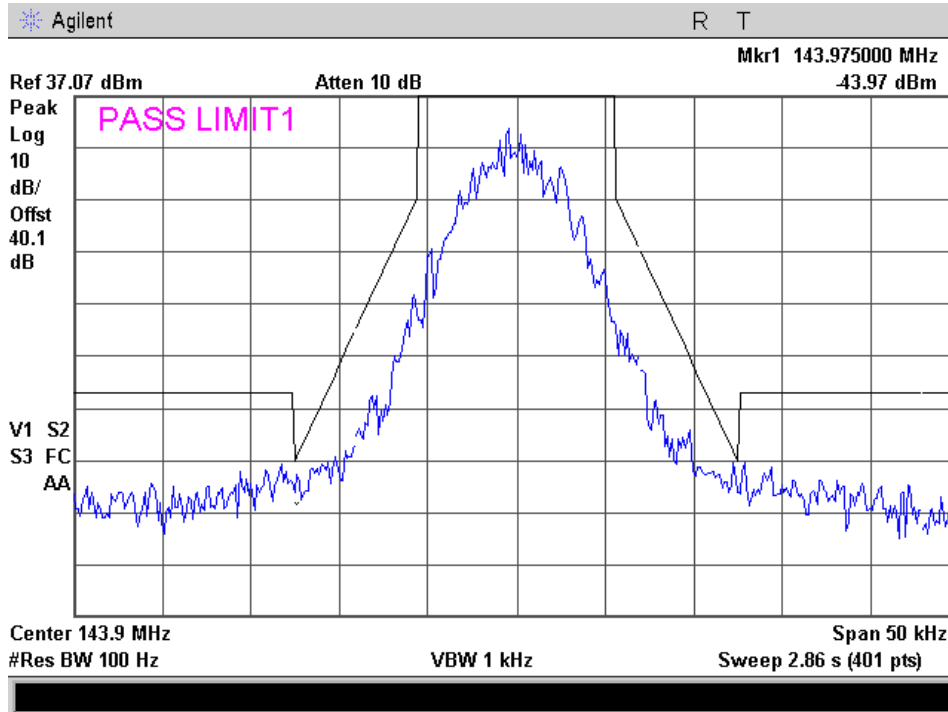

### 148.05 MHz (RSS-119 only)

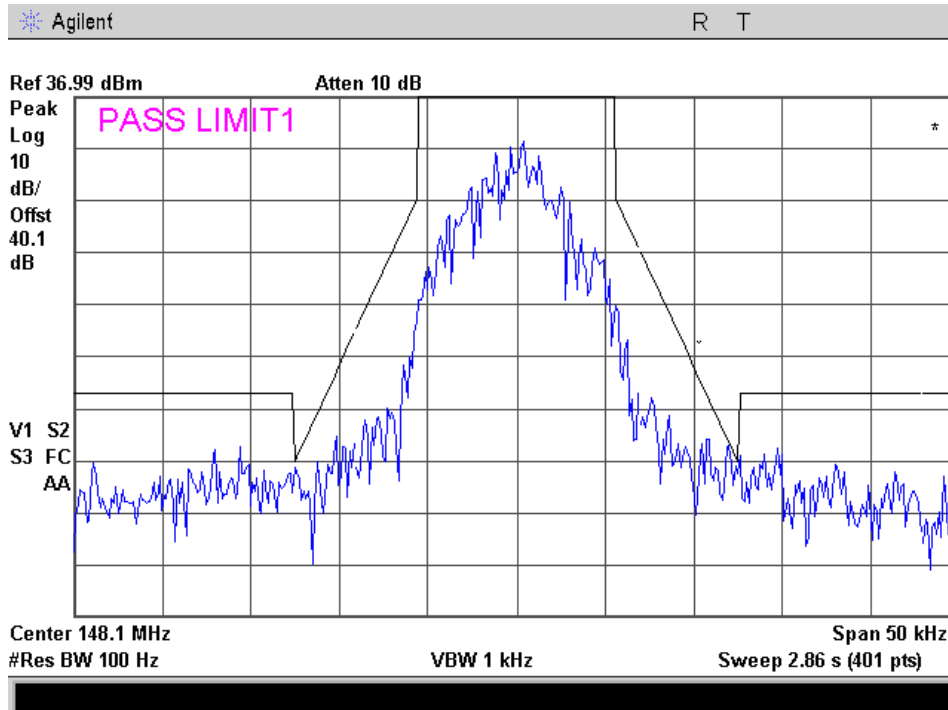





### 150.05 MHz

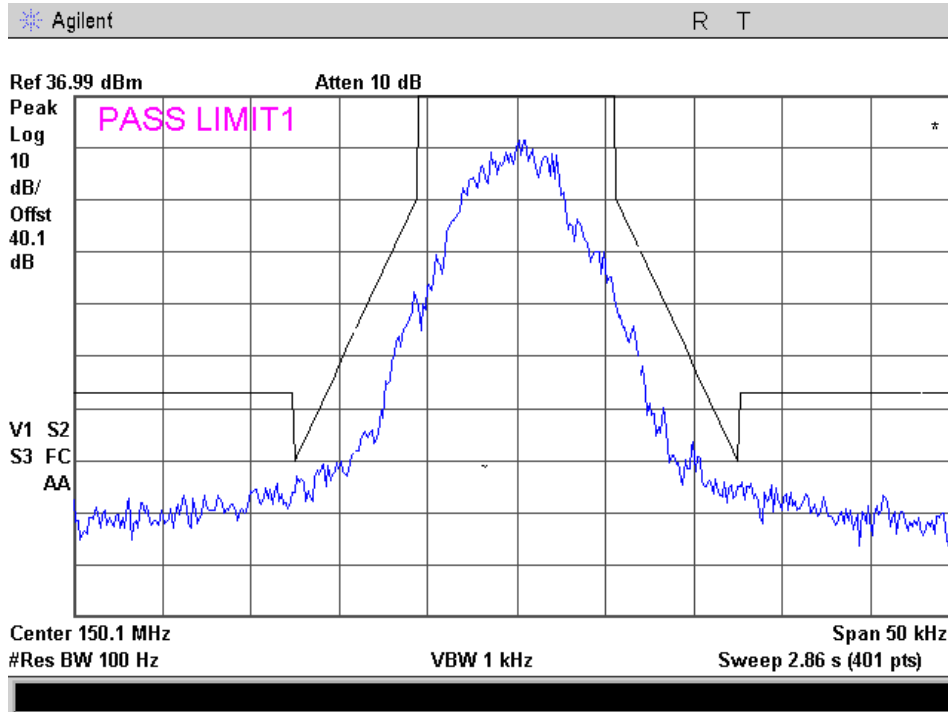

### 162.05 MHz

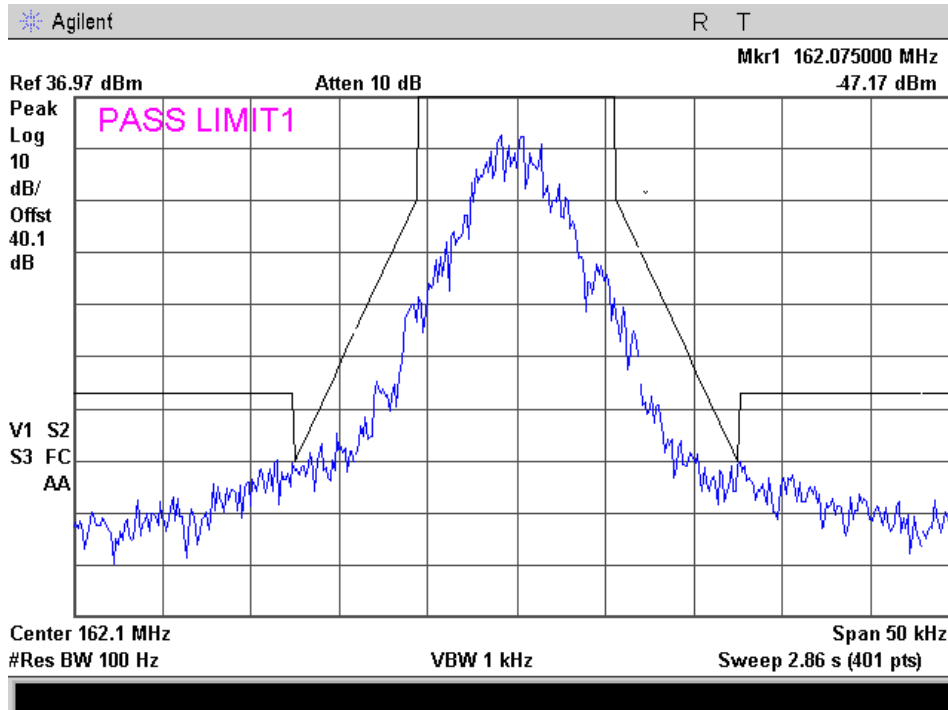



### 173.95 MHz

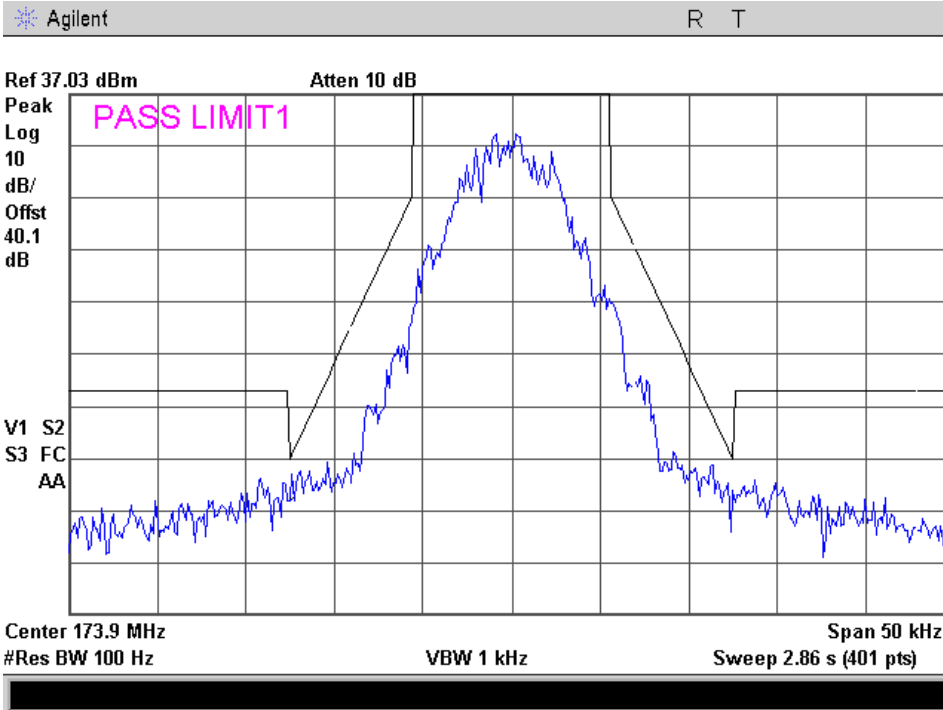



Very Narrowband, Mask E  
Mixed Analog/Data  
Ch. BW = 6.25 KHz, Emission BW = 4K00

138.05 MHz (RSS-119 only)

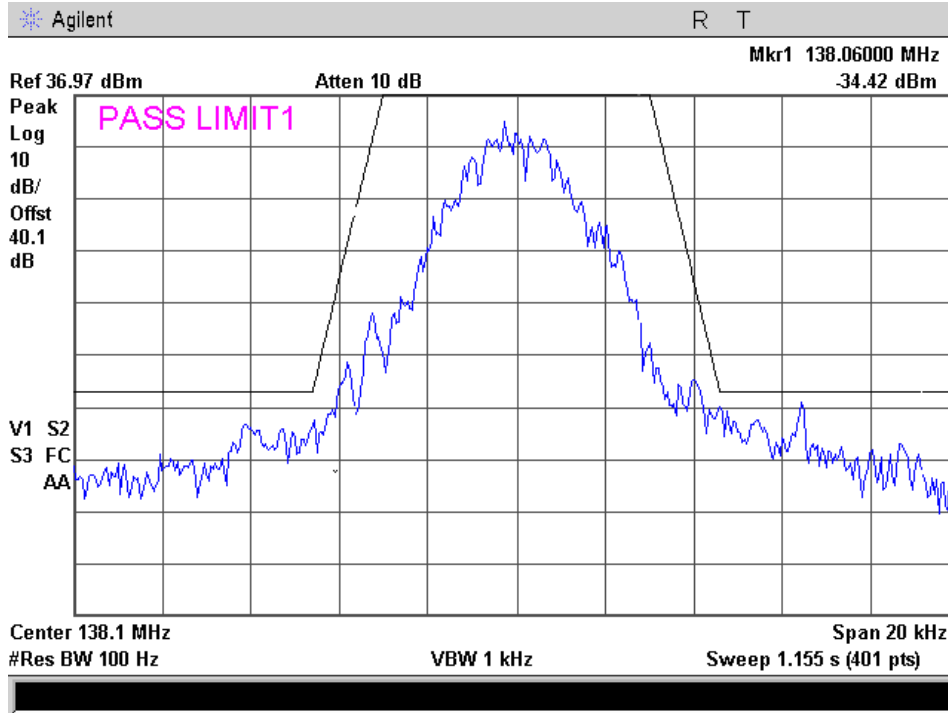

141.05 MHz (RSS-119 only)

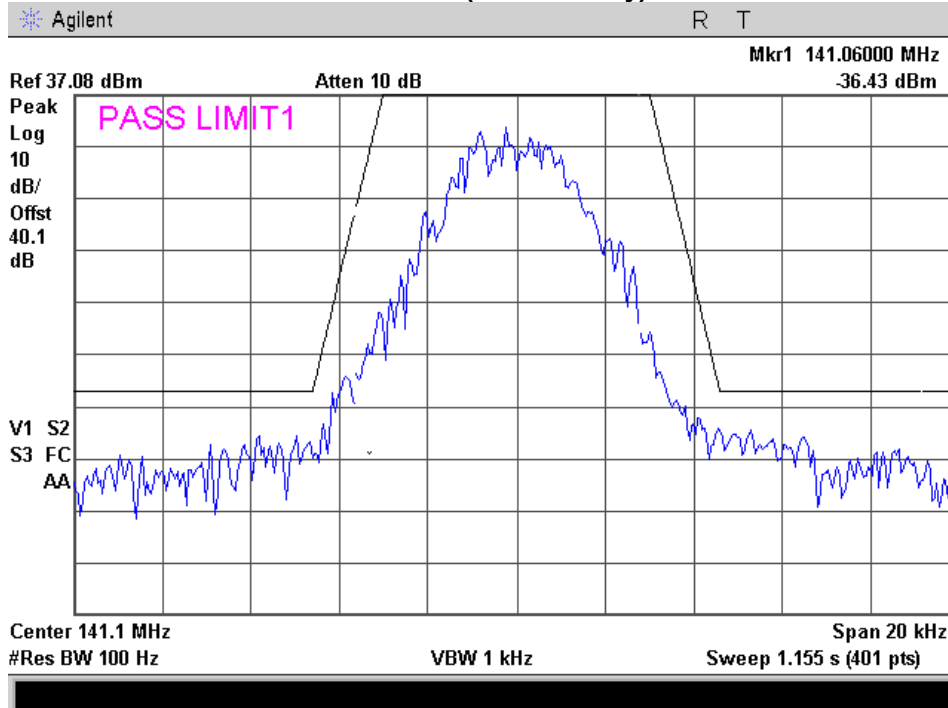



### 143.95 MHz (RSS-119 only)

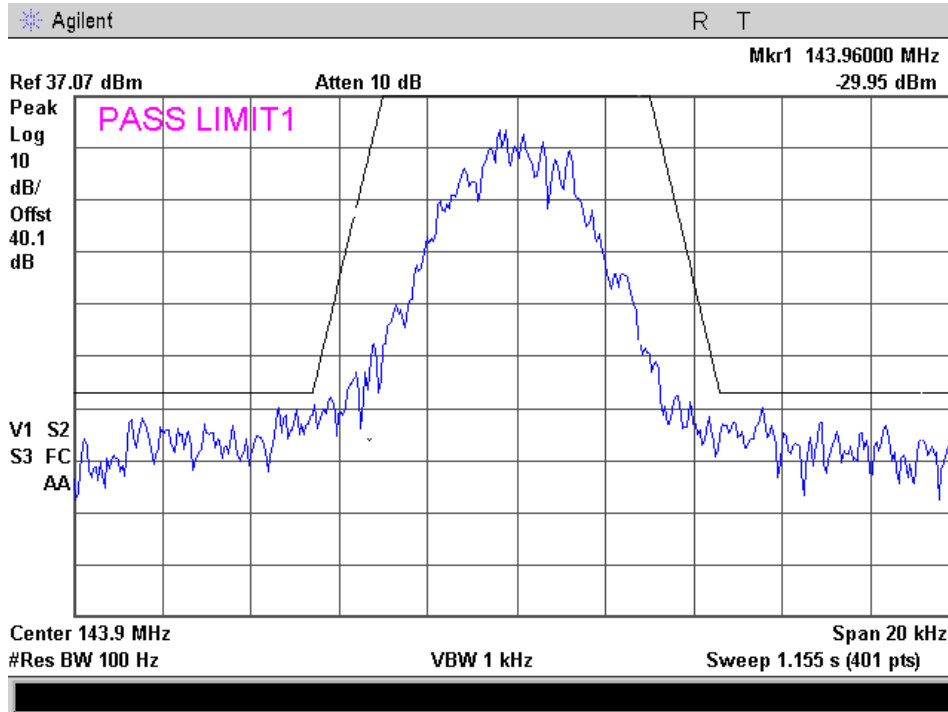

### 148.05 MHz (RSS-119 only)

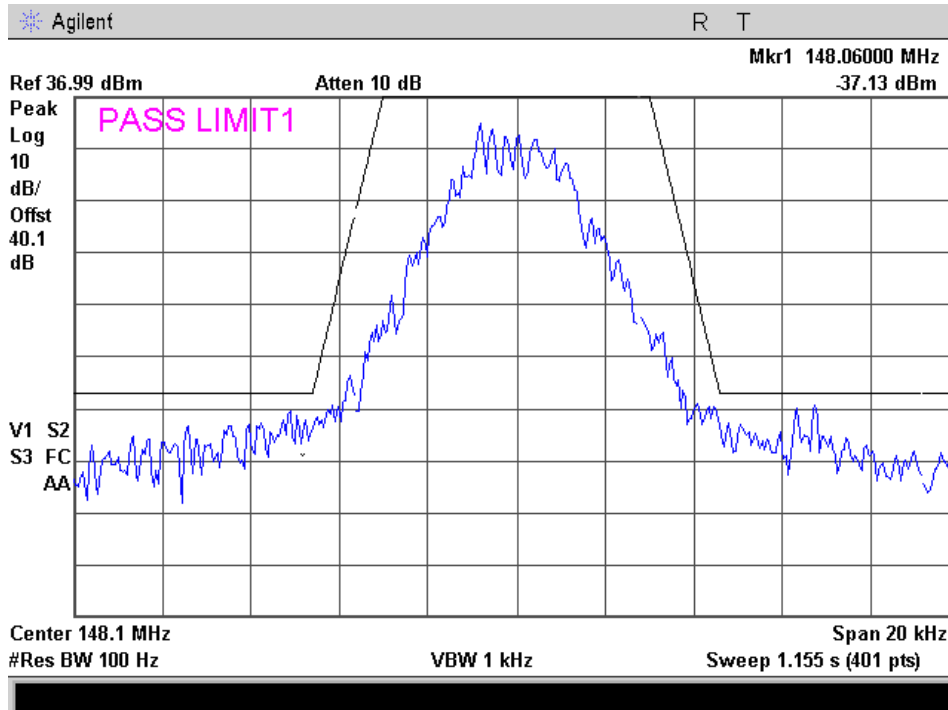



### 150.05 MHz

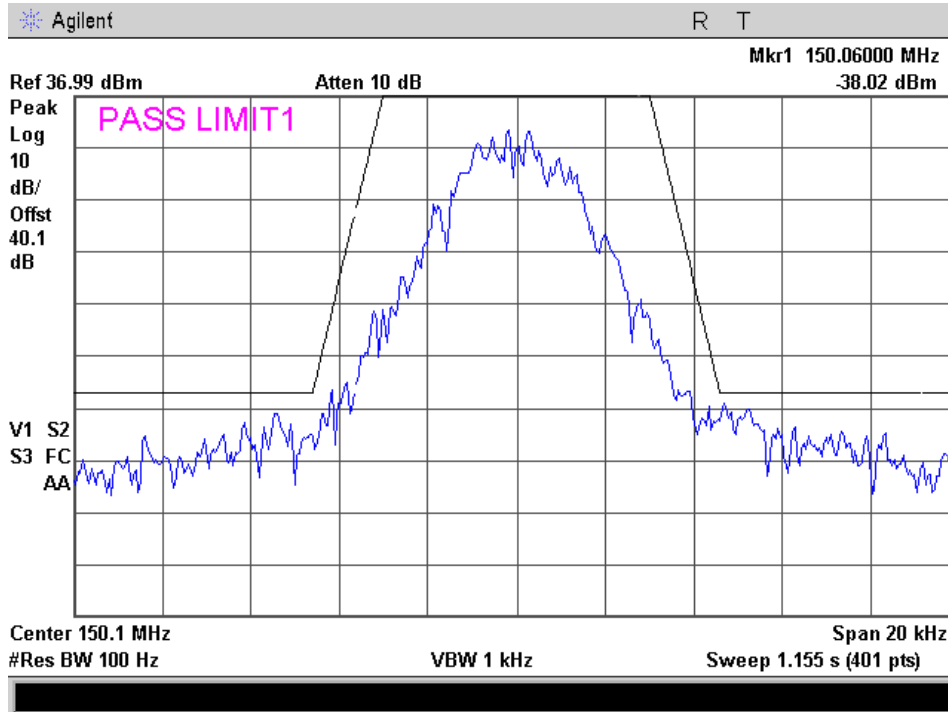

### 162.05 MHz

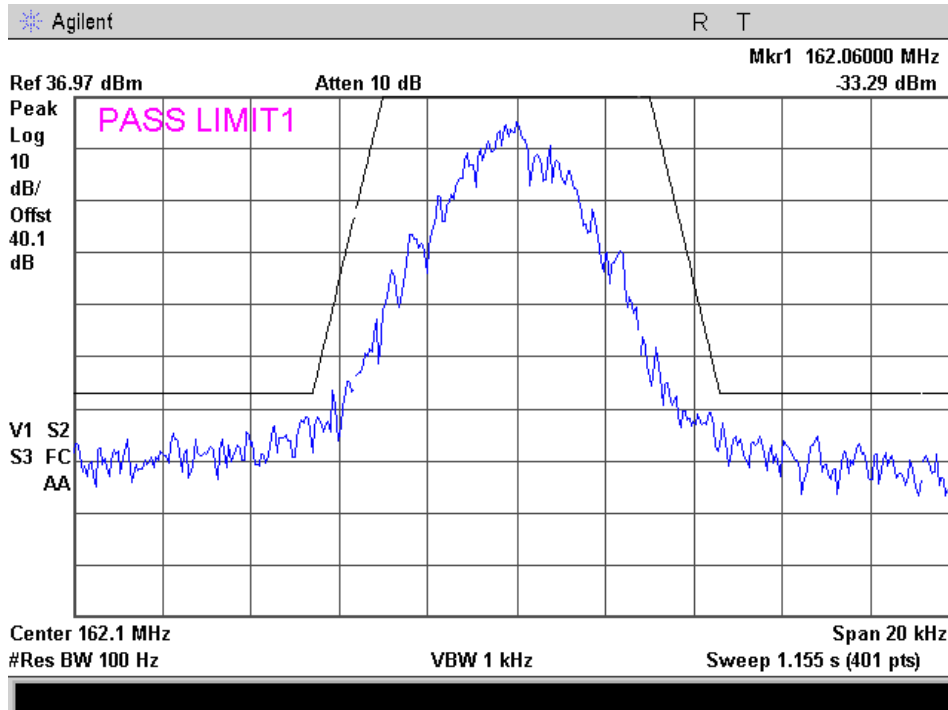



### 173.95 MHz

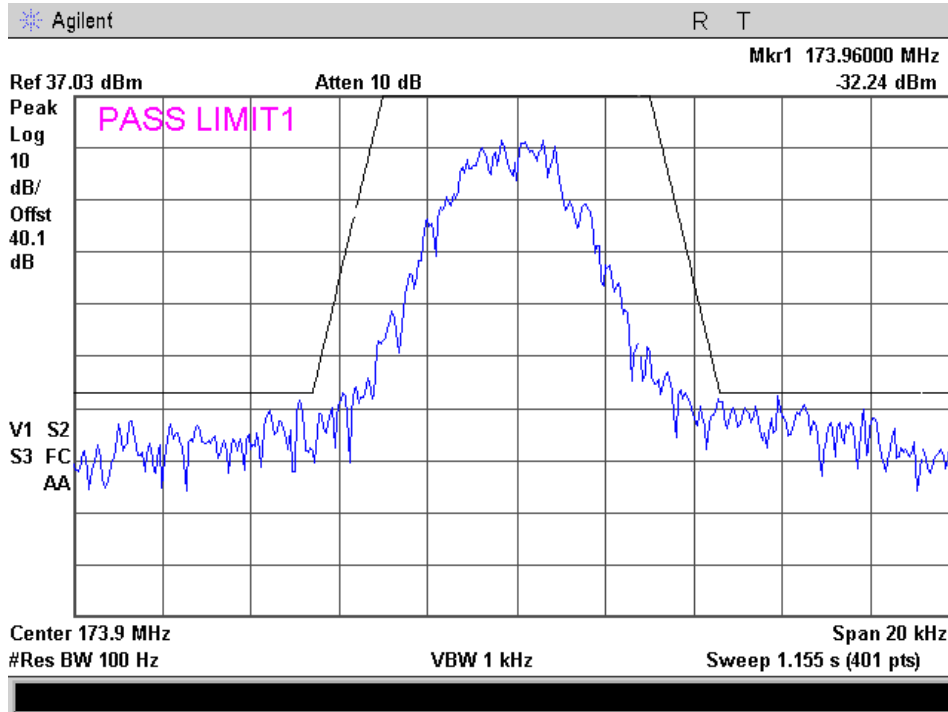

**Name of Test:** Transient Frequency Behavior  
**Specification:** 90.214  
**Test Equipment Utilized:** i00345

**Engineer:** G. Corbin  
**Test Date:** 12/22/2010

### Measurement Procedure

The EUT was connected directly to a Modulation Analyzer through a 40 dB attenuator to verify that the EUT meets the required Transient Frequency Behavior response per the specification. The modulation analyzer is a real time spectrum analyzer with integrated demodulation, audio measurement capabilities, and timing analysis. The turn on and turn off transient timing was measured and recorded.

### Test Setup

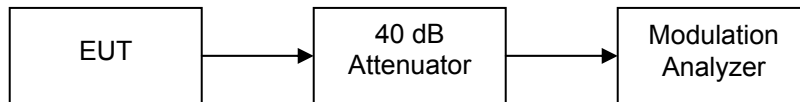



### Narrowband Test Results - On Time

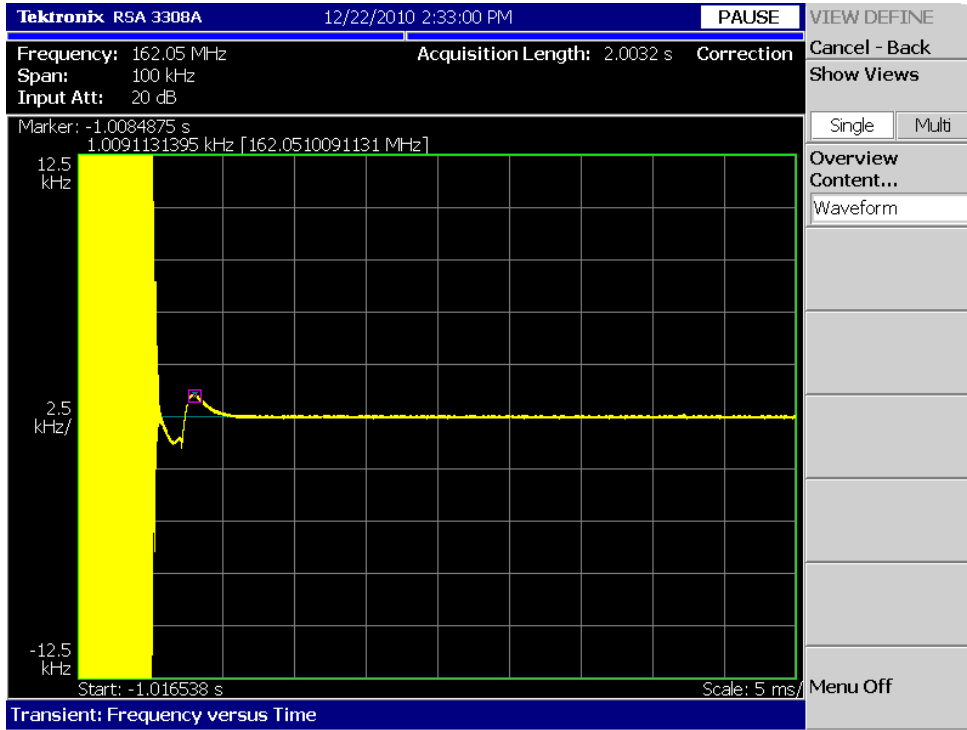

### Narrowband Test Results - Off Time

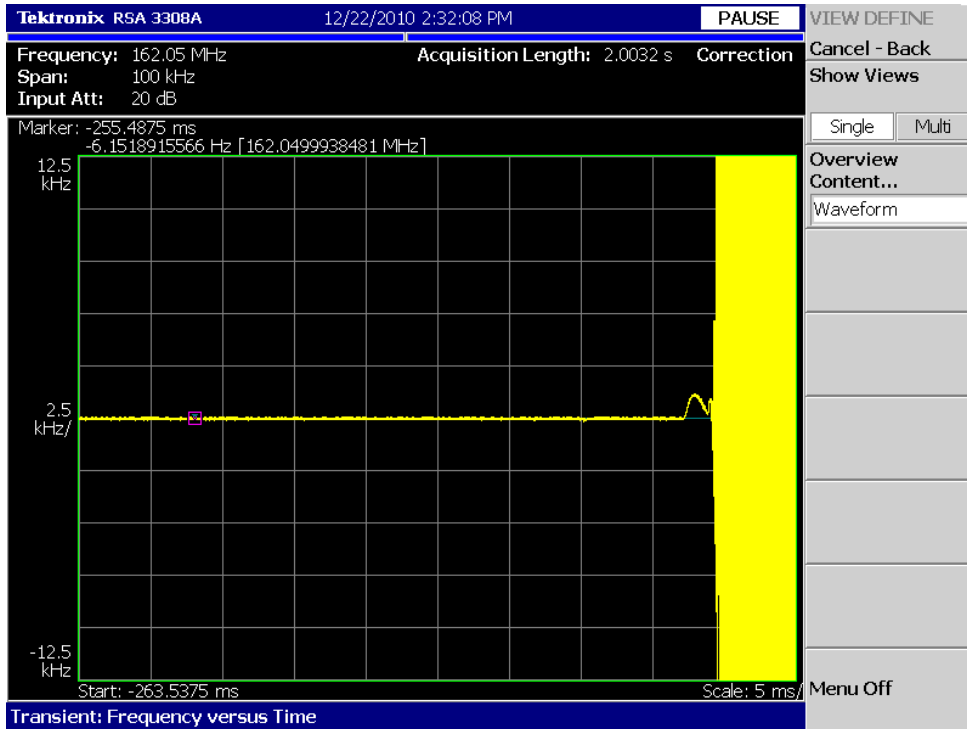





### Wideband Test Results - On Time - (RSS-119 only)

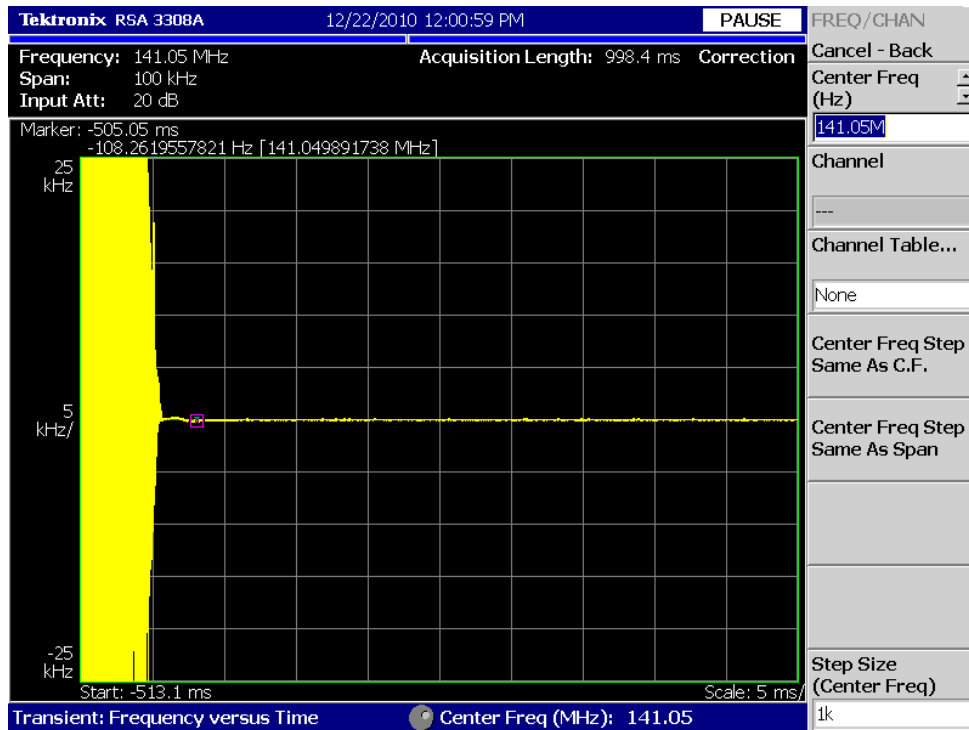

### Wideband Test Results - Off Time - (RSS-119 only)

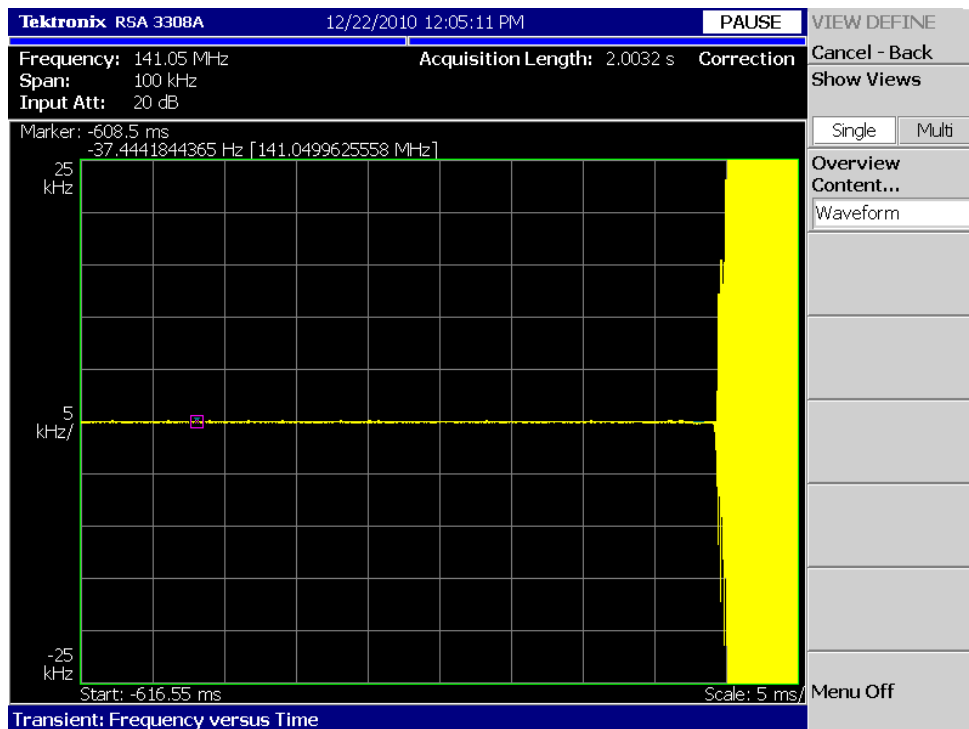

**Name of Test:** Audio Low Pass Filter (Voice Input)  
**Specification:** 2.1047  
**Test Equipment Utilized:** i00118, i00345

**Engineer:** G. Corbin  
**Test Date:** 12/22/2010

### Measurement Procedure

The EUT was connected directly to a Modulation Analyzer through an attenuator. The audio source was tuned across the required audio frequency range and the audio low pass filter response was measured and plotted. The modulation analyzer is a real time spectrum analyzer with integrated demodulation, audio measurement capabilities, and timing analysis.

### Test Set-Up

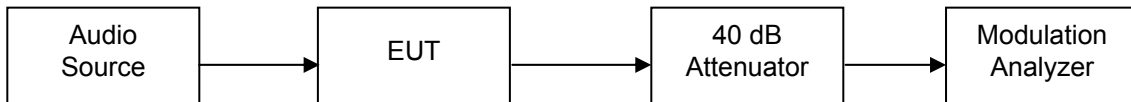

### Narrowband Test Results

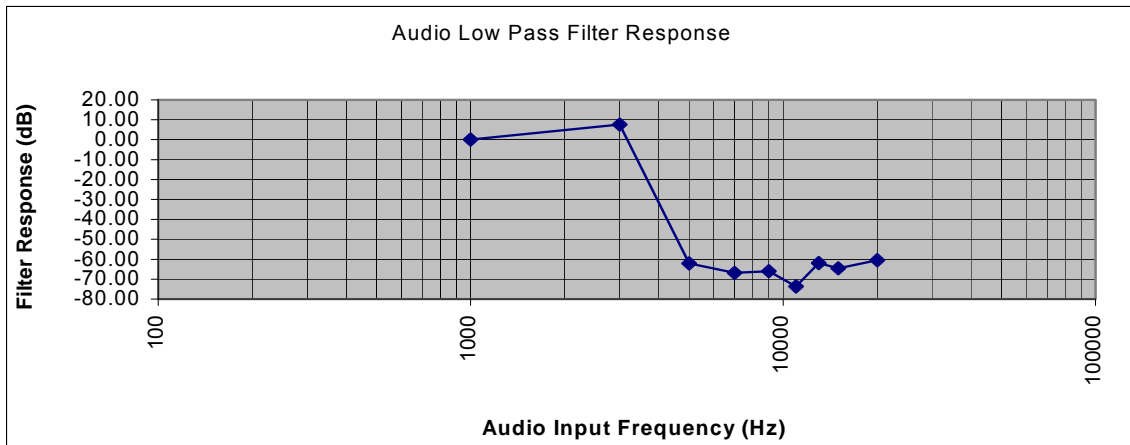

### Wideband Test Results (RSS-119 only)

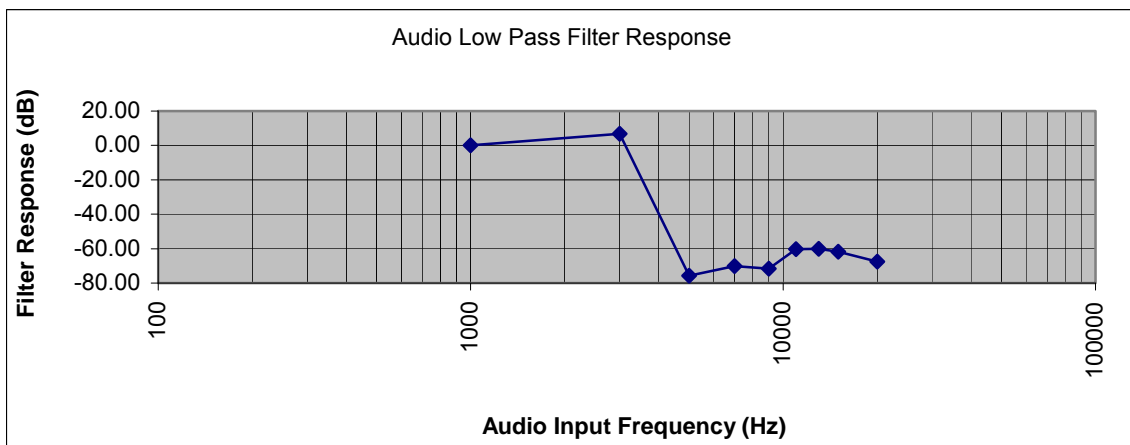

This unit is a digital radio and the roll-off for the filter is very linear in the operational band and sharp out of the band

**Name of Test:** Audio Frequency Response  
**Specification:** 2.1047  
**Test Equipment Utilized:** i00118, i00345

**Engineer:** G. Corbin  
**Test Date:** 12/22/2010

**Measurement Procedure**

The EUT was connected directly to a Modulation Analyzer through an attenuator. The audio source was tuned across the required audio frequency range and the audio frequency response was measured and plotted. The modulation analyzer is a real time spectrum analyzer with integrated demodulation, audio measurement capabilities, and timing analysis.

**Test Set-Up**

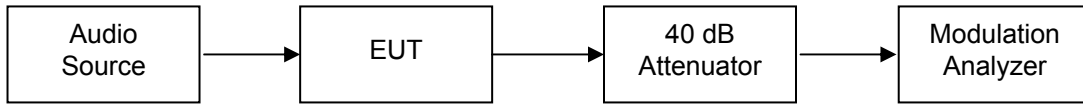

**Narrowband Test Results**

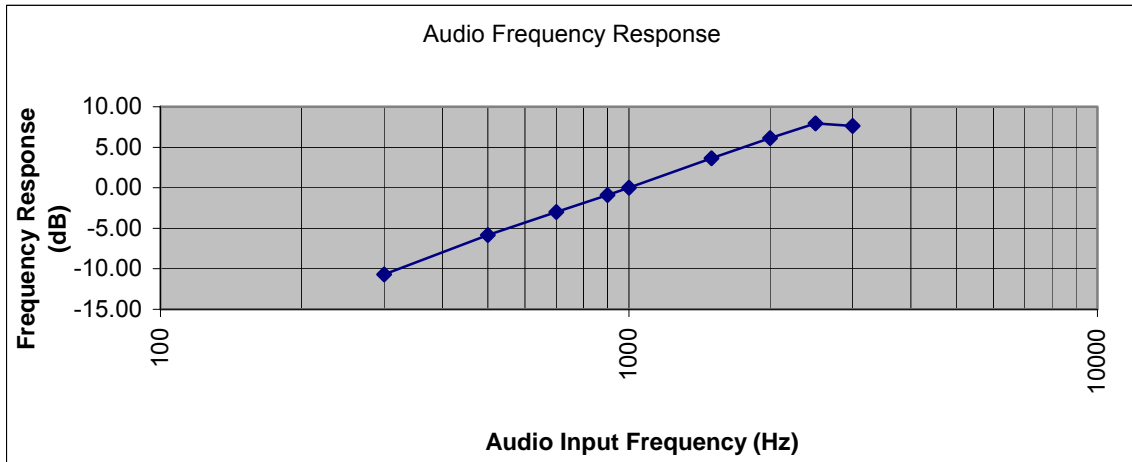

**Wideband Test Results**

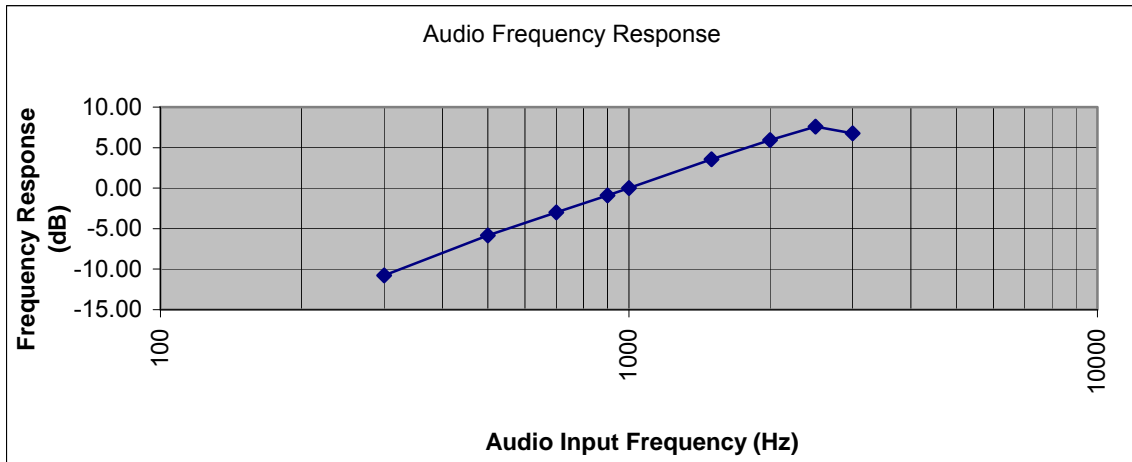

**Name of Test:** Modulation Limiting  
**Specification:** 2.1047(a)  
**Test Equipment Utilized:** i00118, i00345

**Engineer:** G. Corbin  
**Test Date:** 12/22/2010

### Measurement Procedure

The EUT was connected directly to a Modulation Analyzer through an attenuator. The audio source was tuned across the required audio frequency range and the modulation limiting response was measured and plotted. The modulation analyzer is a real time spectrum analyzer with integrated demodulation, audio measurement capabilities, and timing analysis.

### Test Set-Up

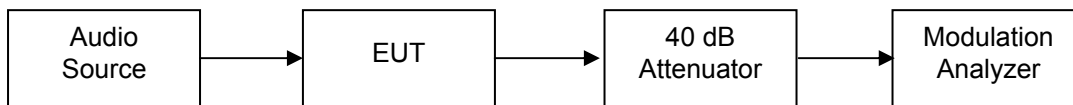



### Narrowband Positive Peaks

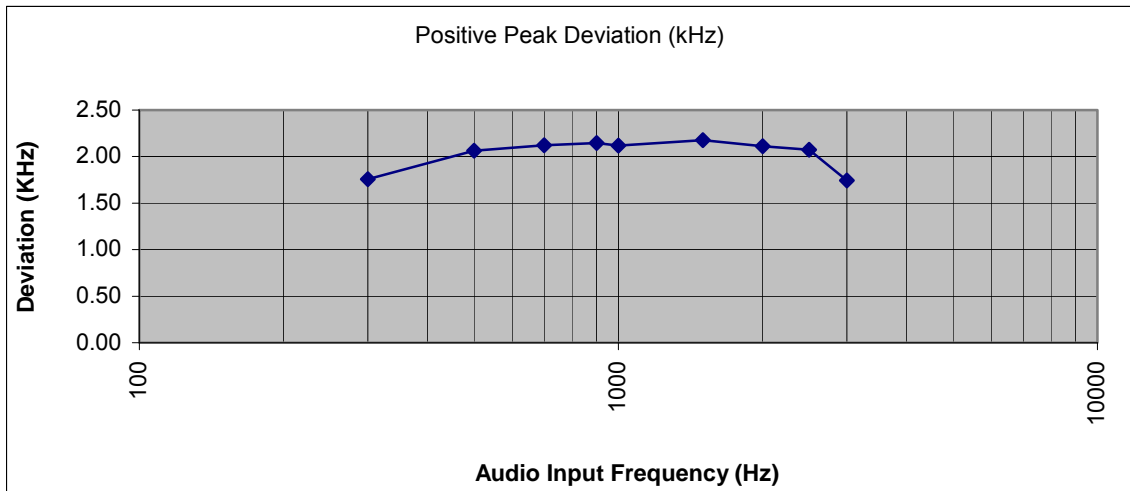

### Narrowband Negative Peaks

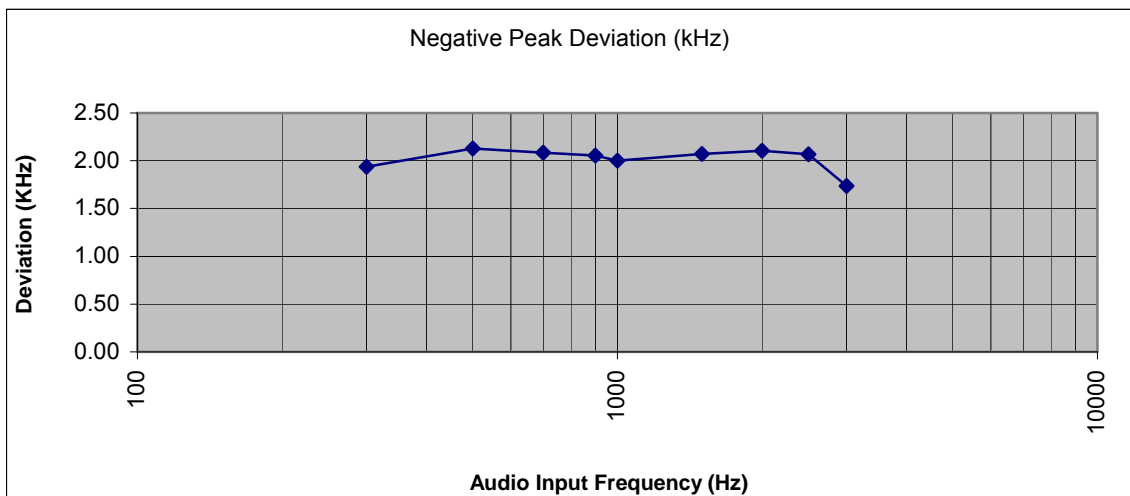



### Wideband Positive Peaks - (RSS-119 only)

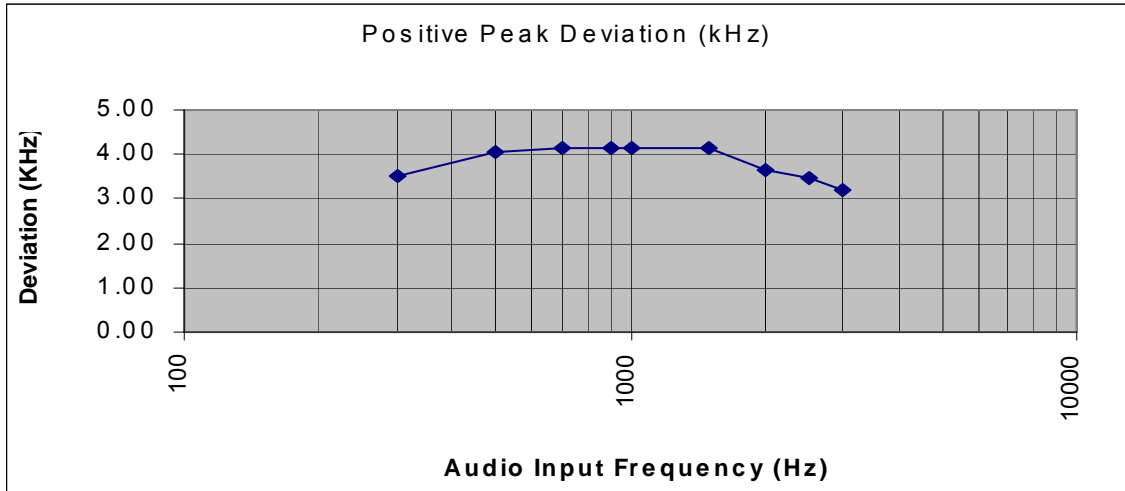

### Wideband Negative Peaks - (RSS-119 only)

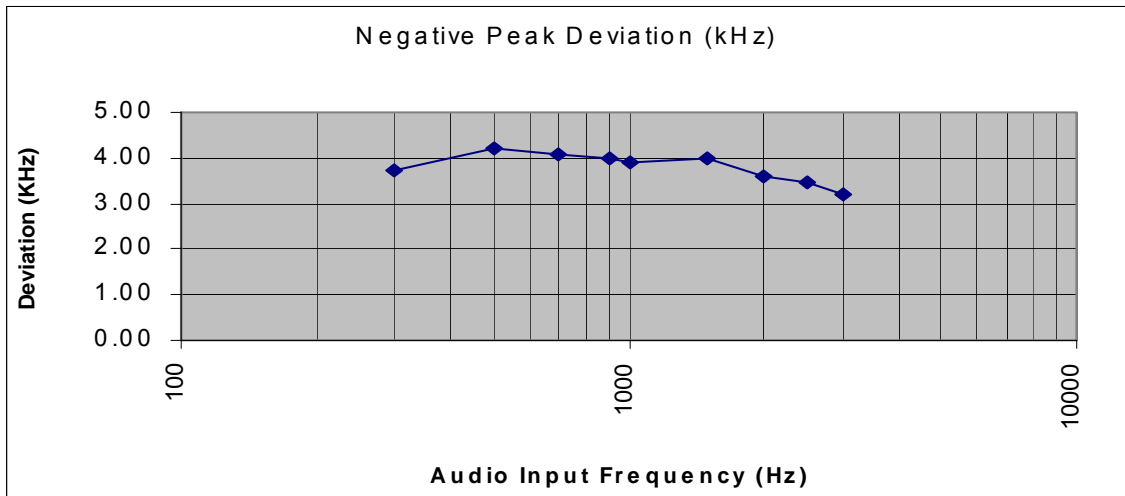

**Name of Test:** Frequency Stability (Temperature Variation)  
**Specification:** 90.213 **Engineer:** G. Corbin  
**Test Equipment Utilized:** i00019, i00191, i00287, i00320, i00343 **Test Date:** 12/28/2010

### Measurement Procedure

The EUT was placed in an environmental test chamber and the RF output was connected directly to a frequency counter. The temperature was varied from -30°C to 50°C in 10°C increments. After a sufficient time for temperature stabilization the RF output frequency was measured.

### Measurement Setup

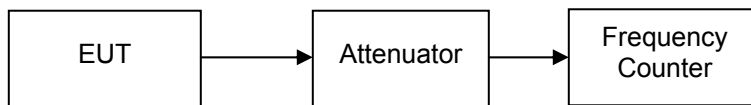

### Measurement Results

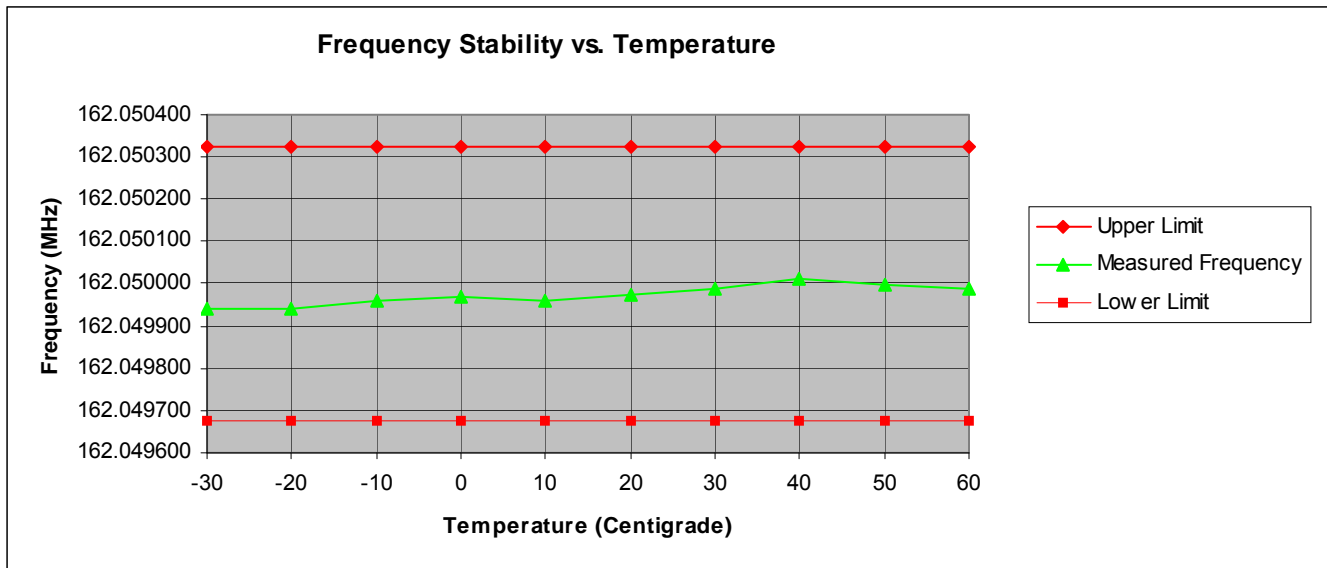

**Name of Test:** Frequency Stability (Voltage Variation)  
**Specification:** 90.213  
**Test Equipment Utilized:** i00019, i00191, i00287, i00320, i00343  
**Engineer:** G. Corbin  
**Test Date:** 12/28/2010

### Measurement Procedure

The EUT was placed in a temperature chamber at  $25\pm 5^{\circ}\text{C}$  and connected directly to a frequency counter and variable power supply. The power supply voltage to the EUT was varied from 85% to 115% of the nominal value and the RF output was measured.

### Measurement Setup

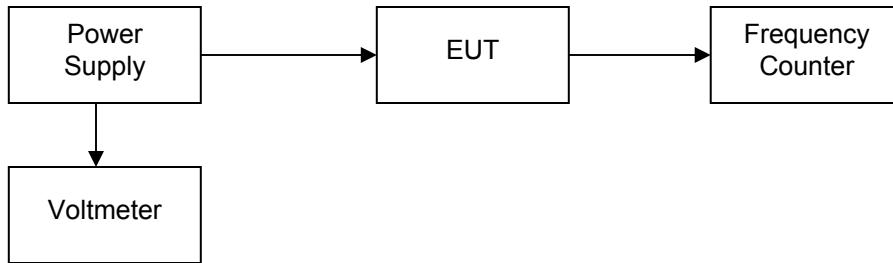

### Measurement Results

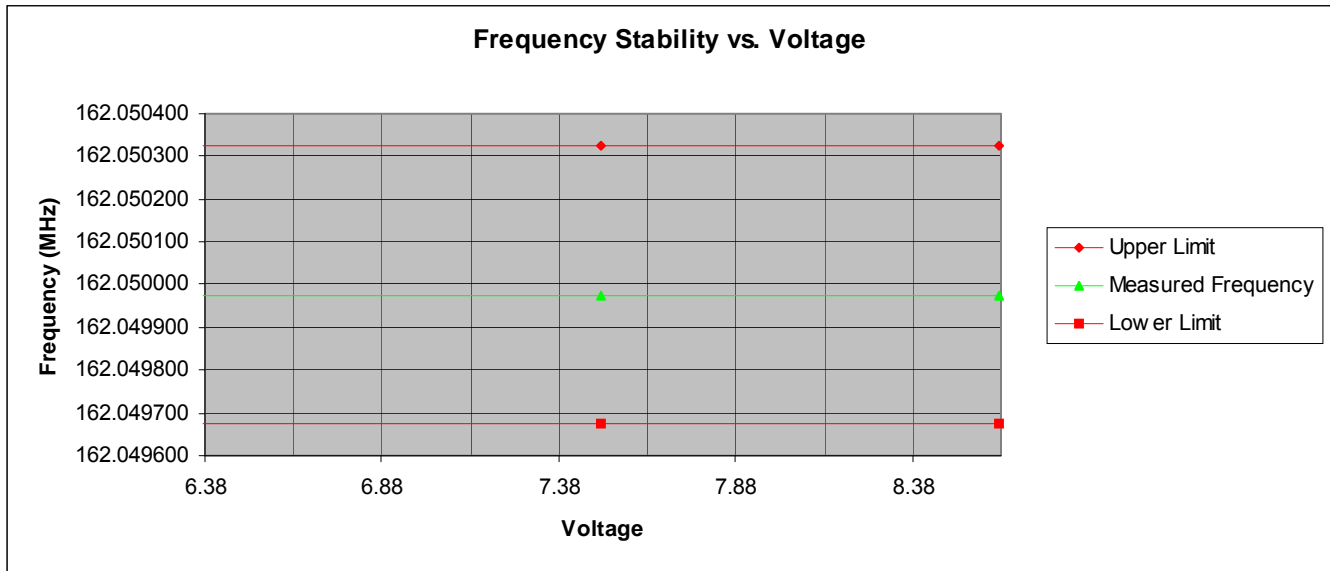



**Name of Test:** Receiver Spurious Emissions  
**Specification:** RSS-GEN  
**Test Equipment Utilized:** i00331

**Engineer: G. Corbin**  
**Test Date: 12/22/2010**

### Test Procedure

The Equipment Under Test (EUT) was connected directly to a Spectrum analyzer. The cable loss was input into the analyzer as a reference level offset to ensure accurate readings.

### Test Setup

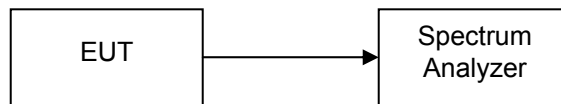



### Tuned Frequency = 141.05 MHz

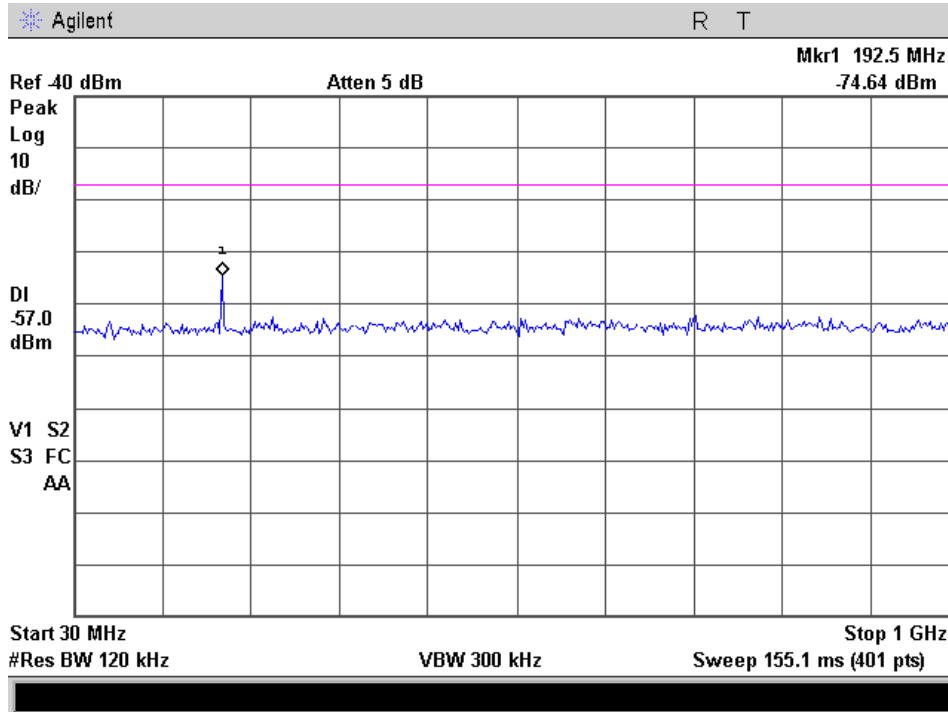

### Tuned Frequency = 162.05 MHz

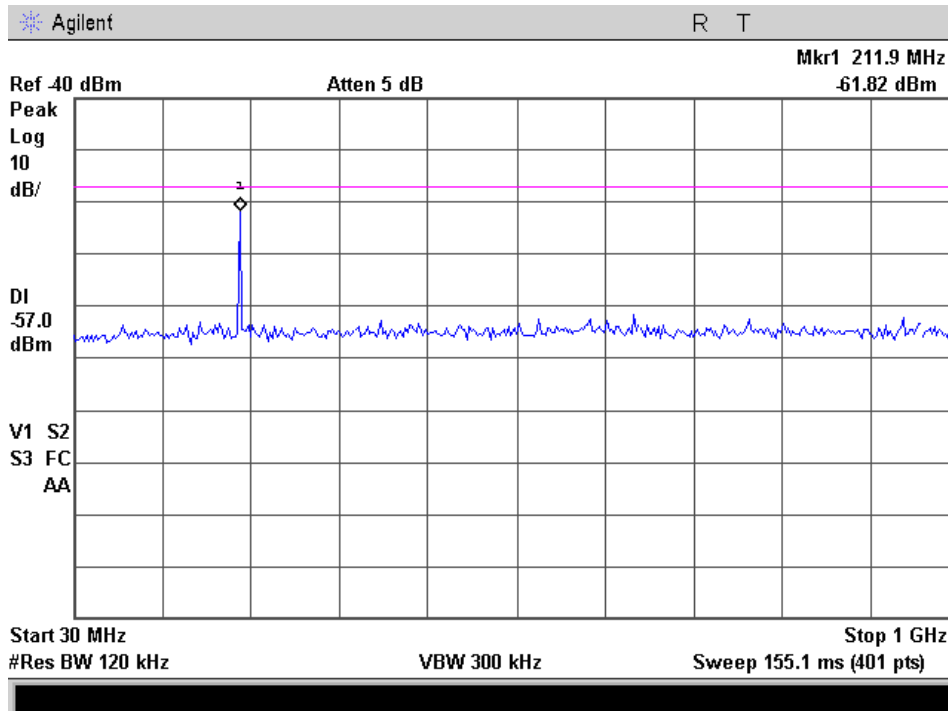



**Name of Test:** Necessary Bandwidth Calculations  
**Specification:** 2.202  
**Test Equipment Utilized:** N/A

**Engineer:** G. Corbin  
**Test Date:** 12/29/2010

Modulation = 11K0F3E (12.5 kHz channel BW)

**Necessary Bandwidth Calculation:**

Maximum Modulation (M), kHz = 3  
 Maximum Deviation (D), kHz = 2.5  
 Constant Factor (K) = 1  
 Necessary Bandwidth (B<sub>N</sub>), kHz = (2xM)+(2xDxK)  
 = 11.0

Modulation = 16K0F3E (RSS-119 only) (25 kHz channel BW)

**Necessary Bandwidth Calculation:**

Maximum Modulation (M), kHz = 3  
 Maximum Deviation (D), kHz = 5  
 Constant Factor (K) = 1  
 Necessary Bandwidth (B<sub>N</sub>), kHz = (2xM)+(2xDxK)  
 = 16.0

Modulation = 8K30F1E, 8K30F1D, 8K30F7W  
 (4 level FSK, 9600 bps, 12.5 kHz channel BW)

**Necessary Bandwidth Calculation:**

Data Rate (R) bps = 9600  
 Maximum Deviation (D), kHz = 3.391  
 Signaling States = 4  
 Constant Factor (K) = 0.516  
 Necessary Bandwidth (B<sub>N</sub>), kHz = (R/log<sub>2</sub>S)+2DK  
 B<sub>n</sub> = 8.3 kHz

Modulation = 4K00F1E, 4K00F1D, 4K00F7W  
 (4 level FSK, 4800 bps, 6.25 kHz channel BW)

**Necessary Bandwidth Calculation:**

Data Rate (R) bps = 4800  
 Maximum Deviation (D), kHz = 1.550  
 Signaling States = 4  
 Constant Factor (K) = 0.516  
 Necessary Bandwidth (B<sub>N</sub>), kHz = (R/log<sub>2</sub>S)+2DK  
 B<sub>n</sub> = 4.0 kHz

Modulation =4K00F2D  
 (CWID, 6.25 kHz channel BW)

**Necessary Bandwidth Calculation:**

Maximum Modulation (M), kHz = 0.8  
 Maximum Deviation (D), kHz = 1.2  
 Constant Factor (K) = 1  
 Necessary Bandwidth (B<sub>N</sub>), kHz = (2xM)+(2xDxK)  
 B<sub>n</sub> = 4.0 kHz



### Test Equipment Utilized

Description	MFG	Model Number	CT Asset Number	Last Cal Date	Cal Due Date
Frequency Counter	HP	5334B	i00019	2/15/2010	2/15/2011
EMI Receiver	HP	8546A	i00033	12/3/2010	12/3/2011
Monopole Antenna Set	Ailtech	DM-105A-T1, T2, T3	i0003, 39, 42, 48	Verify	When used
Function Generator	HP	33120A	i00118	Verify	When used
Tunable Notch Filter	Eagle	TNF-1 (100-500MHz)	i00126	Verify	When used
Power Supply	HP	6673A	i00191	Verify	When used
Power Meter	HP	E4418B	i00228	9/17/2010	9/17/2011
Signal Generator	R&S	SMT-03	i00266	Verify	When used
Bi-Log Antenna	Schaffner	CBL611C	i00267	11/21/2009	11/21/2011
Temperature Chamber	Tenney	Tenney II	i00287	Verify	When used
Voltmeter	Fluke	75III	i00320	2/16/2010	2/16/2011
Spectrum Analyzer	Agilent	E4407B	i00331	12/20/2010	12/20/2011
Power sensor	HP	8485A	i00344	9/15/2010	9/15/2011
Data Logger	Fluke	HYDRA Data Bucket	i00343	11/18/2010	11/18/2011
Spectrum analyzer	Textronix	RSA3308A	i00345	9/21/2010	9/21/2011
Humidity / Temp Meter	Control Co.	4189CC	i00335	3/27/2009	3/27/2011

In addition to the above listed equipment standard RF connectors and cables were utilized in the testing of the described equipment. Prior to testing these components were tested to verify proper operation.

END OF TEST REPORT