



Compliance Testing, LLC

Previously Flom Test Lab

EMI, EMC, RF Testing Experts Since 1963

toll-free: (866) 311-3268

fax: (480) 926-3598

<http://www.ComplianceTesting.com>

info@ComplianceTesting.com

Test Report

Prepared for: Kenwood USA Corporation

Model: TK-3312-1

Description: UHF Transceiver

FCC ID: ALH413800

To

FCC Part 22, 74, 90

Date of Issue: March 28, 2014

On the behalf of the applicant:

Kenwood USA Corporation
Communications Division
3970 Johns Creek Court
Suwanee, GA 30024

Attention of:

Joel Berger, Research & Development
Ph: (678) 474-4722
E-Mail: jberger@kenwoodusa.com

Prepared By
Compliance Testing, LLC
1724 S. Nevada Way
Mesa, AZ 85204
(480) 926-3100 phone / (480) 926-3598 fax
www.compliancetesting.com
Project No: p1420013

Alex Macon
Project Test Engineer

This report may not be reproduced, except in full, without written permission from Compliance Testing
All results contained herein relate only to the sample tested



Test Report Revision History

Revision	Date	Revised By	Reason for Revision
1.0	February 14, 2014	Alex Macon	Original Document
2.0	March 26, 2014	Alex Macon	Added Test Summary details
3.0	March 28, 2014	Alex Macon	Added missing rule parts to cover page



Table of Contents

<u>Description</u>	<u>Page</u>
Standard Test Conditions and Engineering Practices	6
Test Result Summary	7
Field Strength of Spurious Radiation	8
Test Equipment Utilized	11



ILAC / A2LA

Compliance Testing, LLC, has been accredited in accordance with the recognized International Standard ISO/IEC 17025:2005. This accreditation demonstrates technical competence for a defined scope and the operation of a laboratory quality management system (refer joint ISO-ILAC-IAF Communiqué dated January 2009).

The tests results contained within this test report all fall within our scope of accreditation, unless noted below.

Please refer to <http://www.compliancetesting.com/labscope.html> for current scope of accreditation.

Testing Certificate Number: **2152.01**



FCC Site Reg, #349717

IC Site Reg. #2044A-2

Non-accredited tests contained in this report:

N/A



The Applicant has been cautioned as to the following:

15.21: Information to the User

The user's manual or instruction manual for an intentional radiator shall caution the user that changes or modifications not expressly approved by the party responsible for compliance could void the user's authority to operate the equipment.

15.27(a): Special Accessories

Equipment marketed to a consumer must be capable of complying with the necessary regulations in the configuration in which the equipment is marketed. Where special accessories, such as shielded cables and/or special connectors are required to enable an unintentional or intentional radiator to comply with the emission limits in this part, the equipment must be marketed with, i.e. shipped and sold with, those special accessories. However, in lieu of shipping or packaging the special accessories with the unintentional or intentional radiator, the responsible party may employ other methods of ensuring that the special accessories are provided to the consumer, without an additional charge.

Information detailing any alternative method used to supply the special accessories for a grant of equipment authorization or retained in the verification records, as appropriate. The party responsible for the equipment, as detailed in § 2.909 of this chapter, shall ensure that these special accessories are provided with the equipment. The instruction manual for such devices shall include appropriate instructions on the first page of text concerned with the installation of the device that these special accessories must be used with the device. It is the responsibility of the user to use the needed special accessories supplied with the equipment.



Test and Measurement Data

All tests and measurement data shown were performed in accordance with FCC Rules and Regulations, Volume II, Part 2, Subpart J, Sections 2.947, 2.1033(c), 2.1041, 2.1046, 2.1047, 2.1049, 2.1051, 2.1053, 2.1055, 2.1057, and the rule parts listed on the cover page.

Standard Test Conditions and Engineering Practices

Except as noted herein, the following conditions and procedures were observed during the testing.

In accordance with ANSI/TIA 603C, and unless otherwise indicated in the specific measurement results, the ambient temperature of the actual EUT was maintained within the range of 10° to 40°C (50° to 104°F) unless the particular equipment requirements specify testing over a different temperature range. Also, unless otherwise indicated, the humidity levels were in the range of 10% to 90% relative humidity.

Environmental Conditions		
Temp (°C)	Humidity (%)	Pressure (mbar)
20.5 – 21.3	33.9 – 34.7	971.4 – 973.2

Measurement results, unless otherwise noted, are worst-case measurements.

EUT Description

Model: TK-3312-1

Description: UHF Digital Transceiver

Additional Information: EUT is a push to talk occupational radio.

EUT Operation during Tests

EUT was continuously keyed during testing.

Accessories: None

Cables: None

Modifications: None



Test Result Summary

Specification	Test Name	Pass, Fail, N/A	Comments
2.1046	Carrier Output Power (Conducted)	N/A	See Note 1
2.1051	Unwanted Emissions (Transmitter Conducted)	N/A	See Note 1
2.1053	Field Strength of Spurious Radiation	Pass	See Note 2
90.210, 2.1049	Emission Masks (Occupied Bandwidth)	N/A	See Note 1
2.1047	Audio Low Pass Filter (Voice Input)	N/A	See Note 1
2.1047	Audio Frequency Response	N/A	See Note 1
2.1047(a)	Modulation Limiting	N/A	See Note 1
90.213	Frequency Stability (Temperature Variation)	N/A	See Note 1
90.213	Frequency Stability (Voltage Variation)	N/A	See Note 1
90.214	Transient Frequency Behavior	N/A	See Note 1
RSS-Gen	Receiver Spurious Emissions	N/A	See Note 1
2.202	Necessary Bandwidth Calculation	N/A	See Note 1

Note 1: Report is intended for a Class 2 Permissive Change which is adding a new battery and new antennas. This test is not applicable as the accessory change would not alter these measurements.

Note 2: Testing performed with all additional antennas (KRA-42M, KRA-42M2, KRA-42M3) within their respective frequency ranges.



Field Strength of Spurious Radiation

Name of Test: Field Strength of Spurious Radiation **Engineer:** Alex Macon
Test Equipment Utilized: i00103, i00124, i00349, i00379, i00428 **Test Date:** 2/13/14

Test Procedure

- A) Connect the equipment as illustrated below.
- B) Adjust the spectrum analyzer to the following settings:
 - 1) Resolution Bandwidth 100 kHz (< 1 GHz), 1 MHz (> 1GHz)
 - 2) Video Bandwidth ≥ 3 times Resolution Bandwidth, or 30 kHz
 - 3) Sweep Speed ≤ 2000 Hz/second
 - 4) Detector Mode = Mean or Average Power
- C) Place the transmitter to be tested on the turntable in the standard test site. The transmitter is transmitting into a non-radiating load that is placed on the turntable. The RF cable to this load should be of minimum length.
- D) For each spurious measurement the test antenna should be adjusted to the correct length for the frequency involved. This length may be determined from a calibration ruler supplied with the equipment. Measurements shall be made from the lowest radio frequency generated in the equipment to the tenth harmonic of the carrier, except for the region close to the carrier equal to \pm the test bandwidth (see Section 1.3.4.4).
- E) For each spurious frequency, raise and lower the test antenna from 1 m to 4 m to obtain a maximum reading on the spectrum analyzer with the test antenna at horizontal polarity. Repeat this procedure to obtain the highest possible reading. Record this maximum reading.
- F) Repeat Step E) for each spurious frequency with the test antenna polarized vertically.
- G) Reconnect the equipment as illustrated.
- H) Keep the spectrum analyzer adjusted as in Step B).
- I) Remove the transmitter and replace it with a substitution antenna (the antenna should be half wavelength for each frequency involved). The center of the substitution antenna should be approximately at the same location as the center of the transmitter. At lower frequencies, where the substitution antenna is very long, this will be impossible to achieve when the antenna is polarized vertically. In such case the lower end of the antenna should be 0.3 m above the ground.
- J) Feed the substitution antenna at the transmitter end with a signal generator connected to the antenna by means of a non-radiating cable. With the antennas at both ends horizontally polarized and with the signal generator tuned to a particular spurious frequency, raise and lower the test antenna to obtain a maximum reading at the spectrum analyzer. Adjust the level of the signal generator output until the previously recorded maximum reading for this set of conditions is obtained. This should be done carefully repeating the adjustment of the test antenna and generator output.
- K) Repeat Step J) with both antennas vertically polarized for each spurious frequency.
- L) Calculate power in dBm into a reference ideal half-wave dipole antenna by reducing the readings obtained in Steps J) and K) by the power loss in the cable between the generator and the antenna and further corrected for the gain of the substitution antenna used relative to an ideal half-wave dipole antenna.
- M) The levels recorded in Step L) are absolute levels of radiated spurious emissions in dBm. The radiated spurious emissions in dB can be calculated by the following:

$$\text{Radiated spurious emissions dB} = 10\log_{10} (\text{TX power in watts}/0.001) - \text{the levels in Step I)}$$

NOTE: It is permissible that the other antennas provided can be referenced to a dipole.



Test Setup

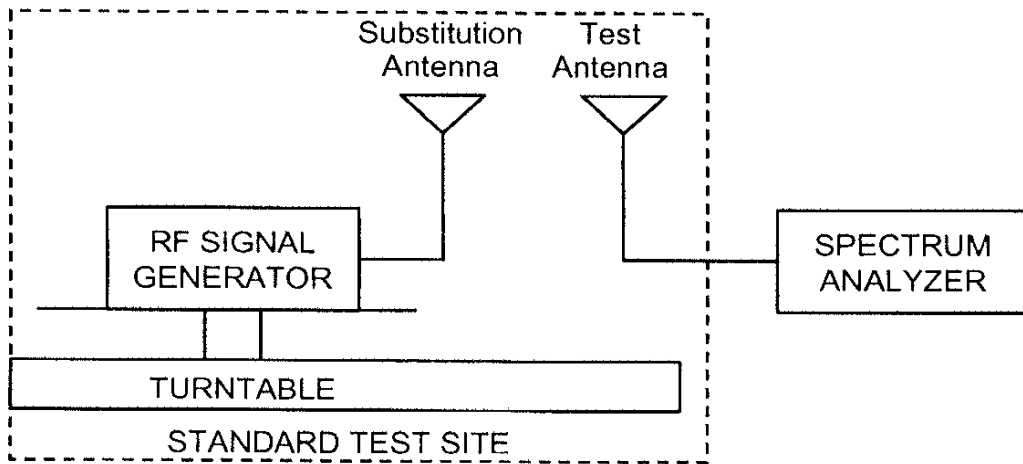
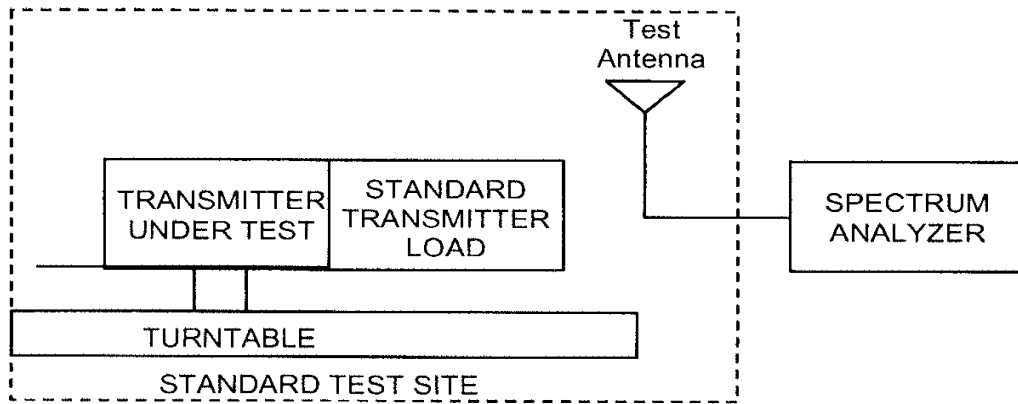



Test Results

Tuned Frequency (MHz)	Emission Frequency (MHz)	Measured Value (dBm)	Limit ERP/EIRP (dBm)	Result
450.05	900.1	-48.08	-25	Pass
	1350.1	-44.67	-25	Pass
	1800.2	-44.23	-25	Pass

Tuned Frequency (MHz)	Emission Frequency (MHz)	Measured Value (dBm)	Limit ERP/EIRP (dBm)	Result
480.05	960.0	-40.42	-25	Pass
	1440.1	-44.51	-25	Pass
	1920.1	-47.46	-25	Pass

Tuned Frequency (MHz)	Emission Frequency (MHz)	Measured Value (dBm)	Limit ERP/EIRP (dBm)	Result
511.95	1023.9	-36.03	-25	Pass
	1536.1	-41.87	-25	Pass
	2048.1	-51.93	-25	Pass

*The limit was set for -25 dBm for comparison to RSS-119 which is the more stringent limit. No other emissions were detected. All emissions were less than -25 dBm.



Test Equipment Utilized

Description	Manufacturer	Model Number	CT Asset Number	Last Cal Date	Cal Due Date
Horn Antenna	EMCO	3115	i00103	12/11/12	12/11/14
Tunable Notch Filter	Eagle	TNF-1-(250-850MHz)	i00124	NCR	NCR
Bi-Log Antenna	Schaffner	CBL 6111D	i00349	10/8/13	10/8/15
EMI Analyzer	Agilent	E7405A	i00379	1/14/14	1/14/15
Thermo Hygrometer	Omega	RH81	i00408	4/15/13	4/15/15
3 Meter Semi-Anechoic Chamber	Panashield	3 Meter Semi-Anechoic Chamber	i00428	11/14/13	11/14/15

In addition to the above listed equipment standard RF connectors and cables were utilized in the testing of the described equipment. Prior to testing these components were tested to verify proper operation.

END OF TEST REPORT



Test Setup Photos
FCC ID: ALH413800

RF Radiated #1

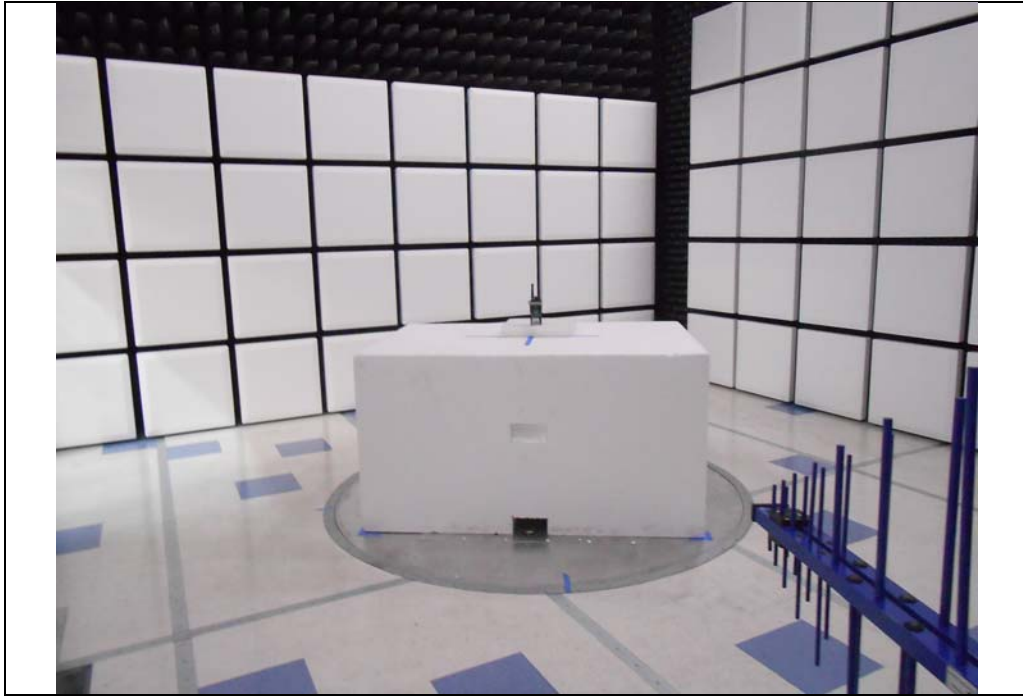

RF Radiated #2

