

	<u>Date(s) of Evaluation</u> June 13, 2007	<u>Test Report Serial No.</u> 061207ALH-T836-S90U	<u>Report Revision No.</u> Revision 1.0	
	<u>Test Report Issue Date</u> June 20, 2007	<u>Description of Test(s)</u> Specific Absorption Rate	<u>RF Exposure Category</u> Occupational (Controlled)	

APPENDIX E - SYSTEM VALIDATION

Company:	Kenwood USA Corporation	Model(s):	TK-3230-K	FCC ID:	ALH383200	KENWOOD
DUT Type:	Portable FM UHF PTT Radio Transceiver	Transmit Frequency Range:		460 - 470 MHz		
2007 Celltech Labs Inc.	This document is not to be reproduced in whole or in part without the prior written permission of Celltech Labs Inc.					Page 42 of 43

	Date of Evaluation:	June 07, 2007	Document Serial No.:	SV450B-060707-R1.0	
	Evaluation Type:	System Validation	Validation Dipole:	450 MHz	Fluid Type:

450 MHz SYSTEM VALIDATION

Type:

450 MHz Validation Dipole

Asset Number:

00024

Serial Number:

136

Place of Validation:

Celltech Labs Inc.

Date of Validation:

June 07, 2007

Celltech Labs Inc. certifies that the 450 MHz System Validation was performed on the date indicated above.

Validated by:

Cheri Frangiadakis

Approved by:

Jon Hughes

2. Validation Dipole VSWR Data

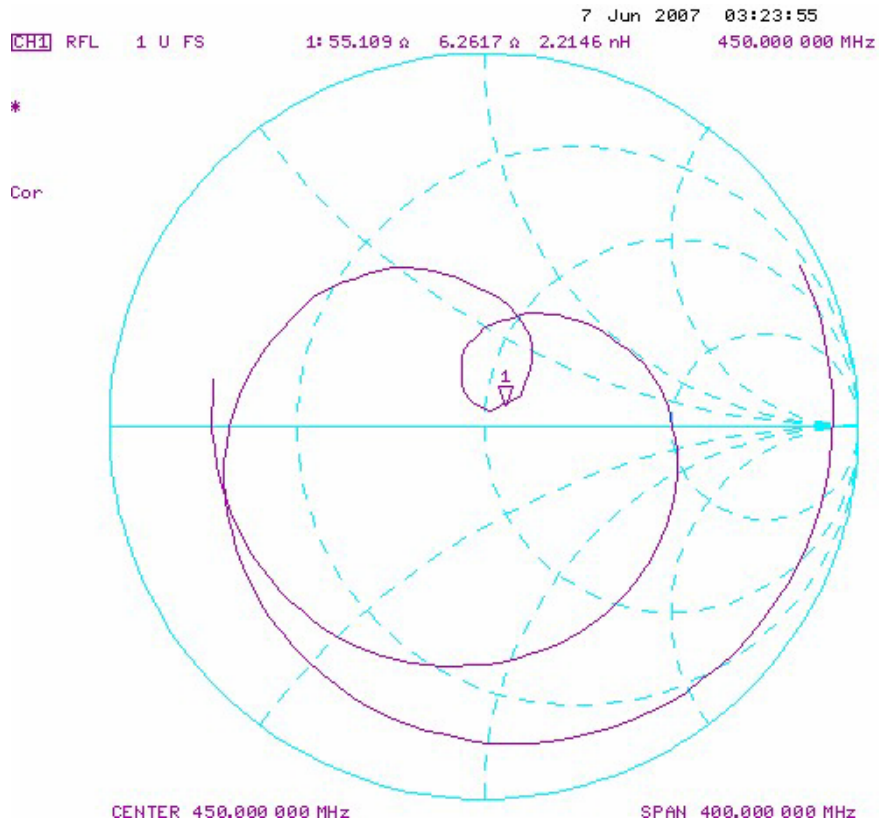
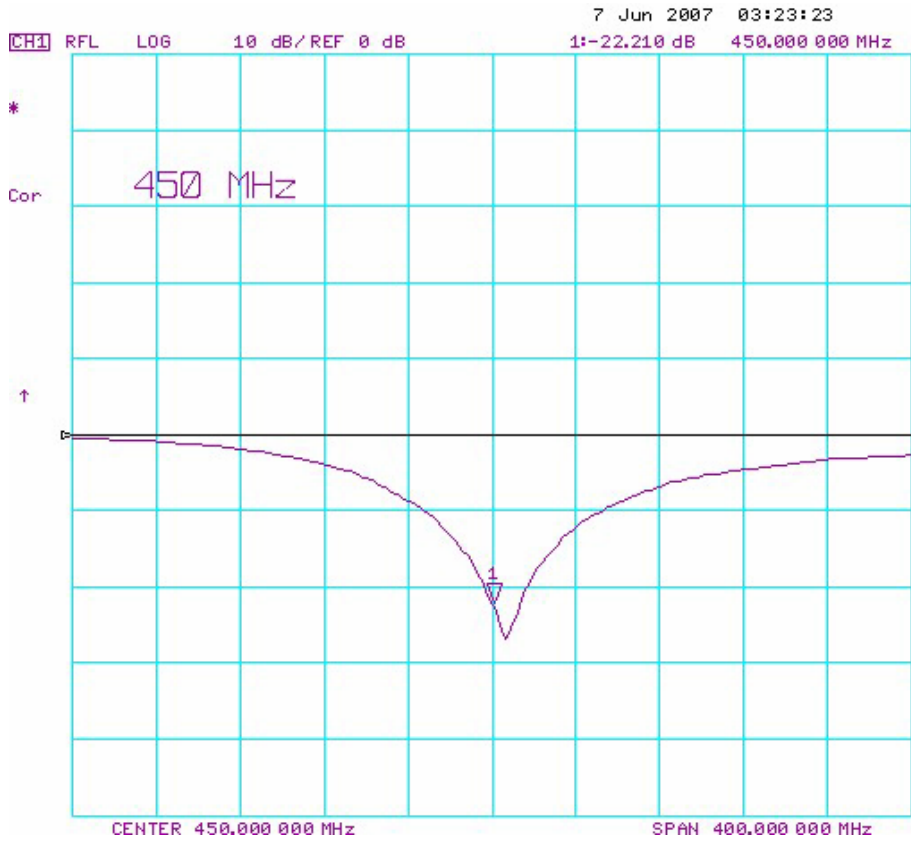

3. Validation Dipole Dimensions

Frequency (MHz)	L (mm)	h (mm)	d (mm)
300	396.0	250.0	6.0
450	270.0	167.0	6.0
835	161.0	89.8	3.6
900	149.0	83.3	3.6
1450	89.1	51.7	3.6
1800	72.0	41.7	3.6
1900	68.0	39.5	3.6
2000	64.5	37.5	3.6
2450	51.5	30.4	3.6
3000	41.5	25.0	3.6

4. Validation Phantom

The validation phantom (planar) was constructed using relatively low-loss tangent Plexiglas material.

The inner dimensions of the validation phantom are as follows:

Length: 83.5 cm
Width: 36.9 cm
Height: 21.8 cm

The bottom section of the validation phantom is constructed of 6.2 ± 0.1 mm Plexiglas.

5. Test Equipment List

TEST EQUIPMENT	ASSET NO.	SERIAL NO.	DATE OF CAL.	CAL. DUE DATE
SPEAG DASY4 Measurement Server	00158	1078	N/A	N/A
SPEAG Robot	00046	599396-01	N/A	N/A
SPEAG DAE4	00019	353	21Jun06	21Jun07
SPEAG ET3DV6 E-Field Probe	00016	1387	16Mar07	16Mar08
450 MHz Validation Dipole	00024	136	07Jun07	07Jun08
Plexiglas Validation Planar Phantom	00157	137	N/A	N/A
ALS-PR-DIEL Dielectric Probe Kit	00160	260-00953	N/A	N/A
Gigatronics 8652A Power Meter	00007	1835272	26Mar07	26Mar08
Gigatronics 80701A Power Sensor	00014	1833699	22Jan07	22Jan08
Gigatronics 80701A Power Sensor	00109	1834366	26Mar07	26Mar08
HP 8753ET Network Analyzer	00134	US39170292	20Apr07	20Apr08
HP 8648D Signal Generator	00005	3847A00611	NCR	NCR
Amplifier Research 5S1G4 Power Amplifier	00106	26235	NCR	NCR

6. Dimensions of Plexiglas Planar Phantom

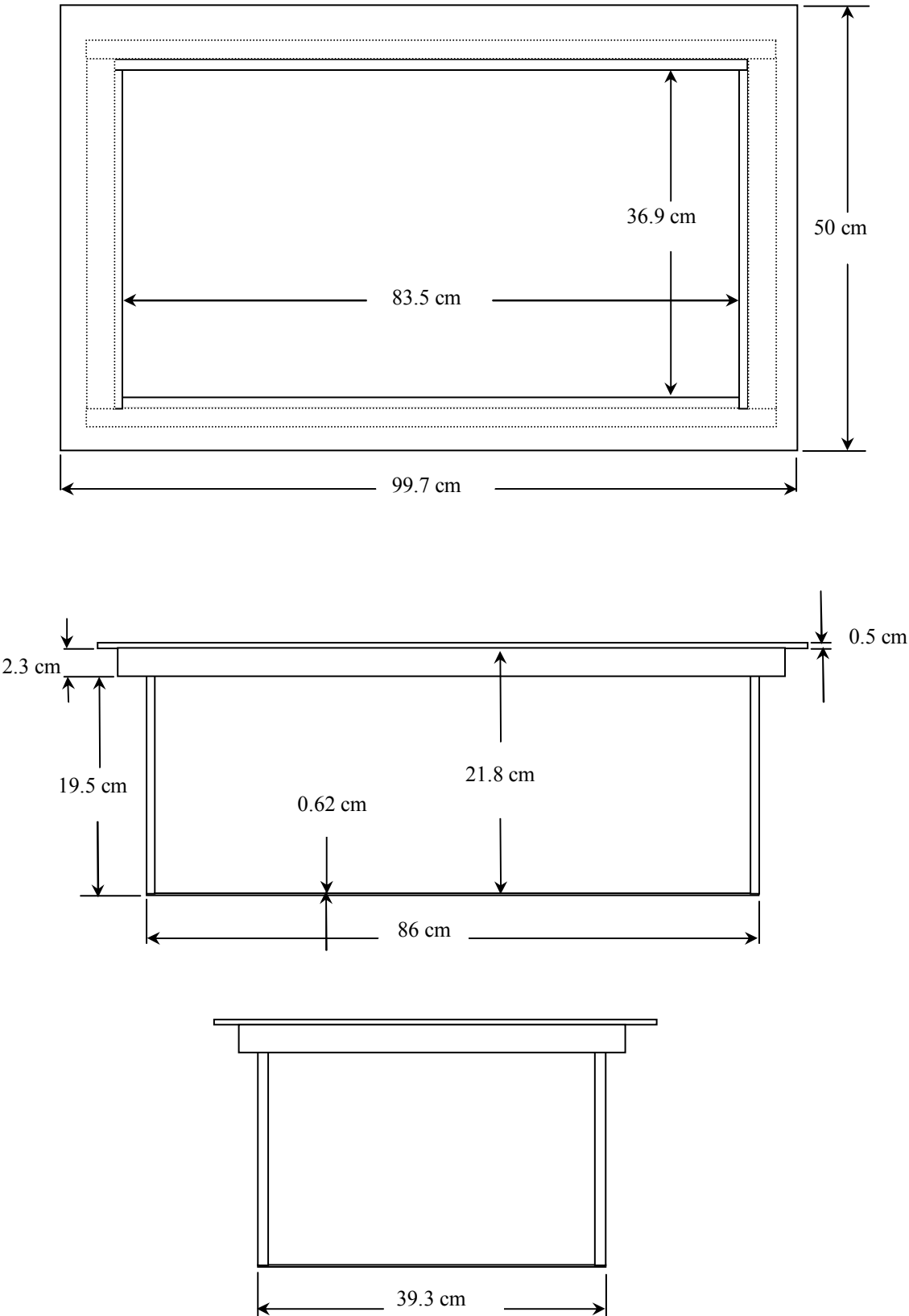

	Date of Evaluation:	June 07, 2007	Document Serial No.:	SV450B-060707-R1.0	
	Evaluation Type:	System Validation	Validation Dipole:	450 MHz	Fluid Type:

7. 450 MHz System Validation Setup



8. 450 MHz Dipole Setup



9. SAR Measurement

Measurements were made using a dosimetric E-field probe ET3DV6 (S/N: 1387, Conversion Factor 7.0). The SAR measurement was performed with the E-field probe in mechanical detection mode only. The setup and determination of the forward power into the dipole was performed using the procedures described below.

First the power meter PM1 (including attenuator Att1) is connected to the cable to measure the forward power at the location of the dipole connector (X). The signal generator is adjusted for the desired forward power at the dipole connector (taking into account the attenuation of Att1) as read by power meter PM2. After connecting the cable to the dipole, the signal generator is readjusted for the same reading at power meter PM2. If the signal generator does not allow adjustment in 0.01dB steps, the remaining difference at PM2 must be taken into consideration. PM3 records the reflected power from the dipole to ensure that the value is not changed from the previous value. The reflected power should be 20dB below the forward power.

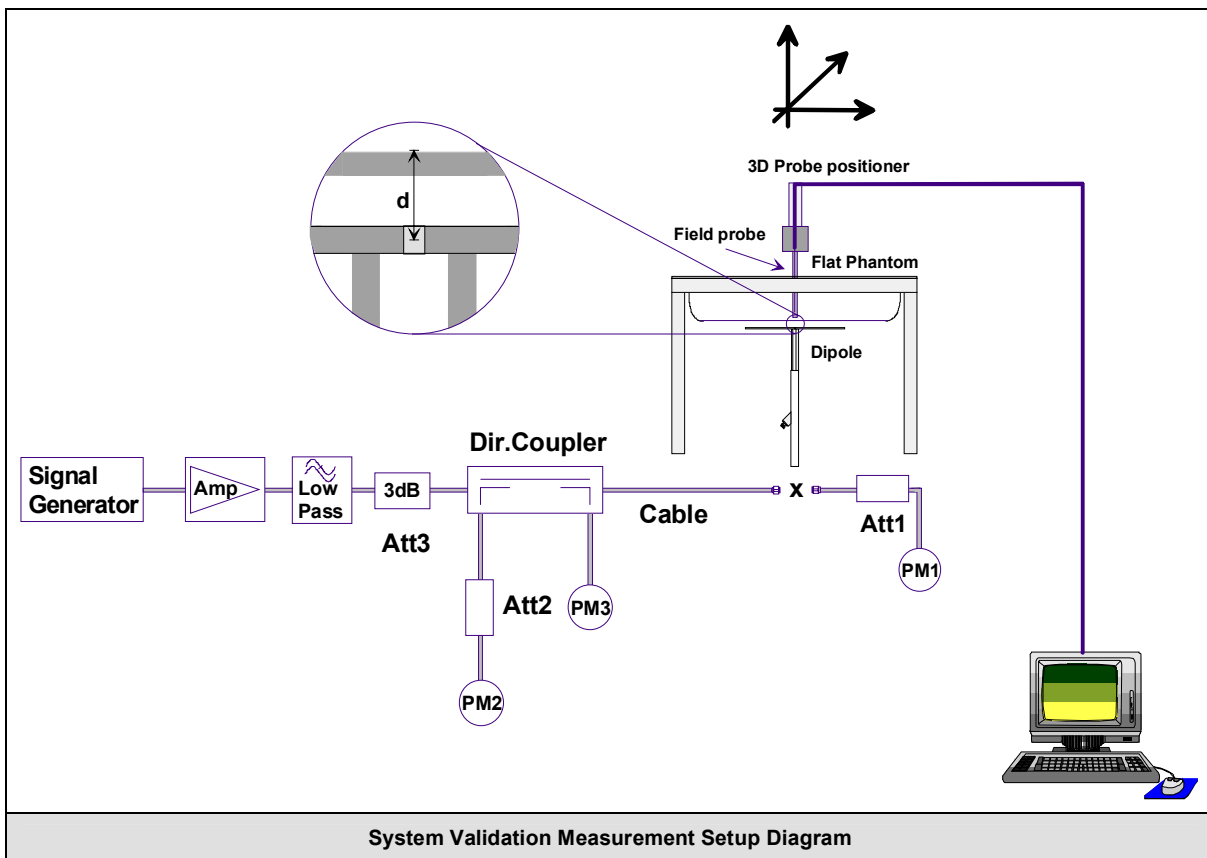

10. Measurement Conditions

The validation phantom was filled with 450 MHz Brain tissue simulant.

Relative Permittivity: 44.9 (+3.3% deviation from target)
 Conductivity: 0.91 mho/m (+4.6% deviation from target)
 Fluid Temperature: 21.4°C (Start of Test) / 21.4 °C (End of Test)
 Fluid Depth: ≥ 15.0 cm

Environmental Conditions:

Ambient Temperature: 24.7°C
 Barometric Pressure: 96.8 kPa
 Humidity: 31%

The 450 MHz Brain tissue simulant consisted of the following ingredients:

Ingredient	Percentage by weight	
Water	38.56%	
Sugar	56.32%	
Salt	3.95%	
HEC	0.98%	
Dowicil 75	0.19%	
Target Dielectric Parameters:	$\epsilon_r = 43.5 (+/- 5\%)$	$\sigma = 0.87 \text{ S/m } (+/- 5\%)$

11. System Validation SAR Results

SAR @ 0.25W Input averaged over 1g (W/kg)				SAR @ 1W Input averaged over 1g (W/kg)			
IEEE/IEC Target	Measured	Deviation		IEEE/IEC Target	Measured	Deviation	
1.23	+/- 10%	1.19	-3.2%	4.9	+/- 10%	4.76	-2.8%
SAR @ 0.25W Input averaged over 10g (W/kg)				SAR @ 1W Input averaged over 10g (W/kg)			
IEEE/IEC Target	Measured	Deviation		IEEE/IEC Target	Measured	Deviation	
0.825	+/- 10%	0.769	-6.8%	3.3	+/- 10%	3.08	-6.6%
Frequency (MHz)	1 g SAR	10 g SAR	Local SAR at surface (above feed-point)	Local SAR at surface (y = 2 cm offset from feed-point) ²			
300	3.0	2.0	4.4	2.1			
450	4.9	3.3	7.2	3.2			
835	9.5	6.2	4.1	4.9			
900	10.8	6.9	16.4	5.4			
1450	29.0	16.0	50.2	6.5			
1800	38.1	19.8	69.5	6.8			
1900	39.7	20.5	72.1	6.6			
2000	41.1	21.1	74.6	6.5			
2450	52.4	24.0	104.2	7.7			
3000	63.8	25.7	140.2	9.5			
Numerical reference SAR values for reference dipole and flat phantom normalized to 1 W (IEEE 1528-2003; IEC 62209-1:2005)							

	Date of Evaluation:	June 07, 2007	Document Serial No.:	SV450B-060707-R1.0
	Evaluation Type:	System Validation	Validation Dipole:	450 MHz
			Fluid Type:	Brain

System Validation - 450 MHz Dipole - June 7, 2007

DUT: Dipole 450 MHz; Asset: 00024; Serial: 136

Ambient Temp: 24.7°C; Fluid Temp: 21.4°C; Barometric Pressure: 96.8 kPa; Humidity: 31%

Communication System: CW

Forward Conducted Power: 250 mW

Frequency: 450 MHz; Duty Cycle: 1:1

Medium: HSL450 Medium parameters used: $f = 450 \text{ MHz}$; $\sigma = 0.91 \text{ mho/m}$; $\epsilon_r = 44.9$; $\rho = 1000 \text{ kg/m}^3$

- Probe: ET3DV6 - SN1387; ConvF(7, 7, 7); Calibrated: 16/03/2007
- Sensor-Surface: 4mm (Mechanical Surface Detection)
- Electronics: DAE4 Sn353; Calibrated: 21/06/2006
- Phantom: Validation Planar; Type: Plexiglas; Serial: 137
- Measurement SW: DASY4, V4.7 Build 44; Postprocessing SW: SEMCAD, V1.8 Build 171

450 MHz System Validation/Area Scan (6x11x1):

Measurement grid: $dx=15\text{mm}$, $dy=15\text{mm}$

Maximum value of SAR (measured) = 1.19 mW/g

450 MHz System Validation/Zoom Scan (5x5x7)/Cube 0:

Measurement grid: $dx=7.5\text{mm}$, $dy=7.5\text{mm}$, $dz=5\text{mm}$

Reference Value = 37.1 V/m; Power Drift = -0.001 dB

Peak SAR (extrapolated) = 2.08 W/kg

SAR(1 g) = 1.19 mW/g; SAR(10 g) = 0.769 mW/g

Maximum value of SAR (measured) = 1.25 mW/g

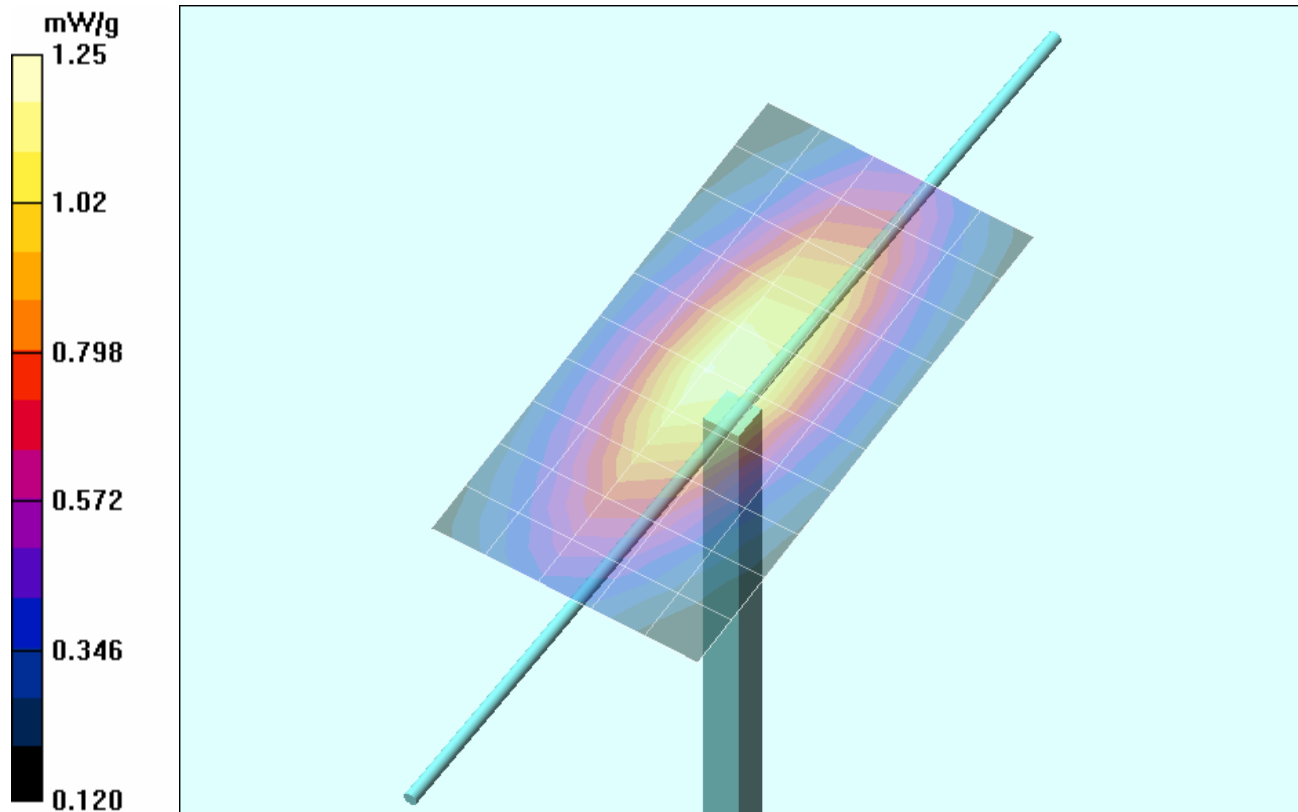

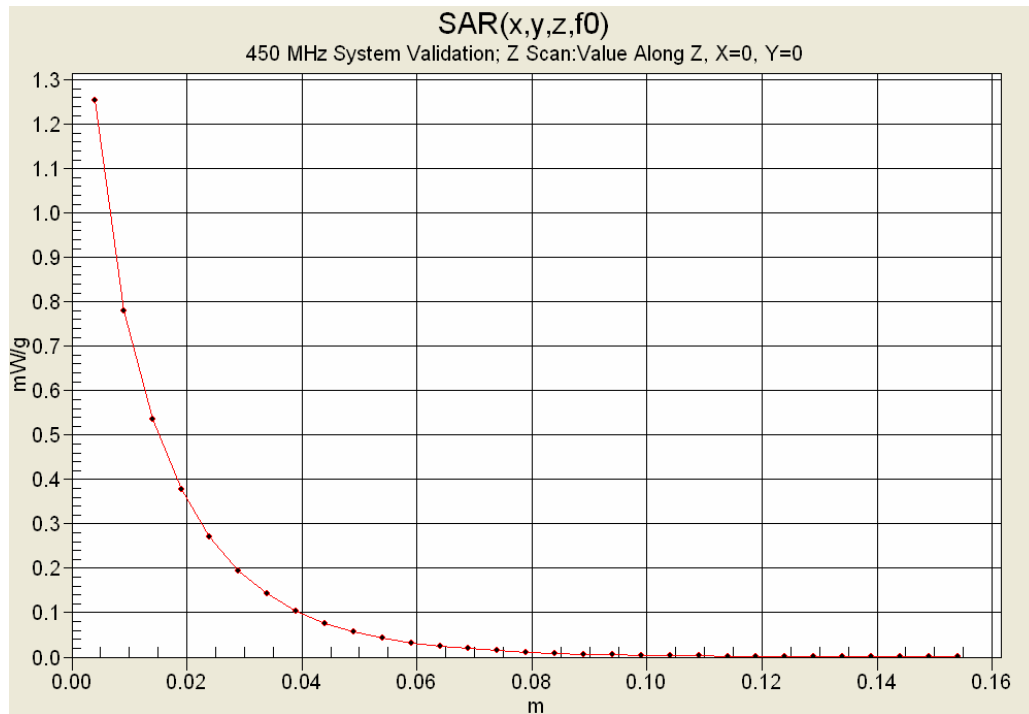

12. Measured Fluid Dielectric Parameters

System Validation - 450 MHz (Brain)

Celltech Labs Inc.

Test Result for UIM Dielectric Parameter

Thu 07/Jun/2007

Frequency (GHz)

FCC_eH FCC OET 65 Supplement C (June 2001) Limits for Head Epsilon

FCC_sH FCC OET 65 Supplement C (June 2001) Limits for Head Sigma

Test_e Epsilon of UIM

Test_s Sigma of UIM

Freq	FCC_eH	FCC_sH	Test_e	Test_s
0.3500	44.70	0.87	47.03	0.83
0.3600	44.58	0.87	46.92	0.83
0.3700	44.46	0.87	46.66	0.84
0.3800	44.34	0.87	46.46	0.86
0.3900	44.22	0.87	45.98	0.86
0.4000	44.10	0.87	45.91	0.87
0.4100	43.98	0.87	45.71	0.88
0.4200	43.86	0.87	45.34	0.89
0.4300	43.74	0.87	45.22	0.90
0.4400	43.62	0.87	44.94	0.90
0.4500	43.50	0.87	44.88	0.91
0.4600	43.45	0.87	44.70	0.92
0.4700	43.40	0.87	44.48	0.93
0.4800	43.34	0.87	44.11	0.94
0.4900	43.29	0.87	43.91	0.95
0.5000	43.24	0.87	43.83	0.95
0.5100	43.19	0.87	43.55	0.96
0.5200	43.14	0.88	43.34	0.97
0.5300	43.08	0.88	42.97	0.98
0.5400	43.03	0.88	42.96	0.98
0.5500	42.98	0.88	43.02	1.00

13. Measurement Uncertainties

UNCERTAINTY BUDGET FOR SYSTEM VALIDATION						
Error Description	Uncertainty Value ±%	Probability Distribution	Divisor	ci 1g	Uncertainty Value ±% (1g)	V _i or V _{eff}
Measurement System						
Probe calibration (450 MHz)	8.0	Normal	1	1.0	8.0	∞
Axial isotropy of the probe	4.7	Rectangular	1.732050808	0.7	1.9	∞
Spherical isotropy of the probe	9.6	Rectangular	1.732050808	0.7	3.9	∞
Spatial resolution	0.0	Rectangular	1.732050808	1	0.0	∞
Boundary effects	1.0	Rectangular	1.732050808	1	0.6	∞
Probe linearity	4.7	Rectangular	1.732050808	1	2.7	∞
Detection limit	1.0	Rectangular	1.732050808	1	0.6	∞
Readout electronics	0.3	Normal	1	1	0.3	∞
Response time	0.8	Rectangular	1.732050808	1	0.5	∞
Integration time	2.6	Rectangular	1.732050808	1	1.5	∞
RF ambient conditions	3.0	Rectangular	1.732050808	1	1.7	∞
Mech. constraints of robot	0.4	Rectangular	1.732050808	1	0.2	∞
Probe positioning	2.9	Rectangular	1.732050808	1	1.7	∞
Extrapolation & integration	1.0	Rectangular	1.732050808	1	0.6	∞
Test Sample Related						
Device positioning	2.0	Normal	1.732050808	1	1.2	∞
Power drift	5.0	Rectangular	1.732050808	1	2.9	∞
Phantom and Setup						
Phantom uncertainty	4.0	Rectangular	1.732050808	1	2.3	∞
Liquid conductivity (target)	5.0	Rectangular	1.732050808	0.7	2.0	∞
Liquid conductivity (measured)	5.0	Rectangular	1.732050808	0.7	2.0	∞
Liquid permittivity (target)	5.0	Rectangular	1.732050808	0.6	1.7	∞
Liquid permittivity (measured)	5.0	Rectangular	1.732050808	0.6	1.7	∞
Combined Standard Uncertainty					11.34	
Expanded Uncertainty (k=2)					22.68	
Note(s)	1. Measurement Uncertainty Table in accordance with IEC 62209-1:2005.					

UNCERTAINTY BUDGET FOR SYSTEM VALIDATION						
Error Description	Uncertainty Value $\pm\%$	Probability Distribution	Divisor	c_i 1g	Uncertainty Value $\pm\%$ (1g)	V_i or V_{eff}
Measurement System						
Probe calibration (450 MHz)	8.0	Normal	1	1.0	8.0	∞
Axial isotropy of the probe	4.7	Rectangular	1.732050808	0.7	1.9	∞
Spherical isotropy of the probe	0.0	Rectangular	1.732050808	0.7	3.9	∞
Spatial resolution	0.0	Rectangular	1.732050808	1	0.0	∞
Boundary effects	1.0	Rectangular	1.732050808	1	0.6	∞
Probe linearity	4.7	Rectangular	1.732050808	1	2.7	∞
Detection limit	1.0	Rectangular	1.732050808	1	0.6	∞
Readout electronics	0.3	Normal	1	1	0.3	∞
Response time	0.0	Rectangular	1.732050808	1	0.5	∞
Integration time	0.0	Rectangular	1.732050808	1	1.5	∞
RF ambient conditions	3.0	Rectangular	1.732050808	1	1.7	∞
Mech. constraints of robot	0.4	Rectangular	1.732050808	1	0.2	∞
Probe positioning	2.9	Rectangular	1.732050808	1	1.7	∞
Extrapolation & integration	1.0	Rectangular	1.732050808	1	0.6	∞
Test Sample Related						
Device positioning	2.0	Normal	1.732050808	1	1.2	∞
Power drift	4.7	Rectangular	1.732050808	1	2.9	∞
Phantom and Setup						
Phantom uncertainty	4.0	Rectangular	1.732050808	1	2.3	∞
Liquid conductivity (target)	5.0	Rectangular	1.732050808	0.7	2.0	∞
Liquid conductivity (measured)	5.0	Rectangular	1.732050808	0.7	2.0	∞
Liquid permittivity (target)	5.0	Rectangular	1.732050808	0.6	1.7	∞
Liquid permittivity (measured)	5.0	Rectangular	1.732050808	0.6	1.7	∞
Combined Standard Uncertainty					11.20	
Expanded Uncertainty (k=2)					22.39	
Note(s)	1. Measurement Uncertainty Table in accordance with IEEE 1528-2003.					