

DECLARATION OF COMPLIANCE SAR RF EXPOSURE EVALUATION

Test Lab

CELLTECH LABS INC.
Testing and Engineering Services
1955 Moss Court
Kelowna, B.C.
Canada V1Y 9L3
Phone: 250-448-7047
Fax: 250-448-7046
e-mail: info@celltechlabs.com
web site: www.celltechlabs.com

Applicant Information

KENWOOD USA CORPORATION
3975 John Creek Court, Suite 300
Suwanee, GA 30024

Rule Part(s):	FCC 47 CFR §2.1093; IC RSS-102 Issue 1 (Provisional)
Test Procedure(s):	FCC OET Bulletin 65, Supplement C (01-01)
Device Type:	Portable UHF PTT Radio Transceiver
FCC ID:	ALH36923210
Model(s):	TK-3202-1
Modulation:	FM (UHF)
Tx Frequency Range:	450.00 - 490.00 MHz
Max. RF Output Power Tested:	36.54 dBm Conducted (450 MHz) 36.30 dBm Conducted (470 MHz) 36.23 dBm Conducted (490 MHz)
Antenna Type(s):	1. Whip (P/N: KRA-27M) 2. Stubby (P/N: KRA-23M)
Battery Type(s):	NiMH 7.5V, 1500mAh (P/N: KNB-29N) NiCd 7.5V, 1100mAh (P/N: KNB-30A)
Body-Worn Accessories:	Belt-Clip, Speaker-Microphone
Max. SAR Measured:	Face-held: 4.14 W/kg (50% Duty Cycle) Body-worn: 5.33 W/kg (50% Duty Cycle)

Celltech Labs Inc. declares under its sole responsibility that this wireless portable device has demonstrated compliance with the Specific Absorption Rate (SAR) RF exposure requirements specified in FCC 47 CFR §2.1093 and Health Canada's Safety Code 6. The device was tested in accordance with the measurement standards and procedures specified in FCC OET Bulletin 65, Supplement C (Edition 01-01) and Industry Canada RSS-102 Issue 1 (Provisional) for the Occupational / Controlled Exposure environment. All measurements were performed in accordance with the SAR system manufacturer recommendations.

I attest to the accuracy of data. All measurements were performed by me or were made under my supervision and are correct to the best of my knowledge and belief. I assume full responsibility for the completeness of these measurements and vouch for the qualifications of all persons taking them.

This test report shall not be reproduced partially, or in full, without the prior written approval of Celltech Labs Inc. The results and statements contained in this report pertain only to the device(s) evaluated.



Russell W. Pipe
Senior Compliance Technologist
Celltech Labs Inc.



TABLE OF CONTENTS		
1.0	INTRODUCTION.....	3
2.0	DESCRIPTION OF DUT.....	3
3.0	SAR MEASUREMENT SYSTEM	4
4.0	MEASUREMENT SUMMARY.....	5-6
5.0	DETAILS OF SAR EVALUATION.....	7
6.0	EVALUATION PROCEDURES.....	7
7.0	SYSTEM PERFORMANCE CHECK.....	8
8.0	SIMULATED EQUIVALENT TISSUES.....	9
9.0	SAR SAFETY LIMITS.....	9
10.0	ROBOT SYSTEM SPECIFICATIONS.....	10
11.0	PROBE SPECIFICATION.....	11
12.0	PLANAR PHANTOM.....	11
13.0	VALIDATION PHANTOM.....	11
14.0	DEVICE HOLDER.....	11
15.0	TEST EQUIPMENT LIST.....	12
16.0	MEASUREMENT UNCERTAINTIES.....	13-14
17.0	REFERENCES.....	15
	APPENDIX A - SAR MEASUREMENT DATA.....	16
	APPENDIX B - SYSTEM PERFORMANCE CHECK DATA.....	17
	APPENDIX C - SYSTEM VALIDATION PROCEDURES.....	18
	APPENDIX D - PROBE CALIBRATION.....	19
	APPENDIX E - MEASURED FLUID DIELECTRIC PARAMETERS.....	20
	APPENDIX F - SAR TEST SETUP & DUT PHOTOGRAPHS.....	21

1.0 INTRODUCTION

This measurement report demonstrates compliance of the Kenwood USA Corporation Model: TK-3202-1 Portable UHF PTT Radio Transceiver FCC ID: ALH36923210 with the SAR (Specific Absorption Rate) RF exposure requirements specified in FCC 47 CFR §2.1093 (see reference [1]), and Health Canada's Safety Code 6 (see reference [2]) for the Occupational / Controlled Exposure environment. The measurement procedures described in FCC OET Bulletin 65, Supplement C (Edition 01-01) (see reference [3]) and IC RSS-102 Issue 1 (Provisional) (see reference [4]), were employed. A description of the product, operating configuration, detailed summary of the test results, methodology and procedures used in the evaluation, equipment used, and the various provisions of the rules are included within this test report.

2.0 DESCRIPTION OF DEVICE UNDER TEST (DUT)

FCC Rule Part(s)	47 CFR §2.1093		
IC Rule Part(s)	RSS-102 Issue 1 (Provisional)		
Test Procedure(s)	FCC OET Bulletin 65, Supplement C (Edition 01-01)		
Device Type	Portable UHF PTT Radio Transceiver		
FCC ID	ALH36923210		
Model(s)	TK-3202-1		
Serial No.	U12 (Identical Prototype)		
Modulation	FM (UHF)		
Tx Frequency Range	450.00 - 490.00 MHz		
Max. RF Output Power Tested	450 MHz	36.54 dBm	Conducted
	470 MHz	36.30 dBm	Conducted
	490 MHz	36.23 dBm	Conducted
Antenna Type(s) Tested	Whip	Length: 154 mm	P/N: KRA-27M
	Stubby	Length: 84 mm	P/N: KRA-23M
Battery Type(s) Tested	NiMH	7.5V, 1500mAh	P/N: KNB-29N
	NiCd	7.5V, 1100mAh	P/N: KNB-30A)
Body-Worn Accessories Tested	Belt-Clip		
	Speaker-Microphone		

3.0 SAR MEASUREMENT SYSTEM

Celltech Labs Inc. SAR measurement facility utilizes the Dosimetric Assessment System (DASY™) manufactured by Schmid & Partner Engineering AG (SPEAG™) of Zurich, Switzerland. The DASY4 measurement system is comprised of the measurement server, robot controller, computer, near-field probe, probe alignment sensor, specific anthropomorphic mannequin (SAM) phantom, and various planar phantoms for brain and/or body SAR evaluations. The robot is a six-axis industrial robot performing precise movements to position the probe to the location (points) of maximum electromagnetic field (EMF). A cell controller system contains the power supply, robot controller, teach pendant (Joystick), and remote control, is used to drive the robot motors. The Staubli robot is connected to the cell controller to allow software manipulation of the robot. A data acquisition electronic (DAE) circuit performs the signal amplification, signal multiplexing, AD-conversion, offset measurements, mechanical surface detection, collision detection, etc. is connected to the Electro-optical coupler (EOC). The EOC performs the conversion from the optical into digital electric signal of the DAE and transfers data to the DASY4 measurement server. The DAE4 utilizes a highly sensitive electrometer-grade preamplifier with auto-zeroing, a channel and gain-switching multiplexer, a fast 16-bit AD-converter and a command decoder and control logic unit. Transmission to the DASY4 measurement server is accomplished through an optical downlink for data and status information and an optical uplink for commands and clock lines. The mechanical probe-mounting device includes two different sensor systems for frontal and sidewise probe contacts. The sensor systems are also used for mechanical surface detection and probe collision detection. The robot uses its own controller with a built in VME-bus computer.



DASY4 SAR Measurement System with validation phantom



DASY4 SAR Measurement System with Plexiglas planar phantom

4.0 MEASUREMENT SUMMARY

FACE-HELD SAR EVALUATION RESULTS

Freq. (MHz)	Chan.	Test Mode	Measured Conducted RF Output Power			Battery Type	Antenna Type	Antenna Part. No.	Separation Distance to Planar Phantom (cm)	Measured SAR (W/kg)		Max. Cond. Power Drift (dB)	Scaled SAR (W/kg)	
			Before (dBm)	After (dBm)	Drift (dB)					Duty Cycle			Duty Cycle	
										100%	50%		100%	50%
470	Mid	CW	36.28	35.38	-0.90	NiCd	Stubby	KRA-23M	2.5	6.07	3.04	-0.95	7.55	3.78
470	Mid	CW	36.24	35.53	-0.71	NiMH	Stubby	KRA-23M	2.5	6.10	3.05	-0.95	7.59	3.80
470	Mid	CW	36.20	35.49	-0.71	NiCd	Whip	KRA-27M	2.5	6.76	3.38	-0.88	8.28	4.14
470	Mid	CW	36.24	35.54	-0.70	NiMH	Whip	KRA-27M	2.5	6.53	3.27	-0.88	8.00	4.00
450	Low	CW	36.42	35.94	-0.48	NiCd	Whip	KRA-27M	2.5	5.37	2.69	-0.88	6.58	3.29
490	High	CW	36.20	35.40	-0.80	NiCd	Whip	KRA-27M	2.5	5.45	2.73	-0.88	6.67	3.34

ANSI / IEEE C95.1 1992 - SAFETY LIMIT
Spatial Peak - Controlled Exposure / Occupational
BRAIN: 8.0 W/kg (averaged over 1 gram)

Test Date	12/17/03		Ambient Temperature	24.4 °C
Measured Fluid Type	450 MHz Brain		Fluid Temperature	21.4 °C
Dielectric Constant ϵ_r	IEEE Target	Measured	Fluid Depth	≥ 15 cm
	43.5 (± 5%)	42.9	Relative Humidity	33%
Conductivity σ (mho/m)	IEEE Target	Measured	Atmospheric Pressure	98.1 KPa
	0.87 (± 5%)	0.84	ρ (Kg/m ³)	1000

Note(s):

- The measurement results were obtained with the DUT tested in the conditions described in this report. Detailed measurement data and plots showing the maximum SAR location of the DUT are reported in Appendix A.
- The SAR evaluations were initially performed with both NiMH and NiCd batteries at the mid channel. The worst-case battery was subsequently tested at the low and high channels (if the SAR measurements performed at the mid channel were ≥ 3dB below the SAR limit, SAR evaluation for the low and high channels was optional per FCC OET Bulletin 65, Supplement C, Edition 01-01 (see reference [3])).
- The conducted power levels measured after the SAR evaluations were > 5% from the measured start power. The maximum conducted power drift measured for each antenna type was subsequently added to the corresponding measured SAR levels to show scaled SAR results as listed in the above table. The maximum conducted power drifts recorded in the table above were measured during the body-worn SAR evaluations.
- The ambient and fluid temperatures were measured prior to, and during, the fluid dielectric parameter check and the SAR evaluation. The temperatures listed were consistent for all measurement periods.
- The dielectric parameters of the simulated tissue mixture were measured prior to the evaluation using an 85070C Dielectric Probe Kit and an 8753E Network Analyzer (see Appendix E for printout of measured fluid dielectric parameters).

MEASUREMENT SUMMARY (Cont.)

BODY-WORN SAR EVALUATION RESULTS

Freq. (MHz)	Chan.	Test Mode	Measured Conducted RF Output Power			Battery Type	Antenna Type	Body-Worn Accessories	Separation Distance to Planar Phantom (cm)	Measured SAR (W/kg)		Max. Cond. Power Drift (dB)	Scaled SAR (W/kg)	
			Before (dBm)	After (dBm)	Drift (dB)					Duty Cycle			Duty Cycle	
										100%	50%		100%	50%
470	Mid	CW	36.26	35.31	-0.95	NiCd	Stubby	Speaker-Mic Belt-Clip	1.1	7.99	4.00	-0.95	9.94	4.97
470	Mid	CW	36.24	35.48	-0.76	NiMH	Stubby	Speaker-Mic Belt-Clip	1.1	7.85	3.93	-0.95	9.77	4.88
450	Low	CW	36.48	35.93	-0.55	NiCd	Stubby	Speaker-Mic Belt-Clip	1.1	6.42	3.21	-0.95	7.99	3.99
490	High	CW	36.19	35.52	-0.67	NiCd	Stubby	Speaker-Mic Belt-Clip	1.1	4.17	2.09	-0.95	5.19	2.59
470	Mid	CW	36.30	35.45	-0.85	NiCd	Whip	Speaker-Mic Belt-Clip	1.1	8.70	4.35	-0.88	10.65	5.33
470	Mid	CW	36.26	35.55	-0.71	NiMH	Whip	Speaker-Mic Belt-Clip	1.1	8.65	4.33	-0.88	10.59	5.30
450	Low	CW	36.54	35.95	-0.59	NiCd	Whip	Speaker-Mic Belt-Clip	1.1	6.80	3.40	-0.88	8.33	4.16
490	High	CW	36.23	35.35	-0.88	NiCd	Whip	Speaker-Mic Belt-Clip	1.1	7.30	3.65	-0.88	8.94	4.47

ANSI / IEEE C95.1 1992 - SAFETY LIMIT
Spatial Peak - Controlled Exposure / Occupational
BODY: 8.0 W/kg (averaged over 1 gram)

Test Date	12/18/03		Ambient Temperature	24.4 °C
Measured Fluid Type	450 MHz Body		Fluid Temperature	20.8 °C
Dielectric Constant ϵ_r	IEEE Target	Measured	Fluid Depth	≥ 15 cm
	56.7 (± 5%)	56.3	Relative Humidity	35%
Conductivity σ (mho/m)	IEEE Target	Measured	Atmospheric Pressure	98.2 kPa
	0.94 (± 5%)	0.91	ρ (Kg/m³)	1000

Note(s):

- The measurement results were obtained with the DUT tested in the conditions described in this report. Detailed measurement data and plots showing the maximum SAR location of the DUT are reported in Appendix A.
- The SAR evaluations were initially performed with both NiMH and NiCd batteries at the mid channel. The worst-case battery was subsequently tested at the low and high channels (if the SAR measurements performed at the mid channel were ≥ 3dB below the SAR limit, SAR evaluation for the low and high channels was optional per FCC OET Bulletin 65, Supplement C, Edition 01-01 (see reference [3])).
- The conducted power levels measured after the SAR evaluations were > 5% from the measured start power. The maximum conducted power drift measured for each antenna type was subsequently added to the corresponding measured SAR levels to show scaled SAR results as listed in the above table.
- The ambient and fluid temperatures were measured prior to, and during, the fluid dielectric parameter check and the SAR evaluation. The temperatures listed were consistent for all measurement periods.
- The dielectric parameters of the simulated tissue mixture were measured prior to the evaluation using an 85070C Dielectric Probe Kit and an 8753E Network Analyzer (see Appendix E for printout of measured fluid dielectric parameters).

5.0 DETAILS OF SAR EVALUATION

The Kenwood USA Corporation Model: TK-3202-1 Portable UHF PTT Radio Transceiver FCC ID: ALH36923210 was found to be compliant for localized Specific Absorption Rate (Occupational / Controlled Exposure) based on the test provisions and conditions described below. The detailed test setup photographs are shown in Appendix F.

1. The DUT was evaluated in a face-held configuration with the front of the radio placed parallel to the outer surface of the planar phantom. A 2.5 cm separation distance was maintained between the front side of the DUT and the outer surface of the planar phantom for the duration of the tests. The DUT was evaluated for face-held SAR with both whip and stubby type antennas.
2. The DUT was evaluated in a body-worn configuration with the back of the radio placed parallel to the outer surface of the planar phantom. The attached belt-clip was touching the planar phantom and provided a 1.1 cm separation distance between the back of the DUT and the outer surface of the planar phantom. The DUT was tested for body-worn SAR with the speaker-microphone accessory connected, and with both whip and stubby type antennas.
3. The conducted power levels were measured before and after each test according to the procedures described in FCC 47 CFR §2.1046. The conducted power levels measured after the SAR evaluations were > 5% from the measured start power. The maximum conducted power drift measured for each antenna type was subsequently added to the corresponding measured SAR levels to show scaled SAR results as shown in the test data table (page 5-6).
4. The DUT was tested in unmodulated continuous transmit operation (Continuous Wave mode at 100% duty cycle) with the transmit key constantly depressed. For a push-to-talk device the 50% duty cycle compensation reported assumes a transmit/receive cycle of equal time base.
5. The DUT was tested with fully charged NiMH and NiCd batteries.
6. The SAR evaluations were performed using a Plexiglas planar phantom.
7. A stack of low-density, low-loss dielectric foamed polystyrene was used in place of the device holder.

6.0 EVALUATION PROCEDURES

- a. (i) The evaluation was performed in the applicable area of the phantom depending on the type of device being tested. For devices held to the ear during normal operation, both the left and right ear positions were evaluated using the SAM phantom.
(ii) For body-worn and face-held devices a planar phantom was used.
- b. The SAR was determined by a pre-defined procedure within the DASY4 software. Upon completion of a reference and optical surface check, the exposed region of the phantom was scanned near the inner surface with a grid spacing of 15mm x 15mm.

An area scan was determined as follows:

- c. Based on the defined area scan grid, a more detailed grid is created to increase the points by a factor of 10. The interpolation function then evaluates all field values between corresponding measurement points.
- d. A linear search is applied to find all the candidate maxima. Subsequently, all maxima are removed that are >2 dB from the global maximum. The remaining maxima are then used to position the cube scans.

A 1g and 10g spatial peak SAR was determined as follows:

- e. Extrapolation is used to find the points between the dipole center of the probe and the surface of the phantom. This data cannot be measured, since the center of the dipoles is 2.7 mm away from the tip of the probe and the distance between the surface and the lowest measuring point is 1.4 mm (see probe calibration document in Appendix D). The extrapolation was based on trivariate quadratics computed from the previously calculated 3D interpolated points nearest the phantom surface.
- f. Interpolated data is used to calculate the average SAR over 1g and 10g cubes by spatially discretizing the entire measured cube. The volume used to determine the averaged SAR is a 1mm grid (42875 interpolated points).

7.0 SYSTEM PERFORMANCE CHECK

Prior to the SAR evaluation a system check was performed using a planar phantom with a 450MHz dipole (see Appendix C for system validation procedure). The dielectric parameters of the simulated tissue fluids were measured prior to the system check using an 85070C Dielectric Probe Kit and an 8753E Network Analyzer (see Appendix E for printout of measured fluid dielectric parameters). A forward power of 250mW was applied to the dipole and the system was verified to a tolerance of $\pm 10\%$ (see Appendix B for system performance check test plots).

SYSTEM PERFORMANCE CHECK													
Test Date	450MHz Equiv. Tissue	SAR 1g (W/kg)		Dielectric Constant ϵ_r		Conductivity σ (mho/m)		ρ (Kg/m ³)	Amb. Temp. (°C)	Fluid Temp. (°C)	Fluid Depth (cm)	Humid. (%)	Barom. Press. (kPa)
		IEEE Target	Measured	IEEE Target	Measured	IEEE Target	Measured						
12/17/03	Brain	1.23 ($\pm 10\%$)	1.29 (+4.9%)	43.5 $\pm 5\%$	42.9	0.87 $\pm 5\%$	0.84	1000	24.4	21.4	≥ 15	33	98.1
12/18/03	Brain	1.23 ($\pm 10\%$)	1.31 (+6.5%)	43.5 $\pm 5\%$	43.2	0.87 $\pm 5\%$	0.85	1000	24.0	20.9	≥ 15	35	98.2

Note(s):

- The ambient and fluid temperatures were measured prior to, and during, the fluid dielectric parameter check and the system performance check. The temperatures listed in the table above were consistent for all measurement periods.

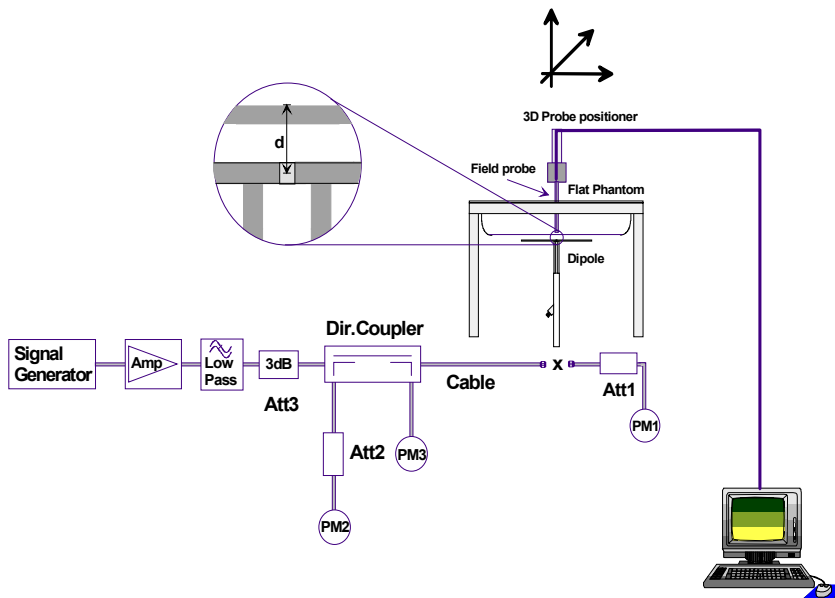
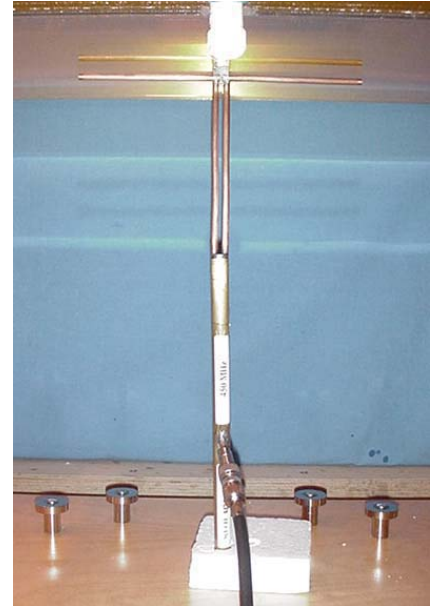

Figure 1. System Performance Check Setup Diagram



450MHz Dipole Setup

8.0 SIMULATED EQUIVALENT TISSUES

The 450MHz brain and body simulated tissue mixtures consist of a viscous gel using hydroxyethylcellulose (HEC) gelling agent and saline solution. Preservation with a bactericide is added and visual inspection is made to ensure air bubbles are not trapped during the mixing process. The fluid was prepared and measured for dielectric parameters (permittivity and conductivity) according to standardized procedures.

TISSUE SIMULANT MIXTURES		
INGREDIENT	450MHz Brain (System Check & DUT Evaluation)	450MHz Body (DUT Evaluation)
Water	38.56 %	52.00 %
Sugar	56.32 %	45.65 %
Salt	3.95 %	1.75 %
HEC	0.98 %	0.50 %
Bactericide	0.19 %	0.10 %

9.0 SAR SAFETY LIMITS

EXPOSURE LIMITS	SAR (W/kg)	
	(General Population / Uncontrolled Exposure Environment)	(Occupational / Controlled Exposure Environment)
Spatial Average (averaged over the whole body)	0.08	0.4
Spatial Peak (averaged over any 1g of tissue)	1.60	8.0
Spatial Peak (hands/wrists/feet/ankles averaged over 10g)	4.0	20.0

Notes:

1. Uncontrolled environments are defined as locations where there is potential exposure of individuals who have no knowledge or control of their potential exposure.
2. Controlled environments are defined as locations where there is potential exposure of individuals who have knowledge of their potential exposure and can exercise control over their exposure.

10.0 ROBOT SYSTEM SPECIFICATIONS

Specifications

POSITIONER: Stäubli Unimation Corp. Robot Model: RX60L
Repeatability: 0.02 mm
No. of axis: 6

Data Acquisition Electronic (DAE) System

Cell Controller

Processor: AMD Athlon XP 2400+
Clock Speed: 2.0 GHz
Operating System: Windows XP Professional

Data Converter

Features: Signal Amplifier, multiplexer, A/D converter, and control logic
Software: DASY4 software
Connecting Lines: Optical downlink for data and status info.
 Optical uplink for commands and clock

DASY4 Measurement Server

Function: Real-time data evaluation for field measurements and surface detection
Hardware: PC/104 166MHz Pentium CPU; 32 MB chipdisk; 64 MB RAM
Connections: COM1, COM2, DAE, Robot, Ethernet, Service Interface

E-Field Probe

Model: ET3DV6
Serial No.: 1387
Construction: Triangular core fiber optic detection system
Frequency: 10 MHz to 6 GHz
Linearity: ± 0.2 dB (30 MHz to 3 GHz)

Phantom(s)

Evaluation Phantom

Type: Planar Phantom
Shell Material: Plexiglas
Bottom Thickness: 2.0 mm \pm 0.1 mm
Outer Dimensions: 75.0 cm (L) x 22.5 cm (W) x 20.5 cm (H); Back Plane: 25.7 cm (H)

Validation Phantom (≤ 450 MHz)

Type: Planar Phantom
Shell Material: Plexiglas
Bottom Thickness: 6.2 mm \pm 0.1 mm
Outer Dimensions: 86.0 cm (L) x 39.5 cm (W) x 21.8 cm (H)

11.0 PROBE SPECIFICATION (ET3DV6)

Construction:	Symmetrical design with triangular core Built-in shielding against static charges PEEK enclosure material (resistant to organic solvents, e.g. glycol)
Calibration:	In air from 10 MHz to 2.5 GHz In brain simulating tissue at frequencies of 900 MHz and 1.8 GHz (accuracy $\pm 8\%$)
Frequency:	10 MHz to > 6 GHz; Linearity: ± 0.2 dB (30 MHz to 3 GHz)
Directivity:	± 0.2 dB in brain tissue (rotation around probe axis) ± 0.4 dB in brain tissue (rotation normal to probe axis)
Dynamic Range:	5 μ W/g to > 100 mW/g; Linearity: ± 0.2 dB
Surface Detection:	± 0.2 mm repeatability in air and clear liquids over diffuse reflecting surfaces
Dimensions:	Overall length: 330 mm Tip length: 16 mm Body diameter: 12 mm Tip diameter: 6.8 mm Distance from probe tip to dipole centers: 2.7 mm
Application:	General dosimetry up to 3 GHz Compliance tests of mobile phone



ET3DV6 E-Field Probe

12.0 PLANAR PHANTOM

The planar phantom is constructed of Plexiglas material with a 2.0 mm shell thickness for face-held and body-worn SAR evaluations of handheld radio transceivers. The planar phantom is mounted on the side of the DASY4 system.



Planar Phantom

13.0 VALIDATION PLANAR PHANTOM

The validation planar phantom is constructed of Plexiglas material with a 6.0 mm shell thickness for system validations at 450MHz and below. The validation planar phantom is mounted in the DASY4 system.



Validation Planar Phantom

14.0 DEVICE HOLDER

The DASY4 device holder has two scales for device rotation (with respect to the body axis) and the device inclination (with respect to the line between the ear openings). The plane between the ear openings and the mouth tip has a rotation angle of 65°. The bottom plate contains three pair of bolts for locking the device holder. The device holder positions are adjusted to the standard measurement positions in the three sections.



Device Holder

15.0 TEST EQUIPMENT LIST

TEST EQUIPMENT	SERIAL NO.	CALIBRATION DATE
Schmid & Partner DASY4 System	-	-
DASY4 Measurement Server	1078	N/A
-Robot	599396-01	N/A
-ET3DV6 E-Field Probe	1387	Feb 2003
-300MHz Validation Dipole	135	Oct 2003
-450MHz Validation Dipole	136	Nov 2003
-900MHz Validation Dipole	054	June 2003
-1800MHz Validation Dipole	247	June 2003
-2450MHz Validation Dipole	150	Sept 2003
-Planar Phantom	161	N/A
-Validation Planar Phantom	137	N/A
HP 85070C Dielectric Probe Kit	N/A	N/A
Gigatronics 8651A Power Meter	8650137	April 2003
Gigatronics 8652A Power Meter	1835267	April 2003
Power Sensor 80701A	1833542	Feb 2003
Power Sensor 80701A	1833699	April 2003
HP E4408B Spectrum Analyzer	US39240170	Dec 2003
HP 8594E Spectrum Analyzer	3543A02721	April 2003
HP 8753E Network Analyzer	US38433013	May 2003
HP 8648D Signal Generator	3847A00611	May 2003
Amplifier Research 5S1G4 Power Amplifier	26235	N/A

16.0 MEASUREMENT UNCERTAINTIES

UNCERTAINTY BUDGET FOR DEVICE EVALUATION						
Error Description	Uncertainty Value ±%	Probability Distribution	Divisor	C_i 1g	Standard Uncertainty ±% (1g)	V_i OR V_{eff}
Measurement System						
Probe calibration	± 4.8	Normal	1	1	± 4.8	∞
Axial isotropy of the probe	± 4.7	Rectangular	√3	(1- C_p)	± 1.9	∞
Spherical isotropy of the probe	± 9.6	Rectangular	√3	(C_p)	± 3.9	∞
Spatial resolution	± 0.0	Rectangular	√3	1	± 0.0	∞
Boundary effects	± 5.5	Rectangular	√3	1	± 3.2	∞
Probe linearity	± 4.7	Rectangular	√3	1	± 2.7	∞
Detection limit	± 1.0	Rectangular	√3	1	± 0.6	∞
Readout electronics	± 1.0	Normal	1	1	± 1.0	∞
Response time	± 0.8	Rectangular	√3	1	± 0.5	∞
Integration time	± 1.4	Rectangular	√3	1	± 0.8	∞
RF ambient conditions	± 3.0	Rectangular	√3	1	± 1.7	∞
Mech. constraints of robot	± 0.4	Rectangular	√3	1	± 0.2	∞
Probe positioning	± 2.9	Rectangular	√3	1	± 1.7	∞
Extrapolation & integration	± 3.9	Rectangular	√3	1	± 2.3	∞
Test Sample Related						
Device positioning	± 6.0	Normal	√3	1	± 6.7	12
Device holder uncertainty	± 5.0	Normal	√3	1	± 5.9	8
Power drift	± 5.0	Rectangular	√3		± 2.9	∞
Phantom and Setup						
Phantom uncertainty	± 4.0	Rectangular	√3	1	± 2.3	∞
Liquid conductivity (target)	± 5.0	Rectangular	√3	0.6	± 1.7	∞
Liquid conductivity (measured)	± 5.0	Rectangular	√3	0.6	± 1.7	∞
Liquid permittivity (target)	± 5.0	Rectangular	√3	0.6	± 1.7	∞
Liquid permittivity (measured)	± 5.0	Rectangular	√3	0.6	± 1.7	∞
Combined Standard Uncertainty					± 13.3	
Expanded Uncertainty (k=2)					± 26.6	

Measurement Uncertainty Table in accordance with IEEE Standard 1528-200X (Draft - see reference [5])

MEASUREMENT UNCERTAINTIES (Cont.)

UNCERTAINTY BUDGET FOR SYSTEM VALIDATION						
Error Description	Uncertainty Value ±%	Probability Distribution	Divisor	C_i 1g	Standard Uncertainty ±% (1g)	V_i Or V_{eff}
Measurement System						
Probe calibration	± 4.8	Normal	1	1	± 4.8	∞
Axial isotropy of the probe	± 4.7	Rectangular	√3	(1- C_p)	± 1.9	∞
Spherical isotropy of the probe	± 9.6	Rectangular	√3	(C_p)	± 3.9	∞
Spatial resolution	± 0.0	Rectangular	√3	1	± 0.0	∞
Boundary effects	± 5.5	Rectangular	√3	1	± 3.2	∞
Probe linearity	± 4.7	Rectangular	√3	1	± 2.7	∞
Detection limit	± 1.0	Rectangular	√3	1	± 0.6	∞
Readout electronics	± 1.0	Normal	1	1	± 1.0	∞
Response time	± 0.8	Rectangular	√3	1	± 0.5	∞
Integration time	± 1.4	Rectangular	√3	1	± 0.8	∞
RF ambient conditions	± 3.0	Rectangular	√3	1	± 1.7	∞
Mech. constraints of robot	± 0.4	Rectangular	√3	1	± 0.2	∞
Probe positioning	± 2.9	Rectangular	√3	1	± 1.7	∞
Extrapolation & integration	± 3.9	Rectangular	√3	1	± 2.3	∞
Dipole						
Dipole Axis to Liquid Distance	± 2.0	Rectangular	√3	1	± 1.2	∞
Input Power	± 4.7	Rectangular	√3	1	± 2.7	∞
Phantom and Setup						
Phantom uncertainty	± 4.0	Rectangular	√3	1	± 2.3	∞
Liquid conductivity (target)	± 5.0	Rectangular	√3	0.6	± 1.7	∞
Liquid conductivity (measured)	± 5.0	Rectangular	√3	0.6	± 1.7	∞
Liquid permittivity (target)	± 5.0	Rectangular	√3	0.6	± 1.7	∞
Liquid permittivity (measured)	± 5.0	Rectangular	√3	0.6	± 1.7	∞
Combined Standard Uncertainty					± 9.9	
Expanded Uncertainty (k=2)					± 19.8	

Measurement Uncertainty Table in accordance with IEEE Standard 1528-200X (Draft - see reference [5])

17.0 REFERENCES

- [1] Federal Communications Commission, "Radiofrequency radiation exposure evaluation: portable devices", Rule Part 47 CFR §2.1093: 1999.
- [2] Health Canada, "Limits of Human Exposure to Radiofrequency Electromagnetic Fields in the Frequency Range from 3 kHz to 300 GHz", Safety Code 6.
- [3] Federal Communications Commission, "Evaluating Compliance with FCC Guidelines for Human Exposure to Radio frequency Electromagnetic Fields", OET Bulletin 65, Supplement C (Edition 01-01), FCC, Washington, D.C.: June 2001.
- [4] Industry Canada, "Evaluation Procedure for Mobile and Portable Radio Transmitters with respect to Health Canada's Safety Code 6 for Exposure of Humans to Radio Frequency Fields", Radio Standards Specification RSS-102 Issue 1 (Provisional): September 1999.
- [5] IEEE Standards Coordinating Committee 34, Std 1528-200X, "DRAFT Recommended Practice for Determining the Spatial-Peak Specific Absorption Rate (SAR) in the Human Body Due to Wireless Communications Devices: Experimental Techniques".

Test Report S/N:	120403-451ALH
Test Date(s):	December 17-18, 2003
Test Type:	FCC/IC SAR Evaluation

APPENDIX A - SAR MEASUREMENT DATA

Date Tested: 12/17/03

DUT: Kenwood Model: TK-3202-1; Type: Portable UHF PTT Radio Transceiver; Serial: U12

Ambient Temp: 24.4 °C; Fluid Temp: 21.4 °C; Barometric Pressure: 98.1 kPa; Humidity: 33%

Communication System: FM UHF
 Frequency: 470 MHz; Duty Cycle: 1:1
 7.5 V NiCd Battery Pack (P/N: KNB-30A)
 RF Output Power: 36.28 dBm (Conducted)
 Medium: HSL450 ($\sigma = 0.84$ mho/m, $\epsilon_r = 42.9$, $\rho = 1000$ kg/m³)

- Probe: ET3DV6 - SN1387; ConvF(7.5, 7.5, 7.5); Calibrated: 26/02/2003
- Sensor-Surface: 4mm (Mechanical Surface Detection)
- Electronics: DAE3 Sn370; Calibrated: 19/05/2003
- Phantom: Planar; Type: Plexiglas; Serial: 161
- Measurement SW: DASY4, V4.1 Build 47; Postprocessing SW: SEMCAD, V1.6 Build 116

Face-Held - Stubby Antenna - 2.5 cm Separation Distance - Mid Channel/Area Scan (7x15x1):
 Measurement grid: dx=15mm, dy=15mm

Face-Held - Stubby Antenna - 2.5 cm Separation Distance - Mid Channel/Zoom Scan (7x7x7)/Cube 0:
 Measurement grid: dx=5mm, dy=5mm, dz=5mm
 Peak SAR (extrapolated) = 9.57 W/kg
SAR(1 g) = 6.07 mW/g; SAR(10 g) = 4.28 mW/g
 Reference Value = 90.8 V/m

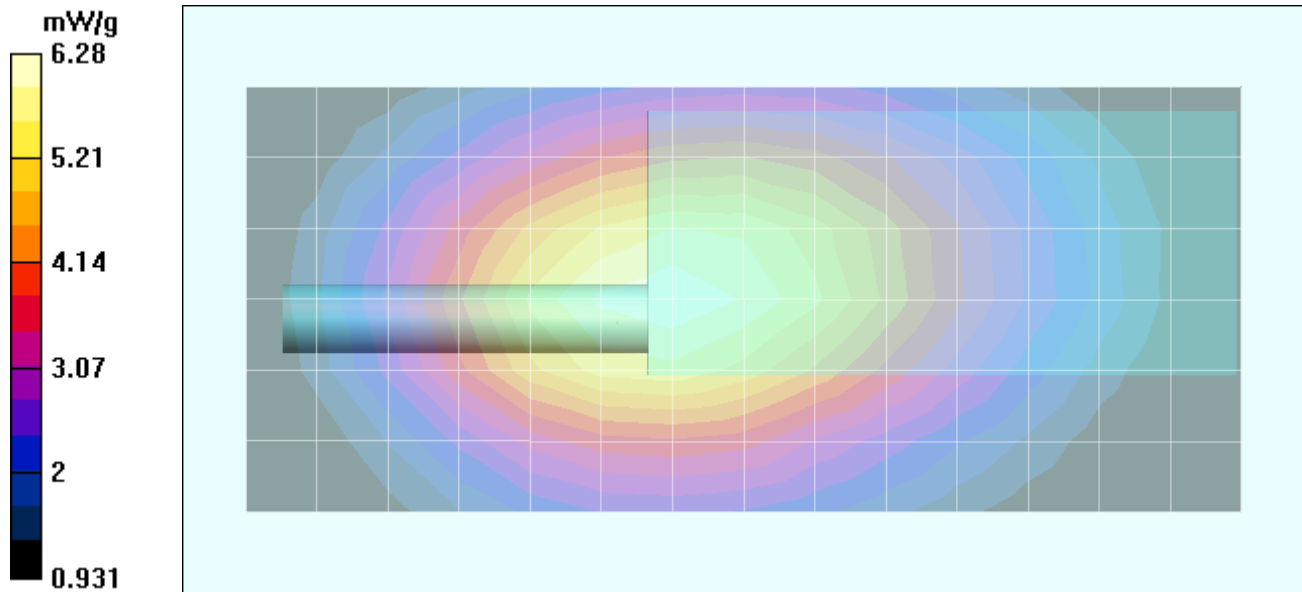

Date Tested: 12/17/03

DUT: Kenwood Model: TK-3202-1; Type: Portable UHF PTT Radio Transceiver; Serial: U12

Ambient Temp: 24.4 °C; Fluid Temp: 21.4 °C; Barometric Pressure: 98.1 kPa; Humidity: 33%

Communication System: FM UHF
 Frequency: 470 MHz; Duty Cycle: 1:1
 7.5 V NiMH Battery Pack (P/N: KNB-29N)
 RF Output Power: 36.24 dBm (Conducted)
 Medium: HSL450 ($\sigma = 0.84$ mho/m, $\epsilon_r = 42.9$, $\rho = 1000$ kg/m³)

- Probe: ET3DV6 - SN1387; ConvF(7.5, 7.5, 7.5); Calibrated: 26/02/2003
- Sensor-Surface: 4mm (Mechanical Surface Detection)
- Electronics: DAE3 Sn370; Calibrated: 19/05/2003
- Phantom: Planar; Type: Plexiglas; Serial: 161
- Measurement SW: DASY4, V4.1 Build 47; Postprocessing SW: SEMCAD, V1.6 Build 116

Face-Held - Stubby Antenna - 2.5 cm Separation Distance - Mid Channel/Area Scan (7x15x1):
 Measurement grid: dx=15mm, dy=15mm

Face-Held - Stubby Antenna - 2.5 cm Separation Distance - Mid Channel/Zoom Scan (7x7x7)/Cube 0:
 Measurement grid: dx=5mm, dy=5mm, dz=5mm
 Peak SAR (extrapolated) = 9.65 W/kg
SAR(1 g) = 6.10 mW/g; SAR(10 g) = 4.28 mW/g
 Reference Value = 95.5 V/m

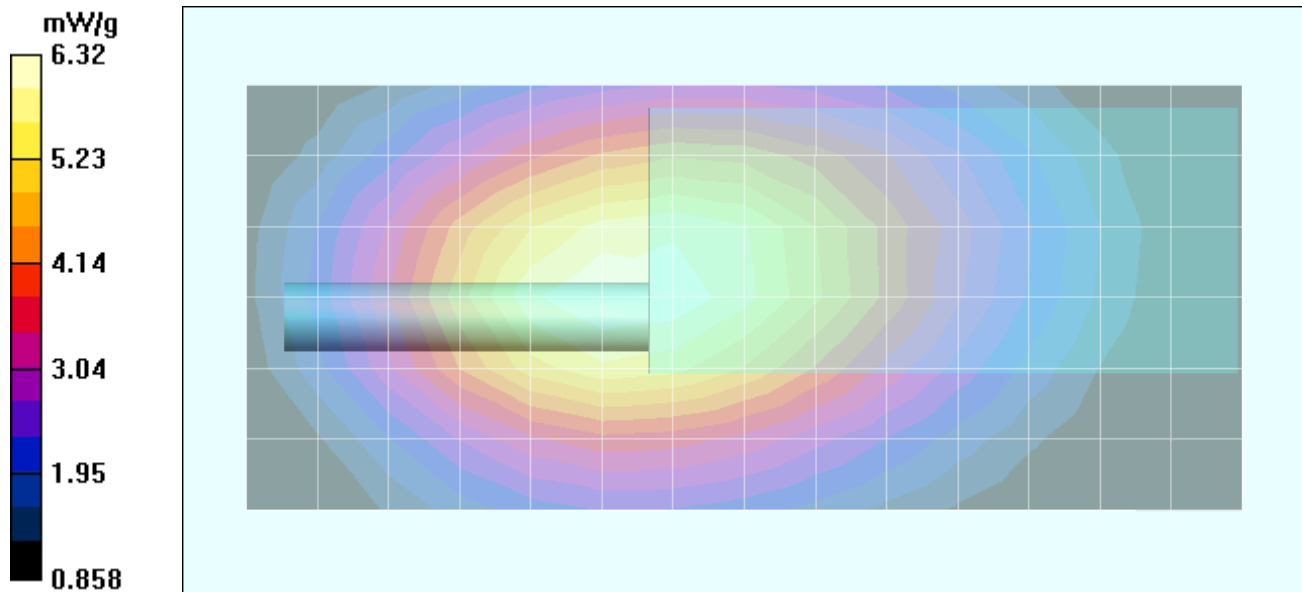

Date Tested: 12/17/03

DUT: Kenwood Model: TK-3202-1; Type: Portable UHF PTT Radio Transceiver; Serial: U12

Ambient Temp: 24.4 °C; Fluid Temp: 21.4 °C; Barometric Pressure: 98.1 kPa; Humidity: 33%

Communication System: FM UHF
 Frequency: 470 MHz; Duty Cycle: 1:1
 7.5 V NiCd Battery Pack (P/N: KNB-30A)
 RF Output Power: 36.20 dBm (Conducted)
 Medium: HSL450 ($\sigma = 0.84$ mho/m, $\epsilon_r = 42.9$, $\rho = 1000$ kg/m³)

- Probe: ET3DV6 - SN1387; ConvF(7.5, 7.5, 7.5); Calibrated: 26/02/2003
- Sensor-Surface: 4mm (Mechanical Surface Detection)
- Electronics: DAE3 Sn370; Calibrated: 19/05/2003
- Phantom: Planar; Type: Plexiglas; Serial: 161
- Measurement SW: DASY4, V4.1 Build 47; Postprocessing SW: SEMCAD, V1.6 Build 116

Face-Held - Whip Antenna - 2.5 cm Separation Distance - Mid Channel/Area Scan (7x20x1):
 Measurement grid: dx=15mm, dy=15mm

Face-Held - Whip Antenna - 2.5 cm Separation Distance - Mid Channel/Zoom Scan (7x7x7)/Cube 0:
 Measurement grid: dx=5mm, dy=5mm, dz=5mm
 Peak SAR (extrapolated) = 10.8 W/kg
SAR(1 g) = 6.76 mW/g; SAR(10 g) = 4.74 mW/g
 Reference Value = 95.9 V/m

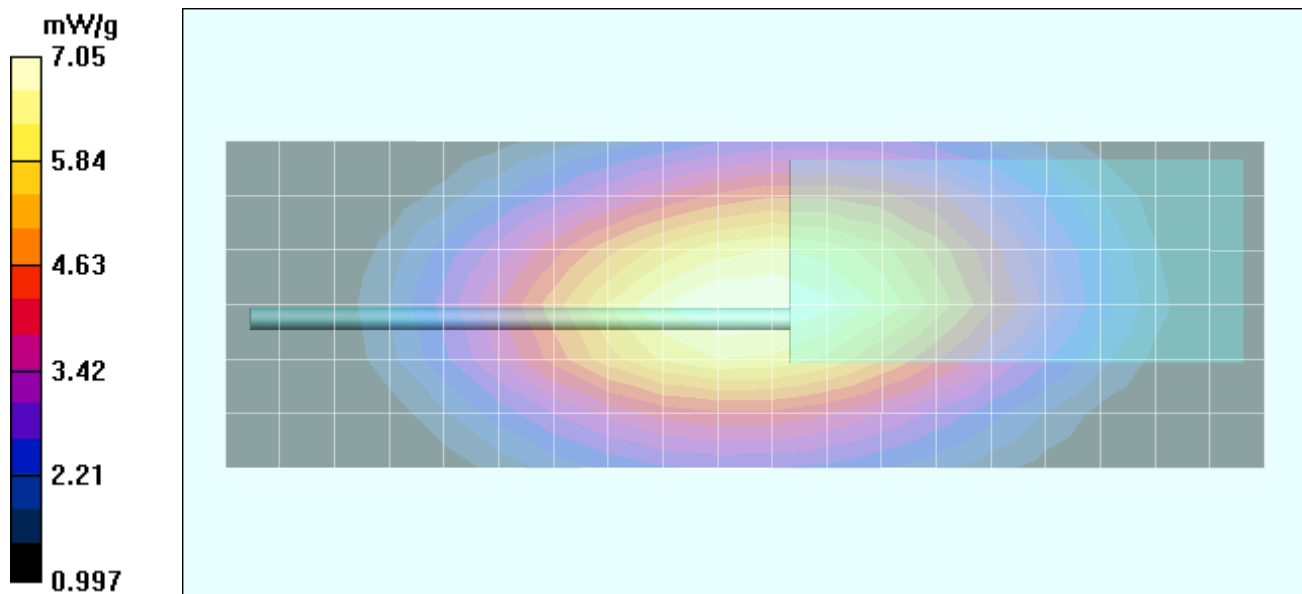

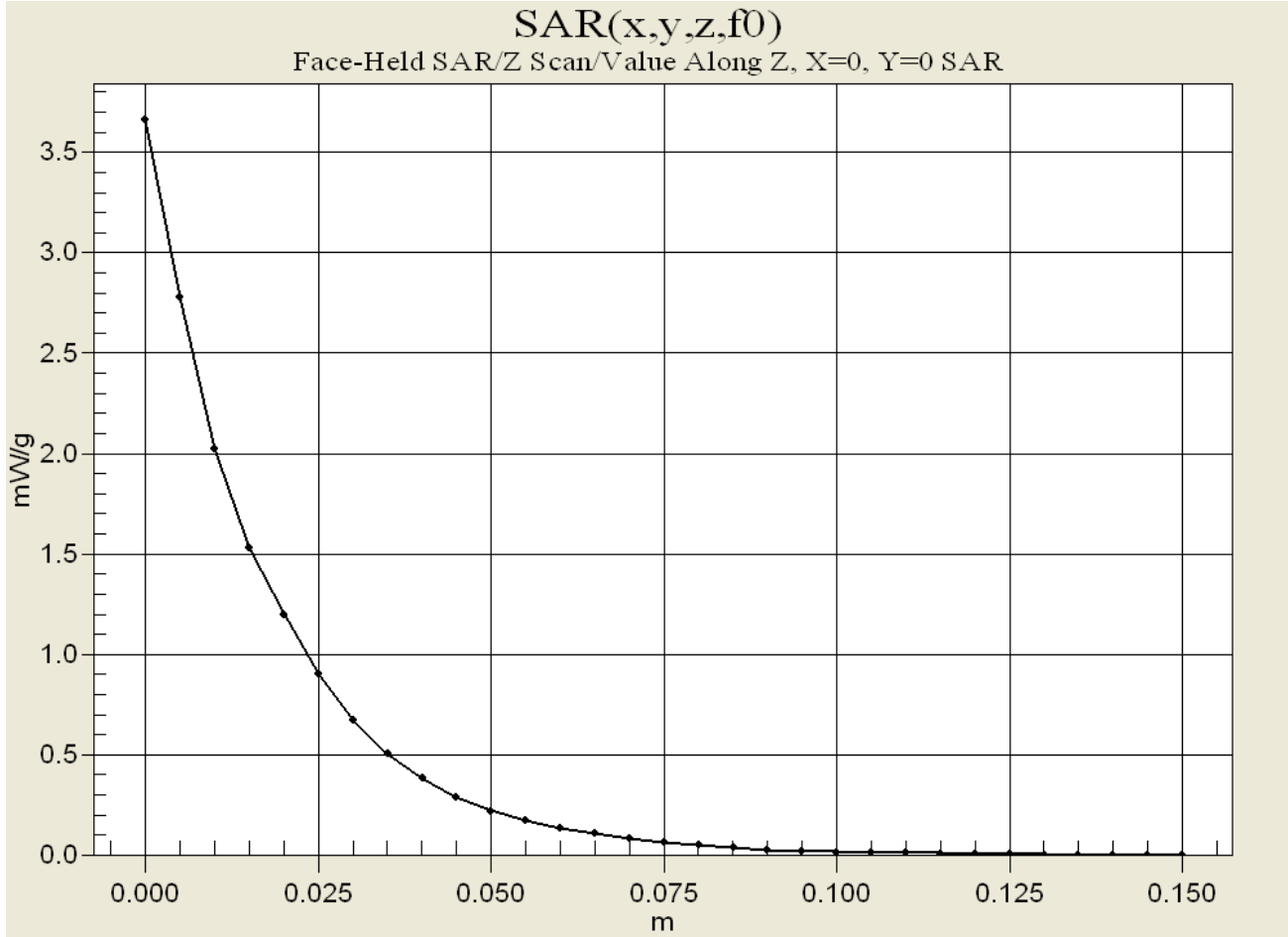

Date Tested: 12/17/03

DUT: Kenwood Model: TK-3202-1; Type: Portable UHF PTT Radio Transceiver; Serial: U12

Ambient Temp: 24.4 °C; Fluid Temp: 21.4 °C; Barometric Pressure: 98.1 kPa; Humidity: 33%

Communication System: FM UHF
 Frequency: 470 MHz; Duty Cycle: 1:1
 7.5 NiMH Battery Pack (P/N: KNB-29N)
 RF Output Power: 36.24 dBm (Conducted)
 Medium: HSL450 ($\sigma = 0.84$ mho/m, $\epsilon_r = 42.9$, $\rho = 1000$ kg/m³)

- Probe: ET3DV6 - SN1387; ConvF(7.5, 7.5, 7.5); Calibrated: 26/02/2003
- Sensor-Surface: 4mm (Mechanical Surface Detection)
- Electronics: DAE3 Sn370; Calibrated: 19/05/2003
- Phantom: Planar; Type: Plexiglas; Serial: 161
- Measurement SW: DASY4, V4.1 Build 47; Postprocessing SW: SEMCAD, V1.6 Build 116

Face-Held - Whip Antenna - 2.5 cm Separation Distance - Mid Channel/Area Scan (7x20x1):
 Measurement grid: dx=15mm, dy=15mm

Face-Held - Whip Antenna - 2.5 cm Separation Distance - Mid Channel/Zoom Scan (7x7x7)/Cube 0:
 Measurement grid: dx=5mm, dy=5mm, dz=5mm
 Peak SAR (extrapolated) = 10.3 W/kg
SAR(1 g) = 6.53 mW/g; SAR(10 g) = 4.6 mW/g
 Reference Value = 96.3 V/m

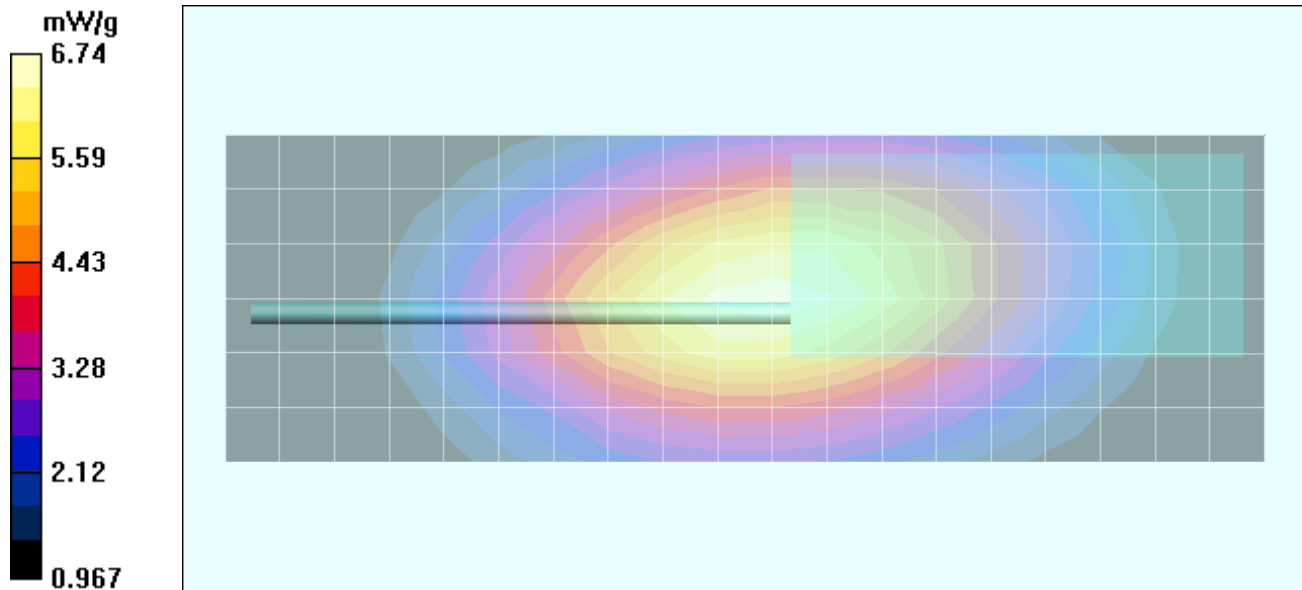

Date Tested: 12/17/03

DUT: Kenwood Model: TK-3202-1; Type: Portable UHF PTT Radio Transceiver; Serial: U12

Ambient Temp: 24.4 °C; Fluid Temp: 21.4 °C; Barometric Pressure: 98.1 kPa; Humidity: 33%

Communication System: FM UHF
 Frequency: 450 MHz; Duty Cycle: 1:1
 7.5V NiCd Battery Pack (P/N: KNB-30A)
 RF Output Power: 36.42 dBm (Conducted)
 Medium: HSL450 ($\sigma = 0.84$ mho/m, $\epsilon_r = 42.9$, $\rho = 1000$ kg/m³)

- Probe: ET3DV6 - SN1387; ConvF(7.5, 7.5, 7.5); Calibrated: 26/02/2003
- Sensor-Surface: 4mm (Mechanical Surface Detection)
- Electronics: DAE3 Sn370; Calibrated: 19/05/2003
- Phantom: Planar; Type: Plexiglas; Serial: 161
- Measurement SW: DASY4, V4.1 Build 47; Postprocessing SW: SEMCAD, V1.6 Build 116

Face-Held - Whip Antenna - 2.5 cm Separation Distance - Low Channel/Area Scan (7x20x1):

Measurement grid: dx=15mm, dy=15mm

Face-Held - Whip Antenna - 2.5 cm Separation Distance - Low Channel/Zoom Scan (7x7x7)/Cube 0:

Measurement grid: dx=5mm, dy=5mm, dz=5mm

Peak SAR (extrapolated) = 8.56 W/kg

SAR(1 g) = 5.37 mW/g; SAR(10 g) = 3.77 mW/g

Reference Value = 83.1 V/m

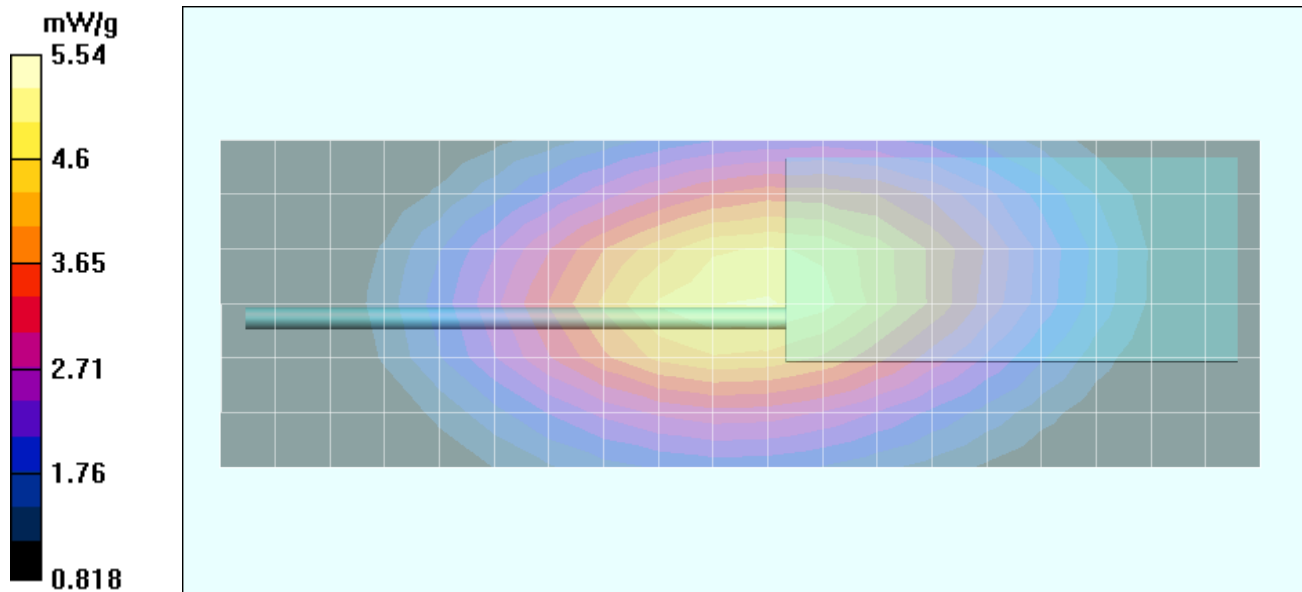

Date Tested: 12/17/03

DUT: Kenwood Model: TK-3202-1; Type: Portable UHF PTT Radio Transceiver; Serial: U12

Ambient Temp: 24.4 °C; Fluid Temp: 21.4 °C; Barometric Pressure: 98.1 kPa; Humidity: 33%

Communication System: FM UHF
 Frequency: 490 MHz; Duty Cycle: 1:1
 7.5V NiCd Battery Pack (P/N: KNB-30A)
 RF Output Power: 36.20 dBm (Conducted)
 Medium: HSL450 ($\sigma = 0.84$ mho/m, $\epsilon_r = 42.9$, $\rho = 1000$ kg/m³)

- Probe: ET3DV6 - SN1387; ConvF(7.5, 7.5, 7.5); Calibrated: 26/02/2003
- Sensor-Surface: 4mm (Mechanical Surface Detection)
- Electronics: DAE3 Sn370; Calibrated: 19/05/2003
- Phantom: Planar; Type: Plexiglas; Serial: 161
- Measurement SW: DASY4, V4.1 Build 47; Postprocessing SW: SEMCAD, V1.6 Build 116

Face-Held - Whip Antenna - 2.5 cm Separation Distance - High Channel/Area Scan (7x20x1):

Measurement grid: dx=15mm, dy=15mm

Face-Held - Whip Antenna - 2.5 cm Separation Distance - High Channel/Zoom Scan (7x7x7)/Cube 0:

Measurement grid: dx=5mm, dy=5mm, dz=5mm

Peak SAR (extrapolated) = 8.64 W/kg

SAR(1 g) = 5.45 mW/g; SAR(10 g) = 3.82 mW/g

Reference Value = 84.9 V/m

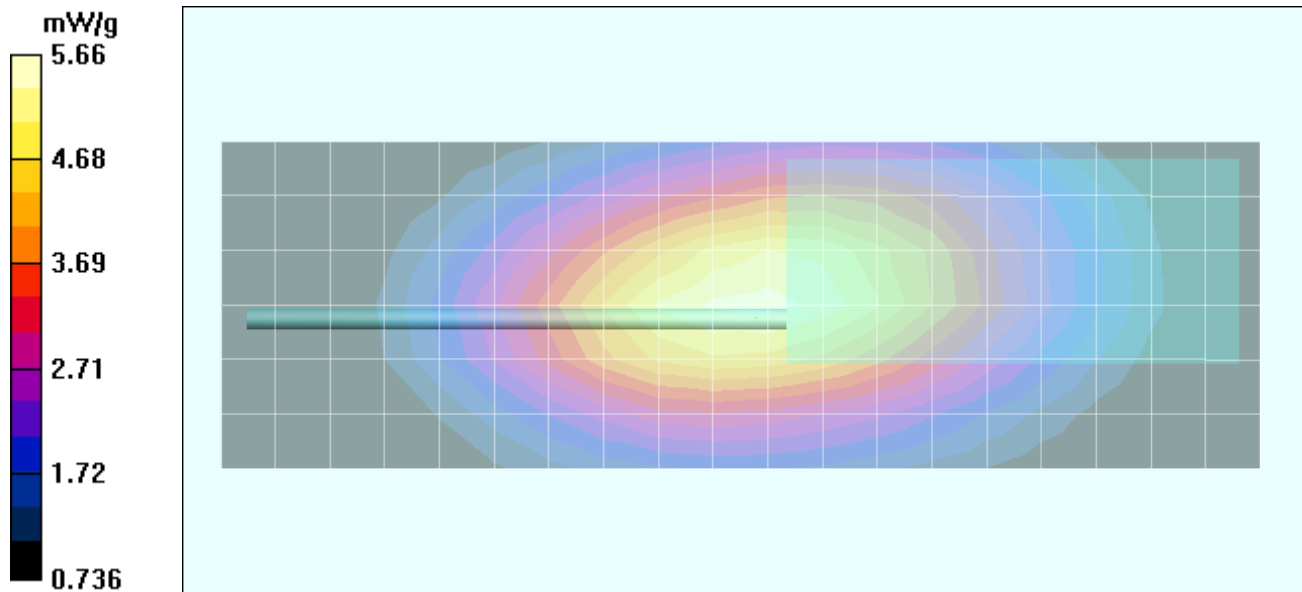

Date Tested: 12/18/03

DUT: Kenwood Model: TK-3202-1; Type: Portable UHF PTT Radio Transceiver; Serial: U12

Ambient Temp: 24.4 °C; Fluid Temp: 20.8 °C Barometric Pressure: 98.2 kPa; Humidity: 35%

Body-worn Accessories: Belt-Clip, Speaker-Microphone

Communication System: FM UHF
 Frequency: 470 MHz; Duty Cycle: 1:1
 7.5 NiCd Battery Pack (P/N: KNB-30A)
 RF Output Power: 36.26 dBm (Conducted)
 Medium: M450 ($\sigma = 0.91$ mho/m, $\epsilon_r = 56.3$, $\rho = 1000$ kg/m³)

- Probe: ET3DV6 - SN1387; ConvF(7.7, 7.7, 7.7); Calibrated: 26/02/2003
- Sensor-Surface: 4mm (Mechanical Surface Detection)
- Electronics: DAE3 Sn370; Calibrated: 19/05/2003
- Phantom: Planar; Type: Plexiglas; Serial: 161
- Measurement SW: DASY4, V4.1 Build 47; Postprocessing SW: SEMCAD, V1.6 Build 116

Body-Worn - Stubby Antenna - 1.1 cm Belt-Clip Separation Distance - Mid Channel/Area Scan (7x15x1):
 Measurement grid: dx=15mm, dy=15mm

Body-Worn - Stubby Antenna - 1.1 cm Belt-Clip Separation Distance - Mid Channel/Zoom Scan (7x7x7)/Cube 0:
 Measurement grid: dx=5mm, dy=5mm, dz=5mm
 Peak SAR (extrapolated) = 12.9 W/kg
SAR(1 g) = 7.99 mW/g; SAR(10 g) = 5.49 mW/g
 Reference Value = 95.3 V/m

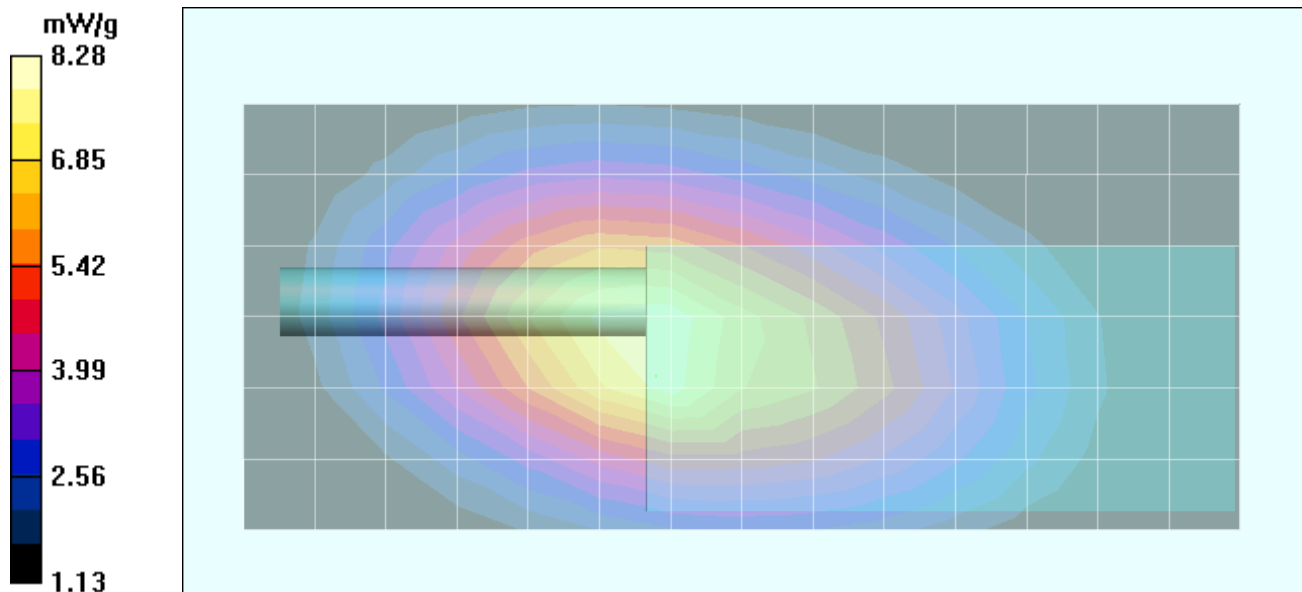

Date Tested: 12/18/03

DUT: Kenwood Model: TK-3202-1; Type: Portable UHF PTT Radio Transceiver; Serial: U12

Ambient Temp: 24.4 °C; Fluid Temp: 20.8 °C; Barometric Pressure: 98.2 kPa; Humidity: 35%

Body-worn Accessories: Belt-Clip, Speaker-Microphone

Communication System: FM UHF
 Frequency: 470 MHz; Duty Cycle: 1:1
 7.5V NiMH Battery Pack (P/N: KNB-29N)
 RF Output Power: 36.24 dBm (Conducted)
 Medium: M450 ($\sigma = 0.91$ mho/m, $\epsilon_r = 56.3$, $\rho = 1000$ kg/m³)

- Probe: ET3DV6 - SN1387; ConvF(7.7, 7.7, 7.7); Calibrated: 26/02/2003
- Sensor-Surface: 4mm (Mechanical Surface Detection)
- Electronics: DAE3 Sn370; Calibrated: 19/05/2003
- Phantom: Planar; Type: Plexiglas; Serial: 161
- Measurement SW: DASY4, V4.1 Build 47; Postprocessing SW: SEMCAD, V1.6 Build 116

Body-Worn - Stubby Antenna - 1.1 cm Belt-Clip Separation Distance- Mid Channel/Area Scan (7x15x1):

Measurement grid: dx=15mm, dy=15mm

Body-Worn - Stubby Antenna - 1.1 cm Belt-Clip Separation Distance - Mid Channel/Zoom Scan (7x7x7)/Cube 0:

Measurement grid: dx=5mm, dy=5mm, dz=5mm

Peak SAR (extrapolated) = 12.6 W/kg

SAR(1 g) = 7.85 mW/g; SAR(10 g) = 5.41 mW/g

Reference Value = 99.9 V/m

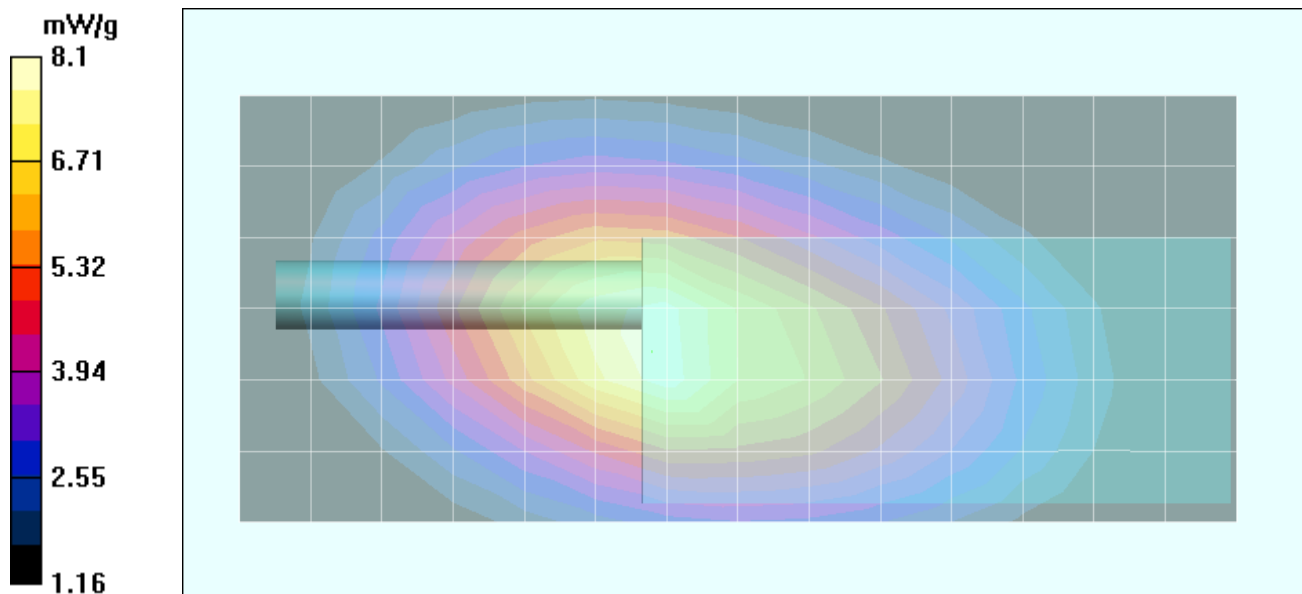

Date Tested: 12/18/03

DUT: Kenwood Model: TK-3202-1; Type: Portable UHF PTT Radio Transceiver; Serial: U12

Ambient Temp: 24.4 °C; Fluid Temp: 20.8 °C; Barometric Pressure: 98.2 kPa; Humidity: 35%

Body-worn Accessories: Belt-Clip, Speaker-Microphone

Communication System: FM UHF
 Frequency: 450 MHz; Duty Cycle: 1:1
 7.5 V NiCd Battery Pack (P/N: KNB-30A)
 RF Output Power: 36.48 dBm (Conducted)
 Medium: M450 ($\sigma = 0.91$ mho/m, $\epsilon_r = 56.3$, $\rho = 1000$ kg/m³)

- Probe: ET3DV6 - SN1387; ConvF(7.7, 7.7, 7.7); Calibrated: 26/02/2003
- Sensor-Surface: 4mm (Mechanical Surface Detection)
- Electronics: DAE3 Sn370; Calibrated: 19/05/2003
- Phantom: Planar; Type: Plexiglas; Serial: 161
- Measurement SW: DASY4, V4.1 Build 47; Postprocessing SW: SEMCAD, V1.6 Build 116

Body-Worn - Stubby Antenna - 1.1 cm Belt-Clip Separation Distance - Low Channel/Area Scan (7x15x1):

Measurement grid: dx=15mm, dy=15mm

Body-Worn - Stubby Antenna - 1.1 cm Belt-Clip Separation Distance - Low Channel/Zoom Scan (7x7x7)/Cube 0:

Measurement grid: dx=5mm, dy=5mm, dz=5mm

Peak SAR (extrapolated) = 10.5 W/kg

SAR(1 g) = 6.42 mW/g; SAR(10 g) = 4.39 mW/g

Reference Value = 91 V/m

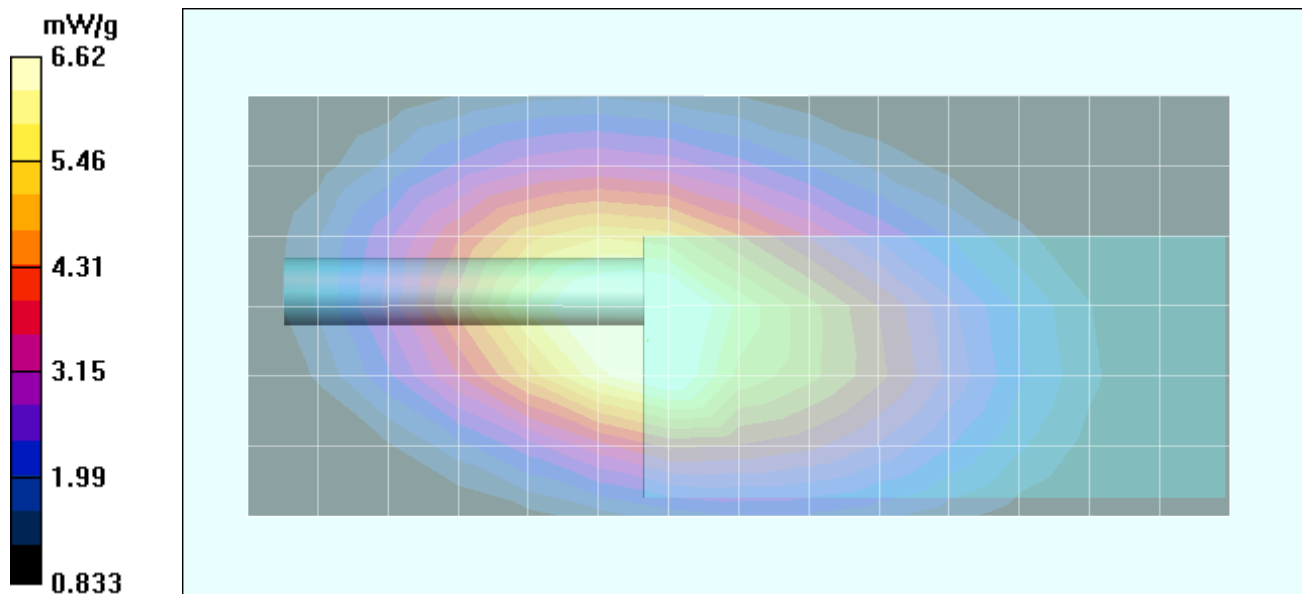

Date Tested: 12/18/03

DUT: Kenwood Model: TK-3202-1; Type: Portable UHF PTT Radio Transceiver; Serial: U12

Ambient Temp: 24.4 °C; Fluid Temp: 20.8 °C; Barometric Pressure: 98.2 kPa; Humidity: 35%

Body-worn Accessories: Belt-Clip, Speaker-Microphone

Communication System: FM UHF
 Frequency: 490 MHz; Duty Cycle: 1:1
 7.5V NiCd Battery Pack (P/N: KNB-30A)
 RF Output Power: 36.19 dBm (Conducted)
 Medium: M450 ($\sigma = 0.91$ mho/m, $\epsilon_r = 56.3$, $\rho = 1000$ kg/m³)

- Probe: ET3DV6 - SN1387; ConvF(7.7, 7.7, 7.7); Calibrated: 26/02/2003
- Sensor-Surface: 4mm (Mechanical Surface Detection)
- Electronics: DAE3 Sn370; Calibrated: 19/05/2003
- Phantom: Planar; Type: Plexiglas; Serial: 161
- Measurement SW: DASY4, V4.1 Build 47; Postprocessing SW: SEMCAD, V1.6 Build 116

Body-Worn - Stubby Antenna - 1.1 cm Belt-Clip Separation Distance - High Channel/Area Scan (7x15x1):

Measurement grid: dx=15mm, dy=15mm

Body-Worn - Stubby Antenna - 1.1 cm Belt-Clip Separation Distance - High Channel/Zoom Scan (7x7x7)/Cube 0:

Measurement grid: dx=5mm, dy=5mm, dz=5mm

Peak SAR (extrapolated) = 6.75 W/kg

SAR(1 g) = 4.17 mW/g; SAR(10 g) = 2.86 mW/g

Reference Value = 80.5 V/m

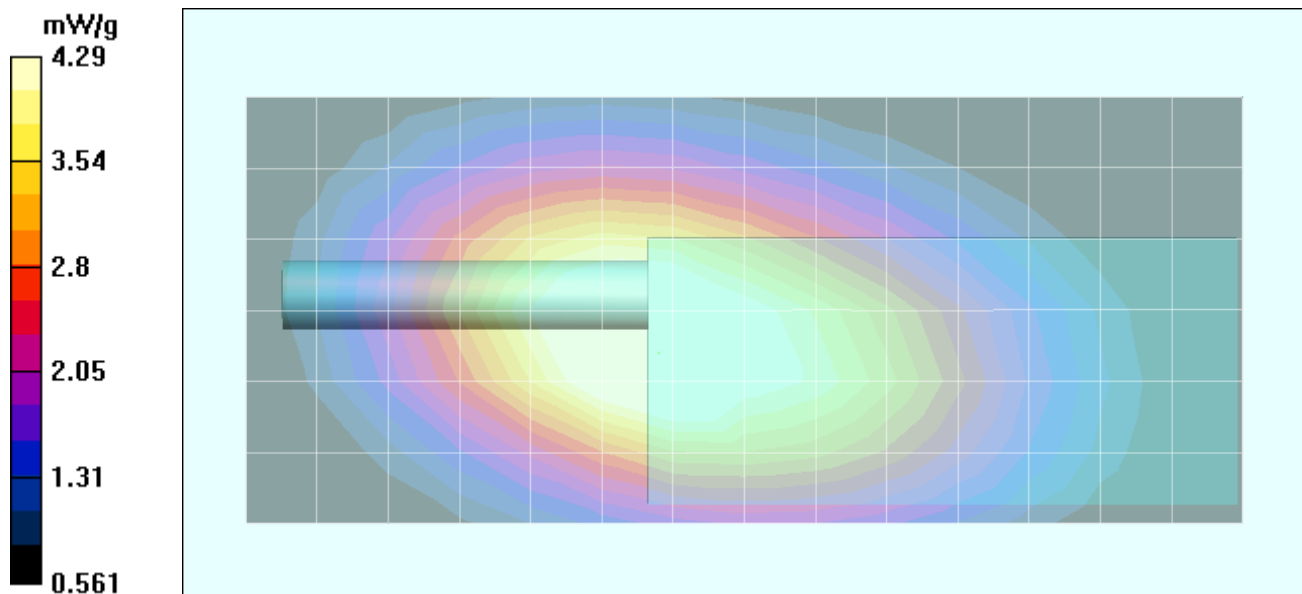

Date Tested: 12/18/03

DUT: Kenwood Model: TK-3202-1; Type: Portable UHF PTT Radio Transceiver; Serial: U12

Ambient Temp: 24.4 °C; Fluid Temp: 20.8 °C; Barometric Pressure: 98.2 kPa; Humidity: 35%

Body-worn Accessories: Belt-Clip, Speaker-Microphone

Communication System: FM UHF
 Frequency: 470 MHz; Duty Cycle: 1:1
 7.5V NiCd Battery Pack (P/N: KNB-30A)
 RF Output Power: 36.30 dBm (Conducted)
 Medium: M450 ($\sigma = 0.91$ mho/m, $\epsilon_r = 56.3$, $\rho = 1000$ kg/m³)

- Probe: ET3DV6 - SN1387; ConvF(7.7, 7.7, 7.7); Calibrated: 26/02/2003
- Sensor-Surface: 4mm (Mechanical Surface Detection)
- Electronics: DAE3 Sn370; Calibrated: 19/05/2003
- Phantom: Planar; Type: Plexiglas; Serial: 161
- Measurement SW: DASY4, V4.1 Build 47; Postprocessing SW: SEMCAD, V1.6 Build 116

Body-Worn - Whip Antenna - 1.1 cm Belt-Clip Separation Distance - Mid Channel/Area Scan (7x20x1):

Measurement grid: dx=15mm, dy=15mm

Body-Worn - Whip Antenna - 1.1 cm Belt-Clip Separation Distance - Mid Channel/Zoom Scan (7x7x7)/Cube 0:

Measurement grid: dx=5mm, dy=5mm, dz=5mm

Peak SAR (extrapolated) = 14 W/kg

SAR(1 g) = 8.70 mW/g; SAR(10 g) = 6.04 mW/g

Reference Value = 99.9 V/m

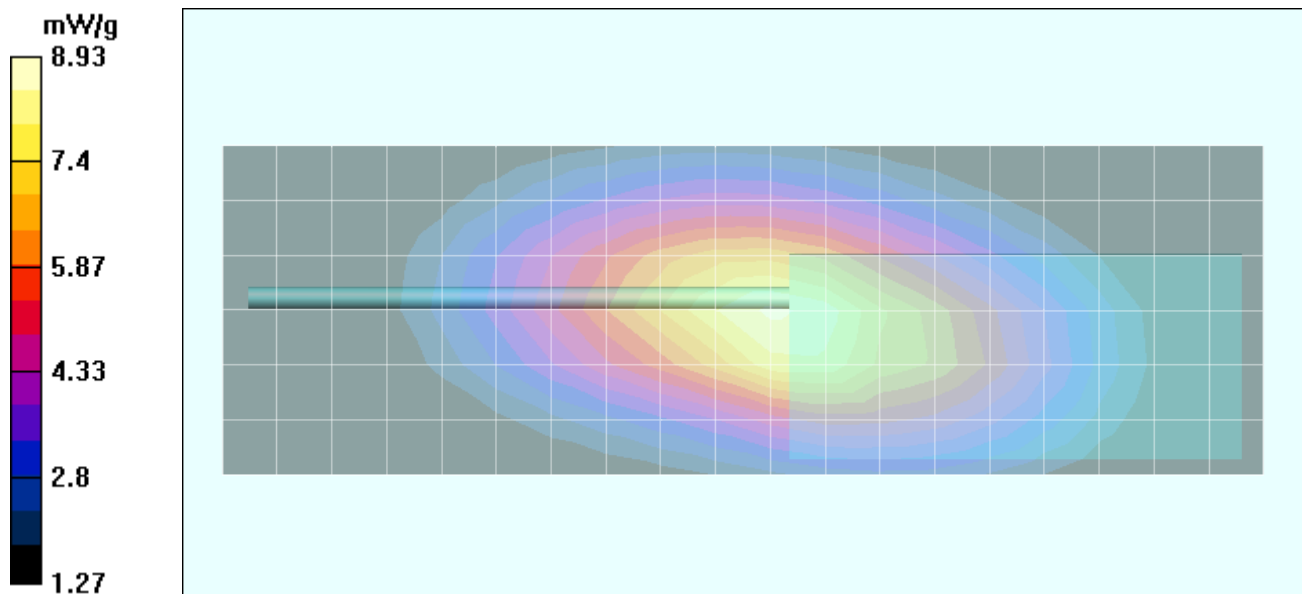

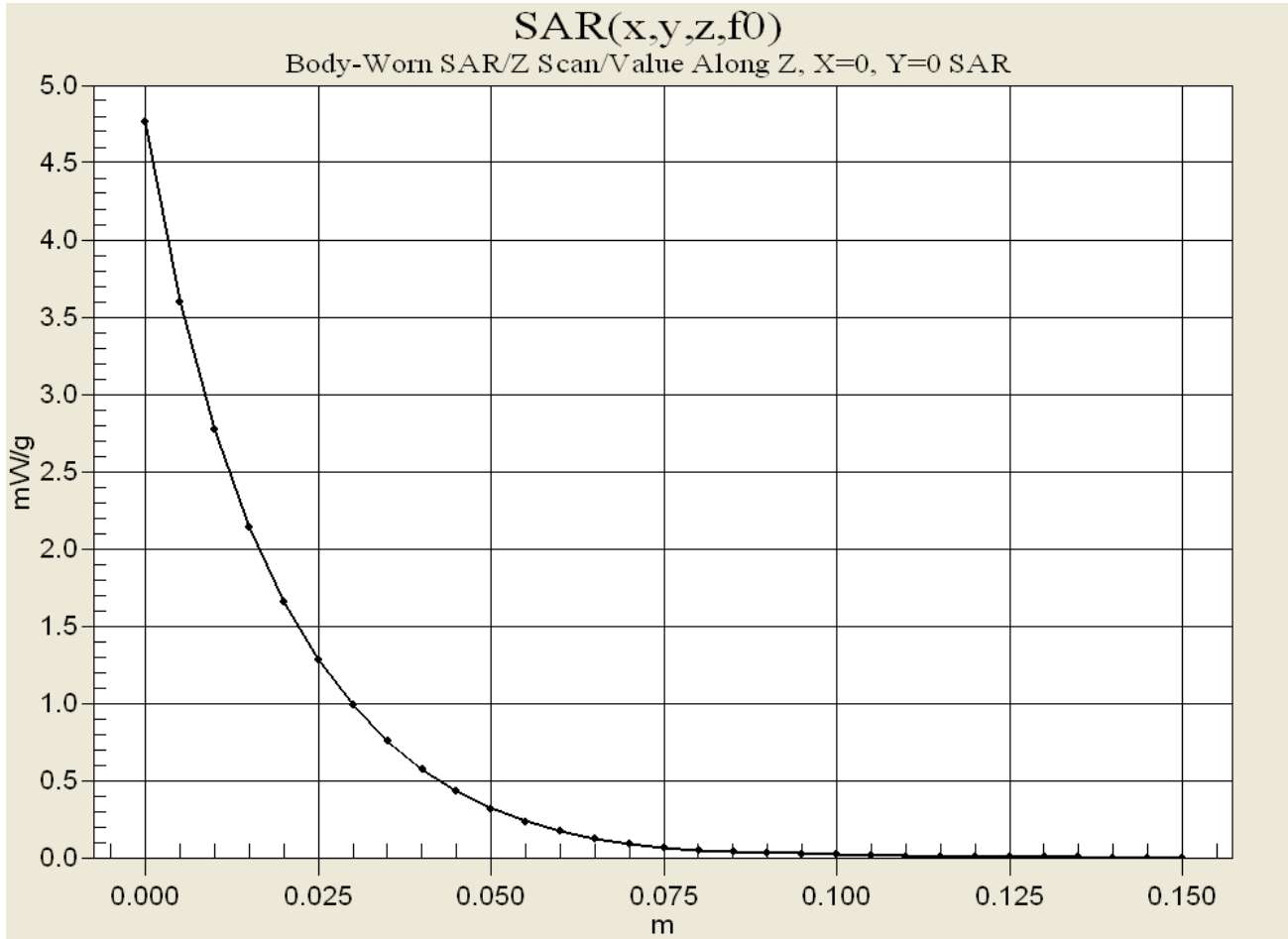

Date Tested: 12/18/03

DUT: Kenwood Model: TK-3202-1; Type: Portable UHF PTT Radio Transceiver; Serial: U12

Ambient Temp: 24.4 °C; Fluid Temp: 20.8 °C; Barometric Pressure: 98.2 kPa; Humidity: 35%

Communication System: FM UHF
 Frequency: 470 MHz; Duty Cycle: 1:1
 7.5V NiMH Battery Pack (P/N: KNB-29N)
 RF Output Power: 36.26 dBm (Conducted)
 Medium: M450 ($\sigma = 0.91$ mho/m, $\epsilon_r = 56.3$, $\rho = 1000$ kg/m³)

- Probe: ET3DV6 - SN1387; ConvF(7.7, 7.7, 7.7); Calibrated: 26/02/2003
- Sensor-Surface: 4mm (Mechanical Surface Detection)
- Electronics: DAE3 Sn370; Calibrated: 19/05/2003
- Phantom: Planar; Type: Plexiglas; Serial: 161
- Measurement SW: DASY4, V4.1 Build 47; Postprocessing SW: SEMCAD, V1.6 Build 116

Body-Worn - Whip Antenna - 1.1 cm Belt-Clip Separation Distance - Mid Channel/Area Scan (7x20x1):

Measurement grid: dx=15mm, dy=15mm

Body-Worn - Whip Antenna - 1.1 cm Belt-Clip Separation Distance - Mid Channel/Zoom Scan (7x7x7)/Cube 0:

Measurement grid: dx=5mm, dy=5mm, dz=5mm

Peak SAR (extrapolated) = 13.9 W/kg

SAR(1 g) = 8.65 mW/g; SAR(10 g) = 5.99 mW/g

Reference Value = 103.7 V/m

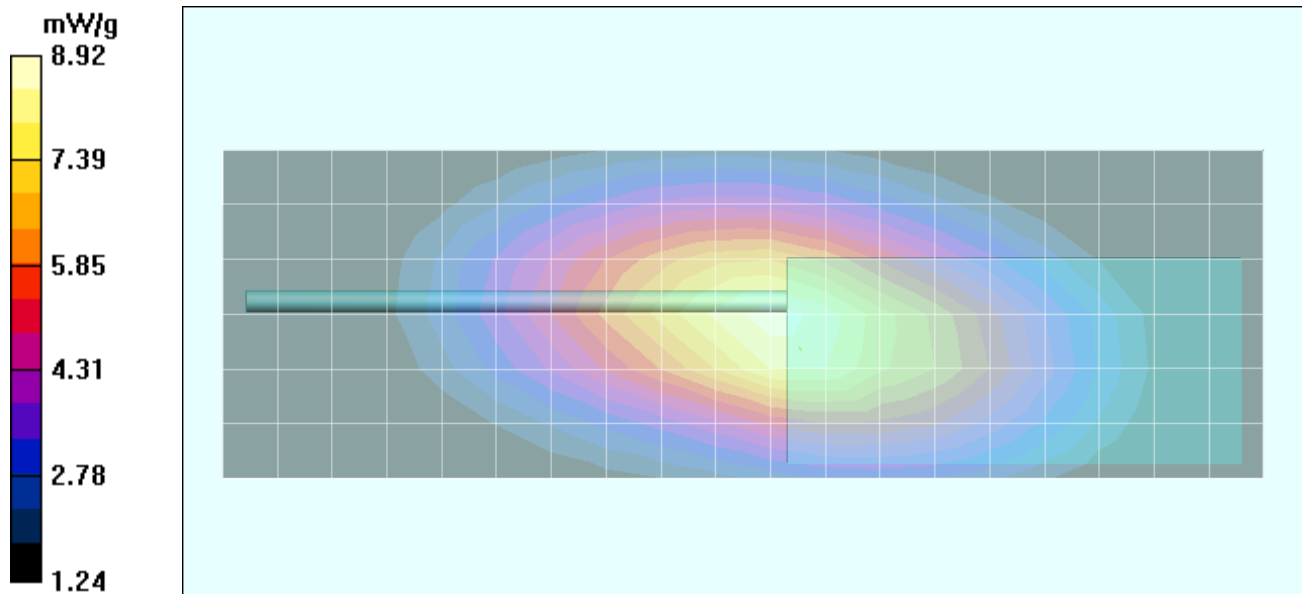

Date Tested: 12/18/03

DUT: Kenwood Model: TK-3202-1; Type: Portable UHF PTT Radio Transceiver; Serial: U12

Ambient Temp: 24.4 °C; Fluid Temp: 20.8 °C; Barometric Pressure: 98.2 kPa; Humidity: 35%

Communication System: FM UHF
 Frequency: 450 MHz; Duty Cycle: 1:1
 7.5V NiCd Battery Pack (P/N: KNB-30A)
 RF Output Power: 36.54 dBm (Conducted)
 Medium: M450 ($\sigma = 0.91$ mho/m, $\epsilon_r = 56.3$, $\rho = 1000$ kg/m³)

- Probe: ET3DV6 - SN1387; ConvF(7.7, 7.7, 7.7); Calibrated: 26/02/2003
- Sensor-Surface: 4mm (Mechanical Surface Detection)
- Electronics: DAE3 Sn370; Calibrated: 19/05/2003
- Phantom: Planar; Type: Plexiglas; Serial: 161
- Measurement SW: DASY4, V4.1 Build 47; Postprocessing SW: SEMCAD, V1.6 Build 116

Body-Worn - Whip Antenna - 1.1 cm Belt-Clip Separation Distance - Low Channel/Area Scan (7x20x1):
 Measurement grid: dx=15mm, dy=15mm

Body-Worn - Whip Antenna - 1.1 cm Belt-Clip Separation Distance - Low Channel/Zoom Scan (7x7x7)/Cube 0:
 Measurement grid: dx=5mm, dy=5mm, dz=5mm
 Peak SAR (extrapolated) = 10.9 W/kg
SAR(1 g) = 6.80 mW/g; SAR(10 g) = 4.74 mW/g
 Reference Value = 87.5 V/m

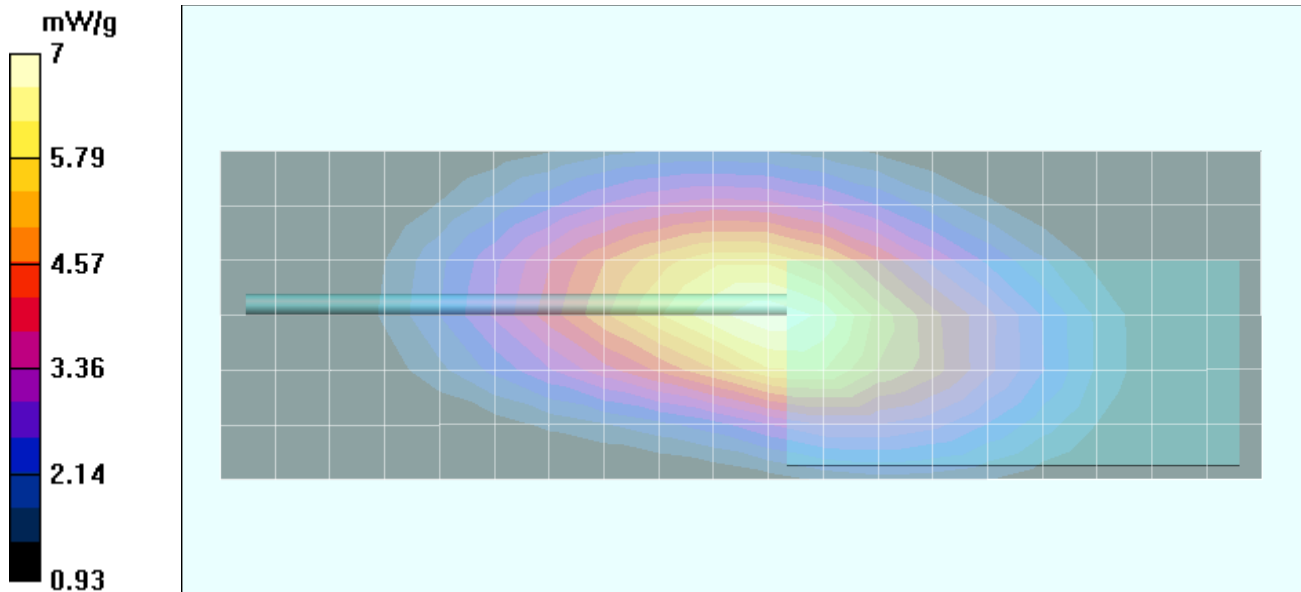

Date Tested: 12/18/03

DUT: Kenwood Model: TK-3202-1; Type: Portable UHF PTT Radio Transceiver; Serial: U12

Ambient Temp: 24.4 °C; Fluid Temp: 20.8 °C; Barometric Pressure: 98.2 kPa; Humidity: 35%

Communication System: FM UHF
 Frequency: 490 MHz; Duty Cycle: 1:1
 7.5V NiCd Battery Pack (P/N: KNB-30A)
 RF Output Power: 36.23 dBm (Conducted)
 Medium: M450 ($\sigma = 0.91$ mho/m, $\epsilon_r = 56.3$, $\rho = 1000$ kg/m³)

- Probe: ET3DV6 - SN1387; ConvF(7.7, 7.7, 7.7); Calibrated: 26/02/2003
- Sensor-Surface: 4mm (Mechanical Surface Detection)
- Electronics: DAE3 Sn370; Calibrated: 19/05/2003
- Phantom: Planar; Type: Plexiglas; Serial: 161
- Measurement SW: DASY4, V4.1 Build 47; Postprocessing SW: SEMCAD, V1.6 Build 116

Body-Worn - Whip Antenna - 1.1 cm Belt-Clip Separation Distance - High Channel/Area Scan (7x20x1):
 Measurement grid: dx=15mm, dy=15mm

Body-Worn - Whip Antenna - 1.1 cm Belt-Clip Separation Distance - High Channel/Zoom Scan (7x7x7)/Cube 0:
 Measurement grid: dx=5mm, dy=5mm, dz=5mm
 Peak SAR (extrapolated) = 11.8 W/kg
SAR(1 g) = 7.30 mW/g; SAR(10 g) = 5.07 mW/g
 Reference Value = 95.3 V/m

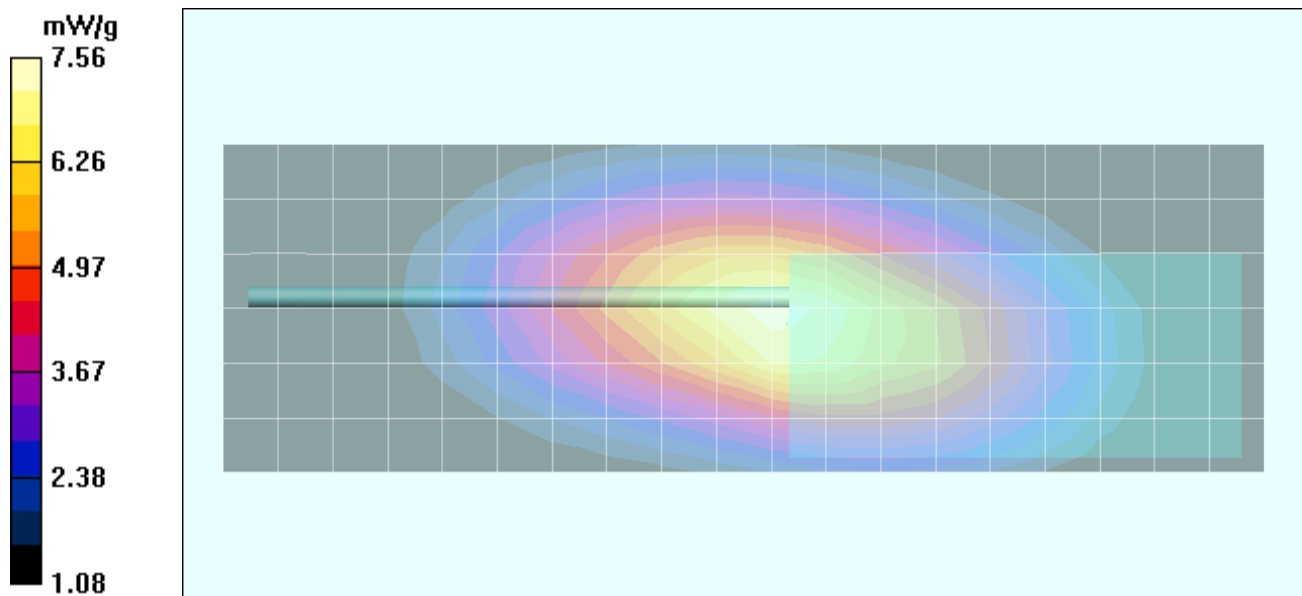

Test Report S/N:	120403-451ALH
Test Date(s):	December 17-18, 2003
Test Type:	FCC/IC SAR Evaluation

APPENDIX B - SYSTEM PERFORMANCE CHECK DATA

Date Tested: 12/17/03

DUT: Dipole 450 MHz; Model: D450V2; Type: System Performance Check; Serial: 136

Ambient Temp: 24.4 °C; Fluid Temp: 21.4 °C; Barometric Pressure: 98.1 kPa; Humidity: 33%

Communication System: CW
 Forward Conducted Power: 250mW
 Frequency: 450 MHz; Duty Cycle: 1:1
 Medium: HSL450 ($\sigma = 0.84$ mho/m, $\epsilon_r = 42.9$, $\rho = 1000$ kg/m³)

- Probe: ET3DV6 - SN1387; ConvF(7.5, 7.5, 7.5); Calibrated: 26/02/2003
- Sensor-Surface: 4mm (Mechanical Surface Detection)
- Electronics: DAE3 Sn370; Calibrated: 19/05/2003
- Phantom: Validation Planar; Type: Plexiglas; Serial: 137
- Measurement SW: DASY4, V4.1 Build 47; Postprocessing SW: SEMCAD, V1.6 Build 116

450 MHz System Performance Check/Area Scan (6x11x1):
 Measurement grid: dx=15mm, dy=15mm

450 MHz System Performance Check/Zoom Scan (7x7x7)/Cube 0:
 Measurement grid: dx=5mm, dy=5mm, dz=5mm
 Peak SAR (extrapolated) = 2.26 W/kg
SAR(1 g) = 1.29 mW/g; SAR(10 g) = 0.82 mW/g
 Reference Value = 39.9 V/m
 Power Drift = -0.08 dB

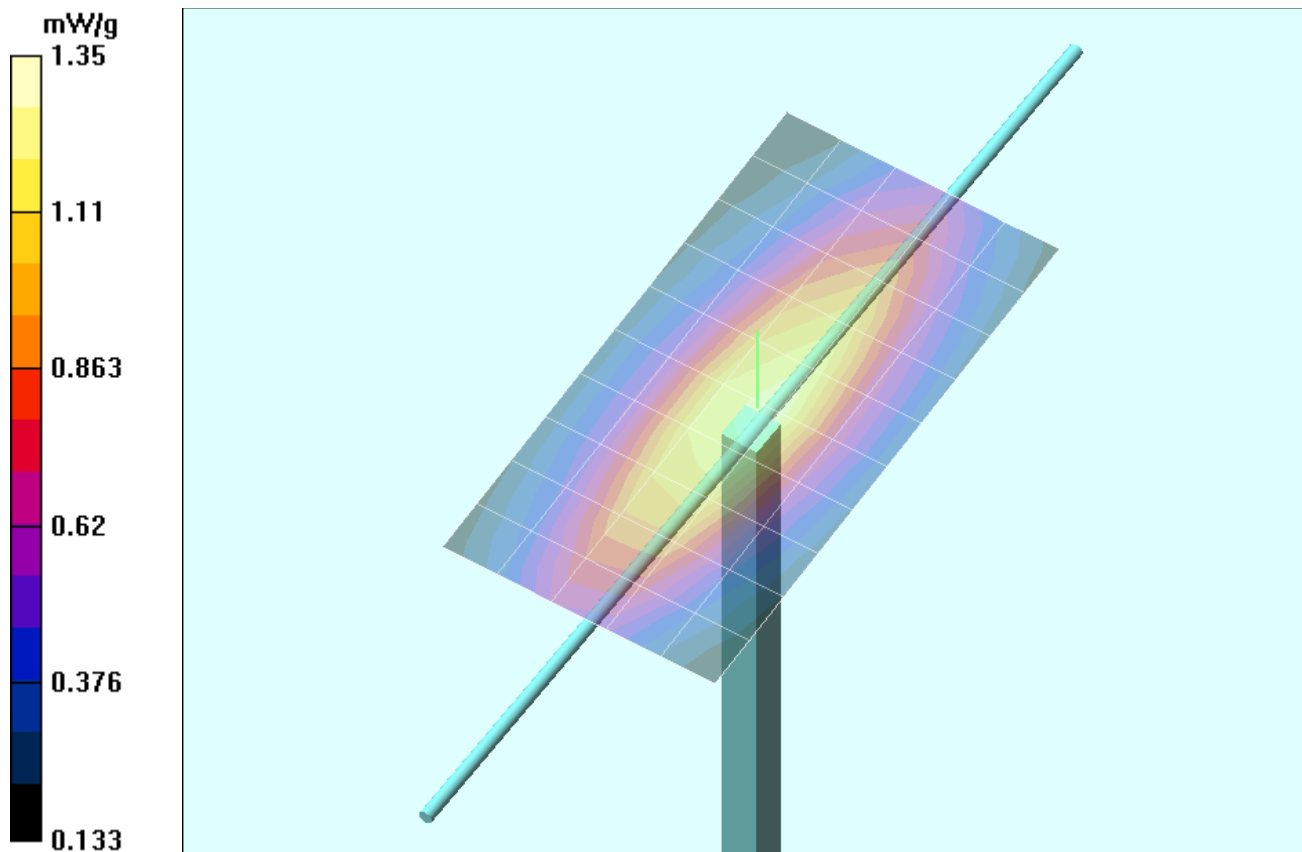

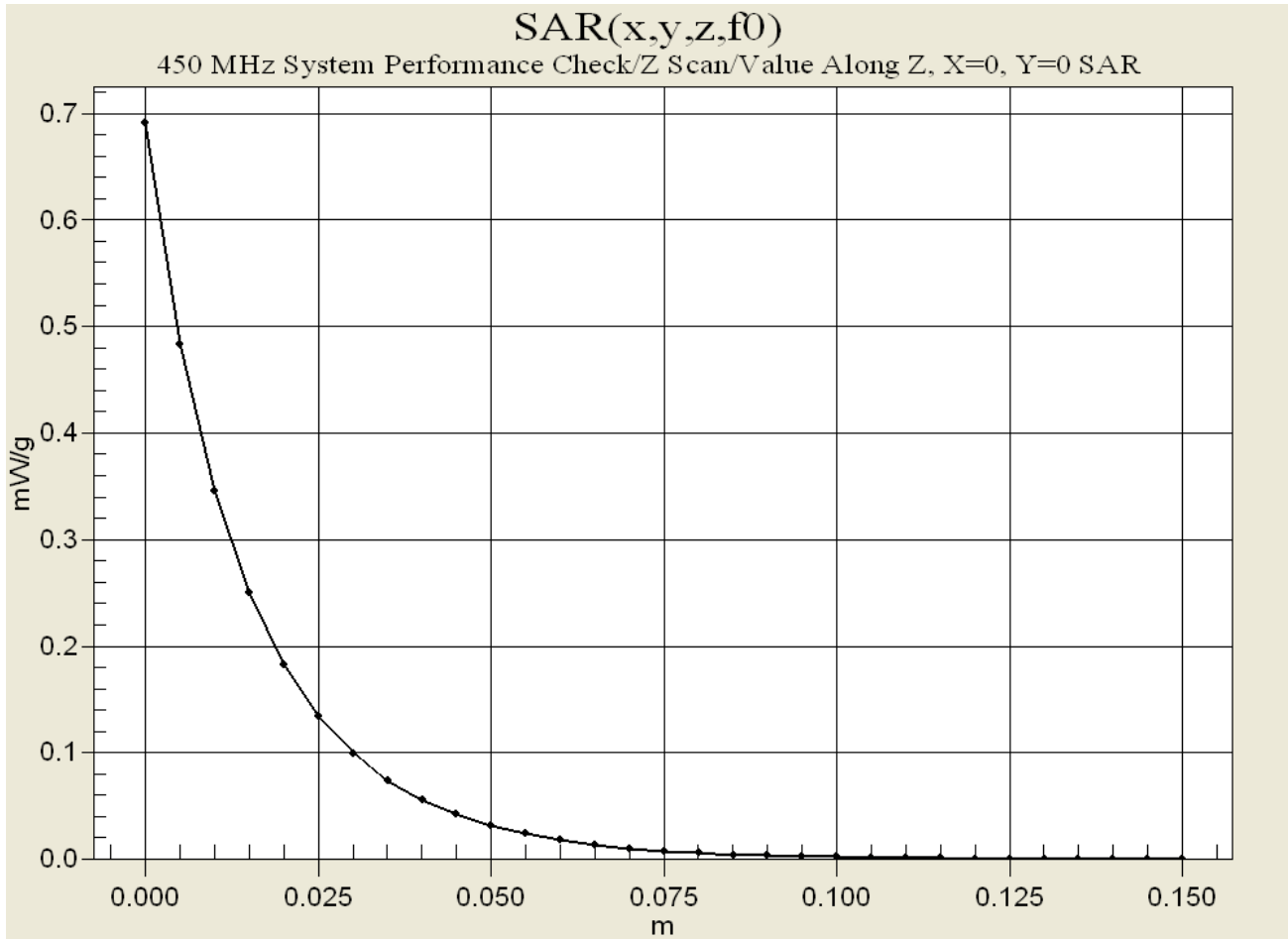

Date Tested: 12/18/03

DUT: Dipole 450 MHz; Model: D450V2; Type: System Performance Check; Serial: 136

Ambient Temp: 24.0 °C; Fluid Temp: 20.9 °C; Barometric Pressure: 98.2 kPa; Humidity: 35%

Communication System: CW
 Forward Conducted Power: 250mW
 Frequency: 450 MHz; Duty Cycle: 1:1
 Medium: HSL450 ($\sigma = 0.85 \text{ mho/m}$, $\epsilon_r = 43.2$, $\rho = 1000 \text{ kg/m}^3$)

- Probe: ET3DV6 - SN1387; ConvF(7.5, 7.5, 7.5); Calibrated: 26/02/2003
- Sensor-Surface: 4mm (Mechanical Surface Detection)
- Electronics: DAE3 Sn370; Calibrated: 19/05/2003
- Phantom: Validation Planar; Type: Plexiglas; Serial: 137
- Measurement SW: DASY4, V4.1 Build 47; Postprocessing SW: SEMCAD, V1.6 Build 116

450 MHz System Performance Check/Area Scan (6x11x1):

Measurement grid: dx=15mm, dy=15mm

450 MHz System Performance Check/Zoom Scan (7x7x7)/Cube 0:

Measurement grid: dx=5mm, dy=5mm, dz=5mm

Peak SAR (extrapolated) = 2.3 W/kg

SAR(1 g) = 1.31 mW/g; SAR(10 g) = 0.833 mW/g

Reference Value = 40.2 V/m

Power Drift = -0.06 dB

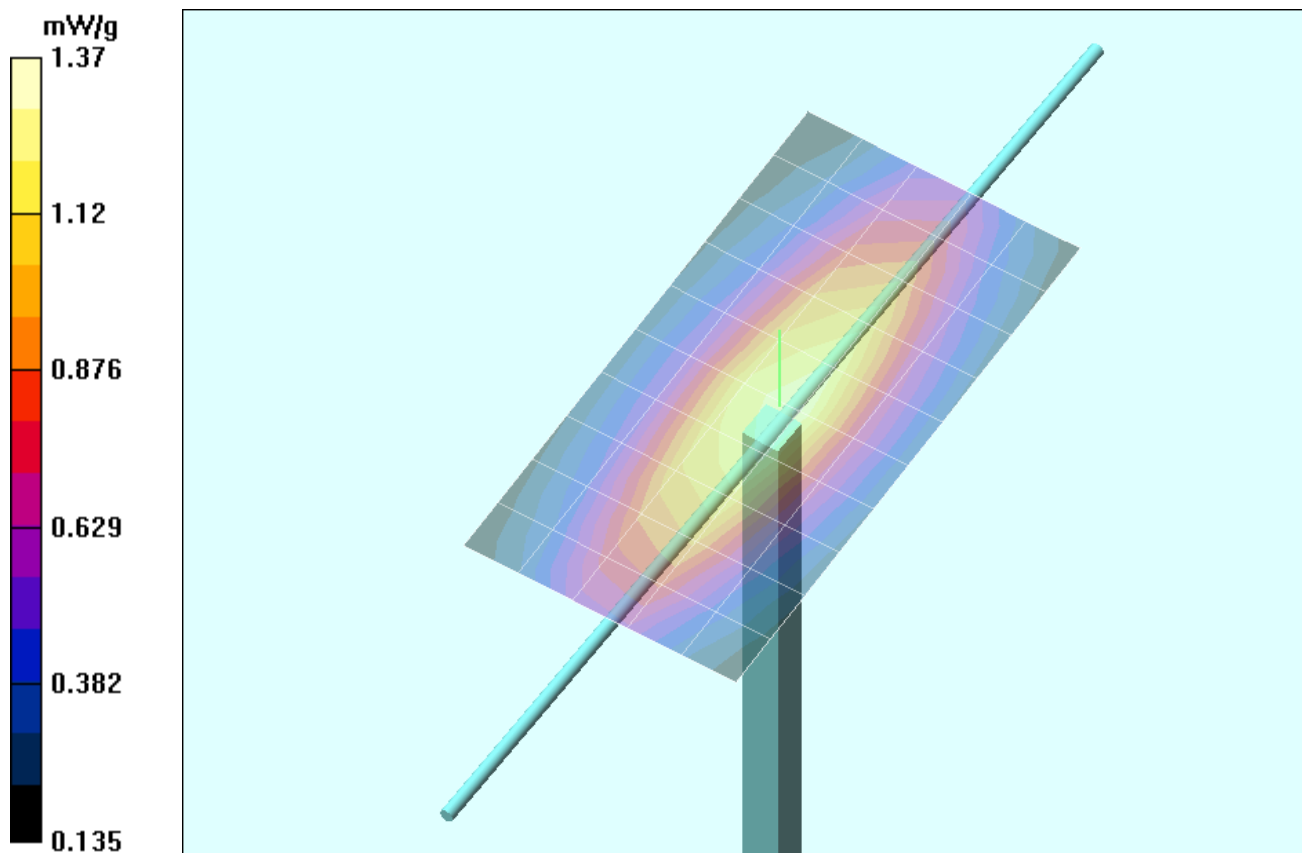

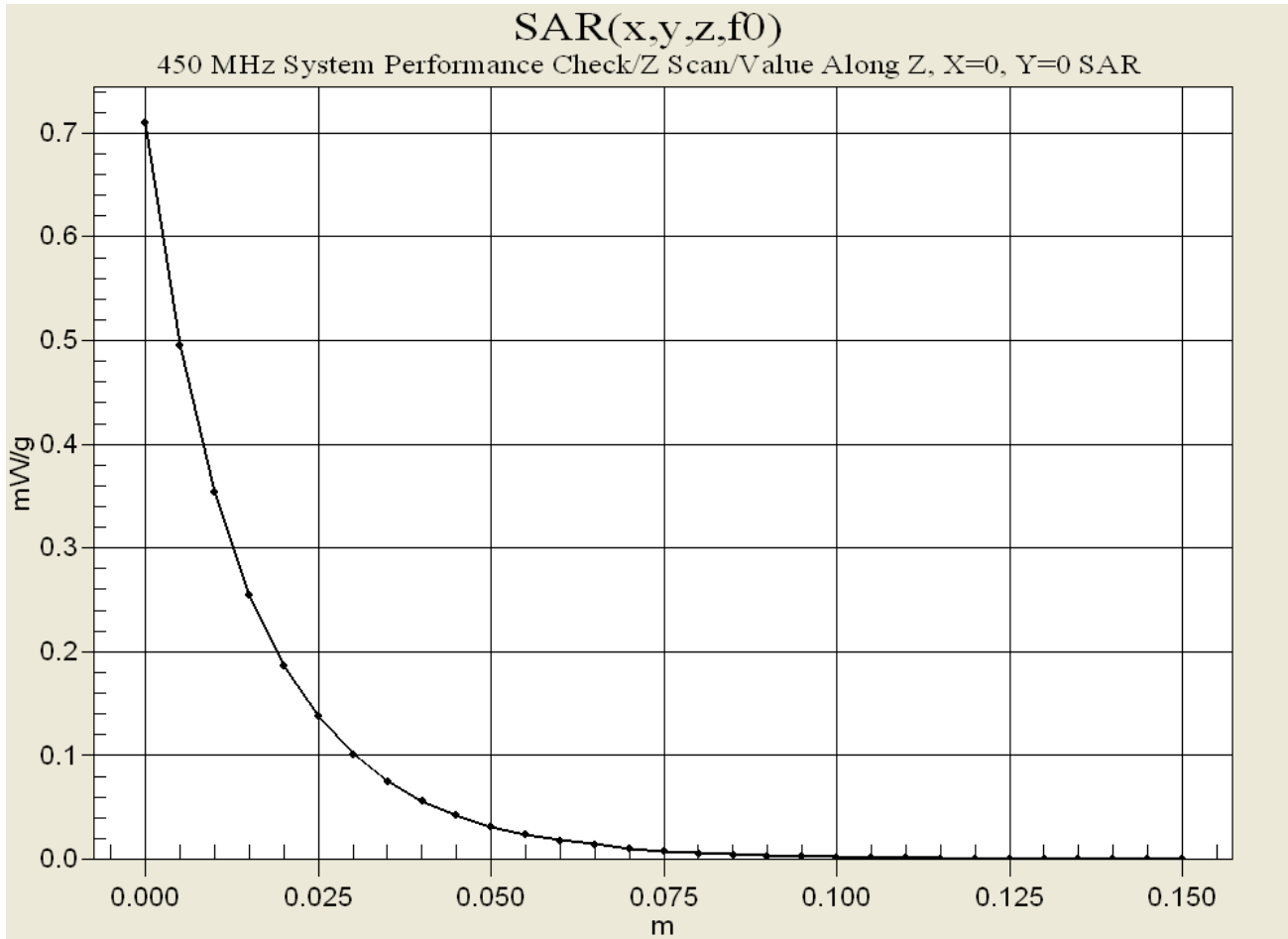

Test Report S/N:	120403-451ALH
Test Date(s):	December 17-18, 2003
Test Type:	FCC/IC SAR Evaluation

APPENDIX C - SYSTEM VALIDATION

450MHz SYSTEM VALIDATION DIPOLE

Type:

450MHz Validation Dipole

Serial Number:

136

Place of Calibration:

Celltech Labs Inc.

Date of Calibration:

November 4, 2003

Celltech Labs Inc. hereby certifies that this device has been calibrated on the date indicated above.

Calibrated by:

Spencer Watson

Approved by:

Russell W. Pope

1. Dipole Construction & Electrical Characteristics

The validation dipole was constructed in accordance with the IEEE Std “Recommended Practice for Determining the Spatial-Peak Specific Absorption Rate (SAR) in the Human Body Due to Wireless Communications Devices: Experimental Techniques”. The electrical properties were measured using an HP 8753E Network Analyzer. The network analyzer was calibrated to the validation dipole N-type connector feed point using an HP85032E Type N calibration kit. The dipole was placed parallel to a planar phantom at a separation distance of 15.0mm from the simulating fluid using a loss-less dielectric spacer. The measured input impedance is:

Feed point impedance at 450MHz $\text{Re}\{Z\} = 49.982\Omega$

$\text{Im}\{Z\} = 7.2324\Omega$

Return Loss at 450MHz

-22.597dB

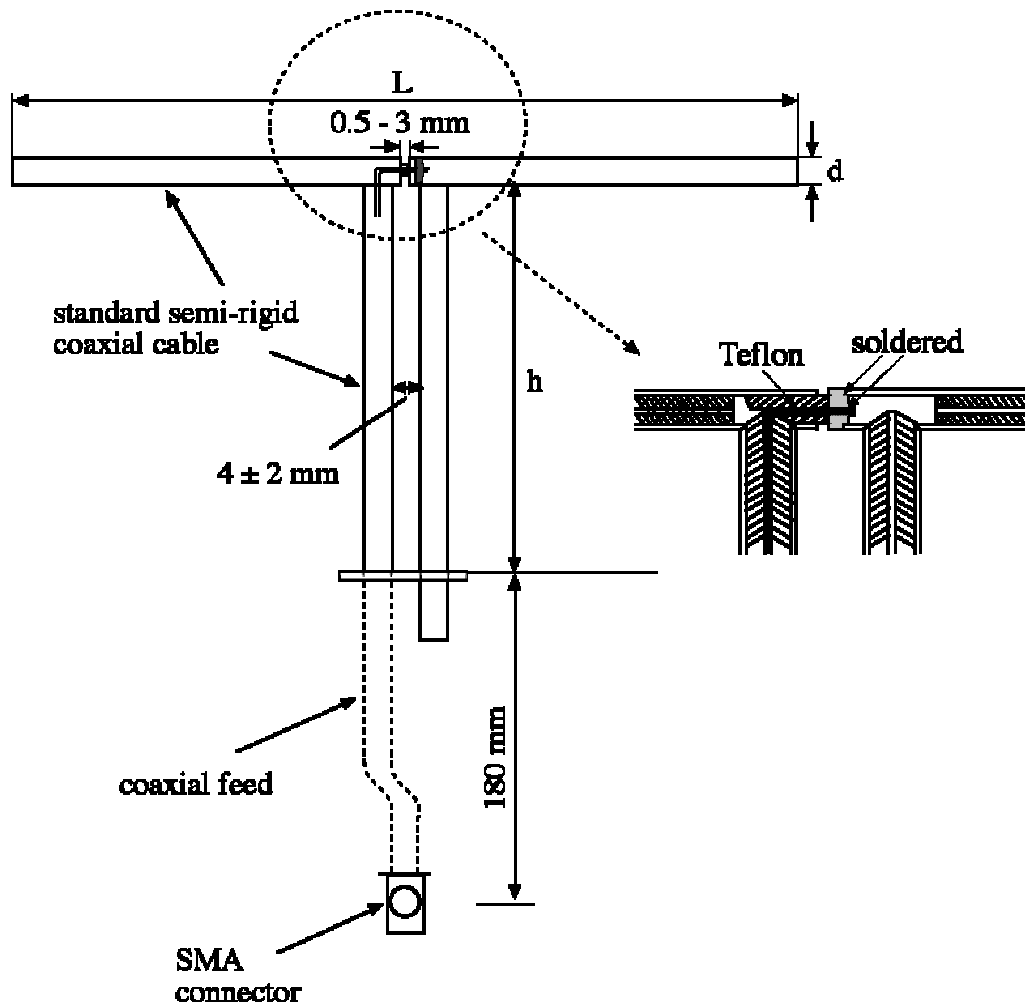

CH1 S11 1 U FS 1: 49.982 Ω 7.2324 Ω 2.5579 nH 4 Nov 2003 12:04:21 450.000 000 MHz

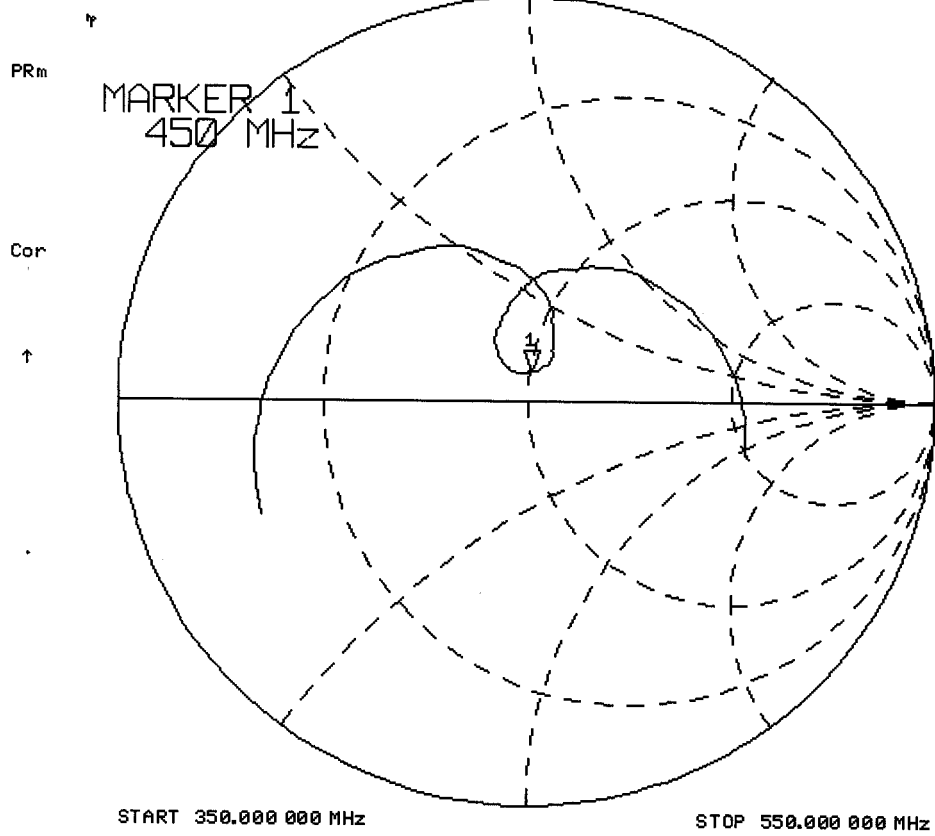

[CH1] S11 LOG 10 dB/REF 0 dB 4 Nov 2003 12:06:24
1:-22.597 dB 450.000 000 MHz

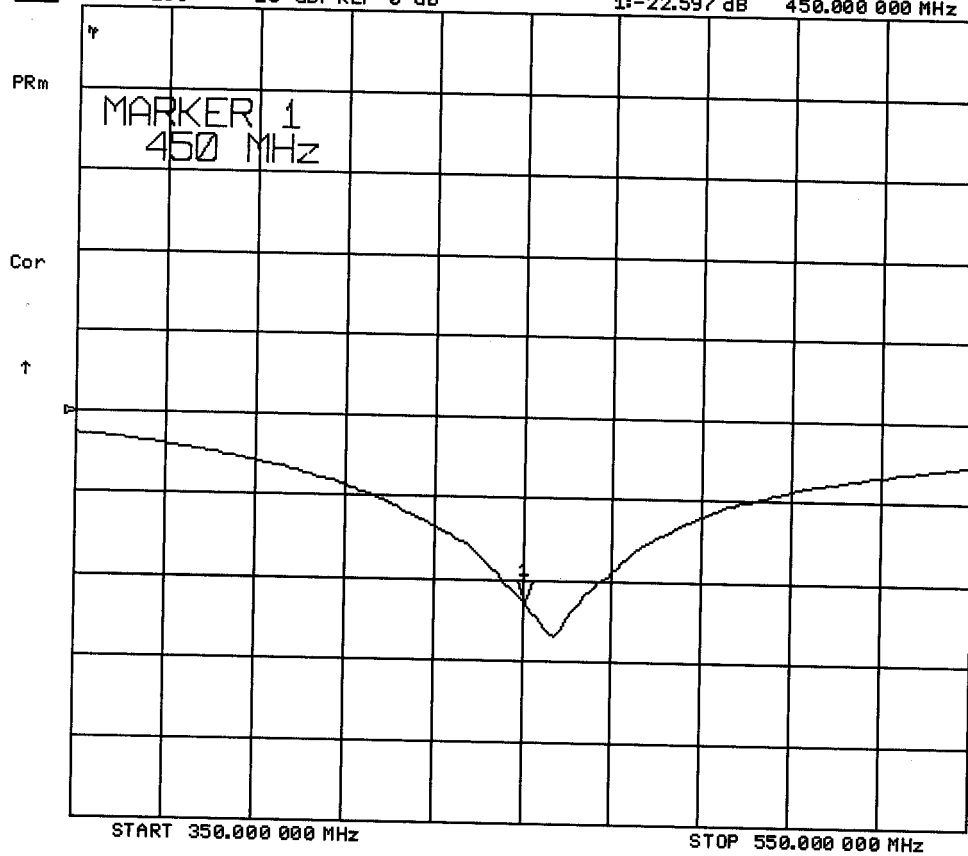

2. Validation Dipole Dimensions

Frequency (MHz)	L (mm)	h (mm)	d (mm)
300	420.0	250.0	6.2
450	288.0	167.0	6.2
835	161.0	89.8	3.6
900	149.0	83.3	3.6
1450	89.1	51.7	3.6
1800	72.0	41.7	3.6
1900	68.0	39.5	3.6
2000	64.5	37.5	3.6
2450	51.8	30.6	3.6
3000	41.5	25.0	3.6

3. Validation Phantom

The validation phantom was constructed using relatively low-loss tangent Plexiglas material. The inner dimensions of the phantom are as follows:

Length: 83.5 cm
 Width: 36.9 cm
 Height: 21.8 cm

The bottom section of the validation phantom is constructed of 6.2 ± 0.1 mm Plexiglas.

4. Dimensions of Plexiglas Planar Phantom

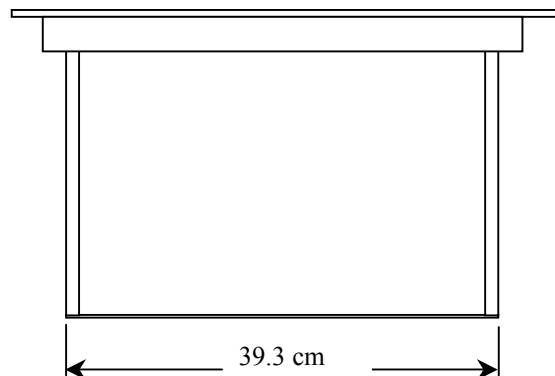
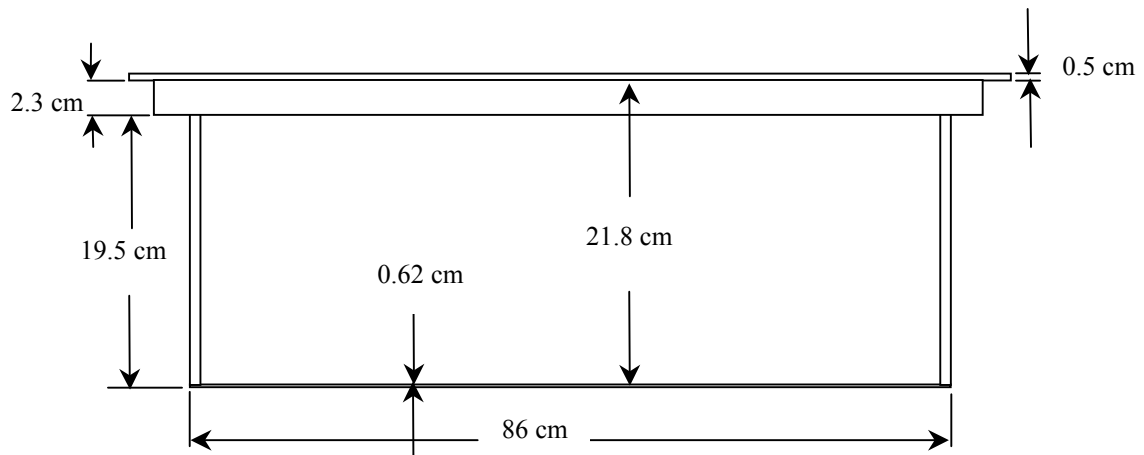
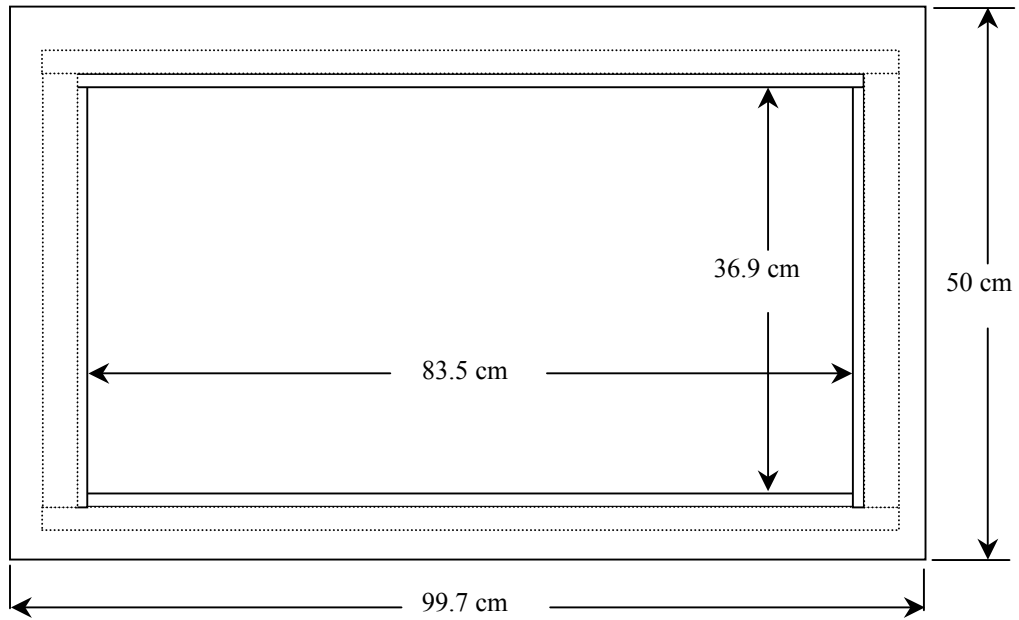

5. 450MHz System Validation Setup



450MHz System Validation Setup

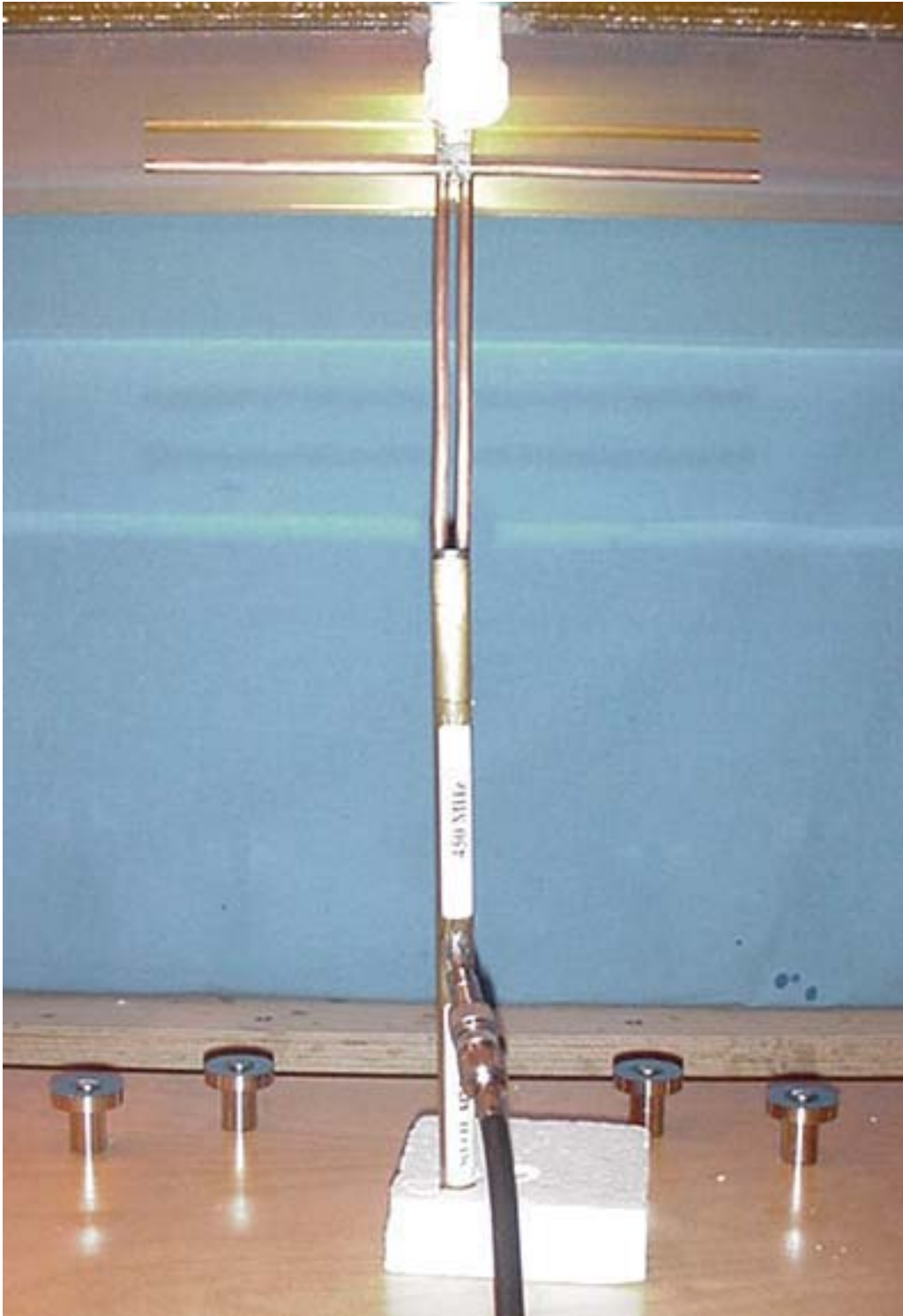

6. Measurement Conditions

The planar phantom was filled with brain simulating tissue having the following parameters at 450MHz:

Relative Permittivity: 43.7
 Conductivity: 0.88 mho/m
 Fluid Temperature: 22.0 °C
 Fluid Depth: ≥ 15.0 cm

Environmental Conditions:

Ambient Temperature: 22.1 °C
 Humidity: 49 %
 Barometric Pressure: 102.8 kPa

The 450MHz simulated brain tissue mixture consists of the following ingredients:

Ingredient	Percentage by weight
Water	38.56%
Sugar	56.32%
Salt	3.95%
HEC	0.98%
Dowicil 75	0.19%
450MHz Target Dielectric Parameters at 22 °C	$\epsilon_r = 43.5$ $\sigma = 0.87 \text{ S/m}$

7. SAR Measurement

The SAR measurement was performed with the E-field probe in mechanical detection mode only. The setup and determination of the forward power into the dipole was performed using the following procedures.

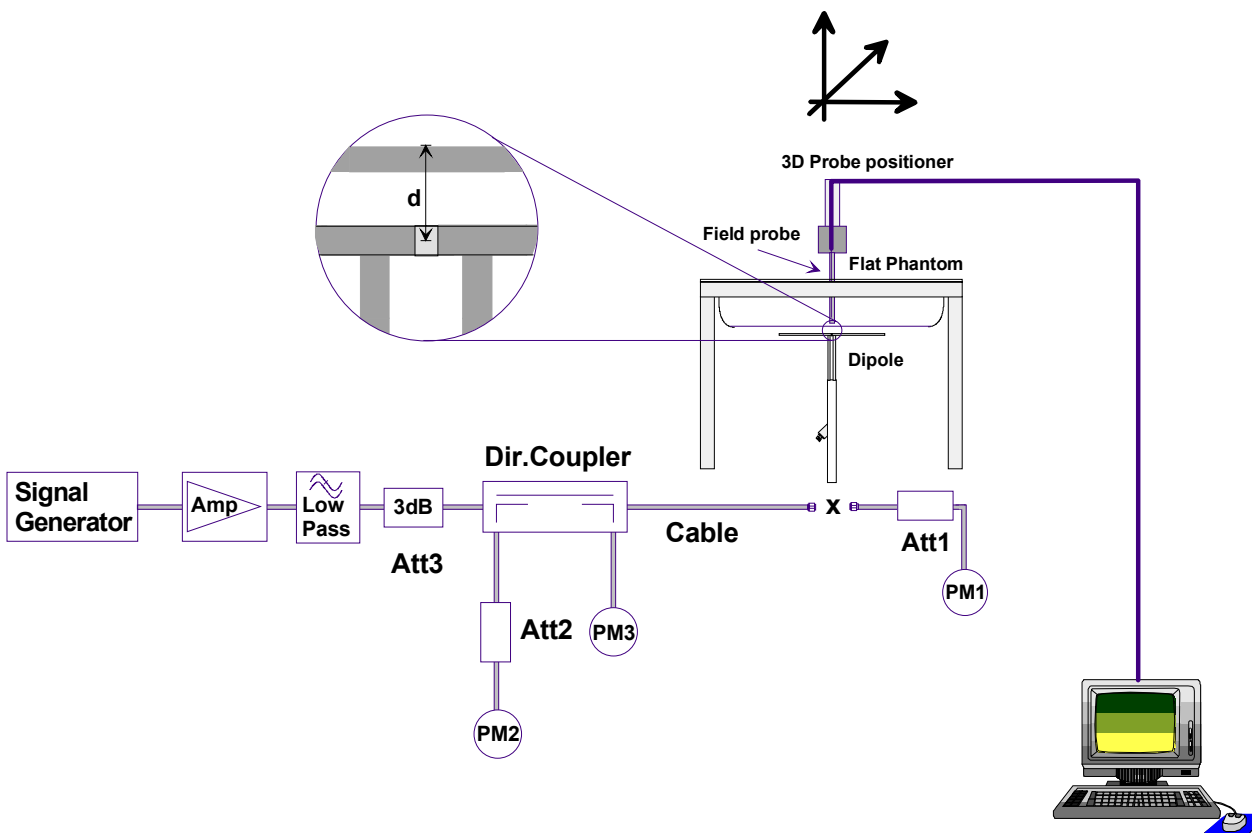

First the power meter PM1 (including attenuator Att1) is connected to the cable to measure the forward power at the location of the dipole connector (X). The signal generator is adjusted for the desired forward power at the dipole connector (taking into account the attenuation of Att1) as read by power meter PM2. After connecting the cable to the dipole, the signal generator is readjusted for the same reading at power meter PM2. If the signal generator does not allow adjustment in 0.01dB steps, the remaining difference at PM2 must be taken into consideration. PM3 records the reflected power from the dipole to ensure that the value is not changed from the previous value. The reflected power should be 20dB below the forward power.

8. Validation Dipole SAR Test Results

Ten SAR measurements were performed in order to achieve repeatability and to establish an average target value.

Validation Measurement	SAR @ 0.25W Input averaged over 1g	SAR @ 1W Input averaged over 1g	SAR @ 0.25W Input averaged over 10g	SAR @ 1W Input averaged over 10g	Peak SAR @ 0.25W Input
Test 1	1.29	5.16	0.810	3.24	2.28
Test 2	1.31	5.24	0.827	3.31	2.31
Test 3	1.30	5.20	0.823	3.29	2.29
Test 4	1.30	5.20	0.822	3.29	2.29
Test 5	1.29	5.16	0.819	3.28	2.28
Test 6	1.30	5.20	0.826	3.30	2.28
Test 7	1.31	5.24	0.826	3.30	2.30
Test 8	1.31	5.24	0.829	3.32	2.30
Test 9	1.30	5.20	0.822	3.29	2.28
Test 10	1.31	5.24	0.822	3.29	2.33
Average Value	1.30	5.21	0.823	3.29	2.29

The results have been normalized to 1W (forward power) into the dipole.

IEEE Target over 1cm³ (1g) of tissue: 1.23 mW/g (+/- 10%)

Averaged over 1cm (1g) of tissue: 5.21 mW/g

Averaged over 10cm (10g) of tissue: 3.29 mW/g

Test Date: 11/04/03

DUT: Dipole 450MHz; Model: D450V2; Type: System Performance Check; Serial: 136

Ambient Temp: 22.1°C; Fluid Temp: 22.0°C; Barometric Pressure: 102.8 kPa; Humidity: 49%

Communication System: CW
Forward Conducted Power: 250 mW
Frequency: 450 MHz; Duty Cycle: 1:1
Medium: HSL450 ($\sigma = 0.88$ mho/m, $\epsilon_r = 43.7$, $\rho = 1000$ kg/m³)

- Probe: ET3DV6 - SN1387; ConvF(7.5, 7.5, 7.5); Calibrated: 26/02/2003
- Sensor-Surface: 4mm (Mechanical Surface Detection)
- Electronics: DAE3 Sn370; Calibrated: 19/05/2003
- Phantom: Validation Planar; Type: Plexiglas; Serial: 137
- Measurement SW: DASY4, V4.1 Build 47; Postprocessing SW: SEMCAD, V1.6 Build 116

450 MHz Validation/Area Scan (6x11x1): Measurement grid: dx=15mm, dy=15mm

Reference Value = 39 V/m

Power Drift = -0.08 dB

Maximum value of SAR = 1.3 mW/g

450 MHz Validation/Zoom Scan 8 (7x7x7)/Cube 0: Measurement grid: dx=5mm, dy=5mm, dz=5mm

Peak SAR (extrapolated) = 2.28 W/kg

SAR(1 g) = 1.3 mW/g; SAR(10 g) = 0.822 mW/g

Reference Value = 39 V/m

Power Drift = 0.08 dB

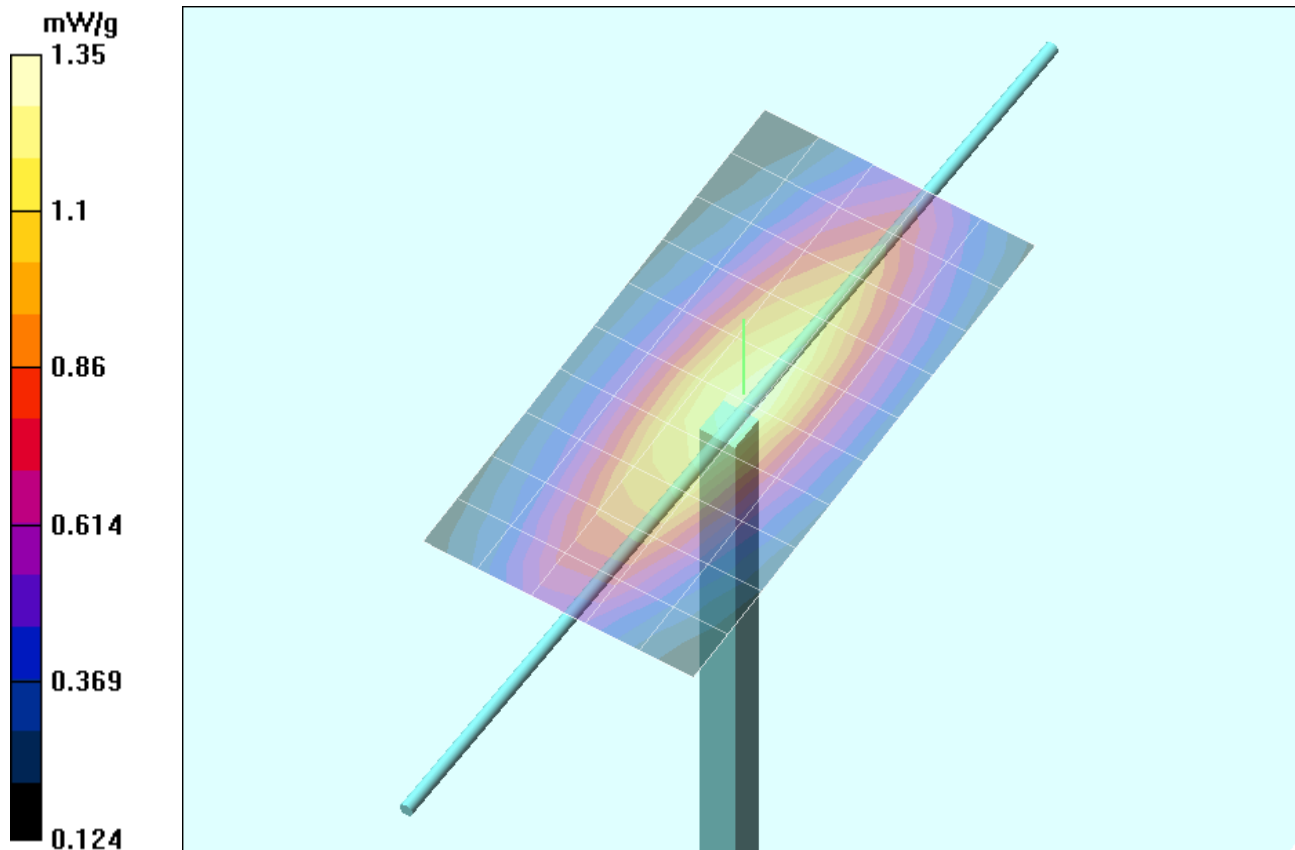

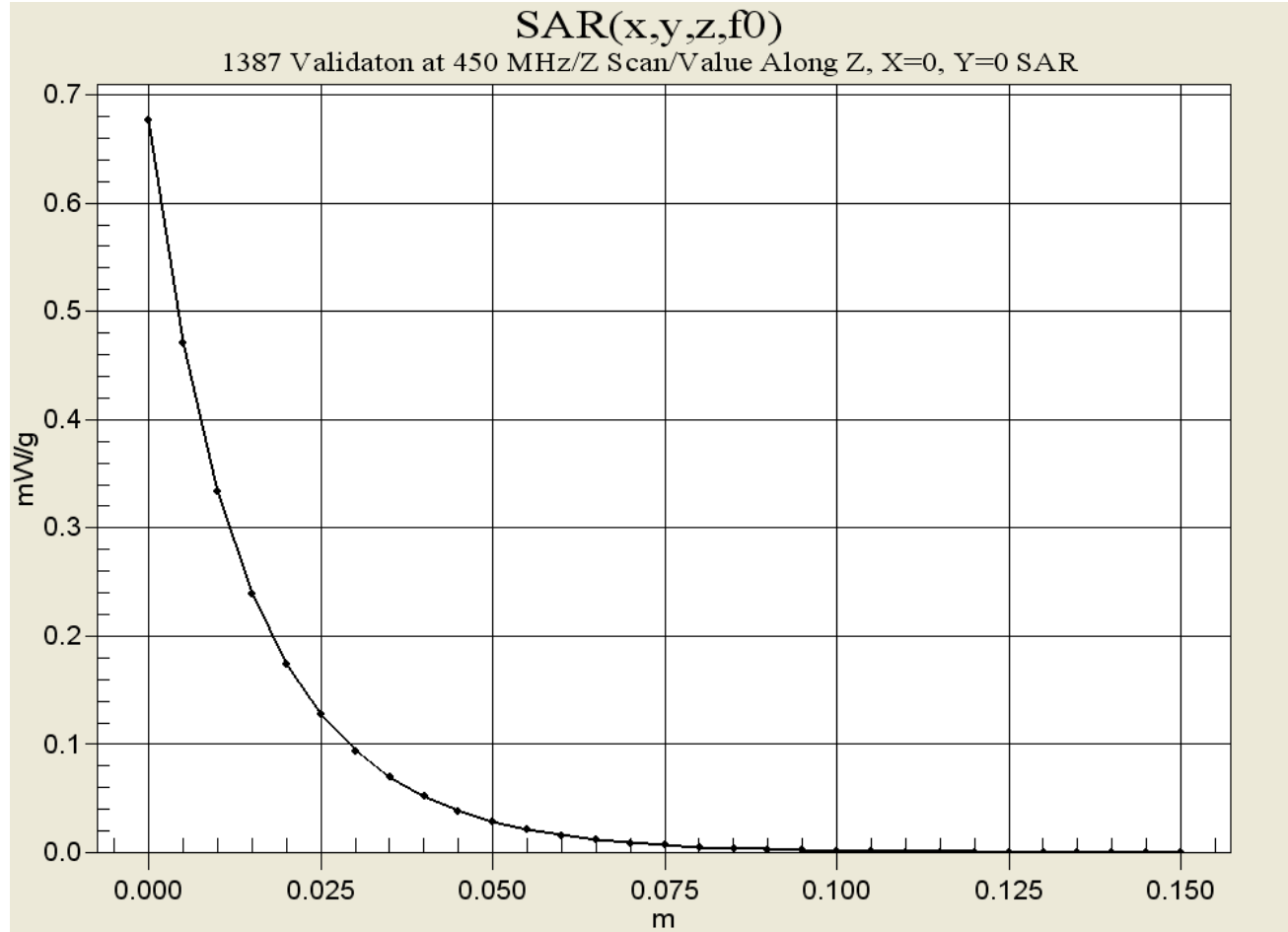

450MHz System Validation

Measured Fluid Dielectric Parameters (Brain)

November 04, 2003

Frequency	ϵ'	ϵ''
350.000000 MHz	46.2660	40.8224
360.000000 MHz	45.9937	40.0986
370.000000 MHz	45.7556	39.4543
380.000000 MHz	45.5625	38.7387
390.000000 MHz	45.2820	38.1140
400.000000 MHz	45.0146	37.4981
410.000000 MHz	44.7508	36.9734
420.000000 MHz	44.5046	36.4917
430.000000 MHz	44.2494	35.9460
440.000000 MHz	43.9621	35.5647
450.000000 MHz	43.7384	35.2106
460.000000 MHz	43.5513	34.7930
470.000000 MHz	43.2846	34.3970
480.000000 MHz	43.0654	33.9576
490.000000 MHz	42.8566	33.6391
500.000000 MHz	42.6744	33.2270
510.000000 MHz	42.5036	32.8459
520.000000 MHz	42.3492	32.5261
530.000000 MHz	42.1783	32.1727
540.000000 MHz	41.9985	31.7385
550.000000 MHz	41.8097	31.4862

Test Report S/N:	120403-451ALH
Test Date(s):	December 17-18, 2003
Test Type:	FCC/IC SAR Evaluation

APPENDIX D - PROBE CALIBRATION

Client **Celltech Labs**

CALIBRATION CERTIFICATE

Object(s) **ET3DV6 - SN: 1387**

Calibration procedure(s) **QA CAL-01.v2
 Calibration procedure for dosimetric E-field probes**

Calibration date: **February 26, 2003**



Condition of the calibrated item **In Tolerance (according to the specific calibration document)**

This calibration statement documents traceability of M&TE used in the calibration procedures and conformity of the procedures with the ISO/IEC 17025 international standard.

All calibrations have been conducted in the closed laboratory facility: environment temperature 22 +/- 2 degrees Celsius and humidity < 75%.

Calibration Equipment used (M&TE critical for calibration)

Model Type	ID #	Cal Date	Scheduled Calibration
RF generator HP 8684C	US3642U01700	4-Aug-99 (in house check Aug-02)	In house check: Aug-05
Power sensor E4412A	MY41495277	8-Mar-02	Mar-03
Power sensor HP 8481A	MY41092180	18-Sep-02	Sep-03
Power meter EPM E4419B	GB41293874	13-Sep-02	Sep-03
Network Analyzer HP 8753E	US38432426	3-May-00	In house check: May 03
Fluke Process Calibrator Type 702	SN: 6295803	3-Sep-01	Sep-03

	Name	Function	Signature
Calibrated by:	Nico Vetterli	Technician	
Approved by:	Katja Pokovic	Laboratory Director	

Date issued: February 26, 2003

This calibration certificate is issued as an intermediate solution until the accreditation process (based on ISO/IEC 17025 International Standard) for Calibration Laboratory of Schmid & Partner Engineering AG is completed.

Probe ET3DV6

SN:1387

Manufactured:	September 21, 1999
Last calibration:	February 22, 2002
Recalibrated:	February 26, 2003

Calibrated for DASY Systems

(Note: non-compatible with DASY2 system!)

DASY - Parameters of Probe: ET3DV6 SN:1387

Sensitivity in Free Space

NormX	1.55 $\mu\text{V}/(\text{V}/\text{m})^2$
NormY	1.65 $\mu\text{V}/(\text{V}/\text{m})^2$
NormZ	1.64 $\mu\text{V}/(\text{V}/\text{m})^2$

Diode Compression

DCP X	92	mV
DCP Y	92	mV
DCP Z	92	mV

Sensitivity in Tissue Simulating Liquid

Head	900 MHz	$\epsilon_r = 41.5 \pm 5\%$	$\sigma = 0.97 \pm 5\% \text{ mho/m}$
Head	835 MHz	$\epsilon_r = 41.5 \pm 5\%$	$\sigma = 0.90 \pm 5\% \text{ mho/m}$
ConvF X	6.6 $\pm 9.5\%$ (k=2)	Boundary effect:	
ConvF Y	6.6 $\pm 9.5\%$ (k=2)	Alpha	0.37
ConvF Z	6.6 $\pm 9.5\%$ (k=2)	Depth	2.61
Head	1800 MHz	$\epsilon_r = 40.0 \pm 5\%$	$\sigma = 1.40 \pm 5\% \text{ mho/m}$
Head	1900 MHz	$\epsilon_r = 40.0 \pm 5\%$	$\sigma = 1.40 \pm 5\% \text{ mho/m}$
ConvF X	5.2 $\pm 9.5\%$ (k=2)	Boundary effect:	
ConvF Y	5.2 $\pm 9.5\%$ (k=2)	Alpha	0.50
ConvF Z	5.2 $\pm 9.5\%$ (k=2)	Depth	2.73

Boundary Effect

Head	900 MHz	Typical SAR gradient: 5 % per mm	
Probe Tip to Boundary		1 mm	2 mm
SAR _{be} [%]	Without Correction Algorithm	10.2	5.9
SAR _{be} [%]	With Correction Algorithm	0.4	0.6
Head	1800 MHz	Typical SAR gradient: 10 % per mm	
Probe Tip to Boundary		1 mm	2 mm
SAR _{be} [%]	Without Correction Algorithm	14.6	9.8
SAR _{be} [%]	With Correction Algorithm	0.2	0.0

Sensor Offset

Probe Tip to Sensor Center	2.7	mm
Optical Surface Detection	1.4 \pm 0.2	mm

Receiving Pattern (ϕ), $\theta = 0^\circ$

f = 30 MHz, TEM cell ifi110

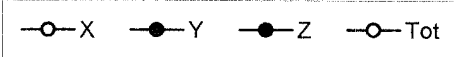
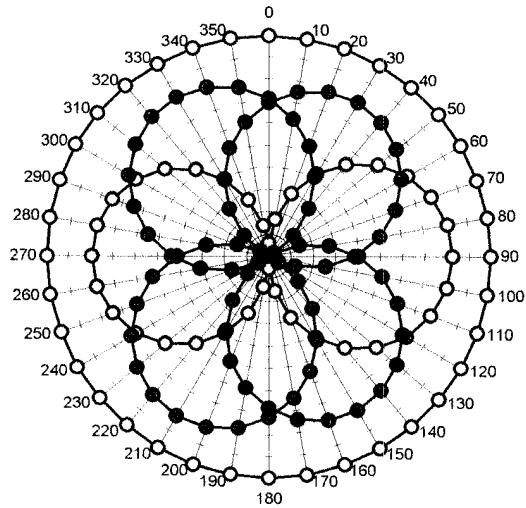

f = 100 MHz, TEM cell ifi110

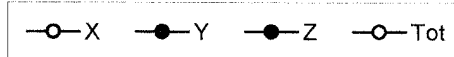
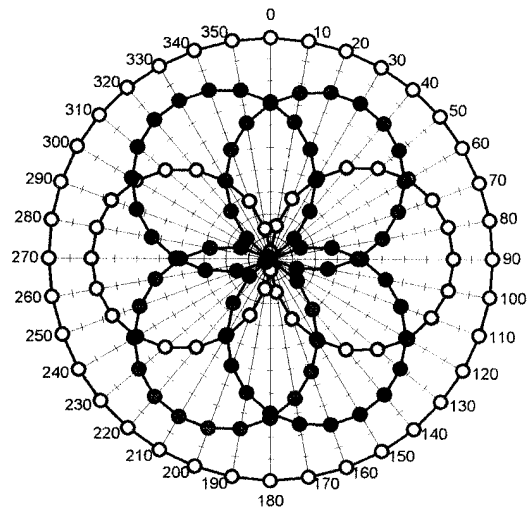

f = 300 MHz, TEM cell ifi110

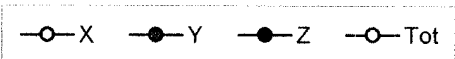
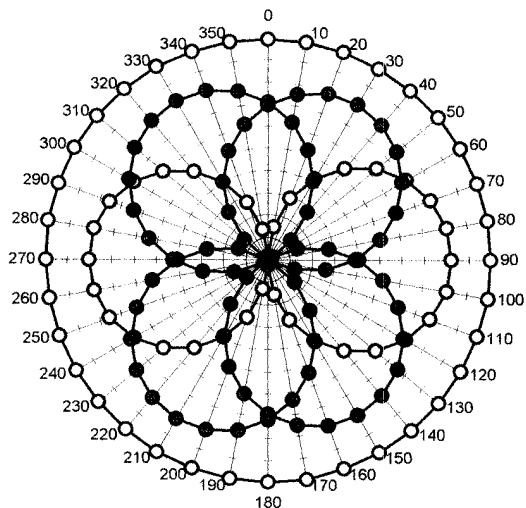

f = 900 MHz, TEM cell ifi110

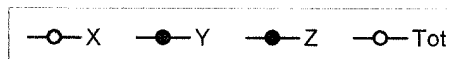
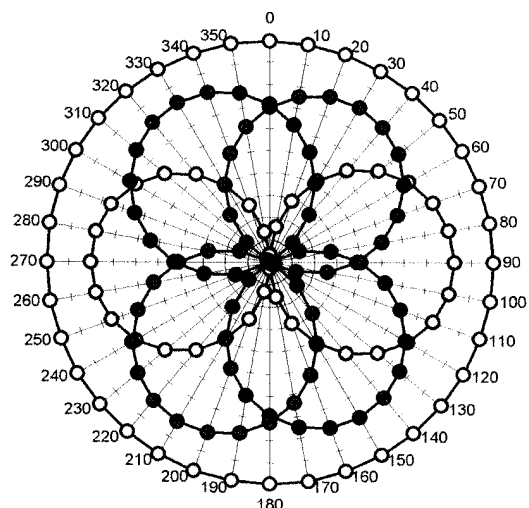

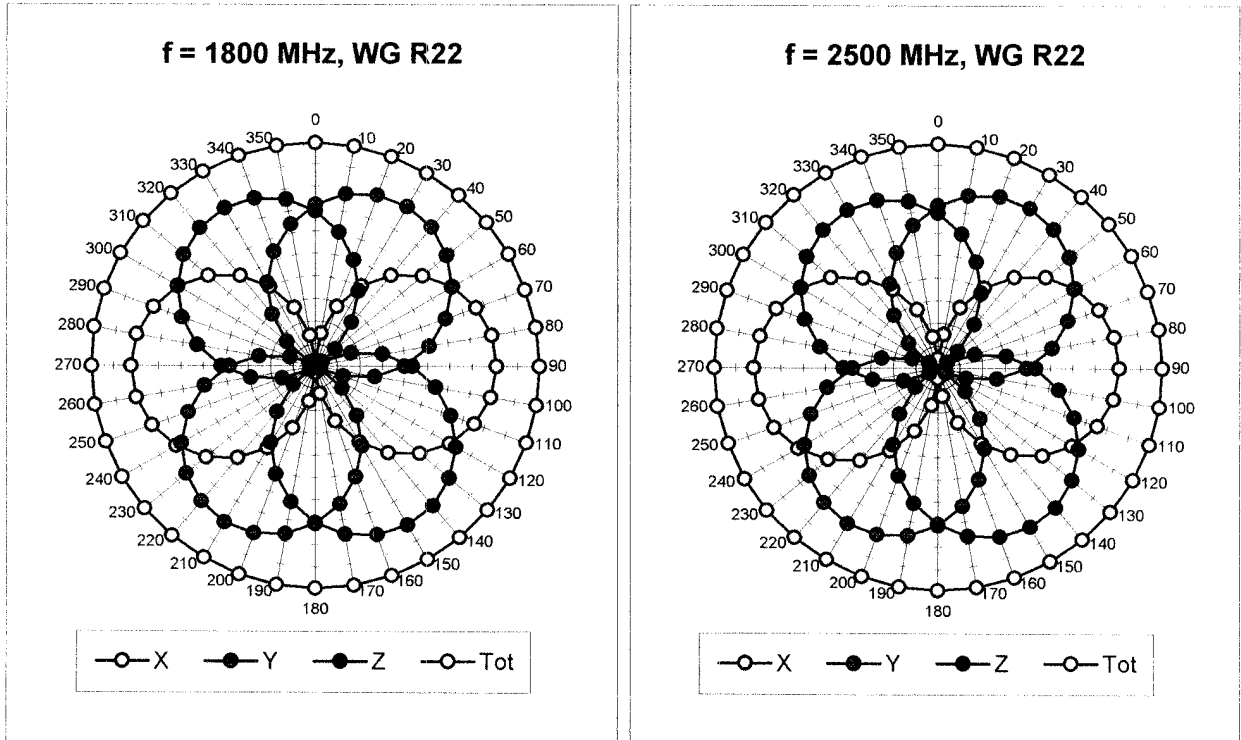

Isotropy Error (ϕ), $\theta = 0^\circ$

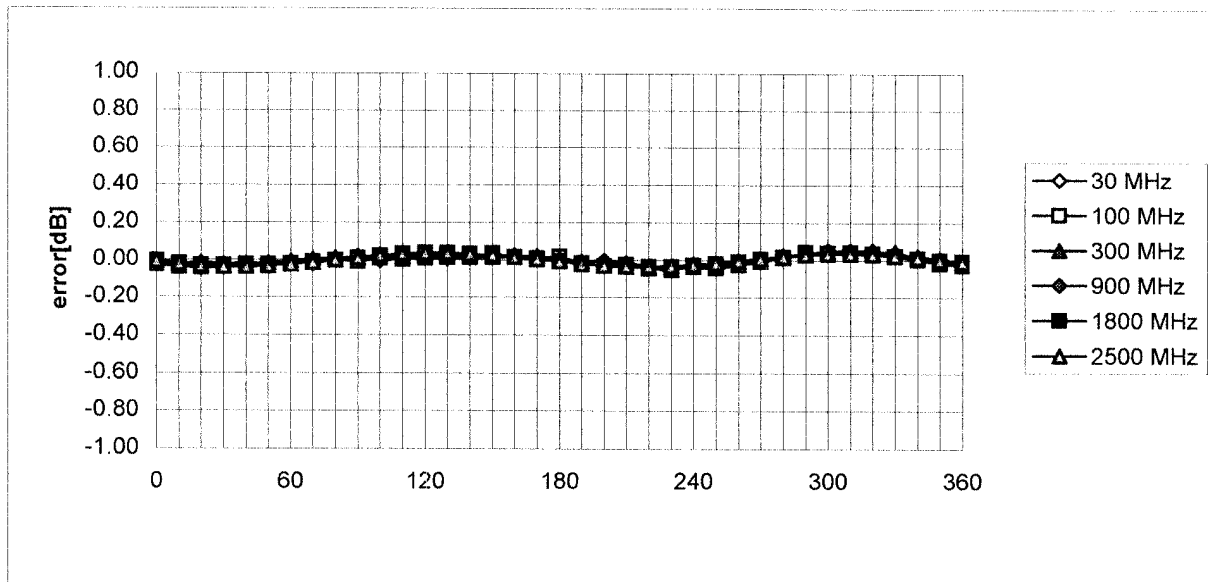

Frequency Response of E-Field

(TEM-Cell:ifi110, Waveguide R22)

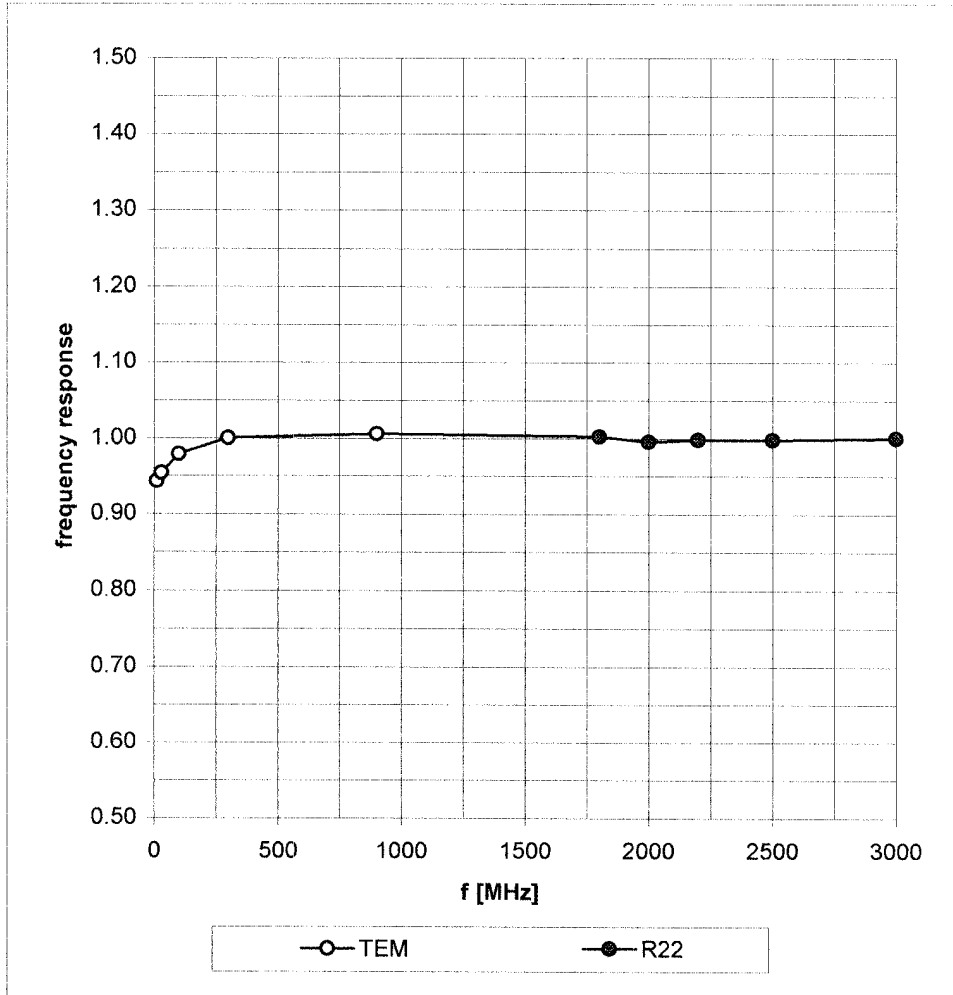

Dynamic Range f(SAR_{brain}) (Waveguide R22)

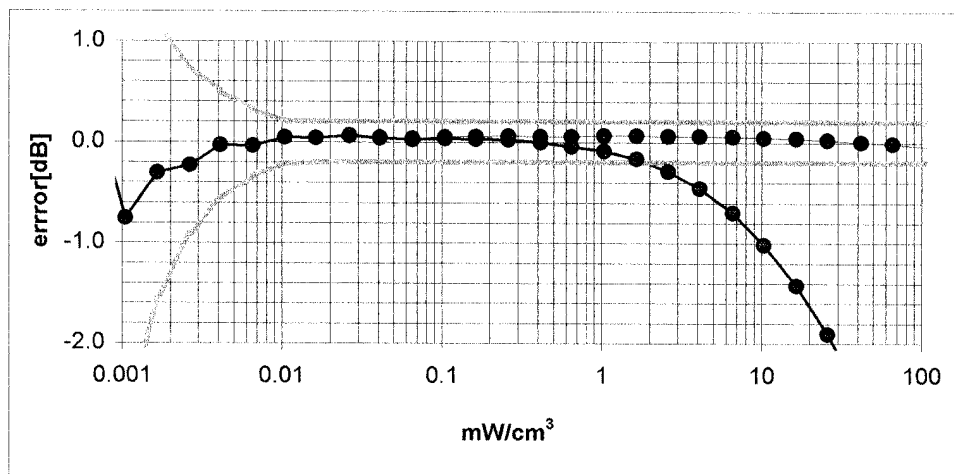
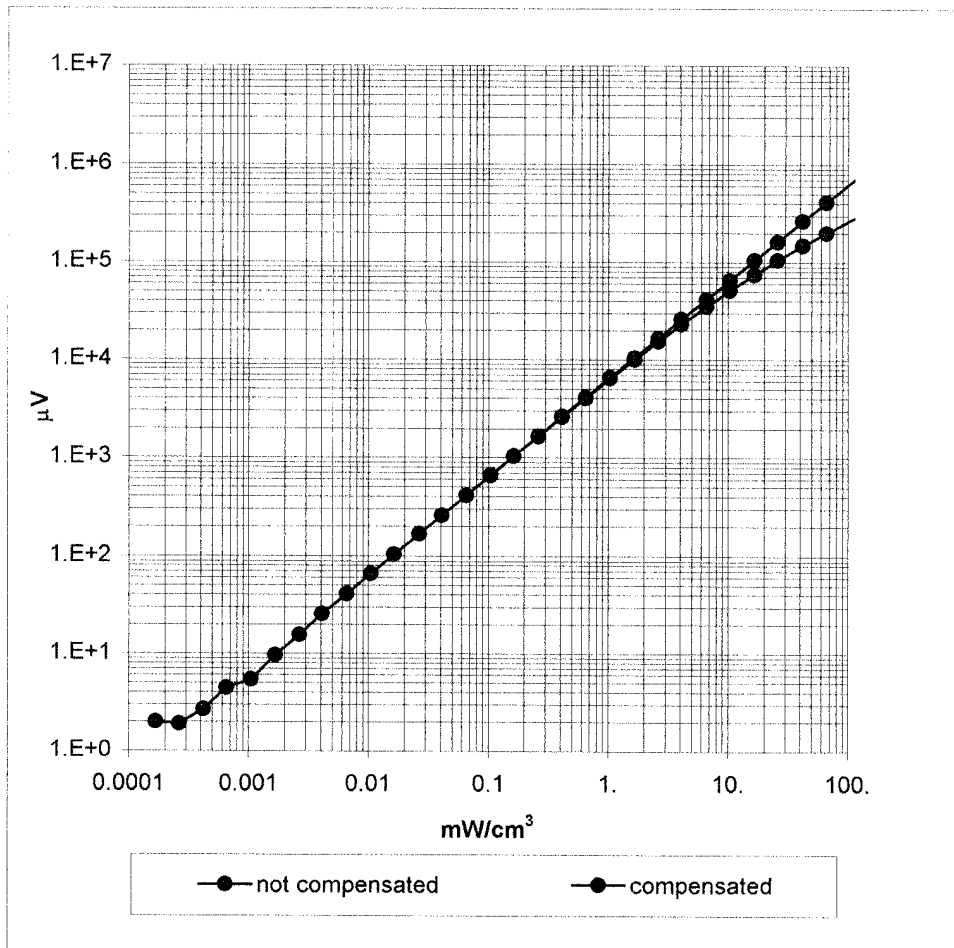

Conversion Factor Assessment

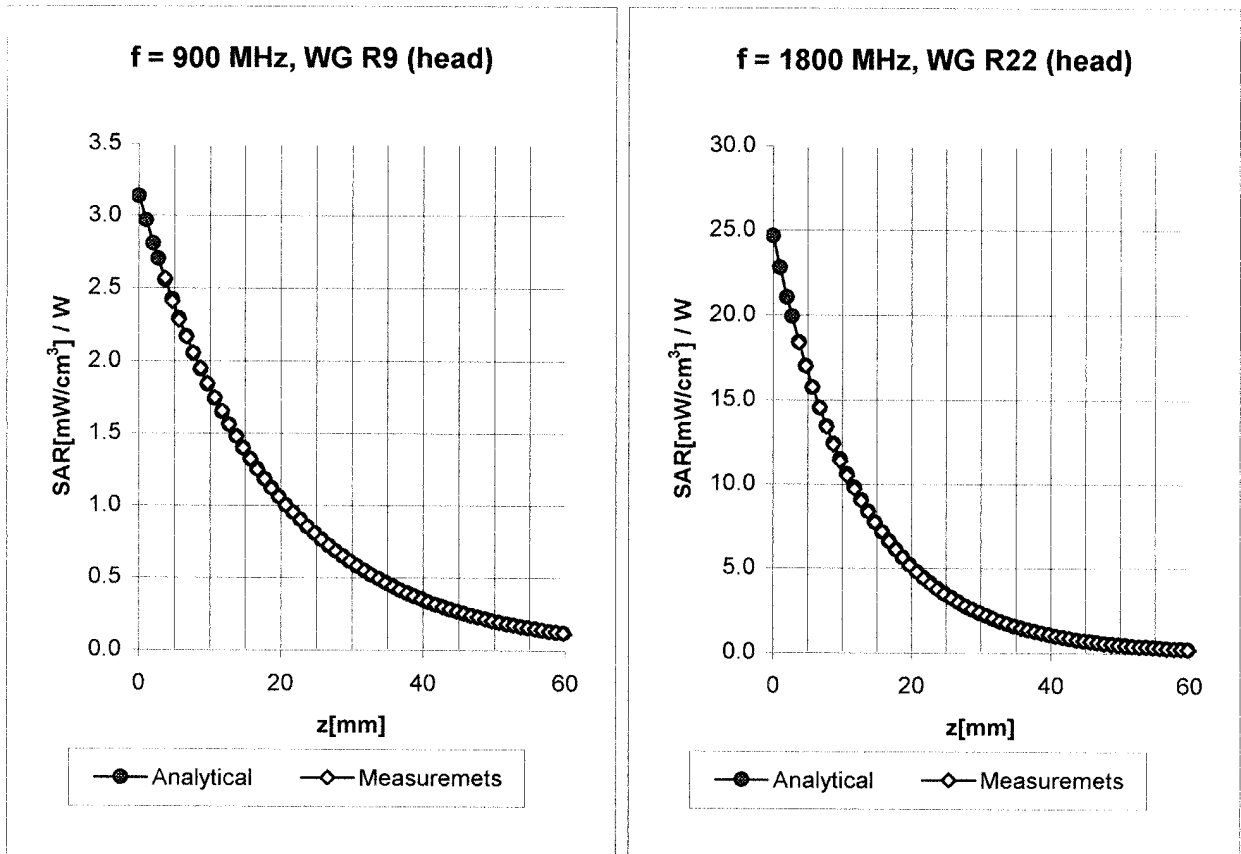

Head	900 MHz	$\epsilon_r = 41.5 \pm 5\%$	$\sigma = 0.97 \pm 5\%$ mho/m
Head	835 MHz	$\epsilon_r = 41.5 \pm 5\%$	$\sigma = 0.90 \pm 5\%$ mho/m
	ConvF X	6.6 $\pm 9.5\%$ (k=2)	Boundary effect:
	ConvF Y	6.6 $\pm 9.5\%$ (k=2)	Alpha 0.37
	ConvF Z	6.6 $\pm 9.5\%$ (k=2)	Depth 2.61
Head	1800 MHz	$\epsilon_r = 40.0 \pm 5\%$	$\sigma = 1.40 \pm 5\%$ mho/m
Head	1900 MHz	$\epsilon_r = 40.0 \pm 5\%$	$\sigma = 1.40 \pm 5\%$ mho/m
	ConvF X	5.2 $\pm 9.5\%$ (k=2)	Boundary effect:
	ConvF Y	5.2 $\pm 9.5\%$ (k=2)	Alpha 0.50
	ConvF Z	5.2 $\pm 9.5\%$ (k=2)	Depth 2.73

Conversion Factor Assessment

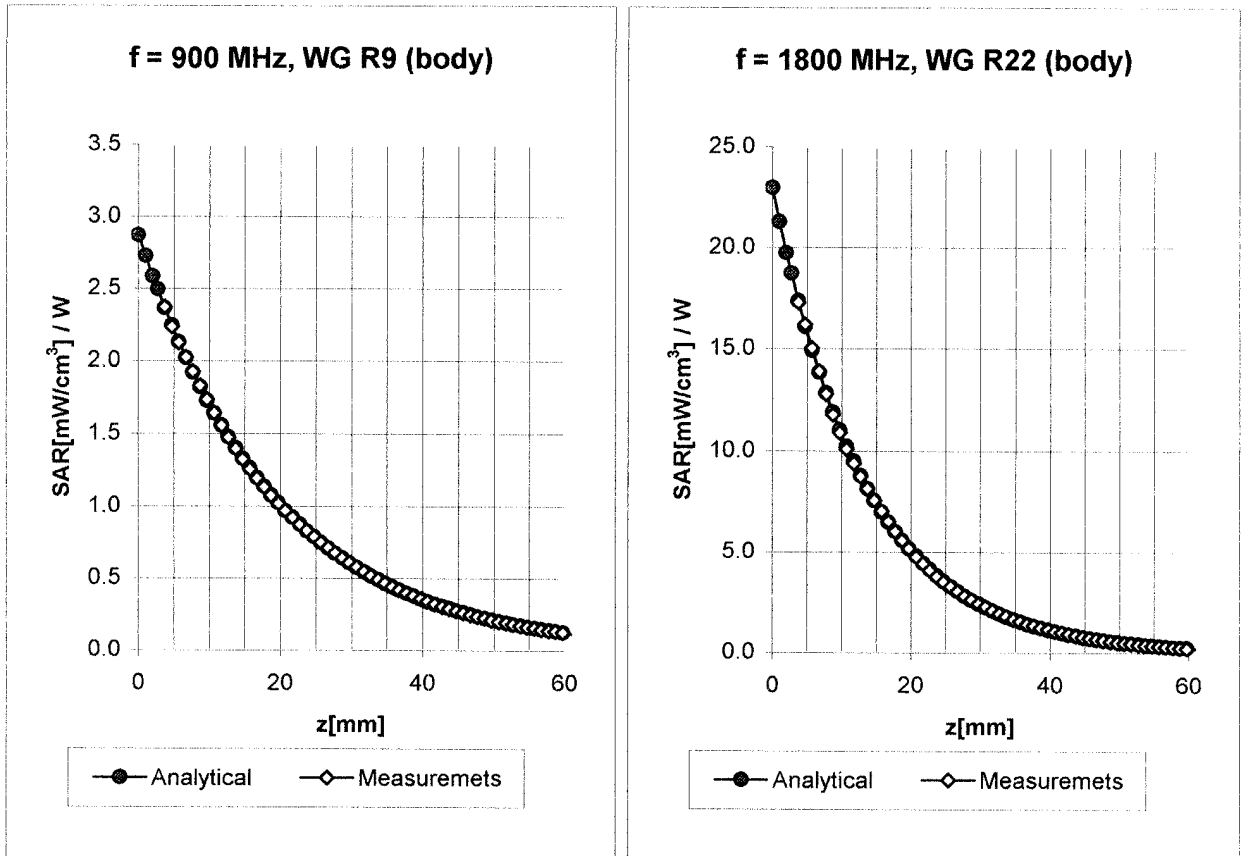

Body	900 MHz	$\epsilon_r = 55.0 \pm 5\%$	$\sigma = 1.05 \pm 5\% \text{ mho/m}$
Body	835 MHz	$\epsilon_r = 55.2 \pm 5\%$	$\sigma = 0.97 \pm 5\% \text{ mho/m}$
	ConvF X	6.4 $\pm 9.5\%$ (k=2)	Boundary effect:
	ConvF Y	6.4 $\pm 9.5\%$ (k=2)	Alpha 0.45
	ConvF Z	6.4 $\pm 9.5\%$ (k=2)	Depth 2.35
Body	1800 MHz	$\epsilon_r = 53.3 \pm 5\%$	$\sigma = 1.52 \pm 5\% \text{ mho/m}$
Body	1900 MHz	$\epsilon_r = 53.3 \pm 5\%$	$\sigma = 1.52 \pm 5\% \text{ mho/m}$
	ConvF X	4.9 $\pm 9.5\%$ (k=2)	Boundary effect:
	ConvF Y	4.9 $\pm 9.5\%$ (k=2)	Alpha 0.60
	ConvF Z	4.9 $\pm 9.5\%$ (k=2)	Depth 2.59

Conversion Factor Assessment

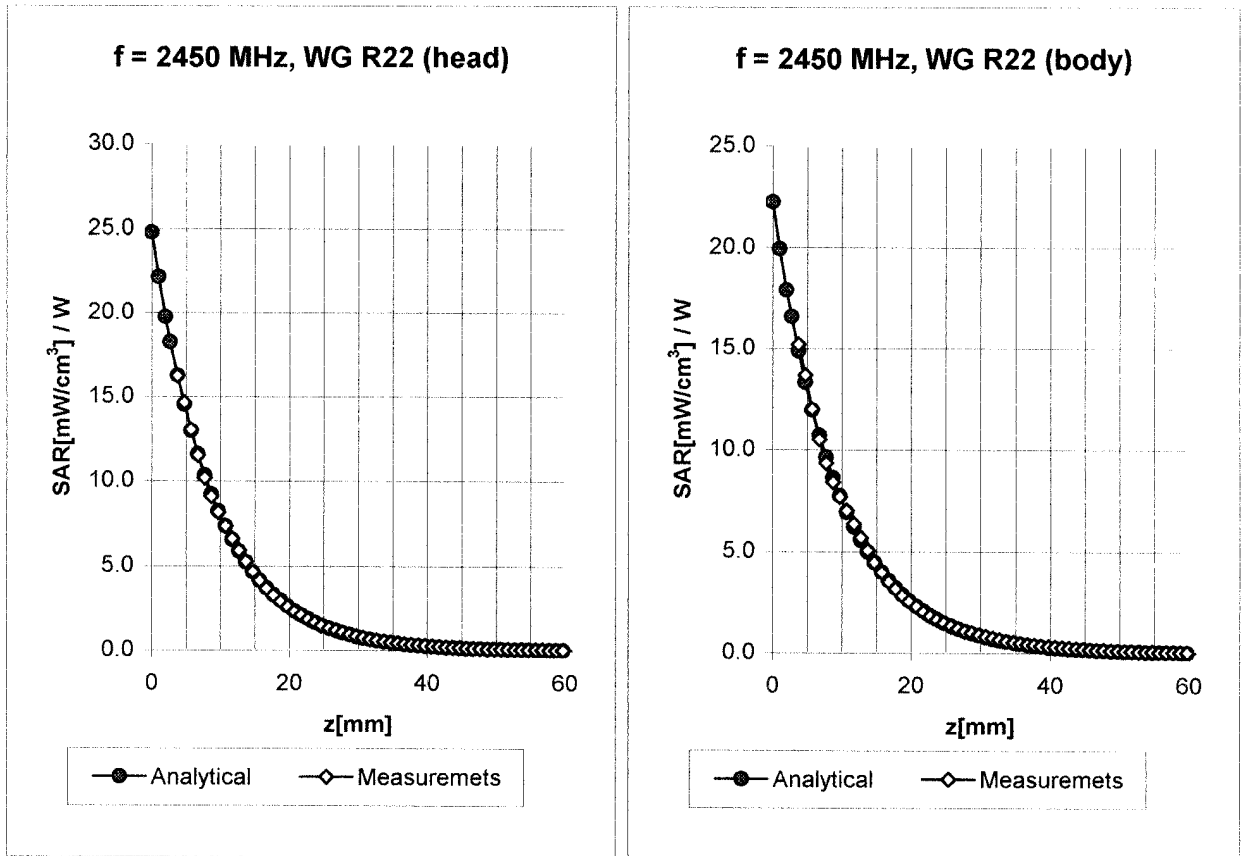

Head	2450	MHz	$\epsilon_r = 39.2 \pm 5\%$	$\sigma = 1.80 \pm 5\%$ mho/m
	ConvF X		5.0 $\pm 8.9\%$ (k=2)	Boundary effect:
	ConvF Y		5.0 $\pm 8.9\%$ (k=2)	Alpha 1.04
	ConvF Z		5.0 $\pm 8.9\%$ (k=2)	Depth 1.85
Body	2450	MHz	$\epsilon_r = 52.7 \pm 5\%$	$\sigma = 1.95 \pm 5\%$ mho/m
	ConvF X		4.6 $\pm 8.9\%$ (k=2)	Boundary effect:
	ConvF Y		4.6 $\pm 8.9\%$ (k=2)	Alpha 1.20
	ConvF Z		4.6 $\pm 8.9\%$ (k=2)	Depth 1.60

Deviation from Isotropy in HSL

Error (θ, ϕ), $f = 900$ MHz

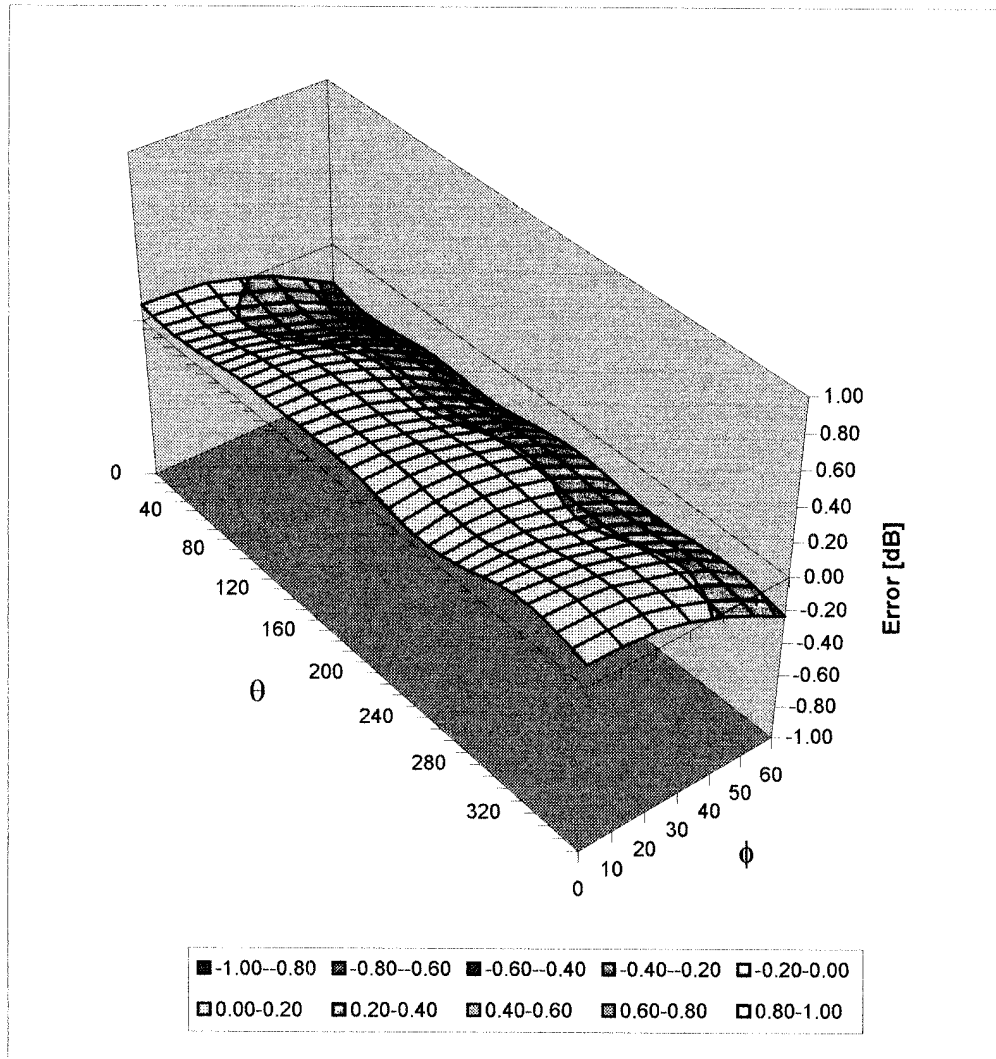

Additional Conversion Factors for Dosimetric E-Field Probe

Type:	ET3DV6
Serial Number:	1387
Place of Assessment:	Zurich
Date of Assessment:	February 28, 2003
Probe Calibration Date:	February 26, 2003

Schmid & Partner Engineering AG hereby certifies that conversion factor(s) of this probe have been evaluated on the date indicated above. The assessment was performed using the FDTD numerical code SEMCAD of Schmid & Partner Engineering AG. Since the evaluation is coupled with measured conversion factors, it has to be recalculated yearly, i.e., following the re-calibration schedule of the probe. The uncertainty of the numerical assessment is based on the extrapolation from measured value at 900 MHz or at 1800 MHz.

Assessed by:

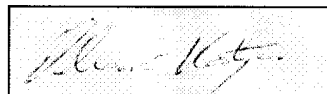

Dosimetric E-Field Probe ET3DV6 SN:1387

Conversion factor (\pm standard deviation)

150 MHz	ConvF	$9.1 \pm 8\%$	$\epsilon_r = 52.3$ $\sigma = 0.76$ mho/m (head tissue)
300 MHz	ConvF	$7.9 \pm 8\%$	$\epsilon_r = 45.3$ $\sigma = 0.87$ mho/m (head tissue)
450 MHz	ConvF	$7.5 \pm 8\%$	$\epsilon_r = 43.5$ $\sigma = 0.87$ mho/m (head tissue)
150 MHz	ConvF	$8.8 \pm 8\%$	$\epsilon_r = 61.9$ $\sigma = 0.80$ mho/m (body tissue)
300 MHz	ConvF	$8.0 \pm 8\%$	$\epsilon_r = 58.2$ $\sigma = 0.92$ mho/m (body tissue)
450 MHz	ConvF	$7.7 \pm 8\%$	$\epsilon_r = 56.7$ $\sigma = 0.94$ mho/m (body tissue)

Test Report S/N:	120403-451ALH
Test Date(s):	December 17-18, 2003
Test Type:	FCC/IC SAR Evaluation

APPENDIX E - MEASURED FLUID DIELECTRIC PARAMETERS

450 MHz System Performance Check & DUT Evaluation (Face)

Measured Fluid Dielectric Parameters (Brain)

December 17, 2003

Frequency	e'	e''
350.000000 MHz	45.4185	39.1058
360.000000 MHz	45.0947	38.4273
370.000000 MHz	44.8831	37.8050
380.000000 MHz	44.6657	37.1500
390.000000 MHz	44.4658	36.5578
400.000000 MHz	44.2547	35.9753
410.000000 MHz	44.0558	35.4192
420.000000 MHz	43.8154	34.9350
430.000000 MHz	43.5253	34.4422
440.000000 MHz	43.2506	34.0370
450.000000 MHz	42.9366	33.7878
460.000000 MHz	42.6905	33.4124
470.000000 MHz	42.4097	33.0953
480.000000 MHz	42.2072	32.7009
490.000000 MHz	42.0033	32.3576
500.000000 MHz	41.8312	31.9553
510.000000 MHz	41.6213	31.5918
520.000000 MHz	41.4104	31.2756
530.000000 MHz	41.2999	30.9384
540.000000 MHz	41.1637	30.5703
550.000000 MHz	40.9664	30.2728

450 MHz System Performance Check

Measured Fluid Dielectric Parameters (Brain)

December 18, 2003

Frequency	ϵ'	ϵ''
350.000000 MHz	45.7774	39.5096
360.000000 MHz	45.4707	38.8392
370.000000 MHz	45.2307	38.1404
380.000000 MHz	45.0006	37.5205
390.000000 MHz	44.7487	36.9031
400.000000 MHz	44.4966	36.3584
410.000000 MHz	44.2676	35.8984
420.000000 MHz	44.0042	35.4058
430.000000 MHz	43.7889	34.9002
440.000000 MHz	43.4966	34.5249
450.000000 MHz	43.1722	34.1632
460.000000 MHz	42.9684	33.7816
470.000000 MHz	42.7342	33.4394
480.000000 MHz	42.5062	33.0230
490.000000 MHz	42.2075	32.6530
500.000000 MHz	42.0240	32.2970
510.000000 MHz	41.8683	31.9671
520.000000 MHz	41.6829	31.6222
530.000000 MHz	41.5372	31.2837
540.000000 MHz	41.4398	30.8777
550.000000 MHz	41.1993	30.6593

450 MHz DUT Evaluation (Body)

Measured Fluid Dielectric Parameters (Muscle)

December 18, 2003

Frequency	ϵ'	ϵ''
350.000000 MHz	58.1055	42.3273
360.000000 MHz	57.8931	41.5048
370.000000 MHz	57.6767	40.6793
380.000000 MHz	57.5254	39.9948
390.000000 MHz	57.3498	39.3251
400.000000 MHz	57.2421	38.7591
410.000000 MHz	57.1032	38.2235
420.000000 MHz	56.9623	37.7521
430.000000 MHz	56.7728	37.2006
440.000000 MHz	56.6038	36.7661
450.000000 MHz	56.3391	36.3402
460.000000 MHz	56.1872	35.8163
470.000000 MHz	56.0037	35.3378
480.000000 MHz	55.8191	34.8243
490.000000 MHz	55.5646	34.4517
500.000000 MHz	55.4256	34.0864
510.000000 MHz	55.3634	33.7340
520.000000 MHz	55.2426	33.4062
530.000000 MHz	55.1567	33.0648
540.000000 MHz	55.1112	32.7085
550.000000 MHz	54.9577	32.4604

Test Report S/N:	120403-451ALH
Test Date(s):	December 17-18, 2003
Test Type:	FCC/IC SAR Evaluation

APPENDIX F - SAR TEST SETUP & DUT PHOTOGRAPHS

FACE-HELD SAR TEST SETUP PHOTOGRAPHS
2.5 cm Separation Distance from Front of Radio to Planar Phantom
with Whip Antenna (P/N: KRA-27M)

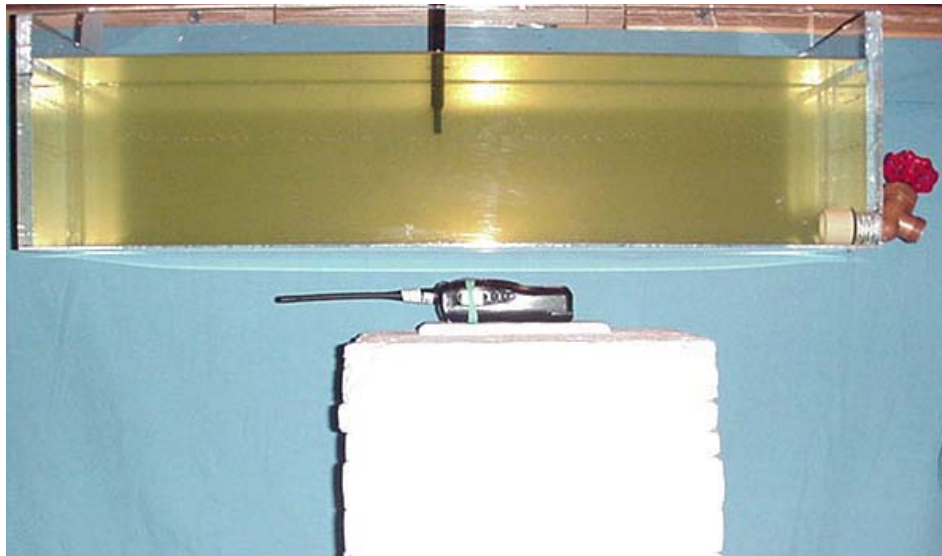
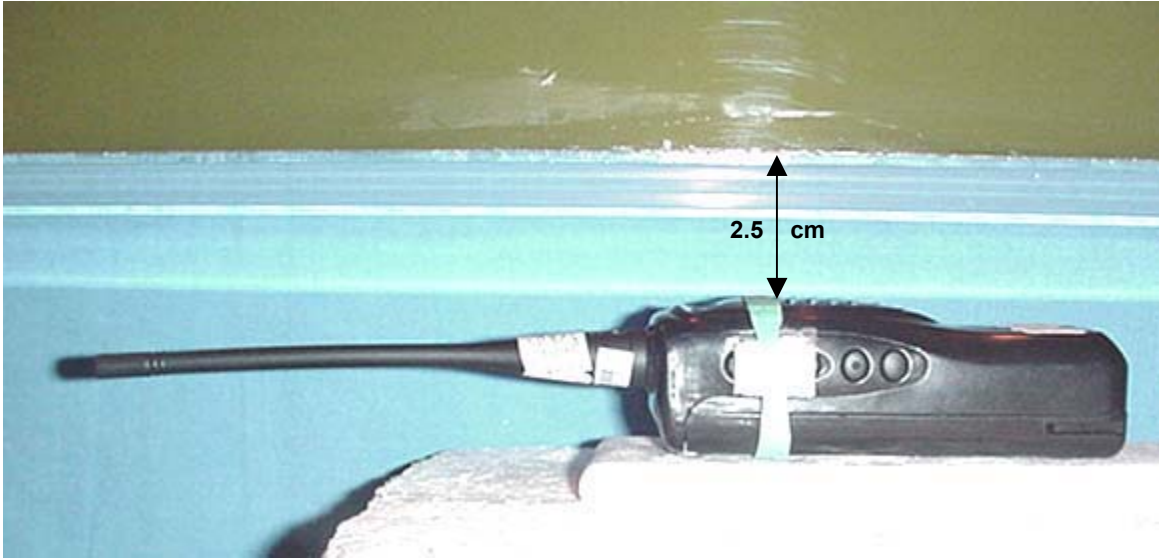

FACE-HELD SAR TEST SETUP PHOTOGRAPHS
2.5 cm Separation Distance from Front of Radio to Planar Phantom
with Stubby Antenna (KRA-23M)

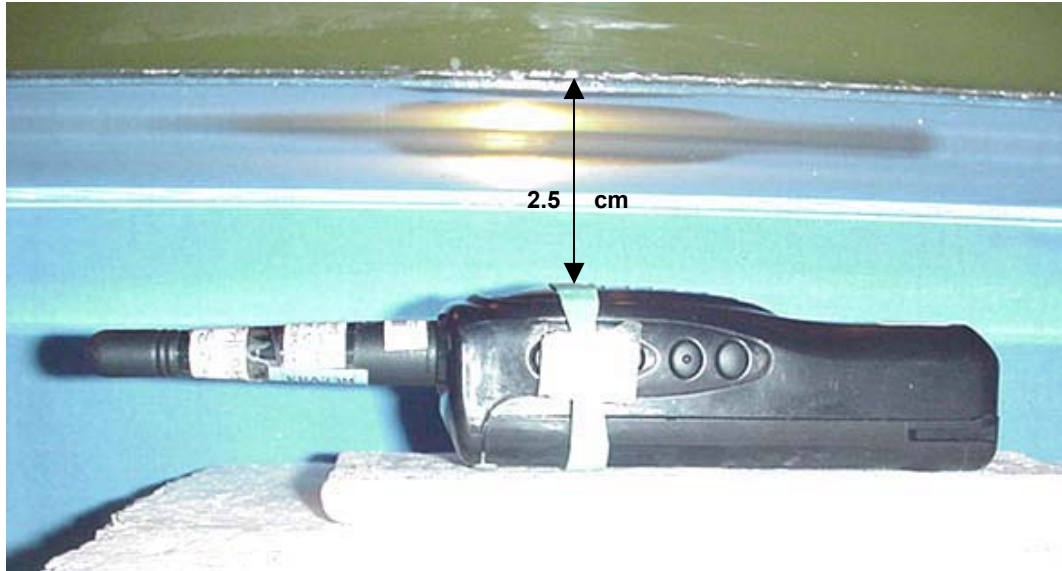

BODY-WORN SAR TEST SETUP PHOTOGRAPHS
1.1 cm Belt-Clip Separation Distance to Planar Phantom
with Whip Antenna & Speaker-Microphone Accessory

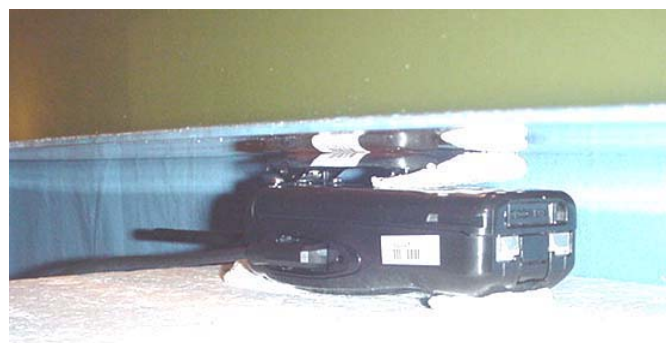
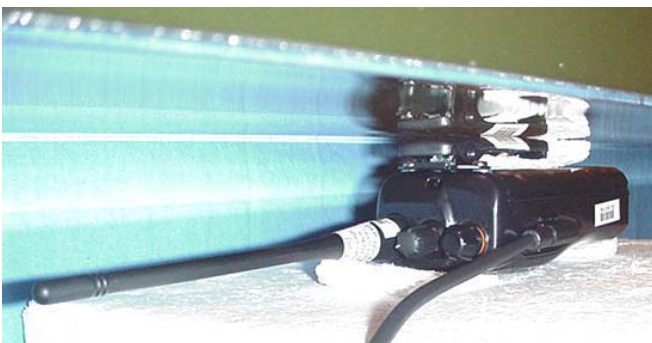
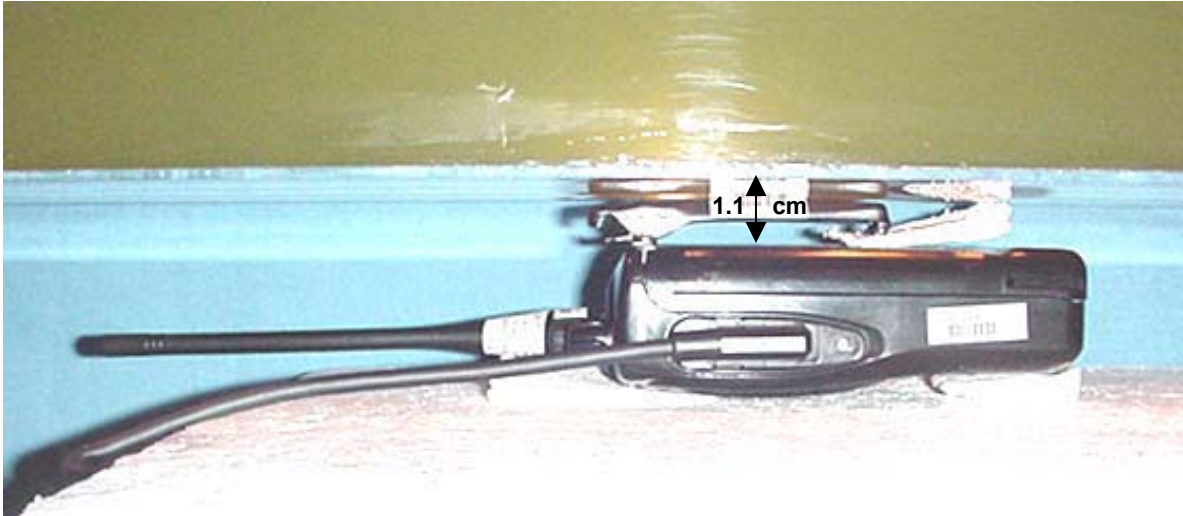

BODY-WORN SAR TEST SETUP PHOTOGRAPHS
1.1 cm Belt-Clip Separation Distance to Planar Phantom
with Stubby Antenna & Speaker-Microphone Accessory

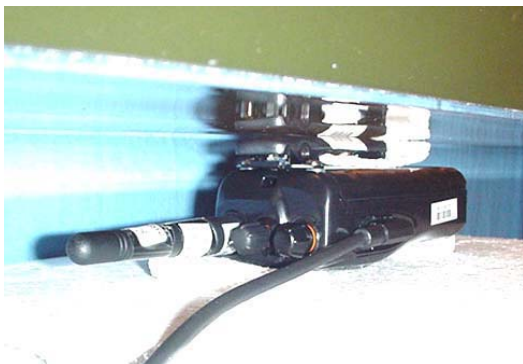
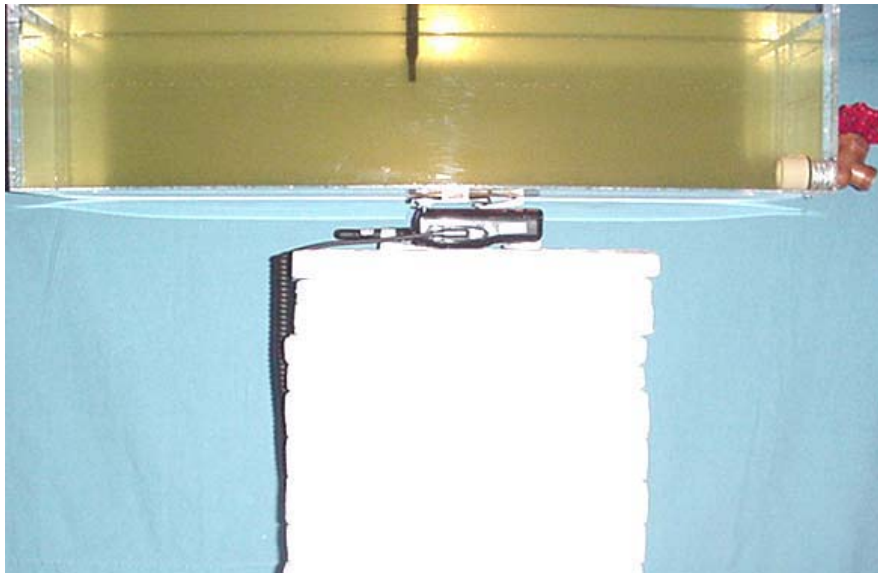
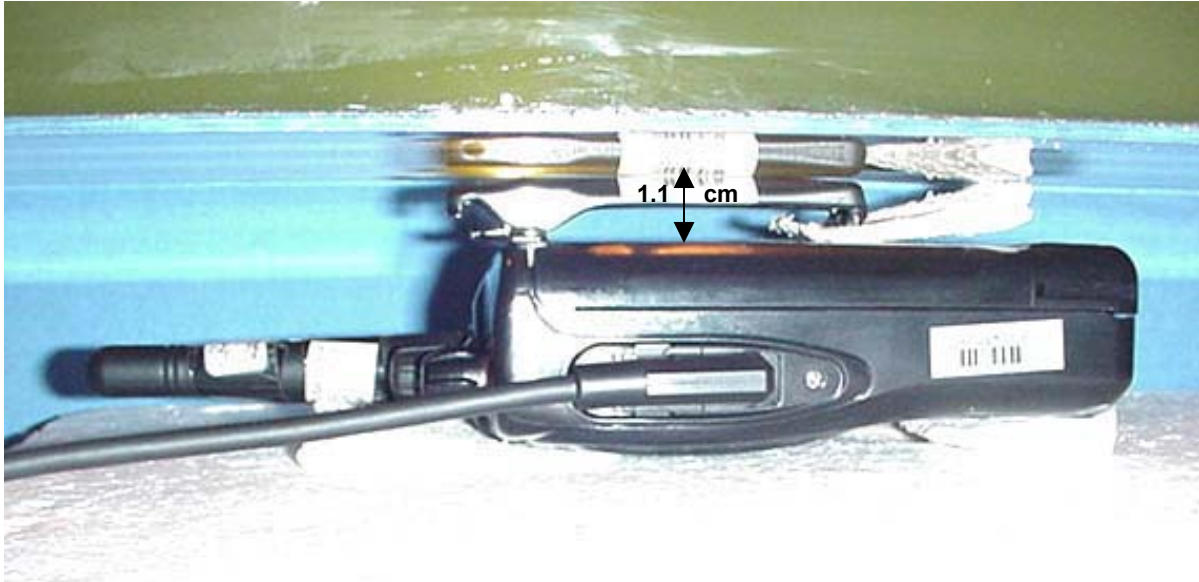

DUT PHOTOGRAPHS



**Front of Radio
with Whip Antenna**



**Front of Radio
with Stubby Antenna**



Top of Radio



Bottom of Radio

DUT PHOTOGRAPHS



Back of Radio - Battery Removed



NiCd Battery Pack



NiMH Battery Pack



Back of Radio with Belt-Clip Accessory



Left Side of Radio with Belt-Clip Accessory



Right Side of Radio with Belt-Clip Accessory

DUT PHOTOGRAPHS



Front of Radio with Speaker-Microphone Accessory



Front of Speaker-Microphone Accessory



Back of Speaker-Microphone Accessory