



Flom Test Lab

EMI, EMC, RF Testing Experts Since 1963

toll-free: (866) 311-3268

fax: (480) 926-3598

www.flomlabs.com

info@flomlabs.com

Date: August 28, 2008

Applicant: Kenwood USA Corporation
Communications Division
2970 Johns Creek Court, Suite 100
Suwanee, GA 30024

Attention of: Joel E. Berger, Research & Development
JBerger@kenwoodusa.com
(678) 474-4722; FAX: (678) 474-4731

Mailing: Kenwood USA Corporation
Communications Division
2970 Johns Creek Court, Suite 100
Suwanee, GA 30024

Attention of: Joel E. Berger, Research & Development
JBerger@kenwoodusa.com
(678) 474-4722; FAX: (678) 474-4731

Equipment: TK-3102G-1
FCC ID: ALH30923110
FCC Rules: Part 22, 74, 90
Gentlemen:

Enclosed please find your copy of the Engineering Test Report for which you are subject to the restrictions as listed on the attached summary.

As you know, the FCC, after a TCB issues a Grant, still has 30 days to review a submission and request added information. It is your decision whether or not to market the equipment subject to a possible recall before the end of the 30 days.

If your equipment is still retained by us, it will be returned to you 30 days after approval is achieved. Our invoice for services has been directed to your Accounts Payable Department.

Should you need any clarification, just fax or phone. Thank you again for this order - it has been a pleasure to be of service.

Sincerely yours,

Hoosamuddin S. Bandukwala, Lab Director

enclosure(s)
HSB/ms



Memo

Date: August 28, 2008

Applicant: Kenwood USA Corporation
Communications Division
2970 Johns Creek Court, Suite 100
Suwanee, GA 30024

Equipment: TK-3102G-1
FCC ID: ALH30923110

Please note that the enclosed Reports reflect the results of tests performed to the currently published Federal Communications Commissions Rules and Regulations.

Should the FCC's Examiners' interpretations request new and unpublished requirements, we will be pleased to provide them. We will invoice you accordingly, i.e. for the time spent on re-testing, providing the amended pages and/or Reports and for the time necessary to be spent on electronic filing. We will of course provide you with copies of any of the additions.

We regret any added expense to the Applicants, but of late the FCC continues to change their requirements without any prior written publication and/or notices.

As in the past, we will continue to provide all liaison with the FCC necessary for the successful conclusion of your project and the receipt of your Grant of Equipment Authorization.

Sincerely yours,

Hoosamuddin S. Bandukwala, Lab Director

Summary of Restrictions

1. All submissions to the FCC are subject to **their** Examiner's interpretation.
2. Please allow from 60 to 90 days before hearing from the FCC with regard to any submission.
3. The FCC can set aside any action; modify or set aside any action, within 30 days. (FCC Rule 1.108, 1.113).
4. Under Rule 2.803, if device is not type accepted/certificated then it must **not** be sold, leased, offered for sale, imported, shipped or distributed or advertised for sale.
5. FCC can revoke its certificates at any time if the equipment does not meet or **continue** to meet their Rules. (Rule Parts 2.927, 2.939).
6. FCC can request a sample at any time (2.936).

Flom Test Lab

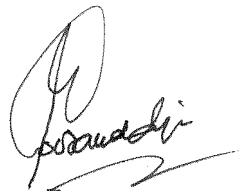

Hoosamuddin S. Bandukwala, Lab Director



Flom Test Lab
EMI, EMC, RF Testing Experts Since 1963

toll-free: (866) 311-3268

fax: (480) 926-3598

www.flomlabs.com

info@flomlabs.com

Date: August 28, 2008

Federal Communications Commission
Via: Electronic Filing

Attention: Authorization & Evaluation Division

Applicant: Kenwood USA Corporation
Equipment: TK-3102G-1
FCC ID: ALH30923110
FCC Rules: Part 22, 74, 90

Gentlemen:

On behalf of the Applicant, enclosed please find Application Form 731, Engineering Test Report and all pertinent documentation, the whole for approval of the referenced equipment as shown.

We trust the same is in order. Should you need any further information, kindly contact the writer who is authorized to act as agent.

Sincerely yours,

Hoosamuddin S. Bandukwala, Lab Director

enclosure(s)
cc: Applicant
HSB/ms

Flom Test Labs
3356 N. San Marcos Place, Suite 107
Chandler, Arizona 85225-7176
(866) 311-3268 phone, (480) 926-3598 fax

p0850021, d0880036
Rev 3.0



Flom Test Lab
EMI, EMC, RF Testing Experts Since 1963

toll-free: (866) 311-3268

fax: (480) 926-3598

www.flomlabs.com

info@flomlabs.com

Test Report

For Class II Permissive Change

Of **Model:** TK-3102G-1

to

Federal Communications Commission

Rule Part(s) 22, 74, 90

Date of report: August 28, 2008

On the Behalf of the Applicant:

Kenwood USA Corporation

At the Request of:

Kenwood USA Corporation
Communications Division
2970 Johns Creek Court, Suite 100
Suwanee, GA 30024

Attention of:

Joel E. Berger, Research & Development
JBerger@kenwoodusa.com
(678) 474-4722; FAX: (678) 474-4731

Supervised by:

Hoosamuddin S. Bandukwala, Lab Director

Revision History

Revision	Date	Revised By	Reason for revision
1.0	August 28, 2008	Mark Sechrist	Original Document
2.0	October 20, 2008	Flom Test Lab	Remove Part 80 & 95A
3:0	December 8, 2008	Flom Test Lab	Add Freq for 74,90,22

The Applicant has been cautioned as to the following:

15.21 **Information to the User.**

The users manual or instruction manual for an intentional radiator shall caution the user that changes or modifications not expressly approved by the party responsible for compliance could void the user's authority to operate the equipment.

15.27(a) **Special Accessories.**

Equipment marketed to a consumer must be capable of complying with the necessary regulations in the configuration in which the equipment is marketed. Where special accessories, such as shielded cables and/or special connectors are required to enable an unintentional or intentional radiator to comply with the emission limits in this part, the equipment must be marketed with, i.e. shipped and sold with, those special accessories. However, in lieu of shipping or packaging the special accessories with the unintentional or intentional radiator, the responsible party may employ other methods of ensuring that the special accessories are provided to the consumer, without additional charge.

Information detailing any alternative method used to supply the special accessories for a grant of equipment authorization or retained in the verification records, as appropriate. The party responsible for the equipment, as detailed in § 2.909 of this chapter, shall ensure that these special accessories are provided with the equipment. The instruction manual for such devices shall include appropriate instructions on the first page of text concerned with the installation of the device that these special accessories must be used with the device. It is the responsibility of the user to use the needed special accessories supplied with the equipment.

**Testimonial
and
Statement of Certification**

This is to Certify:

1. **That** the application was prepared either by, or under the direct supervision of, the undersigned.
2. **That** the technical data supplied with the application was taken under my direction and supervision.
3. **That** the data was obtained on representative units, randomly selected.
4. **That**, to the best of my knowledge and belief, the facts set forth in the application and accompanying technical data are true and correct.

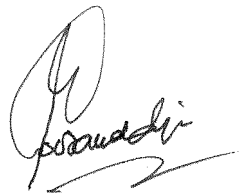

Certifying Engineer:

Hoosamuddin S. Bandukwala, Lab Director

Table of Contents

<u>Rule</u>	<u>Description</u>	<u>Page</u>
2.1033(c)(14)	Rule Summary	2
	Standard Test Conditions and Engineering Practices	3
	Expository Statement for Permissive Changes	4
2.1033(c)	General Information Required	5
2.1046(a)	Carrier Output Power (Conducted)	7
2.1053(a)	Field Strength of Spurious Radiation	8
	Test Equipment Utilized	11

Required information per ISO 17025-2005, paragraph 5.10.2:

a) **Test Report**

b) Laboratory: Flom Test Lab
(FCC: 31040/SIT) 3356 N. San Marcos Place, Suite 107
(Canada: IC 2044-A) Chandler, AZ 85225

c) Report Number: d0880036

d) Client: Kenwood USA Corporation
Communications Division
2970 Johns Creek Court, Suite 100
Suwanee, GA 30024

e) Identification: TK-3102G-1

EUT Description: FCC ID ALH30923110

f) EUT Condition: Not required unless specified in individual tests.

g) Report Date: August 28, 2008
EUT Received:

h, j, k): As indicated in individual tests.

i) Sampling method: No sampling procedure used.

l) Uncertainty: In accordance with FTL internal quality manual.

m) Supervised by:

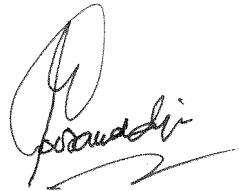

Hoosamuddin S. Bandukwala, Lab Director

n) Results: The results presented in this report relate only to the item tested.

o) Reproduction: This report must not be reproduced, except in full, without written permission from this laboratory.

Sub-part

2.1033(c)(14):

Test and Measurement Data

All tests and measurement data shown were performed in accordance with FCC Rules and Regulations, Volume II; Part 2, Sub-part J, Sections 2.947, 2.1033(c), 2.1041, 2.1046, 2.1047, 2.1079, 2.1051, 2.1053, 2.1055, 2.1057 and the following individual Parts:

- 15 – Radio Frequency Devices (unlicensed)
- 21 – Domestic Public Fixed Radio Services
- 22 – Public Mobile Services
- 22 Subpart E Paging and Radio Telephone Service
- 22.901(d) - Alternative technologies and auxiliary services
- 23 – International Fixed Public Radiocommunication services
- 24 – Personal Communications Services
- 74 Subpart H - Low Power Auxiliary Stations
- 80 – Stations in the Maritime Services
- 80 Subpart E - General Technical Standards
- 80 Subpart F - Equipment Authorization for Compulsory Ships
- 80 Subpart K - Private Coast Stations and Marine Utility Stations
- 80 Subpart S - Compulsory Radiotelephone Installations for Small Passenger Boats
- 80 Subpart T - Radiotelephone Installation Required for Vessels on the Great Lakes
- 80 Subpart U - Radiotelephone Installations Required by the Bridge-to-Bridge Act
- 80 Subpart V - Emergency Position Indicating Radio Beacons (EPIRB'S)
- 80 Subpart W - Global Maritime Distress and Safety System (GMDSS)
- 80 Subpart X - Voluntary Radio Installations
- 87 – Aviation Services
- 90 – Private Land Mobile Radio Services
- 94 – Private Operational-Fixed Microwave Service
- 95 Subpart A - General Mobile Radio Service (GMRS)
- 95 Subpart C - Radio Control (R/C) Radio Service
- 95 Subpart D - Citizens Band (CB) Radio Service
- 95 Subpart E - Family Radio Service
- 95 Subpart F - Interactive Video and Data Service (IVDS)
- 97 - Amateur Radio Service
- 101 – Fixed Microwave Services

Standard Test Conditions and Engineering Practices

Except as noted herein, the following conditions and procedures were observed during the testing:

In accordance with ANSI/TIA-603-C-2004, and unless otherwise indicated in the specific measurement results, the ambient temperature of the actual EUT was maintained within the range of 10° to 40°C (50° to 104 °F) unless the particular equipment requirements specify testing over a different temperature range. Also, unless otherwise indicated, the humidity levels were in the range of 10% to 90% relative humidity.

Measurement results, unless otherwise noted, are worst-case measurements.

A2LA

“A2LA has accredited Flom Test Labs, Inc. Chandler, AZ for technical competence in the field of Electrical testing. The accreditation covers the specific tests and types of tests listed on the agreed scope of accreditation. This laboratory meets the requirements of ISO 17025:2005 ‘General Requirements for the Competence of Testing and Calibration Laboratories’ and any additional program requirements in the identified field of testing.”

Please refer to www.a2la.org for current scope of accreditation.

Certificate number: 2152.01



IC O.A.T.S. Number: 2044A-1

Expository Statement for Permissive Changes

Following components have been replaced by similar or equivalent parts.

RX Mixer and RF AMP changed
Q202 from 3SK228 to 3SK318 (FET,MIXER)
Q203 from 3SK228 to 3SK318 (FET,RF AMP)

External cosmetic change.

This transceiver has been evaluated/tested and complies with the standards listed below, in regards to Radio Frequency (RF) energy and electromagnetic energy (EME) generated by the transceiver.

-FCC RF exposure limits for Occupational Use Only. RF Exposure limits adopted by the FCC are generally based on recommendations from the National Council on Radiation Protection and Measurements, & the American National Standards Institute.

-FCC OET Bulletin 65 Edition 97-01 Supplement C

-American National Standards Institute (C95.1 1992)

-American National Standards Institute (C95.3 1992)

Added RF Safety Information

List of General Information Required for Certification

In Accordance with FCC Rules and Regulations,
Volume II, Part 2 and to

Sub-part 2.1033

(c)(1):

Name and Address of Applicant:

Kenwood USA Corporation
Communications Division
2970 Johns Creek Court, Suite 100
Suwanee, GA 30024

Manufacturer:

Kenwood Corporation
14-6, Dogenzaka 1-Chome
Shibuya-ku, Tokyo 150, Japan
OR
Kenwood Electronics Technologies PTE Ltd.
1 Ang Mo Kio Street 63
Singapore 569110

(c)(2): **FCC ID:**

ALH30923110

Model Number:

TK-3102G-1

(c)(3): **Instruction Manual(s):**

Please see attached exhibits

(c)(4): **Type of Emission:**

16K0F3E, 11K0F3E

(c)(5): **Frequency Range, MHZ:**

Part 22 454.025 – 454.650
459.025 – 459.650
Part 74 450.03125 – 450.8625
455.03125 – 455.8625
Part 90 451.18125 – 462.51875
456.18125 – 462.51875

(c)(6): **Power Rating, Watts:**

_____ Switchable

_____ Variable

4

_____ N/A

FCC Grant Note:

N/A

(c)(7): **Maximum Power Rating, Watts:**

300 watts

DUT Results:

Passes X Fails

(c)(8): **Test and Measurement Data:**

Follows:

Name of Test: Carrier Output Power (Conducted)
Specification: 2.1046(a)
Test Equipment Utilized: i00228, i00317

Test Date: August 27, 2008

Measurement Procedure

- A) The EUT was connected to a resistive coaxial attenuator of normal load impedance, and the unmodulated output power was measured by means of an RF Power Meter.
- B) Measurement accuracy is $\pm 3\%$.

Transmitter Test Set-Up: RF Power Output

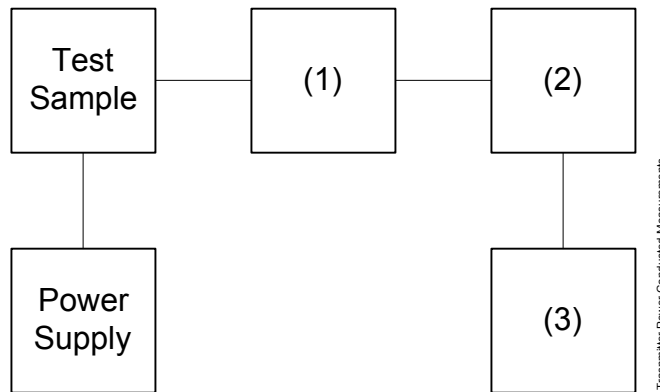

Measurement Results
(Worst case)

Frequency of Carrier, MHz = 460.025
 Ambient Temperature = 23°C \pm 3°C

Power Setting	RF Power, Watts
High	4

Performed by:

 Mark Sechrist

Name of Test: Field Strength of Spurious Radiation
Specification: 2.1053(a)
Test Equipment Utilized: i00049, i00089, i00103

Test Date: August 28, 2008

Measurement Procedure

Definition:

Radiated spurious emissions are emissions from the equipment when transmitting into a non-radiating load on a frequency or frequencies which are outside an occupied band sufficient to ensure transmission of information of required quality for the class of communications desired.

Method of Measurement:

- A) Connect the equipment as illustrated.

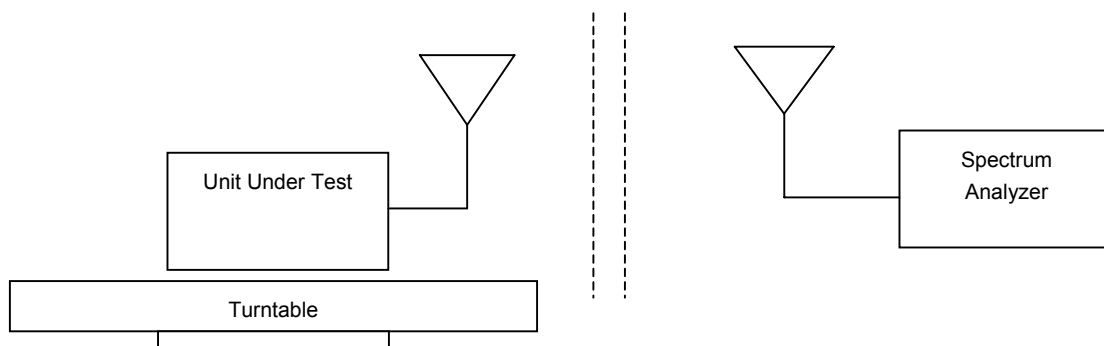

- B) Adjust the spectrum analyzer for the following settings:
 1) Resolution Bandwidth 100 kHz (<1 GHz), 1 MHz (> 1GHz).
 2) Video Bandwidth ≥ 3 times Resolution Bandwidth, or 30 kHz (22.917)
 3) Sweep Speed ≤ 2000 Hz/second
 4) Detector Mode = Mean or Average Power
- C) Place the transmitter to be tested on the turntable in the standard test site. The transmitter is transmitting into a non-radiating load that is placed on the turntable. The RF cable to this load should be of minimum length.
- D) For each spurious measurement the test antenna should be adjusted to the correct length for the frequency involved. This length may be determined from a calibration ruler supplied with the equipment. Measurements shall be made from the lowest radio frequency generated in the equipment to the tenth harmonic of the carrier, except for the region close to the carrier equal to \pm the test bandwidth (see section 1.3.4.4).
- E) For each spurious frequency, raise and lower the test antenna from 1 m to 4 m to obtain a maximum reading on the spectrum analyzer with the test antenna at horizontal polarity. Repeat this procedure to obtain the highest possible reading. Record this maximum reading.
- F) Repeat step E) for each spurious frequency with the test antenna polarized vertically.

G) Reconnect the equipment as illustrated below.

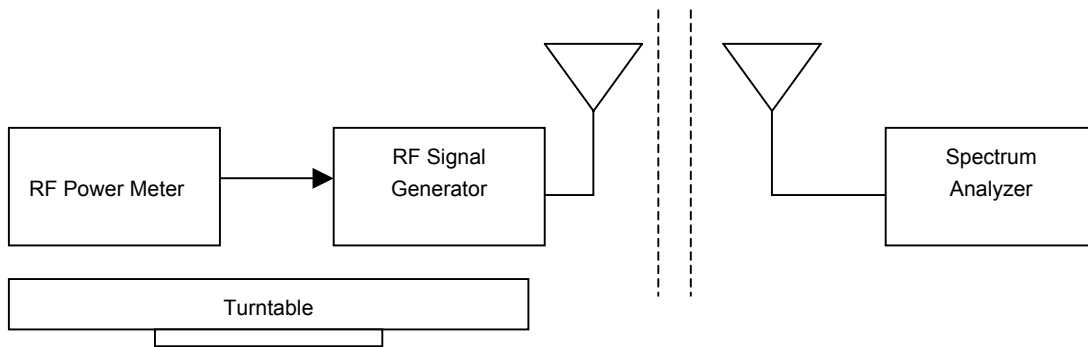

H) Keep the spectrum analyzer adjusted as in step B).

I) Remove the transmitter and replace it with a substitution antenna (the antenna should be half-wavelength for each frequency involved). The center of the substitution antenna should be approximately at the same location as the center of the transmitter. At lower frequencies, where the substitution antenna is very long, this will be impossible to achieve when the antenna is polarized vertically. In such case the lower end of the antenna should be 0.3 m above the ground.

J) Feed the substitution antenna at the transmitter end with a signal generator connected to the antenna by means of a non-radiating cable. With the antennas at both ends horizontally polarized and with the signal generator tuned to a particular spurious frequency, raise and lower the test antenna to obtain a maximum reading at the spectrum analyzer. Adjust the level of the signal generator output until the previously recorded maximum reading for this set of conditions is obtained. This should be done carefully repeating the adjustment of the test antenna and generator output.

K) Repeat step J) with both antennas vertically polarized for each spurious frequency.

L) Calculate power in dBm into a reference ideal half-wave dipole antenna by reducing the readings obtained in steps J) and K) by the power loss in the cable between the generator and the antenna and further corrected for the gain of the substitution antenna used relative to an ideal half-wave dipole antenna.

M) The levels recorded in step L) are absolute levels of radiated spurious emissions in dBm. The radiated spurious emissions in dB can be calculated by the following:

Radiated spurious emissions dB =

$$10\log_{10}(\text{TX power in watts}/0.001) - \text{the levels in step I)}$$

NOTE: It is permissible that other antennas provided can be referenced to a dipole.

Name of Test: Field Strength of Spurious Radiation

Measurement Results

g0880066: 2008-Aug-28 Thu 13:54:00
STATE: 2:High Power

Ambient Temperature: 23°C ± 3°C

Frequency Tuned, MHz	Frequency Emission, MHz	ERP, dBm	Margin, dBm
460	920.050000	-55	-42
460	1380.075000	-46.6	-33.6
460	1840.100000	-43.8	-30.8
460	2300.125000	-43.2	-30.2
460	2761.150000	-40.9	-27.9
460	3220.175000	-41.2	-28.2
460	3680.200000	-39.4	-26.4
460	4140.225000	-39	-26.0
460	4600.250000	-39.4	-26.4

Performed by:

Mark Sechrist

Test Equipment Utilized

Description	MFG	Model Number	FTL Asset Number	Last Cal Date	Cal Due Date
RF Pre-Amplifier	HP	8449	i00028	1/23/07	1/23/09
Spectrum Analyzer	HP	8563E	i00029	3/9/07	3/9/08
Spectrum Analyzer	HP	8566B	i00049	8/18/07	8/18/08
Log Periodic Antenna	APREL	2001	I00089	10/19/07	10/19/09
Horn Antenna	EMCO	3115	i00103	9/5/06	9/5/08
Power Meter	HP	E4418B	i00228	9/6/07	9/6/08
Power sensor	HP	8481A	i00317	9/6/07	9/6/08

In addition to the above listed equipment standard RF connectors and cables were utilized in the testing of the described equipment. Prior to testing these components were tested to verify proper operation.

END OF TEST REPORT