

MFA **M. Flom Associates, Inc. - Global Compliance Center**
3356 North San Marcos Place, Suite 107, Chandler, Arizona 85224-1571
www.goodnet.com/~mflom, (602) 926-3100, FAX: 926-3598

Date: September 8, 1998

Federal Communications Commission
EQUIPMENT APPROVAL SERVICES
P.O. Box 358315
Pittsburgh, PA 15251-5315

Attention: Authorization & Evaluation Division
Applicant: Kenwood Communications Corporation
Equipment: TK-3101
FCC ID: ALH27303110
FCC Rules: 22, 74, 80, 90, 95

Gentlemen:

On behalf of the Applicant, enclosed please find Application Form 731, Engineering Test Report and all pertinent documentation, the whole for approval of the referenced equipment as shown.

Filing fees are attached.

We trust the same is in order. Should you need any further information, kindly contact the writer who is authorized to act as agent.

Sincerely yours,



Morton Flom, P. Eng.

enclosure(s)
CERTIFIED MAIL, R.R.R.

cc: Applicant
MF/cvr

LIST OF EXHIBITS
(TYPE ACCEPTANCE - REVISED 3/24/97)

APPLICANT: Kenwood Communications Corporation

FCC ID: ALH27303110

BY APPLICANT:

- 1. LETTER OF AUTHORIZATION
- 2. IDENTIFICATION DRAWINGS
 - x LABEL
 - x LOCATION OF LABEL
 - x COMPLIANCE STATEMENT
 - x LOCATION OF COMPLIANCE STATEMENT
- 3. PHOTOGRAPHS (2.983(g))
- 4. PART 90.203(e) & (g) ATTESTATION
- 5. DOCUMENTATION: 2.983(d)
 - (6) BLOCK DIAGRAM 1
 - (6) LIST OF ACTIVE DEVICES 2pgs
 - (7) SCHEMATIC DIAGRAM 1
 - (8) MANUAL Instruction
 - (9) TUNE-UP/ALIGNMENT PROCEDURE 2pgs
 - (10) CIRCUIT DESCRIPTION 3pgs

BY M.F.A. INC.

- A. TESTIMONIAL & STATEMENT OF CERTIFICATION
- B. STATEMENT OF QUALIFICATIONS
- C. LIST OF TEST INSTRUMENTATION

TOLERANCE (C)	SYMBOL	REVISION NO.	CURD	ISSUED	19
6 ±0.15	△ x -	-	-	-	-
6 ~ 30 ±0.20					
30 ~ 80 ±0.30					
80 ~ 250 ±0.40					
250 ~ 500 ±0.55					

SEE PHOTOS FOR LOCATION OF LABEL AND COMPLIANCE STATEMENT

注記

Notes:

- 印刷ノ詳細ハフィルムニヨリ、色ハ文字、線：黒、地：銀トスル、
For details on printing, refer to the film.
- Colors shall be as follows:
Letters and lines: black
Background: silver
- 粘着剤ニヨル変色ノナキコト、
Pressure-sensitive adhesive must not cause discoloration.
- 納入ハシート状トシ、1シート10枚トスル、
To be delivered on sheets, each sheet containing 10 pcs.

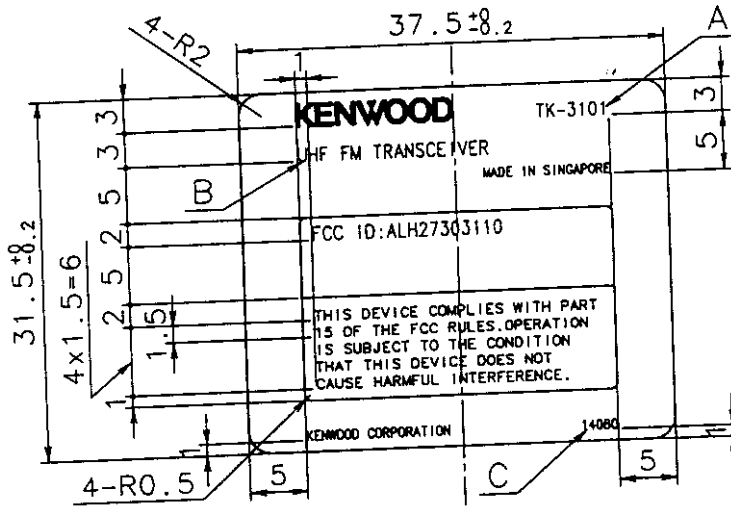

文字 LETTERS	書体 TYPEFACE	天地 HEIGHT
KENWOOD	スタンダード STANDARD	2
TK-3101	ヘルベチカ レギュラー HELVETICA REGULAR	1.75
UHF FM TRANSCEIVER	ヘルベチカ レギュラー HELVETICA REGULAR	1.75
MADE IN SINGAPORE	ヘルベチカ レギュラー HELVETICA REGULAR	1.25
FCC ID: ALH27303110	ヘルベチカ レギュラー HELVETICA REGULAR	1.75
THIS DEVICE COMPLIES WITH PART 15 OF THE FCC RULES. OPERATION IS SUBJECT TO THE CONDITION THAT THIS DEVICE DOES NOT CAUSE HARMFUL INTERFERENCE.	ヘルベチカ レギュラー HELVETICA REGULAR	1.25
KENWOOD CORPORATION	ヘルベチカ レギュラー HELVETICA REGULAR	1.25
14080	ヘルベチカ レギュラー HELVETICA REGULAR	1.25
LINE	ハハ THICKNESS	0.5

DIE LOCATION --- KETS

LOCALLY PURCHASED PARTS

1	B72-1408-04	TK-3101	UHF FM TRANSCEIVER	14080	Y50-4860-10
NO.	PARTS NUMBER	A	B	C	MODEL

		UV印刷 (艶消シ) 強粘着剤 UV PRINTING (FROSTING) STRONG TACKIFIER	Y50-4860-10	-		
NO.	PART NUMBER	NOTE	MATERIAL	FINISH	MODEL	QTY.

SCALE NT: S	DESIGNED	CHECKED	APPROVED	PART NAME	TK-3101
UNIT: mm	JOANNA T. MIURA	LEE CHYAN		MODEL NAME PLATE	
	DATE	1998-07-31		DRAWING NUMBER	B72-1408-04
JIS Z8310-84	KENWOOD	KENWOOD CORPORATION		PART NO.	1/1
				SHEET NO.	00
				REL.	

KENWOOD

KENWOOD COMMUNICATIONS CORPORATION

2201 E. Dominguez St.
Long Beach, CA 90810
Telephone: (310) 633-4200

Mailing Address:
PO Box 22745
Long Beach, CA 90801-5745

May 28, 1996

Federal Communications Commission
Authorization & Evaluation Division
7435 Oakland Mills Road
Columbia, MD 21046

Gentlemen:

Reference:

FCC ID: ALH27303110

This equipment meets the requirements of FCC Rules, Parts 90.203(e) and (g), as applicable.

Programming of this product's transmit frequencies can be performed ONLY by the manufacturer or by service or maintenance personnel. The operator cannot program transmit frequencies using the equipment's external operation controls.

Sincerely,
Kenwood Communications Corporation

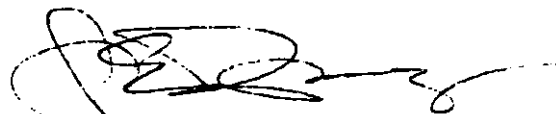

Joel E. Berger
R & D Assistance Manager



M. Flom Associates, Inc. - Global Compliance Center
3356 North San Marcos Place, Suite 107, Chandler, Arizona 85224-1571
www.goodnet.com/~mflom, (602) 926-3100, FAX: 926-3598

Sub-part
2.983 (f):

EQUIPMENT IDENTIFICATION

FCC ID: ALH27303110

NAMEPLATE DRAWING

ATTACHED, EXHIBIT 1.

LOCATION

AS PER LABEL DRAWING(S)

DATE OF REPORT

September 3, 1998

A handwritten signature in black ink that reads 'Morton Flom, P. Eng.' The signature is written in a cursive style with a horizontal line underneath.

Morton Flom, P. Eng.

SUPERVISED BY:

THE APPLICANT HAS BEEN CAUTIONED AS TO THE FOLLOWING:

15.21 INFORMATION TO USER.

The users manual or instruction manual for an intentional radiator shall caution the user that changes or modifications not expressly approved by the party responsible for compliance could void the user's authority to operate the equipment.

15.27(a) SPECIAL ACCESSORIES.

Equipment marketed to a consumer must be capable of complying with the necessary regulations in the configuration in which the equipment is marketed. Where special accessories, such as shielded cables and/or special connectors are required to enable an unintentional or intentional radiator to comply with the emission limits in this part, the equipment must be marketed with, i.e. shipped and sold with, those special accessories. However, in lieu of shipping or packaging the special accessories with the unintentional or intentional radiator, the responsible party may employ other methods of ensuring that the special accessories are provided to the consumer, without additional charge.

Information detailing any alternative method used to supply the special accessories for a grant of equipment authorization or retained in the verification records, as appropriate. The party responsible for the equipment, as detailed in § 2.909 of this chapter, shall ensure that these special accessories are provided with the equipment. The instruction manual for such devices shall include appropriate instructions on the first page of text concerned with the installation of the device that these special accessories must be used with the device. It is the responsibility of the user to use the needed special accessories supplied with the equipment.

TABLE OF CONTENTS

RULE	DESCRIPTION	PAGE
	TEST REPORT	1
2.983	General Information Required	2
2.983	Rule Summary	5
	Standard Test Conditions and Engineering Practices	6
2.985	Carrier Output Power (Conducted)	7
2.991	Unwanted Emissions (Transmitter Conducted)	9
2.993(a)	Field Strength of Spurious Radiation	12
2.993(a)	Field Strength of Spurious Radiation	14
2.989(c) (1)	Emission Masks (Occupied Bandwidth)	18
90.214	Transient Frequency Behavior	22
2.987(a)	Audio Low Pass Filter (Voice Input)	28
2.987(a)	Audio Frequency Response	31
2.987(b)	Modulation Limiting	33
2.995(a) (1)	Frequency Stability (Temperature Variation)	38
2.995(b) (1)	Frequency Stability (Voltage Variation)	41
2.202(g)	Necessary Bandwidth and Emission Bandwidth	42

PAGE NO.

1 of 42.

Required information per ISO/IEC Guide 25-1990, paragraph 13.2:

TEST REPORT

- a)
- b) Laboratory: M. Flom Associates, Inc.
 (FCC: 31040/SIT) 3356 N. San Marcos Place, Suite 107
 (Canada: IC 2044) Chandler, AZ 85224
- c) Report Number: d9890011
- d) Client: Kenwood Communications Corporation
 P.O. Box 22745
 Long Beach, CA 90801-5745
- e) Identification: TK-3101
 Description: FCC ID: ALH27303110
 UHF FM HANDHELD TRANSCEIVER
- f) EUT Condition: Not required unless specified in individual tests.
- g) Report Date: September 3, 1998
 EUT Received: 1998-Sep-02
- h, j, k): As indicated in individual tests.
- i) Sampling method: No sampling procedure used.
- l) Uncertainty: In accordance with MFA internal quality manual.
- m) Supervised by: 
 Morton Flom, P. Eng.
- n) Results: The results presented in this report relate only to the item tested.
- o) Reproduction: This report must not be reproduced, except in full, without written permission from this laboratory.

PAGE NO.

2 of 42.

LIST OF GENERAL INFORMATION REQUIRED FOR TYPE ACCEPTANCEIN ACCORDANCE WITH FCC RULES AND REGULATIONS,
VOLUME II, PART 2 AND TO

22, 74, 80, 90, 95

Sub-part2.983(a): NAME AND ADDRESS OF APPLICANT:Kenwood Communications Corporation
2201 E. Dominguez St
P.O. Box 22745
Long Beach, CA 90801-5745VENDOR:Kenwood Communications Corporation
P.O. Box 22745
Long Beach, CA 90801-57452.983(b): FCC ID: ALH27303110MODEL NO: TK-31012.983(c): QUANTITY PRODUCTION PLANNED.2.983(d): TECHNICAL DESCRIPTION: SEE ATTACHED EXHIBITS(1): TYPE OF EMISSION: 16K0F3E, 11K0F3E(2): FREQUENCY RANGE, MHz: 460 to 470(3): POWER RATING, Watts: 2
Switchable Variable x N/A(4): MAXIMUM POWER RATING, Watts: 300

PAGE NO.

3 of 42.

2.983(d)

(5): VOLTAGES & CURRENTS IN ALL ELEMENTS IN FINAL R. F. STAGE,
INCLUDING FINAL TRANSISTOR OR SOLID STATE DEVICE:

COLLECTOR CURRENT, A = per manual
 COLLECTOR VOLTAGE, Vdc = per manual
 SUPPLY VOLTAGE, Vdc = 7.5

(6): FUNCTION OF ACTIVE CIRCUIT DEVICES:

PLEASE SEE ATTACHED EXHIBITS

(7): CIRCUIT DIAGRAM:

PLEASE SEE ATTACHED EXHIBITS

(8): MANUAL:

PLEASE SEE ATTACHED EXHIBITS

(9): TUNE-UP PROCEDURE:

PLEASE SEE ATTACHED EXHIBITS

(10): DESCRIPTION OF CIRCUITRY & DEVICES PROVIDED FOR
DETERMINING AND STABILIZING FREQUENCY:

PLEASE SEE ATTACHED EXHIBITS

(11): DESCRIPTION OF CIRCUITS OR DEVICES EMPLOYED FOR
 (a) SUPPRESSION OF SPURIOUS RADIATION,
 (b) LIMITING MODULATION,
 (c) LIMITING POWER:

PLEASE SEE ATTACHED EXHIBITS

(12): DIGITAL MODULATION DESCRIPTION:ATTACHED EXHIBITS
N/AX2.983(e): TEST AND MEASUREMENT DATA:

FOLLOWS

2.983(f): LABEL INFORMATION:

PLEASE SEE ATTACHED EXHIBITS

2.983(g): PHOTOGRAPHS:

PLEASE SEE ATTACHED EXHIBITS

PAGE NO.

4 of 42.

PAGE LEFT BLANK

PAGE NO.

5 of 42.

Sub-part
2.983(e):TEST AND MEASUREMENT DATA

All tests and measurement data shown were performed in accordance with FCC Rules and Regulations, Volume II; Part 2, Sub-part J, Sections 2.981, 2.983, 2.985, 2.987, 2.989, 2.991, 2.993, 2.995, 2.997, 2.999 and the following individual Parts:

- _____ 21 - Domestic Public Fixed Radio Services
- x 22 - Public Mobile Services
- _____ 22 Subpart H - Cellular Radiotelephone Service
- _____ 22.901(d) - Alternative technologies and auxiliary services
- _____ 23 - International Fixed Public Radiocommunication services
- _____ 24 - Personal Communications Services
- x 74 Subpart H - Low Power Auxiliary Stations
- x 80 - Stations in the Maritime Services
- _____ 80 Subpart E - General Technical Standards
- _____ 80 Subpart F - Equipment Authorization for Compulsory Ships
- _____ 80 Subpart K - Private Coast Stations and Marine Utility
Stations
- _____ 80 Subpart S - Compulsory Radiotelephone Installations for
Small Passenger Boats
- _____ 80 Subpart T - Radiotelephone Installation Required for
Vessels on the Great Lakes
- _____ 80 Subpart U - Radiotelephone Installations Required by the
Bridge-to-Bridge Act
- _____ 80 Subpart V - Emergency Position Indicating Radiobeacons
(EPIRB'S)
- _____ 80 Subpart W - Global Maritime Distress and Safety System
(GMDSS)
- _____ 80 Subpart X - Voluntary Radio Installations
- _____ 87 - Aviation Services
- x 90 - Private Land Mobile Radio Services
- _____ 94 - Private Operational-Fixed Microwave Service
- x 95 Subpart A - General Mobile Radio Service (GMRS)
- _____ 95 Subpart C - Radio Control (R/C) Radio Service
- _____ 95 Subpart D - Citizens Band (CB) Radio Service
- _____ 95 Subpart E - Family Radio Service
- _____ 95 Subpart F - Interactive Video and Data Service (IVDS)
- _____ 101 - Fixed Microwave Services

PAGE NO.

6 of 42.

STANDARD TEST CONDITIONS
and
ENGINEERING PRACTICES

Except as noted herein, the following conditions and procedures were observed during the testing:

In accordance with ANSI C63.4-1992, section 6.1.9, and unless otherwise indicated in the specific measurement results, the ambient temperature of the actual EUT was maintained within the range of 10° to 40°C (50° to 104 °F) unless the particular equipment requirements specify testing over a different temperature range. Also, unless otherwise indicated, the humidity levels were in the range of 10% to 90% relative humidity.

Prior to testing, the EUT was tuned up in accordance with the manufacturer's alignment procedures. All external gain controls were maintained at the position of maximum and/or optimum gain throughout the testing.

Measurement results, unless otherwise noted, are worst case measurements.

PAGE NO. 7 of 42.
NAME OF TEST: Carrier Output Power (Conducted)
SPECIFICATION: FCC: 47 CFR 2.985(a)
 IC: RSS-119, Section 6.2
GUIDE: TIA/EIA-603, Paragraph 2.2.1
TEST EQUIPMENT: As per attached page

MEASUREMENT PROCEDURE

1. The EUT was connected to a resistive coaxial attenuator of normal load impedance, and the unmodulated output power was measured by means of an R. F. Power Meter.
2. Measurement accuracy is $\pm 3\%$.

MEASUREMENT RESULTS

FREQUENCY OF CARRIER, MHz = 465.05, 460.05, 469.95

POWER SETTING	R. F. POWER, WATTS
HIGH	2

SUPERVISED BY:

 Morton Flom, P. Eng.

TRANSMITTER POWER CONDUCTED MEASUREMENTS

TEST 1: R. F. POWER OUTPUT
 TEST 2: FREQUENCY STABILITY

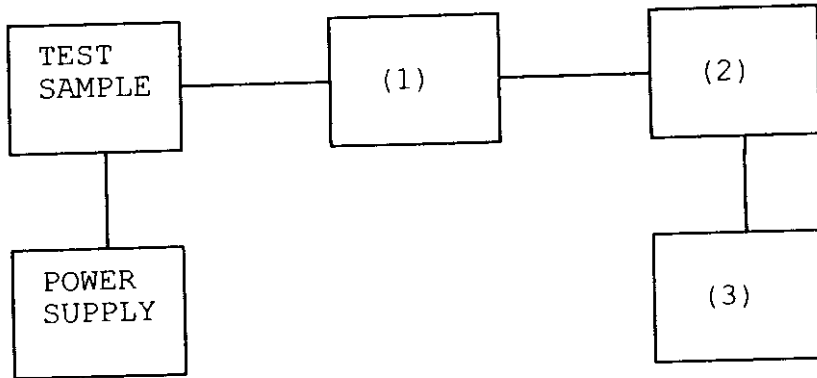

Asset Description

s/n

(1) COAXIAL ATTENUATOR

_____	i00122	Narda 766-10	7802
_____	i00123	Narda 766-10	7802A
_____	i00069	Bird 8329 (30 dB)	1006
<u> x</u>	i00113	Sierra 661A-3D	1059

(2) POWER METERS

_____	i00014	HP 435A	1733A05836
<u> x</u>	i00039	HP 436A	2709A26776
<u> x</u>	i00020	HP 8901A POWER MODE	2105A01087

(3) FREQUENCY COUNTER

_____	i00042	HP 5383A	1628A00959
<u> x</u>	i00019	HP 5334B	2704A00347
<u> x</u>	i00020	HP 8901A FREQUENCY MODE	2105A01087

PAGE NO. 9 of 42.

NAME OF TEST: Unwanted Emissions (Transmitter Conducted)

SPECIFICATION: FCC: 47 CFR 2.991
IC: RSS-119, Section 6.3

GUIDE: TIA/EIA-603, Paragraph 2.2.13

TEST EQUIPMENT: As per attached page

MEASUREMENT PROCEDURE

1. The emissions were measured for the worst case as follows:
 - (a): within a band of frequencies defined by the carrier frequency plus and minus one channel.
 - (b): from the lowest frequency generated in the EUT and to at least the 10th harmonic of the carrier frequency, or 40 GHz, whichever is lower.
2. The magnitude of spurious emissions that are attenuated more than 20 dB below the permissible value need not be specified.

3. MEASUREMENT RESULTS: ATTACHED FOR WORST CASE

FREQUENCY OF CARRIER, MHz	=	465.05, 460.05, 469.95
SPECTRUM SEARCHED, GHz	=	0 to 10 x F _c
MAXIMUM RESPONSE, Hz	=	2510
ALL OTHER EMISSIONS	=	≥ 20 dB BELOW LIMIT
LIMIT(S), dBc		
	-(43+10xLOG P) =	-46 (2 Watts)

SUPERVISED BY:

Morton Flom P. Eng.

Morton Flom, P. Eng.

TRANSMITTER SPURIOUS EMISSION

TEST A. OCCUPIED BANDWIDTH (IN-BAND SPURIOUS)
 TEST B. OUT-OF-BAND SPURIOUS

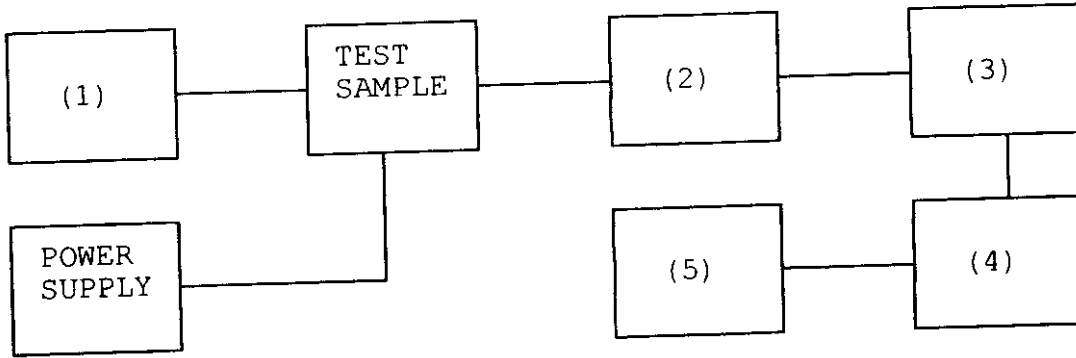

Asset	Description	s/n
(1)	<u>AUDIO OSCILLATOR/GENERATOR</u>	
—	i00010 HP 204D	1105A04683
—	i00017 HP 8903A	2216A01753
<u>x</u>	i00012 HP 3312A	1432A11250
(2)	<u>COAXIAL ATTENUATOR</u>	
—	i00122 Narda 766-10	7802
—	i00123 Narda 766-10	7802A
<u>x</u>	i00069 Bird 8329 (30 dB)	1006
<u>x</u>	i00113 Sierra 661A-3D	1059
(3)	<u>FILTERS; NOTCH, HP, LP, BP</u>	
<u>x</u>	i00126 Eagle TNF-1	100-250
<u>x</u>	i00125 Eagle TNF-1	50-60
<u>x</u>	i00124 Eagle TNF-1	250-850
(4)	<u>SPECTRUM ANALYZER</u>	
<u>x</u>	i00048 HP 8566B	2511A01467
—	i00029 HP 8563E	3213A00104
(5)	<u>SCOPE</u>	
—	i00058 HP 1741A	2251A09356
—	i00030 HP 54502A	2927A00209
—	i00071 Tektronix 935	1935-B011343

PAGE NO.

11 of 42.

NAME OF TEST: Unwanted Emissions (Transmitter Conducted)
 g9890011: 1998-Sep-02 Wed 12:52:00
 STATE: 2:High Power

FREQUENCY TUNED, MHz	FREQUENCY EMISSION, MHz	LEVEL, dBm	LEVEL, dBc	LEVEL, uV
465.050000	929.806000	-43.3	-76.3	0
465.050000	1395.431000	-41.3	-74.3	0
465.050000	1860.655000	-42.2	-75.2	0
465.050000	2325.652000	-41	-74	0
465.050000	2789.857000	-44.1	-77.1	0
465.050000	3255.708000	-43.7	-76.7	0
465.050000	3720.255000	-44.5	-77.5	0
465.050000	4185.202000	-42.1	-75.1	0
465.050000	4650.094000	-43.9	-76.9	0
465.050000	5115.482000	-44.2	-77.2	0
465.050000	5580.468000	-43.8	-76.8	0
465.050000	6045.476000	-38.3	-71.3	0
465.050000	6510.642000	-37.2	-70.2	0
465.050000	6975.526000	-37	-70	0

PAGE NO. 12 of 42.

NAME OF TEST: Field Strength of Spurious Radiation

SPECIFICATION: FCC: 47 CFR 2.993(a)
IC: N/A

GUIDE: TIA/EIA-603, Paragraph 2.2.12

TEST EQUIPMENT: As per attached page

MEASUREMENT PROCEDURE

1. A description of the measurement facilities was filed with the FCC and was found to be in compliance with the requirements of Section 15.38, by letter from the FCC dated March 3, 1997, FILE 31040/SIT. All pertinent changes will be reported to the Commission by up-date prior to March 2000.
2. At first, in order to locate all spurious frequencies and approximate amplitudes, and to determine proper equipment functioning, the test sample was set up at a distance of three meters from the test instrument. Valid spurious signals were determined by switching the power on and off.
3. In the field, the test sample was placed on a wooden turntable above ground at three (or thirty) meters away from the search antenna. The test sample was connected to an R.F. Wattmeter and a 50 ohm dummy load, and adjusted to its rated output.

In order to obtain the maximum response at each spurious frequency, the turntable was rotated. Also, the Search Antennas were raised and lowered vertically, and all cables were oriented. Excess power lead was coiled near the power supply.
4. A signal generator, connected with a non-radiating cable to a vertically polarized half-wave antenna (for each frequency involved) was substituted for the transmitter. The Search Antenna was raised and lowered to obtain maximum indicated.
5. The signal generator output was adjusted until a signal level indication equal to that from the transmitter was obtained.
6. Steps 4 and 5 were repeated, using a horizontally polarized half-wave antenna. The higher of the two observations was noted.

PAGE NO. 13 of 42.
NAME OF TEST: Field Strength of Spurious Radiation
SPECIFICATION: FCC: 47 CFR 2.993(a)
 IC: N/A

MEASUREMENT PROCEDURE (CONT.)

7. Power into the half-wave antenna was calculated from the characteristic impedance of the line, and the voltage output from the signal generator.

8. The level of each spurious radiation with reference to the transmitter power in dB, was calculated from:

$$\text{SPURIOUS LEVEL, dB} = 10 \text{ LOG} \left(\frac{\text{Calculated Spurious Power}}{\text{Tx Power (Wattmeter)}} \right) \text{ [from para. 7].}$$

9. The worst case for all channels is shown.

10. Measurement summary:

FREQUENCY OF CARRIER, MHz	=	465.05, 460.05, 469.95
SPECTRUM SEARCHED, GHz	=	0 to 10 x F _c
MAXIMUM RESPONSE, Hz	=	2510
ALL OTHER EMISSIONS	=	≥ 20 dB BELOW LIMIT
LIMIT(S), dBc	=	-(43+10xLOG P) = -46 (2 Watts)

11. Measurement results: ATTACHED FOR WORST CASE

PAGE NO.

14 of 42.

PAGE LEFT BLANK

RADIATED TEST SETUP

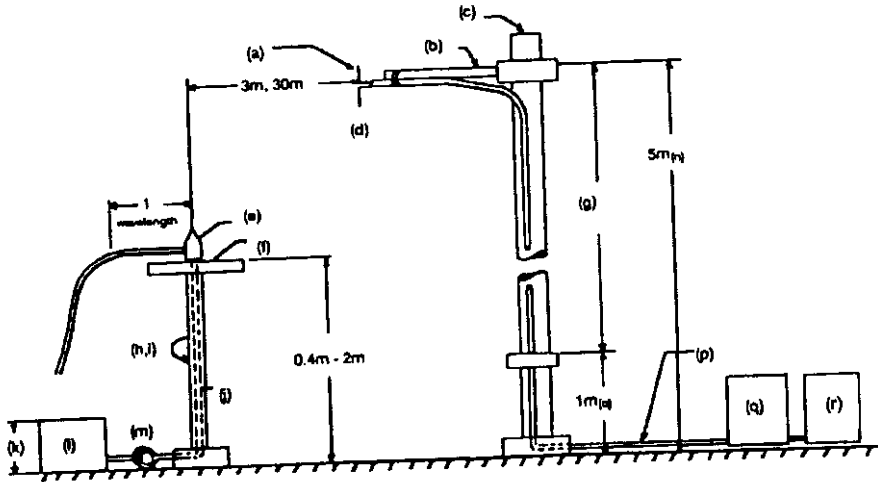

NOTES:

- (a) Search Antenna - Rotatable on boom
- (b) Non-metallic boom
- (c) Non-metallic mast
- (d) Adjustable horizontally
- (e) Equipment Under Test
- (f) Turntable
- (g) Boom adjustable in height.
- (h) External control cables routed horizontally at least one wavelength.
- (i) Rotatable
- (j) Cables routed through hollow turntable center
- (k) 30 cm or less
- (l) External power source
- (m) 10 cm diameter coil of excess cable
- (n) 25 cm (V), 1 m-7 m (V, H)
- (o) 25 cm from bottom end of 'V', 1m normally
- (p) Calibrated Cable at least 10m in length
- (q) Amplifier (optional)
- (r) Spectrum Analyzer

Asset	Description	s/n	Cycle	Last Cal
<u>TRANSDUCER</u>				
—	i00065	EMCO 3109B 100Hz-50MHz	2336	
—	i000	Singer 94593-1 10kHz-32MHz	0219	
—	x i00088	EMCO 3109-B 25MHz-300MHz	2336	
—	x i00089	Apral 2001 200MHz-1GHz	001500	
—	x i00103	EMCO 3115 1GHz-18GHz	9208-3925	
—	i00085	EMCO 3116 10GHz-40GHz	2076	
<u>AMPLIFIER</u>				
—	i00028	HP 8449A	2749A00121	12 month 03/02/98
<u>SPECTRUM ANALYZER</u>				
—	i00029	HP 8563E	3213A00104	12 month 08/25/98
—	x i00033	HP 85462A	3625A00357	12 month 12/23/98
—	i00048	HP 8566B	2511AD1467	12 month 03/19/98

PAGE NO. 16 of 42.

NAME OF TEST: Field Strength of Spurious Radiation

ALL OTHER EMISSIONS = ≥ 20 dB BELOW LIMIT

<u>EMISSION, MHz/HARMONIC</u>	<u>SPURIOUS LEVEL, dBc</u>
2nd to 10th	<-70

SUPERVISED BY:

Morton Flom, P. Eng.

PAGE NO.

17 of 42.

PAGE LEFT BLANK

PAGE NO. 18 of 42.
NAME OF TEST: Emission Masks (Occupied Bandwidth)
SPECIFICATION: FCC: 47 CFR 2.989(c)(1)
IC: RSS-119, Section 6.4
GUIDE: TIA/EIA-603, Paragraph 2.2.11
TEST EQUIPMENT: As per previous page

MEASUREMENT PROCEDURE

1. The EUT and test equipment were set up as shown on the following page, with the Spectrum Analyzer connected.
2. For EUTs supporting audio modulation, the audio signal generator was adjusted to the frequency of maximum response and with output level set for ± 2.5 kHz deviation (or 50% modulation). With level constant, the signal level was increased 16 dB.
3. For EUTs supporting digital modulation, the digital modulation mode was operated to its maximum extent.
4. The Occupied Bandwidth was measured with the Spectrum Analyzer controls set as shown on the test results.
5. MEASUREMENT RESULTS: ATTACHED

PAGE 19 of 42.
SPECTRUM ANALYZER PRESENTATION
KENWOOD, TK-3101
1998-SEP-02, 11:02, WED

POWER: HIGH
MODULATION: NONE

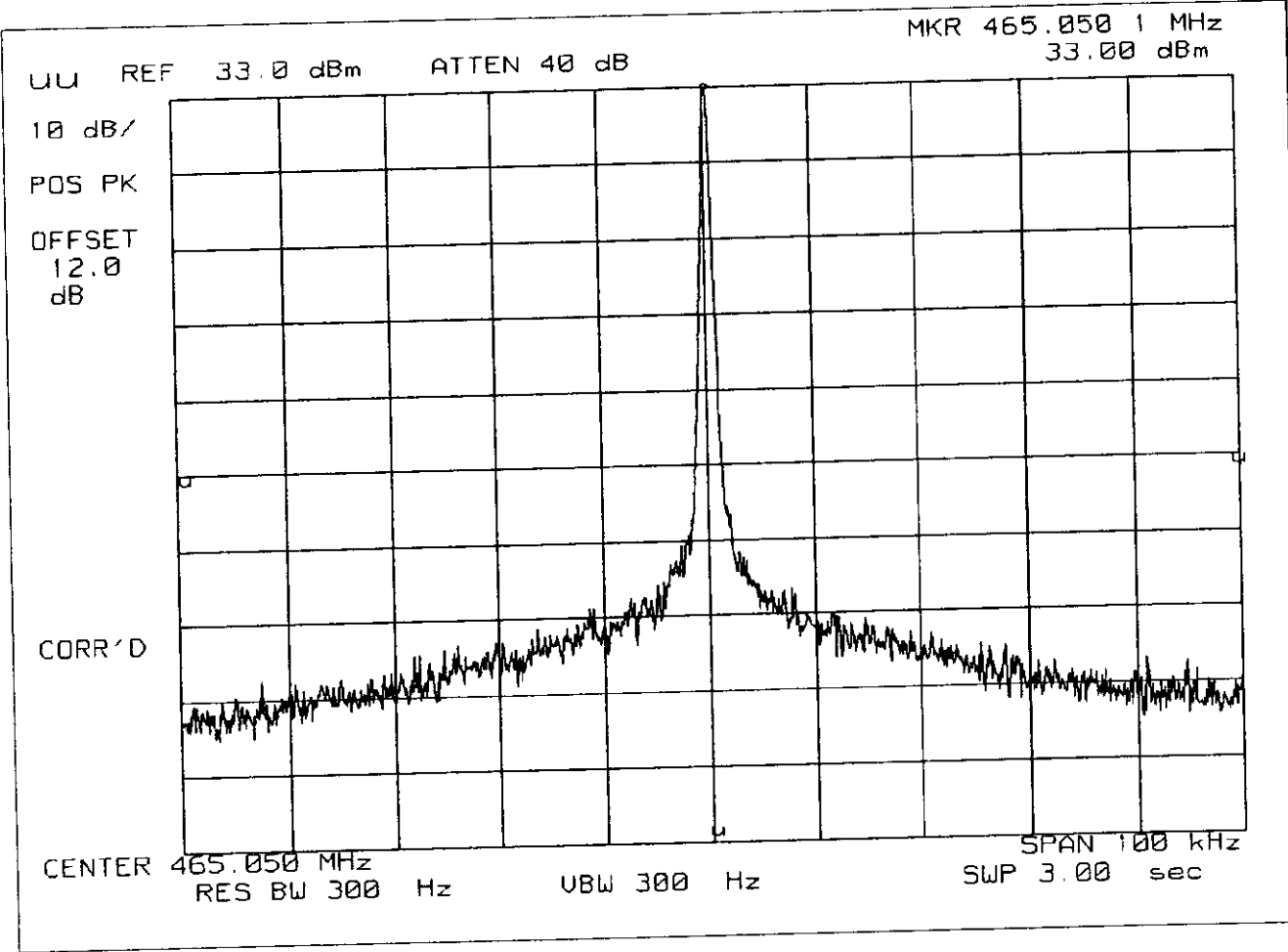

POWER: HIGH
MODULATION: VOICE: 2500 Hz SINE WAVE
MASK: D, VHF/UHF 12.5kHz BW

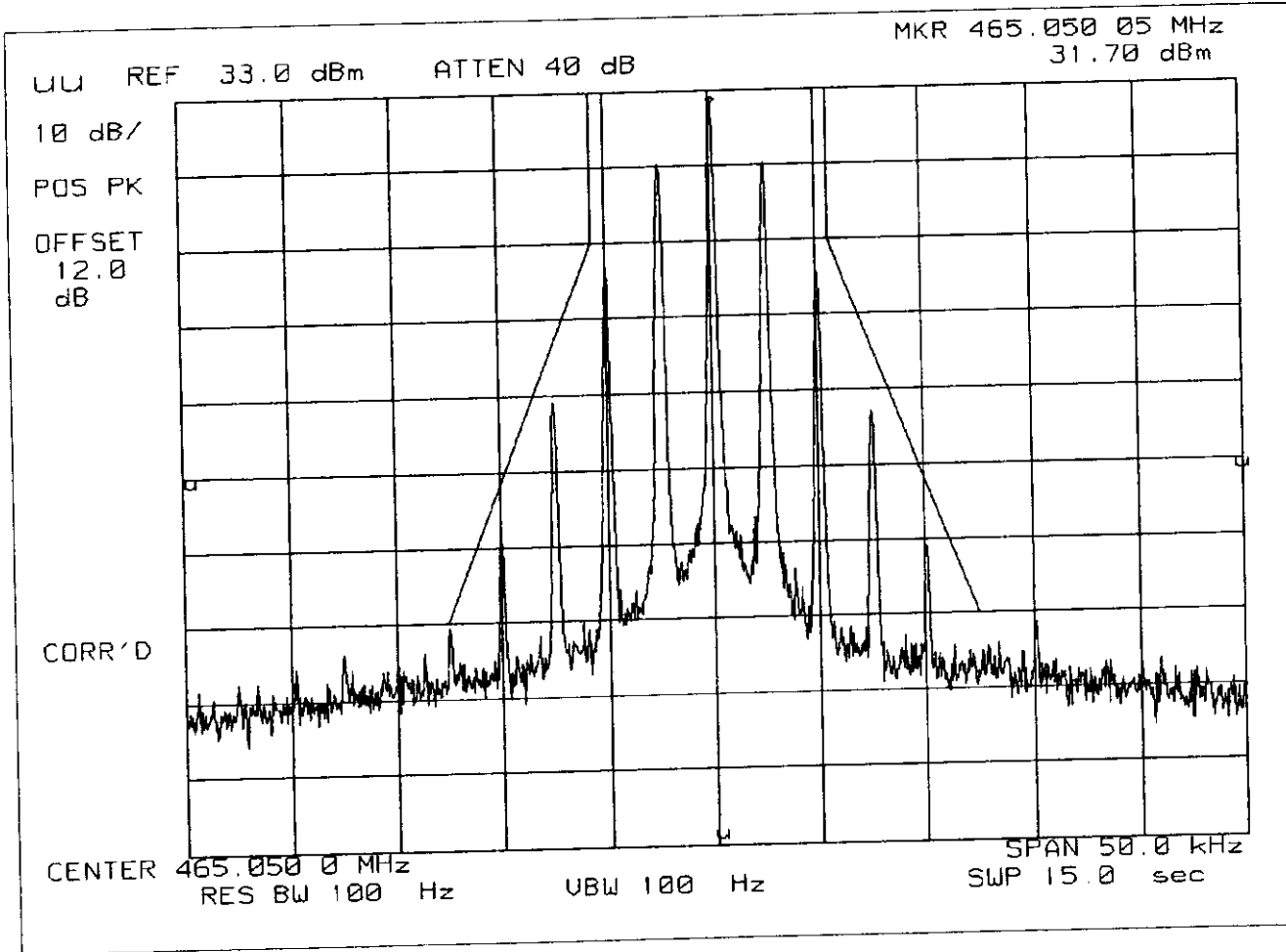

PAGE 21 of 42.
SPECTRUM ANALYZER PRESENTATION
KENWOOD, TK-3101
1998-SEP-02, 11:04, WED

POWER: HIGH
MODULATION: VOICE: 2500 Hz SINE WAVE
MASK: B, VHF/UHF 25kHz, w/LPF

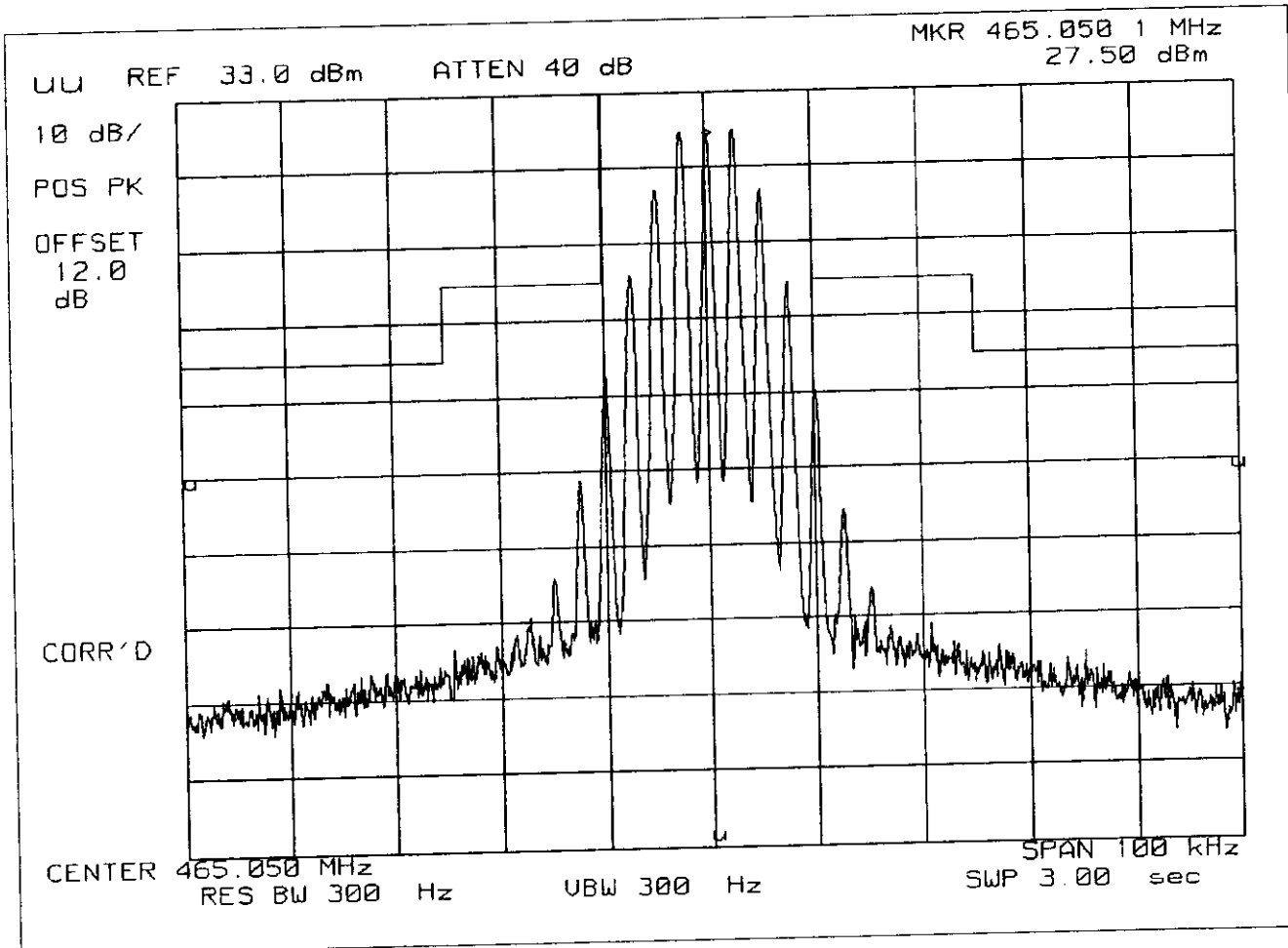

PAGE NO. 22 of 42.

NAME OF TEST: Transient Frequency Behavior

SPECIFICATION: FCC: 47 CFR 90.214
IC: RSS-119, Section 6.5

GUIDE: TIA/EIA-603, Paragraph 2.2.19

TEST EQUIPMENT: As per attached page

MEASUREMENT PROCEDURE

1. The EUT was setup as shown on the attached page, following TIA/EIA-603 steps a, b, and c as a *guide*.
2. The transmitter was turned on.
3. Sufficient attenuation was provided so that the transmitter carrier level measured at the output of the combiner was 40 dB below the maximum input level of the test receiver. This level was recorded as step f.
4. The transmitter was turned off.
5. An R.F signal generator (1) modulated with a 1 kHz tone at either 25, 12.5, or 6.25 kHz deviation, and set to the same frequency as the assigned transmitter frequency, (2) was adjusted to a level -20 dB below the level recorded for step f, as measured at the output of the combiner. This level was then fixed for the remainder of the test and is recorded at step h.
6. The oscilloscope was setup using TIA/EIA-603 steps j and k as a guide, and to either 10 ms/div (UHF) or 5 ms/div (VHF).
7. The 30 dB attenuator was removed, the transmitter was turned on, and the level of the carrier at the output of the combiner was recorded as step l.
8. The carrier on-time as referenced in TIA/EIA-603 steps m, n, and o was captured and plotted. The carrier off-time as referenced in TIA/EIA-603 steps p, q, r, and s was captured and plotted.

LEVELS MEASURED:	
step f, dBm	= -16.2
step h, dBm	= -40.6
step l, dBm	= 9.2

Morton Flom P. Eng.

Morton Flom, P. Eng.

SUPERVISED BY:

TRANSIENT FREQUENCY BEHAVIOR

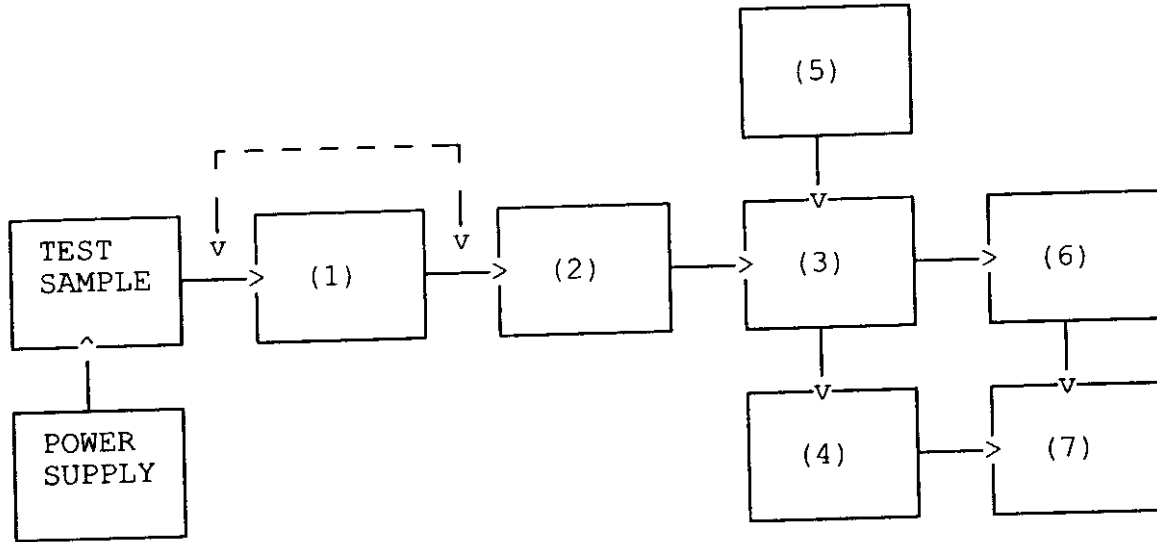

Asset	Description	s/n
(1)	ATTENUATOR (Removed after 1st step)	
x	i00112 Philco 30 dB	989
(2)	ATTENUATOR	
	i00112 Philco 30 dB	989
	i00172 Bird 30 dB	989
x	i00122 Narda 10 dB	7802
	i00123 Narda 10 dB	7802A
	i00110 Kay Variable	145-387
(3)	COMBINER	
x	i00154 4 x 25 Ω COMBINER	154
(4)	CRYSTAL DETECTOR	
x	i00159 HP 8470B	1822A10054
(5)	RF SIGNAL GENERATOR	
	i00018 HP 8656A	2228A03472
	i00031 HP 8656A	2402A06180
x	i00067 HP 8920A	3345U01242
(6)	MODULATION ANALYZER	
x	i00020 HP 8901A	2105A01087
(7)	SCOPE	
x	i00030 HP 54502A	2927A00209

PAGE 24 of 42.
 OSCILLOSCOPE PRESENTATION
 KENWOOD, TK-3101
 1998-SEP-04, 09:03, FRI

MODULATION: Ref Gen=12.5 kHz Deviation
 REMARK: CARRIER ON TIME

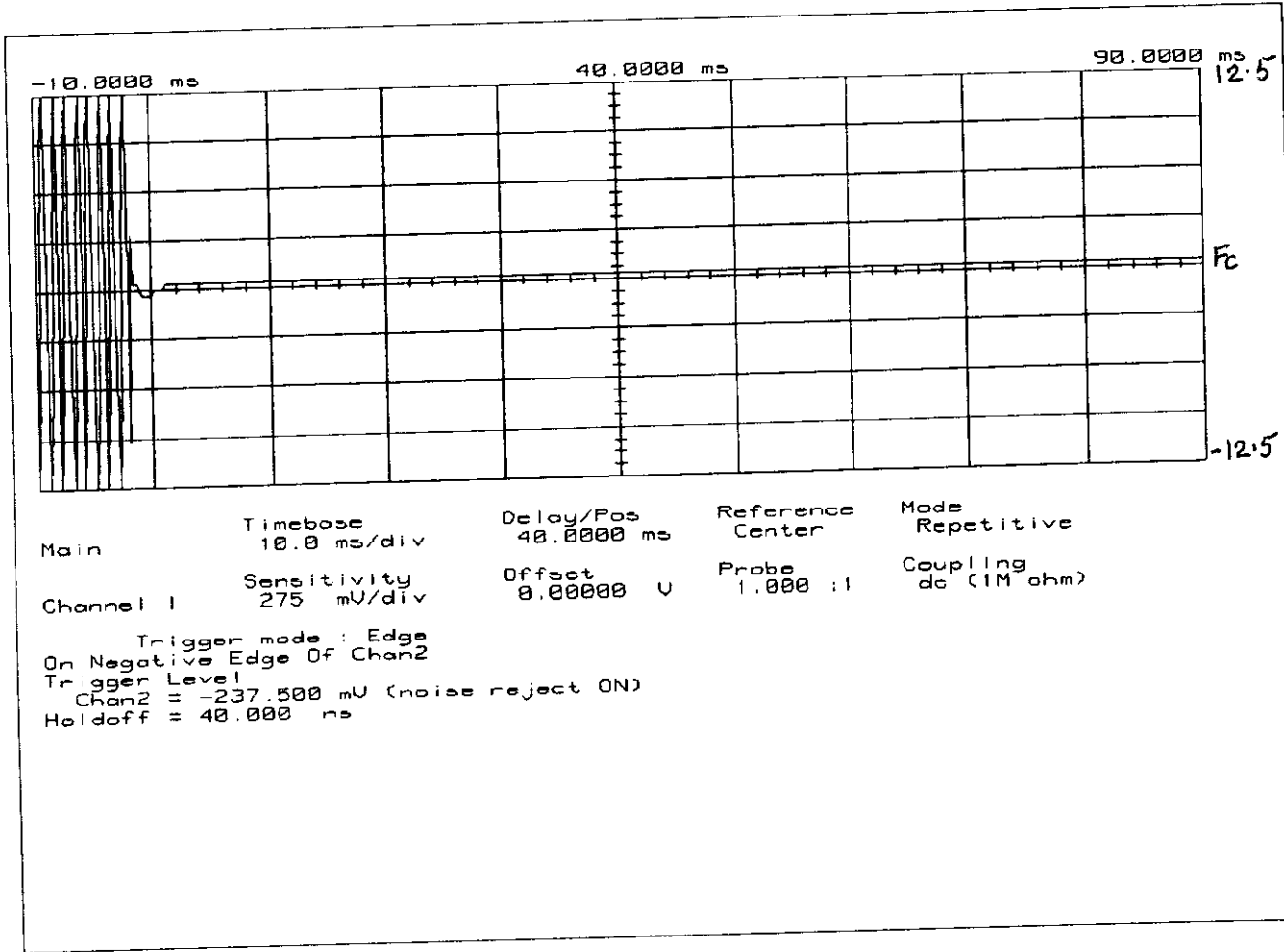

PAGE 25 of 42.
 OSCILLOSCOPE PRESENTATION
 KENWOOD, TK-3101
 1998-SEP-04, 09:07, FRI

MODULATION: Ref Gen=12.5 kHz Deviation
 REMARK: CARRIER OFF TIME

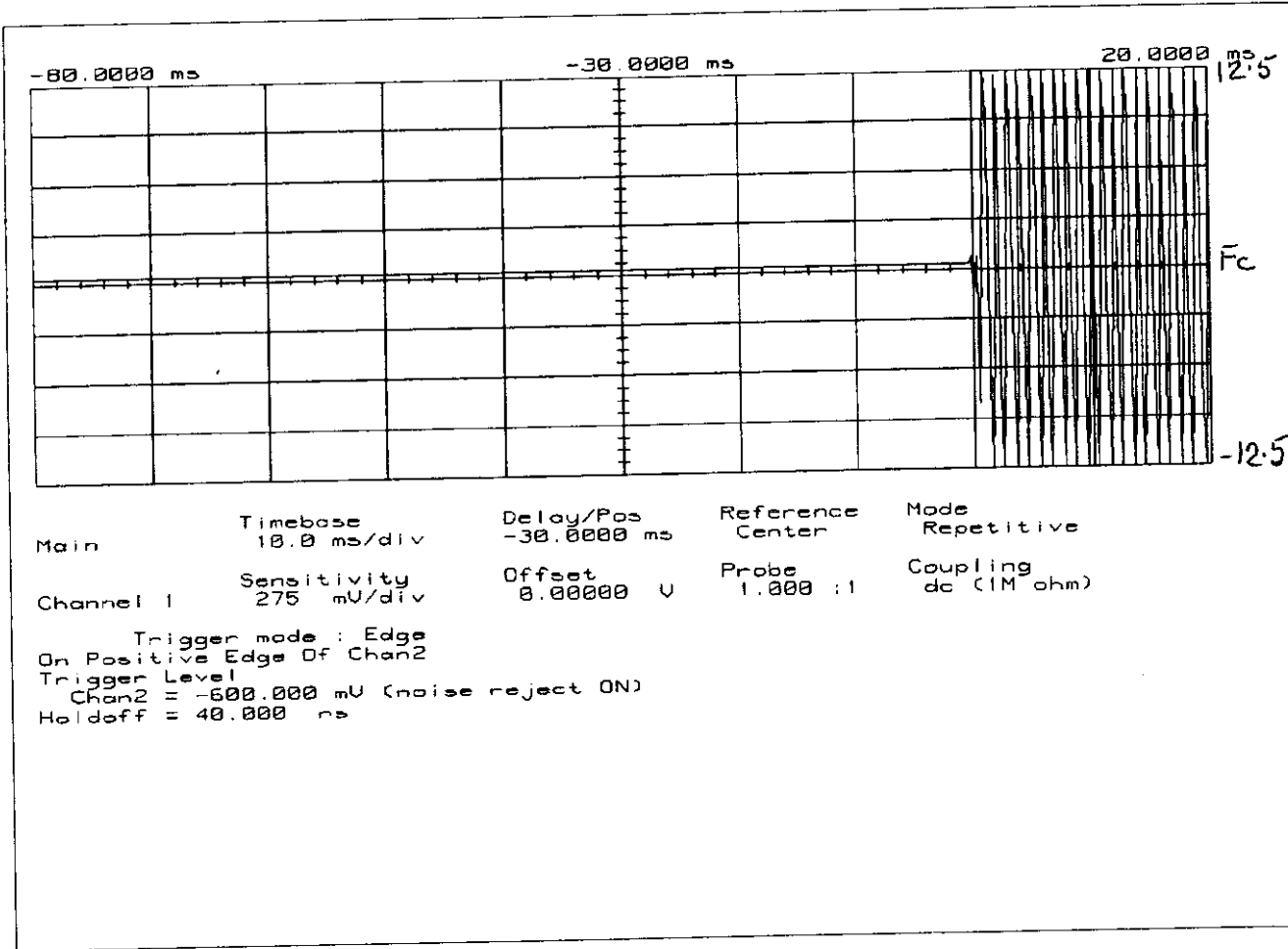

PAGE 26 of 42.
 OSCILLOSCOPE PRESENTATION
 KENWOOD, TK-3101
 1998-SEP-04, 08:51, FRI

MODULATION: Ref Gen=25 kHz Deviation
 REMARK: CARRIER ON TIME

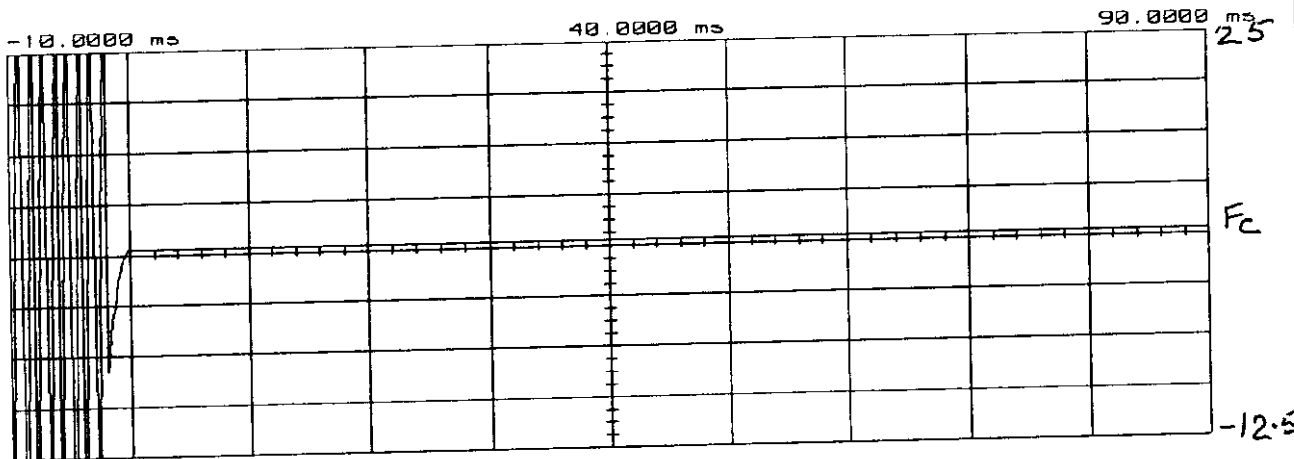

Main	Timebase 10.0 ms/div	Delay/Pos 40.0000 ms	Reference Center	Mode Repetitive
Channel 1	Sensitivity 275 mV/div	Offset 0.00000 V	Probe 1.000 :1	Coupling dc (1M ohm)

Trigger mode : Edge
 On Negative Edge Of Chan2
 Trigger Level
 Chan2 = -237.500 mV (noise reject ON)
 Holdoff = 40.000 ns

C:\VLOS\TRACES\08090408.PCT COPYRIGHT © 1998 BY N. FLOP ASSOCIATES, INC. ALL RIGHTS RESERVED

PAGE 27 of 42.
 OSCILLOSCOPE PRESENTATION
 KENWOOD, TK-3101
 1998-SEP-04, 08:52, FRI

MODULATION: Ref Gen=25 kHz Deviation
 REMARK: CARRIER OFF TIME

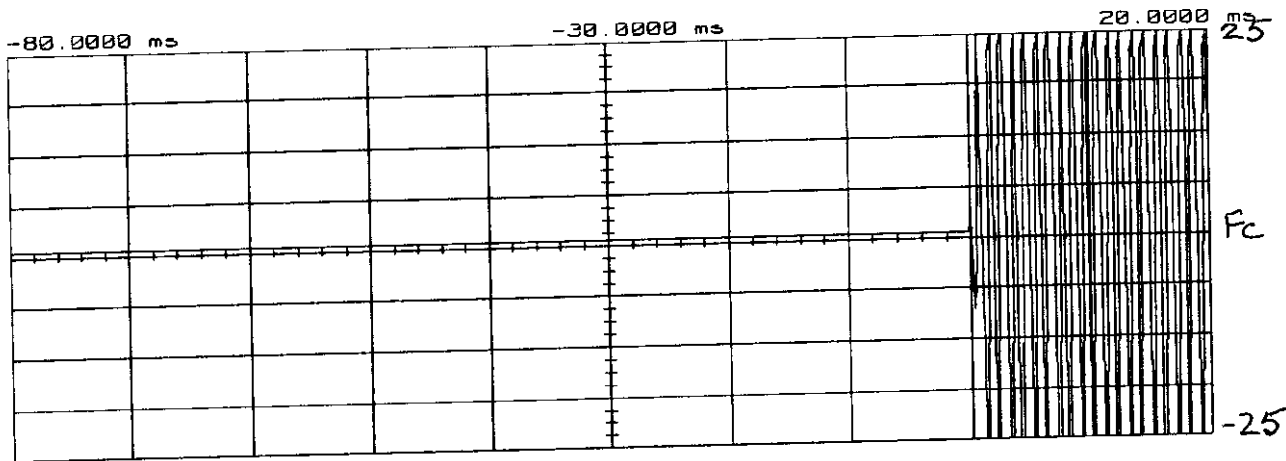

Main	Timebase 10.0 ms/div	Delay/Pos -30.0000 ms	Reference Center	Mode Repetitive
Channel 1	Sensitivity 275 mV/div	Offset 0.00000 V	Probe 1.000 :1	Coupling dc (1M ohm)

Trigger mode : Edge
 On Positive Edge Of Chan2
 Trigger Level
 Chan2 = -600.000 mV (noise reject ON)
 Holdoff = 40.000 ns

CALISTO TRACE 18884881.PLY COPYRIGHT (C) 1998 BY H. FLUOR ASSOCIATES, INC. ALL RIGHTS RESERVED

PAGE NO. 28 of 42.
NAME OF TEST: Audio Low Pass Filter (Voice Input)
SPECIFICATION: FCC: 47 CFR 2.987(a)
IC: RSS-119, Section 6.6
GUIDE: TIA/EIA-603, Paragraph 2.2.15
TEST EQUIPMENT: As per attached page

MEASUREMENT PROCEDURE

1. The EUT and test equipment were set up such that the audio input was connected at the input to the modulation limit, and the modulated stage.
2. The audio output was connected at the output to the modulated stage.
3. MEASUREMENT RESULTS: ATTACHED

TRANSMITTER TEST SET-UP

- TEST A. MODULATION CAPABILITY/DISTORTION
- TEST B. AUDIO FREQUENCY RESPONSE
- TEST C. HUM AND NOISE LEVEL
- TEST D. RESPONSE OF LOW PASS FILTER
- TEST E. MODULATION LIMITING

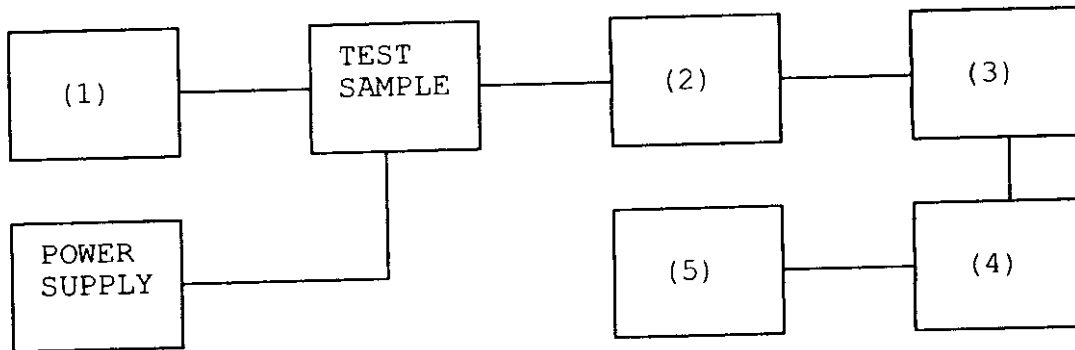

Asset	Description	s/n
<u>(1) LINE IMPEDANCE STABILIZATION NETWORK</u>		
	i00010 HP 204D	1105A04683
x	i00017 HP 8903A	2216A01753
x	i00118 HP 33120A	US36002064
<u>(2) COAXIAL ATTENUATOR</u>		
	i00122 NARDA 766-10	7802
	i00123 NARDA 766-10	7802A
x	i00113 SIERRA 661A-3D	1059
	i00069 BIRD 8329 (30 dB)	10066
<u>(3) MODULATION ANALYZER</u>		
x	i00020 HP 8901A	2105A01087
<u>(4) AUDIO ANALYZER</u>		
x	i00017 HP 8903A	2216A01753
<u>(5) SCOPE</u>		
	i00058 HP 1741A	2215A09356
	i00071 Tektronix 935	1935-B011343

FREQUENCY RESPONSE OF AUDIO LOW PASS FILTER
KENWOOD, TK-3101
3 SEP 1998, 08:27

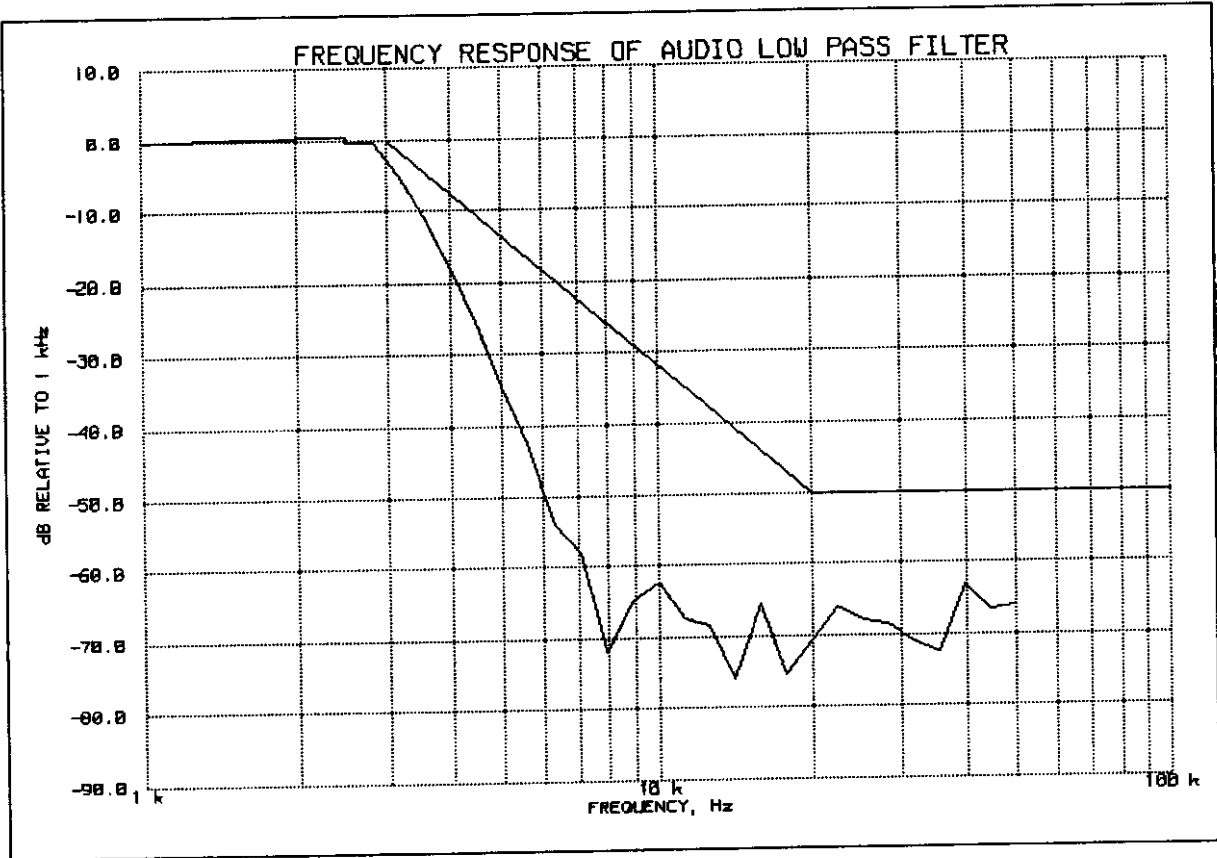

COPYRIGHT (C) 1988 BY H. FLOM ASSOCIATES, INC. ALL RIGHTS RESERVED.

PEAK AUDIO FREQUENCY, Hz: 2500

Morton P. Eng

SUPERVISED BY:

MORTON FLOM, P. Eng.

PAGE NO. 31 of 42.
NAME OF TEST: Audio Frequency Response
SPECIFICATION: FCC: 47 CFR 2.987(a)
IC: N/A
GUIDE: TIA/EIA-603, Paragraph 2.2.6
TEST EQUIPMENT: As per previous page

MEASUREMENT PROCEDURE

1. The EUT and test equipment were set up as shown on the following page.
2. The audio signal generator was connected to the audio input circuit/microphone of the EUT.
3. The audio signal input was adjusted to obtain 20% modulation at 1 kHz, and this point was taken as the 0 dB reference level.
4. With input levels held constant and below limiting at all frequencies, the audio signal generator was varied from 100 Hz to 50 kHz.
5. The response in dB relative to 1 kHz was then measured, using the HP 8901A Modulation Analyzer.
6. MEASUREMENT RESULTS: ATTACHED

TRANSMITTER AUDIO FREQUENCY RESPONSE
 KENWOOD, TK-3101
 2 SEP 1998, 09:54

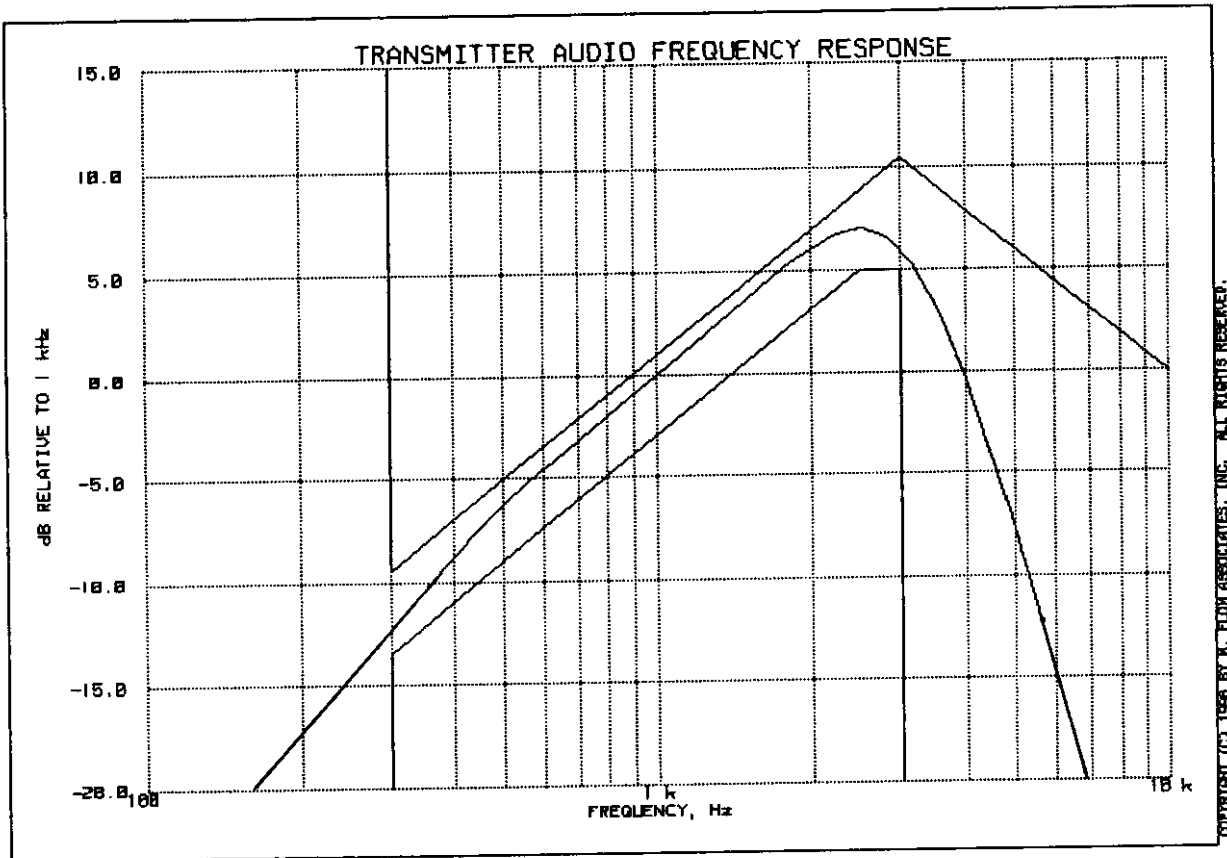

PEAK AUDIO FREQUENCY, Hz: 2510

TABLE VALUES:

FREQUENCY, Hz	LEVEL, dB	FREQUENCY, Hz	LEVEL, dB	FREQUENCY, Hz	LEVEL, dB
300	-12.7	30000	-21.2		
20000	-20.7	50000	-21.8		

Morton Flom P. Eng.

MORTON FLOM, P. Eng.

SUPERVISED BY:

PAGE NO. 33 of 42.
NAME OF TEST: Modulation Limiting
SPECIFICATION: FCC: 47 CFR 2.987(b)
IC: RSS-119, Section 6.6
GUIDE: TIA/EIA-603, Paragraph 2.2.3
TEST EQUIPMENT: As per previous page

MEASUREMENT PROCEDURE

1. The signal generator was connected to the input of the EUT as for "Frequency Response of the Modulating Circuit."
2. The modulation response was measured for each of three frequencies (one of which was the frequency of maximum response), and the input voltage was varied and was observed on an HP 8901A Modulation Analyzer.
3. The input level was varied from 30% modulation (± 1.5 kHz deviation) to at least 20 dB higher than the saturation point.
4. Measurements were performed for both negative and positive modulation and the respective results were recorded.
5. MEASUREMENT RESULTS: ATTACHED

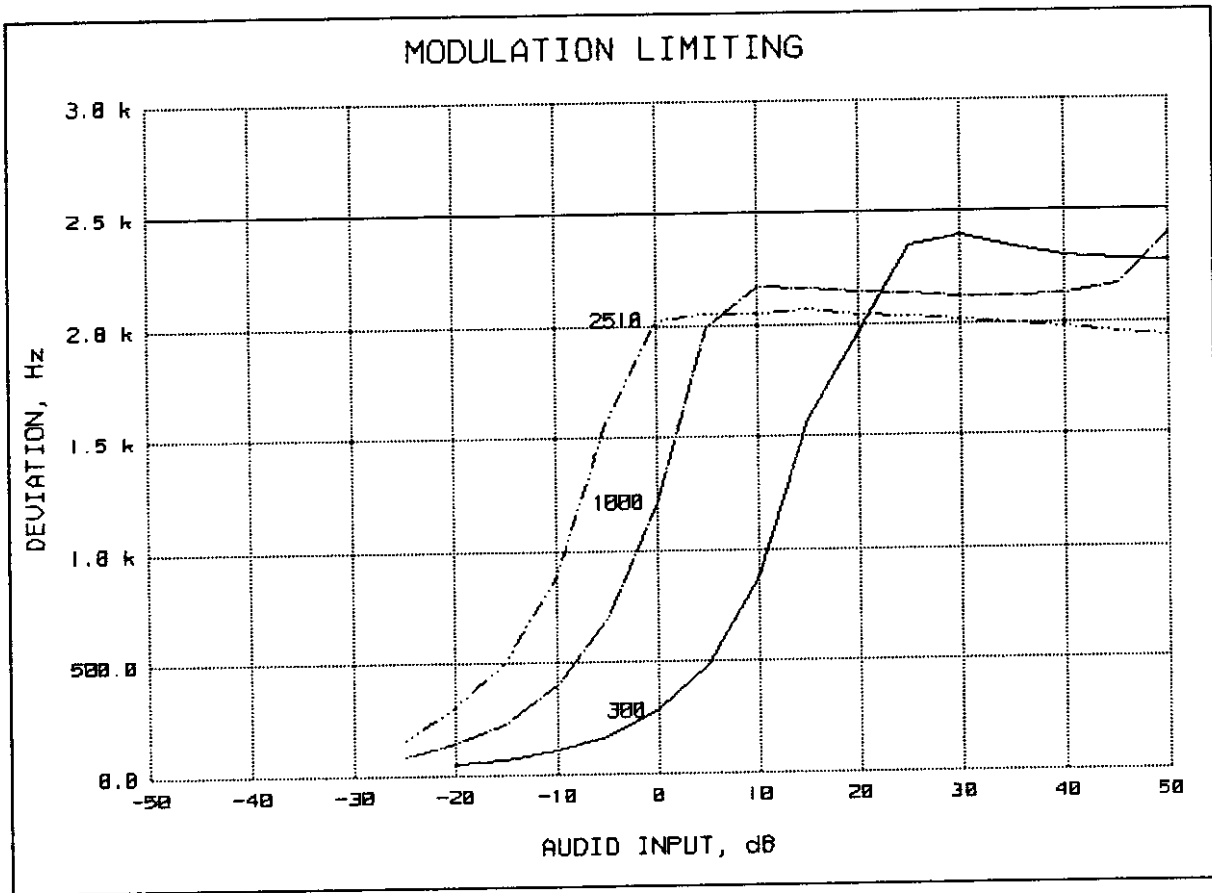

COPYRIGHT © 1998 BY W. FLOR ASSOCIATES, INC. ALL RIGHTS RESERVED.

REFERENCE DEVIATION, kHz = 1.25
 REFERENCE MODULATION, Hz = 1000
 PEAKS = NEGATIVE
 AUDIO AMPLITUDE, mV = 15.28

Morton F. Eng.

SUPERVISED BY:

MORTON FLOM, P. Eng.

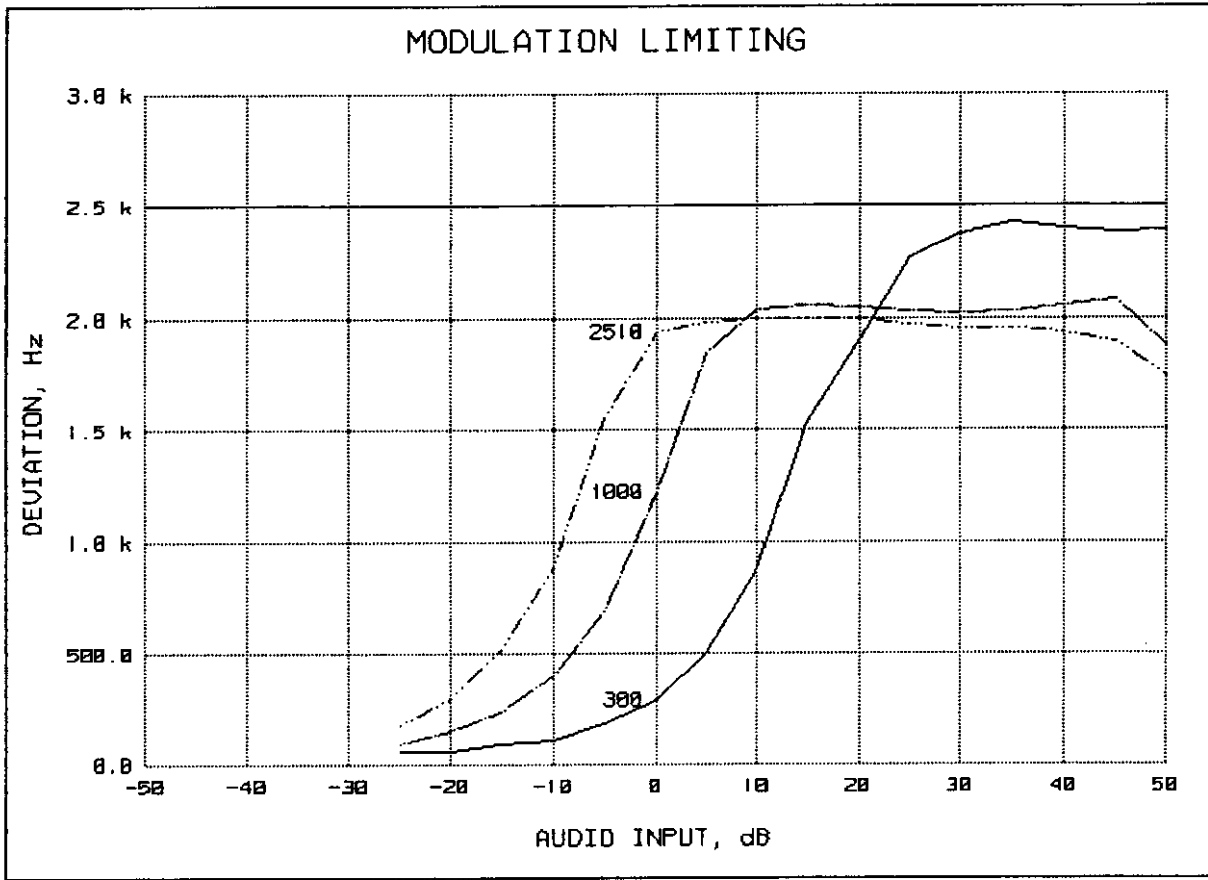

REFERENCE DEVIATION, kHz = 1.25
REFERENCE MODULATION, Hz = 1000
PEAKS = POSITIVE
AUDIO AMPLITUDE, mV = 15.28

Morton P. Eng.

SUPERVISED BY:

MORTON FLOM, P. Eng.

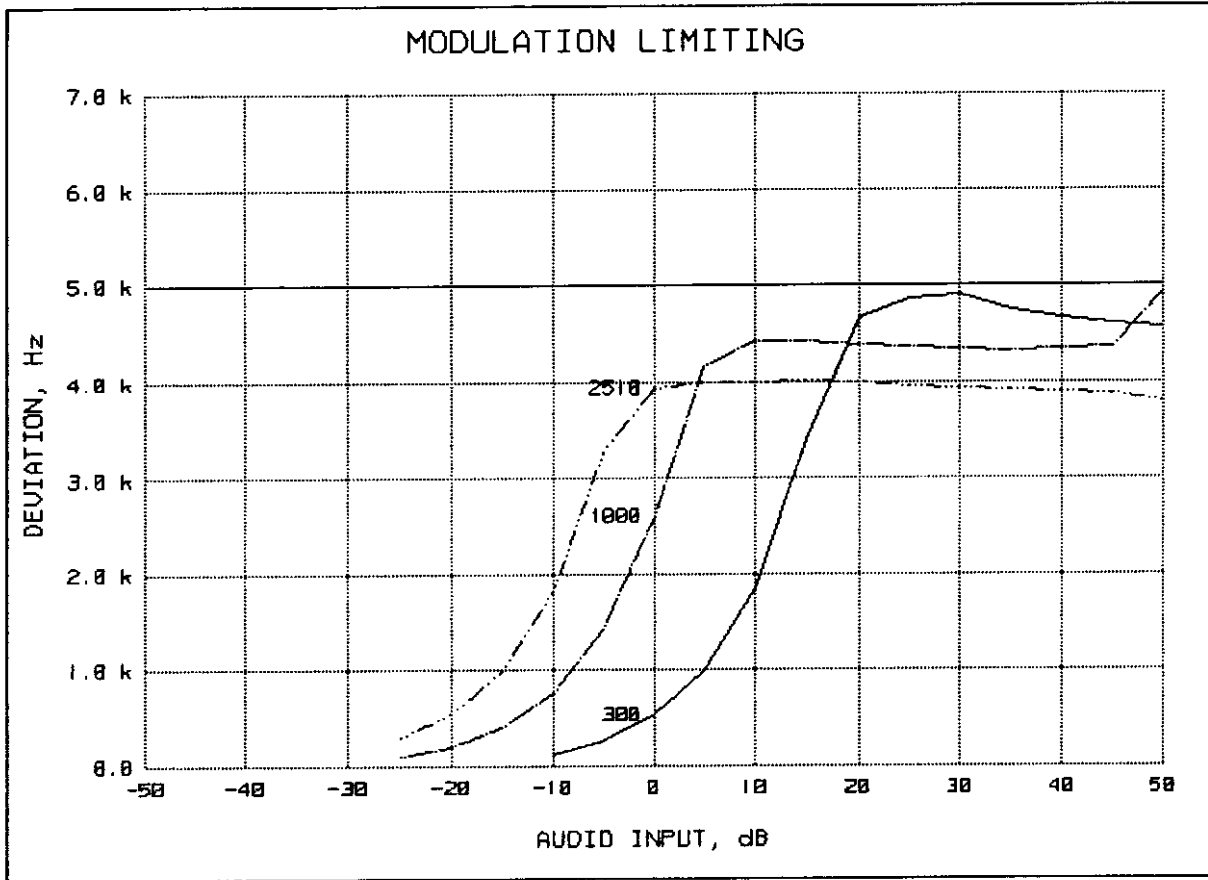

REFERENCE DEVIATION, kHz = 2.55
REFERENCE MODULATION, Hz = 1000
PEAKS = NEGATIVE
AUDIO AMPLITUDE, mV = 16.18

Morton Flom P. Eng.

SUPERVISED BY:

MORTON FLOM, P. Eng.

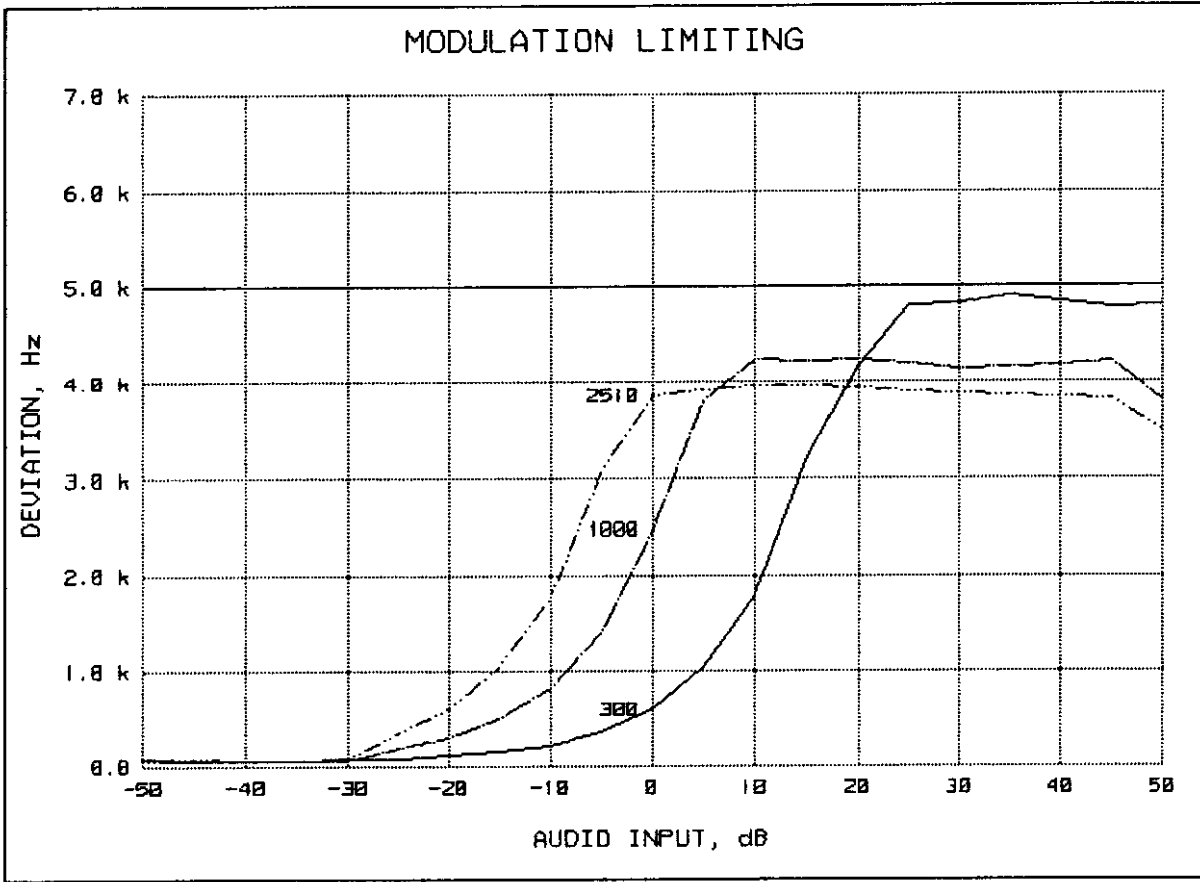

REFERENCE DEVIATION, kHz = 2.55
REFERENCE MODULATION, Hz = 1000
PEAKS = POSITIVE
AUDIO AMPLITUDE, mV = 15.28

M. Flom P. Eng.

SUPERVISED BY:

MORTON FLOM, P. Eng.

PAGE NO. 38 of 42.

NAME OF TEST: Frequency Stability (Temperature Variation)

SPECIFICATION: FCC: 47 CFR 2.995(a)(1)
IC: RSS-119, Section 7.0

GUIDE: TIA/EIA-603, Paragraph 2.2.2

TEST CONDITIONS: As Indicated

TEST EQUIPMENT: As per previous page

MEASUREMENT PROCEDURE

1. The EUT and test equipment were set up as shown on the following page.
2. With all power removed, the temperature was decreased to -30°C and permitted to stabilize for three hours. Power was applied and the maximum change in frequency was noted within one minute.
3. With power OFF, the temperature was raised in 10°C steps. The sample was permitted to stabilize at each step for at least one-half hour. Power was applied and the maximum frequency change was noted within one minute.
4. The temperature tests were performed for the worst case.
5. MEASUREMENT RESULTS: ATTACHED

TRANSMITTER TEST SET-UP

- TEST A. OPERATIONAL STABILITY
- TEST B. CARRIER FREQUENCY STABILITY
- TEST C. OPERATIONAL PERFORMANCE STABILITY
- TEST D. HUMIDITY
- TEST E. VIBRATION
- TEST F. ENVIRONMENTAL TEMPERATURE
- TEST G. FREQUENCY STABILITY: TEMPERATURE VARIATION
- TEST H. FREQUENCY STABILITY: VOLTAGE VARIATION

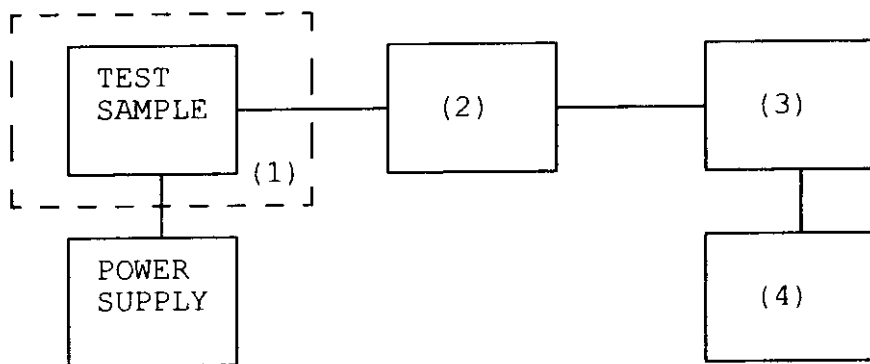

Asset Description s/n

(1) TEMPERATURE, HUMIDITY, VIBRATION

<u>x</u>	i00027	Tenny Temp. Chamber	9083-765-234
---	i00	Weber Humidity Chamber	
---	i00	L.A.B. RVH 18-100	

(2) COAXIAL ATTENUATOR

---	i00122	NARDA 766-10	7802
---	i00123	NARDA 766-10	7802A
<u>x</u>	i00113	SIERRA 661A-3D	1059
---	i00069	BIRD 8329 (30 dB)	10066

(3) R.F. POWER

---	i00014	HP 435A POWER METER	1733A05839
<u>x</u>	i00039	HP 436A POWER METER	2709A26776
<u>x</u>	i00020	HP 8901A POWER MODE	2105A01087

(4) FREQUENCY COUNTER

---	i00042	HP 5383A	1628A00959
<u>x</u>	i00019	HP 5334B	2704A00347
<u>x</u>	i00020	HP 8901A	2105A01087

TRANSMITTER FREQUENCY STABILITY
KENWOOD, TK-3101
2 SEP 1998, 14:42

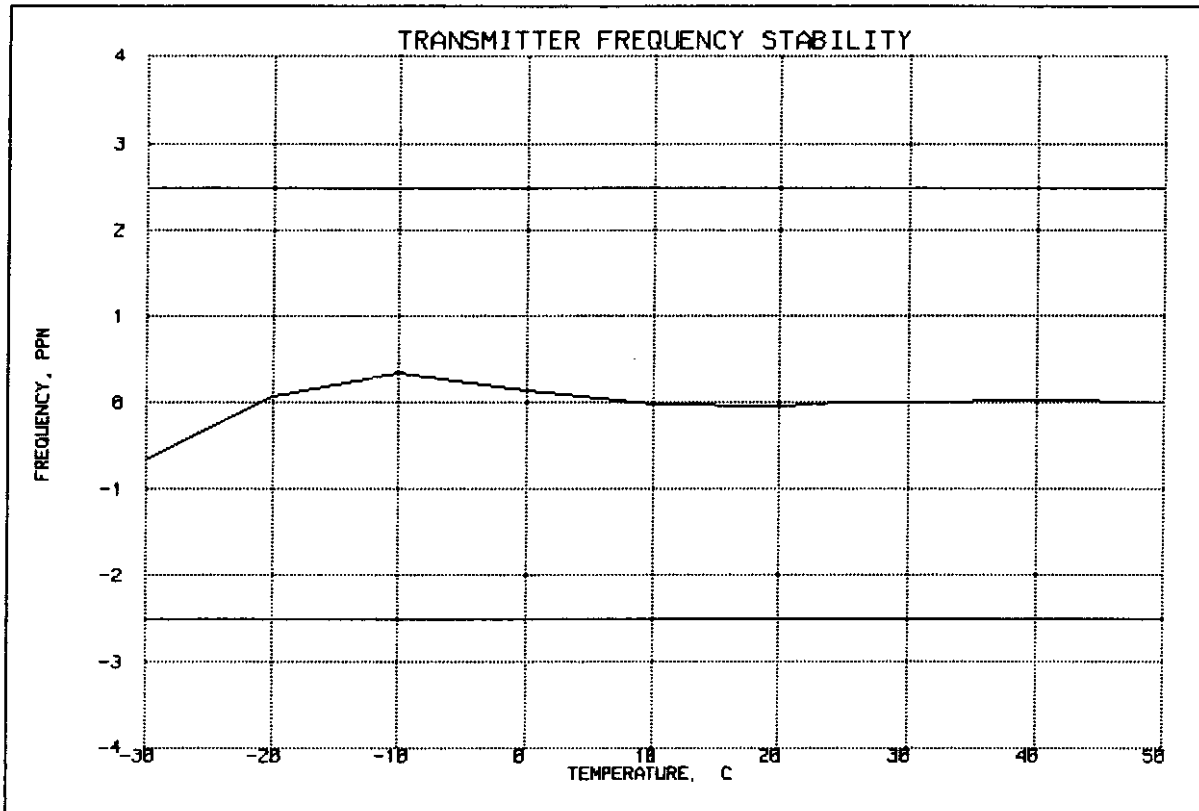

COPYRIGHT (C) 1998 BY N. FLOM ASSOCIATES, INC. ALL RIGHTS RESERVED.

FREQUENCY OF CARRIER, MHz = 465.05009

LIMIT, ppm = 2.5

LIMIT, Hz = 1163

SUPERVISED BY:

MORTON FLOM, P. Eng.

PAGE NO. 41 of 42.

NAME OF TEST: Frequency Stability (Voltage Variation)

SPECIFICATION: FCC: 47 CFR 2.995 (b) (1)
IC: RSS-119, Section 7.0

GUIDE: TIA/EIA-603, Paragraph 2.2.2

TEST EQUIPMENT: As per previous page

MEASUREMENT PROCEDURE

1. The EUT was placed in a temperature chamber at 25±5°C and connected as for "Frequency Stability - Temperature Variation" test.
2. The power supply voltage to the EUT was varied from 85% to 115% of the nominal value measured at the input to the EUT.
3. The variation in frequency was measured for the worst case.

RESULTS: Frequency Stability (Voltage Variation)
g9890006: 1998-Sep-02 Wed 10:30:54
STATE: 0:General

LIMIT, ppm = 2.5
LIMIT, Hz = 1163
BATTERY END POINT (Voltage) = 6

% of STV	Voltage	Frequency, MHz	Change, Hz	Change, ppm
85	6.37	460.050000	0	0.00
100	7.5	460.050000	0	0.00
115	8.62	460.050010	10	0.02
80	6	460.050000	0	0.00

SUPERVISED BY:

Morton Flom P. Eng.

Morton Flom, P. Eng.

PAGE NO. 42 of 42.
NAME OF TEST: Necessary Bandwidth and Emission Bandwidth
SPECIFICATION: FCC: 47 CFR 2.202 (g)
IC: N/A

MODULATION = 16K0F3E
NECESSARY BANDWIDTH CALCULATION:
MAXIMUM MODULATION (M), kHz = 3
MAXIMUM DEVIATION (D), kHz = 5
CONSTANT FACTOR (K) = 1
NECESSARY BANDWIDTH (B_N), kHz = 16K0

MODULATION = 11K0F3E
NECESSARY BANDWIDTH CALCULATION:
MAXIMUM MODULATION (M), kHz = 3
MAXIMUM DEVIATION (D), kHz = 2.5
CONSTANT FACTOR (K) = 1
NECESSARY BANDWIDTH (B_N), kHz = 11K0

SUPERVISED BY:
END OF TEST REPORT

Morton Flom, P. Eng.

TESTIMONIAL
AND
STATEMENT OF CERTIFICATION

THIS IS TO CERTIFY THAT:

1. THAT the application was prepared either by, or under the direct supervision of, the undersigned.
2. THAT the technical data supplied with the application was taken under my direction and supervision.
3. THAT the data was obtained on representative units, randomly selected.
4. THAT, to the best of my knowledge and belief, the facts set forth in the application and accompanying technical data are true and correct.

CERTIFYING ENGINEER:

Morton Flom, P. Eng.

STATEMENT OF QUALIFICATIONS

EDUCATION:

1. B. ENG. in ENGINEERING PHYSICS, 1949, McGill University, Montreal, Canada.
2. Post Graduate Studies, McGill University & Sir George Williams University, Montreal.

PROFESSIONAL AFFILIATIONS:

1. ARIZONA SOCIETY OF PROFESSIONAL ENGINEERS (NSPE), #026 031 821.
2. ORDER OF ENGINEERS (QUEBEC) 1949. #4534.
3. ASSOCIATION OF PROFESSIONAL ENGINEERS, GEOPHYSICISTS & GEOLOGISTS OF ALBERTA #5916.
4. REGISTERED ENGINEERING CONSULTANT - GOVERNMENT OF CANADA, DEPARTMENT OF COMMUNICATIONS. Radio Equipment Approvals.
5. IEEE, Lifetime Member No. 0417204 (member since 1947).

EXPERIENCE:

1. Research/Development/Senior Project Engineer, R.C.A. LIMITED (4 years).
2. Owner/Chief Engineer of Electronics. Design/Manufacturing & Cable TV Companies (10 years).
3. CONSULTING ENGINEER (over 25 years).

MORTON FLOM, P. Eng.