

PAGE NO. 1 of 29.

Required information per ISO/IEC Guide 25-1990, paragraph 13.2:

TEST REPORT

- a)
- b) Laboratory: M. Flom Associates, Inc.
(FCC: 31040/SIT) 3356 N. San Marcos Place, Suite 107
(Canada: IC 2044) Chandler, AZ 85224
- c) Report Number: d98a0060
- d) Client: Kenwood Communications Corporation
P.O. Box 22745
Long Beach, CA 90801-5745
- e) Identification: TK-480
Description: FCC ID: ALH22961110
UHF FM Handheld Transmitter
- f) EUT Condition: Not required unless specified in individual tests.
- g) Report Date: October 26, 1998
EUT Received: October 21, 1998
- h, j, k): As indicated in individual tests.
- i) Sampling method: No sampling procedure used.
- l) Uncertainty: In accordance with MFA internal quality manual.
- m) Supervised by: 
Morton Flom, P. Eng.
- n) Results: The results presented in this report relate only to the item tested.
- o) Reproduction: This report must not be reproduced, except in full, without written permission from this laboratory.

PAGE NO.

2 of 29.

EXPOSITORY STATEMENT
PERMISSIVE CHANGE

APPLICANT: Kenwood Communications Corporation

FCC ID: ALH22961110

The applicant has made design changes/improvements to the originally FCC approved equipment.

Data contained herein confirms that a Permissive Change to the unit has been effected and that the performance of the unit is at or better than the levels originally reported to the commission.

A copy of the original grant of equipment approval is included for convenience.

The following changes/improvements have been made:

Software Change to \pm 4.0 khz Deviation

PAGE NO. 3 of 29.

LIST OF GENERAL INFORMATION REQUIRED FOR CERTIFICATION

IN ACCORDANCE WITH FCC RULES AND REGULATIONS,
VOLUME II, PART 2 AND TO

90

Sub-part 2.1033

(c) (1): NAME AND ADDRESS OF APPLICANT:

Kenwood Communications Corporation
2201 E. Dominguez St
P.O. Box 22745
Long Beach, CA 90801-5745

VENDOR:

Kenwood Communications Corporation
P.O. Box 22745
Long Beach, CA 90801-5745

(c) (2): FCC ID: ALH22961110

MODEL NO: TK-480

(c) (3): INSTRUCTION MANUAL(S):

PLEASE SEE ATTACHED EXHIBITS

(c) (4): TYPE OF EMISSION: 14K0F3E
16K0F3E

(c) (5): FREQUENCY RANGE, MHz: 806 to 825
851 to 874

(c) (6): POWER RATING, Watts: 1 to 2.5
x Switchable ___ Variable ___ N/A

(c) (7): MAXIMUM POWER RATING, Watts: 300

PAGE NO.

4 of 29.

Subpart 2.1033 (continued)

(c) (8): VOLTAGES & CURRENTS IN ALL ELEMENTS IN FINAL R. F. STAGE,
INCLUDING FINAL TRANSISTOR OR SOLID STATE DEVICE:

COLLECTOR CURRENT, A = per manual
COLLECTOR VOLTAGE, Vdc = per manual
SUPPLY VOLTAGE, Vdc = 7.2

(c) (9): TUNE-UP PROCEDURE:

PLEASE SEE ATTACHED EXHIBITS

(c) (10): CIRCUIT DIAGRAM/CIRCUIT DESCRIPTION:
Including description of circuitry & devices provided for
determining and stabilizing frequency, for suppression of
spurious radiation, for limiting modulation and limiting
power.

PLEASE SEE ATTACHED EXHIBITS

(c) (11): LABEL INFORMATION:

PLEASE SEE ATTACHED EXHIBITS

(c) (12): PHOTOGRAPHS:

PLEASE SEE ATTACHED EXHIBITS

(c) (13): DIGITAL MODULATION DESCRIPTION:

ATTACHED EXHIBITS
x N/A

(c) (14): TEST AND MEASUREMENT DATA:

FOLLOWS

PAGE NO.

5 of 29.

Sub-part
2.1033(c) (14):TEST AND MEASUREMENT DATA

All tests and measurement data shown were performed in accordance with FCC Rules and Regulations, Volume II; Part 2, Sub-part J, Sections 2.947, 2.1033(c), 2.1041, 2.1046, 2.1047, 2.1079, 2.1051, 2.1053, 2.1055, 2.1057 and the following individual Parts:

- _____ 21 - Domestic Public Fixed Radio Services
- _____ 22 - Public Mobile Services
- _____ 22 Subpart H - Cellular Radiotelephone Service
- _____ 22.901(d) - Alternative technologies and auxiliary services
- _____ 23 - International Fixed Public Radiocommunication services
- _____ 24 - Personal Communications Services
- _____ 74 Subpart H - Low Power Auxiliary Stations
- _____ 80 - Stations in the Maritime Services
- _____ 80 Subpart E - General Technical Standards
- _____ 80 Subpart F - Equipment Authorization for Compulsory Ships
- _____ 80 Subpart K - Private Coast Stations and Marine Utility Stations
- _____ 80 Subpart S - Compulsory Radiotelephone Installations for Small Passenger Boats
- _____ 80 Subpart T - Radiotelephone Installation Required for Vessels on the Great Lakes
- _____ 80 Subpart U - Radiotelephone Installations Required by the Bridge-to-Bridge Act
- _____ 80 Subpart V - Emergency Position Indicating Radiobeacons (EPIRB'S)
- _____ 80 Subpart W - Global Maritime Distress and Safety System (GMDSS)
- _____ 80 Subpart X - Voluntary Radio Installations
- _____ 87 - Aviation Services
- x 90 - Private Land Mobile Radio Services
- _____ 94 - Private Operational-Fixed Microwave Service
- _____ 95 Subpart A - General Mobile Radio Service (GMRS)
- _____ 95 Subpart C - Radio Control (R/C) Radio Service
- _____ 95 Subpart D - Citizens Band (CB) Radio Service
- _____ 95 Subpart E - Family Radio Service
- _____ 95 Subpart F - Interactive Video and Data Service (IVDS)
- _____ 101 - Fixed Microwave Services

PAGE NO.

6 of 29.

STANDARD TEST CONDITIONS
and
ENGINEERING PRACTICES

Except as noted herein, the following conditions and procedures were observed during the testing:

In accordance with ANSI C63.4-1992, section 6.1.9, and unless otherwise indicated in the specific measurement results, the ambient temperature of the actual EUT was maintained within the range of 10° to 40°C (50° to 104 °F) unless the particular equipment requirements specify testing over a different temperature range. Also, unless otherwise indicated, the humidity levels were in the range of 10% to 90% relative humidity.

Prior to testing, the EUT was tuned up in accordance with the manufacturer's alignment procedures. All external gain controls were maintained at the position of maximum and/or optimum gain throughout the testing.

Measurement results, unless otherwise noted, are worst case measurements.

PAGE NO. 7 of 29.
NAME OF TEST: Carrier Output Power (Conducted)
SPECIFICATION: 47 CFR 2.1046(a)
GUIDE: ANSI/TIA/EIA-603-1992, Paragraph 2.2.1
TEST EQUIPMENT: As per attached page

MEASUREMENT PROCEDURE

1. The EUT was connected to a resistive coaxial attenuator of normal load impedance, and the unmodulated output power was measured by means of an R. F. Power Meter.
2. Measurement accuracy is $\pm 3\%$.

MEASUREMENT RESULTS
(Worst case)

FREQUENCY OF CARRIER, MHz = 823.937

<u>POWER SETTING</u>	<u>R. F. POWER, WATTS</u>
Low	1
High	2.5

Morton Flom, P. Eng.

SUPERVISED BY:

TRANSMITTER POWER CONDUCTED MEASUREMENTS

TEST 1: R. F. POWER OUTPUT
 TEST 2: FREQUENCY STABILITY

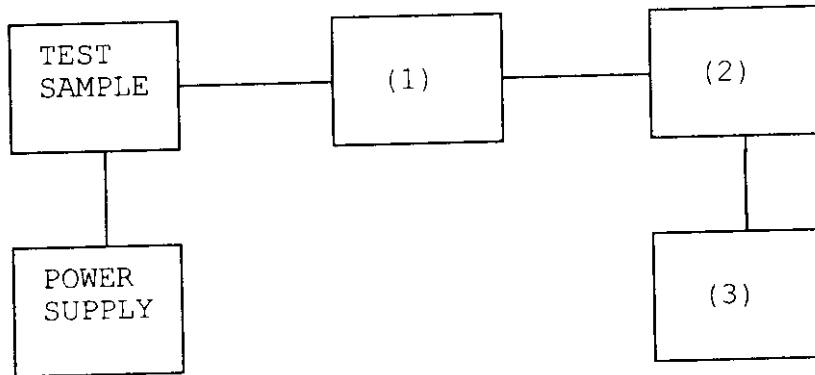

Asset	Description	s/n
(1)	<u>COAXIAL ATTENUATOR</u>	
—	i00122 Narda 766-10	7802
—	i00123 Narda 766-10	7802A
—	i00069 Bird 8329 (30 dB)	1006
<u>x</u>	i00113 Sierra 661A-3D	1059
(2)	<u>POWER METERS</u>	
—	i00014 HP 435A	1733A05836
<u>x</u>	i00039 HP 436A	2709A26776
<u>x</u>	i00020 HP 8901A POWER MODE	2105A01087
(3)	<u>FREQUENCY COUNTER</u>	
—	i00042 HP 5383A	1628A00959
<u>x</u>	i00019 HP 5334B	2704A00347
<u>x</u>	i00020 HP 8901A FREQUENCY MODE	2105A01087

PAGE NO. 9 of 29.
NAME OF TEST: Unwanted Emissions (Transmitter Conducted)
SPECIFICATION: 47 CFR 2.1051
GUIDE: ANSI/TIA/EIA-603-1992, Paragraph 2.2.13
TEST EQUIPMENT: As per attached page

MEASUREMENT PROCEDURE

1. The emissions were measured for the worst case as follows:
 - (a): within a band of frequencies defined by the carrier frequency plus and minus one channel.
 - (b): from the lowest frequency generated in the EUT and to at least the 10th harmonic of the carrier frequency, or 40 GHz, whichever is lower.
2. The magnitude of spurious emissions that are attenuated more than 20 dB below the permissible value need not be specified.
3. MEASUREMENT RESULTS: ATTACHED FOR WORST CASE

FREQUENCY OF CARRIER, MHz	=	823.937
SPECTRUM SEARCHED, GHz	=	0 to 10 x F _c
MAXIMUM RESPONSE, Hz	=	3160
ALL OTHER EMISSIONS	=	≥ 20 dB BELOW LIMIT
LIMIT(S), dBc		
	- (43+10xLOG P)	= -43 (1 Watt)
	- (43+10xLOG P)	= -47 (2.5 Watts)

Morton Flom P. Eng.

Morton Flom, P. Eng.

SUPERVISED BY:

TRANSMITTER SPURIOUS EMISSION

TEST A. OCCUPIED BANDWIDTH (IN-BAND SPURIOUS)
 TEST B. OUT-OF-BAND SPURIOUS

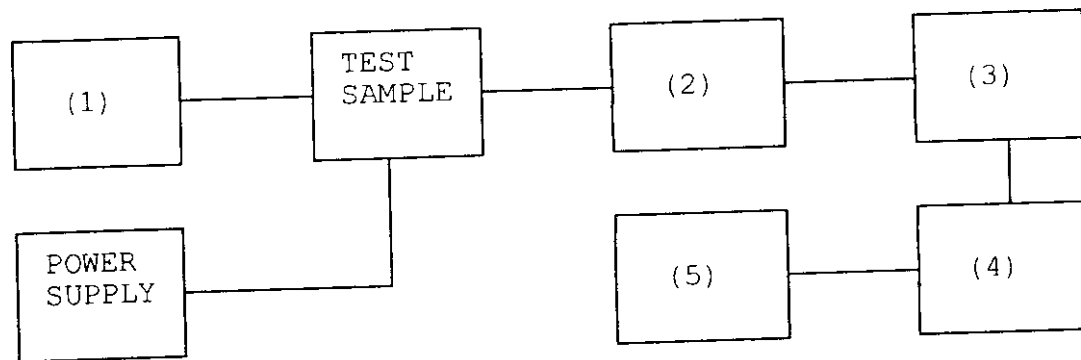

Asset	Description	s/n
(1)	<u>AUDIO OSCILLATOR/GENERATOR</u>	
—	i00010 HP 204D	1105A04683
—	i00017 HP 8903A	2216A01753
x	i00012 HP 3312A	1432A11250
(2)	<u>COAXIAL ATTENUATOR</u>	
—	i00122 Narda 766-10	7802
—	i00123 Narda 766-10	7802A
x	i00069 Bird 8329 (30 dB)	1006
x	i00113 Sierra 661A-3D	1059
(3)	<u>FILTERS; NOTCH, HP, LP, BP</u>	
x	i00126 Eagle TNF-1	100-250
x	i00125 Eagle TNF-1	50-60
x	i00124 Eagle TNF-1	250-850
(4)	<u>SPECTRUM ANALYZER</u>	
x	i00048 HP 8566B	2511A01467
—	i00029 HP 8563E	3213A00104
(5)	<u>SCOPE</u>	
—	i00058 HP 1741A	2251A09356
—	i00030 HP 54502A	2927A00209
—	i00071 Tektronix 935	1935-B011343

PAGE NO.

11 of 29.

NAME OF TEST: Unwanted Emissions (Transmitter Conducted)
 g98a0164: 1998-Oct-21 Wed 16:26:00
 STATE: 1:Low Power

FREQUENCY TUNED, MHz	FREQUENCY EMISSION, MHz	LEVEL, dBm	LEVEL, dBc	MARGIN, dB
823.937000	1647.895000	-40.4	-69.9	-27.4
823.937000	2471.706000	-42.8	-72.3	-29.8
823.937000	3295.490000	-44.5	-74	-31.5
823.937000	4120.064000	-44.9	-74.4	-31.9
823.937000	4943.783000	-45	-74.5	-32
823.937000	5767.898000	-45.1	-74.6	-32.1
823.937000	6591.769000	-36.8	-66.3	-23.8
823.937000	7415.197000	-38.9	-68.4	-25.9
823.937000	8239.571000	-38.8	-68.3	-25.8
823.937000	9063.154000	-38.1	-67.6	-25.1
823.937000	9887.284600	-38	-67.5	-25
823.937000	10711.385500	-38.2	-67.7	-25.2
823.937000	11535.160400	-36.3	-65.8	-23.3
823.937000	12359.248800	-37.8	-67.3	-24.8

PAGE NO.

12 of 29.

NAME OF TEST: Unwanted Emissions (Transmitter Conducted)
 g98a0156: 1998-Oct-21 Wed 15:28:00
 STATE: 2:High Power

FREQUENCY TUNED, MHz	FREQUENCY EMISSION, MHz	LEVEL, dBm	LEVEL, dBc	MARGIN, dB
823.937000	1647.878000	-32.7	-66.7	-19.7
823.937000	2471.900000	-42	-76	-29
823.937000	3295.402000	-45.2	-79.2	-32.2
823.937000	4120.138000	-44.6	-78.6	-31.6
823.937000	4943.759000	-43.9	-77.9	-30.9
823.937000	5767.945000	-45.4	-79.4	-32.4
823.937000	6591.630000	-38	-72	-25
823.937000	7414.976000	-39.2	-73.2	-26.2
823.937000	8239.128000	-38.8	-72.8	-25.8
823.937000	9063.622000	-38.7	-72.7	-25.7
823.937000	9887.690500	-37.3	-71.3	-24.3
823.937000	10711.393400	-38.4	-72.4	-25.4
823.937000	11534.910000	-37.9	-71.9	-24.9
823.937000	12359.293100	-38.3	-72.3	-25.3

PAGE NO. 13 of 29.
NAME OF TEST: Field Strength of Spurious Radiation
SPECIFICATION: 47 CFR 2.1053(a)
GUIDE: ANSI/TIA/EIA-603-1992, Paragraph 2.2.12
TEST EQUIPMENT: As per attached page

MEASUREMENT PROCEDURE

1. A description of the measurement facilities was filed with the FCC and was found to be in compliance with the requirements of Section 15.38, by letter from the FCC dated March 3, 1997, FILE 31040/SIT. All pertinent changes will be reported to the Commission by up-date prior to March 2000.
2. At first, in order to locate all spurious frequencies and approximate amplitudes, and to determine proper equipment functioning, the test sample was set up at a distance of three meters from the test instrument. Valid spurious signals were determined by switching the power on and off.
3. In the field, the test sample was placed on a wooden turntable above ground at three (or thirty) meters away from the search antenna. Excess power leads were coiled near the power supply.

The cables were oriented in order to obtain the maximum response. At each emission frequency, the turntable was rotated and the search antennas were raised and lowered vertically.
4. The emission was observed with both a vertically polarized and a horizontally polarized search antenna and the worst case was used.
6. The field strength of each emission within 20 dB of the limit was recorded and corrected with the appropriate cable and transducer factors.
7. The worst case for all channels is shown.
8. Measurement results: ATTACHED FOR WORST CASE

RADIATED TEST SETUP

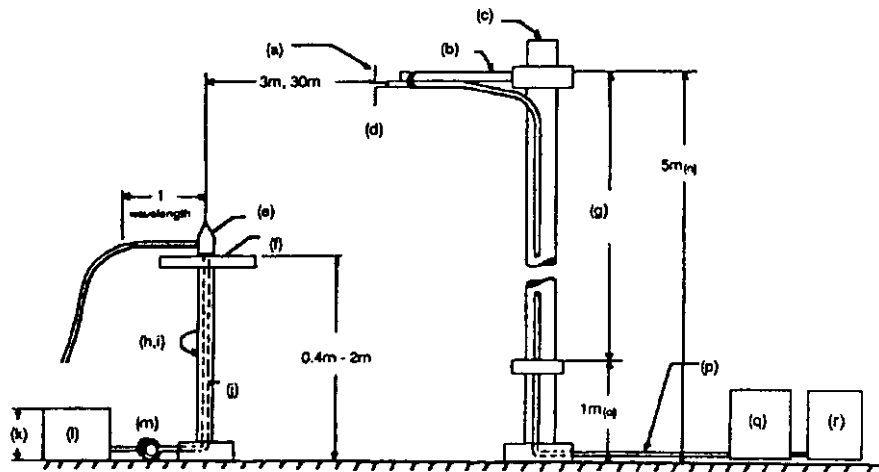

NOTES:

- (a) Search Antenna - Rotatable on boom
- (b) Non-metallic boom
- (c) Non-metallic mast
- (d) Adjustable horizontally
- (e) Equipment Under Test
- (f) Turntable
- (g) Boom adjustable in height.
- (h) External control cables routed horizontally at least one wavelength.
- (i) Rotatable
- (j) Cables routed through hollow turntable center
- (k) 30 cm or less
- (l) External power source
- (m) 10 cm diameter coil of excess cable
- (n) 25 cm (V), 1 m-7 m (V, H)
- (o) 25 cm from bottom end of 'V', 1m normally
- (p) Calibrated Cable at least 10m in length
- (q) Amplifier (optional)
- (r) Spectrum Analyzer

Asset	Description	s/n	Cycle	Last Cal
-------	-------------	-----	-------	----------

Per ANSI C63.4-1992, 10.1.4

TRANSDUCER

___	i00065	EMCO 3109B 100Hz-50MHz	2336	12 mo.	
___	i00033	Singer 94593-1 10kHz-32MHz	0219	12 mo.	
x	i00088	EMCO 3109-B 25MHz-300MHz	2336	12 mo.	Oct-98
x	i00089	Apral 2001 200MHz-1GHz	001500	12 mo.	Oct-98
x	i00103	EMCO 3115 1GHz-18GHz	9208-3925	12 mo.	Oct-98
___	i00085	EMCO 3116 10GHz-40GHz	2076	12 mo.	

AMPLIFIER

___	i00028	HP 8449A	2749A00121	12 mo.	Mar-98
-----	--------	----------	------------	--------	--------

SPECTRUM ANALYZER

___	i00029	HP 8563E	3213A00104	12 mo.	
x	i00033	HP 85462A	3625A00357	12 mo.	Dec-97
___	i00048	HP 8566B	2511AD1467	6 mo.	Mar-98

PAGE NO. 15 of 29.

NAME OF TEST: Field Strength of Spurious Radiation

ALL OTHER EMISSIONS = ≥ 20 dB BELOW LIMIT

EMISSION, MHz/HARMONIC	SPURIOUS LEVEL, dBc	
	Low	High
2nd to 10th	<-65	<-65

SUPERVISED BY:

Morton Flom, P. Eng.

PAGE NO. 16 of 29.
NAME OF TEST: Emission Masks (Occupied Bandwidth)
SPECIFICATION: 47 CFR 2.1049(c)(1)
GUIDE: ANSI/TIA/EIA-603-1992, Paragraph 2.2.11
TEST EQUIPMENT: As per previous page

MEASUREMENT PROCEDURE

1. The EUT and test equipment were set up as shown on the following page, with the Spectrum Analyzer connected.
2. For EUTs supporting audio modulation, the audio signal generator was adjusted to the frequency of maximum response and with output level set for ± 2.5 kHz deviation (or 50% modulation). With level constant, the signal level was increased 16 dB.
3. For EUTs supporting digital modulation, the digital modulation mode was operated to its maximum extent.
4. The Occupied Bandwidth was measured with the Spectrum Analyzer controls set as shown on the test results.
5. MEASUREMENT RESULTS: ATTACHED

PAGE NO.

17 of 29.

NAME OF TEST: Emission Masks (Occupied Bandwidth)
g98a0162: 1998-Oct-21 Wed 16:14:00
STATE: 1:Low Power

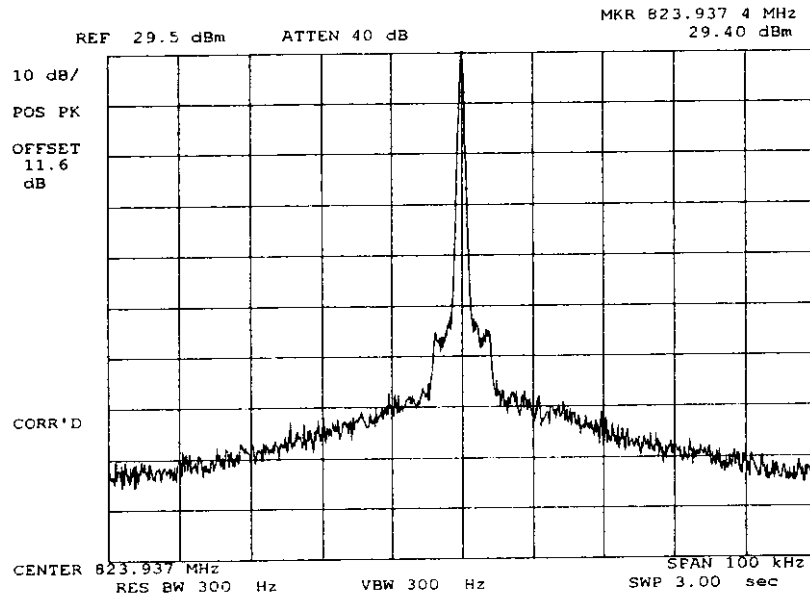

POWER:
MODULATION:

LOW
NONE

SUPERVISED BY:

Morton Flom P. Eng.
Morton Flom, P. Eng.

PAGE NO.

18 of 29.

NAME OF TEST: Emission Masks (Occupied Bandwidth)
g98a0163: 1998-Oct-21 Wed 16:16:00
STATE: 1:Low Power

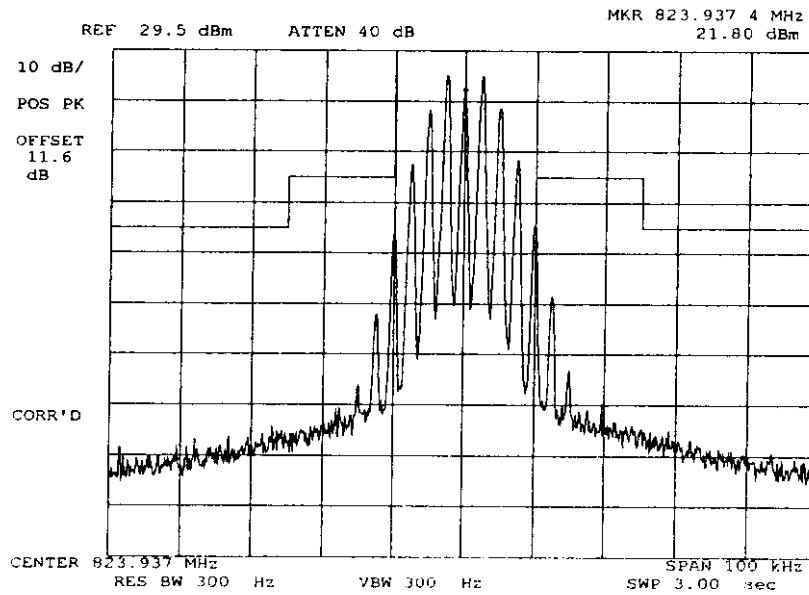

POWER:
MODULATION:

LOW
VOICE: 2500 Hz SINE WAVE
MASK: B, VHF/UHF 25kHz,
w/LPF

SUPERVISED BY:

Morton Flom, P. Eng.
Morton Flom, P. Eng.

PAGE NO.

19 of 29.

NAME OF TEST: Emission Masks (Occupied Bandwidth)
g98a0153: 1998-Oct-21 Wed 15:15:00
STATE: 2:High Power

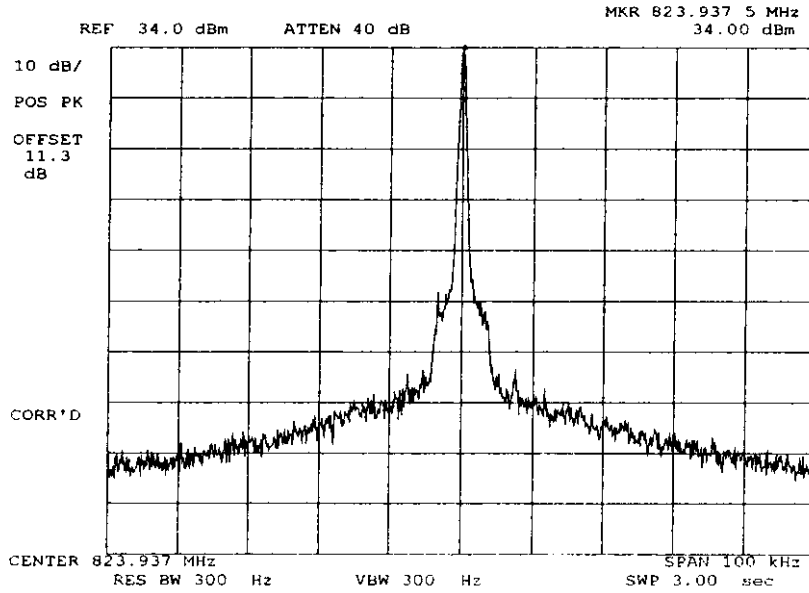

POWER: HIGH
MODULATION: NONE

SUPERVISED BY:

Morton Flom P. Eng.
Morton Flom, P. Eng.

PAGE NO.

20 of 29.

NAME OF TEST: Emission Masks (Occupied Bandwidth)
g98a0161: 1998-Oct-21 Wed 16:00:00
STATE: 2:High Power

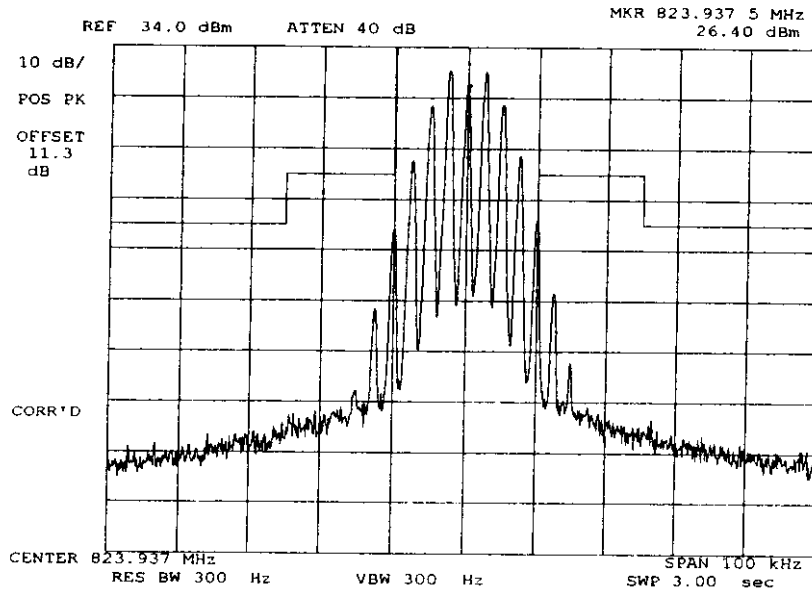

POWER:
MODULATION:

HIGH
VOICE: 2500 Hz SINE WAVE
MASK: B, VHF/UHF 25kHz,
w/LPF

SUPERVISED BY:

Morton Flom, P. Eng.

PAGE NO. 21 of 29.
NAME OF TEST: Audio Low Pass Filter (Voice Input)
SPECIFICATION: 47 CFR 2.1047(a)
GUIDE: ANSI/TIA/EIA-603-1992, Paragraph 2.2.15
TEST EQUIPMENT: As per attached page

MEASUREMENT PROCEDURE

1. The EUT and test equipment were set up such that the audio input was connected at the input to the modulation limiter, and the modulated stage.
2. The audio output was connected at the output to the modulated stage.
3. MEASUREMENT RESULTS: ATTACHED

TRANSMITTER TEST SET-UP

- TEST A. MODULATION CAPABILITY/DISTORTION
- TEST B. AUDIO FREQUENCY RESPONSE
- TEST C. HUM AND NOISE LEVEL
- TEST D. RESPONSE OF LOW PASS FILTER
- TEST E. MODULATION LIMITING

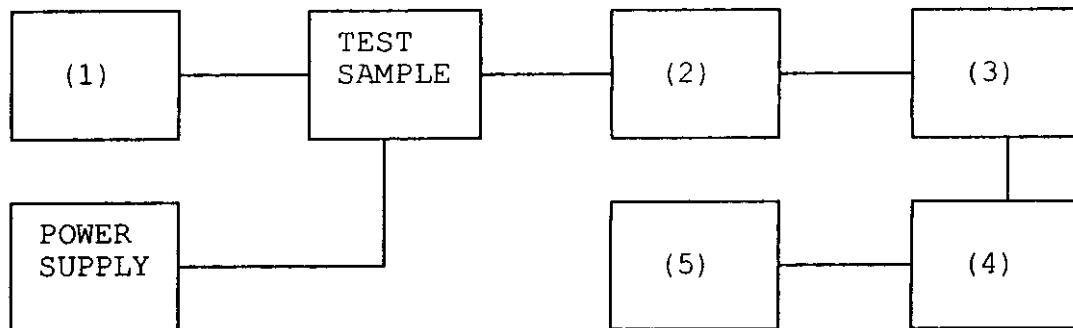

Asset Description s/n

(1)	<u>LINE IMPEDANCE STABILIZATION NETWORK</u>	
	i00010 HP 204D	1105A04683
<u>x</u>	i00017 HP 8903A	2216A01753
<u>x</u>	i00118 HP 33120A	US36002064
(2)	<u>COAXIAL ATTENUATOR</u>	
	i00122 NARDA 766-10	7802
	i00123 NARDA 766-10	7802A
<u>x</u>	i00113 SIERRA 661A-3D	1059
	i00069 BIRD 8329 (30 dB)	10066
(3)	<u>MODULATION ANALYZER</u>	
<u>x</u>	i00020 HP 8901A	2105A01087
(4)	<u>AUDIO ANALYZER</u>	
<u>x</u>	i00017 HP 8903A	2216A01753
(5)	<u>SCOPE</u>	
	i00058 HP 1741A	2215A09356
	i00071 Tektronix 935	1935-B011343

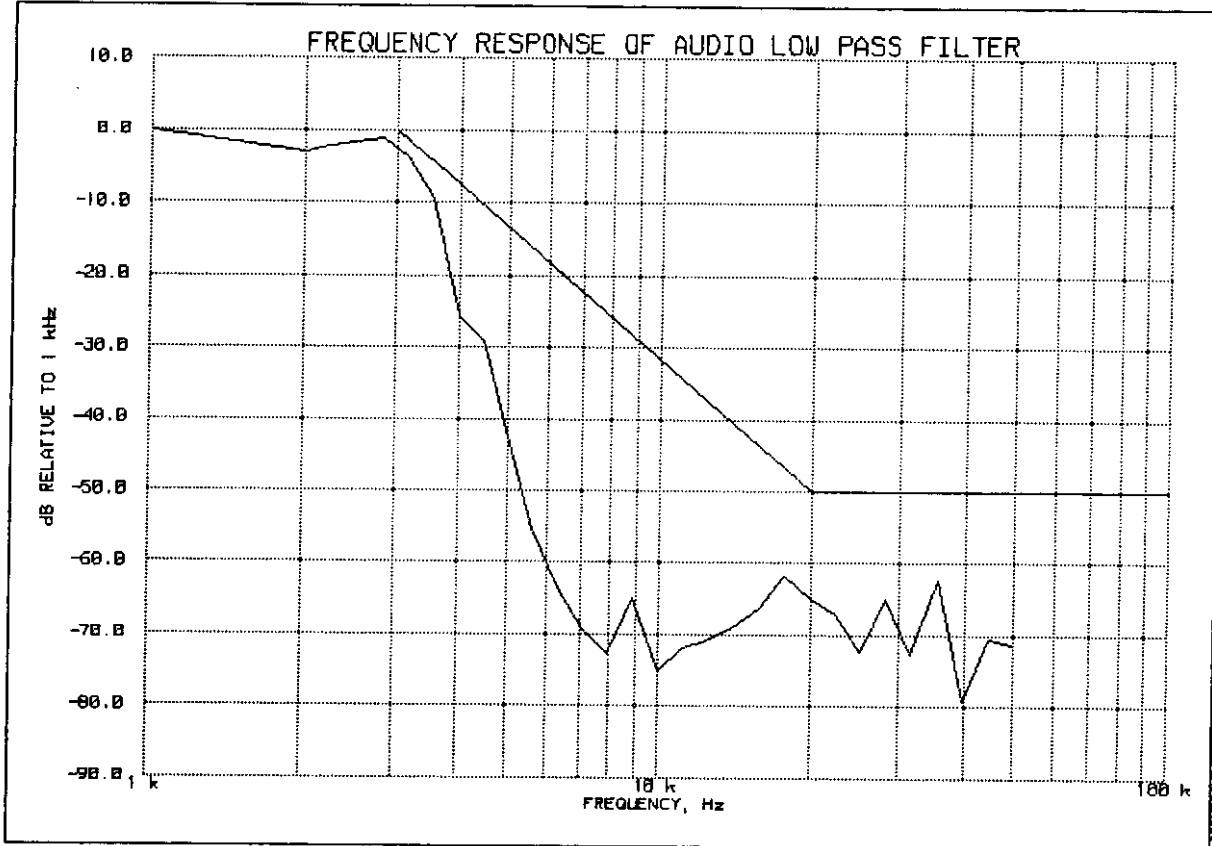

PEAK AUDIO FREQUENCY, Hz: 2820

PAGE NO. 24 of 29.
NAME OF TEST: Audio Frequency Response
SPECIFICATION: 47 CFR 2.1047(a)
GUIDE: ANSI/TIA/EIA-603-1992, Paragraph 2.2.6
TEST EQUIPMENT: As per previous page

MEASUREMENT PROCEDURE

1. The EUT and test equipment were set up as shown on the following page.
2. The audio signal generator was connected to the audio input circuit/microphone of the EUT.
3. The audio signal input was adjusted to obtain 20% modulation at 1 kHz, and this point was taken as the 0 dB reference level.
4. With input levels held constant and below limiting at all frequencies, the audio signal generator was varied from 100 Hz to 50 kHz.
5. The response in dB relative to 1 kHz was then measured, using the HP 8901A Modulation Analyzer.
6. MEASUREMENT RESULTS: ATTACHED

TRANSMITTER AUDIO FREQUENCY RESPONSE

KENWOOD, TK-480

21 OCT 1998, 12:26

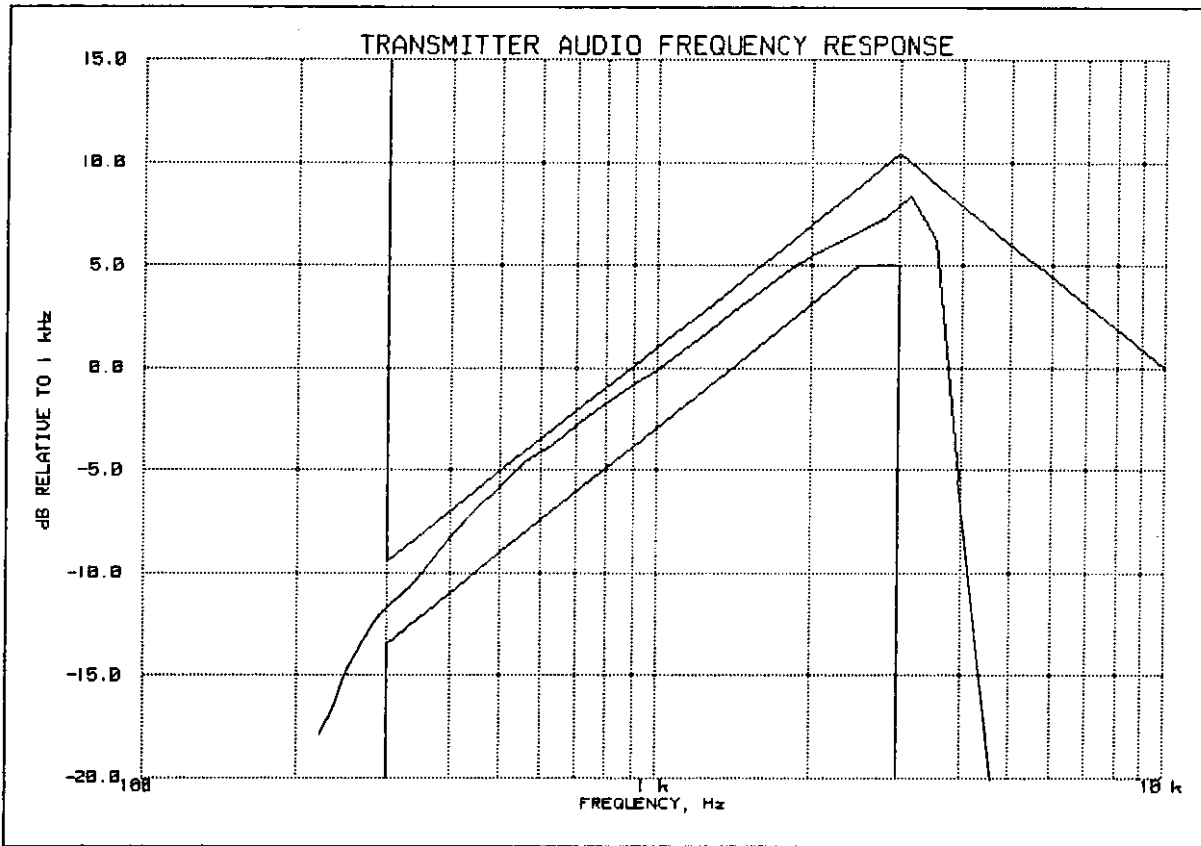

COPYRIGHT © 1988 BY H. FLOP ASSOCIATES, INC. ALL RIGHTS RESERVED.

PEAK AUDIO FREQUENCY, Hz: 3160

TABLE VALUES:

FREQUENCY, Hz	LEVEL, dB	FREQUENCY, Hz	LEVEL, dB	FREQUENCY, Hz	LEVEL, dB
300	-12.0	30000	-17.9		
20000	-17.7	50000	-17.7		

PAGE NO. 26 of 29.
NAME OF TEST: Modulation Limiting
SPECIFICATION: 47 CFR 2.1047(b)
GUIDE: ANSI/TIA/EIA-603-1992, Paragraph 2.2.3
TEST EQUIPMENT: As per previous page

MEASUREMENT PROCEDURE

1. The signal generator was connected to the input of the EUT as for "Frequency Response of the Modulating Circuit."
2. The modulation response was measured for each of three frequencies (one of which was the frequency of maximum response), and the input voltage was varied and was observed on an HP 8901A Modulation Analyzer.
3. The input level was varied from 30% modulation (± 1.5 kHz deviation) to at least 20 dB higher than the saturation point.
4. Measurements were performed for both negative and positive modulation and the respective results were recorded.
5. MEASUREMENT RESULTS: ATTACHED

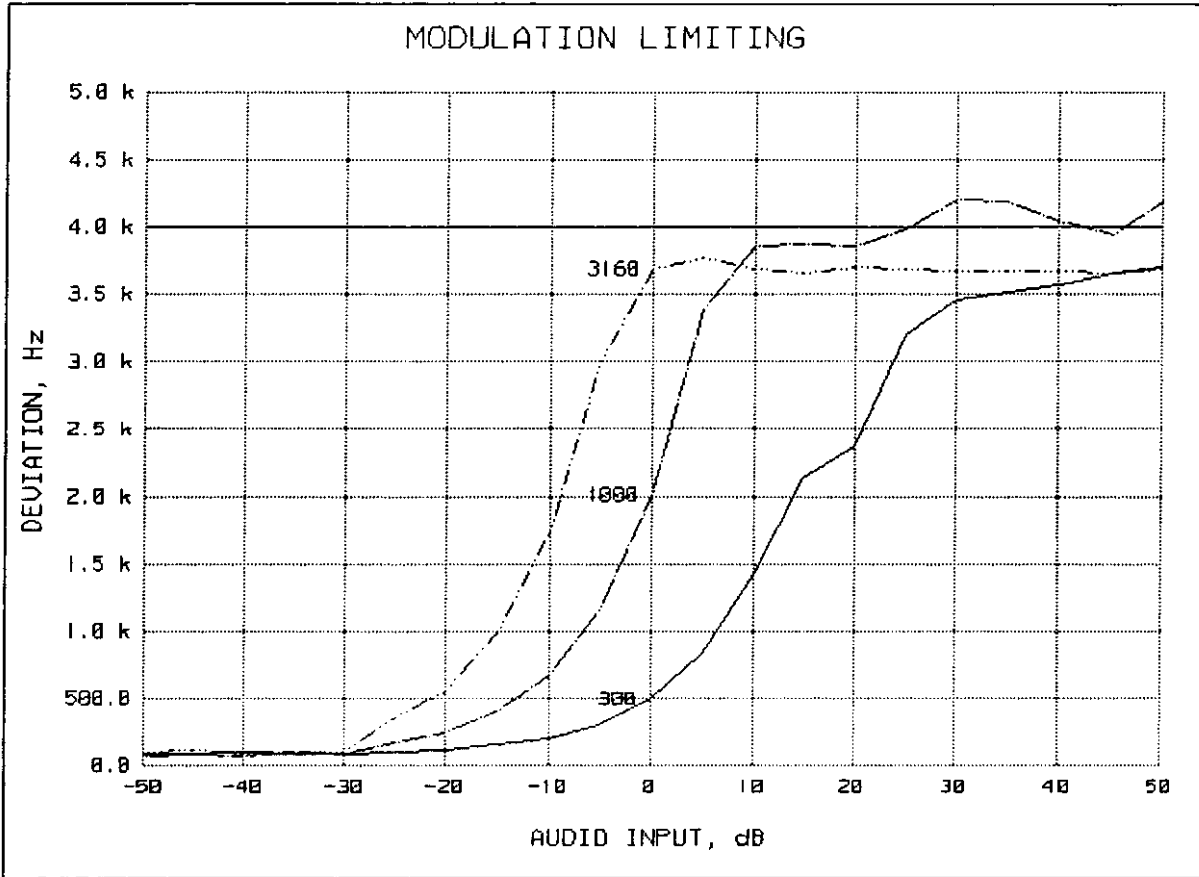

COPYRIGHT © 1998 BY W. P. FOUR ASSOCIATES, INC. ALL RIGHTS RESERVED.

REFERENCE DEVIATION, kHz = 2
REFERENCE MODULATION, Hz = 1000
PEAKS = POSITIVE
AUDIO AMPLITUDE, mV = 16.75

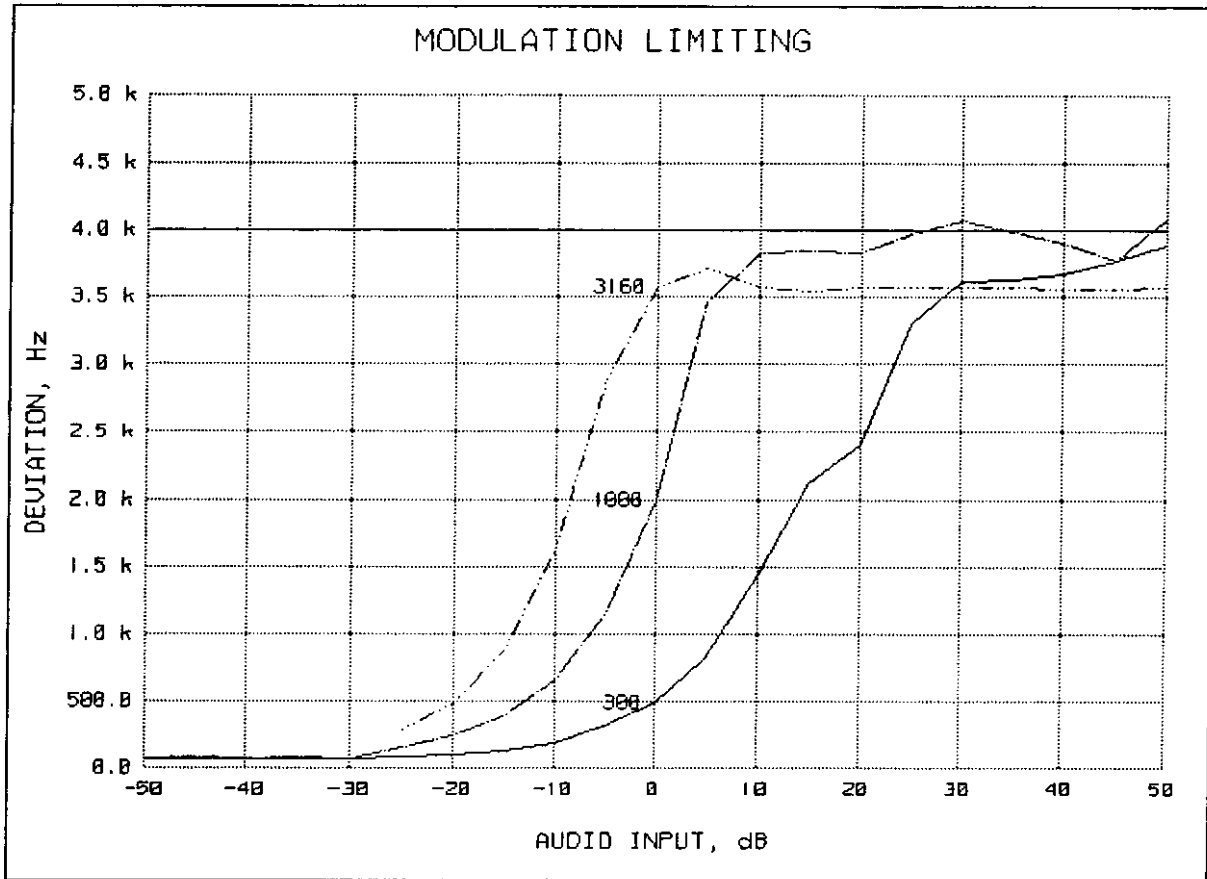

REFERENCE DEVIATION, kHz = 2
REFERENCE MODULATION, Hz = 1000
PEAKS = NEGATIVE
AUDIO AMPLITUDE, mV = 16.75

PAGE NO. 29 of 29.
NAME OF TEST: Necessary Bandwidth and Emission Bandwidth
SPECIFICATION: 47 CFR 2.202 (g)

MODULATION = 14K0F3E

NECESSARY BANDWIDTH CALCULATION:

MAXIMUM MODULATION (M), kHz = 3
MAXIMUM DEVIATION (D), kHz = 4
CONSTANT FACTOR (K) = 1
NECESSARY BANDWIDTH (B_N), kHz = (2 x M) + (2 x D x K)
= 14.0

SUPERVISED BY:



Morton Flom, P. Eng.