



**Flom Test Labs**  
EMI, EMC, RF Testing Experts Since 1963

toll-free: (866) 311-3268  
fax: (480) 926-3598  
<http://www.flomlabs.com>  
[info@flomlabs.com](mailto:info@flomlabs.com)

Date: September 7, 2006

Federal Communications Commission  
Via: Electronic Filing

Attention: Authorization & Evaluation Division

Applicant: Kenwood USA Corporation  
Equipment: TK 690H-3  
FCC ID: ALH22923130  
FCC Rules: 22 and 90

Gentlemen:

On behalf of the Applicant, enclosed please find Application Form 731, Engineering Test Report and all pertinent documentation, the whole for approval of the referenced equipment as shown.

Filing fees are attached.

We trust the same is in order. Should you need any further information, kindly contact the writer who is authorized to act as agent.

Sincerely yours,

Hoosamuddin S. Bandukwala, Senior  
Engineer

Flom Test Labs  
3356 N. San Marcos Place, Suite 107  
Chandler, Arizona 85225-7176  
(866) 311-3268 phone, (480) 926-3598 fax

FCC ID: ALH22923130  
MFA p0670012, d0690004

Date: September 7, 2006

Federal Communications Commission  
Via: Electronic Filing

Attention: Authorization & Evaluation Division

Applicant: Kenwood USA Corporation  
Equipment: TK 690H-3  
FCC ID: ALH22923130  
FCC Rules: 22 and 90, Class II Permissive Change

Gentlemen:

On behalf of the Applicant, enclosed please find Application Form 731, Engineering Test Report and all pertinent documentation, the whole for approval of the referenced equipment as shown i.e.:

- a) Application Form
- b) Test Report (if applicable)
- c) Filing Fees
- d) Copy of Original Grant
- e) Expository Statement and/or letter by Applicant
- f) Photos (if applicable)
- g) Label Drawing (if changes have been made)

We trust the same is in order. Should you need any further information, kindly contact the writer who is authorized to act as agent.

Sincerely yours,

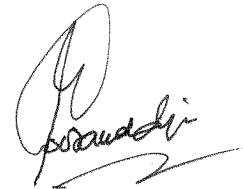

Hoosamuddin S. Bandukwala, Senior  
Engineer



**Flom Test Labs**  
EMI, EMC, RF Testing Experts Since 1963

toll-free: (866) 311-3268  
fax: (480) 926-3598  
<http://www.flomlabs.com>  
[info@flomlabs.com](mailto:info@flomlabs.com)

## Transmitter Certification

of

FCC ID: ALH22923130  
Model: TK 690H-3

to

**Federal Communications Commission**

Rule Part(s) 22 and 90

Date of report: September 7, 2006

**On the Behalf of the Applicant:**

Kenwood USA Corporation

**At the Request of:**

P.O.

Kenwood USA Corporation  
Communications Division  
3975 Johns Creek Court, Suite 300  
Suwanee, GA 30024

**Attention of:**

Joel E. Berger, Research & Development  
[JBerger@kenwoodusa.com](mailto:JBerger@kenwoodusa.com)  
(678) 474-4722; FAX: -4731

**Supervised by:**

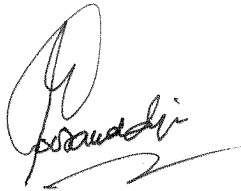
  
Hoosamuddin S. Bandukwala, Senior  
Engineer

Flom Test Labs  
3356 N. San Marcos Place, Suite 107  
Chandler, Arizona 85225-7176  
(866) 311-3268 phone, (480) 926-3598 fax

FCC ID: ALH22923130  
MFA p0670012, d0690004



**Flom Test Labs**  
EMI, EMC, RF Testing Experts Since 1963

toll-free: (866) 311-3268  
fax: (480) 926-3598  
<http://www.flomlabs.com>  
[info@flomlabs.com](mailto:info@flomlabs.com)

## Transmitter Certification

of

FCC ID: ALH22923130

Model: TK 690H-3

to

### Federal Communications Commission

Rule Part(s) 22 and 90  
Class I Permissive Change

Date of report: September 7, 2006

#### On the Behalf of the Applicant:

Kenwood USA Corporation

#### At the Request of:

P.O.

Kenwood USA Corporation  
Communications Division  
3975 Johns Creek Court, Suite 300  
Suwanee, GA 30024

#### Attention of:

Joel E. Berger, Research & Development  
[JBerger@kenwoodusa.com](mailto:JBerger@kenwoodusa.com)  
(678) 474-4722; FAX: -4731

#### Supervised by:

Hoosamuddin S. Bandukwala, Senior  
Engineer

Flom Test Labs  
3356 N. San Marcos Place, Suite 107  
Chandler, Arizona 85225-7176  
(866) 311-3268 phone, (480) 926-3598 fax

FCC ID: ALH22923130  
MFA p0670012, d0690004

## List of Exhibits

(FCC **Certification** (Transmitters) - Revised 9/28/98)

Applicant: Kenwood USA Corporation

FCC ID: ALH22923130

### By Applicant:

1. Letter of Authorization
2. Confidentiality Request: 0.457 And 0.459
3. Part 90.203(e) & (g) Attestation
4. Identification Drawings, 2.1033(c)(11)
  - Label
  - Location of Label
  - Compliance Statement
  - Location of Compliance Statement
5. Photographs, 2.1033(c)(12)
6. Documentation: 2.1033(c)
  - (3) User Manual
  - (9) Tune Up Info
  - (10) Schematic Diagram
  - (10) Circuit Description
  - Block Diagram
  - Parts List
  - Active Devices
7. MPE/SAR Report

### By M.F.A. Inc.:

- A. Testimonial & Statement of Certification

## The Applicant has been cautioned as to the following:

### 15.21 Information to the User.

The users manual or instruction manual for an intentional radiator shall caution the user that changes or modifications not expressly approved by the party responsible for compliance could void the user's authority to operate the equipment.

### 15.27(a) Special Accessories.

Equipment marketed to a consumer must be capable of complying with the necessary regulations in the configuration in which the equipment is marketed. Where special accessories, such as shielded cables and/or special connectors are required to enable an unintentional or intentional radiator to comply with the emission limits in this part, the equipment must be marketed with, i.e. shipped and sold with, those special accessories. However, in lieu of shipping or packaging the special accessories with the unintentional or intentional radiator, the responsible party may employ other methods of ensuring that the special accessories are provided to the consumer, without additional charge.

Information detailing any alternative method used to supply the special accessories for a grant of equipment authorization or retained in the verification records, as appropriate. The party responsible for the equipment, as detailed in § 2.909 of this chapter, shall ensure that these special accessories are provided with the equipment. The instruction manual for such devices shall include appropriate instructions on the first page of text concerned with the installation of the device that these special accessories must be used with the device. It is the responsibility of the user to use the needed special accessories supplied with the equipment.

Table of Contents

<u>Rule</u>	<u>Description</u>	<u>Page</u>
2.1033(c)(14)	Rule Summary	2
	Standard Test Conditions and Engineering Practices	3
	Expository Statement for Permissive Changes	4
2.1033(c)	General Information Required	5
2.1046(a)	Carrier Output Power (Conducted)	7
2.1046(a)	ERP Carrier Power (Radiated)	9
2.1046(a)	RF Power Output (Radiated)	9
2.1051	Unwanted Emissions (Transmitter Conducted)	10
2.1053(a)	Field Strength of Spurious Radiation	12
2.1049(c)(1)	Emission Masks (Occupied Bandwidth)	15
90.214	Transient Frequency Behavior	15
2.202(g)	Necessary Bandwidth and Emission Bandwidth	15

Required information per ISO/IEC Guide 25-1990, paragraph 13.2:

- a) **Test Report**
- b) Laboratory: M. Flom Associates, Inc.  
 (FCC: 31040/SIT) 3356 N. San Marcos Place, Suite 107  
 (Canada: IC 2044) Chandler, AZ 85225
- c) Report Number: d0690004
- d) Client: Kenwood USA Corporation  
 Communications Division  
 3975 Johns Creek Court, Suite 300  
 Suwanee, GA 30024
- e) Identification: TK 690H-3  
 FCC ID: ALH22923130
- EUT Description: VHF FM Tranciever
- f) EUT Condition: Not required unless specified in individual tests.
- g) Report Date: September 7, 2006  
 EUT Received:
- h, j, k): As indicated in individual tests.
- i) Sampling method: No sampling procedure used.
- l) Uncertainty: In accordance with MFA internal quality manual.
- m) Supervised by:
- n) Results: The results presented in this report relate only to the item tested.
- o) Reproduction: This report must not be reproduced, except in full, without written permission from this laboratory.

Accessories used during testing:

Type	Quantity	Manufacturer	Model	Serial No.	FCC ID
------	----------	--------------	-------	------------	--------



Sub-part

2.1033(c)(14):

## Test and Measurement Data

All tests and measurement data shown were performed in accordance with FCC Rules and Regulations, Volume II; Part 2, Sub-part J, Sections 2.947, 2.1033(c), 2.1041, 2.1046, 2.1047, 2.1079, 2.1051, 2.1053, 2.1055, 2.1057 and the following individual Parts:

- 21 - Domestic Public Fixed Radio Services
- 22 - Public Mobile Services
- 22 Subpart H - Cellular Radiotelephone Service
- 22.901(d) - Alternative technologies and auxiliary services
- 23 - International Fixed Public Radiocommunication services
- 24 - Personal Communications Services
- 74 Subpart H - Low Power Auxiliary Stations
- 80 - Stations in the Maritime Services
- 80 Subpart E - General Technical Standards
- 80 Subpart F - Equipment Authorization for Compulsory Ships
- 80 Subpart K - Private Coast Stations and Marine Utility Stations
- 80 Subpart S - Compulsory Radiotelephone Installations for Small Passenger Boats
- 80 Subpart T - Radiotelephone Installation Required for Vessels on the Great Lakes
- 80 Subpart U - Radiotelephone Installations Required by the Bridge-to-Bridge Act
- 80 Subpart V - Emergency Position Indicating Radio Beacons (EPIRB'S)
- 80 Subpart W - Global Maritime Distress and Safety System (GMDSS)
- 80 Subpart X - Voluntary Radio Installations
- 87 - Aviation Services
- 90 - Private Land Mobile Radio Services
- 94 - Private Operational-Fixed Microwave Service
- 95 Subpart A - General Mobile Radio Service (GMRS)
- 95 Subpart C - Radio Control (R/C) Radio Service
- 95 Subpart D - Citizens Band (CB) Radio Service
- 95 Subpart E - Family Radio Service
- 95 Subpart F - Interactive Video and Data Service (IVDS)
- 97 - Amateur Radio Service
- 101 - Fixed Microwave Services

## Standard Test Conditions and Engineering Practices

Except as noted herein, the following conditions and procedures were observed during the testing:

In accordance with ANSI C63.4-2003 Draft, section 6.1.9, and unless otherwise indicated in the specific measurement results, the ambient temperature of the actual EUT was maintained within the range of 10° to 40°C (50° to 104 °F) unless the particular equipment requirements specify testing over a different temperature range. Also, unless otherwise indicated, the humidity levels were in the range of 10% to 90% relative humidity.

Prior to testing, the EUT was tuned up in accordance with the manufacturer's alignment procedures. All external gain controls were maintained at the position of maximum and/or optimum gain throughout the testing.

Measurement results, unless otherwise noted, are worst-case measurements.

 <p>The image shows a certificate from A2LA (The American Association for Laboratory Accreditation) accrediting M. Flom Associates, Inc. in Chandler, AZ for technical competence in the field of Electrical Testing. The certificate includes the A2LA logo, the text 'ACCREDITED LABORATORY', and a signature of the Accreditation Council President. It also mentions the certificate number 2152-01 and the validity date of August 31, 2009.</p>	<h3 style="margin-top: 0;">A2LA</h3> <hr/> <p>“A2LA has accredited M. Flom Associates, Inc. Chandler, AZ for technical competence in the field of Electrical Testing. The accreditation covers the specific tests and types of tests listed on the agreed scope of accreditation. This laboratory meets the requirements of ISO/IEC 17025 - 1999 ‘General Requirements for the Competence of Testing and Calibration Laboratories’ and any additional program requirements in the identified field of testing.”</p> <hr/> <p>Certificate Number: <b>2152-01</b></p>
---	---

## Expository Statement

Permissive Change

Applicant: Kenwood USA Corporation

FCC ID: ALH22923130

The applicant has made design changes/improvements to the originally FCC approved equipment.

Data contained herein confirms that a Permissive Change to the unit has been effected and that the performance of the unit is at or better than the levels originally reported to the commission.

The following changes/improvements have been made as per attached letter of Explanation:

The customer has expanded the frequency range.

## List of General Information Required for Certification

In Accordance with FCC Rules and Regulations,  
Volume II, Part 2 and to

22 and 90

Sub-part 2.1033

(c)(1): **Name and Address of Applicant:**

Kenwood USA Corporation  
Communications Division  
3975 Johns Creek Court, Suite 300  
Suwanee, GA 30024

**Manufacturer:**

Kenwood Corporation  
14-6, Dogenzaka 1-Chome  
Shibuya-ku, Tokyo 150, Japan

(c)(2): **FCC ID:** ALH22923130

**Model Number:** TK 690H-3

(c)(3): **Instruction Manual(s):**

Please see attached exhibits

(c)(4): **Type of Emission:** 16K0F3E

(c)(5): **Frequency Range, MHz:** 39.05 to 49.95

(c)(6): **Power Rating, Watts:** 45 to 110  
 Switchable       Variable       N/A

**FCC Grant Note:**

(c)(7): **Maximum Power Rating, Watts:** 300

**DUT Results:** Passes  Fails

Subpart 2.1033 (continued)

(c)(8): Voltages & currents in all elements in final RF stage, including final transistor or solid-state device:

Collector Current, A	=	per manual
Collector Voltage, Vdc	=	per manual
Supply Voltage, Vdc	=	13.8

(c)(9): **Tune-Up Procedure:**

Please see attached exhibits

(c)(10): **Circuit Diagram/Circuit Description:**

Including description of circuitry & devices provided for determining and stabilizing frequency, for suppression of spurious radiation, for limiting modulation and limiting power.

Please see attached exhibits

(c)(11): **Label Information:**

Please see attached exhibits

(c)(12): **Photographs:**

Please see attached exhibits

(c)(13): **Digital Modulation Description:**

     Attached Exhibits

  x   N/A

(c)(14): **Test and Measurement Data:**

Follows

**Name of Test:** Carrier Output Power (Conducted)  
**Specification:** 47 CFR 2.1046(a)  
**Guide:** ANSI/TIA/EIA-603-1992, Paragraph 2.2.1

**Measurement Procedure**

- A) The EUT was connected to a resistive coaxial attenuator of normal load impedance, and the unmodulated output power was measured by means of an RF Power Meter.  
 B) Measurement accuracy is  $\pm 3\%$ .

**Transmitter Test Set-Up: RF Power Output**

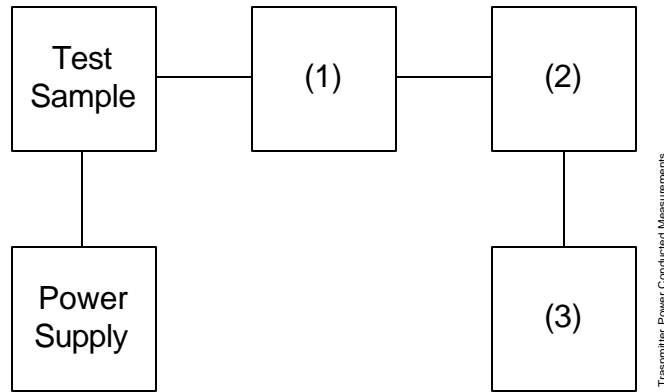

Asset	Description	s/n	Cycle	Last Cal
(1)	<b>Coaxial Attenuator</b>			
X	i00231/2 PASTERNAK PE7021-30 (30 dB)	231 or 232	NCR	
	i00122/3 NARDA 766 (10 dB)	7802 or 7802A	NCR	
(2)	<b>Spectrum Analyzer</b>			
X	i00048 HP 8566B Spectrum Analyzer	2511A01467	12 mo.	Jun-06
(3)	<b>Frequency Counter</b>			
X	i00020 HP 8901A Frequency Mode	2105A01087	12 mo.	May-06

**Name of Test:** Carrier Output Power (Conducted)

**Measurement Results**  
 (Worst case)

Frequency of Carrier, MHz = 39.05  
 Ambient Temperature = 23°C ± 3°C

Power Setting	RF Power, Watts
Low	45
High	110

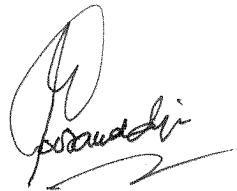

Performed by:

Hoosamuddin S. Bandukwala, Senior Engineer

**Name of Test:** Unwanted Emissions (Transmitter Conducted)

**Specification:** 47 CFR 2.1051

**Guide:** ANSI/TIA/EIA-603-1992, Paragraph 2.2.13

**Measurement Procedure**

- A) The emissions were measured for the worst case as follows:
  - 1). within a band of frequencies defined by the carrier frequency plus and minus one channel.
  - 2). from the lowest frequency generated in the EUT and to at least the 10th harmonic of the carrier frequency, or 40 GHz, whichever is lower.
- B) The magnitude of spurious emissions that are attenuated more than 20 dB below the permissible value need not be specified.

**Transmitter Test Set-Up: Spurious Emission**

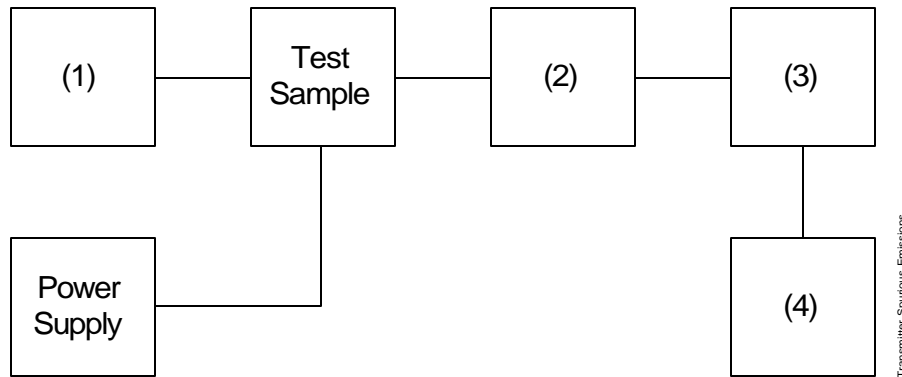

Asset	Description	s/n		
<b>(2) Coaxial Attenuator</b>				
X	i00231/2	PASTERNAK PE7021-30 (30 dB)	231 or 232	NCR
	i0012/3	NARDA 766 (10 dB)	7802 or 7802A	NCR
<b>(3) Filters; Notch, HP, LP, BP</b>				
	None required			
<b>(4) Spectrum Analyzer</b>				
X	i00048	HP 8566B Spectrum Analyzer	2511A01467	12 mo. Oct-04
	i00029	HP 8563E Spectrum Analyzer	3213A00104	12 mo. May-04



Name of Test: Unwanted Emissions (Transmitter Conducted)

**Measurement Results**  
(Worst Case)

Summary:

Frequency of carrier, MHz = 39.05  
 Spectrum Searched, GHz = 0 to 10 x F<sub>c</sub>  
 Maximum Response, Hz =  
 All Other Emissions = = 20 dB Below Limit  
 Limit(s), dBc  
 -(43+10xLOG P) = -63.4 (110 Watts)

Tabulated Results follow:

**Measurement Results**

g0690005: 2006-Sep-06 Wed 18:12:00  
 State: 2:High Power

Ambient Temperature: 23°C ± 3°C

Frequency Tuned, MHz	Frequency Emission, MHz	Level, dBm	Level, dBc	Margin, dB
39.050000	78.109000	-13.6	-63.6	-0.6
39.050000	117.156000	-20.5	-70.5	-7.5
39.050000	156.611000	-33	-83	-20
39.050000	195.251000	-31.8	-81.8	-18.8
39.050000	234.285000	-32.3	-82.3	-19.3
39.050000	273.352000	-32.2	-82.2	-19.2
39.050000	312.293000	-33	-83	-20
39.050000	351.611000	-33.3	-83.3	-20.3
39.050000	390.016000	-33.8	-83.8	-20.8

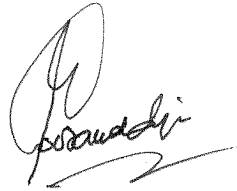

Performed by:

Hoosamuddin S. Bandukwala, Senior Engineer

**Name of Test:** Field Strength of Spurious Radiation  
**Specification:** 47 CFR 2.1053(a)  
**Guide:** ANSI/TIA/EIA-603-1992/2001, Paragraph 1.2.12 and Table 16, 47 CFR 22.917

### Measurement Procedure

**Definition:**

Radiated spurious emissions are emissions from the equipment when transmitting into a non-radiating load on a frequency or frequencies which are outside an occupied band sufficient to ensure transmission of information of required quality for the class of communications desired.

**Method of Measurement:**

- A) Connect the equipment as illustrated
- B) Adjust the spectrum analyzer for the following settings:
  - 1) Resolution Bandwidth 100 kHz (<1 GHz), 1 MHz (> 1GHz).
  - 2) Video Bandwidth = 3 times Resolution Bandwidth, or 30 kHz (22.917)
  - 3) Sweep Speed  $\leq 2000$  Hz/second
  - 4) Detector Mode = Mean or Average Power
- C) Place the transmitter to be tested on the turntable in the standard test site. The transmitter is transmitting into a non-radiating load that is placed on the turntable. The RF cable to this load should be of minimum length.

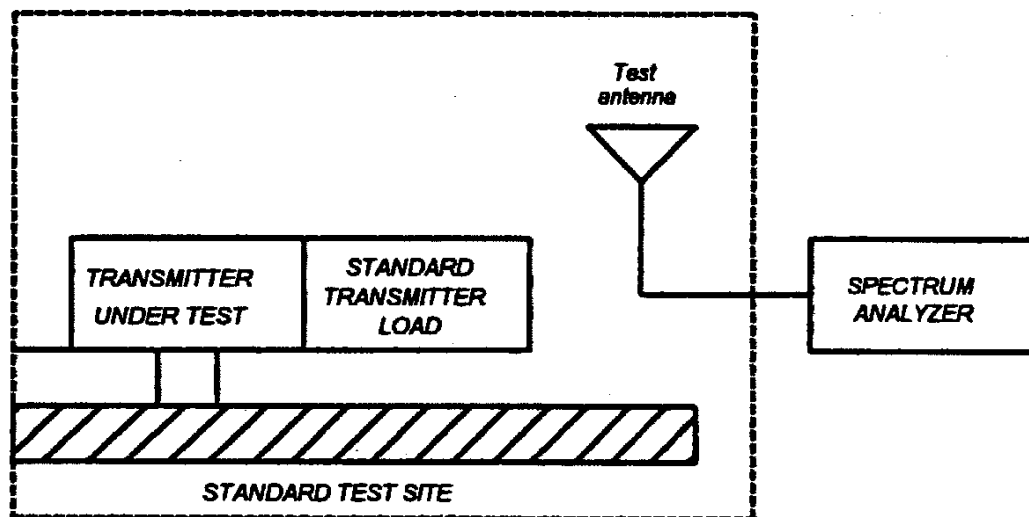

**Name of Test:** Field Strength of Spurious Radiation (Cont.)

- D) For each spurious measurement the test antenna should be adjusted to the correct length for the frequency involved. This length may be determined from a calibration ruler supplied with the equipment. Measurements shall be made from the lowest radio frequency generated in the equipment to the tenth harmonic of the carrier, except for the region close to the carrier equal to  $\pm$  the test bandwidth (see section 1.3.4.4).
- E) For each spurious frequency, raise and lower the test antenna from 1 m to 4 m to obtain a maximum reading on the spectrum analyzer with the test antenna at horizontal polarity. Repeat this procedure to obtain the highest possible reading. Record this maximum reading.
- F) Repeat step E) for each spurious frequency with the test antenna polarized vertically.

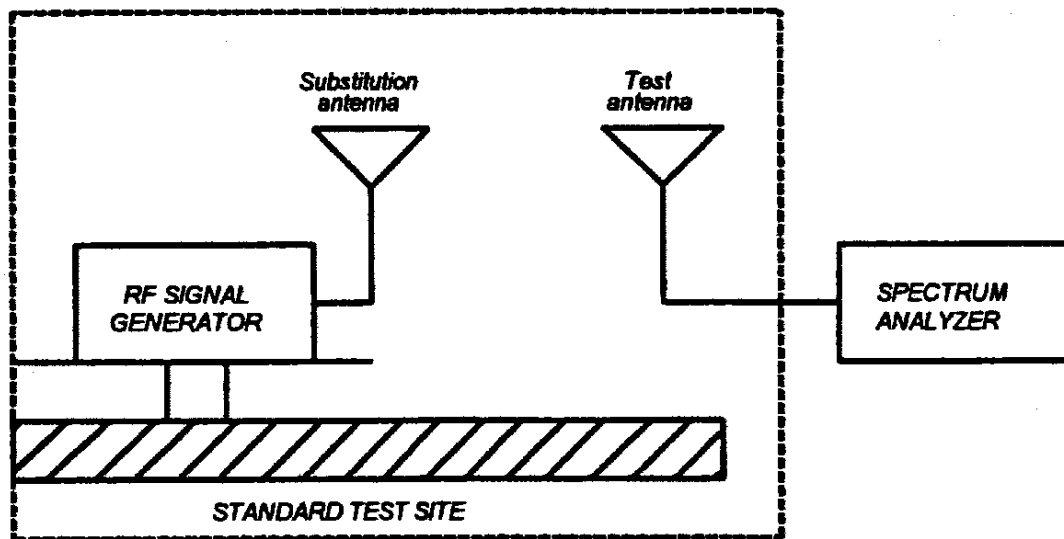

- G) Reconnect the equipment as illustrated.
- H) Keep the spectrum analyzer adjusted as in step B).
- I) Remove the transmitter and replace it with a substitution antenna (the antenna should be half-wavelength for each frequency involved). The center of the substitution antenna should be approximately at the same location as the center of the transmitter. At lower frequencies, where the substitution antenna is very long, this will be impossible to achieve when the antenna is polarized vertically. In such case the lower end of the antenna should be 0.3 m above the ground.

**Name of Test:** Field Strength of Spurious Radiation (Cont.)

- J) Feed the substitution antenna at the transmitter end with a signal generator connected to the antenna by means of a non-radiating cable. With the antennas at both ends horizontally polarized and with the signal generator tuned to a particular spurious frequency, raise and lower the test antenna to obtain a maximum reading at the spectrum analyzer. Adjust the level of the signal generator output until the previously recorded maximum reading for this set of conditions is obtained. This should be done carefully repeating the adjustment of the test antenna and generator output.
- K) Repeat step J) with both antennas vertically polarized for each spurious frequency.
- L) Calculate power in dBm into a reference ideal half-wave dipole antenna by reducing the readings obtained in steps J) and K) by the power loss in the cable between the generator and the antenna and further corrected for the gain of the substitution antenna used relative to an ideal half-wave dipole antenna.
- M) The levels recorded in step L) are absolute levels of radiated spurious emissions in dBm. The radiated spurious emissions in dB can be calculated by the following:

Radiated spurious emissions dB =

$$10\log_{10}(\text{TX power in watts}/0.001) - \text{the levels in step I)}$$

*NOTE: It is permissible that other antennas provided can be referenced to a dipole.*

### Test Equipment

Asset	Description	s/n	Cycle	Last Cal
<b>Transducer</b>				
i00088	EMCO 3109-B 25MHz-300MHz	2336	12 mo.	Sep-03
X i00089	Apr1 2001 200MHz-1GHz	001500	12 mo.	Jun-06
X i00103	EMCO 3115 1GHz-18GHz	9208-3925	12 mo.	Jun-06
<b>Amplifier</b>				
i00028	HP 8449A	2749A00121	12 mo.	
<b>Spectrum Analyzer</b>				
X i00029	HP 8563E	3213A00104	12 mo.	Jan-06
X i00033	HP 85462A	3625A00357	12 mo.	Oct-05
<b>Substitution Generator</b>				
X i00067	HP 8920A Communication TS	3345U01242	12 mo.	Jun-06
i00207	HP 8753D Network Analyzer	3410A08514	12 mo.	Jul-04

**Microphone, Antenna Port, and Cabling**

Microphone \_\_\_\_\_ Cable Length \_\_\_\_\_ Meters  
 Antenna Port Terminated \_\_\_\_\_ Load \_\_\_\_\_ Antenna Gain \_\_\_\_\_  
 All Ports Terminated by Load \_\_\_\_\_ Peripheral \_\_\_\_\_

**Testimonial  
and  
Statement of Certification**

**This is to Certify:**

1. **That** the application was prepared either by, or under the direct supervision of, the undersigned.
2. **That** the technical data supplied with the application was taken under my direction and supervision.
3. **That** the data was obtained on representative units, randomly selected.
4. **That**, to the best of my knowledge and belief, the facts set forth in the application and accompanying technical data are true and correct.

Certifying Engineer:

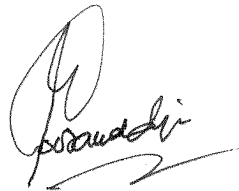

Hoosamuddin S. Bandukwala, Senior  
Engineer