



Test report No:
2210113R-RF-US-P06V01

FCC & ISED TEST REPORT

Product Name	Bluetooth headset
Trademark	Plantronics
Model and /or type reference	VFOCUS2
FCC ID	AL8-VFOCUS2A
IC	457A-VFOCUS2A
Applicant's name / address	Plantronics, Inc. 345 Encinal Street, Santa Cruz, CA95060 USA
Test method requested, standard	FCC CFR Title 47 Part 15 Subpart C Section 15.247 ANSI C63.10: 2013 KD558074 D01 15.247 Meas Guidance v05r02 RSS-Gen Issue 5 /RSS-247 Issue 2
Verdict Summary	IN COMPLIANCE
Tested by (name / position & signature)	Adma Lu/Project Engineer
Approved by (name / position & signature)	Jack Zhang/ Supervisor
Date of issue	2022-01-24
Report Version	V1.0
Report template No	Template_FCC 15.247-RF-V1.0

INDEX

	page
General conditions	5
Environmental conditions	5
Possible test case verdicts	6
Abbreviations.....	6
Document History.....	7
Remarks and Comments	7
Used Equipment.....	8
Uncertainty	10
1 General Information	11
1.1 General Description of the Item(s).....	11
1.2 Antenna Information	12
1.3 Channel List.....	13
2 Description of Test Setup.....	14
2.1 Operating mode(s) used for tests	14
2.2 Auxiliary equipment / Test software for the EUT	14
2.3 Test Configuration / Block diagram used for tests.....	15
2.4 Testing process	16
3 Verdict summary section.....	17
3.1 Standards	17
3.2 Deviation(s) from the Standard(s) / Test Specification(s).....	17
3.3 Overview of results	18
3.4 Test Facility.....	20
4 Test Results	21
4.1 Conducted Emission.....	21
4.1.1 Limit	21
4.1.2 Test Setup	21
4.1.3 Test Procedure	21
4.1.4 Test Data	22
4.2 Emissions in restricted frequency bands	24
4.2.1 Limit	24
4.2.2 Test Setup	26
4.2.3 Test Procedure	27
4.2.4 Test Data	28
4.3 20dB Bandwidth.....	48

4.3.1	Limit	48
4.3.2	Test Setup	48
4.3.3	Test Procedure	48
4.3.4	Test Data	49
4.4	CarrierFrequencySeparation	50
4.4.1	Limit	50
4.4.2	Test Setup	50
4.4.3	Test Procedure	50
4.4.4	Test Data	51
4.5	Number of hopping Frequencies	52
4.5.1	Limit	52
4.5.2	Test Setup	52
4.5.3	Test Procedure	52
4.5.4	Test Data	53
4.6	Time of Occupancy(Dwell Time)	54
4.6.1	Limit	54
4.6.2	Test Setup	54
4.6.3	Test Procedure	54
4.6.4	Test Data	55
4.7	Peak Output Power.....	58
4.7.1	Limit	58
4.7.2	Test Setup	58
4.7.3	Test Procedure	59
4.7.4	Test Data	60
4.8	Emissions in non-restricted frequency band	61
4.8.1	Limit	61
4.8.2	Test Setup	61
4.8.3	Test Procedure	61
4.8.4	Test Data	62
4.9	Duty cycle	66
4.9.1	Limit	66
4.9.2	Test Setup	66
4.9.3	Test Procedure	66
4.9.4	Test Data	67
4.10	Band Edge	68
4.10.1	Limit	68
4.10.2	Test Setup	68

4.10.3	Test Procedure	68
4.10.4	Test Data	69
4.11	Antenna Requirement.....	93
4.11.1	Limit:.....	93
4.11.2	Antenna Connector Construction:	93
5	Test setup photo and EUT Photo	94

COMPETENCES AND GUARANTEES

DEKRA is a testing laboratory competent to carry out the tests described in this report.

In order to assure the traceability to other national and international laboratories, DEKRA has a calibration and maintenance program for its measurement equipment.

DEKRA guarantees the reliability of the data presented in this report, which is the result of the measurements and the tests performed to the item under test on the date and under the conditions stated in the report and it is based on the knowledge and technical facilities available at DEKRA at the time of performance of the test.

DEKRA is liable to the client for the maintenance of the confidentiality of all information related to the item under test and the results of the test.

The results presented in this Test Report apply only to the particular item under test established in this document.

IMPORTANT: No parts of this report may be reproduced or quoted out of context, in any form or by any means, except in full, without the previous written permission of DEKRA.

GENERAL CONDITIONS

Test Location	No. 99, Hongye Road, Suzhou Industrial Park Suzhou, 215006, P.R. China
Date(receive sample)	Jan. 05, 2022
Date (start test)	Jan. 07, 2022
Date (finish test)	Jan. 20, 2022

1. This report is only referred to the item that has undergone the test.
2. This report does not constitute or imply on its own an approval of the product by the Certification Bodies or Competent Authorities.
3. This document is only valid if complete; no partial reproduction can be made without previous written permission of DEKRA.
4. This test report cannot be used partially or in full for publicity and/or promotional purposes without previous written permission of DEKRA.

ENVIRONMENTAL CONDITIONS

The climatic conditions during the tests are within the limits specified by the manufacturer for the operation of the EUT and the test equipment. The climatic conditions during the tests were within the following limits:

Ambient temperature	15 °C – 35 °C
Relative Humidity air	30% - 60%

If explicitly required in the basic standard or applied product / product family standard the climatic values are recorded and documented separately in this test report.

POSSIBLE TEST CASE VERDICTS

Test case does not apply to test object	N/A
Test object does meet requirement	P (Pass) / PASS
Test object does not meet requirement	F (Fail) / FAIL
Not measured	N/M

ABBREVIATIONS

For the purposes of the present document, the following abbreviations apply:

EUT	: Equipment Under Test
QP	: Quasi-Peak
CAV	: CISPR Average
AV	: Average
CDN	: Coupling Decoupling Network
SAC	: Semi-Anechoic Chamber
OATS	: Open Area Test Site
BW	: Bandwidth
AM	: Amplitude Modulation
PM	: Pulse Modulation
HCP	: Horizontal Coupling Plane
VCP	: Vertical Coupling Plane
U_N	: Nominal voltage
T_x	: Transmitter
R_x	: Receiver
N/A	: Not Applicable
N/M	: Not Measured

DOCUMENT HISTORY

Report No.	Version	Description	Issued Date
2210113R-RF-US-P06V01	V1.0	Initial issue of report.	2022-01-24

REMARKS AND COMMENTS

1. The equipment under test (EUT) does meet the essential requirements of the stated standard(s)/test(s).
2. These test results on a sample of the device are for the purpose of demonstrating Compliance with Part 15 Subpart C Paragraph 15.247, RSS-Gen Issue 5, RSS-247 Issue 2.
3. The measurement result is considered in conformance with the requirement if it is within the prescribed limit, It is not necessary to account the uncertainty associated with the measurement result.
4. The test results presented in this report relate only to the object tested.
5. The test report shall not be reproduced without the written approval of DEKRA Testing and Certification (Suzhou) Co., Ltd.
6. This report will not be used for social proof function in China market.
7. DEKRA declines any responsibility with the following test data provided by customer that may affect the validity of result:
 - Chapter 1.1 General Description of the Item(s);
 - Chapter 1.2 Antenna Information;
 - Chapter 1.3Channel List.

USED EQUIPMENT

AC Power Line Conducted Emission / TR1

Instrument	Manufacturer	Model No.	Serial No.	Cal. Date	Next Cal. Date
EMI Test Receiver	R&S	ESCI	100906	2021.04.28	2022.04.27
Two-Line V-Network	R&S	ENV216	101044	2021.03.20	2022.03.19
50ohm Termination	SHX	TF2	7081403	2021.09.04	2022.09.03
50ohm Coaxial Switch	Anritsu	MP59B	6200464462	N/A	N/A
Temperature/Humidity Meter	RTS	RTS-8S	TR1-TH	2021.07.09	2022.07.08
Dekra test software	Dekra	-	-	-	-

Emissions in non-restricted frequency bands/ Occupied Bandwidth/ Fundamental emission output power/ Power Spectral Density/Band Edge/ TR8

Instrument	Manufacturer	Model No.	Serial No.	Cal. Date	Next Cal. Date
Spectrum Analyzer	Agilent	N9010A	MY48030494	2021.07.11	2022.07.10
EXA Spectrum Analyzer	Keysight	N9010A	MY55370495	2021.03.20	2022.03.19
MXA Signal Analyzer	Keysight	N9020A	MY56060147	2021.07.11	2022.07.10
4TX MIMO Power Sensor	Keysight	X8750A	MY59400102	2021.02.11	2022.02.10
Temperature/Humidity Meter	RTS	RTS-8S	RF08	2021.07.09	2022.07.08

Radiated Emission(30MHz-1GHz) / AC3

Instrument	Manufacturer	Model No.	Serial No.	Cal. Date	Next Cal. Date
EMI Test Receiver	R&S	ESCI	100176	2021.08.15	2022.08.14
Loop Antenna	R&S	HFH2-Z2	833799/003	2021.03.04	2022.03.03
Bilog Antenna	Teseq GmbH	CBL6112D	27613	2021.08.23	2022.08.22
Coaxial Cable	Huber+Suhner	RG 214	AC3-C	2021.03.31	2022.03.30
Temperature/Humidity Meter	RTS	RTS-8S	AC3-TH	2021.11.23	2022.11.22
Dekra test software	Dekra	-	-	-	-

Radiated Emission(1GHz-40GHz) / AC5

Instrument	Manufacturer	Model No.	Serial No.	Cal. Date	Next Cal. Date
EXA Spectrum Analyzer	Keysight	N9010A	MY55370495	2021.03.20	2022.03.19
Preamplifier	EMCI	EMC184045SE	980263	2021.05.22	2022.05.21
DRG Horn Antenna	ETS-Lindgren	3117	00167055	2021.08.23	2022.08.22
Broad-Band Horn Antenna	Schwarzbeck	BBHA9170	294	2021.04.14	2023.04.13
Coaxial Cable	Huber+Suhner	SUCOFLEX 106	AC5-C2	2021.03.31	2022.03.30
Coaxial Cable	ROSENBERGER	LA1-C011- 2000/3000	AC5-40G	2021.03.20	2022.03.19
Temperature/Humidity Meter	RTS	RTS-8S	AC5-TH	2021.07.09	2022.07.08
Dekra test software	Dekra	-	-	-	-

UNCERTAINTY

Uncertainties have been calculated according to the DEKRA internal document. The reported expanded uncertainties are based on a standard uncertainty multiplied by a coverage factor of $k=2$, providing a level of confidence of approximately 95%. The Uncertainties is comply with standard required as below.

Test item	Uncertainty
Conducted Emission	± 2.02 dB
Emissions in restricted frequency bands	above 1G : ± 3.9 dB below 1G is : ± 3.8 dB
20dB Bandwidth	± 1 kHz
Carrier Frequency Separation	± 1 kHz
Number of Hopping Frequencies	± 1 kHz
Time of Occupancy (Dwell Time)	± 0.1 us
Peak Output Power	± 1.0 dB
Emissions in non-restricted frequency bands	± 1.0 dB
Radiated Emission Band Edge	above 1G : ± 3.9 dB below 1G : ± 3.8 dB

1 GENERAL INFORMATION

1.1 General Description of the Item(s)

Product Name	Bluetooth headset
Model No.	VFOCUS2
FCC ID.....	AL8-VFOCUS2A
IC	457A-VFOCUS2A
Manufacturer	Plantronics, Inc.
Manufacturer Address	345 Encinal Street, Santa Cruz, CA95060 USA

Wireless specification	Bluetooth					
Bluetooth Specification.....	V3.0					
Operating frequency range(s)	2400~2483.5MHz					
Type of Modulation	GFSK , Pi/4 DQPSK, 8DPSK					
PHYs	<input checked="" type="checkbox"/>	GFSK	<input checked="" type="checkbox"/>	Pi/4 DQPSK	<input checked="" type="checkbox"/>	8DPSK
Data Rate	<input checked="" type="checkbox"/>	1Mbit/s	<input checked="" type="checkbox"/>	2Mbit/s	<input checked="" type="checkbox"/>	3Mbit/s
Number of channel	79					

Rated power supply..... :	Voltage and Frequency					
	<input type="checkbox"/>	AC: 220 – 240 V, 50/60 Hz				
	<input type="checkbox"/>	AC: 100 – 240 V, 50/60 Hz				
	<input checked="" type="checkbox"/>	DC: 3.3~4.2 V				
	<input type="checkbox"/>	Adapter: Input: 100-240V,50/60H, 0.3A Output:5V,2A ,10W				
Mounting position	<input type="checkbox"/>	Table top equipment				
	<input type="checkbox"/>	Wall/Ceiling mounted equipment				
	<input type="checkbox"/>	Floor standing equipment				
	<input checked="" type="checkbox"/>	Head-mounted equipment				
	<input type="checkbox"/>	Other: Watch				

1.2 Antenna Information

Antenna model / type number	N/A		
Antenna serial number	N/A		
Antenna Delivery	<input checked="" type="checkbox"/>	1TX + 1RX	
	<input type="checkbox"/>	2TX + 2RX	
	<input type="checkbox"/>	Others:.....	
Antenna technology.....	<input checked="" type="checkbox"/>	SISO	
	<input type="checkbox"/>	MIMO	<input type="checkbox"/> CDD
			<input type="checkbox"/> Beam-forming
Antenna Type	<input type="checkbox"/>	External	<input type="checkbox"/> Dipole
			<input type="checkbox"/> Sectorized
	<input checked="" type="checkbox"/>	Internal	<input type="checkbox"/> PIFA
			<input checked="" type="checkbox"/> PCB
			<input type="checkbox"/> Dipole
			<input type="checkbox"/> Others.....
Antenna Gain.....	3.59 dBi		

1.3 Channel List

Bluetooth Working Frequency of Each Channel: (For V3.0)							
Channel	Frequency	Channel	Frequency	Channel	Frequency	Channel	Frequency
00	2402 MHz	01	2403 MHz	02	2404 MHz	03	2405 MHz
04	2406 MHz	05	2407 MHz	06	2408 MHz	07	2409 MHz
08	2410 MHz	09	2411 MHz	10	2412 MHz	11	2413 MHz
12	2414 MHz	13	2415 MHz	14	2416 MHz	15	2417 MHz
16	2418 MHz	17	2419 MHz	18	2420 MHz	19	2421 MHz
20	2422 MHz	21	2423 MHz	22	2424 MHz	23	2425 MHz
24	2426 MHz	25	2427 MHz	26	2428 MHz	27	2429 MHz
28	2430 MHz	29	2431 MHz	30	2432 MHz	31	2433 MHz
32	2434 MHz	33	2435 MHz	34	2436 MHz	35	2437 MHz
36	2438 MHz	37	2439 MHz	38	2440 MHz	39	2441 MHz
40	2442 MHz	41	2443 MHz	42	2444 MHz	43	2445 MHz
44	2446 MHz	45	2447 MHz	46	2448 MHz	47	2449 MHz
48	2450 MHz	49	2451 MHz	50	2452 MHz	51	2453 MHz
52	2454 MHz	53	2455 MHz	54	2456 MHz	55	2457 MHz
56	2458 MHz	57	2459 MHz	58	2460 MHz	59	2461 MHz
60	2462 MHz	61	2463 MHz	62	2464 MHz	63	2465 MHz
64	2466 MHz	65	2467 MHz	66	2468 MHz	67	2469 MHz
68	2470 MHz	69	2471 MHz	70	2472 MHz	71	2473 MHz
72	2474 MHz	73	2475 MHz	74	2476 MHz	75	2477 MHz
76	2478 MHz	77	2479 MHz	78	2480 MHz	N/A	N/A

Note: The general description of the Item(s), antenna information and channel list in clause 1 are provided and confirmed by the client.

2 DESCRIPTION OF TEST SETUP

2.1 Operating mode(s) used for tests

During the tests the following operating mode(s) has(have) been used.

Test Mode For Bluetooth	Mode 1: Transmitter-1Mbps(GFSK_DH5)
	Mode 2: Transmitter-2Mbps(Pi/4 DQPSK_2DH5)
	Mode 3: Transmitter-3Mbps(8DPSK_3DH5)
	Mode 4: Transmitter-Hopping-1Mbps(GFSK_DH5)
	Mode 5: Transmitter-Hopping-2Mbps(Pi/4 DQPSK_2DH5)
	Mode 6: Transmitter-Hopping-3Mbps(8DPSK_3DH5)

2.2 Auxiliary equipment / Test software for the EUT

Auxiliary equipment	Type / Version	Manufacturer	Supplied by
Notebook	2526	Think Pad	N/A
Software	Type / Version	Manufacturer	Supplied by
BlueTest3	N/A	N/A	N/A

2.3 Test Configuration / Block diagram used for tests

Test setup Diagram- AC Line Conducted Emission Test

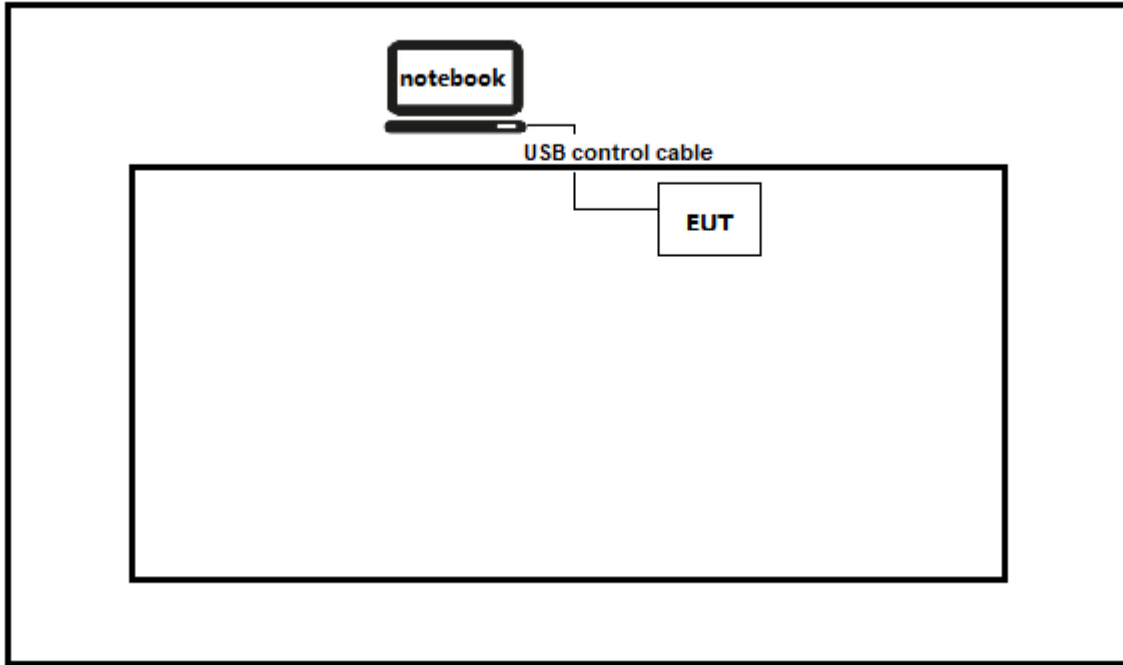

Test setup Diagram- Radiated Emission

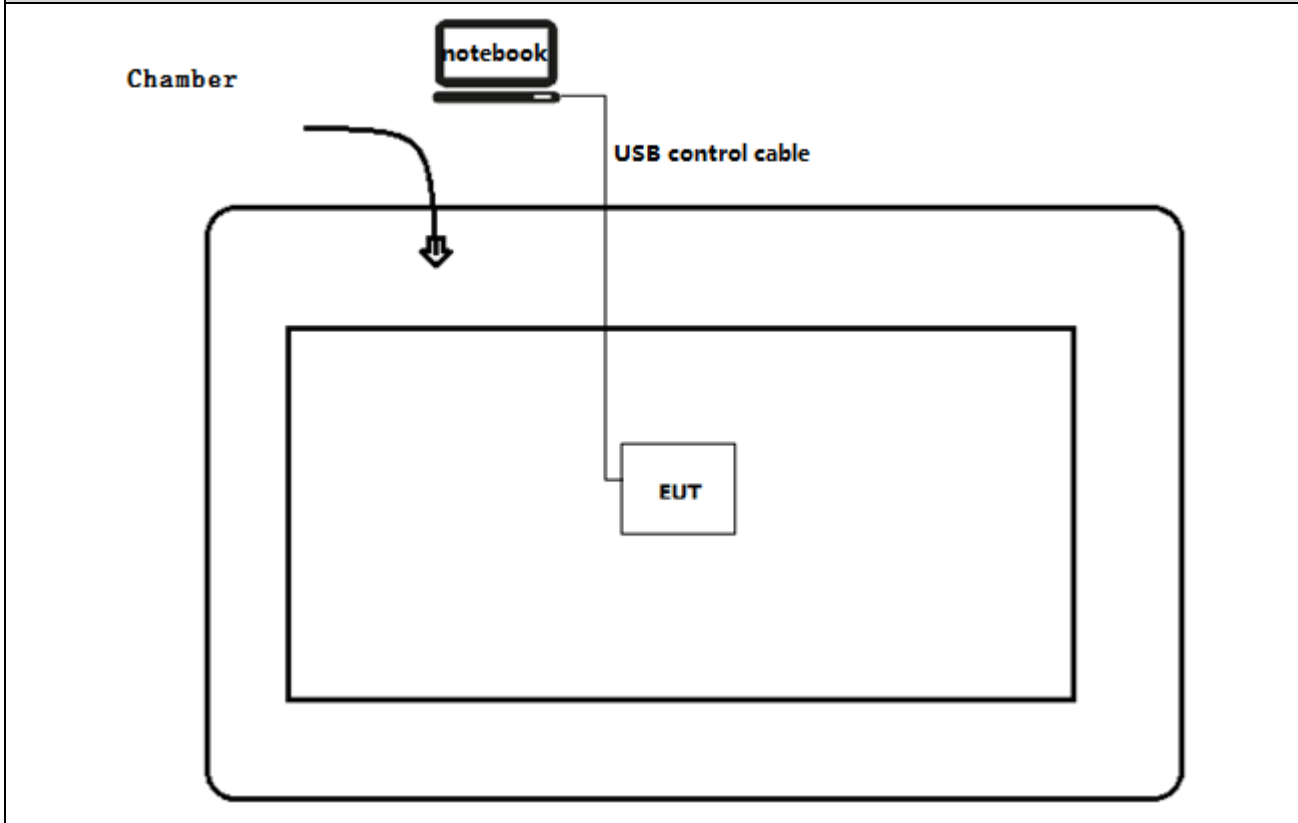

2.4 Testing process

1	Setup the EUT as shown in Section 2.3
2	Run the software “BlueTest3” on the notebook computer.
3	Configure the test mode, test channel, test power and data rate.
4	Verify that the EUT works properly.

3 VERDICT SUMMARY SECTION

This chapter presents an overview of standards and results. Refer to the next chapters for details of measured test results and applied test levels.

3.1 Standards

Standard	Year	Description
FCC CFR Title 47 Part 15 Subpart C Section 15.247	2021	Operation within the bands 902–928 MHz, 2400–2483.5 MHz, and 5725–5850 MHz.
ANSI C63.10	2013	American National Standard of Procedures for Compliance Testing of Unlicensed Wireless Devices
KDB558074 D01 v05r02	2019	Guidance for performing compliance measurements on Digital Transmission System (DTS) operating under section 15.247
RSS-Gen Issue 5 Amendment 2	2021	General Requirements for Compliance of Radio Apparatus
RSS-247 Issue 2	2017	Digital Transmission Systems (DTSs), Frequency Hopping Systems (FHSs) and Licence-Exempt Local Area Network (LE-LAN) Devices

3.2 Deviation(s) from the Standard(s) / Test Specification(s)

The following deviation(s) was / were made from the published requirements of the listed standards: N/A.

(Please define the deviations from the standard(s) if applicable)

3.3 Overview of results

For FCC

Performed Test Item	Normative References	Test Performed	Deviation
Conducted Emission	FCC CFR Title 47 Part 15 Subpart C: 2015Section 15.207	Yes	No
Emissions in restricted frequency bands	FCC CFR Title 47 Part 15 Subpart C: 2015Section 15.209	Yes	No
20dB Bandwidth	FCC CFR Title 47 Part 15 Subpart C: 2015 Section 15.247(a)(1)	Yes	No
Carrier Frequency Separation	FCC CFR Title 47 Part 15 Subpart C: 2015 Section 15.247(a)(1)	Yes	No
Number of Hopping Frequencies	FCC CFR Title 47 Part 15 Subpart C: 2015 Section 15.247(a)(1)(iii)	Yes	No
Time of Occupancy (Dwell Time)	FCC CFR Title 47 Part 15 Subpart C: 2015 Section 15.247(a)(1)(iii)	Yes	No
Peak OutputPower	FCC CFR Title 47 Part 15 Subpart C: 2015 Section 15.247(b)(1)	Yes	No
Emissions in non-restricted frequency bands	FCC CFR Title 47 Part 15 Subpart C: 2015 Section 15.215(c), 15.247(d)	Yes	No
Band Edge	FCC CFR Title 47 Part 15 Subpart C: 2015 15.247(d)	Yes	No
Antenna Requirement	FCC CFR Title 47 Part 15 Subpart C: 2015 Section 15.203	Yes	No

For ISED

Performed Test Item	Normative References	Test Performed	Deviation
Conducted Emission	RSS-Gen Issue 5Section 8.8	Yes	No
Radiated Emission	RSS-Gen Issue 5Section 8.9	Yes	No
20dB Bandwidth	RSS-247 Issue 2 Section 5.1	Yes	No
Carrier Frequency Separation	RSS-247 Issue 2 Section 5.1	Yes	No
Number of Hopping Frequencies	RSS-247 Issue 2 Section 5.1	Yes	No
Time of Occupancy (Dwell Time)	RSS-247 Issue 2 Section 5.1	Yes	No
Peak OutputPower	RSS-247 Issue 2 Section 5.4	Yes	No
Emissions in non-restricted frequency bands	RSS-247 Issue 2 Section 5.5	Yes	No
Band Edge	RSS-Gen Issue 5Section 8.10	Yes	No
Antenna Requirement	RSS-Gen Issue 5Section 8.3	Yes	No

3.4 Test Facility

USA	:	FCC Designation Number: CN1199
CA	:	ISED CAB identifier: CN0040

4 TEST RESULTS

4.1 Conducted Emission	VERDICT: PASS
-------------------------------	----------------------

4.1.1 Limit

Standard	FCC Part 15 Subpart C Paragraph 15.207	
Frequency range [MHz]	Limit: QP [dB(μV) ¹⁾]	Limit: AV [dB(μV) ¹⁾]
0,15 - 0,50	66 - 56 ²⁾	56 - 46 ²⁾
0,50 - 5,0	56	46
5,0 - 30	60	50

¹⁾ At the transition frequency, the lower limit applies.

²⁾ The limit decreases linearly with the logarithm of the frequency.

NOTE 1: The exclusion band for transmitters shall be considered for transmitters operating at frequencies below 30 MHz.

NOTE 2: Where the AC output port is directly connected (or via a circuit breaker) to the AC power input port of the EUT the AC power output port need not to be tested.

4.1.2 Test Setup

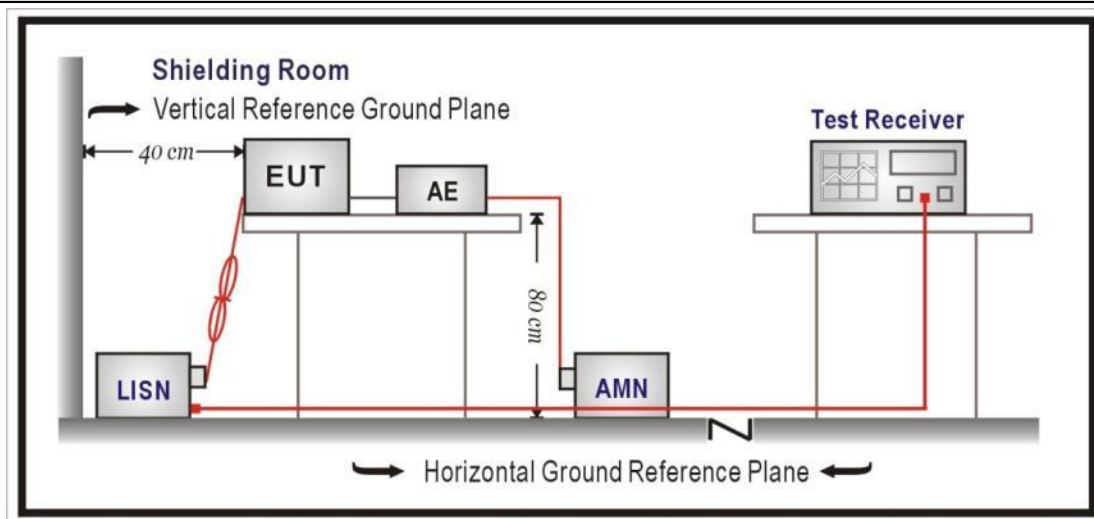

4.1.3 Test Procedure

	References Rule	Chapter	Item
<input checked="" type="checkbox"/>	ANSI C63.10-2013	6.2	Standard test method for ac power-line conducted emissions from unlicensed wireless devices

4.1.4 Test Data

Profile: 2210113R	Page No.: 25
Engineer: Tim.Cao	
Site: TR1	Time: 2022/01/19 - 16:10
Limit: FCC_Part15.107_CE_AC Power_ClassB	Margin: 0
Probe: ENV216_101190(0.009-30MHz)	Polarity: Line
EUT: Bluetooth headset	Power: AC 120V/60Hz
Note: Mode1: Transmit at 2402MHz by DH5	

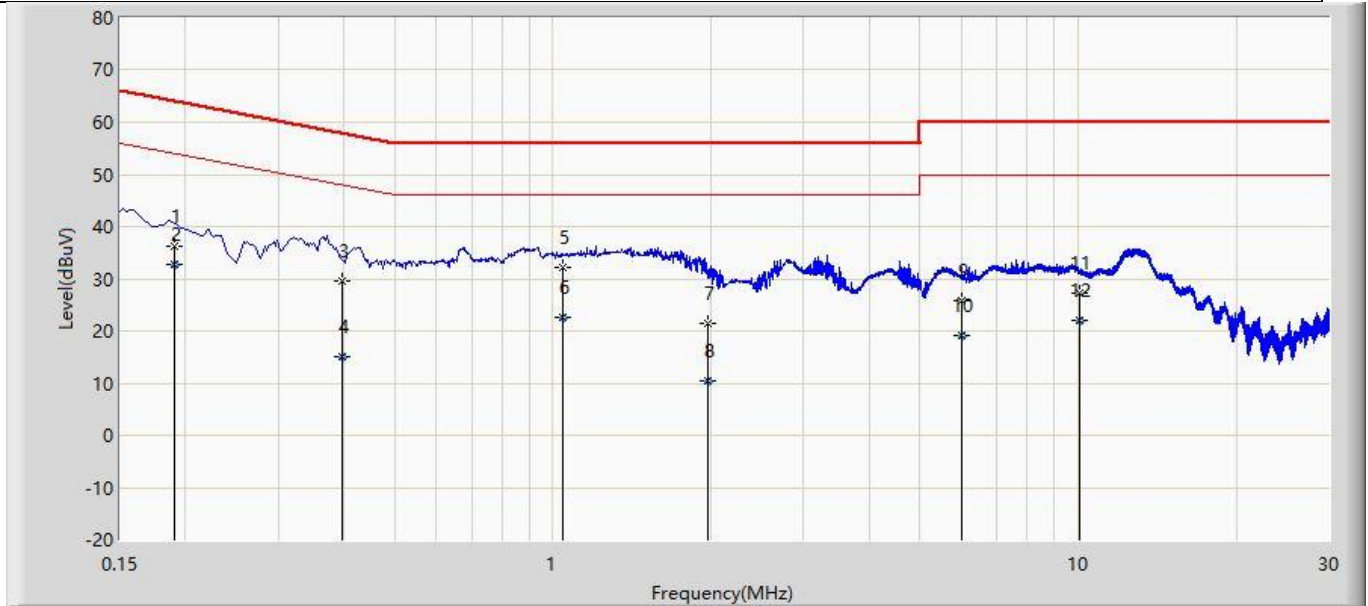

No	Mark	Frequency (MHz)	Measure Level (dBuV)	Reading Level (dBuV)	Over Limit (dB)	Limit (dBuV)	Factor (dB)	Type
1		0.191	36.100	26.515	-27.915	64.015	9.585	QP
2	*	0.191	32.627	23.042	-21.388	54.015	9.585	AV
3		0.398	29.512	19.901	-28.393	57.905	9.612	QP
4		0.398	14.964	5.352	-32.942	47.905	9.612	AV
5		1.041	32.250	22.601	-23.750	56.000	9.650	QP
6		1.041	22.666	13.016	-23.334	46.000	9.650	AV
7		1.970	21.510	11.835	-34.490	56.000	9.675	QP
8		1.970	10.540	0.865	-35.460	46.000	9.675	AV
9		6.013	25.909	16.047	-34.091	60.000	9.861	QP
10		6.013	19.135	9.274	-30.865	50.000	9.861	AV
11		10.084	27.351	17.338	-32.649	60.000	10.012	QP
12		10.084	21.971	11.958	-28.029	50.000	10.012	AV

Profile: 2210113R	Page No.: 26
Engineer: Tim.Cao	
Site: TR1	Time: 2022/01/19 - 16:11
Limit: FCC_Part15.107_CE_AC Power_ClassB	Margin: 0
Probe: ENV216_101190(0.009-30MHz)	Polarity: Line
EUT: Bluetooth headset	Power: AC 120V/60Hz
Note: Mode1: Transmit at 2402MHz by DH5	

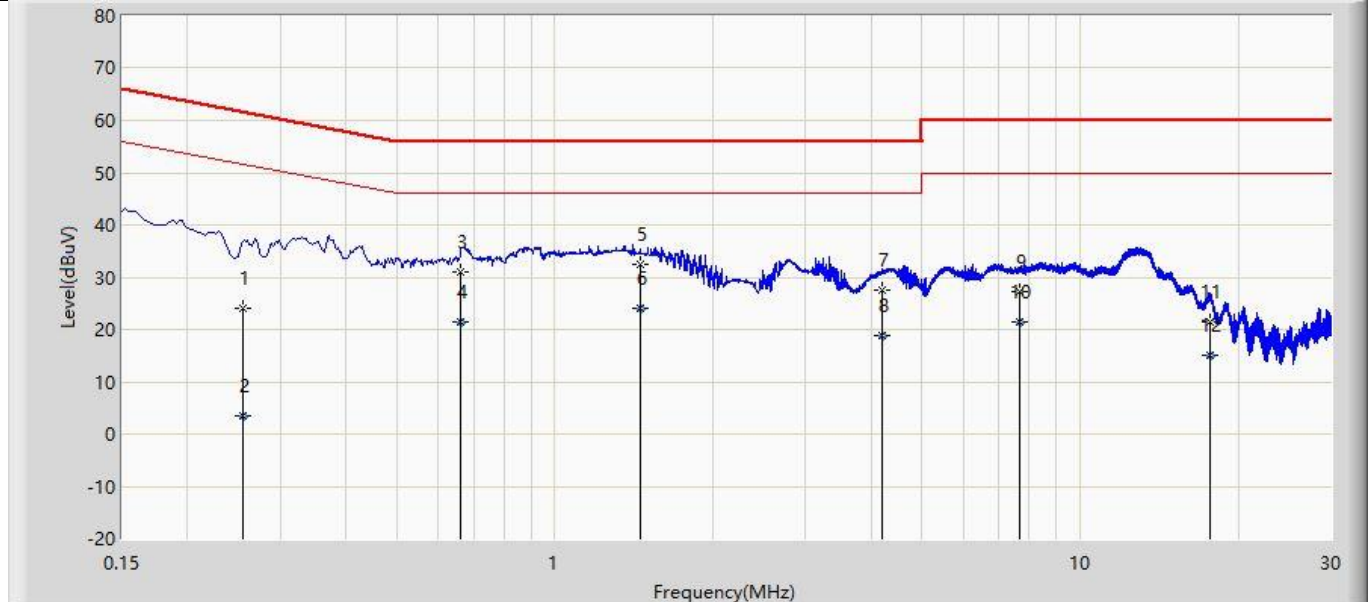

No	Mark	Frequency (MHz)	Measure Level (dBuV)	Reading Level (dBuV)	Over Limit (dB)	Limit (dBuV)	Factor (dB)	Type
1		0.254	23.976	14.382	-37.666	61.642	9.594	QP
2		0.254	3.558	-6.036	-48.084	51.642	9.594	AV
3		0.663	30.922	21.287	-25.078	56.000	9.636	QP
4		0.663	21.367	11.731	-24.633	46.000	9.636	AV
5		1.457	32.606	22.944	-23.394	56.000	9.661	QP
6	*	1.457	23.952	14.291	-22.048	46.000	9.661	AV
7		4.205	27.442	17.662	-28.558	56.000	9.780	QP
8		4.205	18.867	9.087	-27.133	46.000	9.780	AV
9		7.670	27.234	17.301	-32.766	60.000	9.932	QP
10		7.670	21.485	11.552	-28.515	50.000	9.932	AV
11		17.608	21.401	11.216	-38.599	60.000	10.185	QP
12		17.608	14.951	4.766	-35.049	50.000	10.185	AV

4.2 Emissions in restricted frequency bands	VERDICT: PASS
--	----------------------

4.2.1 Limit

Standard	FCC Part 15 Subpart C Paragraph 15.209
-----------------	--

Restricted Bands of operation for FCC

Frequency (MHz)	Frequency (MHz)	Frequency (MHz)	Frequency (GHz)
0.090 – 0.110	16.42 – 16.423	399.9 – 410	4.5 – 5.15
0.495 – 0.505	16.69475 – 16.69525	608 – 614	5.35 – 5.46
2.1735 – 2.1905	16.80425 – 16.80475	960 – 1240	7.25 – 7.75
4.125 – 4.128	25.5 – 25.67	1300 – 1427	8.025 – 8.5
4.17725 – 4.17775	37.5 – 38.25	1435 – 1626.5	9.0 – 9.2
4.20725 – 4.20775	73 – 74.6	1645.5 – 1646.5	9.3 – 9.5
6.215 – 6.218	74.8 – 75.2	1660 – 1710	10.6 – 12.7
6.26775 – 6.26825	108 – 121.94	1718.8 – 1722.2	13.25 – 13.4
6.31175 – 6.31225	123 – 138	2200 – 2300	14.47 – 14.5
8.291 – 8.294	149.9 – 150.05	2310 – 2390	15.35 – 16.2
8.362 – 8.366	156.52475 – 156.52525	2483.5 – 2500	17.7 – 21.4
8.37625 – 8.38675	156.7 – 156.9	2690 – 2900	22.01 – 23.12
8.81425 – 8.81475	162.0125 – 167.17	3260 – 3267	23.6 – 24.0
12.29 – 12.293	167.72 – 173.2	3332 – 3339	31.2 – 31.8
12.51975 – 12.52025	240 – 285	3345.8 – 3358	36.43 – 36.5
12.57675 – 12.57725	322 – 335.4	3600 – 4400	
13.36 – 13.41			

Restricted Bands of operation for ISED

0.090 - 0.110	13.36 - 13.41	960 - 1427	9.0 - 9.2
0.495 - 0.505	16.42 - 16.423	1435 - 1626.5	9.3 - 9.5
2.1735 - 2.1905	16.69475 - 16.69525	1645.5 - 1646.5	10.6 - 12.7
3.020 - 3.026	16.80425 - 16.80475	1660 - 1710	13.25 - 13.4
4.125 - 4.128	25.5 - 25.67	1718.8 - 1722.2	14.47 - 14.5
4.17725 - 4.17775	37.5 - 38.25	2200 - 2300	15.35 - 16.2
4.20725 - 4.20775	73 - 74.6	2310 - 2390	17.7 - 21.4
5.677 - 5.683	74.8 - 75.2	2483.5 - 2500	22.01 - 23.12
6.215 - 6.218	108 - 138	2655 - 2900	23.6 - 24.0
6.26775 - 6.26825	149.9 - 150.05	3260 - 3267	31.2 - 31.8
6.31175 - 6.31225	156.52475 - 156.52525	3332 - 3339	36.43 - 36.5
8.291 - 8.294	156.7 - 156.9	3345.8 - 3358	Above 38.6
8.362 - 8.366	162.0125 - 167.17	3500 - 4400	
8.37625 - 8.38675	167.72 - 173.2	4500 - 5150	
8.41425 - 8.41475	240 - 285	5350 - 5460	
12.29 - 12.293	322 - 335.4	7250 - 7750	
12.51975 - 12.52025	399.9 - 410	8025 - 8500	
12.57675 - 12.57725	608 - 614	--	

Restricted Band Emissions Limit			
Frequency (MHz)	Field strength ($\mu\text{V}/\text{m}$)	Field strength ($\text{dB}\mu\text{V}/\text{m}$)	Measurement distance (m)
0.009 - 0.49	2400/F(kHz)	48.5 – 13.8	300 _(Note 1)
0.49 - 1.705	24000/F(kHz)	33.8 - 23	30 _(Note 1)
1.705 - 30	30	29.5	30 _(Note 1)
30 -88	100	40	3 _(Note 2)
88-216	150	43.5	3 _(Note 2)
216 - 960	200	46	3 _(Note 2)
Above 960	500	54	3 _(Note 2)

Note 1: At frequencies below 30 MHz, measurements may be performed at a distance closer than that specified in the regulations; however, an attempt should be made to avoid making measurements in the near field. Pending the development of an appropriate measurement procedure for measurements performed below 30 MHz, when performing measurements at a closer distance than specified, the results shall be extrapolated to the specified distance by either making measurements at a minimum of two distances on at least one radial to determine the proper extrapolation factor or by using the square of an inverse linear distance extrapolation factor (40 dB/decade).

Note 2: At frequencies at or above 30 MHz, measurements may be performed at a distance other than what is specified provided: measurements are not made in the near field except where it can be shown that near field measurements are appropriate due to the characteristics of the device; and it can be demonstrated that the signal levels needed to be measured at the distance employed can be detected by the measurement equipment. Measurements shall not be performed at a distance greater than 30 meters unless it can be further demonstrated that measurements at a distance of 30 meters or less are impractical. When performing measurements at a distance other than that specified, the results shall be extrapolated to the specified distance using an extrapolation factor of 20 dB/decade (inverse linear-distance for field strength measurements; inverse-linear-distance-squared for power density measurements).

4.2.2 Test Setup

Below 30MHz Test Setup:

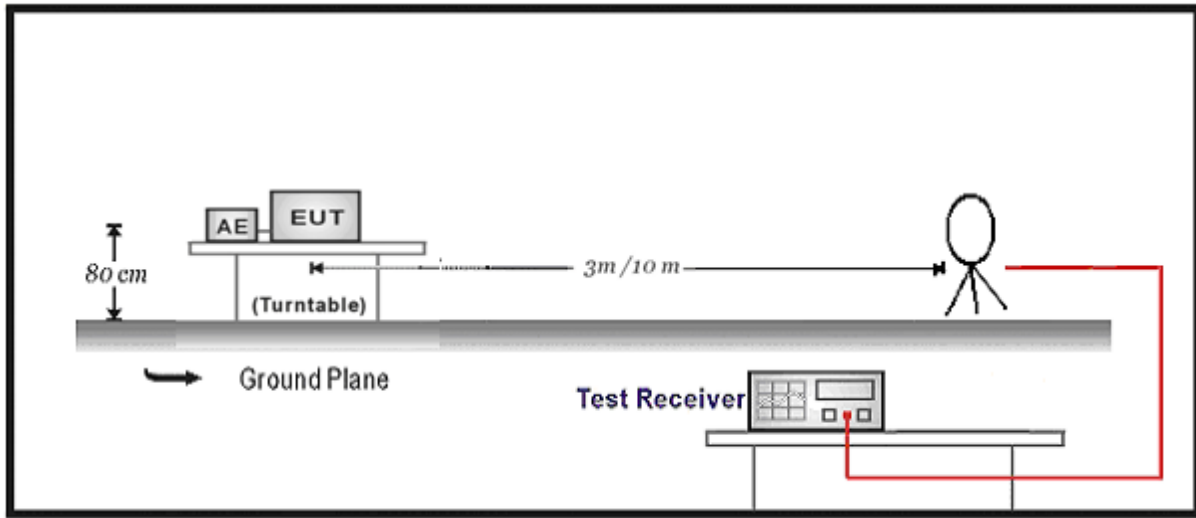

30MHz-1GHz Test Setup:

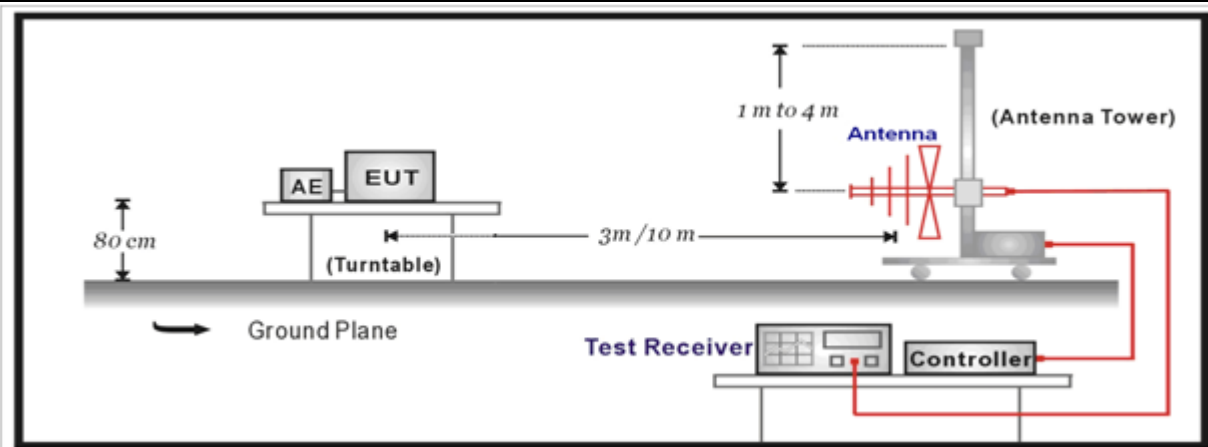

Above 1GHz Test Setup:

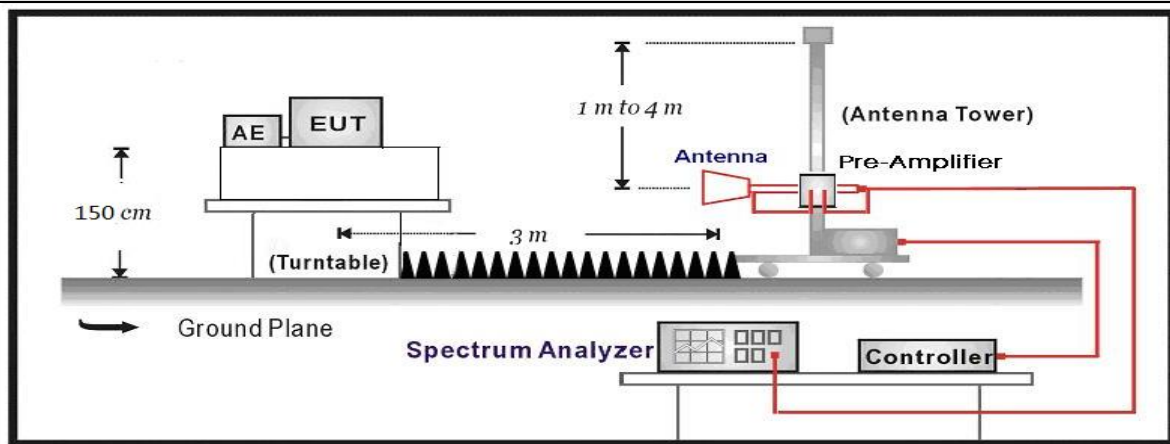

4.2.3 Test Procedure			
	References Rule	Chapter	Description
<input checked="" type="checkbox"/>	ANSI C63.10	11.12	Emissions in restricted frequency bands
<input checked="" type="checkbox"/>	ANSI C63.10	11.12.1	Radiated emission measurements
<input checked="" type="checkbox"/>	ANSI C63.10	11.12.2.7	Radiated spurious emission test
<input checked="" type="checkbox"/>	ANSI C63.10	6.4	Radiated emissions from unlicensed wireless devices below 30 MHz
<input checked="" type="checkbox"/>	ANSI C63.10	6.5	Radiated emissions from unlicensed wireless devices in the frequency range of 30 MHz to 1000 MHz
<input checked="" type="checkbox"/>	ANSI C63.10	6.6	Radiated emissions from unlicensed wireless devices above 1 GHz

4.2.4 Test Data

Profile: 2210113R	Page No.: 121
Engineer: Juliuszhou	
Site: AC5	Time: 2022/01/19 - 14:02
Limit: FCC_Part15.209_RE(3m)	Margin: 0
Probe: Horn_3117_00123988_(1-18GHz)	Polarity: Horizontal
EUT: BLUETOOTH HEADSET	Power: AC 120V/60Hz
Note: Mode 1:Transmit at 2402MHz by DH5	

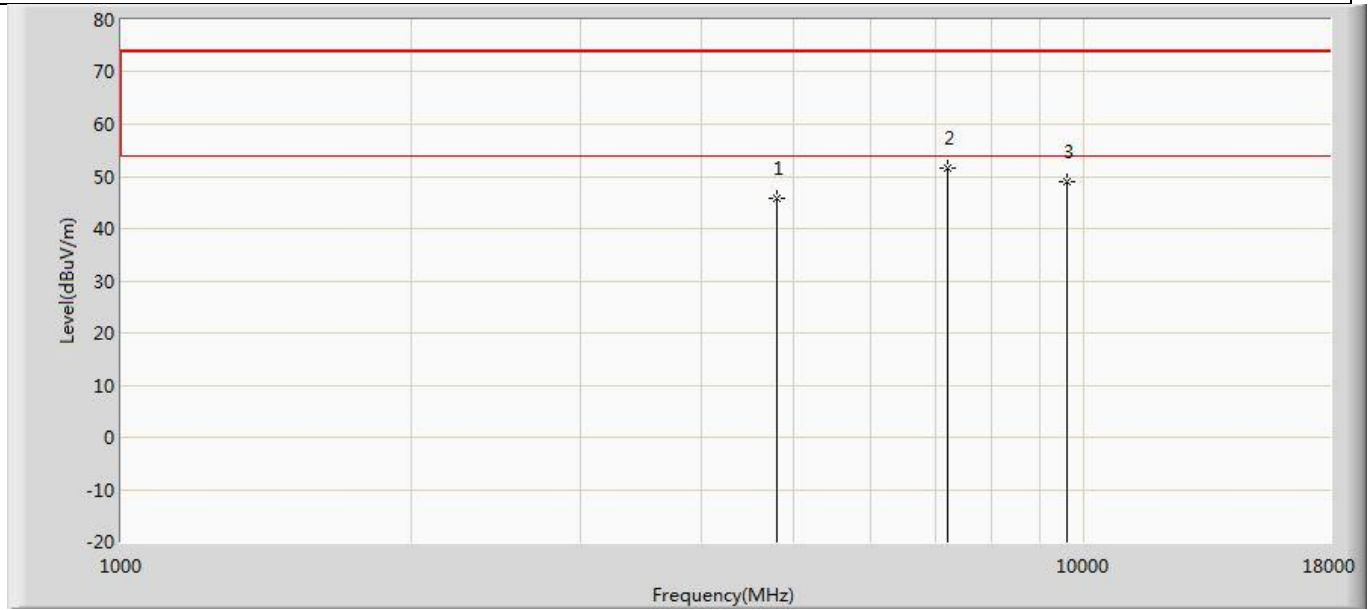

No	Mark	Frequency (MHz)	Measure Level (dBuV/m)	Reading Level (dBuV)	Over Limit (dB)	Limit (dBuV/m)	Factor (dB)	Type
1		4804.000	45.849	51.991	-28.151	74.000	-6.143	PK
2	*	7205.000	51.686	53.992	-22.314	74.000	-2.306	PK
3		9608.000	48.979	46.528	-25.021	74.000	2.451	PK

Profile: 2210113R	Page No.: 122
Engineer: Juliuszhou	
Site: AC5	Time: 2022/01/19 - 14:02
Limit: FCC_Part15.209_RE(3m)	Margin: 0
Probe: Horn_3117_00123988_(1-18GHz)	Polarity: Vertical
EUT: BLUETOOTH HEADSET	Power: AC 120V/60Hz
Note: Mode 1:Transmit at 2402MHz by DH5	

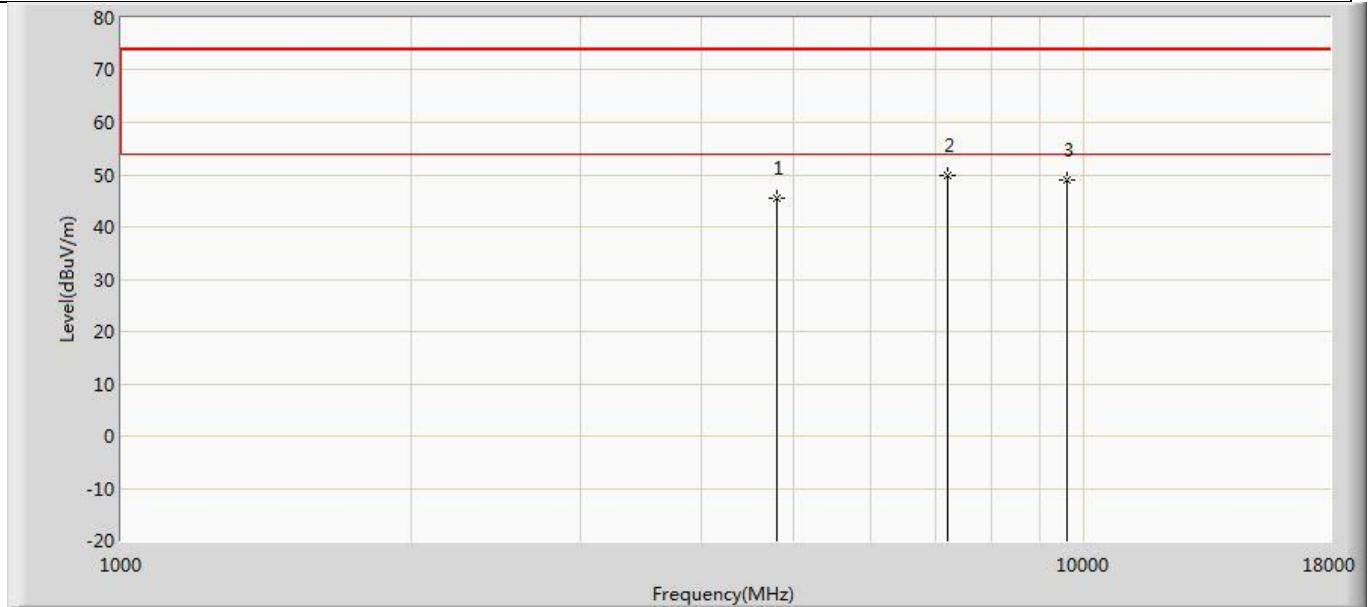

No	Mark	Frequency (MHz)	Measure Level (dBuV/m)	Reading Level (dBuV)	Over Limit (dB)	Limit (dBuV/m)	Factor (dB)	Type
1		4804.000	45.399	51.541	-28.601	74.000	-6.143	PK
2	*	7205.000	49.962	52.268	-24.038	74.000	-2.306	PK
3		9608.000	49.041	46.590	-24.959	74.000	2.451	PK

Profile: 2210113R	Page No.: 123
Engineer: Juliuszhou	
Site: AC5	Time: 2022/01/19 - 14:02
Limit: FCC_Part15.209_RE(3m)	Margin: 0
Probe: Horn_3117_00123988_(1-18GHz)	Polarity: Horizontal
EUT: BLUETOOTH HEADSET	Power: AC 120V/60Hz
Note: Mode 1:Transmit at 2441MHz by DH5	

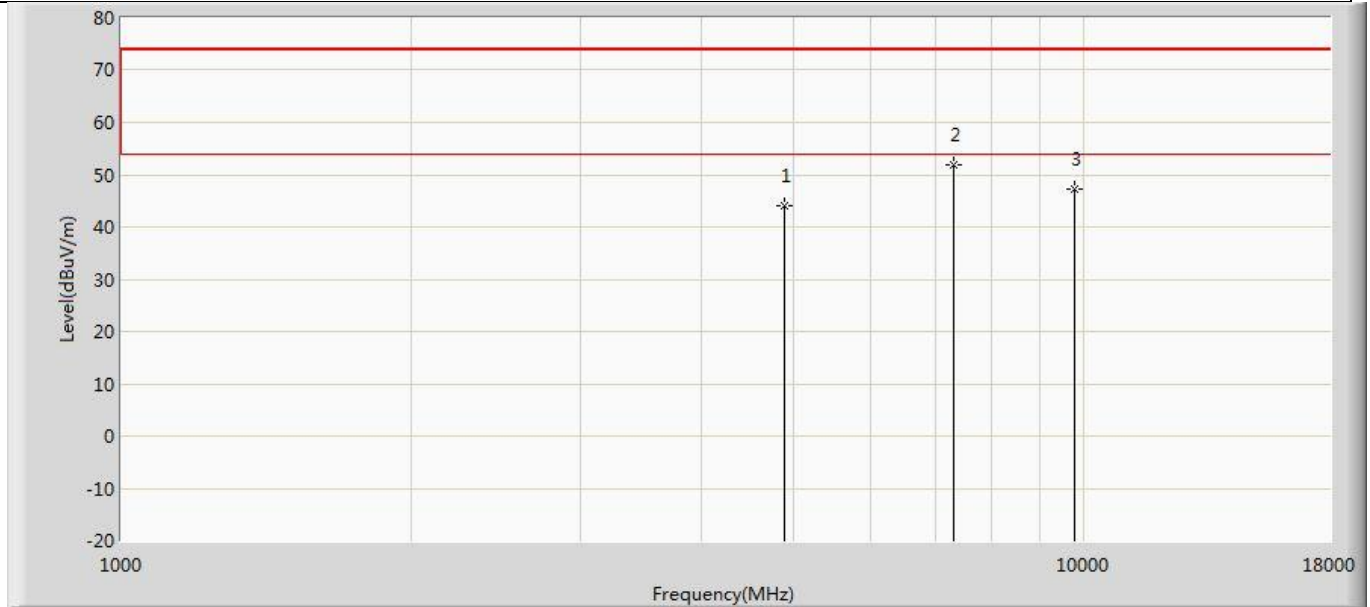

No	Mark	Frequency (MHz)	Measure Level (dBuV/m)	Reading Level (dBuV)	Over Limit (dB)	Limit (dBuV/m)	Factor (dB)	Type
1		4882.000	44.029	49.808	-29.971	74.000	-5.779	PK
2	*	7324.000	52.014	54.307	-21.986	74.000	-2.293	PK
3		9764.000	47.332	46.103	-26.668	74.000	1.229	PK

Profile: 2210113R	Page No.: 124
Engineer: Juliuszhou	
Site: AC5	Time: 2022/01/19 - 14:03
Limit: FCC_Part15.209_RE(3m)	Margin: 0
Probe: Horn_3117_00123988_(1-18GHz)	Polarity: Vertical
EUT: BLUETOOTH HEADSET	Power: AC 120V/60Hz
Note: Mode 1:Transmit at 244MHz by DH5	

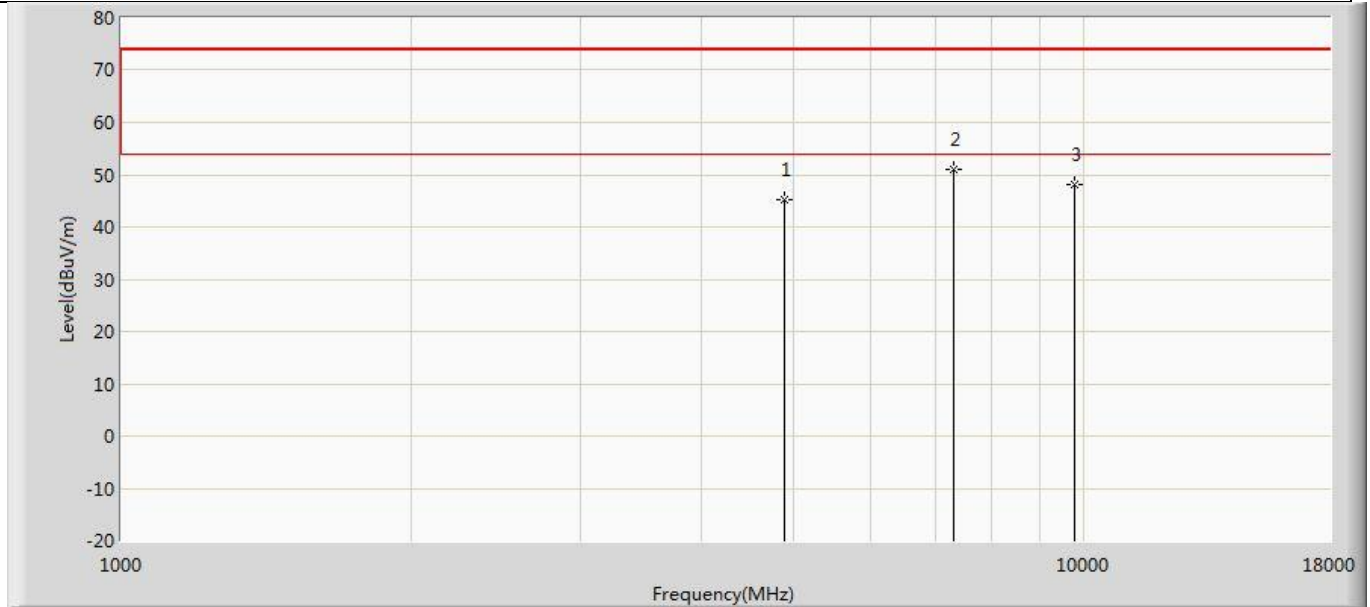

No	Mark	Frequency (MHz)	Measure Level (dBuV/m)	Reading Level (dBuV)	Over Limit (dB)	Limit (dBuV/m)	Factor (dB)	Type
1		4882.000	45.152	50.931	-28.848	74.000	-5.779	PK
2	*	7324.000	50.963	53.256	-23.037	74.000	-2.293	PK
3		9764.000	48.181	46.952	-25.819	74.000	1.229	PK

Profile: 2210113R	Page No.: 125
Engineer: Juliuszhou	
Site: AC5	Time: 2022/01/19 - 14:03
Limit: FCC_Part15.209_RE(3m)	Margin: 0
Probe: Horn_3117_00123988_(1-18GHz)	Polarity: Horizontal
EUT: BLUETOOTH HEADSET	Power: AC 120V/60Hz
Note: Mode 1:Transmit at 2480MHz by DH5	

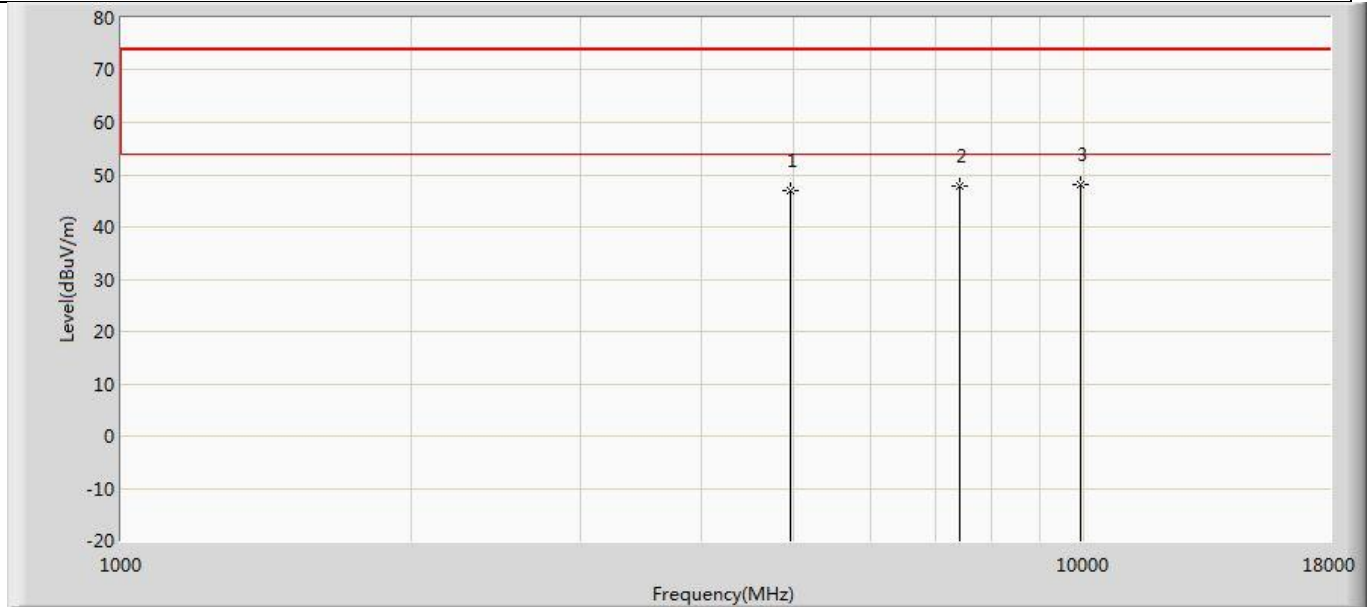

No	Mark	Frequency (MHz)	Measure Level (dBuV/m)	Reading Level (dBuV)	Over Limit (dB)	Limit (dBuV/m)	Factor (dB)	Type
1		4960.000	46.873	52.239	-27.127	74.000	-5.365	PK
2		7440.000	47.766	50.629	-26.234	74.000	-2.863	PK
3	*	9920.000	48.205	47.289	-25.795	74.000	0.916	PK

Profile: 2210113R	Page No.: 126
Engineer: Juliuszhou	
Site: AC5	Time: 2022/01/19 - 14:03
Limit: FCC_Part15.209_RE(3m)	Margin: 0
Probe: Horn_3117_00123988_(1-18GHz)	Polarity: Vertical
EUT: BLUETOOTH HEADSET	Power: AC 120V/60Hz
Note: Mode 1:Transmit at 2480MHz by DH5	

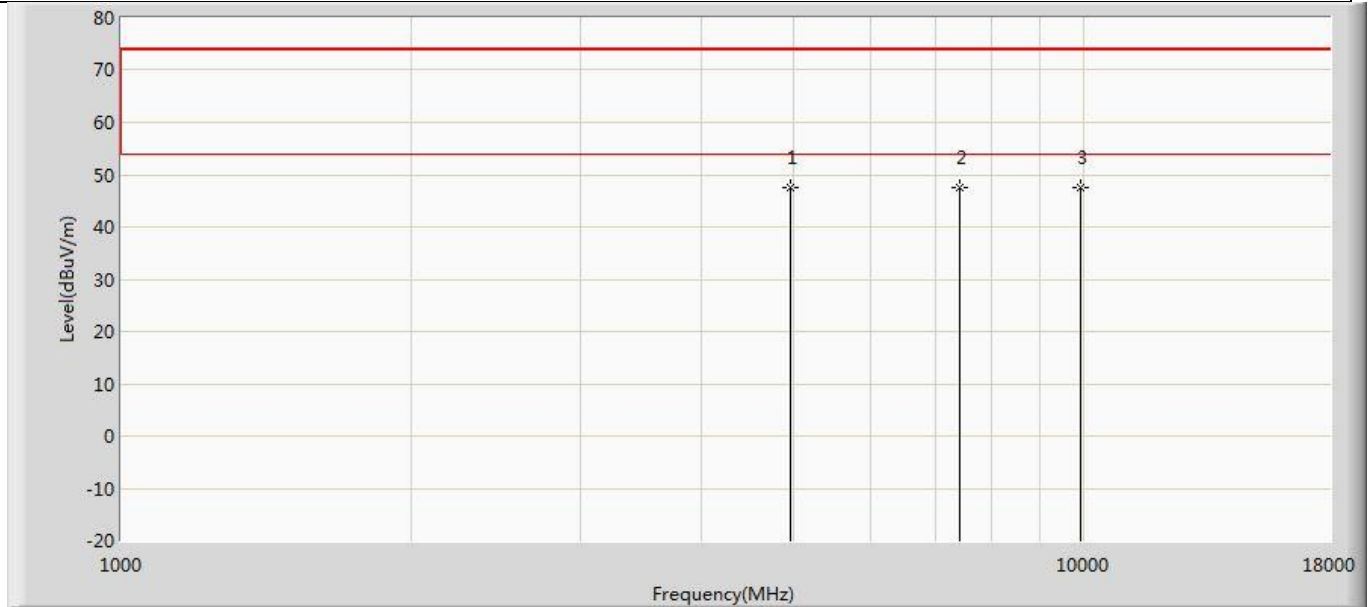

No	Mark	Frequency (MHz)	Measure Level (dBuV/m)	Reading Level (dBuV)	Over Limit (dB)	Limit (dBuV/m)	Factor (dB)	Type
1		4960.000	47.457	52.823	-26.543	74.000	-5.365	PK
2	*	7440.000	47.630	50.493	-26.370	74.000	-2.863	PK
3		9920.000	47.506	46.590	-26.494	74.000	0.916	PK

Profile: 2210113R	Page No.: 127
Engineer: Juliuszhou	
Site: AC5	Time: 2022/01/19 - 14:03
Limit: FCC_Part15.209_RE(3m)	Margin: 0
Probe: Horn_3117_00123988_(1-18GHz)	Polarity: Horizontal
EUT: BLUETOOTH HEADSET	Power: AC 120V/60Hz
Note: Mode 2:Transmit at 2402MHz by 2DH5	

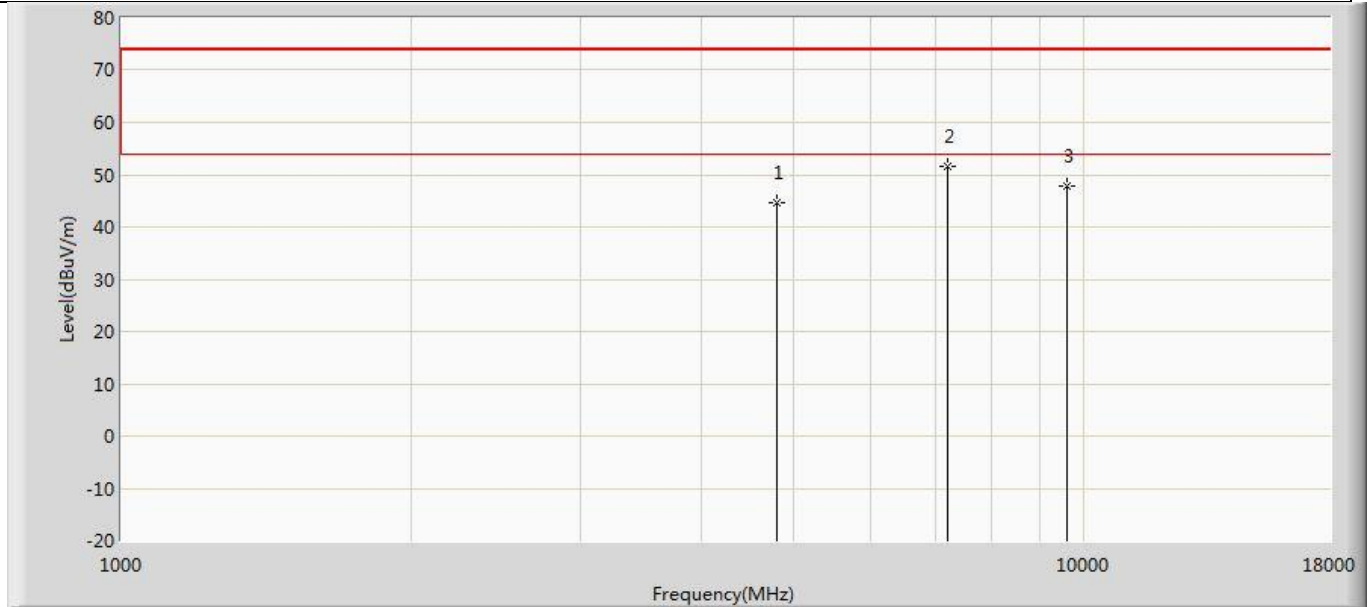

No	Mark	Frequency (MHz)	Measure Level (dBuV/m)	Reading Level (dBuV)	Over Limit (dB)	Limit (dBuV/m)	Factor (dB)	Type
1		4804.000	44.638	50.780	-29.362	74.000	-6.143	PK
2	*	7205.000	51.623	53.929	-22.377	74.000	-2.306	PK
3		9608.000	47.960	45.509	-26.040	74.000	2.451	PK

Profile: 2210113R	Page No.: 128
Engineer: Juliuszhou	
Site: AC5	Time: 2022/01/19 - 14:03
Limit: FCC_Part15.209_RE(3m)	Margin: 0
Probe: Horn_3117_00123988_(1-18GHz)	Polarity: Vertical
EUT: BLUETOOTH HEADSET	Power: AC 120V/60Hz
Note: Mode 2:Transmit at 2402MHz by 2DH5	

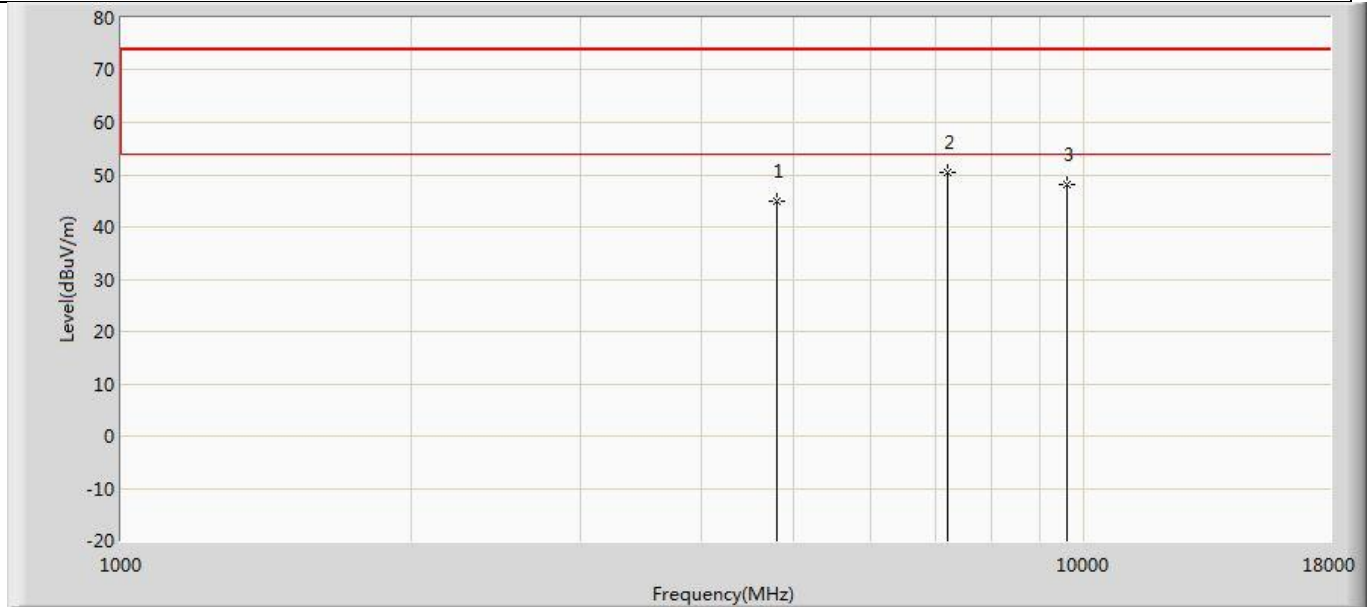

No	Mark	Frequency (MHz)	Measure Level (dBuV/m)	Reading Level (dBuV)	Over Limit (dB)	Limit (dBuV/m)	Factor (dB)	Type
1		4804.000	44.860	51.002	-29.140	74.000	-6.143	PK
2	*	7205.000	50.532	52.838	-23.468	74.000	-2.306	PK
3		9608.000	47.982	45.531	-26.018	74.000	2.451	PK

Profile: 2210113R	Page No.: 129
Engineer: Juliuszhou	
Site: AC5	Time: 2022/01/19 - 14:03
Limit: FCC_Part15.209_RE(3m)	Margin: 0
Probe: Horn_3117_00123988_(1-18GHz)	Polarity: Horizontal
EUT: BLUETOOTH HEADSET	Power: AC 120V/60Hz
Note: Mode 2:Transmit at 2441MHz by 2DH5	

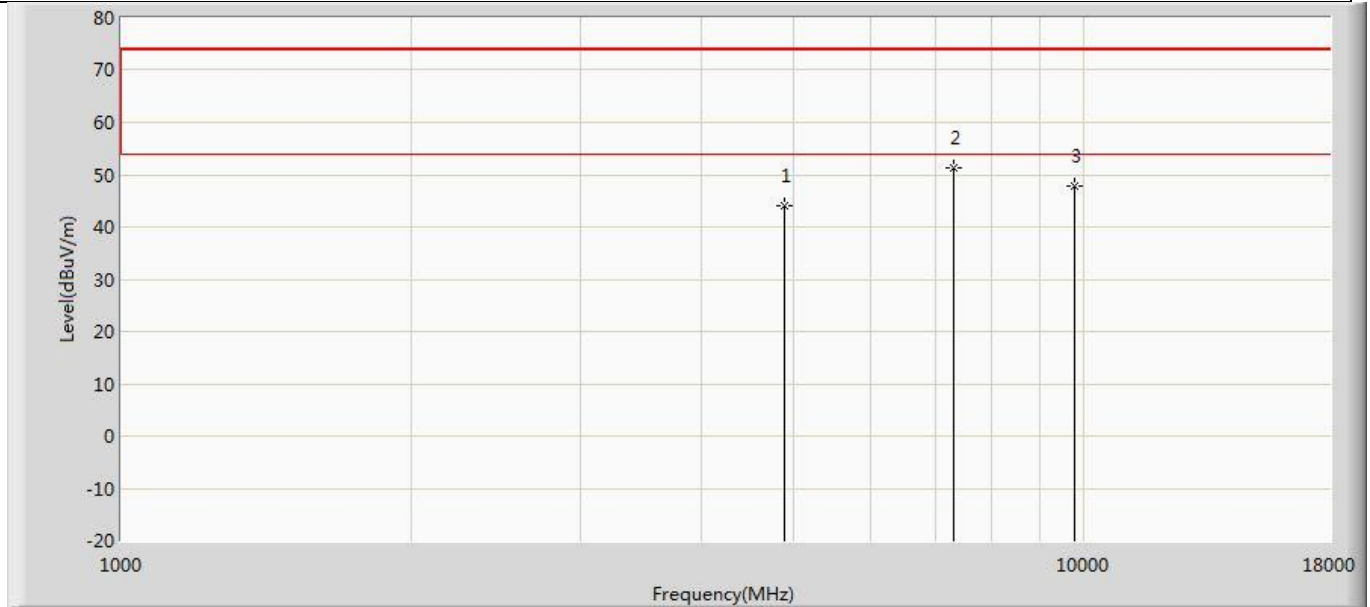

No	Mark	Frequency (MHz)	Measure Level (dBuV/m)	Reading Level (dBuV)	Over Limit (dB)	Limit (dBuV/m)	Factor (dB)	Type
1		4882.000	43.948	49.727	-30.052	74.000	-5.779	PK
2	*	7324.000	51.226	53.519	-22.774	74.000	-2.293	PK
3		9764.000	47.751	46.522	-26.249	74.000	1.229	PK

Profile: 2210113R	Page No.: 130
Engineer: Juliuszhou	
Site: AC5	Time: 2022/01/19 - 14:03
Limit: FCC_Part15.209_RE(3m)	Margin: 0
Probe: Horn_3117_00123988_(1-18GHz)	Polarity: Vertical
EUT: BLUETOOTH HEADSET	Power: AC 120V/60Hz
Note: Mode 2:Transmit at 2441MHz by 2DH5	

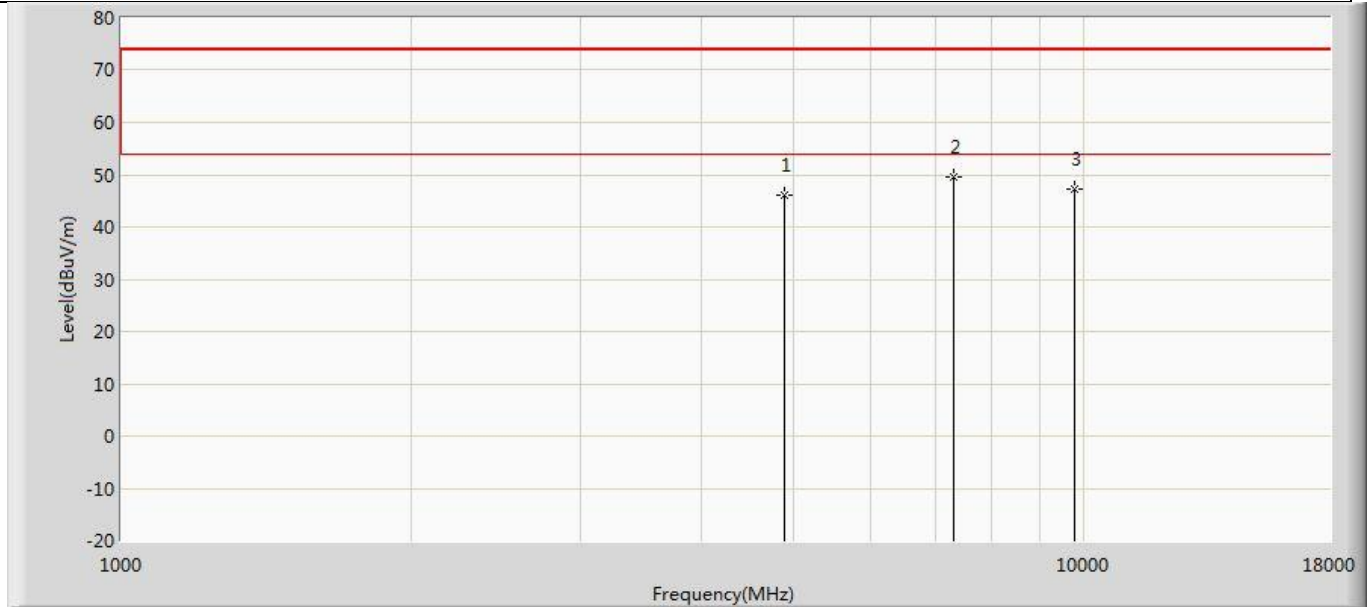

No	Mark	Frequency (MHz)	Measure Level (dBuV/m)	Reading Level (dBuV)	Over Limit (dB)	Limit (dBuV/m)	Factor (dB)	Type
1		4882.000	46.155	51.934	-27.845	74.000	-5.779	PK
2	*	7324.000	49.547	51.840	-24.453	74.000	-2.293	PK
3		9764.000	47.144	45.915	-26.856	74.000	1.229	PK

Profile: 2210113R	Page No.: 131
Engineer: Juliuszhou	
Site: AC5	Time: 2022/01/19 - 14:03
Limit: FCC_Part15.209_RE(3m)	Margin: 0
Probe: Horn_3117_00123988_(1-18GHz)	Polarity: Horizontal
EUT: BLUETOOTH HEADSET	Power: AC 120V/60Hz
Note: Mode 2:Transmit at 2480MHz by 2DH5	

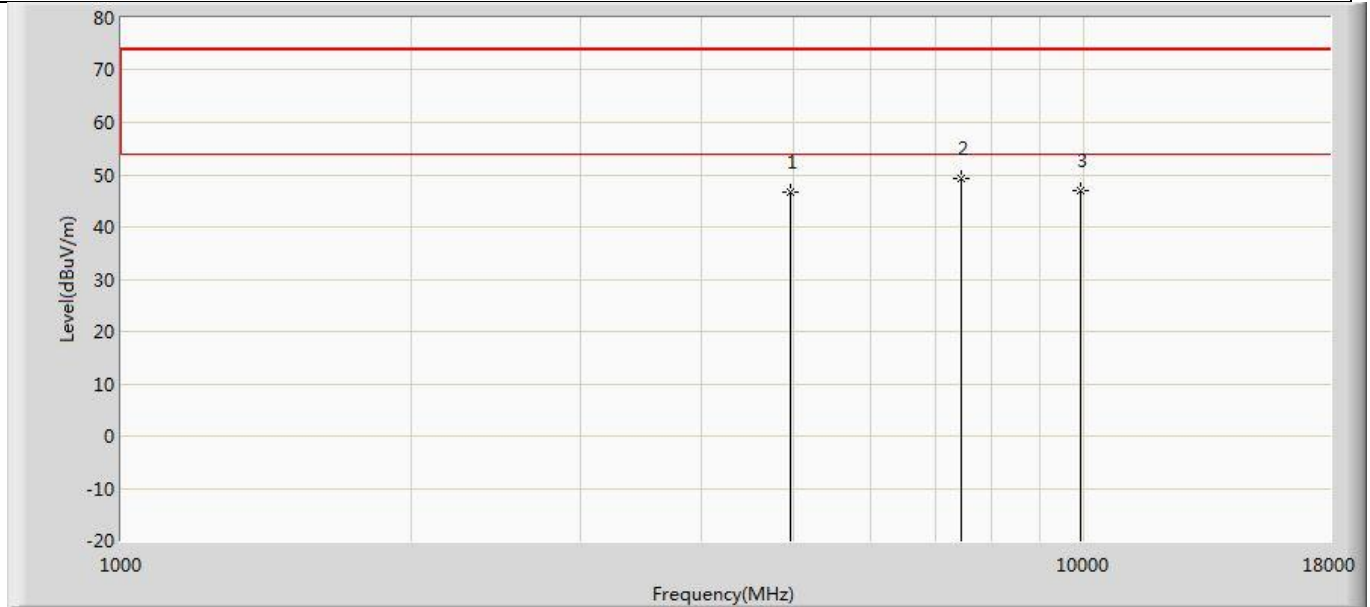

No	Mark	Frequency (MHz)	Measure Level (dBuV/m)	Reading Level (dBuV)	Over Limit (dB)	Limit (dBuV/m)	Factor (dB)	Type
1		4960.000	46.631	51.997	-27.369	74.000	-5.365	PK
2	*	7443.000	49.139	52.076	-24.861	74.000	-2.937	PK
3		9920.000	46.821	45.905	-27.179	74.000	0.916	PK

Profile: 2210113R	Page No.: 132
Engineer: Juliuszhou	
Site: AC5	Time: 2022/01/19 - 14:03
Limit: FCC_Part15.209_RE(3m)	Margin: 0
Probe: Horn_3117_00123988_(1-18GHz)	Polarity: Vertical
EUT: BLUETOOTH HEADSET	Power: AC 120V/60Hz
Note: Mode 2:Transmit at 2480MHz by 2DH5	

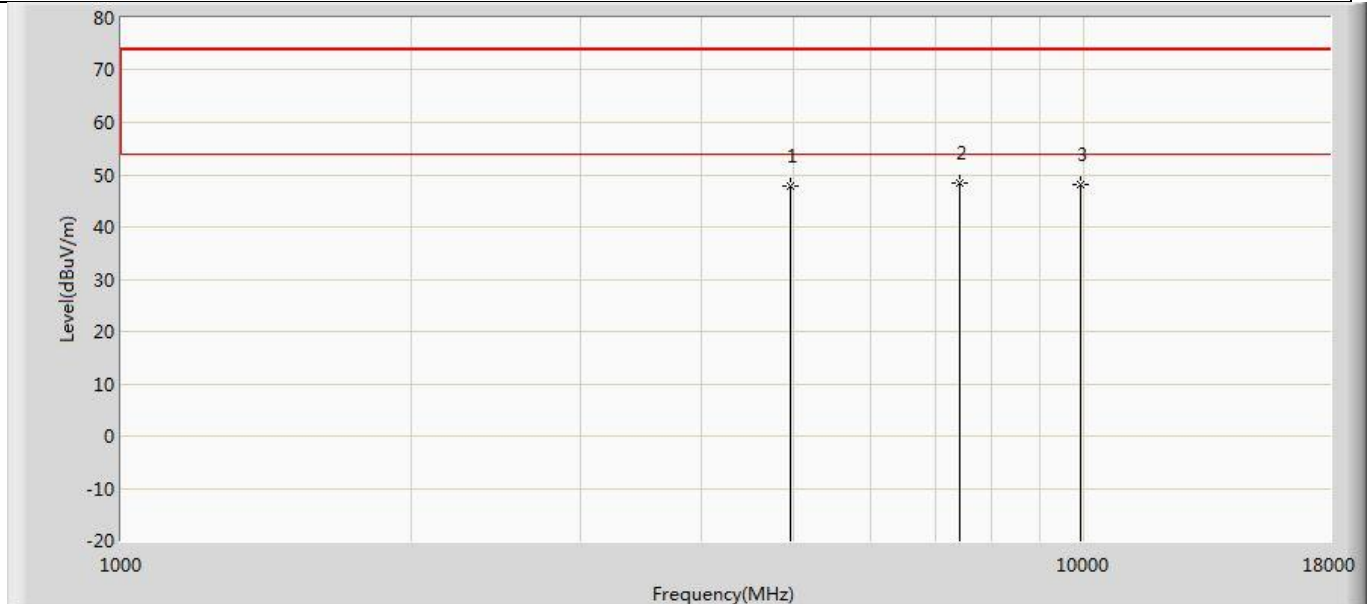

No	Mark	Frequency (MHz)	Measure Level (dBuV/m)	Reading Level (dBuV)	Over Limit (dB)	Limit (dBuV/m)	Factor (dB)	Type
1		4961.000	47.787	53.139	-26.213	74.000	-5.352	PK
2	*	7440.000	48.343	51.206	-25.657	74.000	-2.863	PK
3		9920.000	47.995	47.079	-26.005	74.000	0.916	PK

Profile: 2210113R	Page No.: 133
Engineer: Juliuszhou	
Site: AC5	Time: 2022/01/19 - 14:03
Limit: FCC_Part15.209_RE(3m)	Margin: 0
Probe: Horn_3117_00123988_(1-18GHz)	Polarity: Horizontal
EUT: BLUETOOTH HEADSET	Power: AC 120V/60Hz
Note: Mode 3:Transmit at 2402MHz by 3DH5	

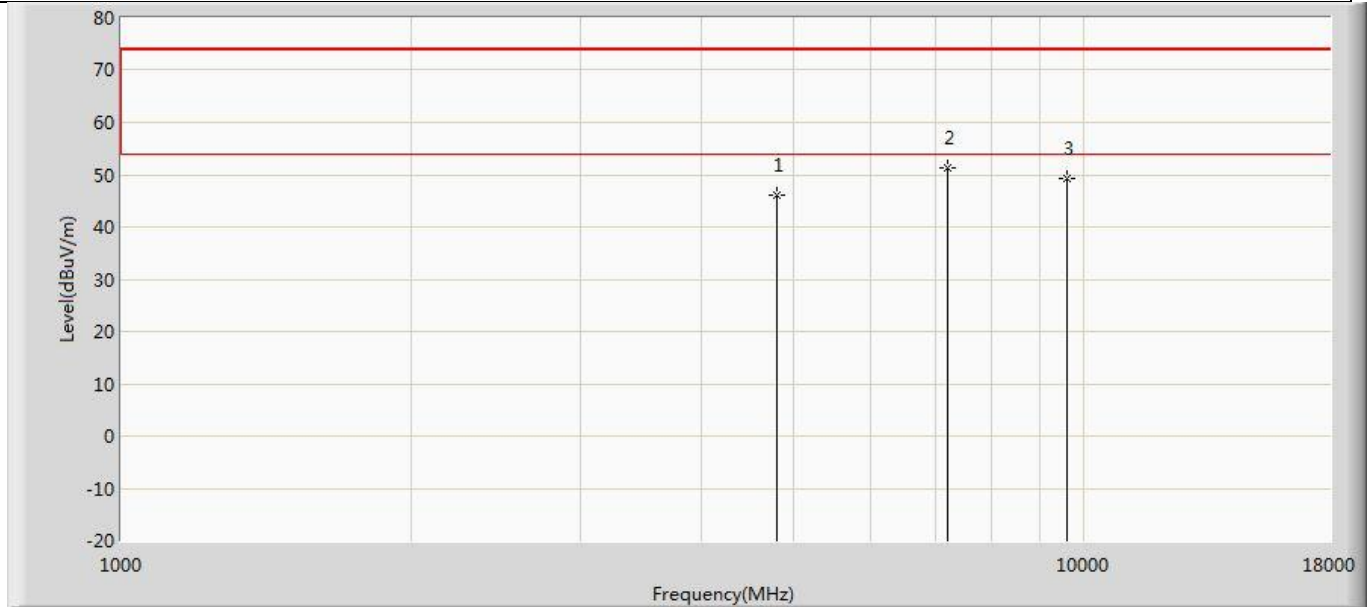

No	Mark	Frequency (MHz)	Measure Level (dBuV/m)	Reading Level (dBuV)	Over Limit (dB)	Limit (dBuV/m)	Factor (dB)	Type
1		4802.000	46.034	52.191	-27.966	74.000	-6.156	PK
2	*	7205.000	51.373	53.679	-22.627	74.000	-2.306	PK
3		9608.000	49.195	46.744	-24.805	74.000	2.451	PK

Profile: 2210113R	Page No.: 134
Engineer: Juliuszhou	
Site: AC5	Time: 2022/01/19 - 14:03
Limit: FCC_Part15.209_RE(3m)	Margin: 0
Probe: Horn_3117_00123988_(1-18GHz)	Polarity: Vertical
EUT: BLUETOOTH HEADSET	Power: AC 120V/60Hz
Note: Mode 3:Transmit at 2402MHz by 3DH5	

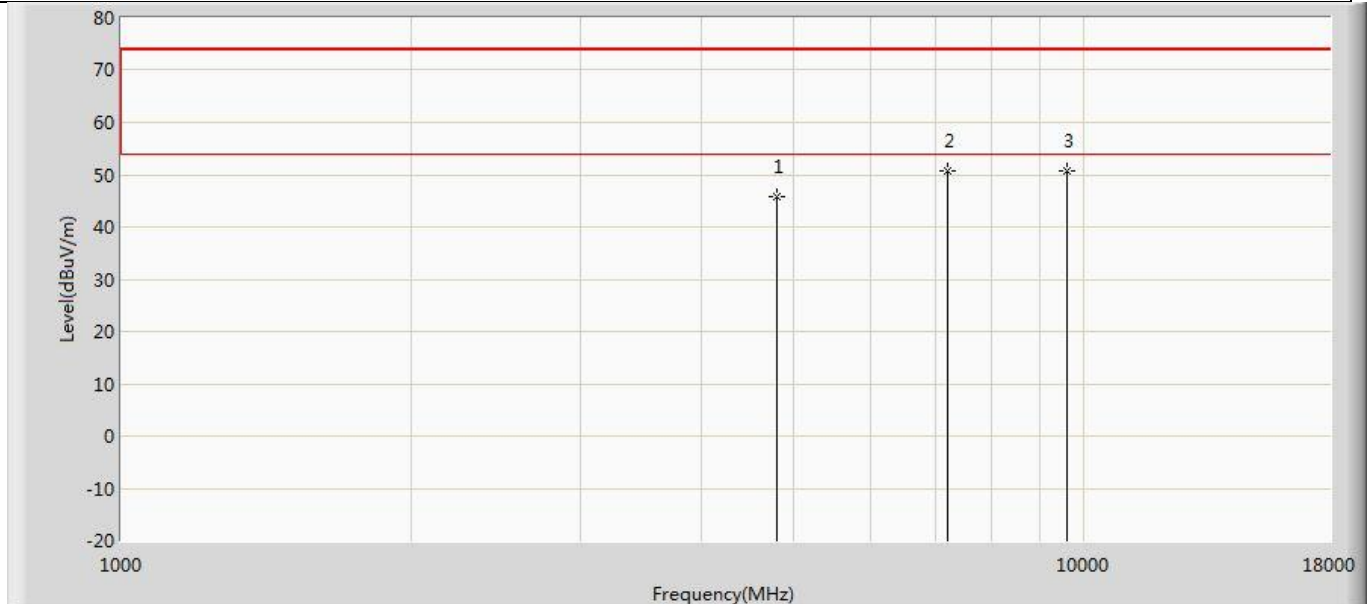

No	Mark	Frequency (MHz)	Measure Level (dBuV/m)	Reading Level (dBuV)	Over Limit (dB)	Limit (dBuV/m)	Factor (dB)	Type
1		4804.000	45.781	51.923	-28.219	74.000	-6.143	PK
2	*	7205.000	50.646	52.952	-23.354	74.000	-2.306	PK
3		9608.000	50.581	48.130	-23.419	74.000	2.451	PK

Profile: 2210113R	Page No.: 135
Engineer: Juliuszhou	
Site: AC5	Time: 2022/01/19 - 14:03
Limit: FCC_Part15.209_RE(3m)	Margin: 0
Probe: Horn_3117_00123988_(1-18GHz)	Polarity: Horizontal
EUT: BLUETOOTH HEADSET	Power: AC 120V/60Hz
Note: Mode 3:Transmit at 2441MHz by 3DH5	

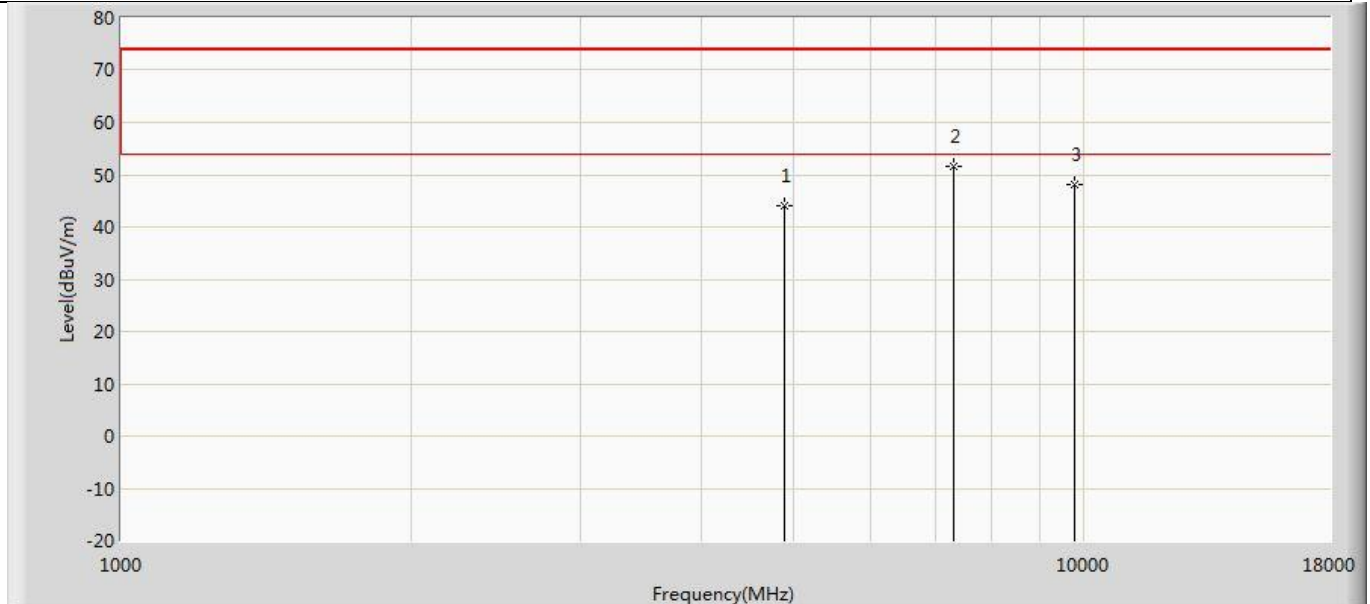

No	Mark	Frequency (MHz)	Measure Level (dBuV/m)	Reading Level (dBuV)	Over Limit (dB)	Limit (dBuV/m)	Factor (dB)	Type
1		4882.000	44.075	49.854	-29.925	74.000	-5.779	PK
2	*	7324.000	51.520	53.813	-22.480	74.000	-2.293	PK
3		9764.000	48.056	46.827	-25.944	74.000	1.229	PK

Profile: 2210113R	Page No.: 136
Engineer: Juliuszhou	
Site: AC5	Time: 2022/01/19 - 14:03
Limit: FCC_Part15.209_RE(3m)	Margin: 0
Probe: Horn_3117_00123988_(1-18GHz)	Polarity: Vertical
EUT: BLUETOOTH HEADSET	Power: AC 120V/60Hz
Note: Mode 3:Transmit at 2441MHz by 3DH5	

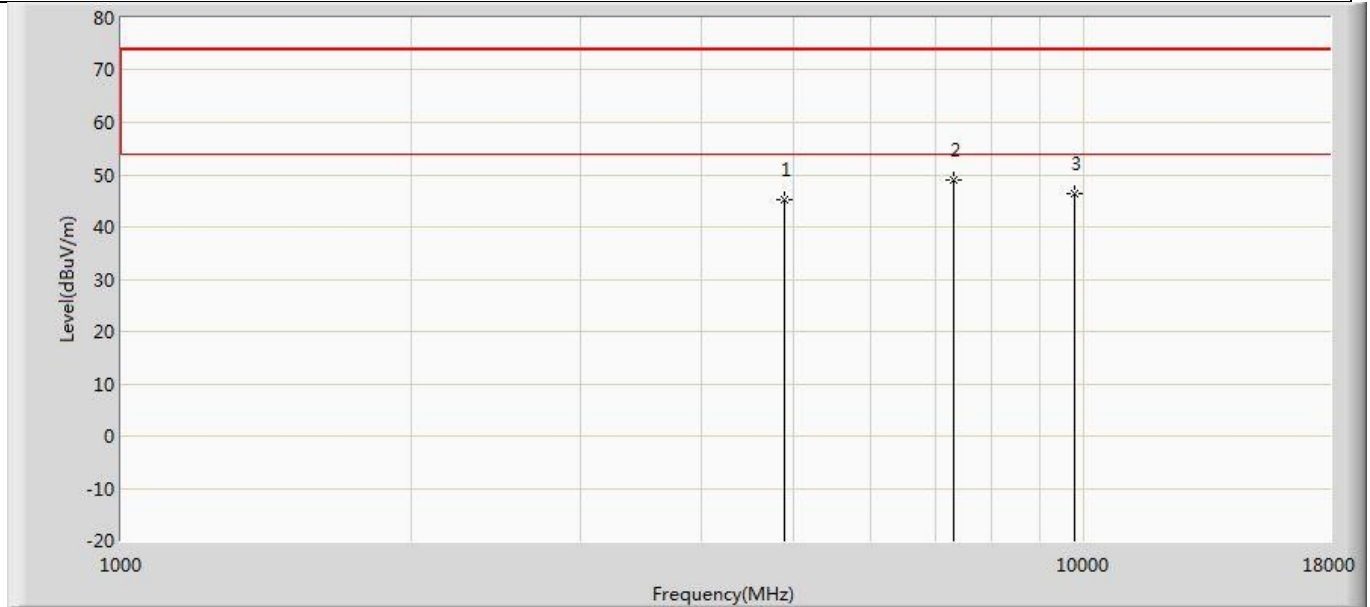

No	Mark	Frequency (MHz)	Measure Level (dBuV/m)	Reading Level (dBuV)	Over Limit (dB)	Limit (dBuV/m)	Factor (dB)	Type
1		4882.000	45.235	51.014	-28.765	74.000	-5.779	PK
2	*	7324.000	48.921	51.214	-25.079	74.000	-2.293	PK
3		9764.000	46.510	45.281	-27.490	74.000	1.229	PK

Profile: 2210113R	Page No.: 137
Engineer: Juliuszhou	
Site: AC5	Time: 2022/01/19 - 14:03
Limit: FCC_Part15.209_RE(3m)	Margin: 0
Probe: Horn_3117_00123988_(1-18GHz)	Polarity: Horizontal
EUT: BLUETOOTH HEADSET	Power: AC 120V/60Hz
Note: Mode 3:Transmit at 2480MHz by 3DH5	

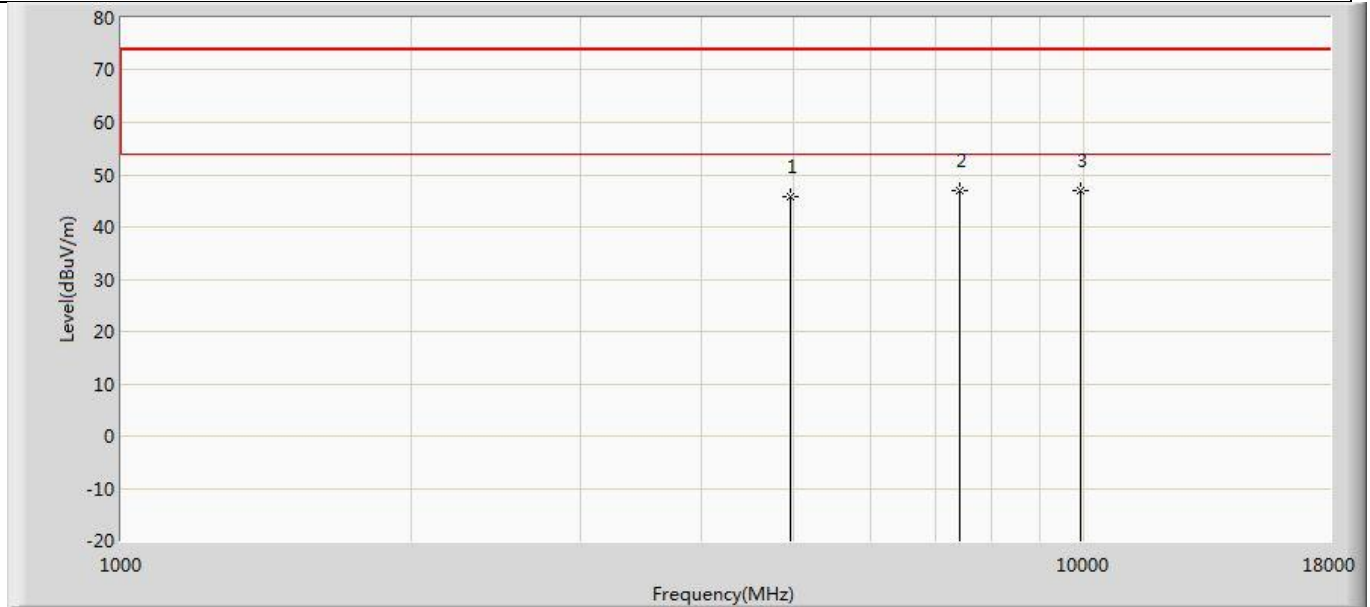

No	Mark	Frequency (MHz)	Measure Level (dBuV/m)	Reading Level (dBuV)	Over Limit (dB)	Limit (dBuV/m)	Factor (dB)	Type
1		4960.000	45.871	51.237	-28.129	74.000	-5.365	PK
2	*	7440.000	46.933	49.796	-27.067	74.000	-2.863	PK
3		9920.000	46.828	45.912	-27.172	74.000	0.916	PK

Profile: 2210113R	Page No.: 138
Engineer: Juliuszhou	
Site: AC5	Time: 2022/01/19 - 14:04
Limit: FCC_Part15.209_RE(3m)	Margin: 0
Probe: Horn_3117_00123988_(1-18GHz)	Polarity: Vertical
EUT: BLUETOOTH HEADSET	Power: AC 120V/60Hz
Note: Mode 3:Transmit at 2480MHz by 3DH5	

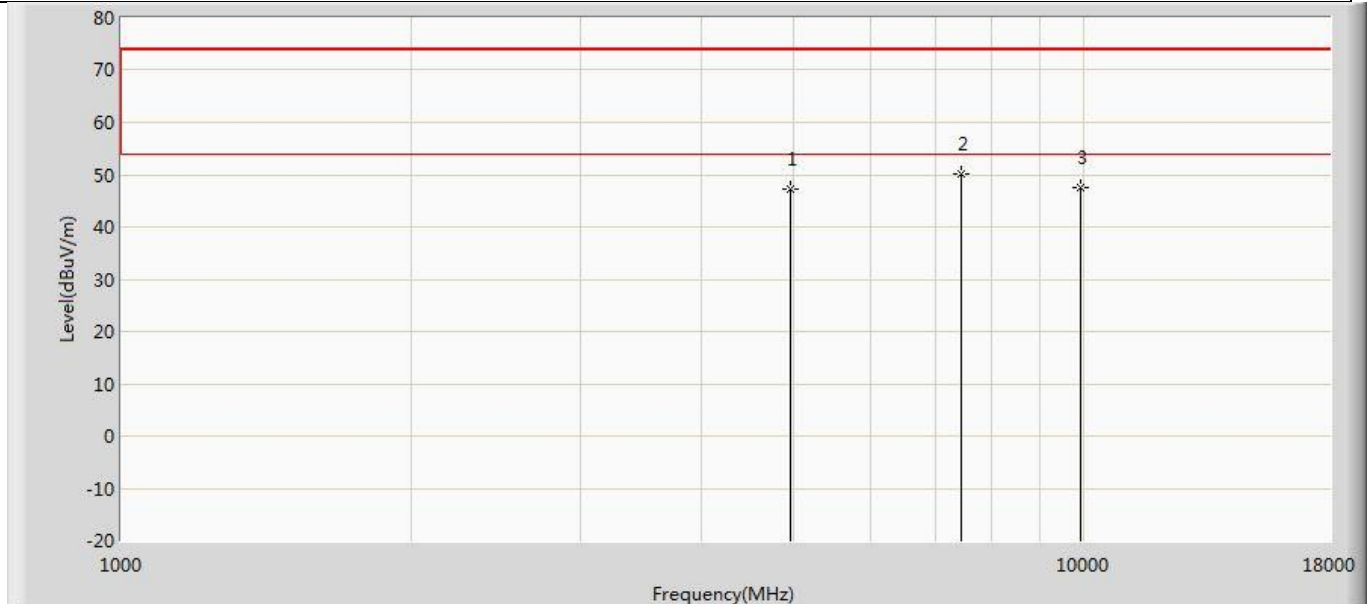

No	Mark	Frequency (MHz)	Measure Level (dBuV/m)	Reading Level (dBuV)	Over Limit (dB)	Limit (dBuV/m)	Factor (dB)	Type
1		4961.000	47.303	52.655	-26.697	74.000	-5.352	PK
2	*	7443.000	50.179	53.116	-23.821	74.000	-2.937	PK
3		9920.000	47.394	46.478	-26.606	74.000	0.916	PK

Note:

1. Measured Level = Reading Level + Factor.
2. The test frequency range, 9kHz~30MHz, worst case are at least 20dB below the limits, therefore no data appear in the report.
3. The test frequency range, 18GHz~26GHz test result on peak is lower than average limit, all is the noise base, therefore no data appear in the report.
4. This limit applies for using average detector, if the test result on peak is lower than average limit, then average measurement needn't be performed.
5. As the radiated emission was performed, so conducted emission was not tested.

The worst case of Radiated Emission below 1GHz:

Profile: 2210113R	Page No.: 37
Engineer: Carlos shen	
Site: AC2	Time: 2022/01/19 - 04:02
Limit: FCC_Part15.209_RE(3m)	Margin: 0
Probe: AC2_3M(30-1000M)	Polarity: Horizontal
EUT: Bluetooth headset	Power: AC 120V/60Hz
Note: Mode1: Transmit at 2402MHz by DH5	

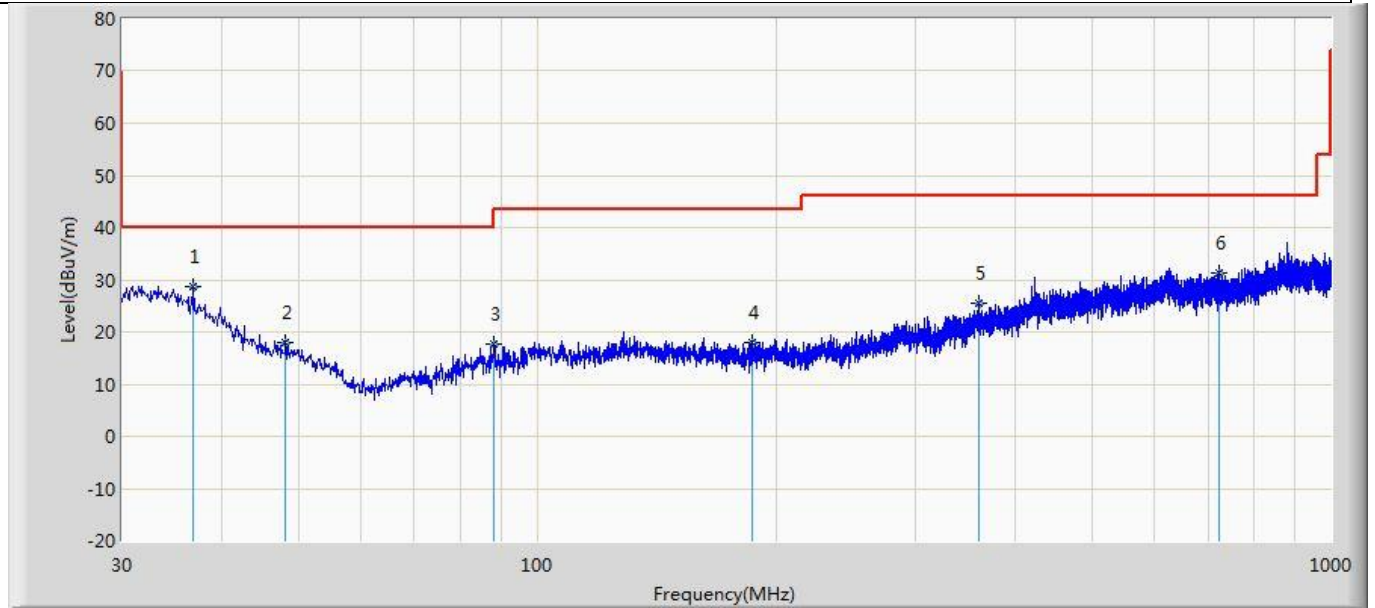

No	Mark	Frequency (MHz)	Measure Level (dBuV/m)	Reading Level (dBuV)	Over Limit (dB)	Limit (dBuV/m)	Factor (dB)	Type
1	*	36.911	28.654	3.477	-11.346	40.000	25.176	QP
2		48.187	18.095	1.900	-21.905	40.000	16.195	QP
3		88.200	17.610	3.777	-25.890	43.500	13.833	QP
4		186.655	18.104	1.091	-25.396	43.500	17.013	QP
5		360.649	25.578	1.298	-20.422	46.000	24.280	QP
6		723.186	31.441	2.026	-14.559	46.000	29.416	QP

Note:

1. All Readings below 1GHz are Quasi-Peak, above are performed with peak and/or average measurements as necessary.
2. " * ", means this data is the worst emission level.
3. Measurement Level = Reading Level + Factor(Probe+Cable-Amp)

Profile: 2210113R	Page No.: 38
Engineer: Carlos shen	
Site: AC2	Time: 2022/01/19 - 04:03
Limit: FCC_Part15.209_RE(3m)	Margin: 0
Probe: AC2_3M(30-1000M)	Polarity: Vertical
EUT: Bluetooth headset	Power: AC 120V/60Hz
Note: Mode1: Transmit at 2402MHz by DH5	

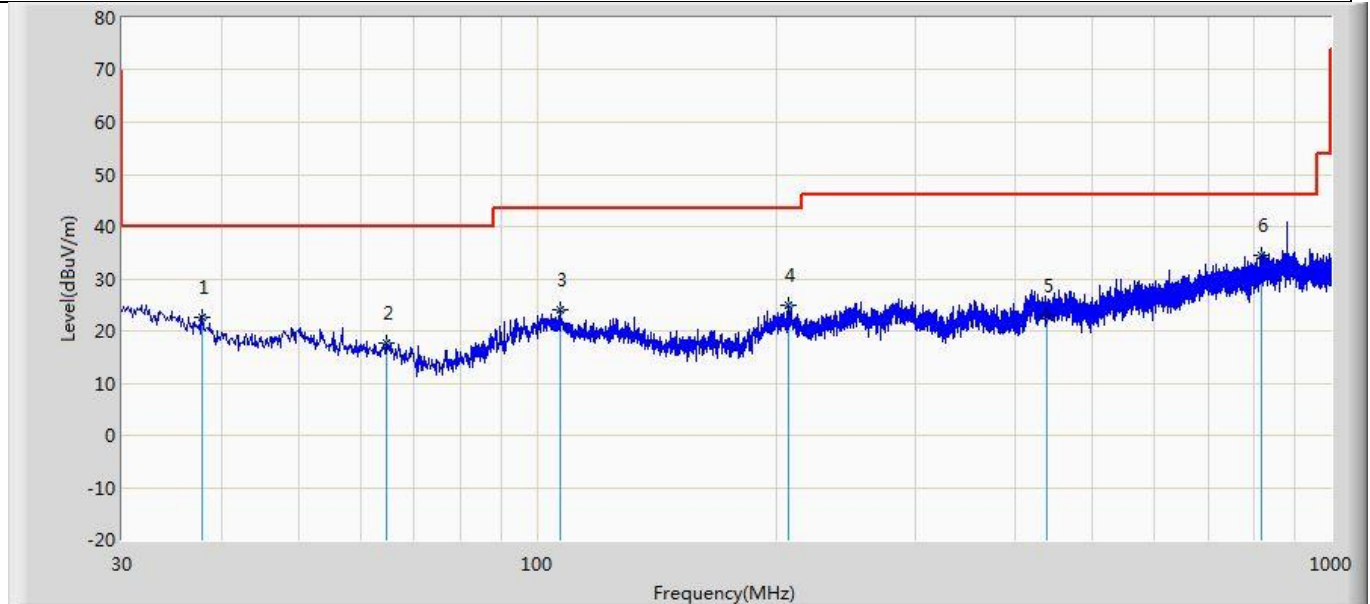

No	Mark	Frequency (MHz)	Measure Level (dBuV/m)	Reading Level (dBuV)	Over Limit (dB)	Limit (dBuV/m)	Factor (dB)	Type
1		37.881	22.714	2.226	-17.286	40.000	20.488	QP
2		64.677	17.701	1.782	-22.299	40.000	15.919	QP
3		106.872	23.958	2.180	-19.542	43.500	21.778	QP
4		207.268	24.798	1.461	-18.702	43.500	23.337	QP
5		437.885	22.908	-3.209	-23.092	46.000	26.117	QP
6	*	815.943	34.541	1.696	-11.459	46.000	32.845	QP

Note:

1. All Readings below 1GHz are Quasi-Peak, above are performed with peak and/or average measurements as necessary.
2. " * ", means this data is the worst emission level.
3. Measurement Level = Reading Level + Factor(Probe+Cable-Amp)

4.3 20dB Bandwidth	VERDICT: PASS
---------------------------	----------------------

4.3.1 Limit

Standard	FCC Part 15 Subpart C Paragraph 15.247(a)
<input checked="" type="checkbox"/>	For frequency hopping systems operating in 2400-2483.5 MHz band, within frequency range.
<input type="checkbox"/>	For frequency hopping systems operating in 902-928 MHz band, the maximum allowed 20 dB bandwidth of the hopping channel is 500 kHz.
<input type="checkbox"/>	For frequency hopping systems operating in 5725-5850 MHz band, the maximum 20 dB bandwidth of the hopping channel is 1 MHz.

4.3.2 Test Setup

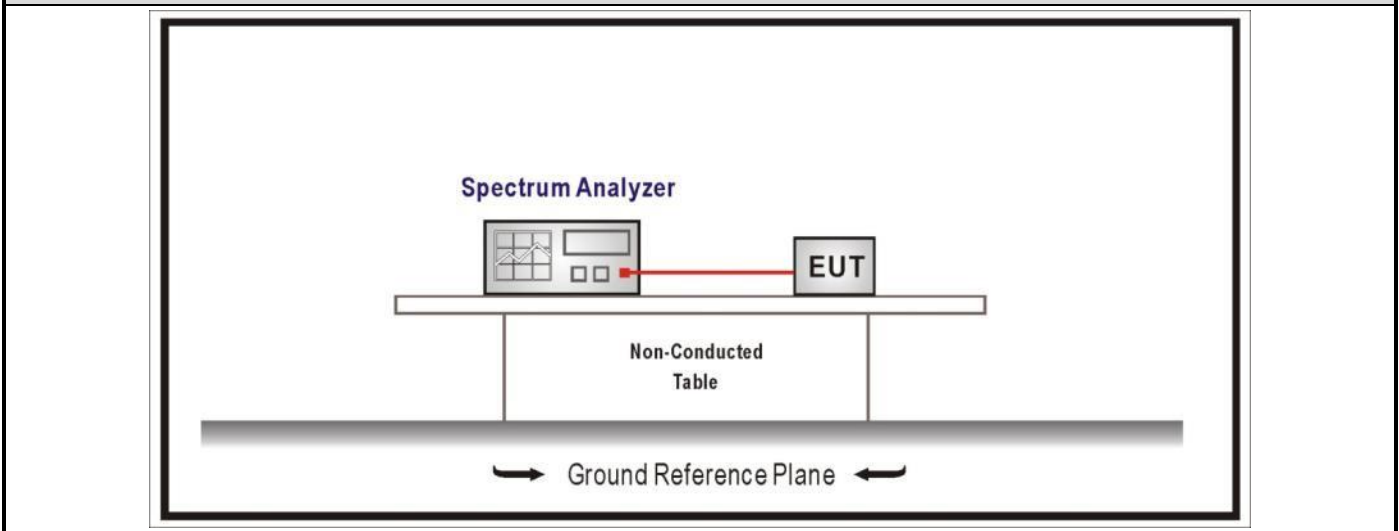

4.3.3 Test Procedure

	References Rule	Chapter	Description
<input checked="" type="checkbox"/>	ANSI C63.10	6.9	Occupied bandwidth tests
<input checked="" type="checkbox"/>	ANSI C63.10	6.9.2	Occupied bandwidth—relative measurement procedure

4.3.4 Test Data

Mode	Channel	Frequency (MHz)	20dB Bandwidth (kHz)	99% Bandwidth (kHz)
1	00	2402	923.4	873.02
	39	2441	923.0	871.64
	79	2480	921.4	868.50
2	00	2402	1335	1204.8
	39	2441	1333	1202.5
	79	2480	1320	1201.2
3	00	2402	1234	1131.1
	39	2441	1239	1135.6
	79	2480	1208	1138.1

Note 1: The worst data plot as below:

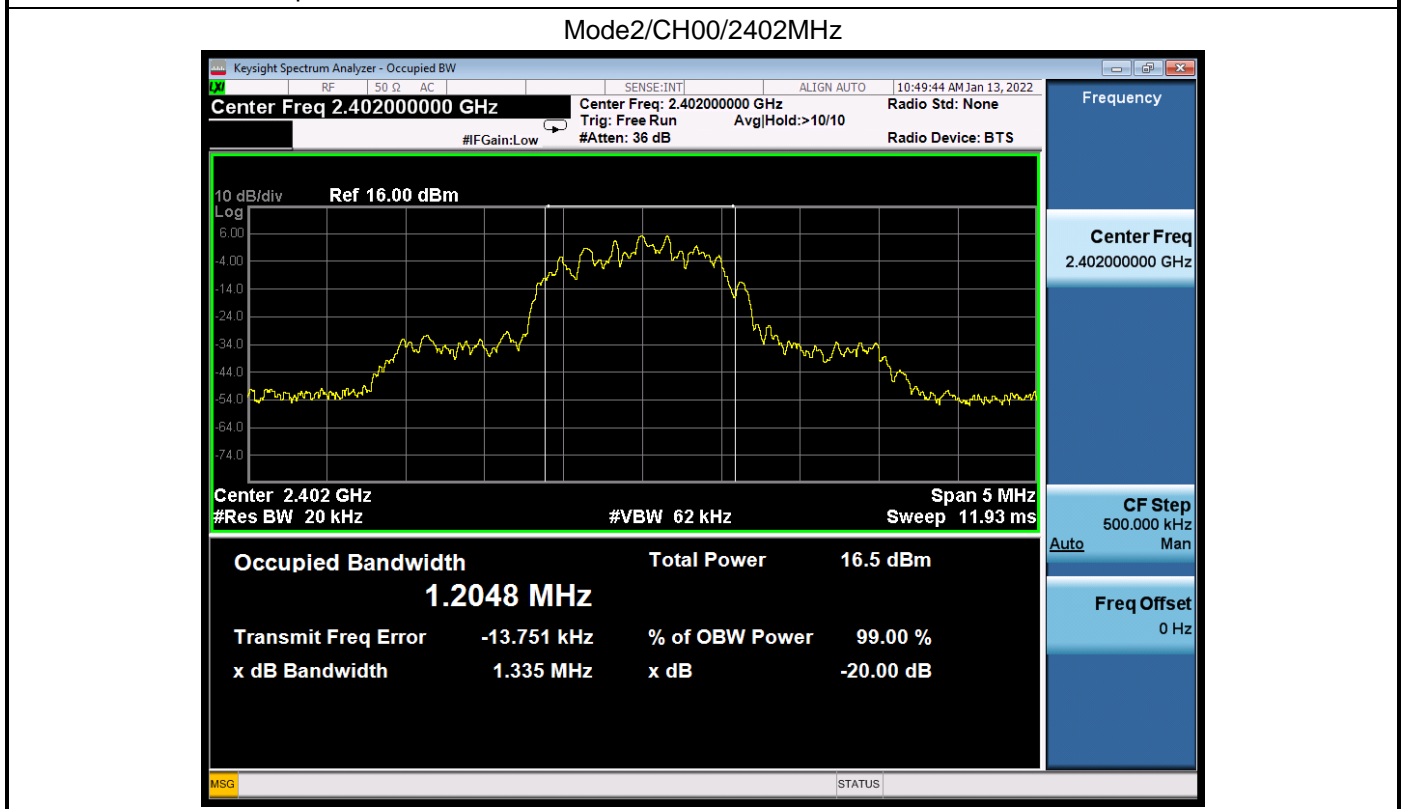

4.4 CarrierFrequencySeparation	VERDICT: PASS
---------------------------------------	----------------------

4.4.1 Limit

Standard	FCC Part 15 Subpart C Paragraph 15.247(a)
<input type="checkbox"/>	Frequency hopping systems shall have hopping channel carrier frequencies separated by a minimum of 25 kHz or the 20 dB bandwidth of the hopping channel, whichever is greater.
<input checked="" type="checkbox"/>	Frequency hopping systems operating in the 2400-2483.5 MHz band may have hopping channel carrier frequencies that are separated by 25 kHz or two-thirds of the 20 dB bandwidth of the hopping channel.
<input type="checkbox"/>	The 20 dB bandwidth of the hopping channel is less than 250 kHz, the system shall use at least 50 hopping frequencies and the average time of occupancy on any frequency shall not be greater than 0.4
<input type="checkbox"/>	The 20 dB bandwidth of the hopping channel is 250 kHz or greater, the system shall use at least 25 hopping frequencies and the average time of occupancy on any frequency shall not be greater than 0.4
<input type="checkbox"/>	Frequency hopping systems operating in the 5725-5850 MHz band shall use at least 75 hopping frequencies. The maximum 20 dB bandwidth of the hopping channel is 1 MHz.

4.4.2 Test Setup

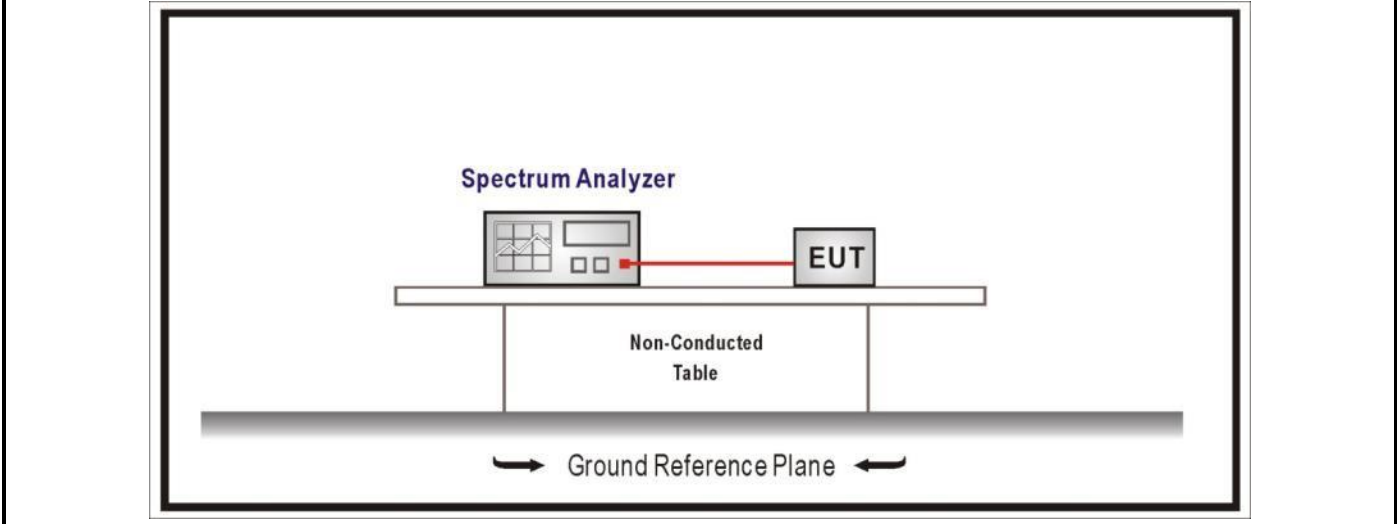

4.4.3 Test Procedure

References Rule	Chapter	Description
<input checked="" type="checkbox"/> ANSI C63.10	7.8	Evaluation of frequency-hopping device parameters
<input checked="" type="checkbox"/> ANSI C63.10	7.8.2	Carrier frequency separation

4.4.4 Test Data

Mode	Channel	Frequency (MHz)	Carrier Frequency Separation (kHz)	Limit (kHz)	Result
1	00	2402	1000	873.02	Pass
	39	2441	1000	871.64	Pass
	78	2480	1000	868.50	Pass
2	00	2402	1000	803.20	Pass
	39	2441	1000	801.67	Pass
	78	2480	1000	800.80	Pass
3	00	2402	1000	754.07	Pass
	39	2441	1000	757.07	Pass
	78	2480	1000	758.73	Pass

Note 1: The worst data plot as below:

Mode1/CH00/2402MHz

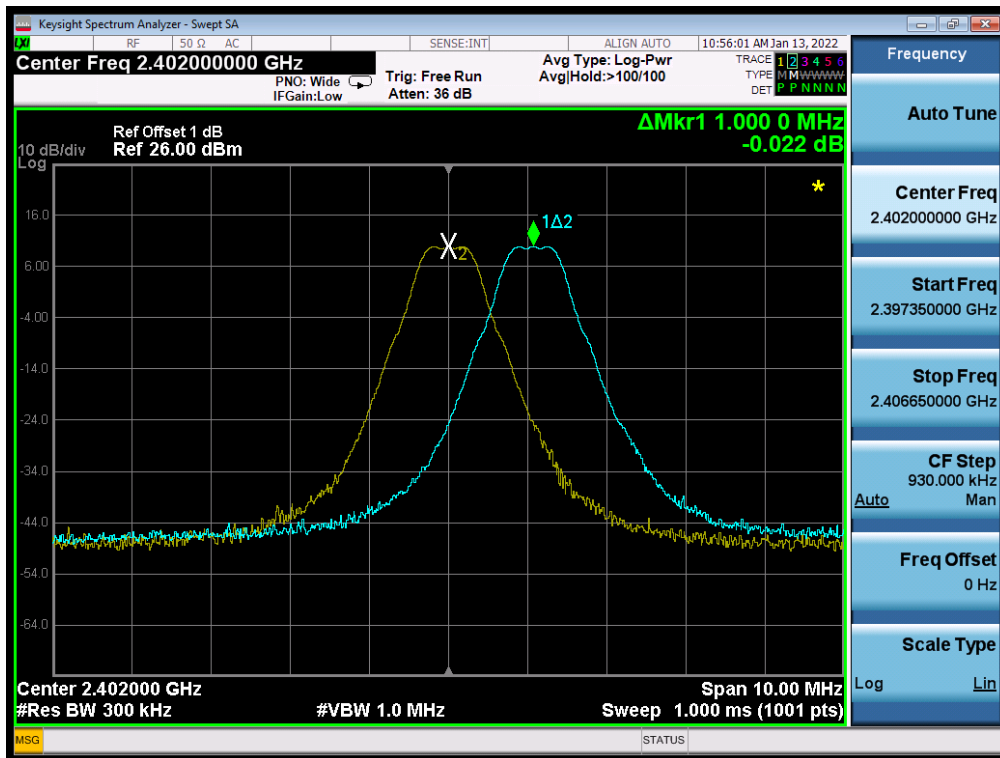

4.5 Number of hopping Frequencies	VERDICT: PASS
--	----------------------

4.5.1 Limit

Standard	FCC Part 15 Subpart C Paragraph 15.247(a)
<input checked="" type="checkbox"/>	For frequency hopping systems operating in the 2400-2483.5 MHz band shall use at least 15 hopping frequencies.
<input type="checkbox"/>	For frequency hopping systems operating in 902-928 MHz band, if the 20 dB bandwidth of the hopping channel is less than 250 kHz, shall use at least 50 hopping frequencies.
<input type="checkbox"/>	For frequency hopping systems operating in 902-928 MHz band, if the 20 dB bandwidth of the hopping channel is higher than 250 kHz, shall use at least 25 hopping frequencies.
<input type="checkbox"/>	For frequency hopping systems operating in the 5725-5850 MHz band shall use at least 75 hopping frequencies.

4.5.2 Test Setup

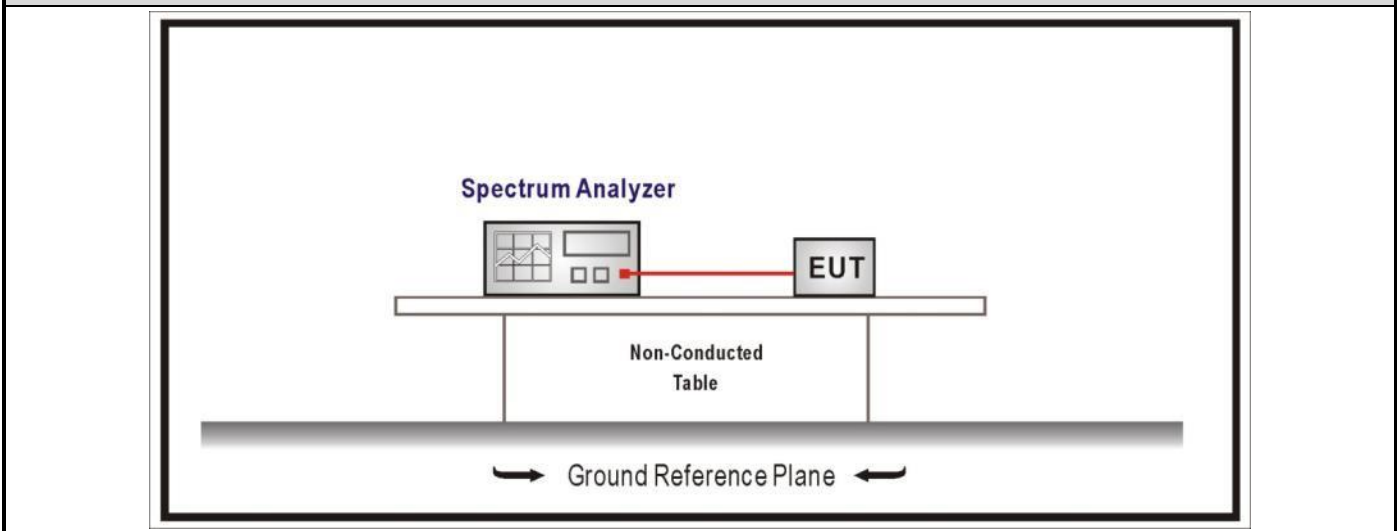

4.5.3 Test Procedure

	References Rule	Chapter	Description
<input checked="" type="checkbox"/>	ANSI C63.10	7.8.	Evaluation of frequency-hopping device parameters
<input checked="" type="checkbox"/>	ANSI C63.10	7.8.3	Number of Hopping Frequencies

4.5.4 Test Data

Mode	Number of Hopping Frequencies	Limit	Result
1	79	>15	Pass
2	79	>15	Pass
3	79	>15	Pass

Mode 1

Mode2

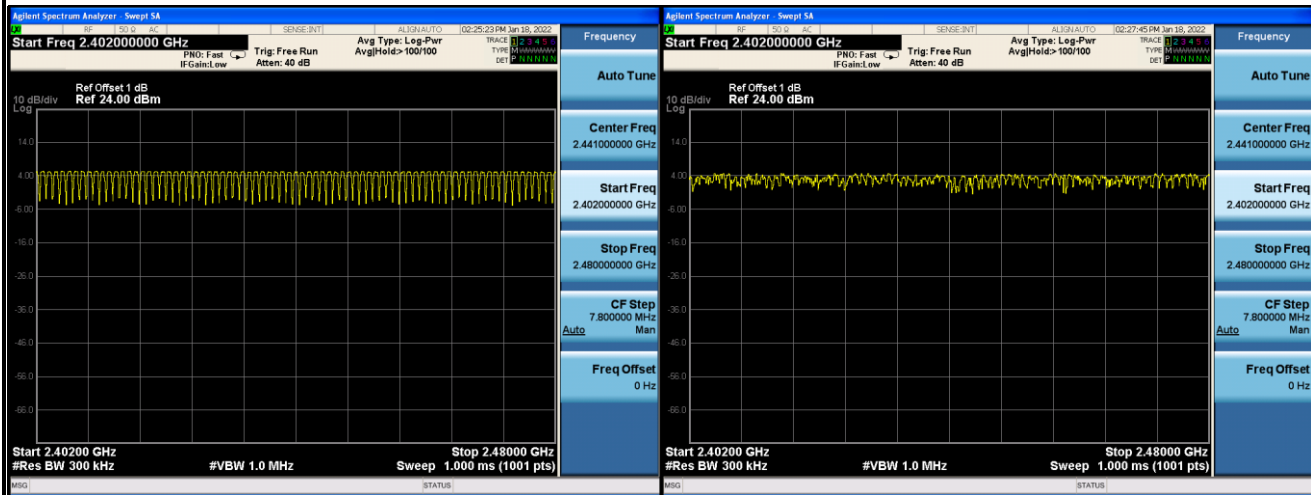

Mode 3

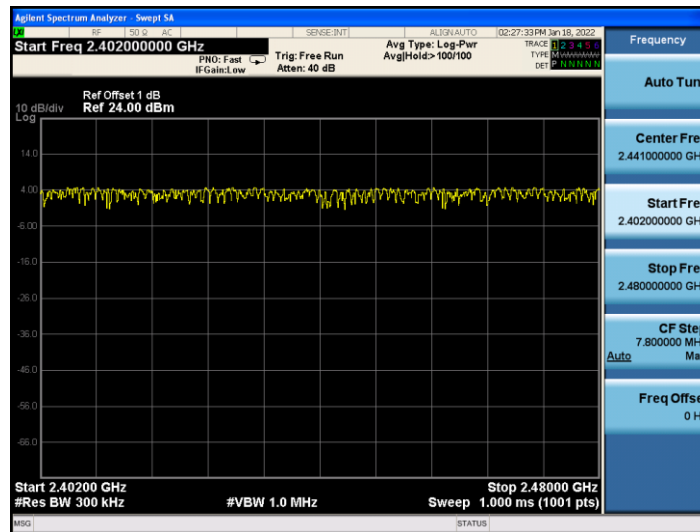

4.6 Time of Occupancy(Dwell Time)	VERDICT: PASS
--	----------------------

4.6.1 Limit

Standard	FCC Part 15 Subpart C Paragraph 15.247(a)
<input checked="" type="checkbox"/>	Frequency hopping systems in the 2400-2483.5 MHz band shall use at least 15 channels. The average time of occupancy on any channel shall not be greater than 0.4 seconds within a period of 0.4 seconds multiplied by the number of hopping channels employed.
<input type="checkbox"/>	For frequency hopping systems operating in the 902-928 MHz band: if the 20 dB bandwidth of the hopping channel is less than 250 kHz, the system shall use at least 50 hopping frequencies and the average time of occupancy on any frequency shall not be greater than 0.4 seconds within a 20 second period
<input type="checkbox"/>	For frequency hopping systems operating in the 902-928 MHz band: if the 20 dB bandwidth of the hopping channel is 250 kHz or greater, the system shall use at least 25 hopping frequencies and the average time of occupancy on any frequency shall not be greater than 0.4 seconds within a 10 second period.
<input type="checkbox"/>	Frequency hopping systems operating in the 5725-5850 MHz band shall use at least 75 hopping frequencies. The maximum 20 dB bandwidth of the hopping channel is 1 MHz. The average time of occupancy on any frequency shall not be greater than 0.4 seconds within a 30 second period.

4.6.2 Test Setup

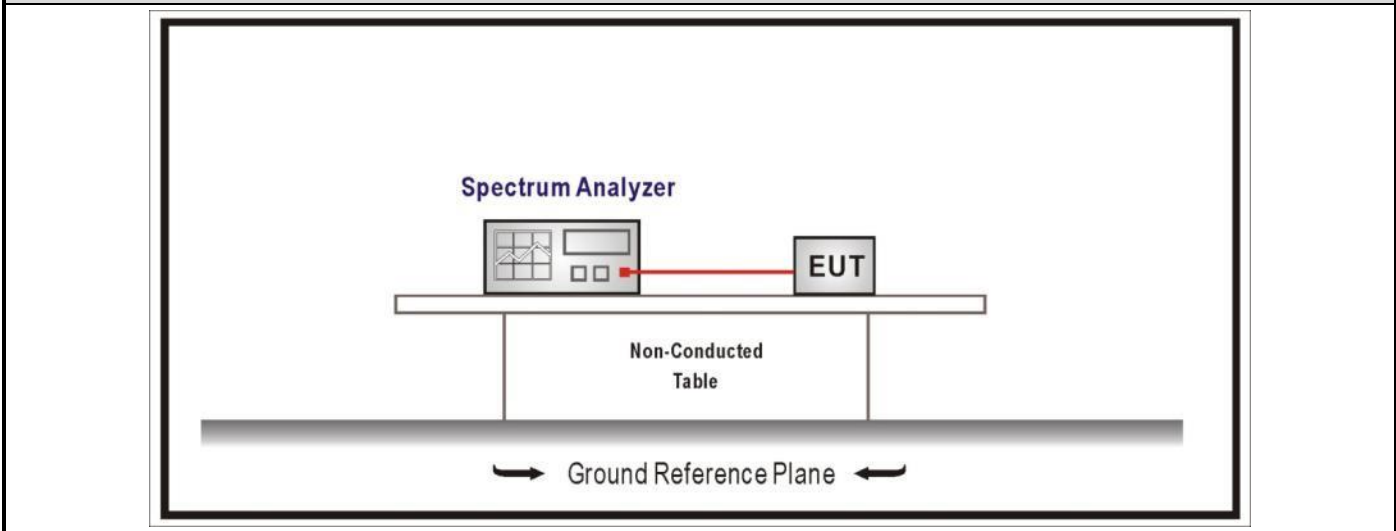

4.6.3 Test Procedure

	References Rule	Chapter	Description
<input checked="" type="checkbox"/>	ANSI C63.10	7.8	Evaluation of frequency-hopping device parameters
<input checked="" type="checkbox"/>	ANSI C63.10	7.8.4	Time of occupancy (dwell time)

4.6.4 Test Data

Mode	Channel	Frequency (MHz)	Time of Occupancy (ms)	Limit (ms)	Result
1	39	2441	118.08	< 400	Pass

Note1: Test Time Period: $0.4 \times 79 = 31.6 \text{sec}$

Note2: Time of Occupancy = $0.369 \times 32 \times 31.6 / 3.16 = 121.6 \text{ms}$

Note3: We have evaluated different packet type, shown in the report is the worst data.

Channel 39 (2441MHz) - (DH1)

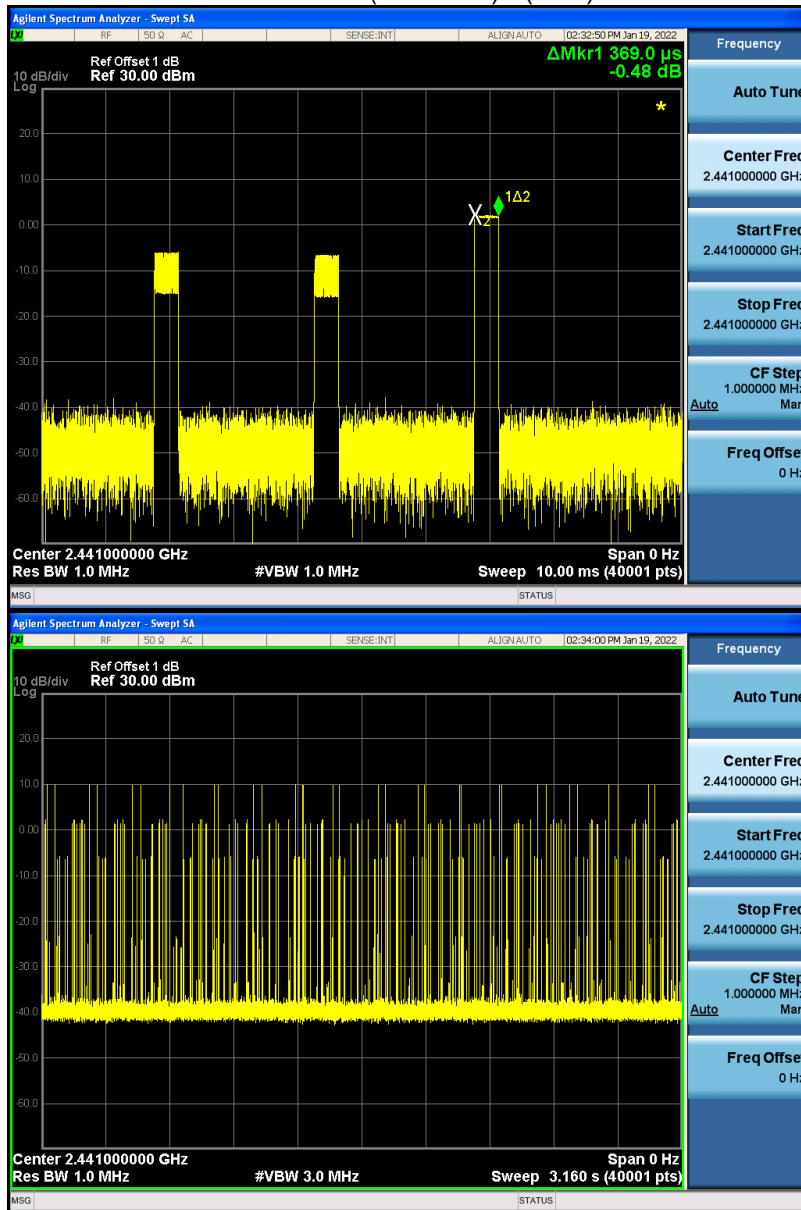

Mode	Channel	Frequency (MHz)	Time of Occupancy (ms)	Limit (ms)	Result
1	39	2441	228.34	< 400	Pass

Note1: Test Time Period: $0.4 * 79 = 31.6 \text{sec}$

Note2: Time of Occupancy = $1.631 * 14 * 31.6 / 3.16 = 245.1 \text{ms}$

Note3: We have evaluated different packet type, shown in the report is the worst data.

Channel 39 (2441MHz) - (DH3)

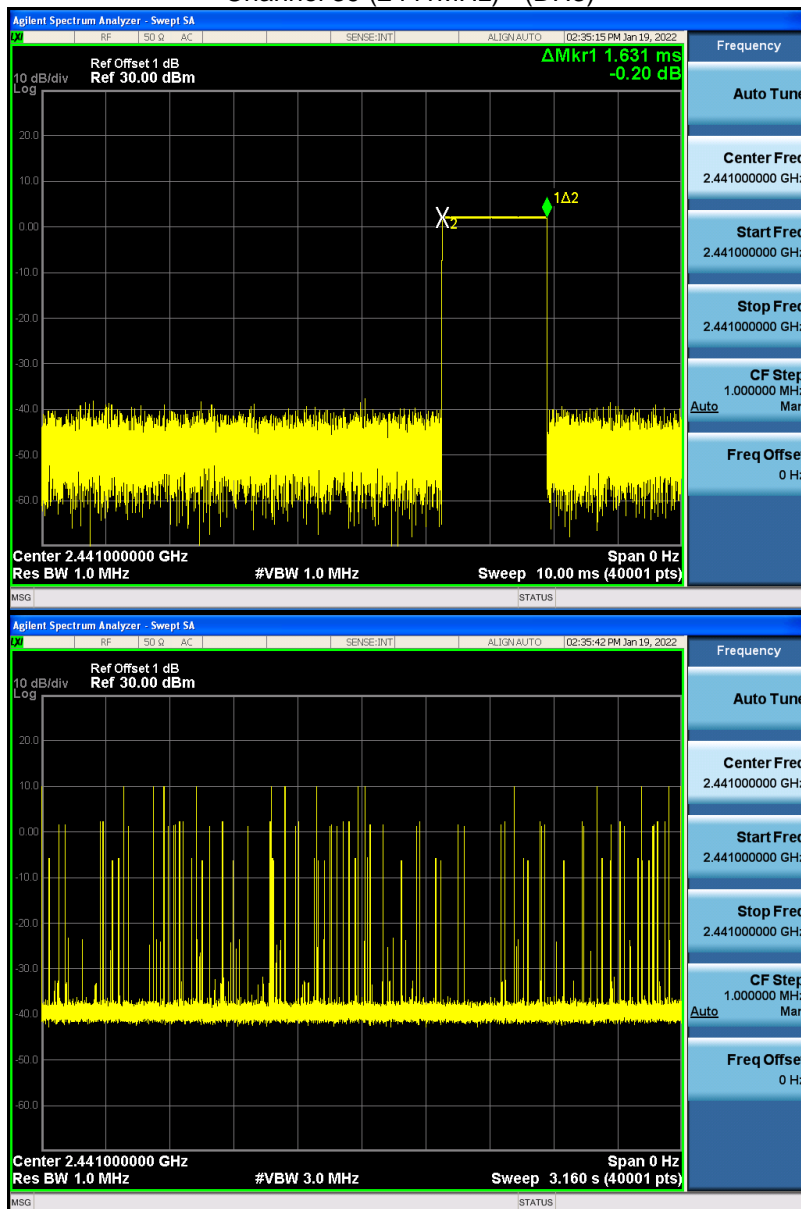

Mode	Channel	Frequency (MHz)	Time of Occupancy (ms)	Limit (ms)	Result
1	39	2441	315.92	< 400	Pass

Note1: Test Time Period: $0.4 \times 79 = 31.6 \text{sec}$

Note2: Time of Occupancy = $2.872 \times 11 \times 31.6 / 3.16 = 203.8 \text{ms}$

Note3: We have evaluated different packet type, shown in the report is the worst data.

Channel 39 (2441MHz) - (DH5)

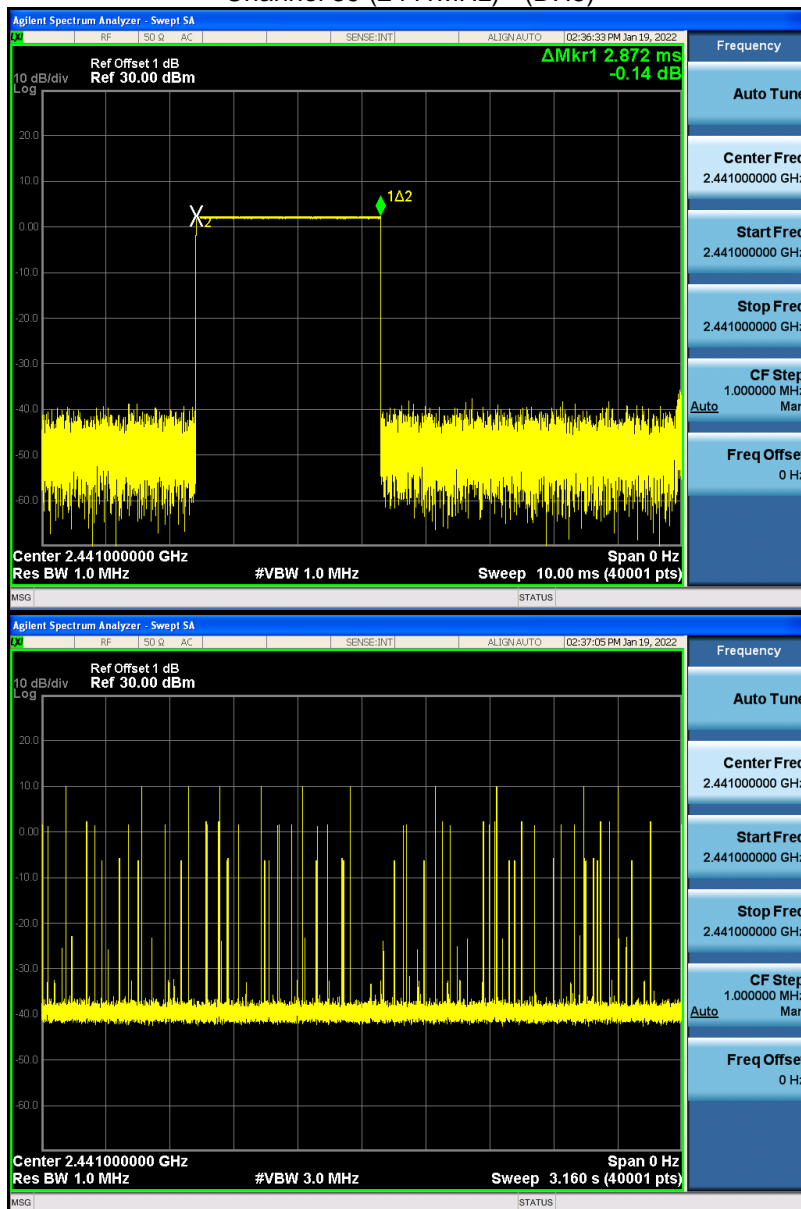

Note: The packet time of AFH mode is same as normal mode, due to the packet time of AFH mode multiply with lesser factor is dwell time of $0.4 \times 20 = 8 \text{S}$, the dwell time of AFH mode comply with the limit.

4.7 Peak Output Power	VERDICT: PASS
------------------------------	----------------------

4.7.1 Limit

Standard	FCC Part 15 Subpart C Paragraph 15.247 (a)(1)
<input checked="" type="checkbox"/>	Frequency hopping systems operating in the 2400-2483.5 MHz band employing at least 75 non-overlapping hopping channels, and all frequency hopping systems in the 5725-5850 MHz band: 1 watt. For all other frequency hopping systems in the 2400-2483.5 MHz band: 0.125 watts.
<input checked="" type="checkbox"/>	Frequency hopping systems operating in the 2400-2483.5 MHz band may have hopping channel carrier frequencies that are separated by 25 kHz or two-thirds of the 20 dB bandwidth of the hopping channel, whichever is greater, provided the systems operate with an output power no greater than 125 mW.
<input type="checkbox"/>	For frequency hopping systems operating in the 902-928 MHz band: 1 watt for systems employing at least 50 hopping channels; and, 0.25 watts for systems employing less than 50 hopping channels, but at least 25 hopping channels

4.7.2 Test Setup

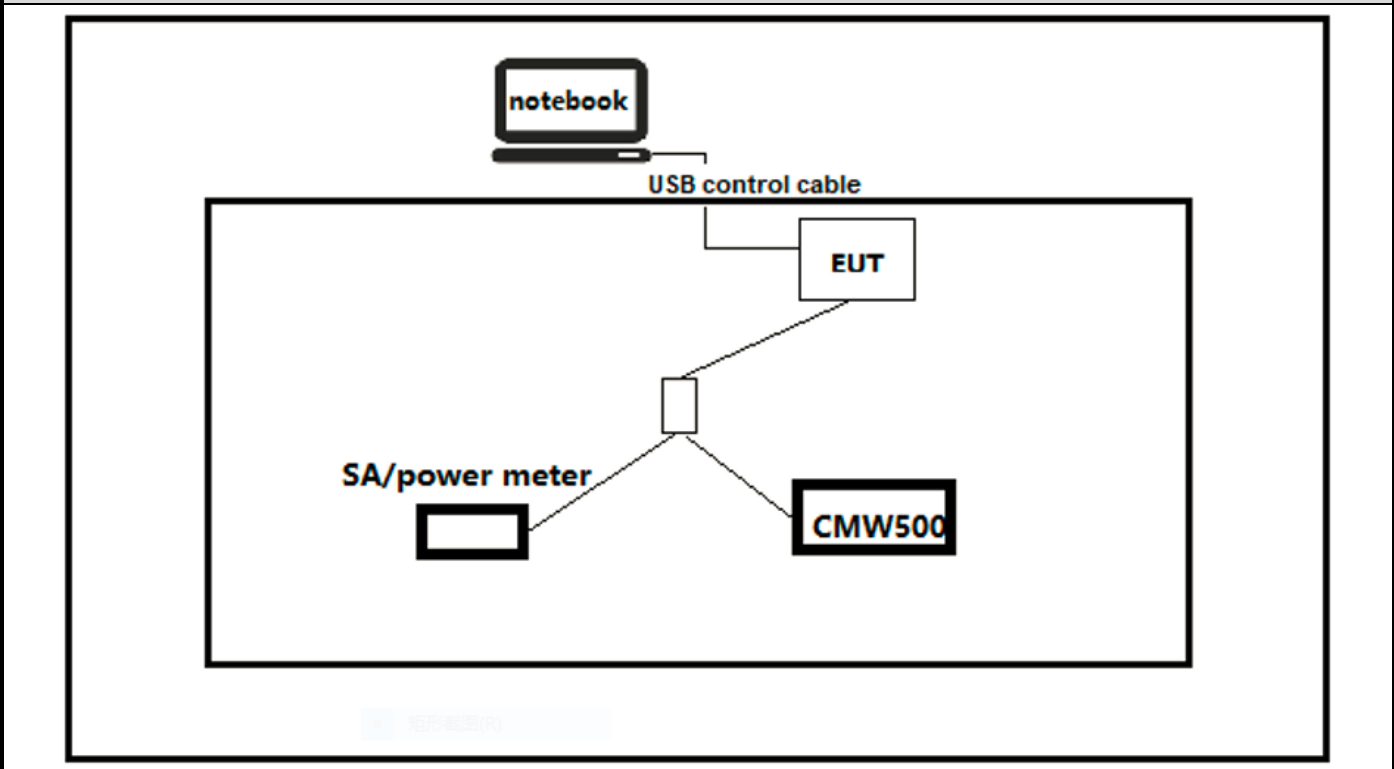

Note: Use BlueTest3 to make EUT enter DUT mode, connect CMW500 and power meter through power divider, put CMW500 in Max Output mode, make the earphone output maximum RF power, and measure the power value through power meter.

4.7.3 Test Procedure				
	References Rule		Chapter	Description
<input checked="" type="checkbox"/>	ANSI C63.10		7.8	Evaluation of frequency-hopping device parameters
	<input checked="" type="checkbox"/>	ANSI C63.10	7.8.5	<p>Output power test procedure for frequency-hopping spread-spectrum (FHSS) devices:</p> <p>This is an RF-conducted test to evaluate maximum peak output power. Use a direct connection between the antenna port of the unlicensed wireless device and the spectrum analyzer, through suitable attenuation. The hopping shall be disabled for this test:</p> <p>a) Use the following spectrum analyzer settings:</p> <ol style="list-style-type: none"> 1) Span: Approximately five times the 20 dB bandwidth, centered on a hopping channel. 2) RBW > 20 dB bandwidth of the emission being measured. 3) VBW ≥ RBW. 4) Sweep: Auto. 5) Detector function: Peak. 6) Trace: Max hold. <p>b) Allow trace to stabilize.</p> <p>c) Use the marker-to-peak function to set the marker to the peak of the emission.</p> <p>d) The indicated level is the peak output power, after any corrections for external attenuators and cables.</p> <p>e) A plot of the test results and setup description shall be included in the test report.</p> <p>NOTE—A peak responding power meter may be used, where the power meter and sensor system video bandwidth is greater than the occupied bandwidth of the unlicensed wireless device, rather than a spectrum analyzer.</p>

4.7.4 Test Data

Mode	Channel	Test Frequency (MHz)	Conducted Power (dBm)	Conducted Power Limit (dBm)	EIRP (dBm)	EIRP Limit (dBm)	Result
Mode 1	00	2402	11.17	≤30	14.76	≤36	Pass
	39	2441	11.11	≤30	14.70	≤36	Pass
	78	2480	10.95	≤30	14.54	≤36	Pass
Mode 2	00	2402	11.12	≤21	14.71	≤36	Pass
	39	2441	11.06	≤21	14.65	≤36	Pass
	78	2480	10.91	≤21	14.50	≤36	Pass
Mode 3	00	2402	11.07	≤21	14.66	≤36	Pass
	39	2441	11.01	≤21	14.60	≤36	Pass
	78	2480	10.83	≤21	14.42	≤36	Pass

4.8 Emissions in non-restricted frequency band	VERDICT: PASS
---	----------------------

4.8.1 Limit

Standard	FCC Part 15 Subpart C Paragraph 15.247(d)
RF Output power (Detection methods)	Limit(dB)
RF Output power(Average detector)	30dBc(Note1)
RF Output power(PK detector)	20dBc(Note2)

Note 1: If maximum conducted (average) output power was used to demonstrate compliance as described in 9.2, then the peak power in any 100 kHz bandwidth outside of the authorized frequency band shall be attenuated by at least 30 dB relative to the maximum in-band peak PSD level in 100 kHz (i.e., 30 dBc).

Note 2: If the maximum peak conducted output power procedure was used, then the peak output power measured in any 100 kHz bandwidth outside of the authorized frequency band shall be attenuated by at least 20 dB relative to the maximum in-band peak PSD level in 100 kHz (i.e., 20 dBc).

4.8.2 Test Setup

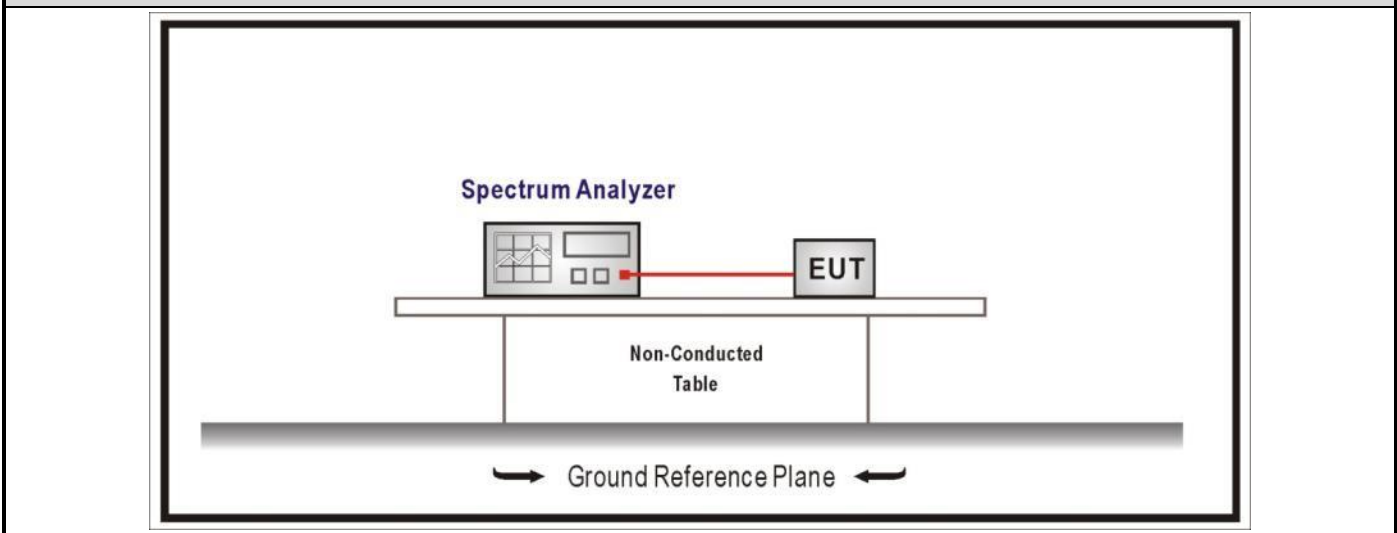

4.8.3 Test Procedure

References Rule	Chapter	Description
<input checked="" type="checkbox"/> ANSI C63.10	7.8	Evaluation of frequency-hopping device parameters
<input checked="" type="checkbox"/> ANSI C63.10	7.8.6	Band-edge measurements for RF conducted emissions

4.8.4 Test Data



