

# Voyager 4210/4220 Office Wireless Headset System for Desk Phone

DRAFT User Guide











# Contents

Overview	3
Headset overview	3
Base overview	4
Accessories	4
Hook up your system	5
Charge your headset	5
Pair to mobile device	6
Fit and charge	7
Wear on the right or left	7
Charge	7
Load software	8
System basics	9
How to	9
Adjust volume	9
Headset basics	10
Power on/off	10
Adjust the volume	10
Answer or end a call	10
Mute	10
Play or pause audio	10
Track selection	10
Fast forward/rewind	10
Voice assistant	10
Troubleshooting	11
Support	12

# Overview

## Headset overview



	LEDs
	Mute/unmute
Alexa	Voice assistant (*requires app)
	Power
	Bluetooth® pairing
	Charge
	Volume
	Call
Siri®, Google Assistant™	Default voice assistant: Siri®, Google Assistant™, Cortana
	Play/pause**
	Next track**
	Previous track**

**NOTE** \*\*Functionality varies by application. May not function with web-based apps.

### Be safe

Please read the safety guide for important safety, charging, battery and regulatory information before using your new headset.

## Base overview

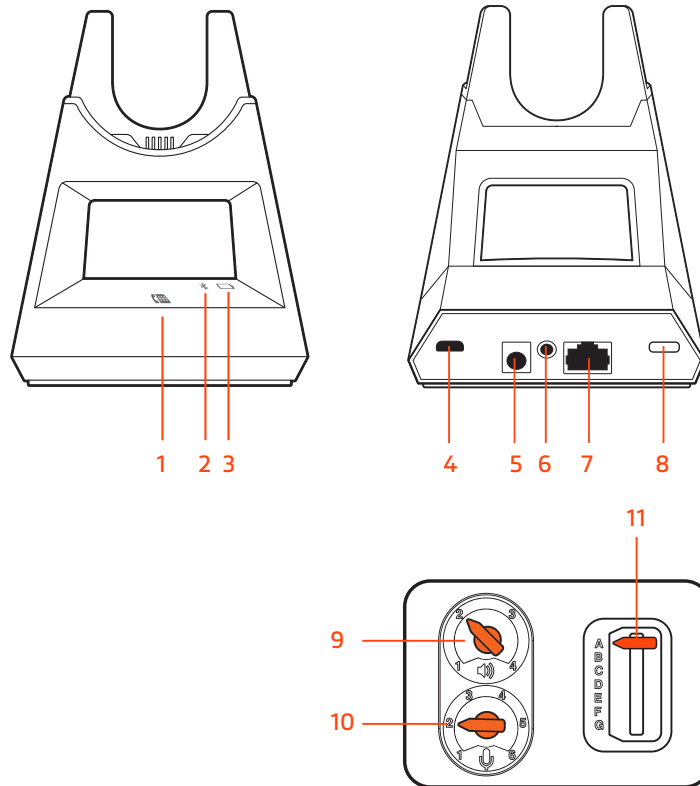

- 1 Desk phone button
- 2 Bluetooth LED
- 3 Charging LED
- 4 USB port
- 5 Power jack
- 6 Handset lifter jack

- 7 Telephone interface cable jack
- 8 Bluetooth pairing button
- 9 Desk phone listening volume
- 10 Desk phone speaking volume
- 11 Desk phone configuration switch

## Accessories

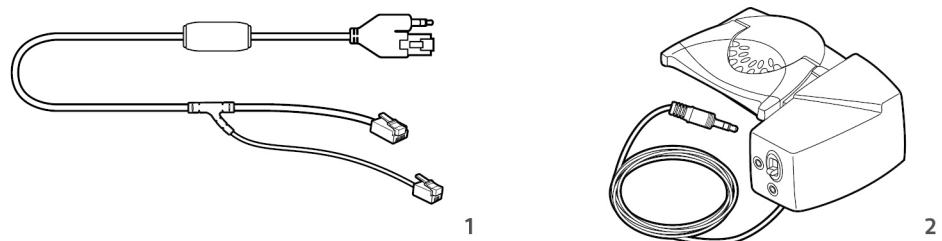

- 1 Electronic hookswitch cable (EHS cable)** Electronically and automatically answers/ends a desk phone call. Enables remote call control with your headset.
- 2 HL10 lifter** Automatically lifts handset and returns it to the cradle. Enables remote call control with your headset.

# Hook up your system

Using the diagram, connect your headset system.

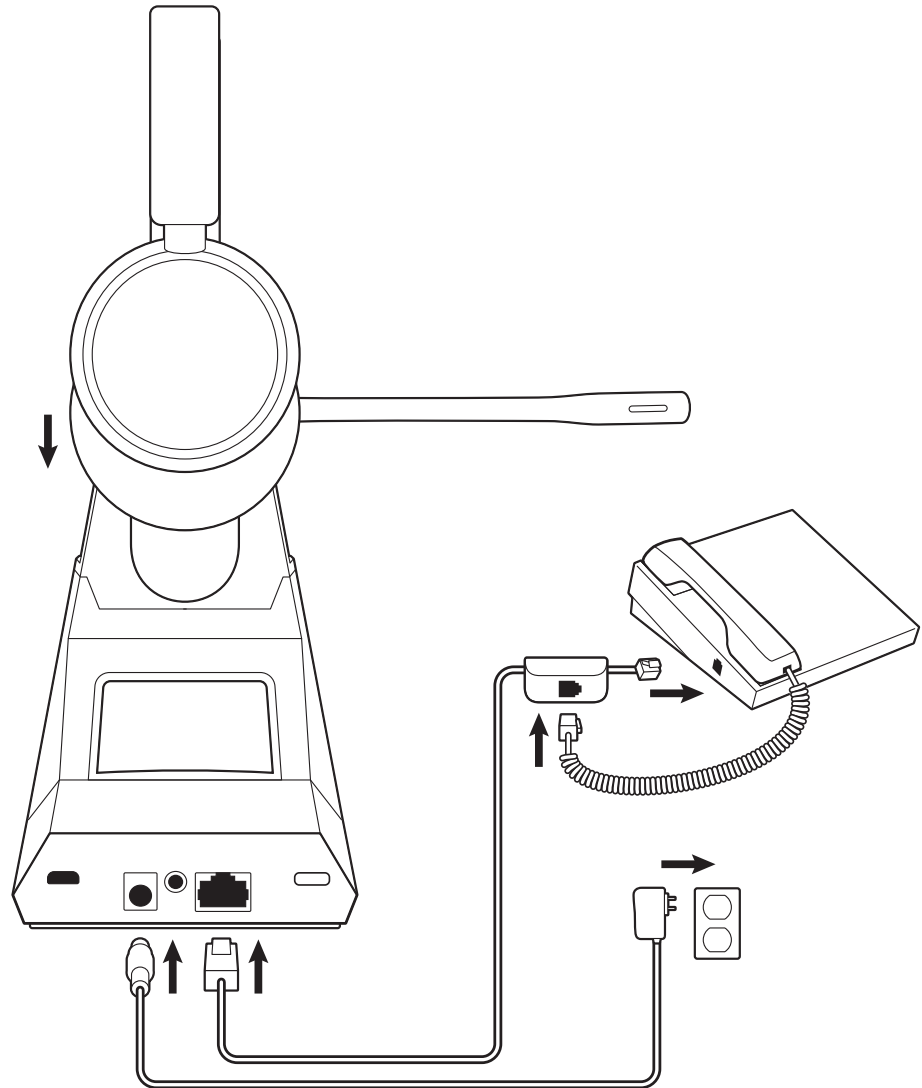

## Charge your headset

Charge your headset for a minimum of 20 minutes by placing it in the base. The cradle LED flashes blue when charging.

# Pair to mobile device

- 1 To put your headset in pair mode, slide and hold the Power  switch away from the off position until you hear "pairing" and the headset LEDs flash red and blue.

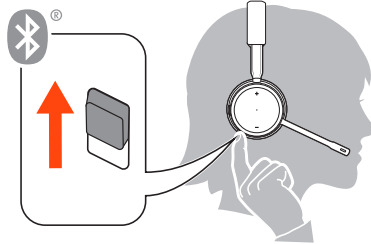

- 2 Select "PLT V4210 Series / PLT V4220 Series."  
If necessary, enter four zeros (0000) for the passcode or accept the connection.

Once successfully paired, you hear "pairing successful" and the headset LEDs stop flashing.

**NOTE** Your headset can pair with up to 8 devices but only maintain 2 connections simultaneously; this includes the Bluetooth USB adapter.

# Fit and charge

## Wear on the right or left

To position the microphone on the right or left side, rotate the microphone boom up and over. Gently bend the boom so it is approximately 2 finger widths from the corner of your mouth.

**IMPORTANT** For true stereo sound, wear the boom on your right side.

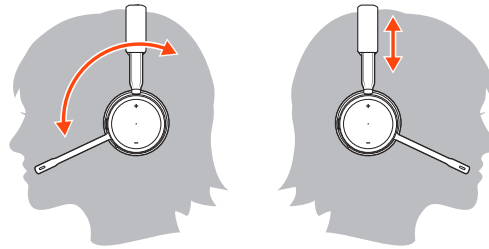

## Charge

It takes 90 minutes to fully charge the headset. The indicator light turns off once charging is complete.

# Load software

Plantronics Hub for Windows/Mac is an invaluable headset tool.

- 1 Download Plantronics Hub for Windows/Mac by visiting [plantronics.com/software](https://plantronics.com/software).
- 2 Using Plantronics Hub, manage your headset settings.
  - Call control for softphones
  - Change headset language
  - Update firmware
  - Turn features on/off



# System basics

## How to

### Make a call

- 1 Tap the Audio button  on the base.
- 2 Manually remove the handset if you don't have an HL10 lifter or EHS cable. You should hear a dial tone.  
**TIP** *If you do not hear a dial tone, turn over the base and adjust the switch (A--G). "A" works for the majority of desk phones.*
- 3 Dial from your desk phone.

### End/take a call

To answer or end a call, tap the Audio button  on the base or tap the headset call button.

## Adjust volume









- **Headset volume** Fine-tune your headset volume by adjusting the volume controls.
- **Desk phone volume** When you are on a desk phone call and your voice is too quiet/loud, adjust the microphone volume on the bottom of the base. If your caller's voice is too loud/quiet on a desk phone call, adjust the base volume dial.
- **Base ringtone volume** Adjust the base ringtone volume on the bottom of the base. This ringtone alerts you if you are not wearing your headset and a call comes in. There are 4 base ringer settings: off, low, medium and high.

### Adjust headset microphone volume (softphone)

Place a test softphone call and adjust softphone volume and PC sound volume accordingly.

# Headset basics



- Power on/off** Slide the switch  to power on or off.
- Adjust the volume** Tap the Volume up (+) or down (-) button.
- Answer or end a call** Tap the Call  button.
- Mute** While on an active call, tap the red Mute  button.
- Play or pause audio** Tap the Call  button.
- Track selection** Double-tap the Call  button to skip to the next track or triple-tap the Call  button to play the previous track.  
**NOTE** *Functionality varies by application. May not function with web-based apps.*
- Fast forward/rewind** Double-tap and hold the Call  button to fast-forward. Triple-tap and hold the Call  button to rewind.  
**NOTE** *Functionality varies by application. May not function with web-based apps.*
- Voice assistant** **Siri, Google Assistant™, Cortana** Press and hold the Call button for 2 seconds to activate your phone's default voice assistant. Wait for the phone prompt to activate voice dialing, search, and other smartphone voice controls.

# Troubleshooting

## **No dial tone in headset?**

- Ensure your headset is charged and paired to the base.
- Adjust the configuration switch on the bottom of your base until you hear a dial tone.
- Fine tune the headset listening volume.

## **Is headset sound distorted?**

- Ensure your headset mic is pointed toward the corner of your mouth.
- Fine tune the headset listening volume.

## **Need to pair your headset again?**

- Your headset comes pre-paired to the base. To pair again, put your headset into pair mode and press the Bluetooth pairing  button on the back of your base for 2 seconds until the LED flashes blue and red.



- Once successfully paired, the Bluetooth LED on the base turns solid blue.

# Support

## NEED MORE HELP?

[plantronics.com/support](https://plantronics.com/support)

**Plantronics, Inc.**

345 Encinal Street  
Santa Cruz, CA 95060  
United States

**Plantronics B.V.**

Scorpius 171  
2132 LR Hoofddorp  
Netherlands

© 2019 Plantronics, Inc. Bluetooth is a registered trademark of Bluetooth SIG, Inc. and any use by Plantronics, Inc. is under license. All other trademarks are the property of their respective owners.

xx-06 (05.19)