

FCC PART 15C TEST REPORT FOR CERTIFICATION
On Behalf of

Sony Group Corporation

Product: Sound Bar

Model No.: YY2088C; YY2091C

Active Speaker System: YY2088C1; YY2091C1

Active Subwoofer: YY2088C2; YY2091C2

EUT Name	EUT Model No.
Active Subwoofer	YY2088C2

FCC ID: AK8YY2088C2

Prepared for : Sony Group Corporation
1-7-1 Konan Minato-ku Tokyo, 108-0075 Japan

Prepared By : Audix Technology (Shenzhen) Co., Ltd.
No. 6, Kefeng Road, Science & Technology Park,
Nanshan District , Shenzhen, Guangdong, China

Tel: (0755) 26639496



Report Number : ACS-F24190

Date of Test : Sep.02~Oct.23, 2024

Date of Report : Oct.24, 2024

TABLE OF CONTENTS

Description	Page
1. SUMMARY OF STANDARDS AND RESULTS.....	5
1.1. Description of Standards and Results	5
2. GENERAL INFORMATION.....	6
2.1. Description of Equipment Under Test	6
2.2. Channel list of EUT	7
2.3. Tested Supporting System Details	7
2.4. Block diagram of connection between the EUT and simulators.....	7
2.5. Test Facility	8
2.6. Measurement Uncertainty (95% confidence levels, k=2).....	8
3. POWER LINE CONDUCTED EMISSION TEST	9
3.1. Test Equipments.....	9
3.2. Block Diagram of Test Setup.....	9
3.3. Power Line Conducted Emission Test Limits.....	9
3.4. Configuration of EUT on Test	9
3.5. Operating Condition of EUT.....	10
3.6. Test Procedure	10
3.7. Power Line Conducted Emission Test Results	10
4. RADIATED EMISSION TEST	15
4.1. Test Equipment	15
4.2. Block Diagram of Test Setup.....	16
4.3. Radiated Emission Limit.....	17
4.4. EUT Configuration on Test	17
4.5. Operating Condition of EUT.....	17
4.6. Test Procedure	18
4.7. Radiated Emission Test Results.....	18
5. CONDUCTED SPURIOUS EMISSIONS.....	48
5.1. Test Equipment	48
5.2. Block Diagram of Test Setup.....	48
5.3. Limit.....	48
5.4. Test Procedure	48
5.5. Test result.....	48
6. BAND EDGE COMPLIANCE TEST	55
6.1. Test Equipment	55
6.2. Limit.....	55
6.3. Test Procedure.....	55
6.4. Test Results	55
7. 6dB & 99% Bandwidth Test	72
7.1. Test Equipment	72
7.2. Block Diagram of Test Setup.....	72
7.3. Limit.....	72
7.4. Test Procedure	72
7.5. Test Results	73
8. OUTPUT POWER TEST	82
8.1. Test Equipment	82
8.2. Limit (FCC Part 15C 15.247 b(3)).....	82
8.3. Test Procedure	82
8.4. Test Results	83

9.	POWER SPECTRAL DENSITY TEST.....	86
9.1.	Test Equipment	86
9.2.	Limit.....	86
9.3.	Test Procedure	86
9.4.	Test Results	86
10.	ANTENNA REQUIREMENT.....	89
10.1.	Standard Applicable.....	89
10.2.	Antenna Connected Construction	89
11.	DEVIATION TO TEST SPECIFICATIONS.....	90

- Appendix A. Setup Photographs
- Appendix B. General Appearance of the EUT
- Appendix C. Inside Configuration of the EUT

TEST REPORT CERTIFICATION

Applicant : Sony Group Corporation
 Product : Sound Bar
 Model No. : YY2088C; YY2091C
 Active Speaker System : YY2088C1; YY2091C1
 Active Subwoofer : YY2088C2; YY2091C2
 Brand : SONY
 FCC ID : AK8YY2088C2
 Test Voltage : AC 120V/60Hz

Tested for comply with:
 FCC CFR 47 Part 15 Subpart C

Test procedure used:
 ANSI C63.10:2020+COR1:2023
 KDB 558074 D01v05r02

The device described above is tested by AUDIX TECHNOLOGY (SHENZHEN) CO., LTD. to confirm comply with all the FCC Part 15 Subpart C requirements. The test results are contained in this test report and AUDIX TECHNOLOGY (SHENZHEN) CO., LTD. is assumed full responsibility for the accuracy and completeness of these tests. Also, this report shows that the Equipment Under Test (EUT) is to be technically compliant with the FCC and IC requirements. This report contains data that are not covered by the NVLAP accreditation.

This Report is made under FCC Part 2.1074. No modifications were required during testing to bring this product into compliance.

This report applies to single evaluation of one sample of above mentioned product. This report shall not be reproduced in part without written approval of AUDIX TECHNOLOGY (SHENZHEN) CO., LTD.

The report must not be used by the client to claim product certification, approval, or endorsement by NVLAP, NIST, or any agency of the federal government.

Date of Test : Sep.02~Oct.23, 2024 Date of Report: Oct.24, 2024

Prepared by : Dora Yang Reviewed by : Thomas Chen
 Dora Yang / Assistant Manager Thomas Chen / Assistant Manager

信華科技 (深圳) 有限公司
 Audix Technology (Shenzhen) Co., Ltd.
 EMC 部門報告專用章
 Stamp only for EMC Dept. Report
 Signature: Sunny Lu
 Sunny Lu / Manager

1. SUMMARY OF STANDARDS AND RESULTS

1.1. Description of Standards and Results

The EUT has been tested according to the applicable standards as referenced below.

EMISSION		
Description of Test Item	Standard	Results
Power Line Conducted Emission	FCC Part 15: 15.207 ANSI C63.10:2020+COR1:2023	PASS
Radiated Emission	FCC Part 15: 15.209 FCC Part 15: 15.205 FCC Part 15: 15.247(d) ANSI C63.10:2020+COR1:2023	PASS
Band Edge Compliance	FCC Part 15: 15.247(d) ANSI C63.10:2020+COR1:2023	PASS
Conducted spurious emissions	FCC Part 15: 15.247(d) ANSI C63.10:2020+COR1:2023	PASS
6dB Bandwidth Test	FCC Part 15: 15.247(a)(2) ANSI C63.10:2020+COR1:2023	PASS
Peak Output Power	FCC Part 15: 15.247(b)(3) ANSI C63.10:2020+COR1:2023	PASS
Power Spectral Density	FCC Part 15: 15.247(e) ANSI C63.10:2020+COR1:2023	PASS
Antenna requirement	FCC Part 15: 15.203	PASS

Note : Measurement uncertainty affection to the result is not considered, the EUT is technically compliant with standard requirements.

2. GENERAL INFORMATION

2.1. Description of Equipment Under Test

Applicant	Sony Group Corporation
Applicant Address	1-7-1 Konan Minato-ku Tokyo, 108-0075 Japan
Manufacturer	Sony Group Corporation
Manufacturer Address	1-7-1 Konan Minato-ku Tokyo, 108-0075 Japan
Product	Sound Bar
Model No.	YY2088C; YY2091C Model differences (Declared by the Applicant): Only model name different.
Active Speaker System	YY2088C1; YY2091C1
Active Subwoofer	YY2088C2; YY2091C2
Brand	SONY
EUT Name	Active Subwoofer
EUT Model No.	YY2088C2
FCC ID	AK8YY2088C2
Radio	BDR+EDR, BLE, SRD
Frequency Range	BT(BDR+EDR, BLE): 2402-2480MHz SRD: 2403-2479MHz
Type of Modulation(BT)	GFSK, $\pi/4$ DQPSK, 8DPSK
Type of Modulation(SRD)	GFSK
Remote Control	Manufacturer: Sony; Model: RMT-AH513U
Power Cord	Unshielded, Detachable, 1.5m (2 pins)
HDMI Cable	Shielded, Detachable, 1.5m
Sample Type	Prototype production
Date of Receipt	Aug.06, 2024
Date of Test	Sep.02~Oct.23, 2024
The EUT covered in this report is Active Subwoofer; This product (YY2088C,YY2091C) consists of Active Speaker System (YY2088C1,YY2091C) and Active Subwoofer (YY2088C2,YY2091C2).	

Antenna System	
Type of Antenna	Active Speaker System SRD: PCB antenna Active Speaker System BT: PCB Antenna Active Subwoofer SRD: PCB Antenna
Antenna Peak Gain	Active Speaker System SRD: 3.35dBi Active Speaker System BT: 2.1dBi Active Subwoofer SRD: 2.95dBi

2.2.Channel list of EUT

A special software (Syncomm Debug Tool v24.01.31) was used to control EUT work in 2.4G.

Channel	Frequency (MHz)	Channel	Frequency (MHz)	Channel	Frequency (MHz)
1	2403	8	2429	15	2457
2	2404	9	2436	16	2464
3	2407	10	2441	17	2469
4	2412	11	2449	18	2476
5	2417	12	2450	19	2479
6	2424	13	2452	---	---
7	2425	14	2455	---	---

2.3.Tested Supporting System Details

No.	Description	ACS No.	Manufacturer	Model	Serial Number
1.	Notebook	N/A	ACER	ZOW	N/A
Power Cord(3C): Unshielded, Detachable, 1.8m Power Adaptor: Manufacturer: Lite-On, M/N: PA-1900-32 Cable: Unshielded, Undetectable, 4.0m(Bond one ferrite core)					

2.4.Block diagram of connection between the EUT and simulators

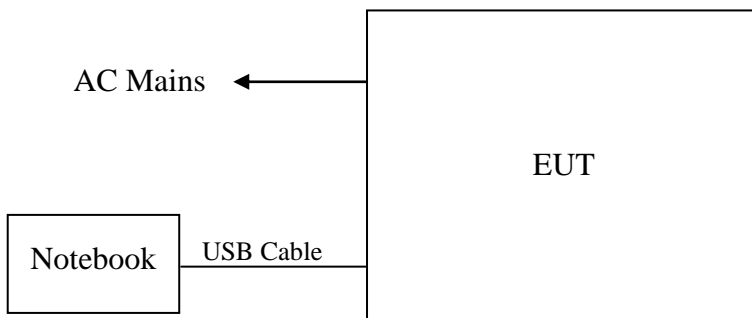

(EUT: Active Subwoofer)

2.5. Test Facility

Site Description

Name of Firm : Audix Technology (Shenzhen) Co., Ltd.
 : No. 6, Kefeng Road, Science & Technology Park,
 Nanshan District , Shenzhen, Guangdong, China

EMC Lab. : Certified by ISED, Canada
 : Company Number: 5183A
 : CAB identifier: CN0034
 : Valid Date: Mar.31, 2025

: Certified by FCC, USA
 : Designation No.: CN5022
 : Valid Date: Mar.31, 2025

: Accredited by NVLAP, USA
 : NVLAP Code: 200372-0
 : Valid Date: Mar.31, 2026

2.6.Measurement Uncertainty (95% confidence levels, k=2)

Test Item	Uncertainty
Uncertainty for Conduction emission test in No. 1 Conduction	$\pm 2.6\text{dB}(150\text{KHz to } 30\text{MHz})$
Uncertainty for Radiation Emission test in 3m chamber	$\pm 3.8\text{dB}(30\sim 200\text{MHz, Polarization: H})$
	$\pm 3.8\text{dB}(30\sim 200\text{MHz, Polarization: V})$
	$\pm 4.0\text{dB}(200\text{M}\sim 1\text{GHz, Polarization: H})$
	$\pm 4.0\text{dB}(200\text{M}\sim 1\text{GHz, Polarization: V})$
Uncertainty for Radiation Emission test in 3m chamber(1GHz-18GHz)	$\pm 4.0\text{dB}(1\sim 6\text{GHz, Distance: } 3\text{m})$
	$\pm 4.0\text{dB}(6\sim 18\text{GHz, Distance: } 3\text{m})$
Uncertainty for S_{vswr} in 3m Chamber	$\pm 2.8\text{dB}(1\sim 6\text{GHz})$
	$\pm 2.8\text{dB}(6\sim 18\text{GHz})$
Uncertainty for Radiated Spurious Emission test in RF chamber	$\pm 3.7\text{dB}(30\text{MHz}\sim 1000\text{MHz})$
	$\pm 3.3\text{dB}(1\sim 26.5\text{GHz})$
Uncertainty for Conduction Spurious emission test	$\pm 2.0\text{dB}$
Uncertainty for Output power test	$\pm 0.8\text{dB}$
Uncertainty for Bandwidth test	$\pm 4.6\%$
Uncertainty for DC power test	$\pm 0.1\%$
Uncertainty for test site temperature and humidity	$\pm 0.6^{\circ}\text{C}$
	$\pm 3\%$

3. POWER LINE CONDUCTED EMISSION TEST

3.1. Test Equipments

Item	Equipment	Manufacturer	Model No.	Serial No.	Last Cal.	Cal. Interval
1.	1# Shielding Room	AUDIX	N/A	N/A	Nov.09,22	3 Year
2.	EMI Test Receiver	Rohde & Schwarz	ESCI	100842	Mar.16,24	1 Year
3.	L.I.S.N.#1	Rohde & Schwarz	ENV216	102160	Jun.19,24	1 Year
4.	RF Cable	Eastsheep	RG223	190424	Sep.12,24	1 Year
5.	Test Software	AUDIX	e3	6.100913a	N/A	N/A

Note: N/A means Not applicable.

3.2. Block Diagram of Test Setup

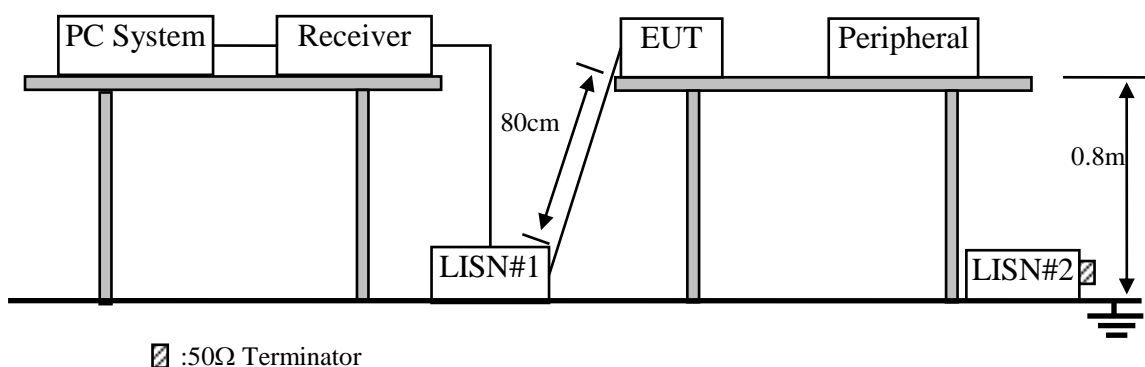

3.3. Power Line Conducted Emission Test Limits

Frequency	Maximum RF Line Voltage	
	Quasi-Peak Level dB(μV)	Average Level dB(μV)
150kHz ~ 500kHz	66 ~ 56*	56 ~ 46*
500kHz ~ 5MHz	56	46
5MHz ~ 30MHz	60	50

Notes: 1. * Decreasing linearly with logarithm of frequency.

2. The lower limit shall apply at the transition frequencies.

3.4. Configuration of EUT on Test

The following equipment are installed on Power Line Conducted Emission Test to meet the commission requirement and operating regulations in a manner which tends to maximize its emission characteristics in a normal application.

3.4.1. Active Subwoofer (EUT)

Model No. : YY2088C2

Serial No. : N/A

3.4.2. Support Equipment: As Tested Supporting System Details, in Section 2.2.

3.5. Operating Condition of EUT

3.5.1. Setup the EUT and simulator as shown as Section 3.2.

3.5.2. Turn on the power of all equipments.

3.5.3. PC run test software to control EUT work in General 2.4G Tx mode.

3.6. Test Procedure

The EUT was placed on a non-metallic table, 80cm above the ground plane. The EUT Power Via AC unit connected to the power mains through a line impedance stabilization network (L.I.S.N.). This provides a 50 ohm coupling impedance for the EUT (Please refer the block diagram of the test setup and photographs). The AC line are checked to find out the maximum conducted emission. In order to find the maximum emission levels, the relative positions of equipment and all of the interface cables shall be changed according to ANSI C63.10 on Conducted Emission Test.

The bandwidth of test receiver (R & S ESCI) is set at 9kHz.

The frequency range from 150kHz to 30MHz is checked.

3.7. Power Line Conducted Emission Test Results

PASS. (All emissions not reported below are too low against the prescribed limits.)

ANT A

Data: 11

File: E:\1#CE\2024 Report Data\SONYA1Z2408012-RF.EM6 (12)

Date: 2024-09-30

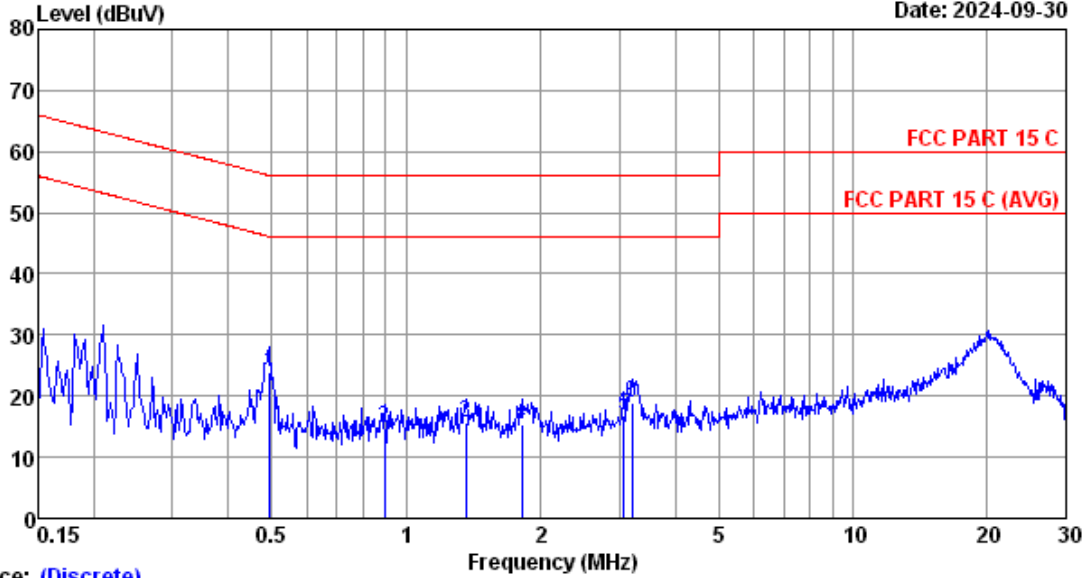

Trace: (Discrete)

Site no :1# CE Data No :11
 Dis./Lisn :2024 ENV216-N
 Limit :FCC PART 15 C
 Env./Ins. :24.2*C/54% Engineer :Hongjie
 Power Rating :AC 120V/60Hz
 Test Mode :2.4G TX Mode

No	Freq (MHz)	LISN Factor (dB)	Cable Loss (dB)	Reading (dBuV)	Emission Level (dBuV)	Limits (dBuV)	Margin (dB)	Remark
1	0.494	9.78	0.02	14.13	23.93	56.10	32.17	QP
2	0.894	9.80	0.02	4.85	14.67	56.00	41.33	QP
3	1.359	9.80	0.03	5.69	15.52	56.00	40.48	QP
4	1.819	9.80	0.04	5.61	15.45	56.00	40.55	QP
5	3.074	9.81	0.05	6.94	16.80	56.00	39.20	QP
6	3.207	9.81	0.05	8.98	18.84	56.00	37.16	QP

Remarks: 1.Emission Level=LISN Factor+Cable Loss+Reading.
 2.If the average limit is met when using a quasi-peak detector. the EUT shall be deemed to meet both limits and measurement with average detector is unnecessary.

Data: 12 File: E:\1#CE\2024 Report Data\SI\SONYA1Z2408012-RF.EM6 (12) Date: 2024-09-30

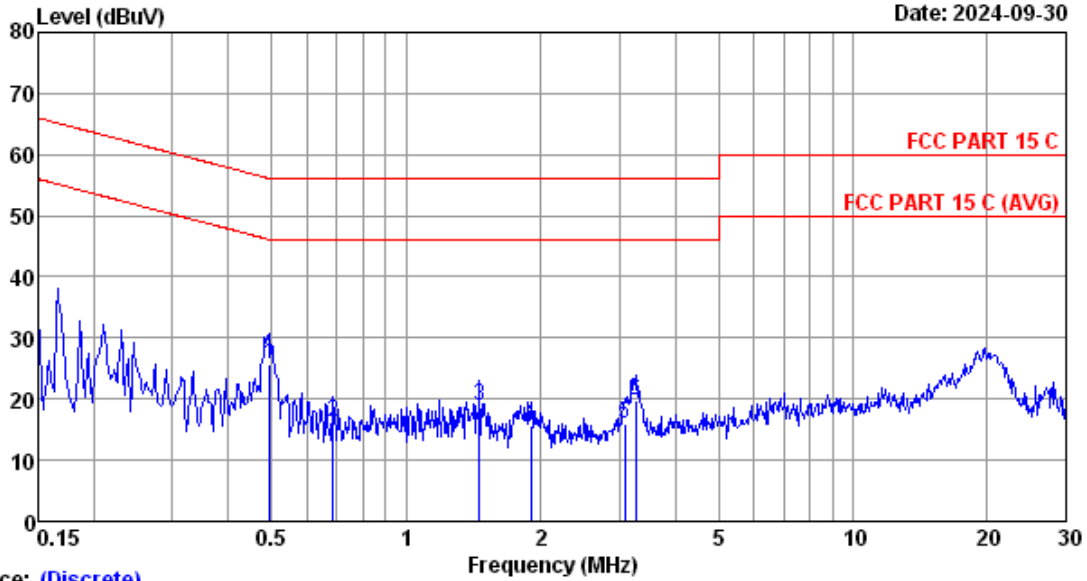

Trace: (Discrete)

Site no :1# CE Data No :12
 Dis./Lisn :2024 ENV216-L
 Limit :FCC PART 15 C
 Env./Ins. :24.2*C/54% Engineer :Hongjie
 Power Rating :AC 120V/60Hz
 Test Mode :2.4G TX Mode

No	Freq (MHz)	LISN Factor (dB)	Cable Loss (dB)	Reading (dBuV)	Emission Level (dBuV)	Limits (dBuV)	Margin (dB)	Remark
1	0.494	9.76	0.02	15.94	25.72	56.10	30.38	QP
2	0.686	9.77	0.02	6.59	16.38	56.00	39.62	QP
3	1.456	9.78	0.03	9.07	18.88	56.00	37.12	QP
4	1.898	9.78	0.04	5.78	15.60	56.00	40.40	QP
5	3.090	9.80	0.05	6.14	15.99	56.00	40.01	QP
6	3.258	9.80	0.05	9.95	19.80	56.00	36.20	QP

Remarks: 1.Emission Level=LISN Factor+Cable Loss+Reading.
 2.If the average limit is met when using a quasi-peak detector, the EUT shall be deemed to meet both limits and measurement with average detector is unnecessary.

ANT B

Data: 9

File: E:\1#CE\2024 Report Data\SI\SONYA1Z2408012-RF.EM6 (12)

Date: 2024-09-30

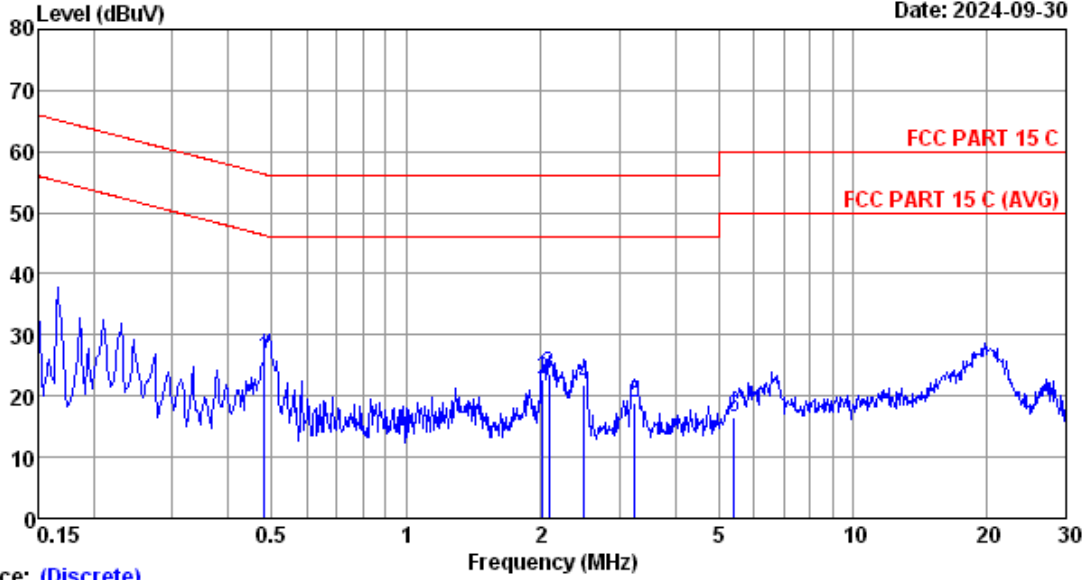

Trace: (Discrete)

Site no :1# CE Data No :9
 Dis./Lisn :2024 ENV216-L
 Limit :FCC PART 15 C
 Env./Ins. :24.2*C/54% Engineer :Hongjie
 Power Rating :AC 120V/60Hz
 Test Mode :2.4G TX Mode

No	Freq (MHz)	LISN Factor (dB)	Cable Loss (dB)	Reading (dBuV)	Emission Level (dBuV)	Limits (dBuV)	Margin (dB)	Remark
1	0.481	9.76	0.02	16.35	26.13	56.32	30.19	QP
2	2.023	9.78	0.04	12.80	22.62	56.00	33.38	QP
3	2.088	9.78	0.04	13.72	23.54	56.00	32.46	QP
4	2.500	9.79	0.04	12.11	21.94	56.00	34.06	QP
5	3.241	9.80	0.05	9.03	18.88	56.00	37.12	QP
6	5.419	9.82	0.06	6.77	16.65	60.00	43.35	QP

Remarks: 1.Emission Level=LISN Factor+Cable Loss+Reading.
 2.If the average limit is met when using a quasi-peak detector. the EUT shall be deemed to meet both limits and measurement with average detector is unnecessary.

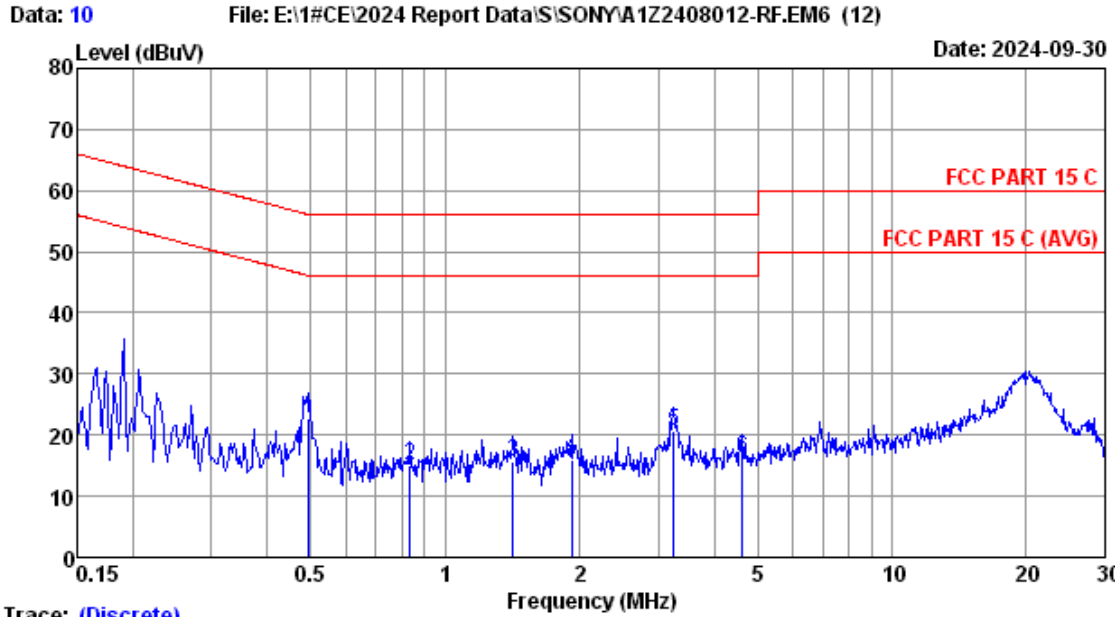

Trace: (Discrete)

Site no :1# CE Data No :10
 Dis./Lisn :2024 ENV216-N
 Limit :FCC PART 15 C
 Env./Ins. :24.2*C/54% Engineer :Hongjie
 Power Rating :AC 120V/60Hz
 Test Mode :2.4G TX Mode

No	Freq (MHz)	LISN Factor (dB)	Cable Loss (dB)	Reading (dBuV)	Emission Level (dBuV)	Limits (dBuV)	Margin (dB)	Remark
1	0.494	9.78	0.02	12.98	22.78	56.10	33.32	QP
2	0.835	9.79	0.02	5.23	15.04	56.00	40.96	QP
3	1.418	9.80	0.03	5.81	15.64	56.00	40.36	QP
4	1.918	9.80	0.04	6.22	16.06	56.00	39.94	QP
5	3.241	9.81	0.05	10.72	20.58	56.00	35.42	QP
6	4.622	9.83	0.06	6.27	16.16	56.00	39.84	QP

Remarks: 1.Emission Level=LISN Factor+Cable Loss+Reading.
 2.If the average limit is met when using a quasi-peak detector.
 the EUT shall be deemed to meet both limits and measurement
 with average detector is unnecessary.

4. RADIATED EMISSION TEST

4.1. Test Equipment

4.1.1. For frequency range 30MHz~1000MHz (In 3m Anechoic Chamber)

Item	Equipment	Manufacturer	Model No.	Serial No.	Last Cal.	Cal. Interval
1.	3m Chamber(NSA)	AUDIX	N/A	N/A	Aug.11,22	3Year
2.	3m Chamber(SE)	AUDIX	N/A	N/A	Sep.16,22	3 Year
3.	Signal Analyzer	Rohde & Schwarz	FSV40	101608	Nov.07,23	1 Year
4.	Tri-log-Broadband Antenna	SCHWARZBECK	VULB 9168	429	Oct.10,23	1 Year
5.	NSA Cable	HUBER+SUHNER	CFD400NL-LW	No.3+190411	Sep.13,24	1 Year
6.	Coaxial Switch	Anritsu	MP59B	6201397223	Mar.17,24	1 Year
7.	EMI Test Receiver	Rohde & Schwarz	ESR3	101931	Mar.17,24	1 Year
8.	Amplifier	HP	8447D	2944A11159	Mar.17,24	1 Year
9.	Test Software	AUDIX	e3	6.100913a	N/A	N/A

Note: N/A means Not applicable.

4.1.2. For frequency range 1GHz~25GHz (In 3m Anechoic Chamber)

Item	Equipment	Manufacturer	Model No.	Serial No.	Last Cal.	Cal. Interval
1.	3mChamber(Svswr)	AUDIX	N/A	N/A	Aug.09,22	3Year
2.	3mChamber(SE)	AUDIX	N/A	N/A	Sep.16,22	3Year
3.	Signal Analyzer	Rohde & Schwarz	FSV40	101608	Nov.07,23	1 Year
4.	Amplifier	EMCI	EMC0518A45SE	980965	Aug.13,24	1 Year
5.	RF Cable	TIMES MICROWAVE	SFT205-NMSM-1 0.00M	689241	Aug.13,24	1 Year
6.	Test Software	AUDIX	e3	6.100913a	N/A	N/A
7.	Horn Antenna	EMCO	3115	9510-4580	Jan.08,22	3 Year

Note: N/A means Not applicable.

4.2. Block Diagram of Test Setup

For frequency range 30MHz-1000MHz

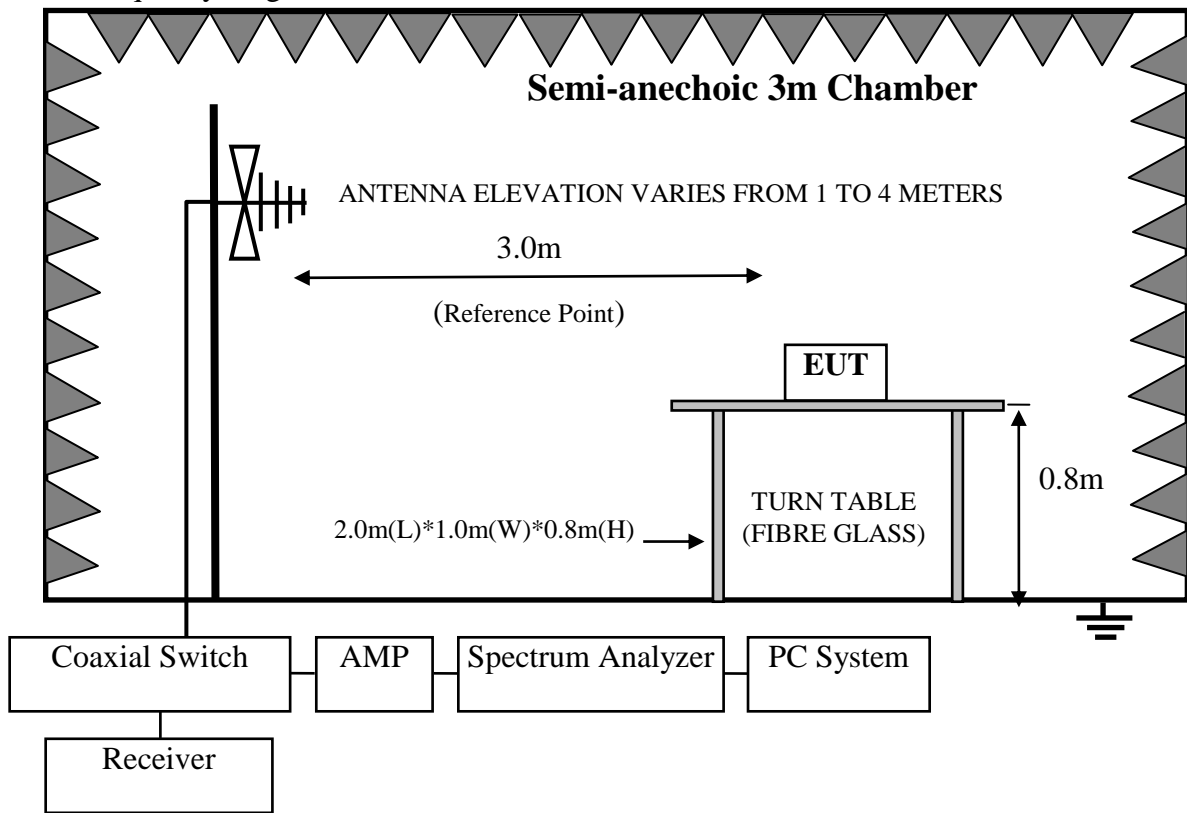

For frequency range 1GHz-25GHz

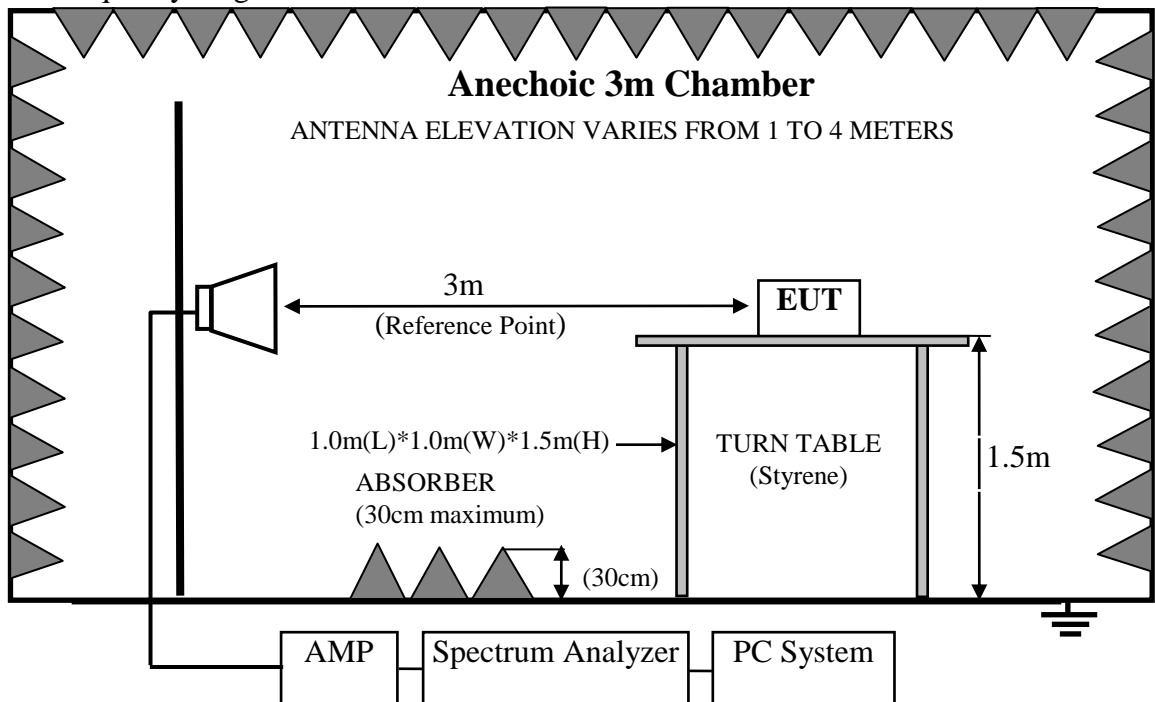

4.3.Radiated Emission Limit

4.3.1. 15.247&209 limits

FREQUENCY MHz	DISTANCE Meters	FIELD STRENGTHS LIMIT	
		μV/m	dB(μV)/m
30 ~ 88	3	100	40.0
88 ~ 216	3	150	43.5
216 ~ 960	3	200	46.0
960 ~ 1000	3	500	54.0
Above 1000	3	74.0 dB(μV)/m (Peak) 54.0 dB(μV)/m (Average)	

Remark : (1) Emission level dBμV = 20 log Emission level μV/m

- (2) The smaller limit shall apply at the cross point between two frequency bands.
- (3) Distance is the distance in meters between the measuring instrument, antenna and the closest point of any part of the device or system.

4.3.2. 15.205 Restricted bands of operation

MHz	MHz	MHz	GHz
0.090 - 0.110	16.42 - 16.423	399.9 - 410	4.5 - 5.15
0.495 - 0.505	16.69475 - 16.69525	608 - 614	5.35 - 5.46
2.1735 - 2.1905	16.80425 - 16.80475	960 - 1240	7.25 - 7.75
4.125 - 4.128	25.5 - 25.67	1300 - 1427	8.025 - 8.5
4.17725 - 4.17775	37.5 - 38.25	1435 - 1626.5	9.0 - 9.2
4.20725 - 4.20775	73 - 74.6	1645.5 - 1646.5	9.3 - 9.5
6.215 - 6.218	74.8 - 75.2	1660 - 1710	10.6 - 12.7
6.26775 - 6.26825	108 - 121.94	1718.8 - 1722.2	13.25 - 13.4
6.31175 - 6.31225	123 - 138	2200 - 2300	14.47 - 14.5
8.291 - 8.294	149.9 - 150.05	2310 - 2390	15.35 - 16.2
8.362 - 8.366	156.52475 - 156.52525	2483.5 - 2500	17.7 - 21.4
8.37625 - 8.38675	156.7 - 156.9	2690 - 2900	22.01 - 23.12
8.41425 - 8.41475	162.0125 - 167.17	3260 - 3267	23.6 - 24.0
12.29 - 12.293	167.72 - 173.2	3332 - 3339	31.2 - 31.8
12.51975 - 12.52025	240 - 285	3345.8 - 3358	36.43 - 36.5
12.57675 - 12.57725	322 - 335.4	3600 - 4400	(²)

All the emissions appearing within 15.205 restricted frequency bands shall not exceed the limits shown in 15.209, all the other emissions shall be at least 20dB below the fundamental emissions, or comply with 15.209 limits.

4.4.EUT Configuration on Test

The configurations of EUT are listed in Section 3.4.

4.5.Operating Condition of EUT

Same as Conducted Emission test that is listed in Section 3.5.

4.6. Test Procedure

Frequency below 30MHz:

The EUT setup on the turn table which has 0.8 m height to the ground. The turn table rotated 360 degrees and antenna fixed to 1 m to find the maximum emission level. In order to find the maximum emission, all of the interface cables were manipulated according to ANSI C63.10-2013 regulation.

EUT and its simulators are placed on a turn table, which is 0.8 meter high above ground for frequency 30MHz~1000MHz, 1.5 meter high above ground for frequency above 1GHz and put the absorbing with 2.4m(L)*2.4m(W)*0.3m(H) on the ground . The turn table can rotate 360 degrees to determine the position of the maximum emission level. Power on the EUT and let it working in test mode, then test it. EUT is set 3 meters away from the receiving antenna, which is mounted on a antenna tower. The antenna can be moved up and down between 1 meter and 4 meters to find out the maximum emission level. Broadband antenna (calibrated bilog antenna) is used as receiving antenna for frequency 30MHz~1000MHz, and the Horn antenna is used as receiving antenna for frequency above 1GHz. Both horizontal and vertical polarization of the antenna is set on Test. In order to find the maximum emission levels, all of the interface cables must be manipulated according to ANSI C63.10 on radiated emission Test.

This test was performed with EUT in X, Y, Z position, and the worse case was found when EUT in X position as test photo indicated.

The bandwidth of the EMI test receiver (R&S ESR7) is set at 120kHz for frequency range from 30MHz to 1000 MHz.

The bandwidth of the Spectrum's VBW is set at 3MHz and RBW is set at 1MHz for peak emissions measurement above 1GHz.

This device is pulse modulated, a duty cycle factor was used to calculate average level based measured peak level.

The frequency range from 30MHz to 10th harmonic (25GHz) is checked. And no any emissions were found from 18GHz to 25 GHz, So the radiated emissions from 18GHz to 25GHz were not record.

4.7. Radiated Emission Test Results

PASS.

All the emissions from 30MHz to 25 GHz were comply with 15.209 limits.

Note 1: The duty cycle factor for calculate average level is 1dB.

Note 2: The emissions (9kHz~30MHz) not reported for there is no emission be found.

ANT A

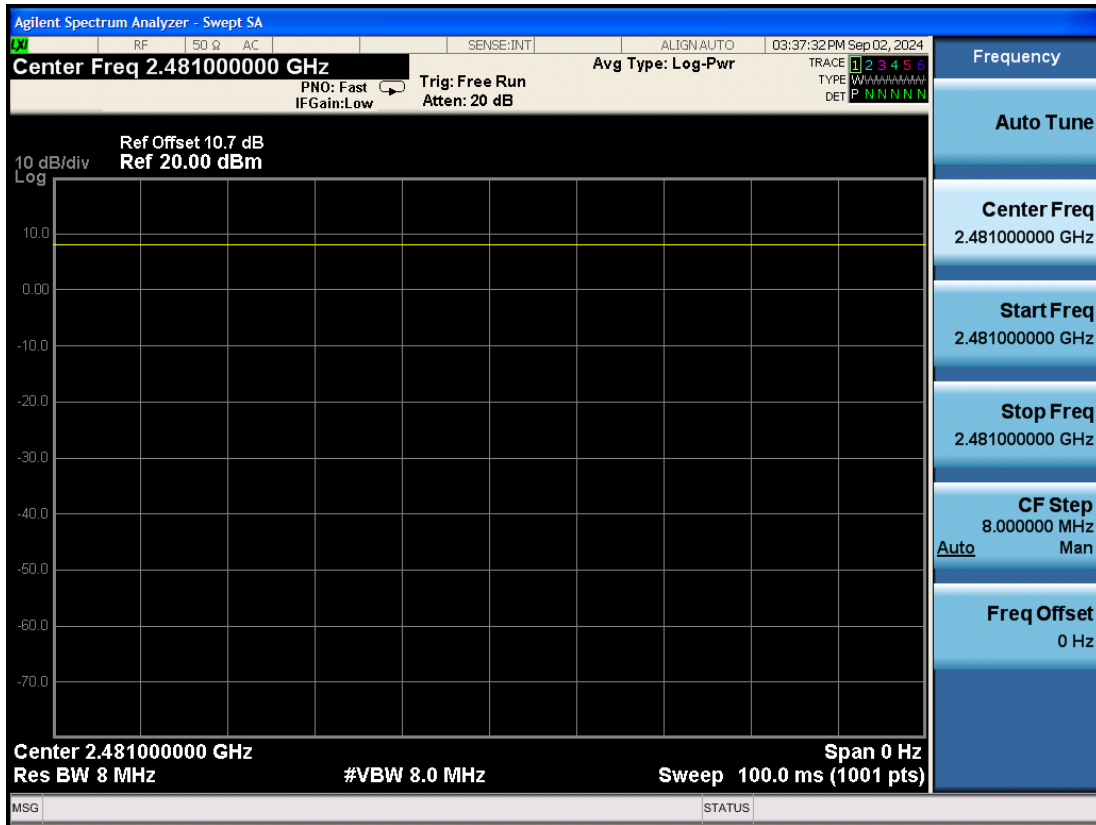

ANT B

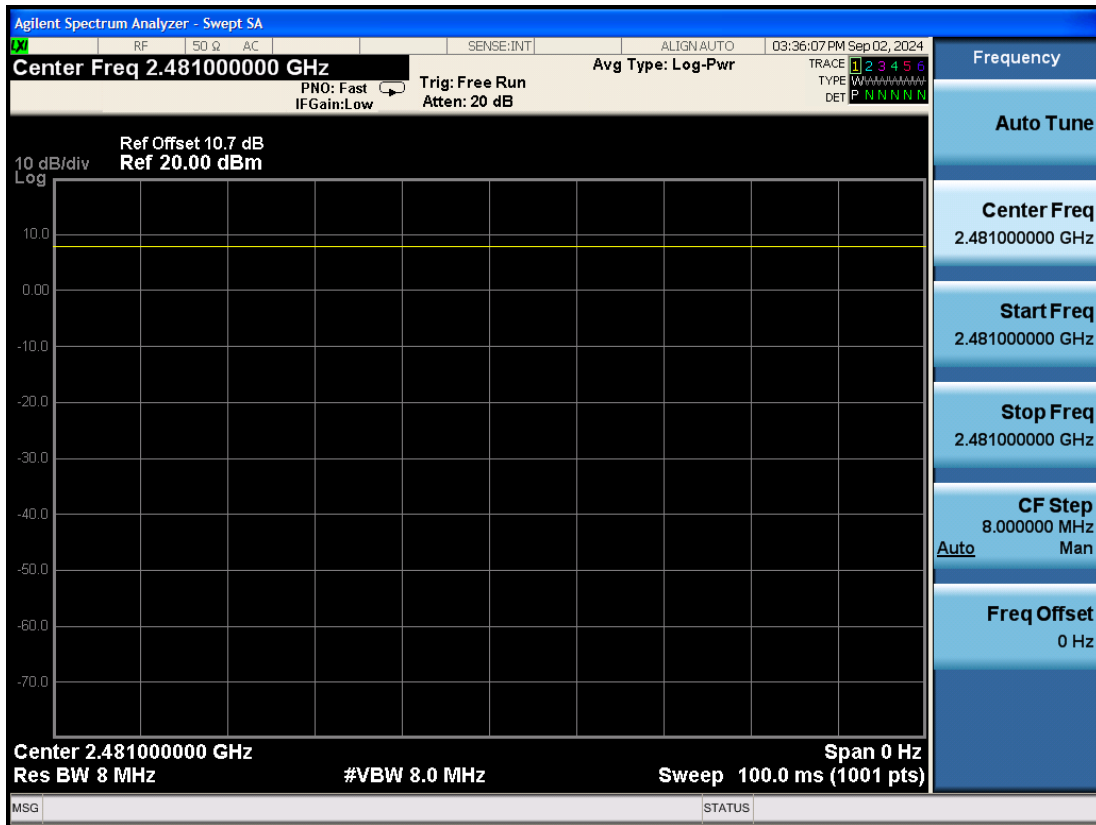

Note: Duty cycle 100%.

Frequency: 30MHz~1GHz

ANT A

Data: 9

File: F:\2024 Report\SI\SONYA\1Z2408012\A\1Z2408012-RF.EM6 (12)

Date: 2024-09-26

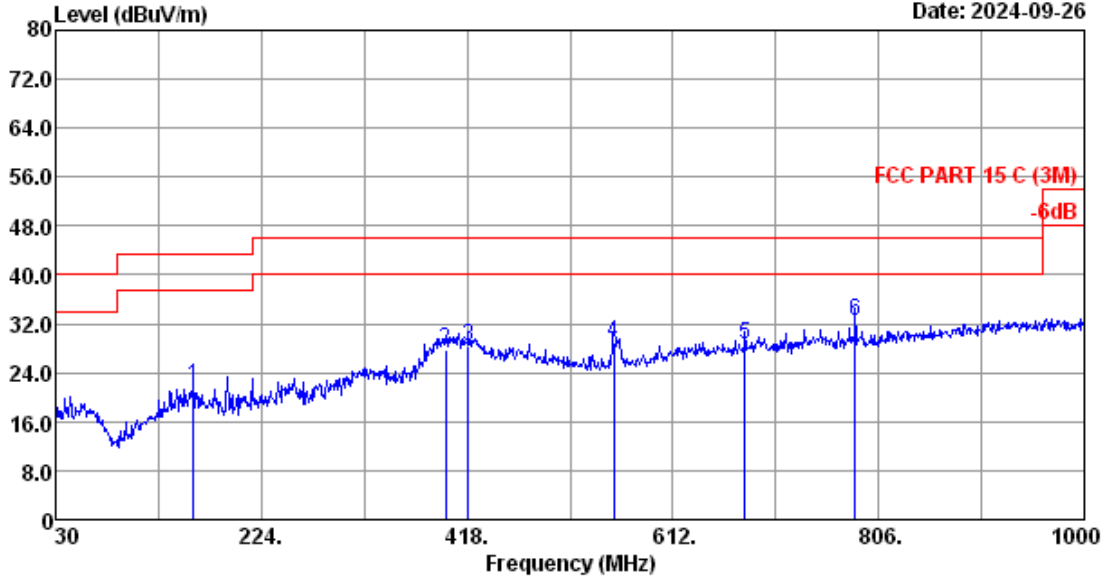

Site no. : 3m Chamber Data no. : 9
 Dis. / Ant. : 3m 2023 VULB 9168-429 Ant. pol. : HORIZONTAL
 Limit : FCC PART 15 C (3M)
 Env. / Ins. : 22.9*C/53% Engineer : Abel
 Test Mode : 2.4G TX MODE

No.	Freq. (MHz)	Ant. Factor (dB/m)	Cable Loss (dB)	Reading (dBuV)	Emission Level (dBuV/m)	Limits (dBuV/m)	Margin (dB)	Remark
1	159.98	19.20	1.04	1.49	21.73	43.50	21.77	QP
2	397.63	21.45	1.63	4.75	27.83	46.00	18.17	QP
3	418.97	22.26	1.67	4.51	28.44	46.00	17.56	QP
4	556.71	24.63	1.95	2.38	28.96	46.00	17.04	QP
5	679.90	26.60	2.19	-0.22	28.57	46.00	17.43	QP
6	783.69	28.27	2.35	1.94	32.56	46.00	13.44	QP

Remarks: 1. Emission Level= Antenna Factor + Cable Loss + Reading - Amp factor.
 2. The emission levels that are 20dB below the official limit are not reported.

Data: 10 File: F:\2024 Report\SI\SONYA1Z2408012\A1Z2408012-RF.EM6 (12) Date: 2024-09-26

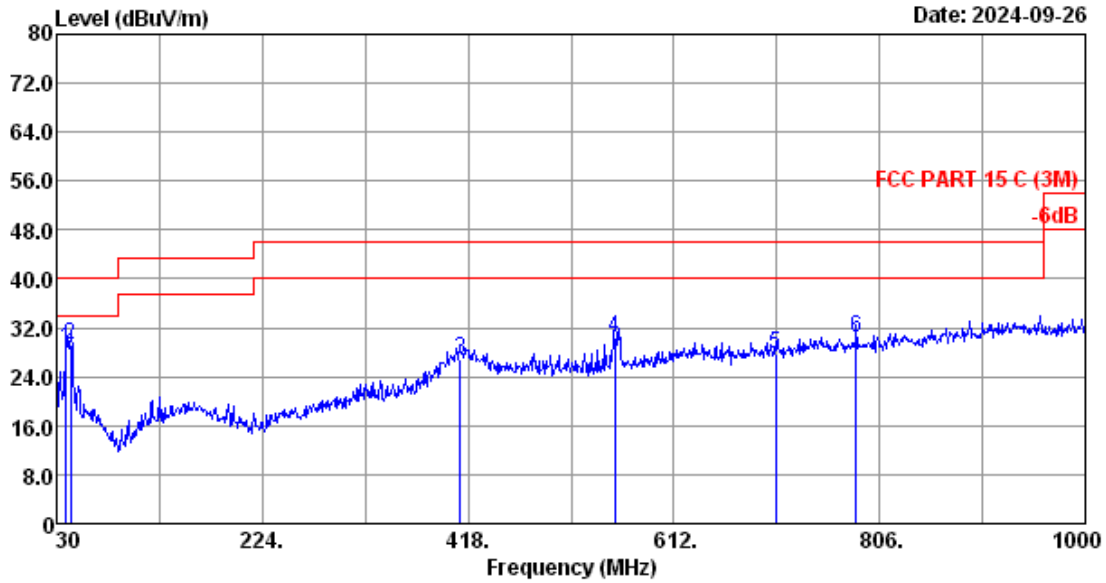

Site no. : 3m Chamber Data no. : 10
 Dis. / Ant. : 3m 2023 VULB 9168-429 Ant. pol. : VERTICAL
 Limit : FCC PART 15 C (3M)
 Env. / Ins. : 22.9°C/53% Engineer : Abel
 Test Mode : 2.4G TX MODE

No.	Freq. (MHz)	Ant. Factor (dB/m)	Cable Loss (dB)	Reading (dBuV)	Emission Level (dBuV/m)	Limits (dBuV/m)	Margin (dB)	Remark
1	38.73	19.20	0.56	9.02	28.78	40.00	11.22	QP
2	43.58	19.54	0.60	9.01	29.15	40.00	10.85	QP
3	410.24	21.91	1.65	3.30	26.86	46.00	19.14	QP
4	556.71	24.63	1.95	3.73	30.31	46.00	15.69	QP
5	708.03	26.82	2.22	-1.19	27.85	46.00	18.15	QP
6	783.69	28.27	2.35	-0.21	30.41	46.00	15.59	QP

Remarks: 1. Emission Level= Antenna Factor + Cable Loss + Reading - Amp factor.
 2. The emission levels that are 20dB below the official limit are not reported.

ANT B

Data: 11

File: F:\2024 Report\SONY\A1Z2408012\A1Z2408012-RF.EM6 (12)

Date: 2024-09-26

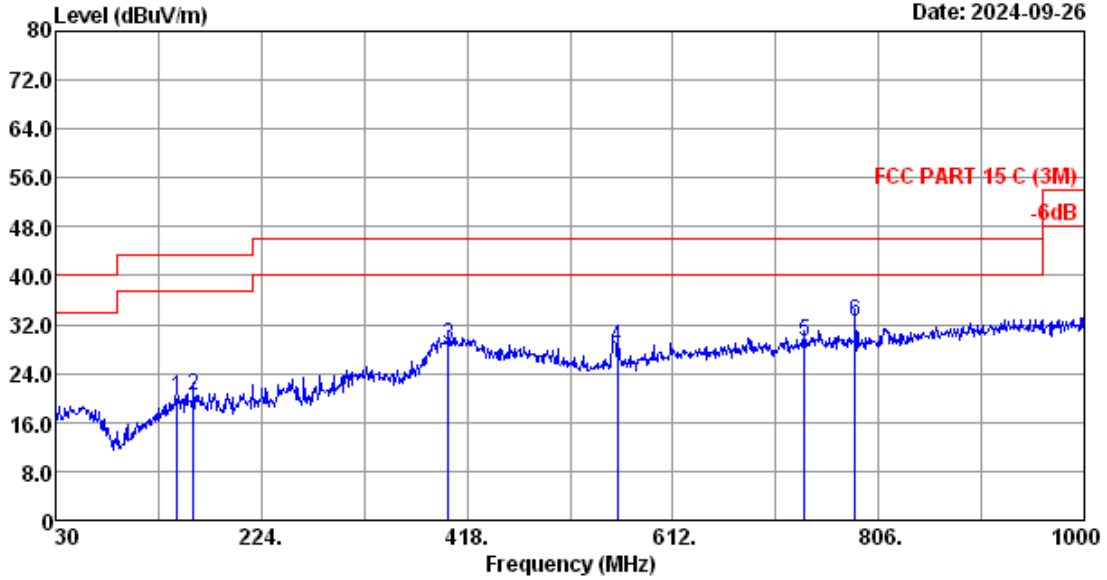

Site no. : 3m Chamber Data no. : 11
 Dis. / Ant. : 3m 2023 VULB 9168-429 Ant. pol. : HORIZONTAL
 Limit : FCC PART 15 C (3M)
 Env. / Ins. : 22.9°C/53% Engineer : Abel
 Test Mode : 2.4G TX MODE

No.	Freq. (MHz)	Ant. Factor (dB/m)	Cable Loss (dB)	Reading (dBuV)	Emission Level (dBuV/m)	Limits (dBuV/m)	Margin (dB)	Remark
1	144.46	19.30	1.00	-0.35	19.95	43.50	23.55	QP
2	159.98	19.20	1.04	0.25	20.49	43.50	23.01	QP
3	400.54	21.52	1.63	5.54	28.69	46.00	17.31	QP
4	559.62	24.69	1.96	1.61	28.26	46.00	17.74	QP
5	736.16	27.62	2.28	-0.80	29.10	46.00	16.90	QP
6	783.69	28.27	2.35	1.96	32.58	46.00	13.42	QP

Remarks: 1. Emission Level= Antenna Factor + Cable Loss + Reading - Amp factor.
 2. The emission levels that are 20dB below the official limit are not reported.

Data: 12 File: F:\2024 Report\SONYA1Z2408012\A1Z2408012-RF.EM6 (12) Date: 2024-09-26

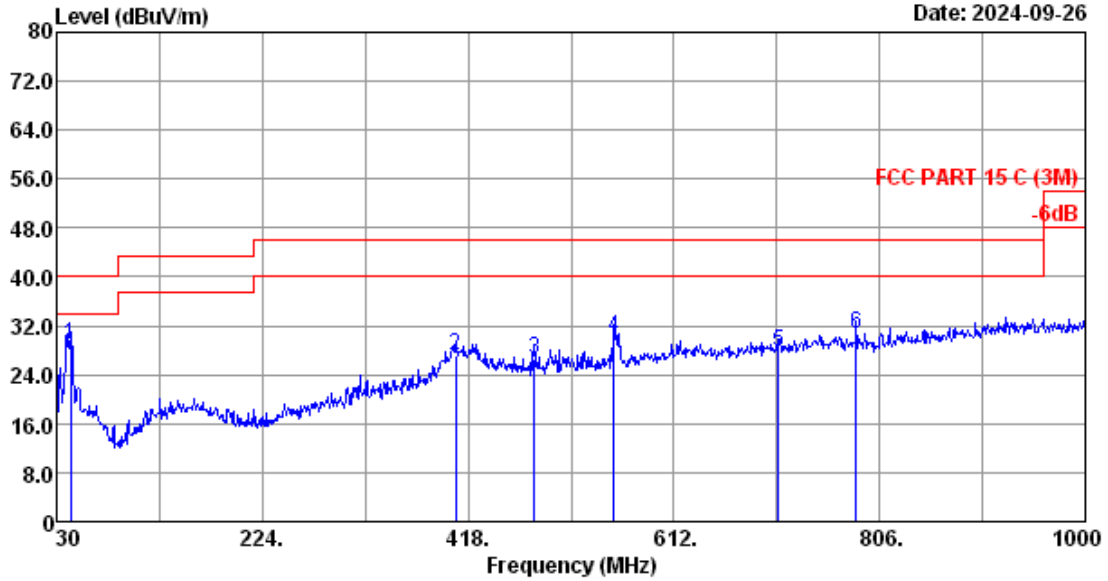

Site no. : 3m Chamber Data no. : 12
 Dis. / Ant. : 3m 2023 VULB 9168-429 Ant. pol. : VERTICAL
 Limit : FCC PART 15 C (3M)
 Env. / Ins. : 22.9°C/53% Engineer : Abel
 Test Mode : 2.4G TX MODE

No.	Freq. (MHz)	Ant. Factor (dB/m)	Cable Loss (dB)	Reading (dBuV)	Emission Level (dBuV/m)	Limits (dBuV/m)	Margin (dB)	Remark
1	43.58	19.54	0.60	8.80	28.94	40.00	11.06	QP
2	406.36	21.75	1.64	3.76	27.15	46.00	18.85	QP
3	480.08	23.40	1.79	1.37	26.56	46.00	19.44	QP
4	555.74	24.61	1.95	3.53	30.09	46.00	15.91	QP
5	710.94	26.92	2.23	-1.31	27.84	46.00	18.16	QP
6	783.69	28.27	2.35	0.15	30.77	46.00	15.23	QP

Remarks: 1. Emission Level= Antenna Factor + Cable Loss + Reading -Amp factor.
 2. The emission levels that are 20dB below the official limit are not reported.

Frequency: 1GHz~18GHz

ANT A

Data: 125

File: F:\2024 Report\SI\SONYA1Z2408012\A1Z2408012.EM6 (148)

Date: 2024-09-29

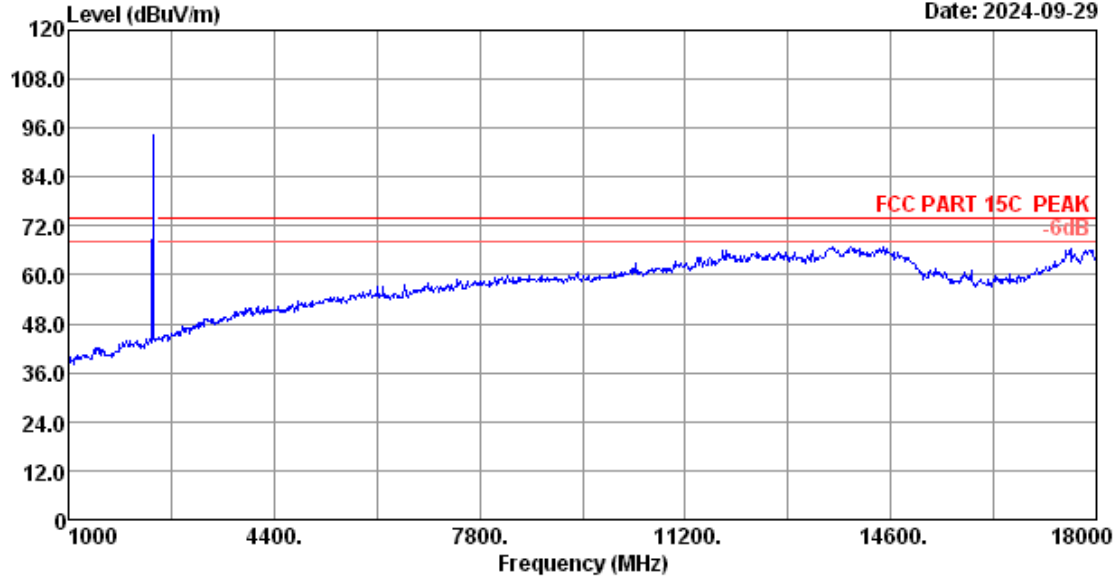

Site no.	: 3m Chamber	Data no.	: 125
Dis. / Ant.	: 3m 2022 3115-4580	Ant. pol.	: HORIZONTAL
Limit	: FCC PART 15C PEAK		
Env. / Ins.	: 21.8°C/53.9%	Engineer	: epoch
Test Mode	: 2.4G 2403MHz ANTA TX Mode		

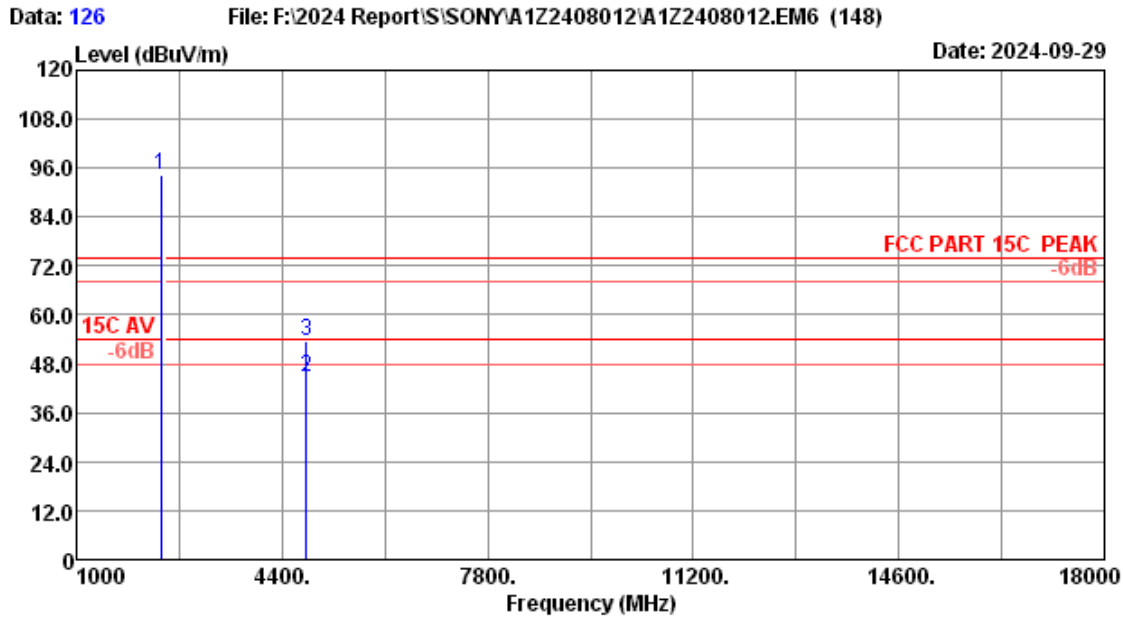

Site no. : 3m Chamber Data no. : 126
 Dis. / Ant. : 3m 2022 3115-4580 Ant. pol. : HORIZONTAL
 Limit : FCC PART 15C PEAK
 Env. / Ins. : 21.8°C/53.9% Engineer : epoch
 Test Mode : 2.4G 2403MHz ANTA TX Mode

No.	Freq. (MHz)	Ant. Factor (dB/m)	Cable Loss (dB)	Reading (dBUV)	Amp factor (dB)	Emission Level (dBUV/m)	Limits (dBUV/m)	Margin (dB)	Remark
1	2403.00	28.11	5.32	92.71	31.70	94.44	-----	-----	Peak
2	4806.00	32.71	7.41	34.95	30.42	44.65	54.00	9.35	Average
3	4806.00	32.71	7.41	43.82	30.42	53.52	74.00	20.48	Peak

Remarks: 1. Emission Level= Antenna Factor + Cable Loss + Reading -Amp factor.
 2. The emission levels that are 20dB below the official limit are not reported.

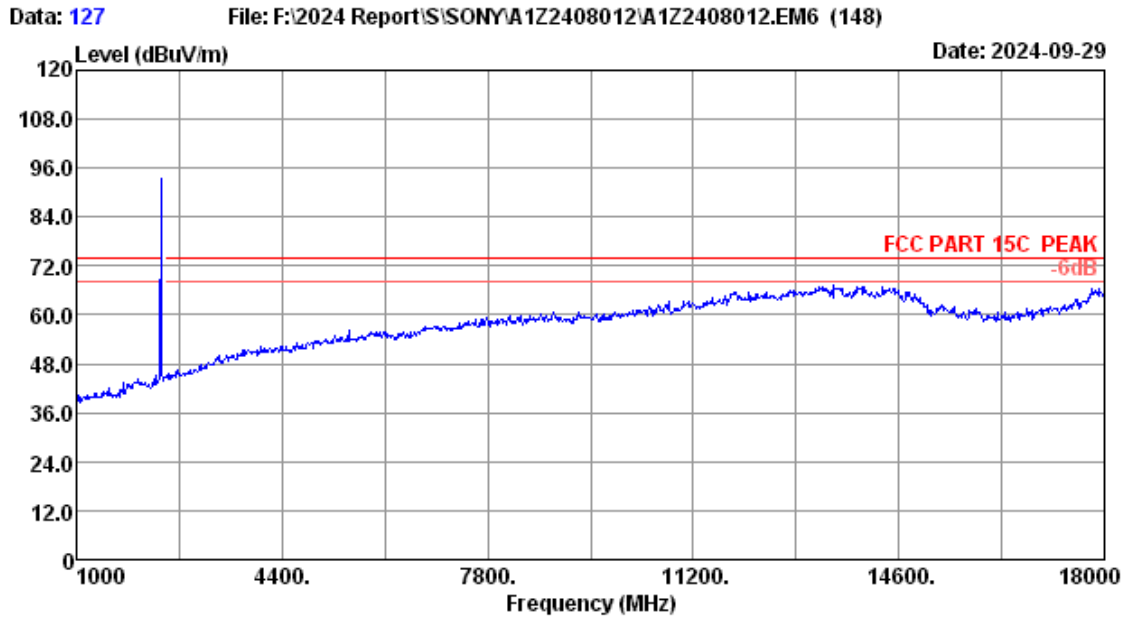

Site no.	: 3m Chamber	Data no.	: 127
Dis. / Ant.	: 3m 2022 3115-4580	Ant. pol.	: VERTICAL
Limit	: FCC PART 15C PEAK		
Env. / Ins.	: 21.8°C/53.9%	Engineer	: epoch
Test Mode	: 2.4G 2403MHz ANTA TX Mode		

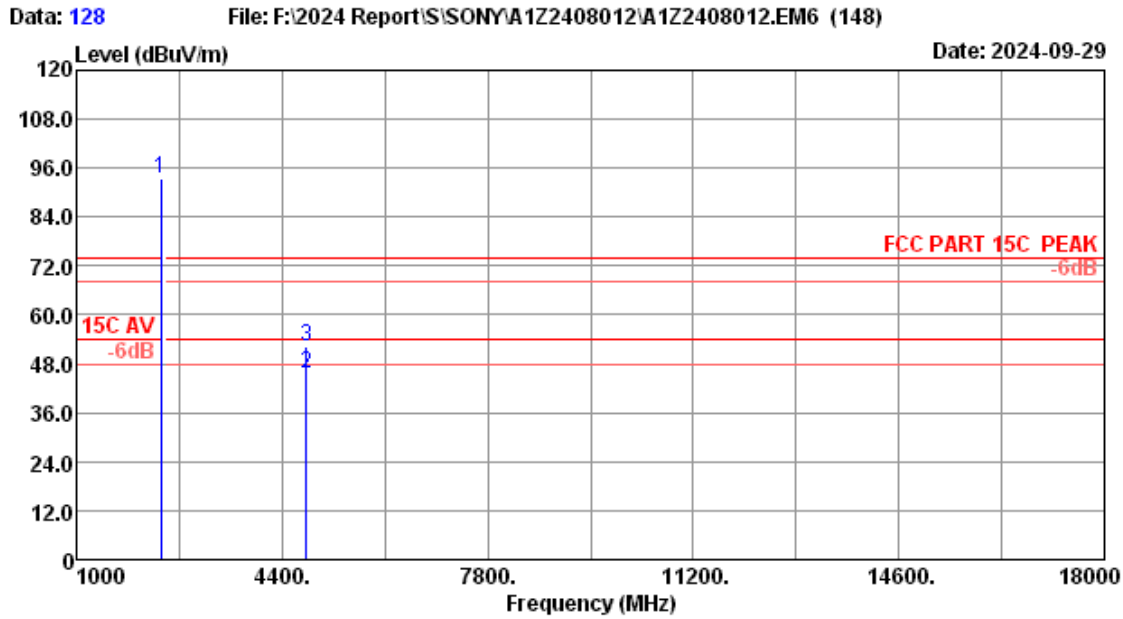

Site no. : 3m Chamber Data no. : 128
 Dis. / Ant. : 3m 2022 3115-4580 Ant. pol. : VERTICAL
 Limit : FCC PART 15C PEAK
 Env. / Ins. : 21.8°C/53.9% Engineer : epoch
 Test Mode : 2.4G 2403MHz ANTA TX Mode

No.	Freq. (MHz)	Ant. Factor (dB/m)	Cable Loss (dB)	Reading (dBUV)	Amp factor (dB)	Emission Level (dBUV/m)	Limits (dBUV/m)	Margin (dB)	Remark
1	2403.00	28.11	5.32	91.69	31.70	93.42	-----	-----	Peak
2	4806.00	32.71	7.41	35.76	30.42	45.46	54.00	8.54	Average
3	4806.00	32.71	7.41	42.68	30.42	52.38	74.00	21.62	Peak

Remarks: 1. Emission Level= Antenna Factor + Cable Loss + Reading -Amp factor.
 2. The emission levels that are 20dB below the official limit are not reported.

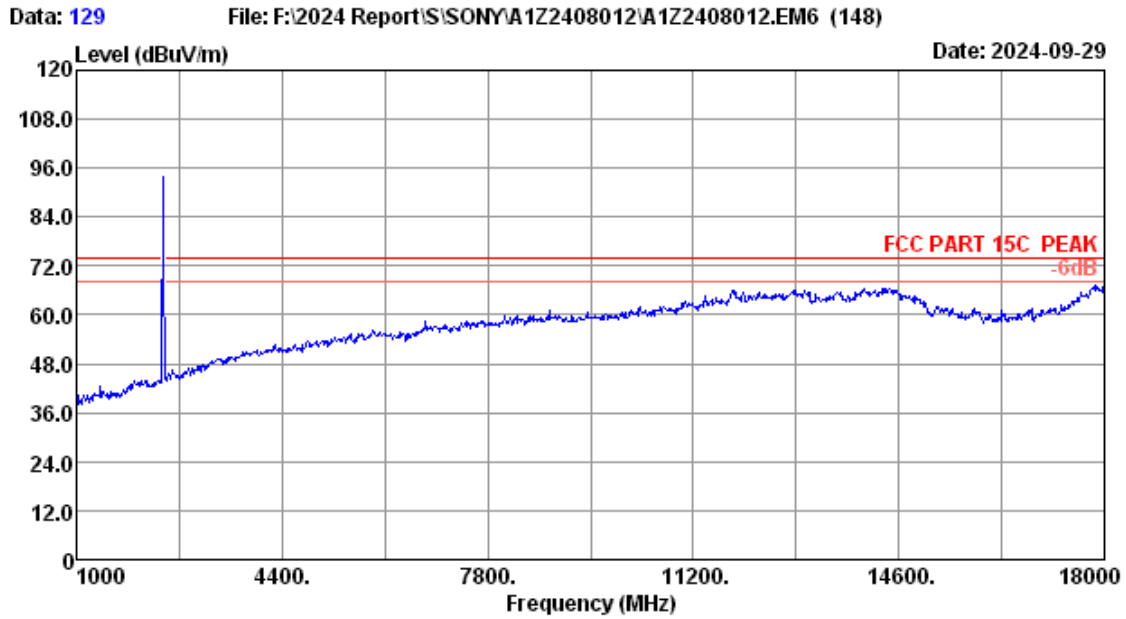

Site no.	: 3m Chamber	Data no.	: 129
Dis. / Ant.	: 3m 2022 3115-4580	Ant. pol.	: VERTICAL
Limit	: FCC PART 15C PEAK		
Env. / Ins.	: 21.8°C/53.9%	Engineer	: epoch
Test Mode	: 2.4G 2441MHz ANTÀ TX Mode		

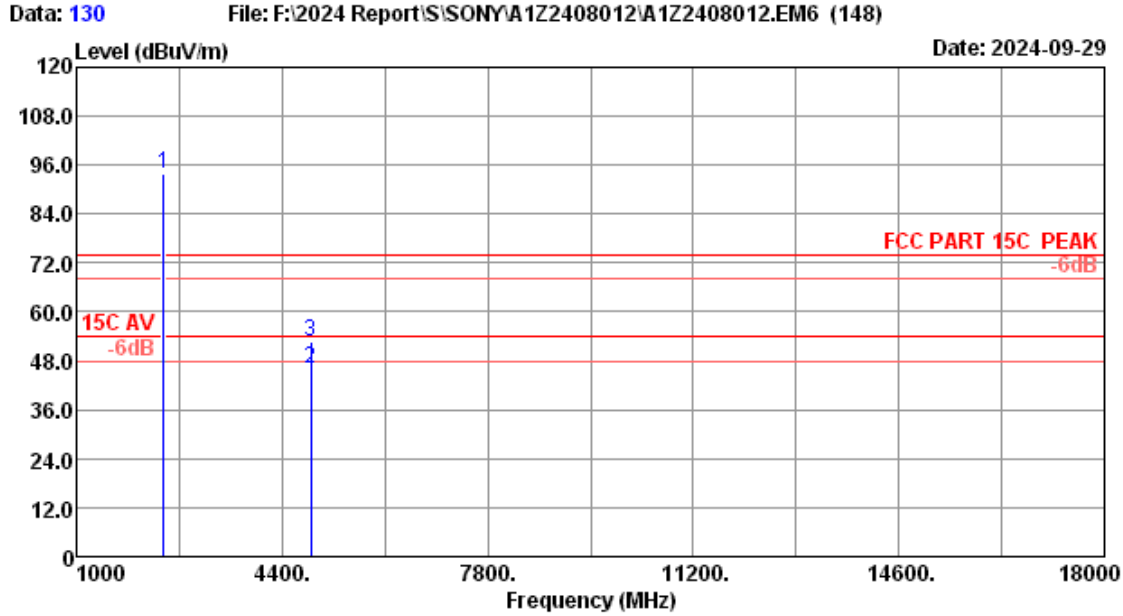

Site no. : 3m Chamber Data no. : 130
 Dis. / Ant. : 3m 2022 3115-4580 Ant. pol. : VERTICAL
 Limit : FCC PART 15C PEAK
 Env. / Ins. : 21.8°C/53.9% Engineer : epoch
 Test Mode : 2.4G 2441MHz ANTA TX Mode

No.	Freq. (MHz)	Ant. Factor (dB/m)	Cable Loss (dB)	Reading (dBUV)	Amp factor (dB)	Emission Level (dBUV/m)	Limits (dBUV/m)	Margin (dB)	Remark
1	2441.00	28.26	5.37	91.73	31.68	93.68	-----	-----	Peak
2	4882.00	32.86	7.45	36.27	30.41	46.17	54.00	7.83	Average
3	4882.00	32.86	7.45	42.72	30.41	52.62	74.00	21.38	Peak

Remarks: 1. Emission Level= Antenna Factor + Cable Loss + Reading -Amp factor.
 2. The emission levels that are 20dB below the official limit are not reported.

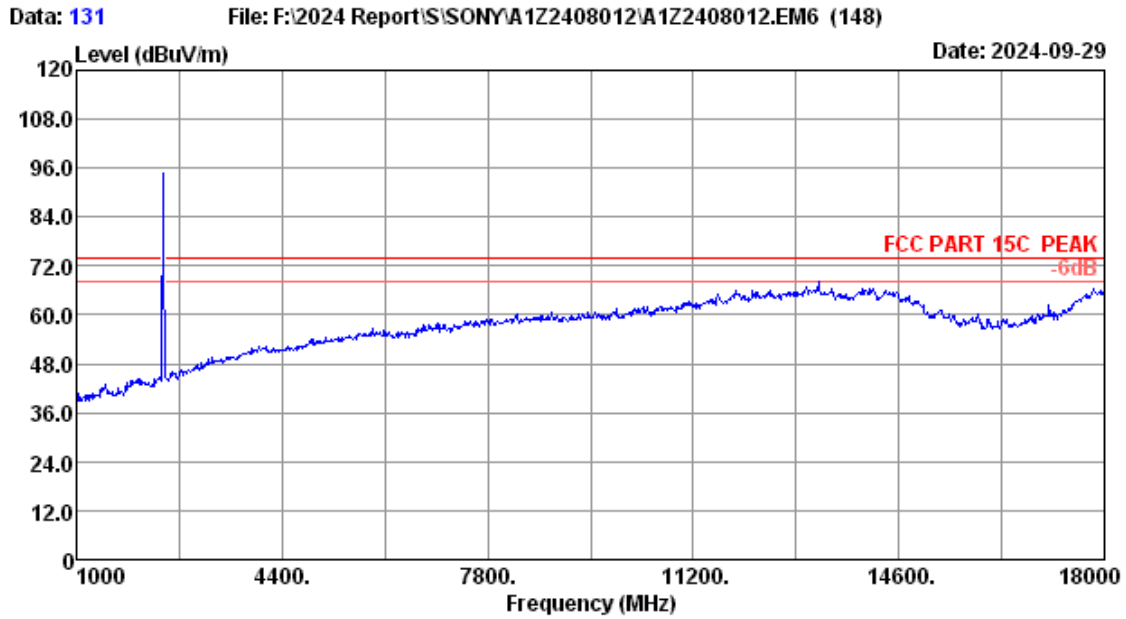

Site no.	: 3m Chamber	Data no.	: 131
Dis. / Ant.	: 3m 2022 3115-4580	Ant. pol.	: HORIZONTAL
Limit	: FCC PART 15C PEAK		
Env. / Ins.	: 21.8°C/53.9%	Engineer	: epoch
Test Mode	: 2.4G 2441MHz ANTÀ TX Mode		

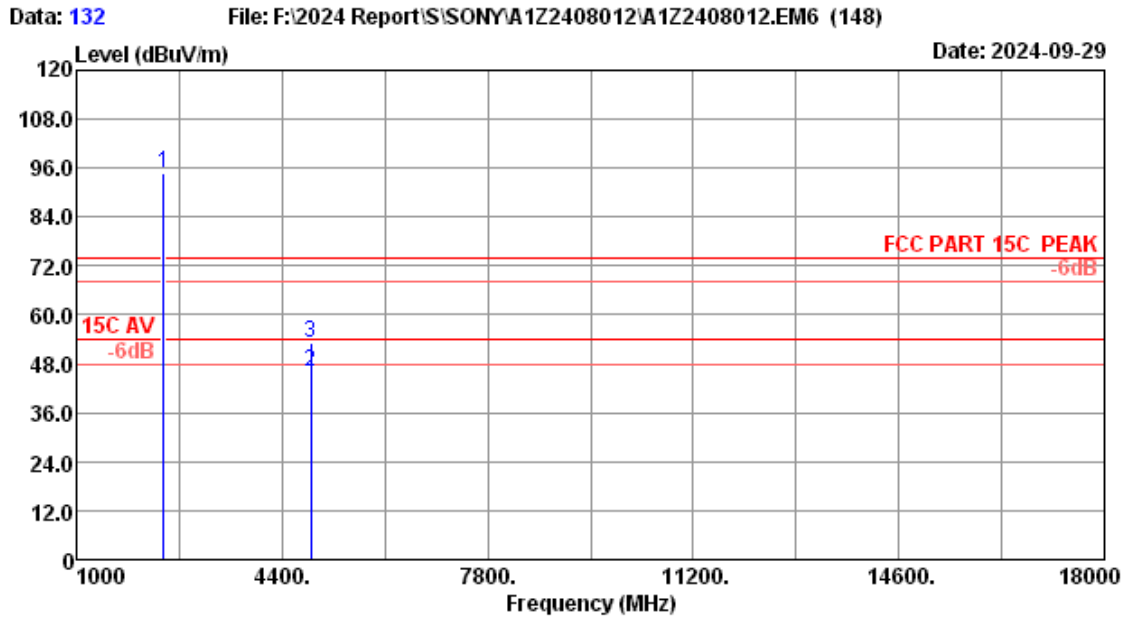

Site no. : 3m Chamber Data no. : 132
 Dis. / Ant. : 3m 2022 3115-4580 Ant. pol. : HORIZONTAL
 Limit : FCC PART 15C PEAK
 Env. / Ins. : 21.8°C/53.9% Engineer : epoch
 Test Mode : 2.4G 2441MHz ANTA TX Mode

No.	Freq. (MHz)	Ant. Factor (dB/m)	Cable Loss (dB)	Reading (dBuV)	Amp factor (dB)	Emission Level (dBuV/m)	Limits (dBuV/m)	Margin (dB)	Remark
1	2441.00	28.26	5.37	92.71	31.68	94.66	-----	-----	Peak
2	4882.00	32.86	7.45	36.18	30.41	46.08	54.00	7.92	Average
3	4882.00	32.86	7.45	43.42	30.41	53.32	74.00	20.68	Peak

Remarks: 1. Emission Level= Antenna Factor + Cable Loss + Reading -Amp factor.
 2. The emission levels that are 20dB below the official limit are not reported.

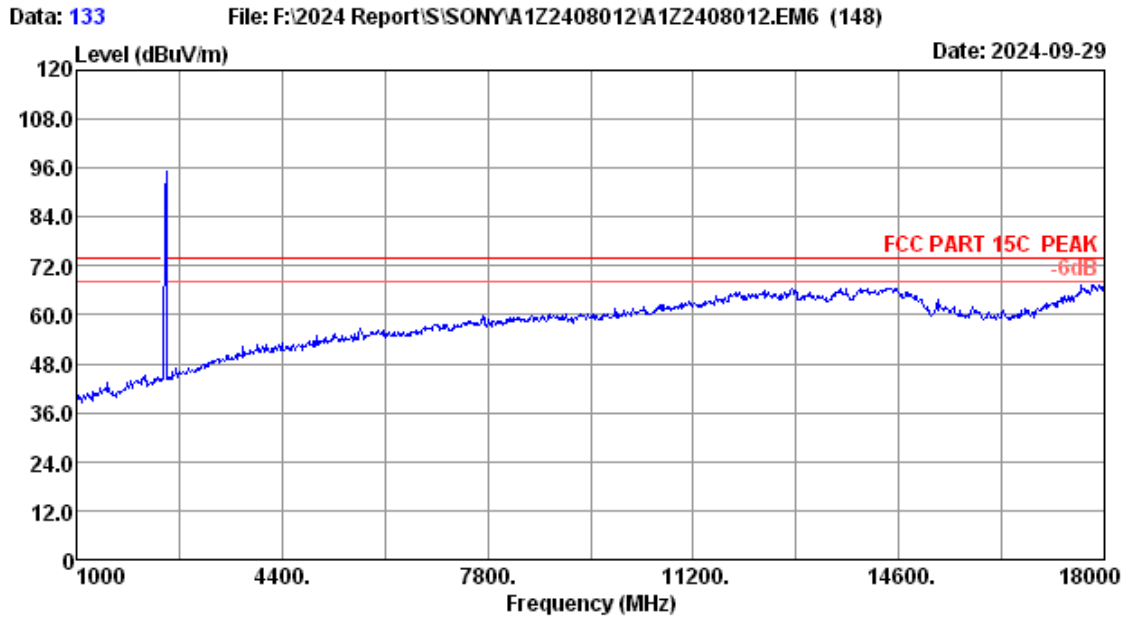

Site no.	: 3m Chamber	Data no.	: 133
Dis. / Ant.	: 3m 2022 3115-4580	Ant. pol.	: HORIZONTAL
Limit	: FCC PART 15C PEAK		
Env. / Ins.	: 21.8°C/53.9%	Engineer	: epoch
Test Mode	: 2.4G 2479MHz ANTÀ TX Mode		

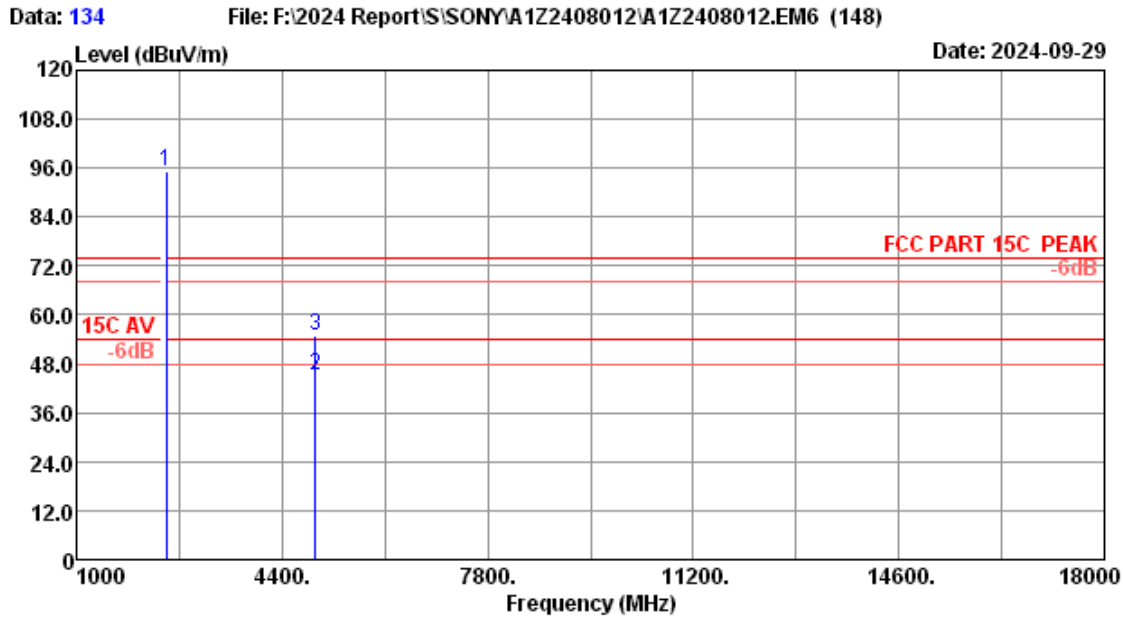

Site no. : 3m Chamber Data no. : 134
 Dis. / Ant. : 3m 2022 3115-4580 Ant. pol. : HORIZONTAL
 Limit : FCC PART 15C PEAK
 Env. / Ins. : 21.8°C/53.9% Engineer : epoch
 Test Mode : 2.4G 2479MHz ANTA TX Mode

No.	Freq. (MHz)	Ant. Factor (dB/m)	Cable Loss (dB)	Reading (dBUV)	Amp factor (dB)	Emission Level (dBUV/m)	Limits (dBUV/m)	Margin (dB)	Remark
1	2479.00	28.30	5.41	93.25	31.66	95.30	-----	-----	Peak
2	4958.00	33.02	7.50	35.25	30.40	45.37	54.00	8.63	Average
3	4958.00	33.02	7.50	44.59	30.40	54.71	74.00	19.29	Peak

Remarks: 1. Emission Level= Antenna Factor + Cable Loss + Reading -Amp factor.
 2. The emission levels that are 20dB below the official limit are not reported.

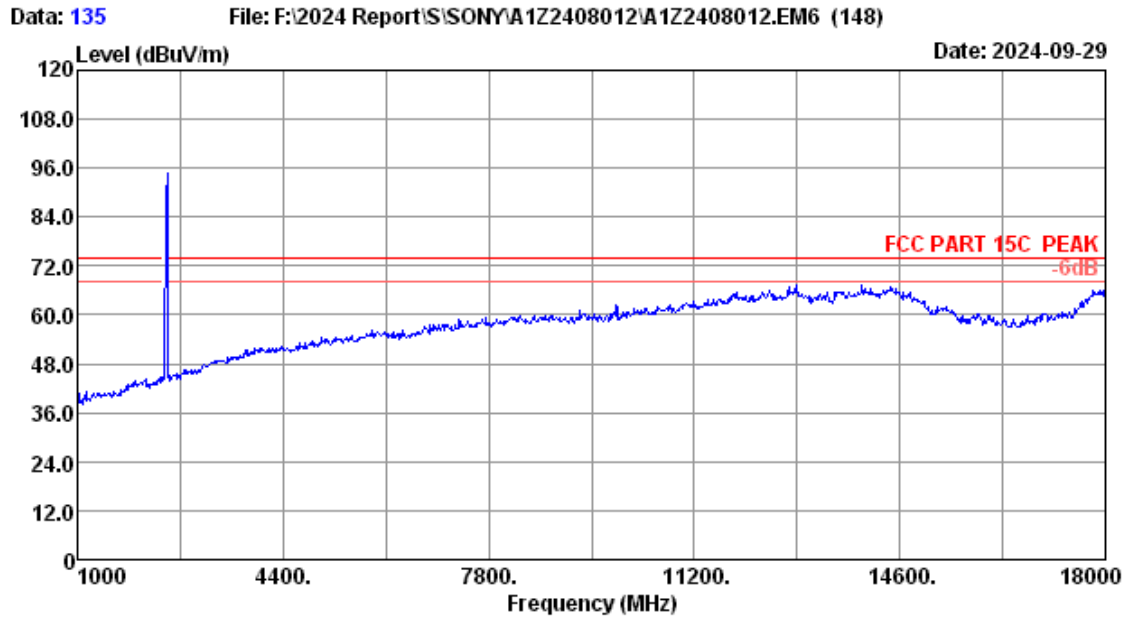

Site no.	: 3m Chamber	Data no.	: 135
Dis. / Ant.	: 3m 2022 3115-4580	Ant. pol.	: VERTICAL
Limit	: FCC PART 15C PEAK		
Env. / Ins.	: 21.8°C/53.9%	Engineer	: epoch
Test Mode	: 2.4G 2479MHz ANTÀ TX Mode		

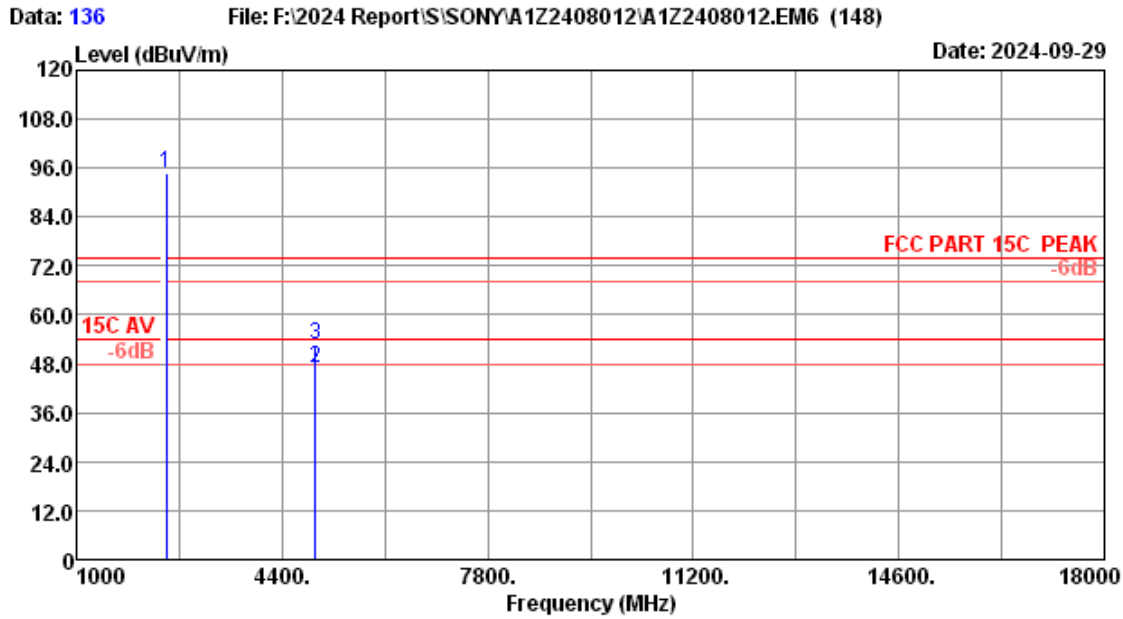

Site no. : 3m Chamber Data no. : 136
 Dis. / Ant. : 3m 2022 3115-4580 Ant. pol. : VERTICAL
 Limit : FCC PART 15C PEAK
 Env. / Ins. : 21.8°C/53.9% Engineer : epoch
 Test Mode : 2.4G 2479MHz ANTA TX Mode

No.	Freq. (MHz)	Ant. Factor (dB/m)	Cable Loss (dB)	Reading (dBuV)	Amp factor (dB)	Emission Level (dBuV/m)	Limits (dBuV/m)	Margin (dB)	Remark
1	2479.00	28.30	5.41	92.82	31.66	94.87	-----	-----	Peak
2	4958.00	33.02	7.50	36.76	30.40	46.88	54.00	7.12	Average
3	4958.00	33.02	7.50	42.67	30.40	52.79	74.00	21.21	Peak

Remarks: 1. Emission Level= Antenna Factor + Cable Loss + Reading -Amp factor.
 2. The emission levels that are 20dB below the official limit are not reported.

ANT B

Data: 137

File: F:\2024 Report\SONYA1Z2408012\A1Z2408012.EM6 (148)

Date: 2024-09-30

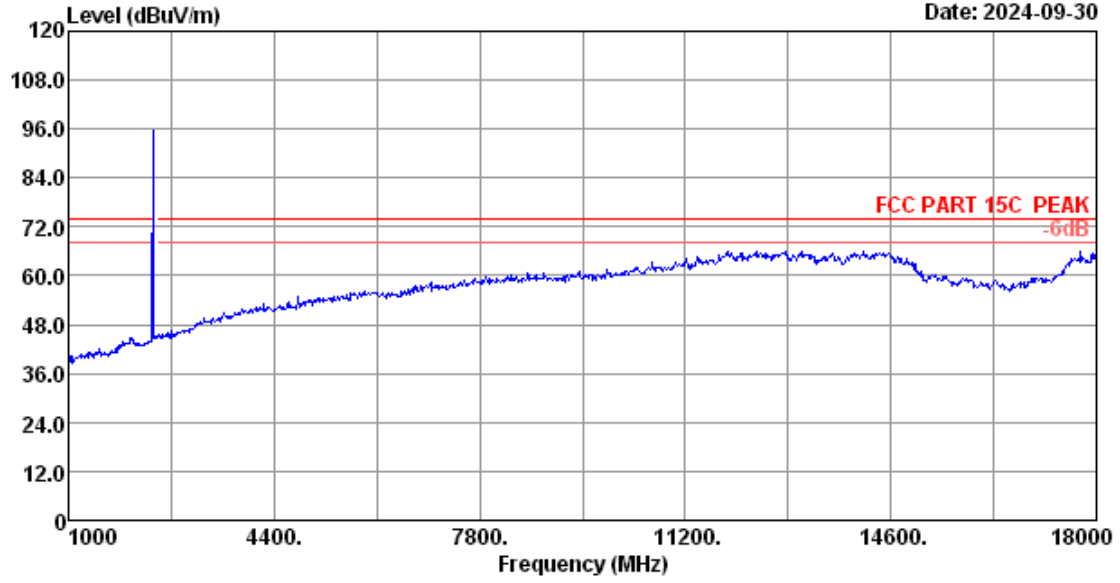

Site no.	: 3m Chamber	Data no.	: 137
Dis. / Ant.	: 3m 2022 3115-4580	Ant. pol.	: VERTICAL
Limit	: FCC PART 15C PEAK		
Env. / Ins.	: 21.8°C/53.9%	Engineer	: epoch
Test Mode	: 2.4G 2403MHz ANTB TX Mode		

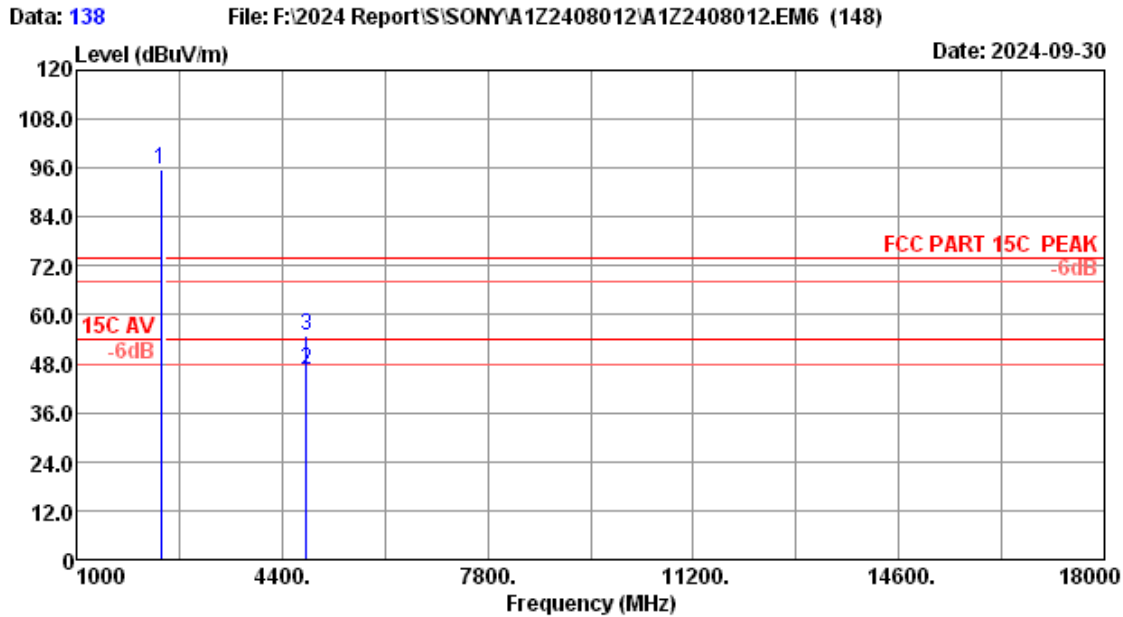

Site no. : 3m Chamber Data no. : 138
 Dis. / Ant. : 3m 2022 3115-4580 Ant. pol. : VERTICAL
 Limit : FCC PART 15C PEAK
 Env. / Ins. : 21.8°C/53.9% Engineer : epoch
 Test Mode : 2.4G 2403MHz ANTB TX Mode

No.	Freq. (MHz)	Ant. Factor (dB/m)	Cable Loss (dB)	Reading (dBUV)	Amp factor (dB)	Emission Level (dBUV/m)	Limits (dBUV/m)	Margin (dB)	Remark
1	2403.00	28.11	5.32	93.72	31.70	95.45	-----	-----	Peak
2	4806.00	32.71	7.41	36.59	30.42	46.29	54.00	7.71	Average
3	4806.00	32.71	7.41	45.01	30.42	54.71	74.00	19.29	Peak

Remarks: 1. Emission Level= Antenna Factor + Cable Loss + Reading -Amp factor.
 2. The emission levels that are 20dB below the official limit are not reported.

Data: 139

File: F:\2024 Report\SONYA1Z2408012\A1Z2408012.EM6 (148)

Date: 2024-09-30

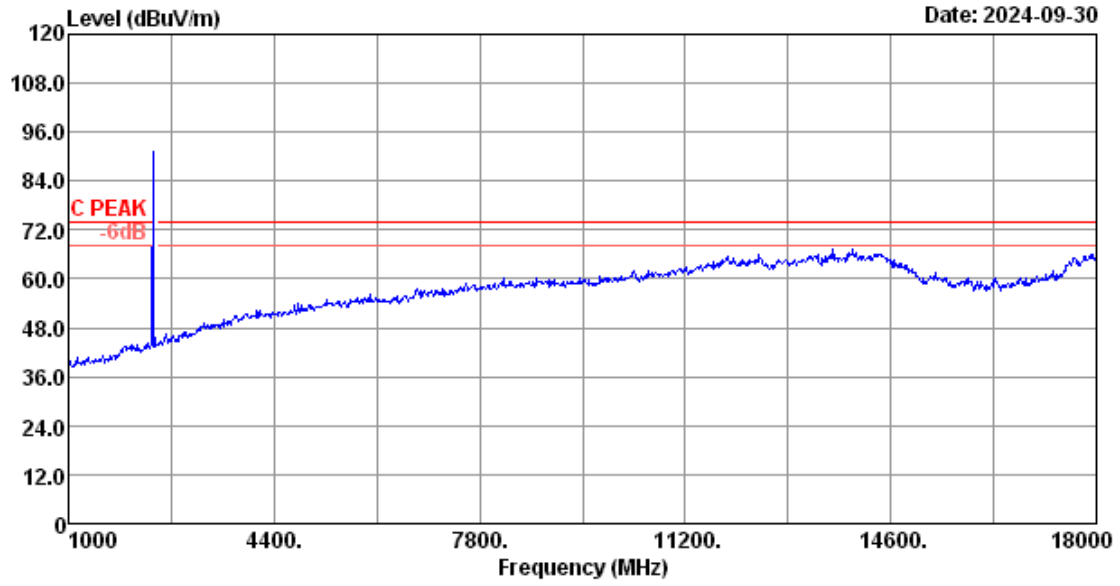

Site no.	: 3m Chamber	Data no.	: 139
Dis. / Ant.	: 3m 2022 3115-4580	Ant. pol.	: HORIZONTAL
Limit	: FCC PART 15C PEAK		
Env. / Ins.	: 21.8°C/53.9%	Engineer	: epoch
Test Mode	: 2.4G 2403MHz ANTB TX Mode		

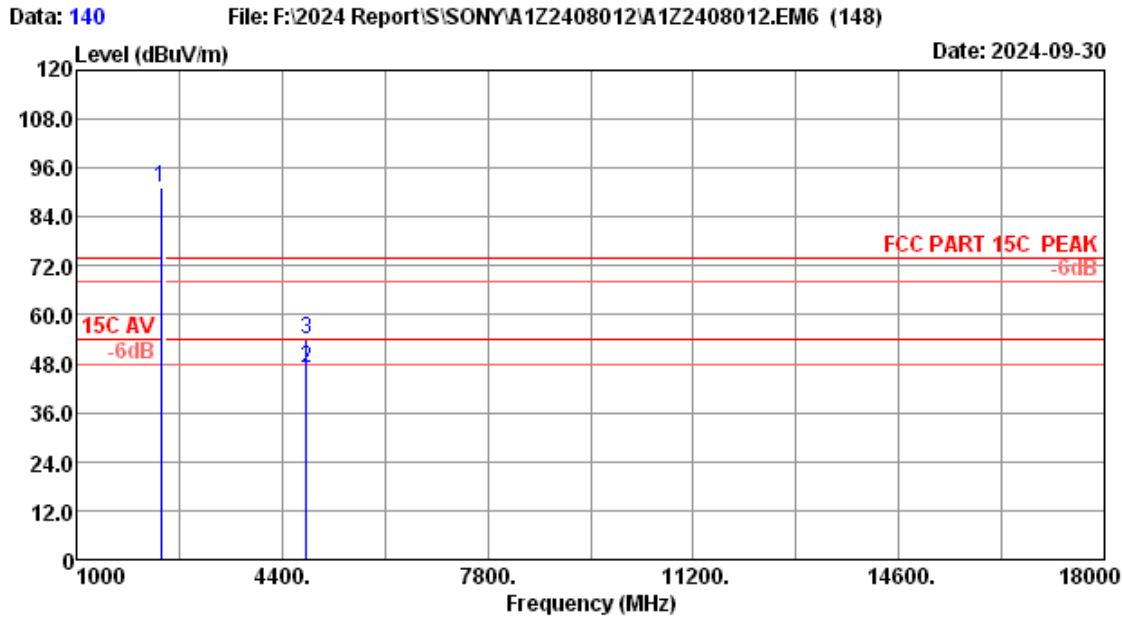

Site no. : 3m Chamber Data no. : 140
 Dis. / Ant. : 3m 2022 3115-4580 Ant. pol. : HORIZONTAL
 Limit : FCC PART 15C PEAK
 Env. / Ins. : 21.8°C/53.9% Engineer : epoch
 Test Mode : 2.4G 2403MHz ANTB TX Mode

No.	Freq. (MHz)	Ant. Factor (dB/m)	Cable Loss (dB)	Reading (dBUV)	Amp factor (dB)	Emission Level (dBUV/m)	Limits (dBUV/m)	Margin (dB)	Remark
1	2403.00	28.11	5.32	89.50	31.70	91.23	-----	-----	Peak
2	4806.00	32.71	7.41	37.02	30.42	46.72	54.00	7.28	Average
3	4806.00	32.71	7.41	44.37	30.42	54.07	74.00	19.93	Peak

Remarks: 1. Emission Level= Antenna Factor + Cable Loss + Reading -Amp factor.
 2. The emission levels that are 20dB below the official limit are not reported.

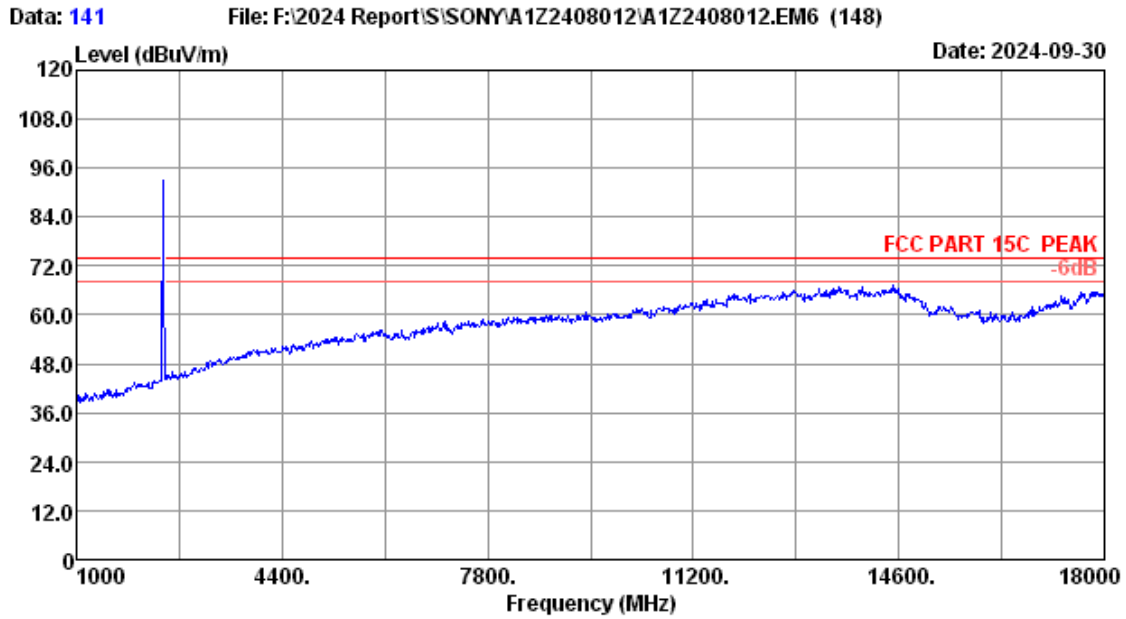

Site no.	: 3m Chamber	Data no.	: 141
Dis. / Ant.	: 3m 2022 3115-4580	Ant. pol.	: HORIZONTAL
Limit	: FCC PART 15C PEAK		
Env. / Ins.	: 21.8°C/53.9%	Engineer	: epoch
Test Mode	: 2.4G 2441MHz ANTB TX Mode		

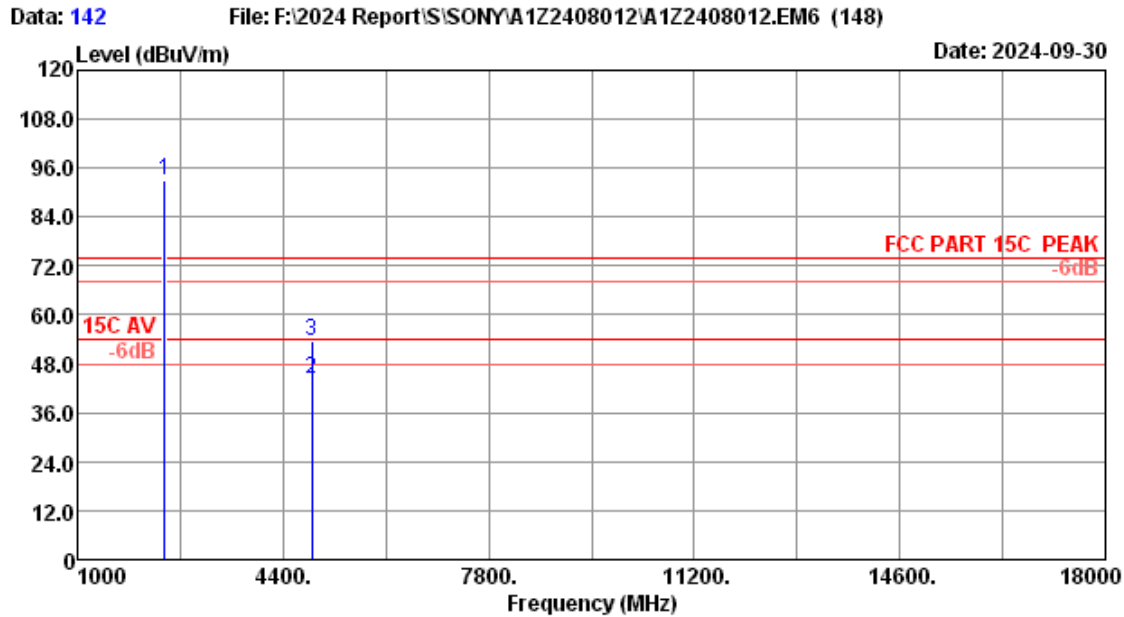

Site no. : 3m Chamber Data no. : 142
 Dis. / Ant. : 3m 2022 3115-4580 Ant. pol. : HORIZONTAL
 Limit : FCC PART 15C PEAK
 Env. / Ins. : 21.8°C/53.9% Engineer : epoch
 Test Mode : 2.4G 2441MHz ANTB TX Mode

No.	Freq. (MHz)	Ant. Factor (dB/m)	Cable Loss (dB)	Reading (dBUV)	Amp factor (dB)	Emission Level (dBUV/m)	Limits (dBUV/m)	Margin (dB)	Remark
1	2441.00	28.26	5.37	91.11	31.68	93.06	-----	-----	Peak
2	4882.00	32.86	7.45	34.28	30.41	44.18	54.00	9.82	Average
3	4882.00	32.86	7.45	43.49	30.41	53.39	74.00	20.61	Peak

Remarks: 1. Emission Level= Antenna Factor + Cable Loss + Reading -Amp factor.
 2. The emission levels that are 20dB below the official limit are not reported.

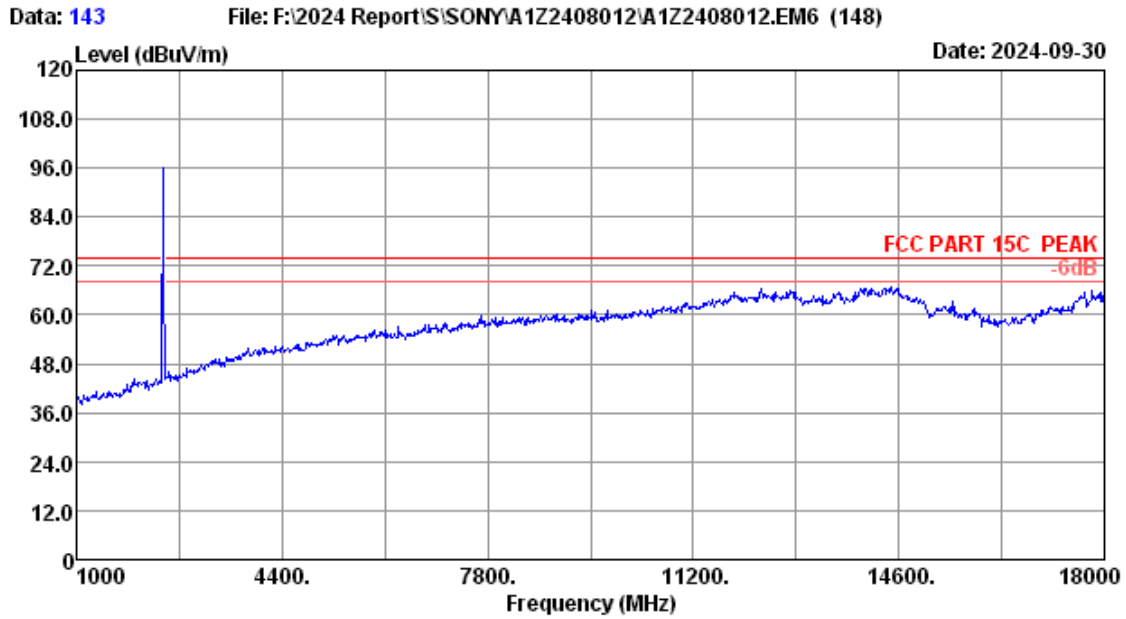

Site no.	: 3m Chamber	Data no.	: 143
Dis. / Ant.	: 3m 2022 3115-4580	Ant. pol.	: VERTICAL
Limit	: FCC PART 15C PEAK		
Env. / Ins.	: 21.8°C/53.9%	Engineer	: epoch
Test Mode	: 2.4G 2441MHz ANTB TX Mode		

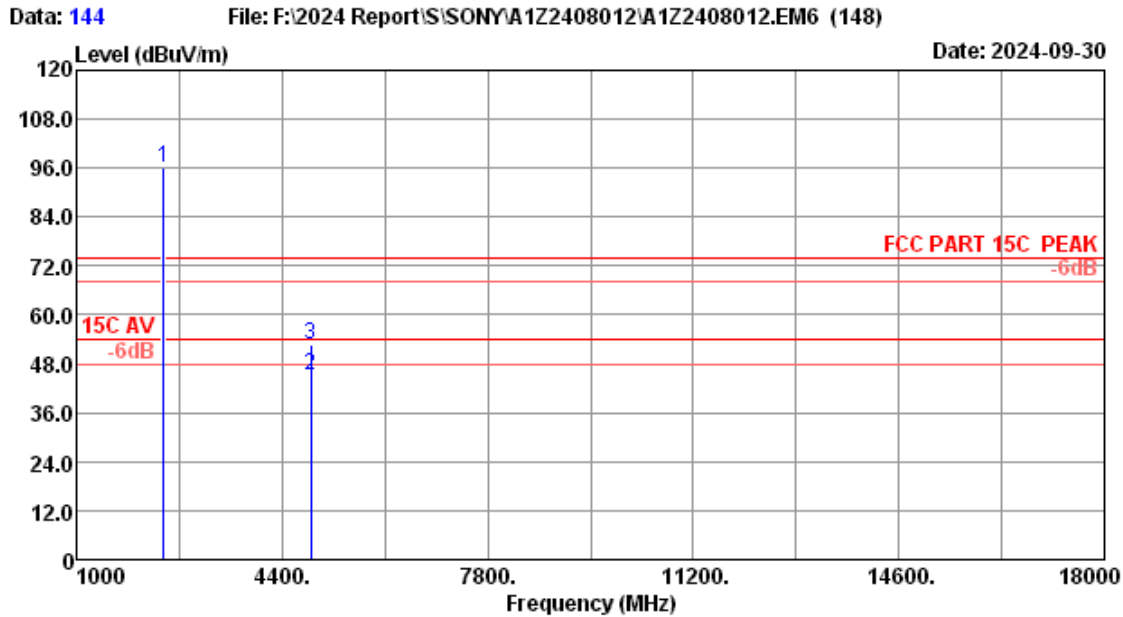

Site no. : 3m Chamber Data no. : 144
 Dis. / Ant. : 3m 2022 3115-4580 Ant. pol. : VERTICAL
 Limit : FCC PART 15C PEAK
 Env. / Ins. : 21.8°C/53.9% Engineer : epoch
 Test Mode : 2.4G 2441MHz ANTB TX Mode

No.	Freq. (MHz)	Ant. Factor (dB/m)	Cable Loss (dB)	Reading (dBUV)	Amp factor (dB)	Emission Level (dBUV/m)	Limits (dBUV/m)	Margin (dB)	Remark
1	2441.00	28.26	5.37	93.95	31.68	95.90	-----	-----	Peak
2	4882.00	32.86	7.45	35.29	30.41	45.19	54.00	8.81	Average
3	4882.00	32.86	7.45	42.86	30.41	52.76	74.00	21.24	Peak

Remarks: 1. Emission Level= Antenna Factor + Cable Loss + Reading -Amp factor.
 2. The emission levels that are 20dB below the official limit are not reported.

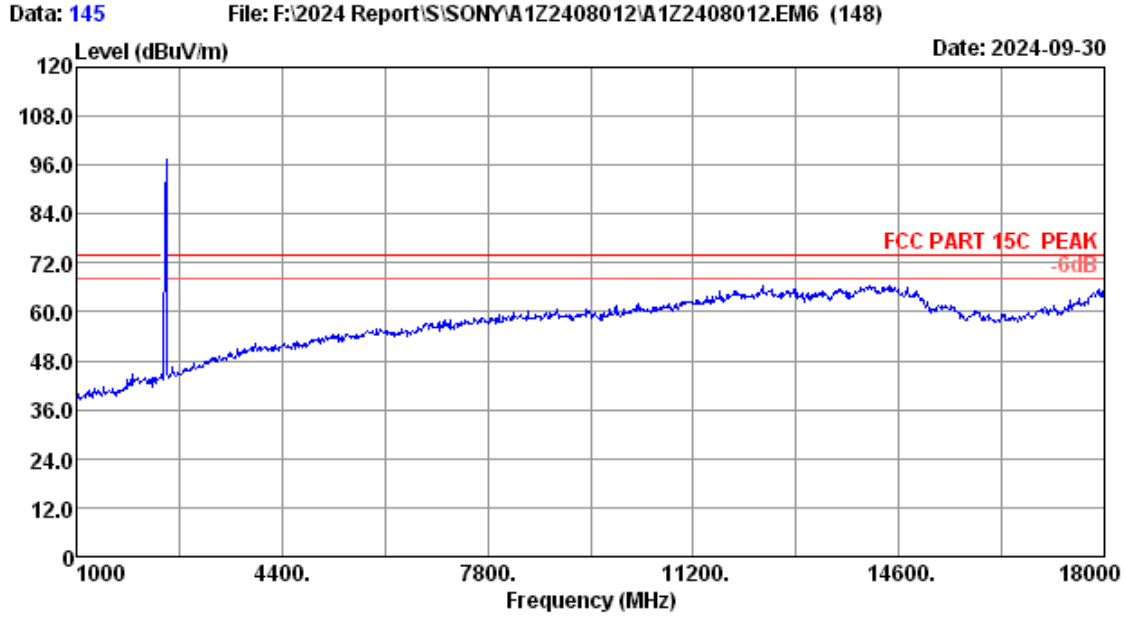

Site no.	: 3m Chamber	Data no.	: 145
Dis. / Ant.	: 3m 2022 3115-4580	Ant. pol.	: VERTICAL
Limit	: FCC PART 15C PEAK		
Env. / Ins.	: 21.8°C/53.9%	Engineer	: epoch
Test Mode	: 2.4G 2479MHz ANT B TX Mode		

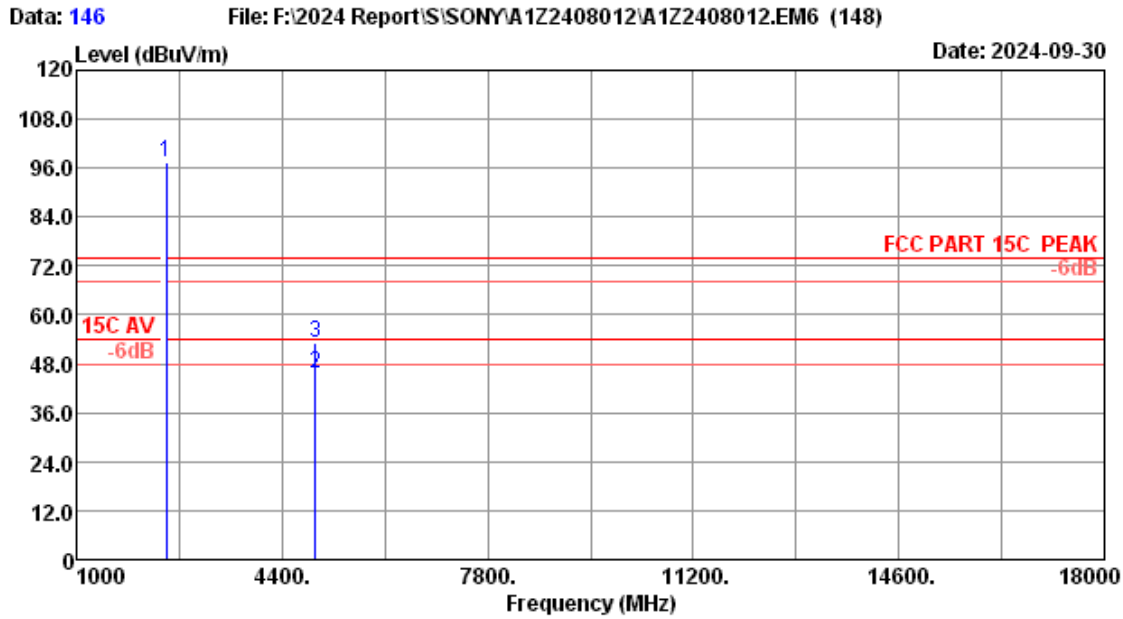

Site no. : 3m Chamber Data no. : 146
 Dis. / Ant. : 3m 2022 3115-4580 Ant. pol. : VERTICAL
 Limit : FCC PART 15C PEAK
 Env. / Ins. : 21.8°C/53.9% Engineer : epoch
 Test Mode : 2.4G 2479MHz ANTB TX Mode

No.	Freq. (MHz)	Ant. Factor (dB/m)	Cable Loss (dB)	Reading (dBUV)	Amp factor (dB)	Emission Level (dBUV/m)	Limits (dBUV/m)	Margin (dB)	Remark
1	2479.00	28.30	5.41	95.31	31.66	97.36	-----	-----	Peak
2	4958.00	33.02	7.50	35.68	30.40	45.80	54.00	8.20	Average
3	4958.00	33.02	7.50	42.93	30.40	53.05	74.00	20.95	Peak

Remarks: 1. Emission Level= Antenna Factor + Cable Loss + Reading -Amp factor.
 2. The emission levels that are 20dB below the official limit are not reported.

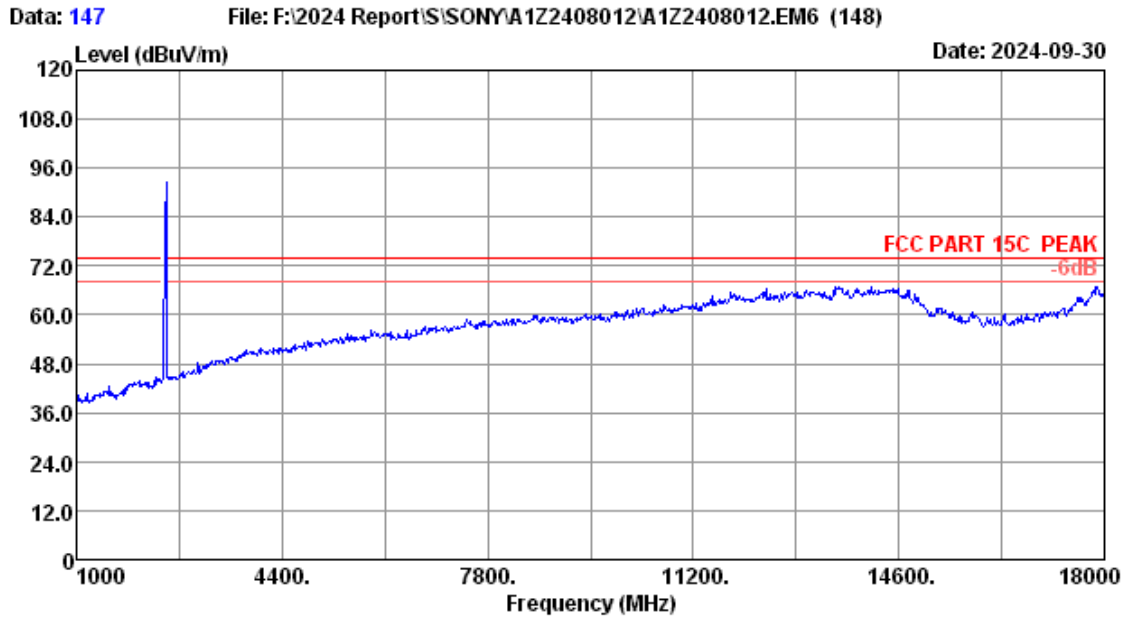

Site no.	: 3m Chamber	Data no.	: 147
Dis. / Ant.	: 3m 2022 3115-4580	Ant. pol.	: HORIZONTAL
Limit	: FCC PART 15C PEAK		
Env. / Ins.	: 21.8°C/53.9%	Engineer	: epoch
Test Mode	: 2.4G 2479MHz ANTB TX Mode		

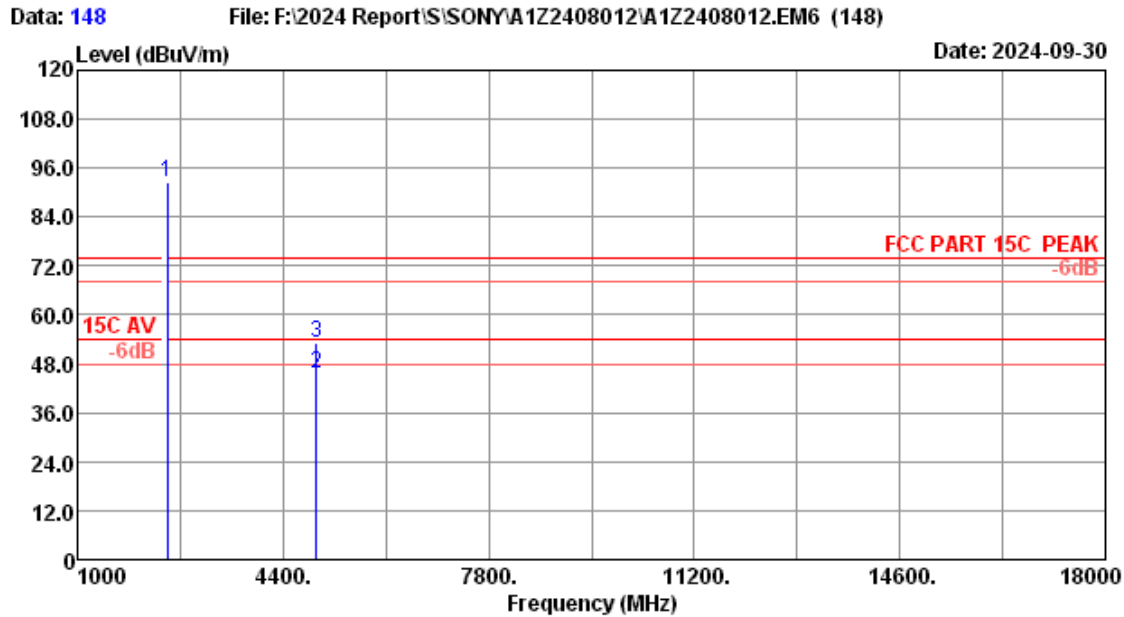

Site no. : 3m Chamber Data no. : 148
 Dis. / Ant. : 3m 2022 3115-4580 Ant. pol. : HORIZONTAL
 Limit : FCC PART 15C PEAK
 Env. / Ins. : 21.8°C/53.9% Engineer : epoch
 Test Mode : 2.4G 2479MHz ANTB TX Mode

No.	Freq. (MHz)	Ant. Factor (dB/m)	Cable Loss (dB)	Reading (dBuV)	Amp factor (dB)	Emission Level (dBuV/m)	Limits (dBuV/m)	Margin (dB)	Remark
1	2479.00	28.30	5.41	90.33	31.66	92.38	-----	-----	Peak
2	4958.00	33.02	7.50	35.68	30.40	45.80	54.00	8.20	Average
3	4958.00	33.02	7.50	42.81	30.40	52.93	74.00	21.07	Peak

Remarks: 1. Emission Level= Antenna Factor + Cable Loss + Reading -Amp factor.
 2. The emission levels that are 20dB below the official limit are not reported.

5. CONDUCTED SPURIOUS EMISSIONS

5.1. Test Equipment

Item	Equipment	Manufacturer	Model No.	Serial No.	Last Cal.	Cal. Interval
1.	PXA Signal Analyzer	Agilent	N9030A	MY51380221	Mar.16,24	1 Year
2.	RF Cable	Eastsheep	RM086-SMA/N-JJ-2000	NO.1	Jun.19,24	1 Year
3.	Attenuator(10dB)	Agilent	8491B	MY39269201	Mar.16,24	1 Year

5.2. Block Diagram of Test Setup



5.3. Limit

In any 100kHz bandwidth outside the frequency bands in which the spread spectrum intentional radiator is operating, the radio frequency power that is produced by the intentional radiator shall be at least 20dB below that in the 100kHz bandwidth within the band that contains the highest level of the desired power.

5.4. Test Procedure

Use the test method described in ANSI C63.10:

The transmitter output was connected to a spectrum analyzer, The resolution bandwidth is set to 100 kHz, The video bandwidth is set to 300 kHz and measure all the emissions with peak detector.

Note: The cable loss and attenuator loss were offset into spectrum analyzer as an amplitude offset.

5.5. Test result

PASS (The testing data was attached in the next pages.)

EUT: Active Subwoofer		
M/N: YY2088C2		
Test date: 2024-09-06~24	Pressure: 102.1±1.0 kpa	Humidity: 51.1±3.0%
Tested by: Lili	Test site: RF site	Temperature: 22.8±0.6 °C

ANT A

2403MHz

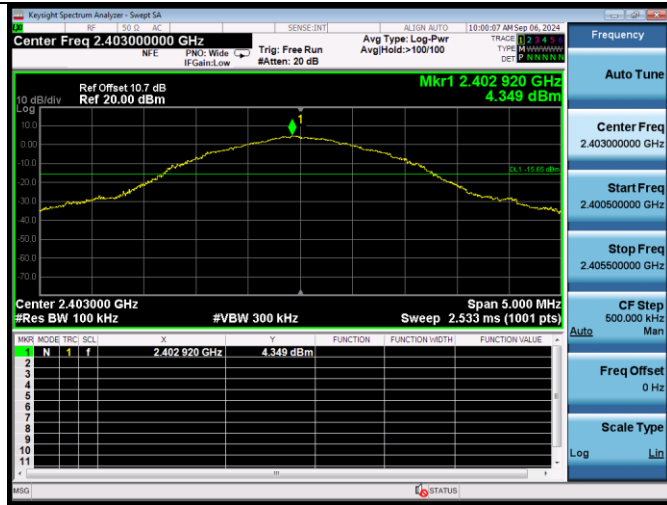

2403MHz(2.3GHz – 2.4GHz)

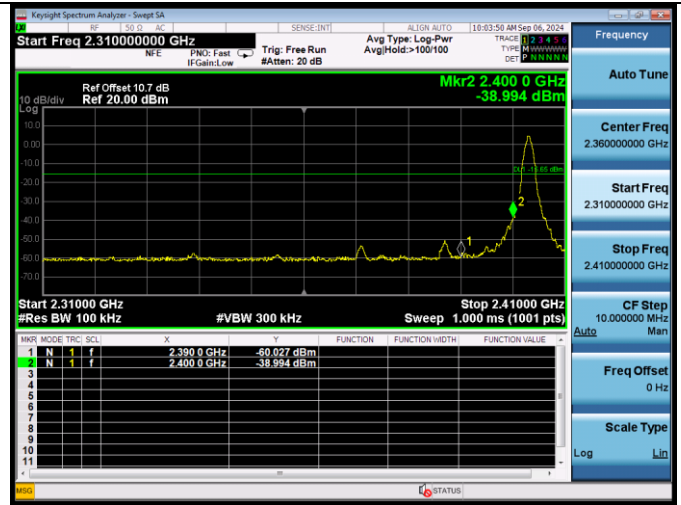

2403MHz(30MHz – 1GHz)

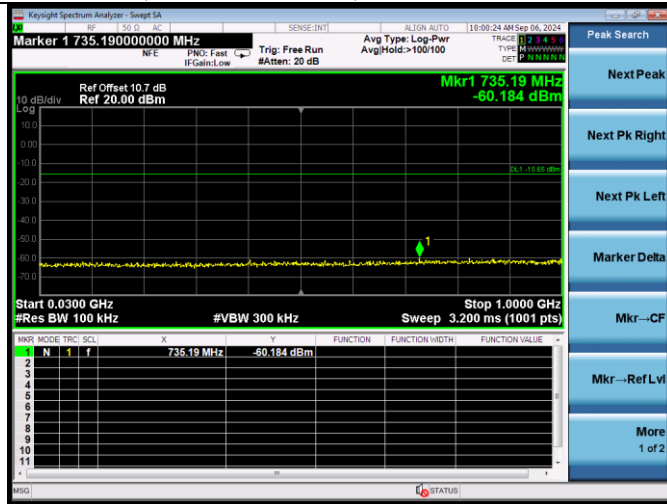

2403MHz(10GHz – 26GHz)

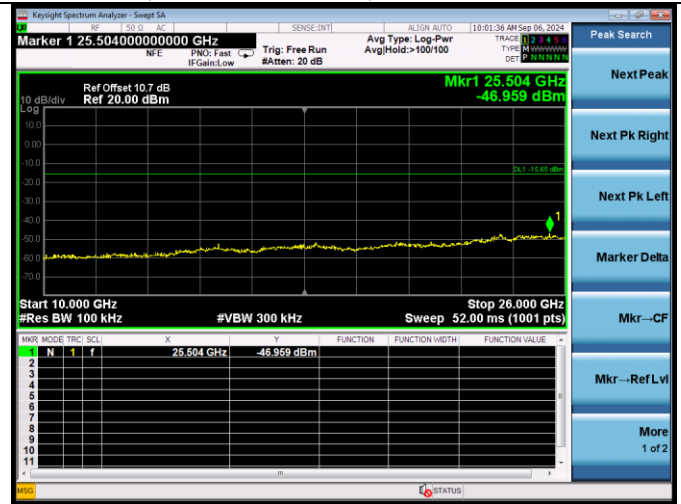

2403MHz(1GHz – 10GHz)

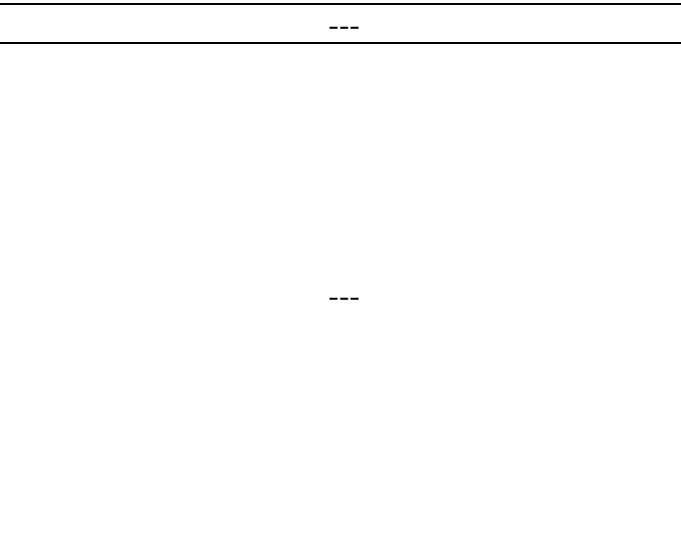
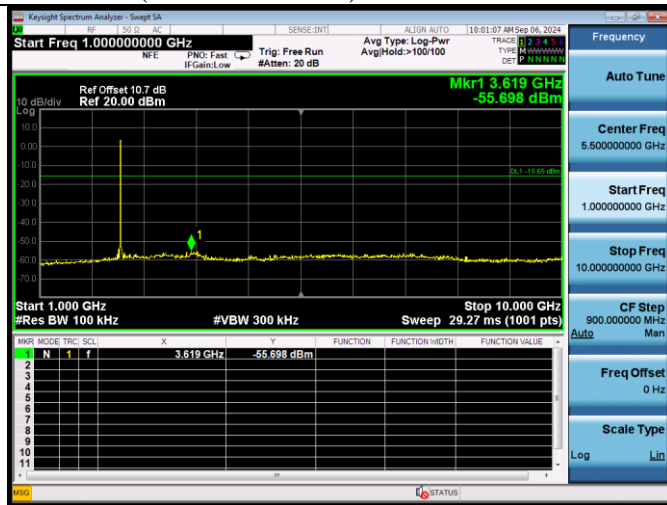

2441MHz

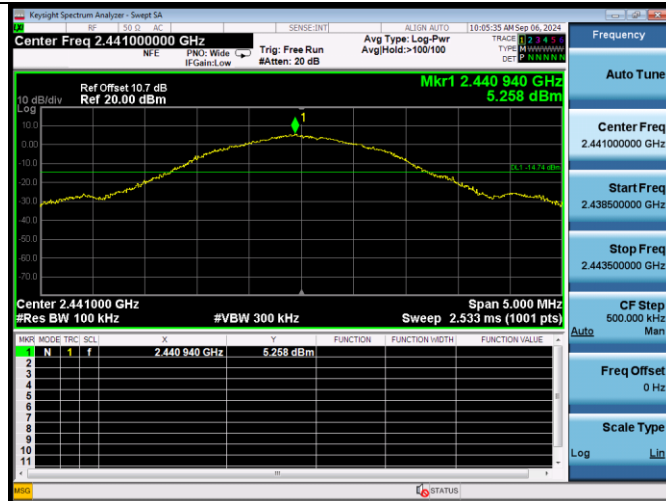

2441MHz(1GHz – 10GHz)

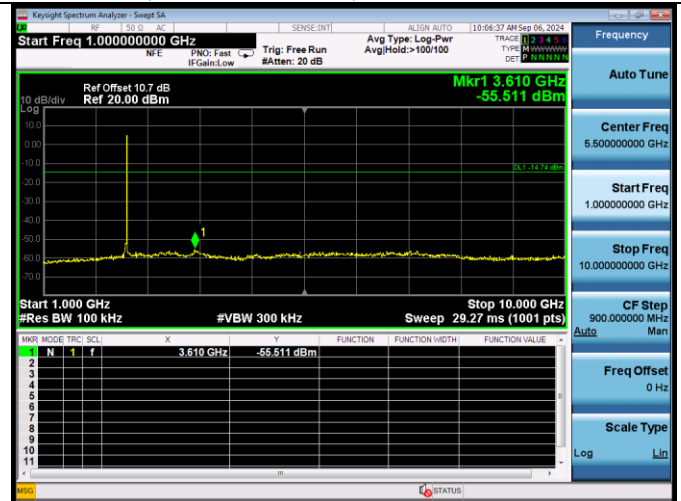

2441MHz(30MHz – 1GHz)

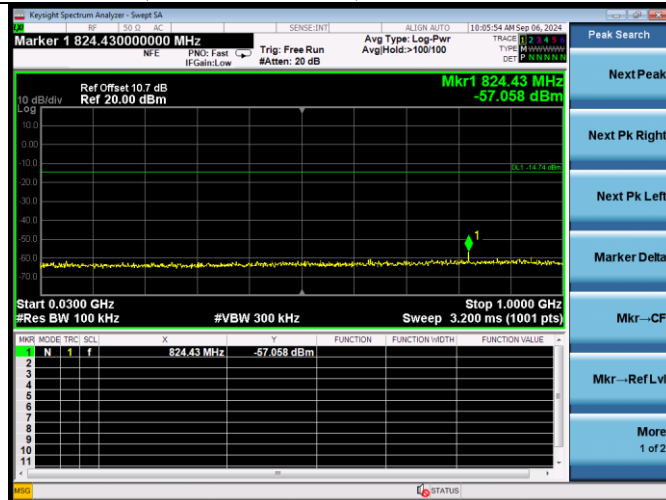

2441MHz(10GHz – 26GHz)

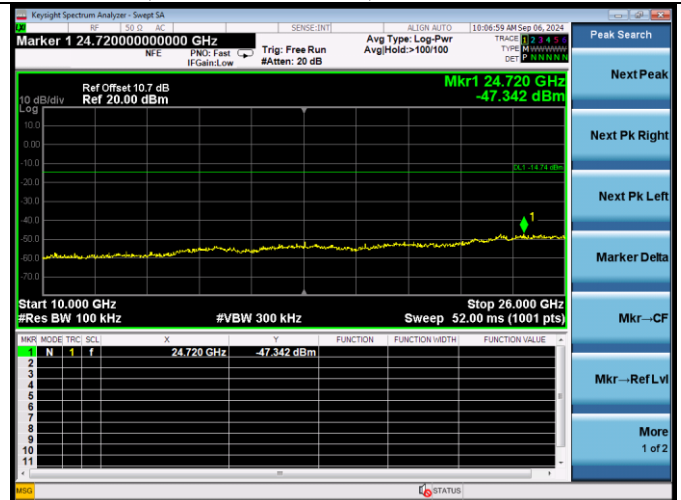

2479MHz

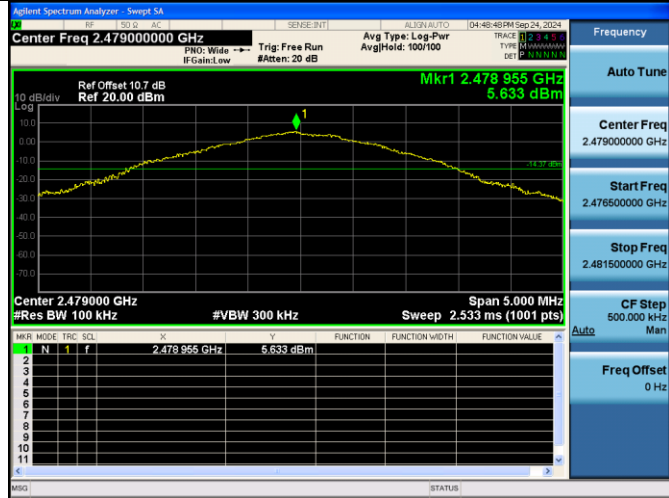

2479MHz(2.4GHz – 2.5GHz)

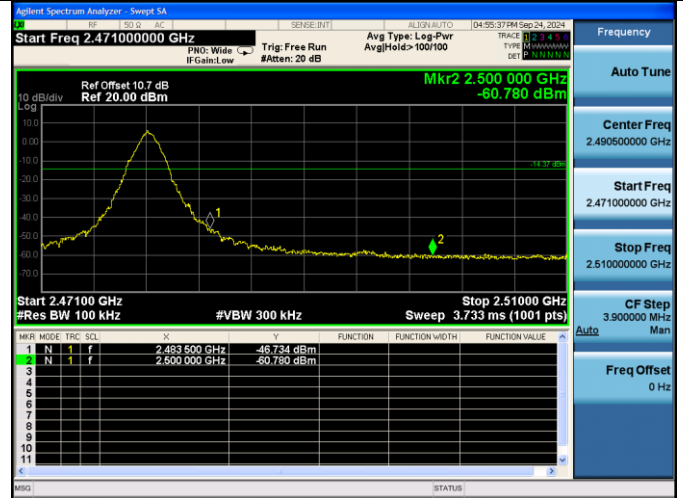

2479MHz(30MHz – 1GHz)

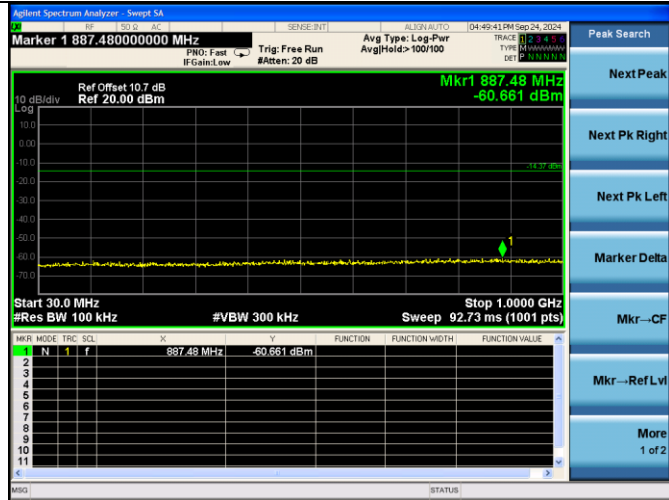

2479MHz(10GHz – 26GHz)

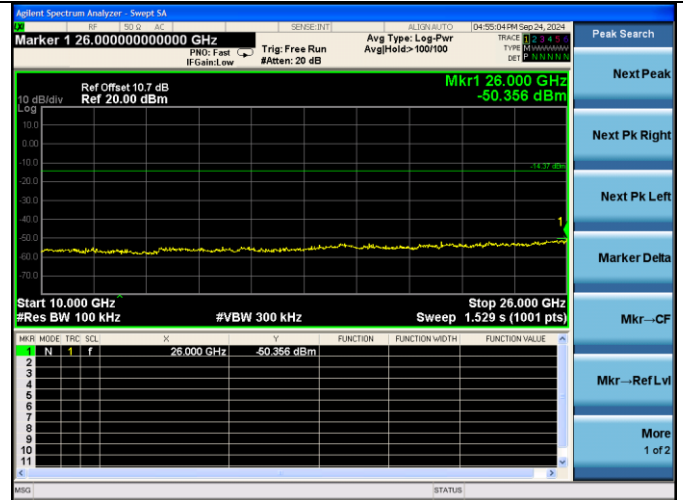

2479MHz(1GHz – 10GHz)

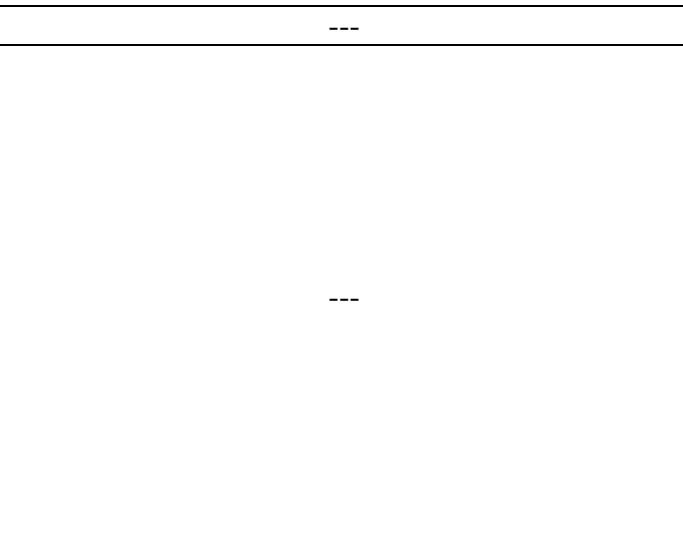
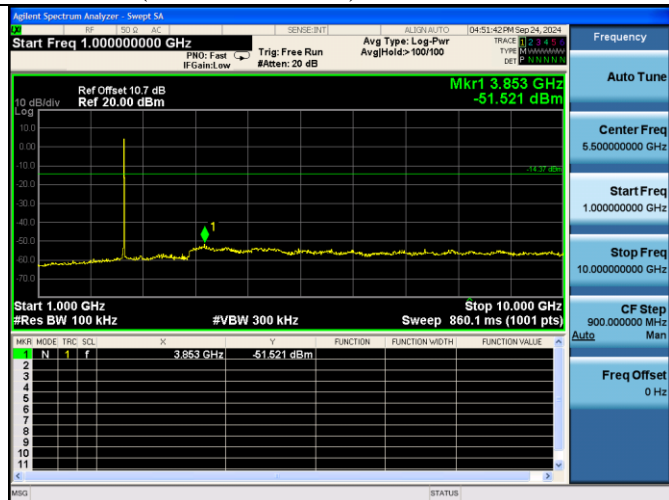

ANT B

2403MHz



2403MHz(2.3GHz – 2.4GHz)

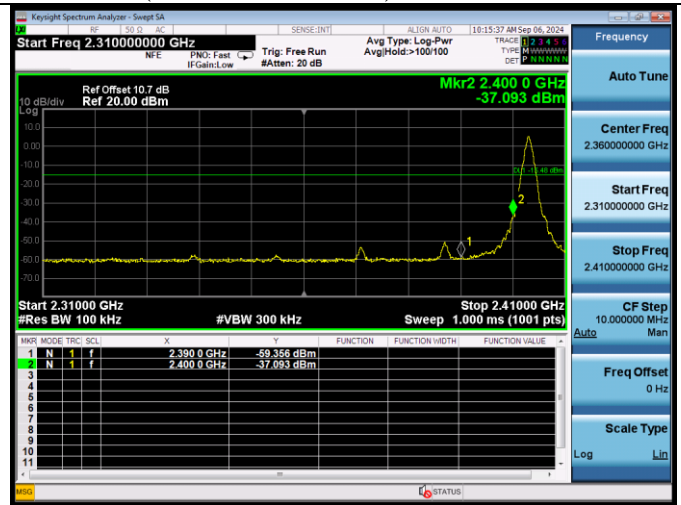

2403MHz(30MHz – 1GHz)

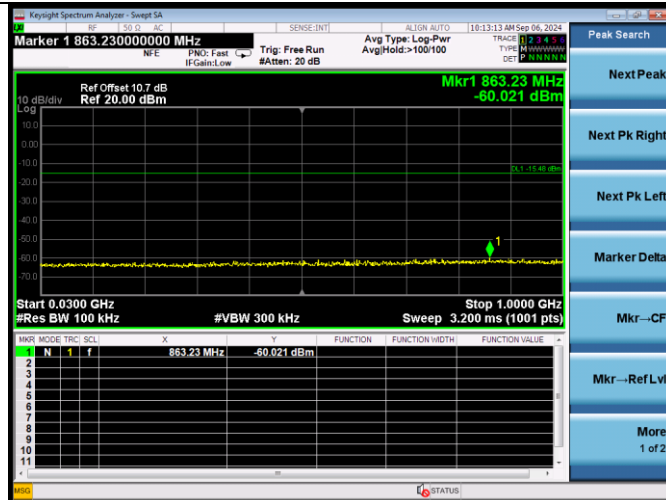

2403MHz(10GHz – 26GHz)

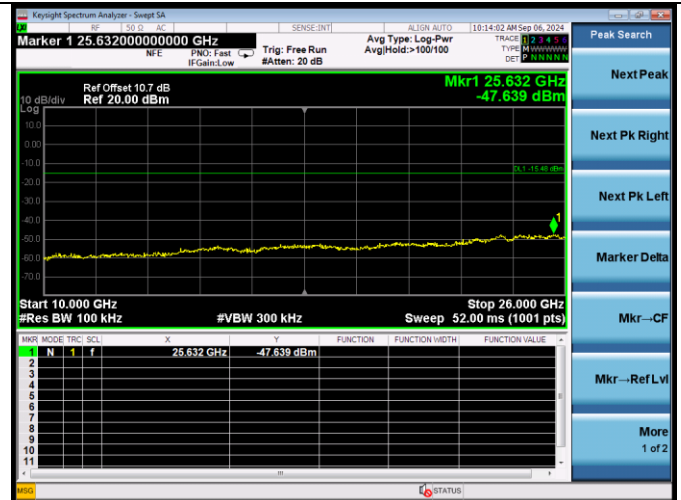

2403MHz(1GHz – 10GHz)

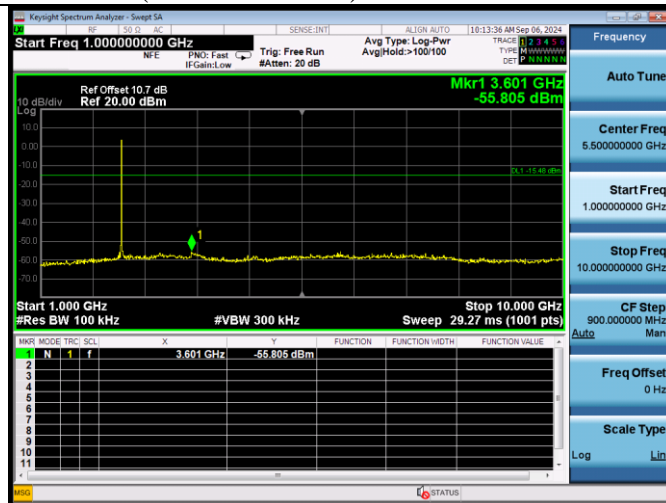

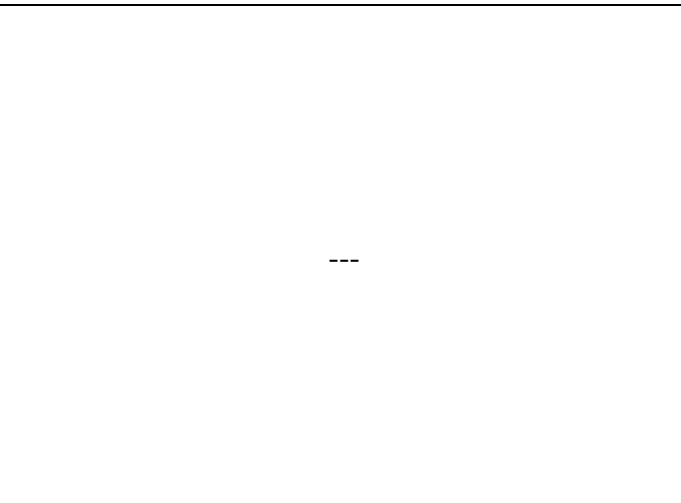

2441MHz

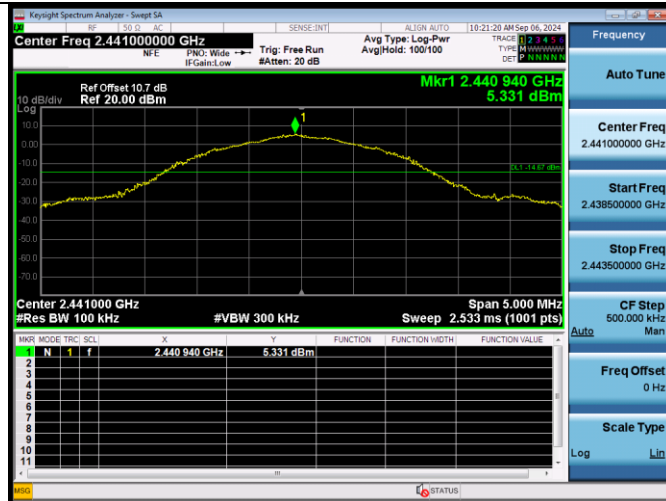

2441MHz(1GHz – 10GHz)

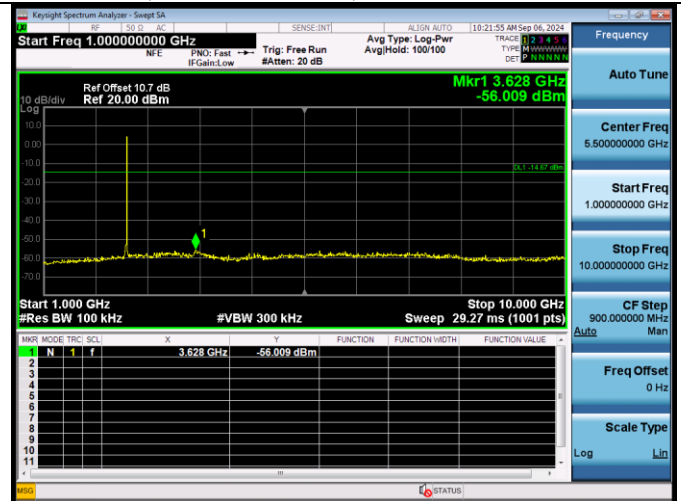

2441MHz(30MHz – 1GHz)

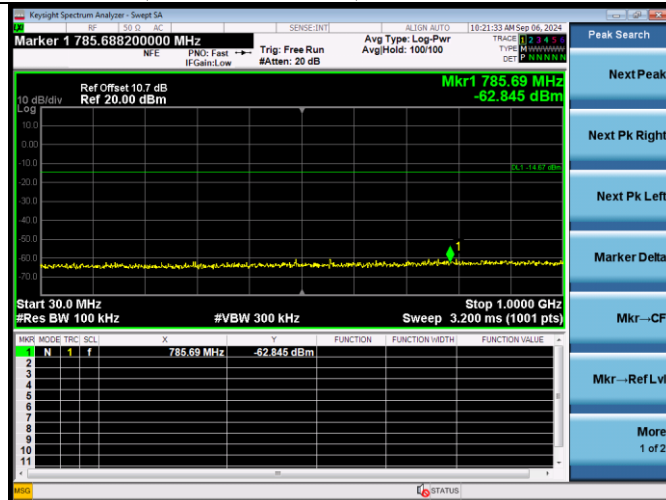

2441MHz(10GHz – 26GHz)

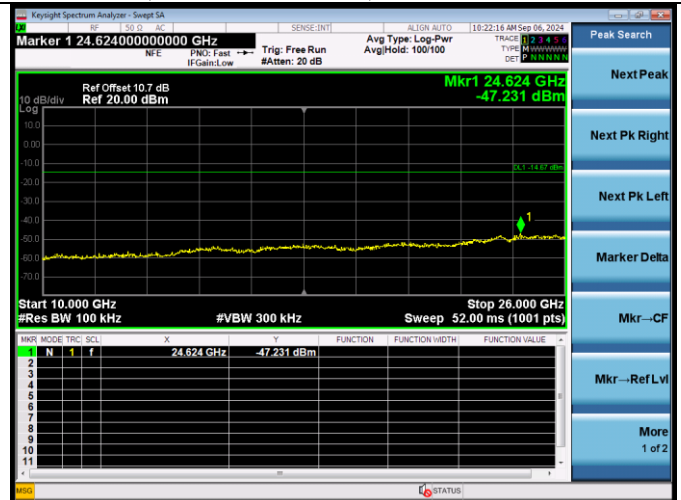

2479MHz

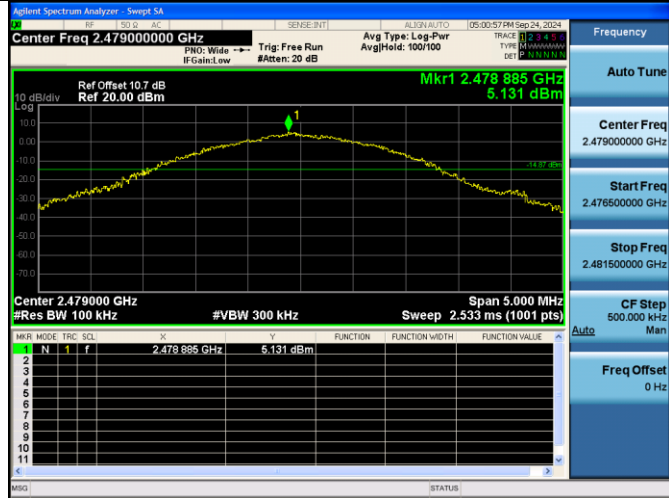

2479MHz(2.4GHz – 2.5GHz)

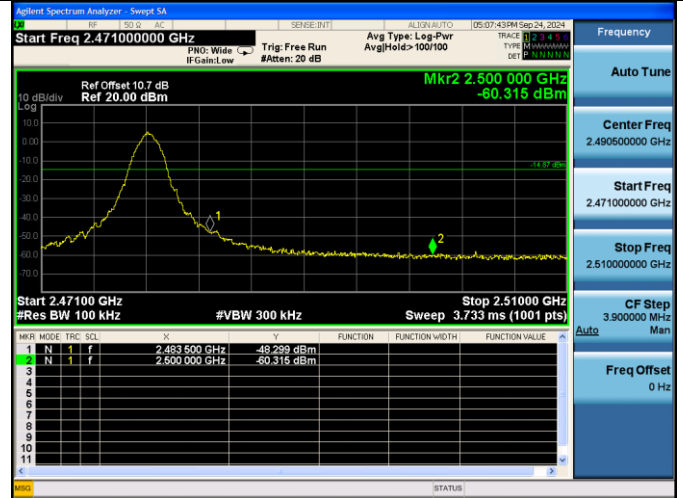

2479MHz(30MHz – 1GHz)

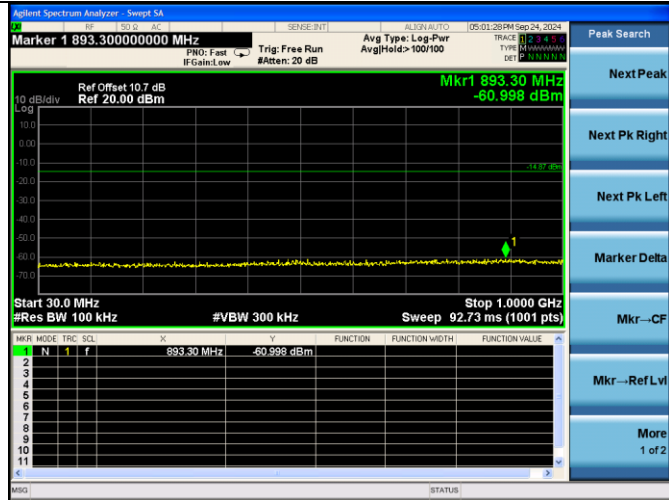

2479MHz(10GHz – 26GHz)

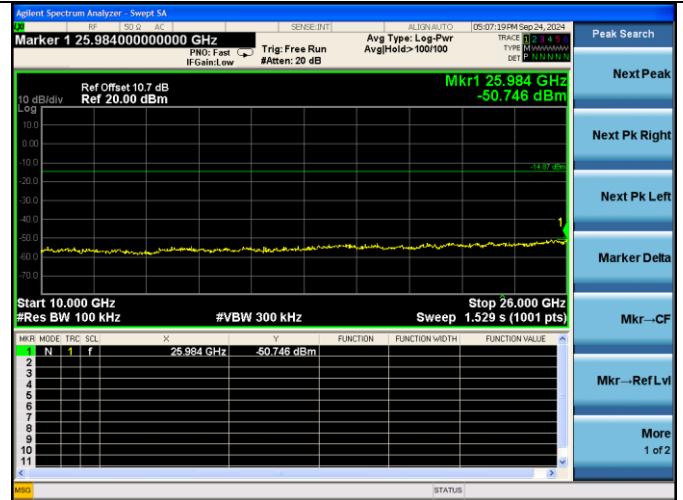

2479MHz(1GHz – 10GHz)

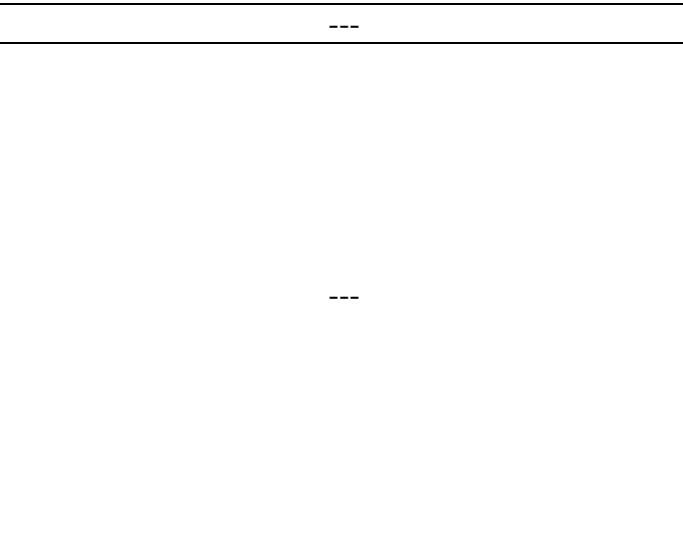
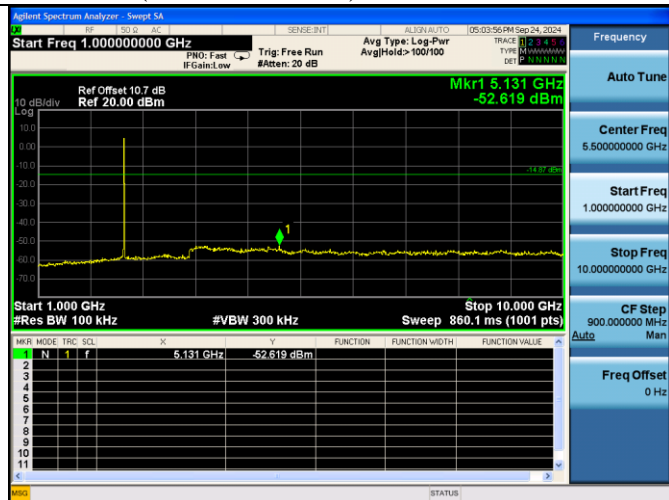

6. BAND EDGE COMPLIANCE TEST

6.1. Test Equipment

Item	Equipment	Manufacturer	Model No.	Serial No.	Last Cal.	Cal. Interval
1.	3m Chamber(NSA)	AUDIX	N/A	N/A	Aug.11,22	3Year
2.	3m Chamber(SE)	AUDIX	N/A	N/A	Sep.16,22	3 Year
3.	Signal Analyzer	Rohde & Schwarz	FSV40	101608	Nov.07,23	1 Year
4.	Amplifier	HP	8447D	2944A11159	Mar.17,24	1 Year
5.	RF Cable	TIMES MICROWAVE	SFT205-NMSM-10.00M	689241	Aug.13,24	1 Year
6.	Test Software	AUDIX	e3	6.100913a	N/A	N/A
7.	Horn Antenna	EMCO	3115	9510-4580	Jan.08,22	3 Year

Note: N/A means Not applicable.

6.2. Limit

All the lower and upper band-edges emissions appearing within 2310MHz to 2390MHz and 2483.5MHz to 2500MHz restricted frequency bands shall not exceed the limits shown in 15.209, all the other emissions outside operation frequency band 2400MHz to 2483.5MHz shall be at least 20dB below the fundamental emissions, or comply with 15.209 limits.

6.3. Test Procedure

1. The EUT is placed on a turntable, which is 0.8m above the ground plane and worked at highest radiated power.
2. The turntable was rotated for 360 degrees to determine the position of maximum emission level.
3. EUT is set 3m away from the receiving antenna, which is varied from 1m to 4m to find out the highest emission.
4. Set the spectrum analyzer in the following setting in order to capture the lower and upper band-edges of the emission:
 - (a) PEAK: RBW=1MHz ; VBW=3MHz, PK detector, Sweep=AUTO
 - (b) This device is pulse modulated, a duty cycle factor was used to calculate average level based measured peak level

6.4. Test Results

Pass (The testing data was attached in the next pages.)

ANT A

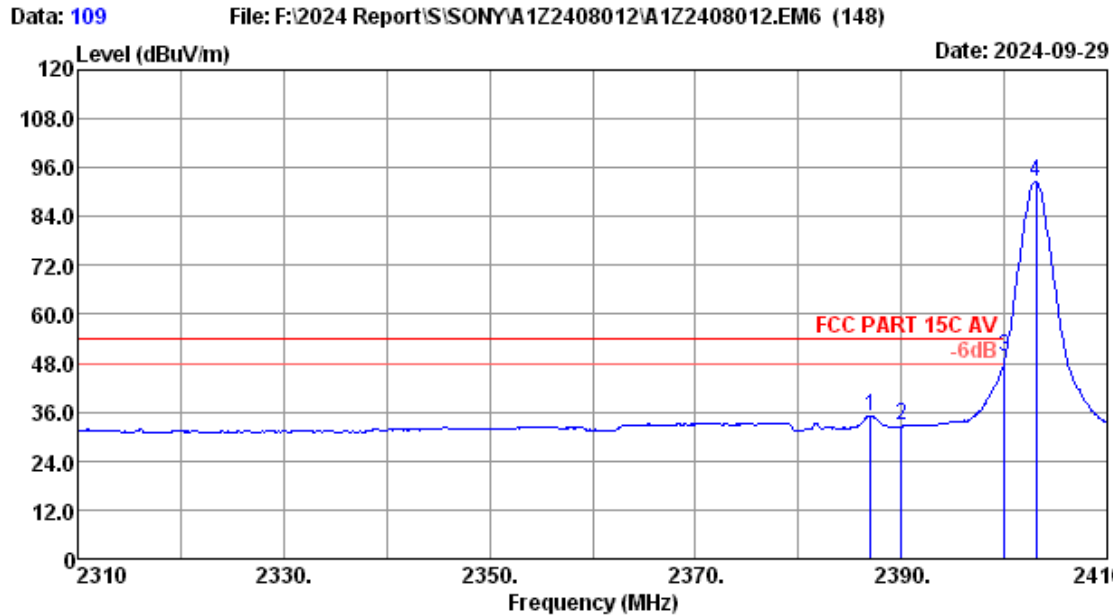

Site no. : 3m Chamber Data no. : 109
 Dis. / Ant. : 3m 2022 3115-4580 Ant. pol. : HORIZONTAL
 Limit : FCC PART 15C AV
 Env. / Ins. : 21.8°C/53.9% Engineer : epoch
 Test Mode : 2.4G 2403MHz ANTA TX Mode

No.	Freq. (MHz)	Ant. Factor (dB/m)	Cable Loss (dB)	Reading (dBuV)	Amp factor (dB)	Emission Level (dBuV/m)	Limits (dBuV/m)	Margin (dB)	Remark
1	2387.00	28.10	5.30	33.48	31.71	35.17	54.00	18.83	Average
2	2390.00	28.10	5.30	30.86	31.70	32.56	54.00	21.44	Average
3	2400.00	28.10	5.32	48.04	31.70	49.76	-----	-----	Average
4	2403.10	28.11	5.32	90.91	31.70	92.64	-----	-----	Average

Remarks: 1. Emission Level= Antenna Factor + Cable Loss + Reading -Amp factor.
 2. The emission levels that are 20dB below the official limit are not reported.

Data: 110 File: F:\2024 Report\SI\SONYA1Z2408012\A1Z2408012.EM6 (148) Date: 2024-09-29

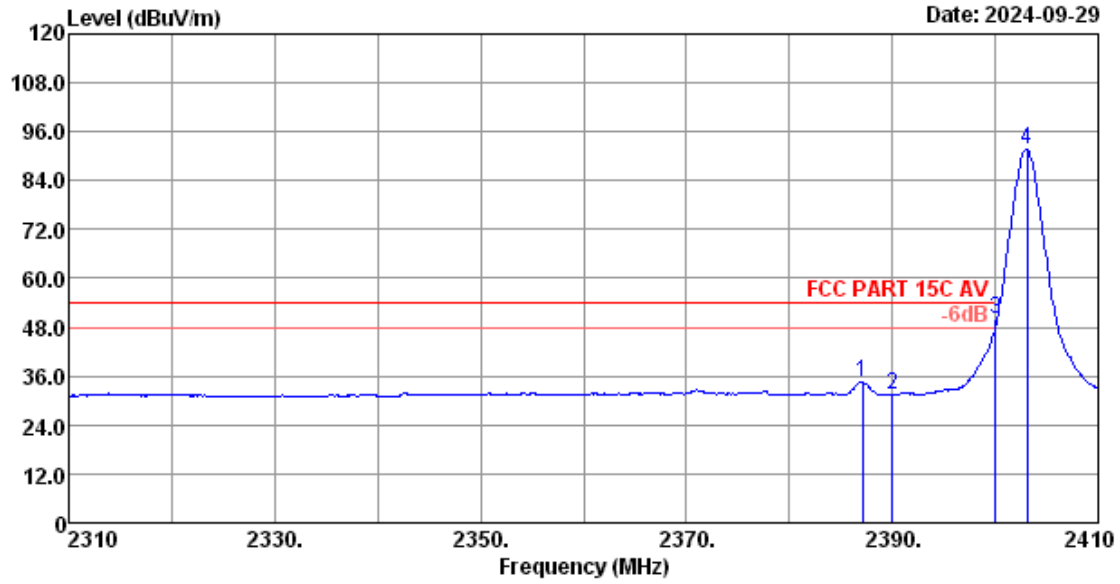

Site no. : 3m Chamber Data no. : 110
 Dis. / Ant. : 3m 2022 3115-4580 Ant. pol. : VERTICAL
 Limit : FCC PART 15C AV
 Env. / Ins. : 21.8°C/53.9% Engineer : epoch
 Test Mode : 2.4G 2403MHz ANTA TX Mode

No.	Freq. (MHz)	Ant. Factor (dB/m)	Cable Loss (dB)	Reading (dBUV)	Amp factor (dB)	Emission Level (dBUV/m)	Limits (dBUV/m)	Margin (dB)	Remark
1	2387.10	28.10	5.30	32.78	31.71	34.47	54.00	19.53	Average
2	2390.00	28.10	5.30	29.80	31.70	31.50	54.00	22.50	Average
3	2400.00	28.10	5.32	48.43	31.70	50.15	-----	-----	Average
4	2403.10	28.11	5.32	89.95	31.70	91.68	-----	-----	Average

Remarks: 1. Emission Level= Antenna Factor + Cable Loss + Reading -Amp factor.
 2. The emission levels that are 20dB below the official limit are not reported.

Data: 111 File: F:\2024 Report\SONYA1Z2408012\A1Z2408012.EM6 (148) Date: 2024-09-29

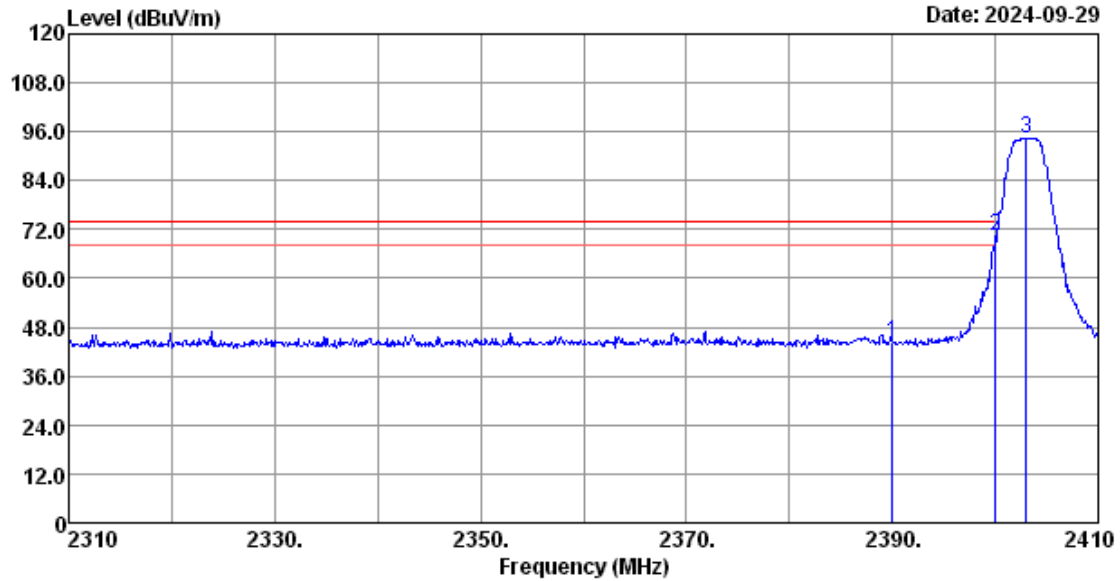

Site no. : 3m Chamber Data no. : 111
 Dis. / Ant. : 3m 2022 3115-4580 Ant. pol. : VERTICAL
 Limit : FCC PART 15C PEAK
 Env. / Ins. : 21.8°C/53.9% Engineer : epoch
 Test Mode : 2.4G 2403MHz ANTA TX Mode

No.	Freq. (MHz)	Ant. Factor (dB/m)	Cable Loss (dB)	Reading (dBuV)	Amp factor (dB)	Emission Level (dBuV/m)	Limits (dBuV/m)	Margin (dB)	Remark
1	2390.00	28.10	5.30	42.55	31.70	44.25	74.00	29.75	Peak
2	2400.00	28.10	5.32	68.77	31.70	70.49	-----	-----	Peak
3	2403.00	28.11	5.32	92.43	31.70	94.16	-----	-----	Peak

Remarks: 1. Emission Level= Antenna Factor + Cable Loss + Reading -Amp factor.
 2. The emission levels that are 20dB below the official limit are not reported.

Data: 112 File: F:\2024 Report\SONYA1Z2408012\A1Z2408012.EM6 (148) Date: 2024-09-29

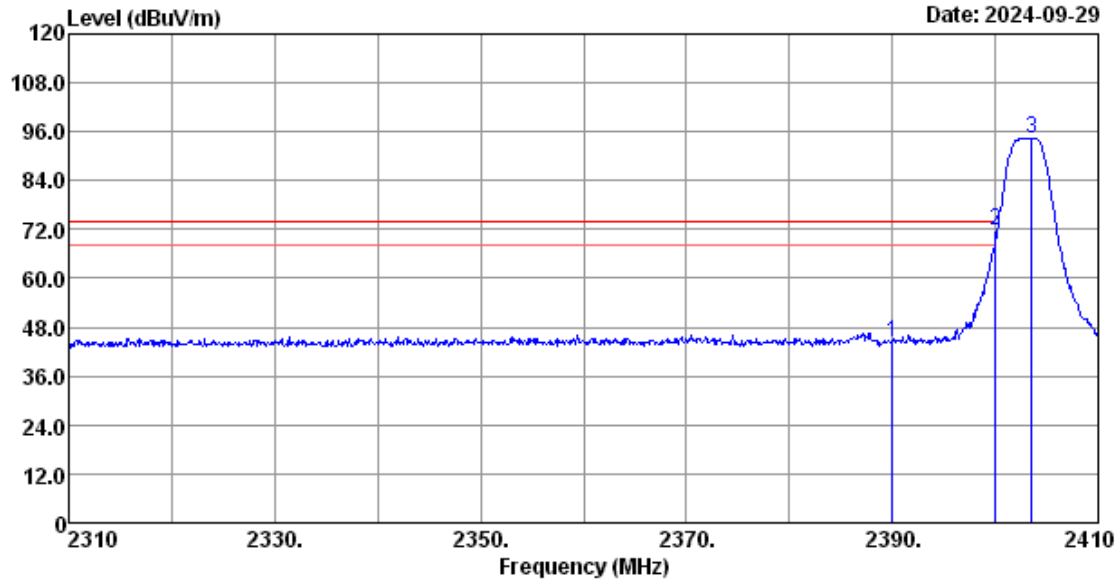

Site no. : 3m Chamber Data no. : 112
 Dis. / Ant. : 3m 2022 3115-4580 Ant. pol. : HORIZONTAL
 Limit : FCC PART 15C PEAK
 Env. / Ins. : 21.8°C/53.9% Engineer : epoch
 Test Mode : 2.4G 2403MHz ANTA TX Mode

No.	Freq. (MHz)	Ant. Factor (dB/m)	Cable Loss (dB)	Reading (dBuV)	Amp factor (dB)	Emission Level (dBuV/m)	Limits (dBuV/m)	Margin (dB)	Remark
1	2390.00	28.10	5.30	42.53	31.70	44.23	74.00	29.77	Peak
2	2400.00	28.10	5.32	70.19	31.70	71.91	-----	-----	Peak
3	2403.50	28.11	5.32	92.50	31.70	94.23	-----	-----	Peak

Remarks: 1. Emission Level= Antenna Factor + Cable Loss + Reading -Amp factor.
 2. The emission levels that are 20dB below the official limit are not reported.

Data: 113 File: F:\2024 Report\SONYA1Z2408012\A1Z2408012.EM6 (148) Date: 2024-09-29

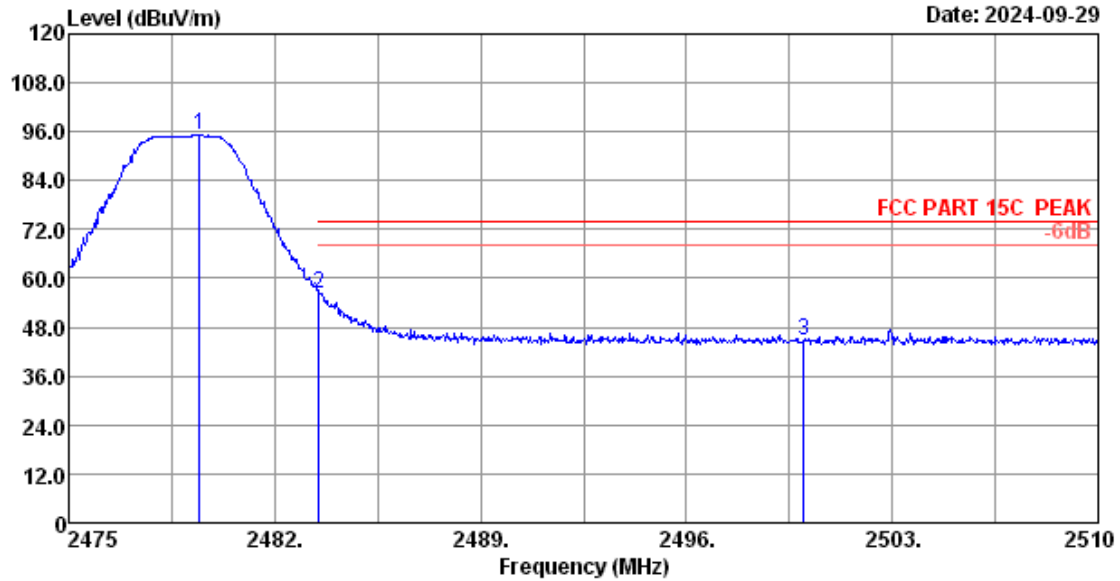

Site no. : 3m Chamber Data no. : 113
 Dis. / Ant. : 3m 2022 3115-4580 Ant. pol. : VERTICAL
 Limit : FCC PART 15C PEAK
 Env. / Ins. : 21.8°C/53.9% Engineer : epoch
 Test Mode : 2.4G 2479MHz ANTA TX Mode

No.	Freq. (MHz)	Ant. Factor (dB/m)	Cable Loss (dB)	Reading (dBuV)	Amp factor (dB)	Emission Level (dBuV/m)	Limits (dBuV/m)	Margin (dB)	Remark
1	2479.45	28.30	5.41	92.96	31.66	95.01	-----	-----	Peak
2	2483.50	28.30	5.41	54.11	31.66	56.16	74.00	17.84	Peak
3	2500.00	28.30	5.44	42.77	31.65	44.86	74.00	29.14	Peak

Remarks: 1. Emission Level= Antenna Factor + Cable Loss + Reading -Amp factor.
 2. The emission levels that are 20dB below the official limit are not reported.

Data: 114 File: F:\2024 Report\SONYA1Z2408012\A1Z2408012.EM6 (148) Date: 2024-09-29

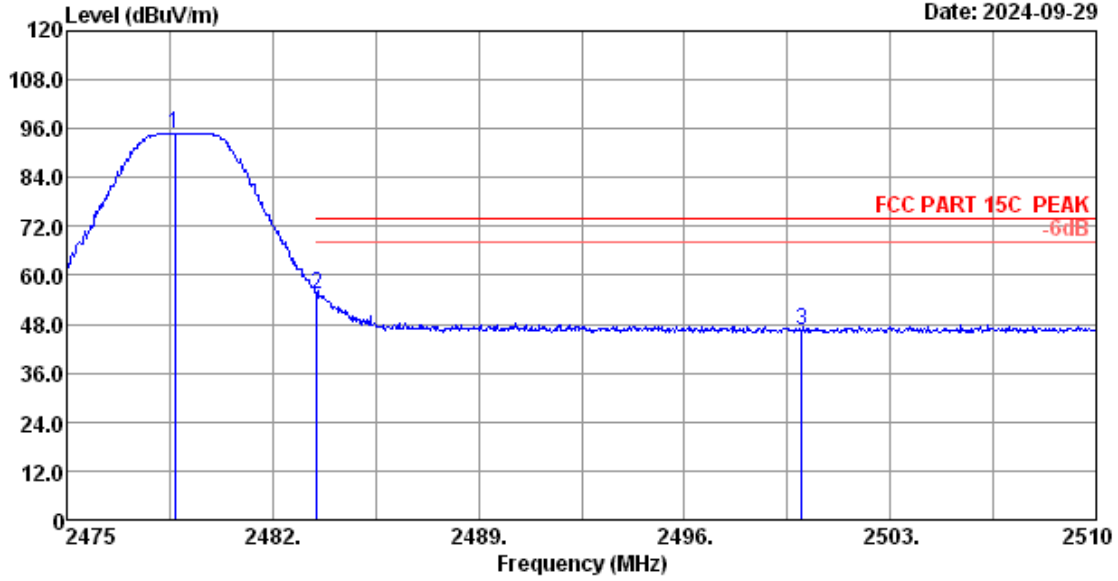

Site no. : 3m Chamber Data no. : 114
 Dis. / Ant. : 3m 2022 3115-4580 Ant. pol. : HORIZONTAL
 Limit : FCC PART 15C PEAK
 Env. / Ins. : 21.8°C/53.9% Engineer : epoch
 Test Mode : 2.4G 2479MHz ANTA TX Mode

No.	Freq. (MHz)	Ant. Factor (dB/m)	Cable Loss (dB)	Reading (dBuV)	Amp factor (dB)	Emission Level (dBuV/m)	Limits (dBuV/m)	Margin (dB)	Remark
1	2478.68	28.30	5.41	92.64	31.66	94.69	-----	-----	Peak
2	2483.50	28.30	5.41	53.48	31.66	55.53	74.00	18.47	Peak
3	2500.00	28.30	5.44	44.19	31.65	46.28	74.00	27.72	Peak

Remarks: 1. Emission Level= Antenna Factor + Cable Loss + Reading -Amp factor.
 2. The emission levels that are 20dB below the official limit are not reported.

Data: 115 File: F:\2024 Report\SONYA1Z2408012\A1Z2408012.EM6 (148) Date: 2024-09-29

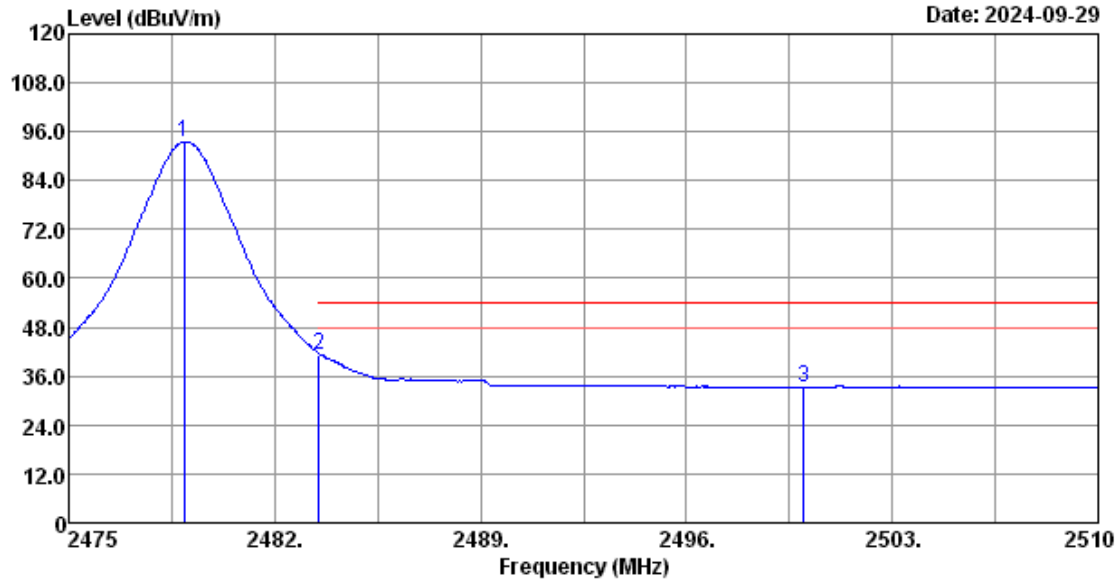

Site no. : 3m Chamber Data no. : 115
 Dis. / Ant. : 3m 2022 3115-4580 Ant. pol. : HORIZONTAL
 Limit : FCC PART 15C AV
 Env. / Ins. : 21.8°C/53.9% Engineer : epoch
 Test Mode : 2.4G 2479MHz ANTA TX Mode

No.	Freq. (MHz)	Ant. Factor (dB/m)	Cable Loss (dB)	Reading (dBuV)	Amp factor (dB)	Emission Level (dBuV/m)	Limits (dBuV/m)	Margin (dB)	Remark
1	2478.92	28.30	5.41	91.44	31.66	93.49	-----	-----	Average
2	2483.50	28.30	5.41	39.06	31.66	41.11	54.00	12.89	Average
3	2500.00	28.30	5.44	31.14	31.65	33.23	54.00	20.77	Average

Remarks: 1. Emission Level= Antenna Factor + Cable Loss + Reading -Amp factor.
 2. The emission levels that are 20dB below the official limit are not reported.

Data: 116 File: F:\2024 Report\SONYA1Z2408012\A1Z2408012.EM6 (148) Date: 2024-09-29

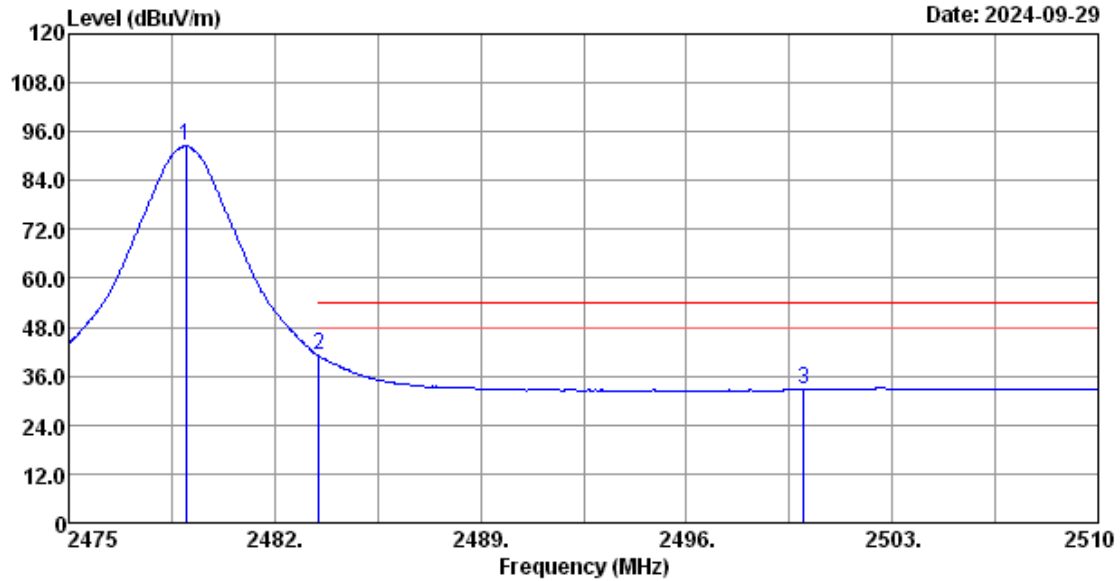

Site no. : 3m Chamber Data no. : 116
 Dis. / Ant. : 3m 2022 3115-4580 Ant. pol. : VERTICAL
 Limit : FCC PART 15C AV
 Env. / Ins. : 21.8°C/53.9% Engineer : epoch
 Test Mode : 2.4G 2479MHz ANTA TX Mode

No.	Freq. (MHz)	Ant. Factor (dB/m)	Cable Loss (dB)	Reading (dBuV)	Amp factor (dB)	Emission Level (dBuV/m)	Limits (dBuV/m)	Margin (dB)	Remark
1	2478.99	28.30	5.41	90.34	31.66	92.39	-----	-----	Average
2	2483.50	28.30	5.41	39.06	31.66	41.11	54.00	12.89	Average
3	2500.00	28.30	5.44	30.53	31.65	32.62	54.00	21.38	Average

Remarks: 1. Emission Level= Antenna Factor + Cable Loss + Reading -Amp factor.
 2. The emission levels that are 20dB below the official limit are not reported.

ANT B

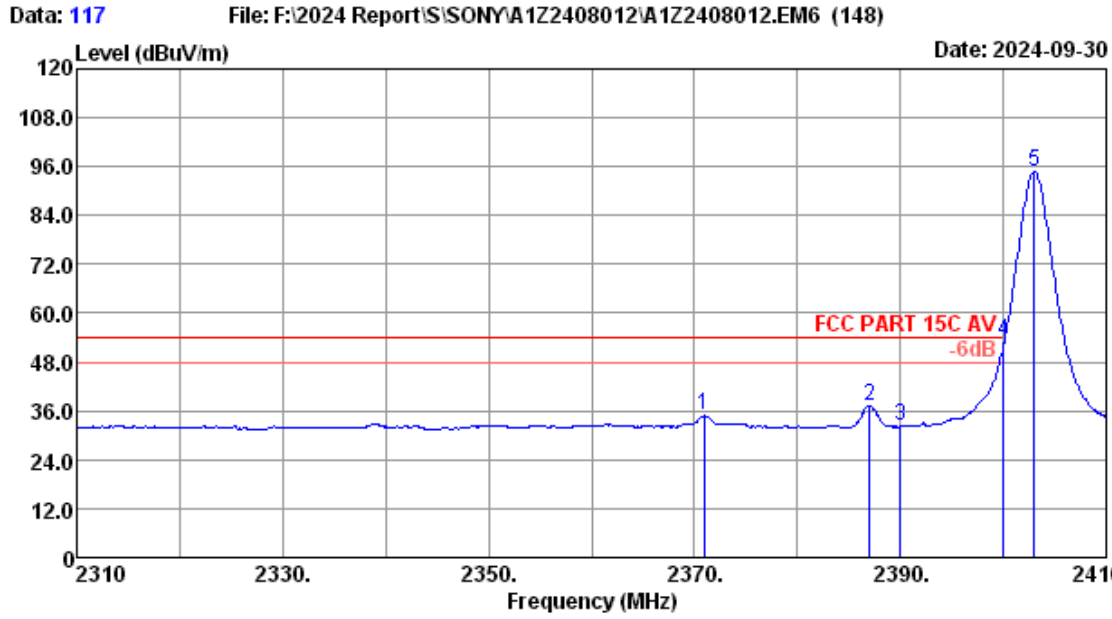

Site no. : 3m Chamber Data no. : 117
 Dis. / Ant. : 3m 2022 3115-4580 Ant. pol. : VERTICAL
 Limit : FCC PART 15C AV
 Env. / Ins. : 21.8°C/53.9% Engineer : epoch
 Test Mode : 2.4G 2403MHz ANTB TX Mode

No.	Freq. (MHz)	Ant. Factor (dB/m)	Cable Loss (dB)	Reading (dBuV)	Amp factor (dB)	Emission Level (dBuV/m)	Limits (dBuV/m)	Margin (dB)	Remark
1	2370.90	28.10	5.28	33.15	31.71	34.82	54.00	19.18	Average
2	2387.00	28.10	5.30	35.65	31.71	37.34	54.00	16.66	Average
3	2390.00	28.10	5.30	30.42	31.70	32.12	54.00	21.88	Average
4	2400.00	28.10	5.32	51.43	31.70	53.15	-----	-----	Average
5	2403.00	28.11	5.32	93.10	31.70	94.83	-----	-----	Average

Remarks: 1. Emission Level= Antenna Factor + Cable Loss + Reading -Amp factor.
 2. The emission levels that are 20dB below the official limit are not reported.

Data: 118 File: F:\2024 Report\SONYA1Z2408012\A1Z2408012.EM6 (148) Date: 2024-09-30

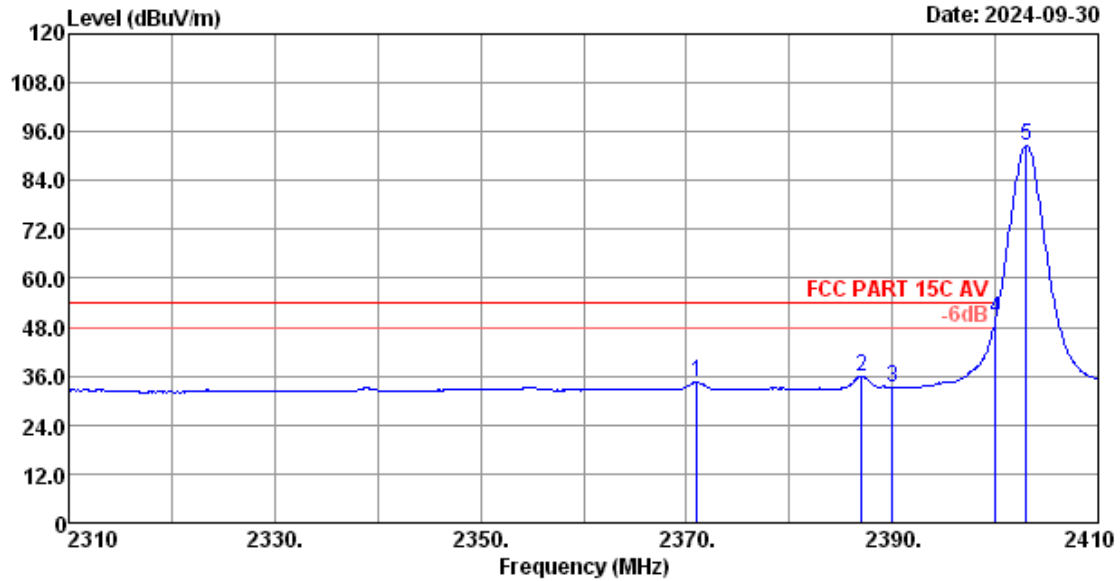

Site no. : 3m Chamber Data no. : 118
 Dis. / Ant. : 3m 2022 3115-4580 Ant. pol. : HORIZONTAL
 Limit : FCC PART 15C AV
 Env. / Ins. : 21.8°C/53.9% Engineer : epoch
 Test Mode : 2.4G 2403MHz ANTB TX Mode

No.	Freq. (MHz)	Ant. Factor (dB/m)	Cable Loss (dB)	Reading (dBuV)	Amp factor (dB)	Emission Level (dBuV/m)	Limits (dBuV/m)	Margin (dB)	Remark
1	2371.00	28.10	5.28	32.83	31.71	34.50	54.00	19.50	Average
2	2387.00	28.10	5.30	34.33	31.71	36.02	54.00	17.98	Average
3	2390.00	28.10	5.30	31.57	31.70	33.27	54.00	20.73	Average
4	2400.00	28.10	5.32	48.10	31.70	49.82	-----	-----	Average
5	2403.00	28.11	5.32	90.98	31.70	92.71	-----	-----	Average

Remarks: 1. Emission Level= Antenna Factor + Cable Loss + Reading - Amp factor.
 2. The emission levels that are 20dB below the official limit are not reported.

Data: 119 File: F:\2024 Report\SONYA1Z2408012\A1Z2408012.EM6 (148) Date: 2024-09-30

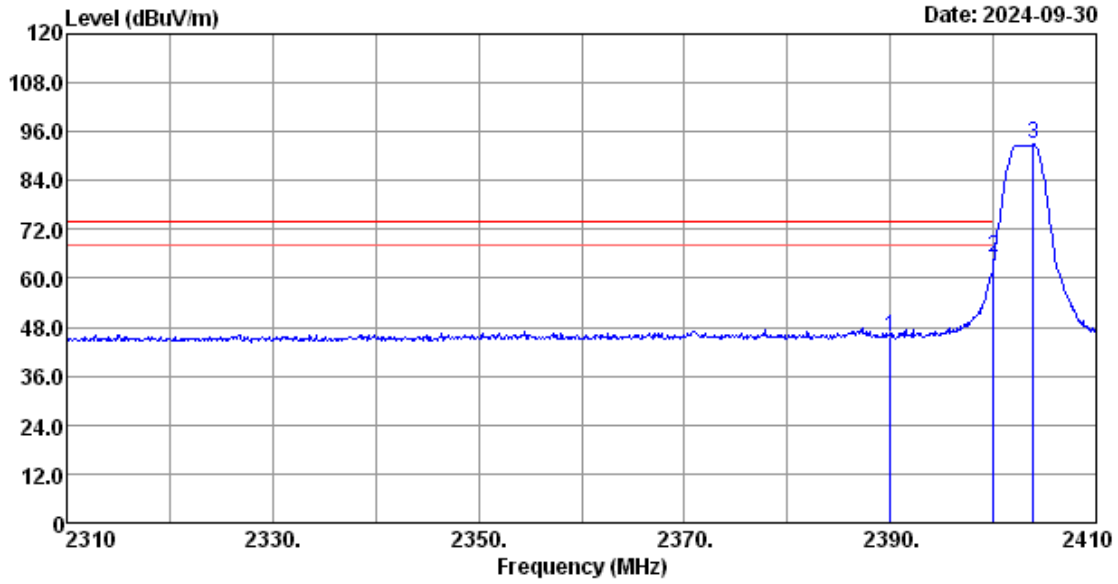

Site no. : 3m Chamber Data no. : 119
 Dis. / Ant. : 3m 2022 3115-4580 Ant. pol. : HORIZONTAL
 Limit : FCC PART 15C PEAK
 Env. / Ins. : 21.8°C/53.9% Engineer : epoch
 Test Mode : 2.4G 2403MHz ANTB TX Mode

No.	Freq. (MHz)	Ant. Factor (dB/m)	Cable Loss (dB)	Reading (dBuV)	Amp factor (dB)	Emission Level (dBuV/m)	Limits (dBuV/m)	Margin (dB)	Remark
1	2390.00	28.10	5.30	43.92	31.70	45.62	74.00	28.38	Peak
2	2400.00	28.10	5.32	63.54	31.70	65.26	-----	-----	Peak
3	2403.90	28.12	5.32	91.06	31.70	92.80	-----	-----	Peak

Remarks: 1. Emission Level= Antenna Factor + Cable Loss + Reading -Amp factor.
 2. The emission levels that are 20dB below the official limit are not reported.

Data: 120 File: F:\2024 Report\SONYA1Z2408012\A1Z2408012.EM6 (148) Date: 2024-09-30

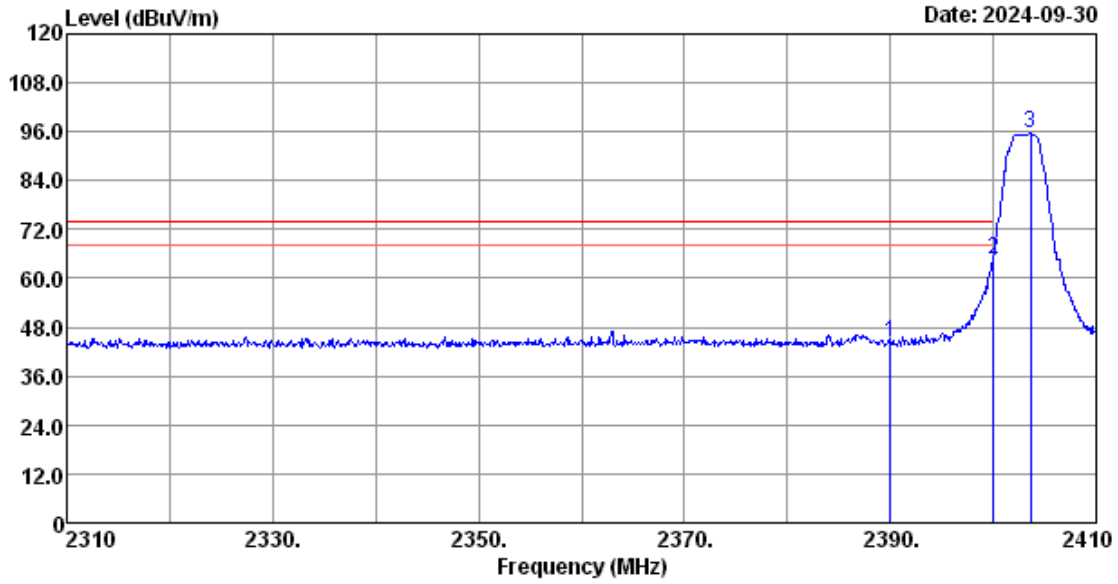

Site no. : 3m Chamber Data no. : 120
 Dis. / Ant. : 3m 2022 3115-4580 Ant. pol. : VERTICAL
 Limit : FCC PART 15C PEAK
 Env. / Ins. : 21.8°C/53.9% Engineer : epoch
 Test Mode : 2.4G 2403MHz ANTB TX Mode

No.	Freq. (MHz)	Ant. Factor (dB/m)	Cable Loss (dB)	Reading (dBuV)	Amp factor (dB)	Emission Level (dBuV/m)	Limits (dBuV/m)	Margin (dB)	Remark
1	2390.00	28.10	5.30	42.60	31.70	44.30	74.00	29.70	Peak
2	2400.00	28.10	5.32	62.85	31.70	64.57	-----	-----	Peak
3	2403.60	28.11	5.32	93.71	31.70	95.44	-----	-----	Peak

Remarks: 1. Emission Level= Antenna Factor + Cable Loss + Reading -Amp factor.
 2. The emission levels that are 20dB below the official limit are not reported.

Data: 121 File: F:\2024 Report\SONYA1Z2408012\A1Z2408012.EM6 (148) Date: 2024-09-30

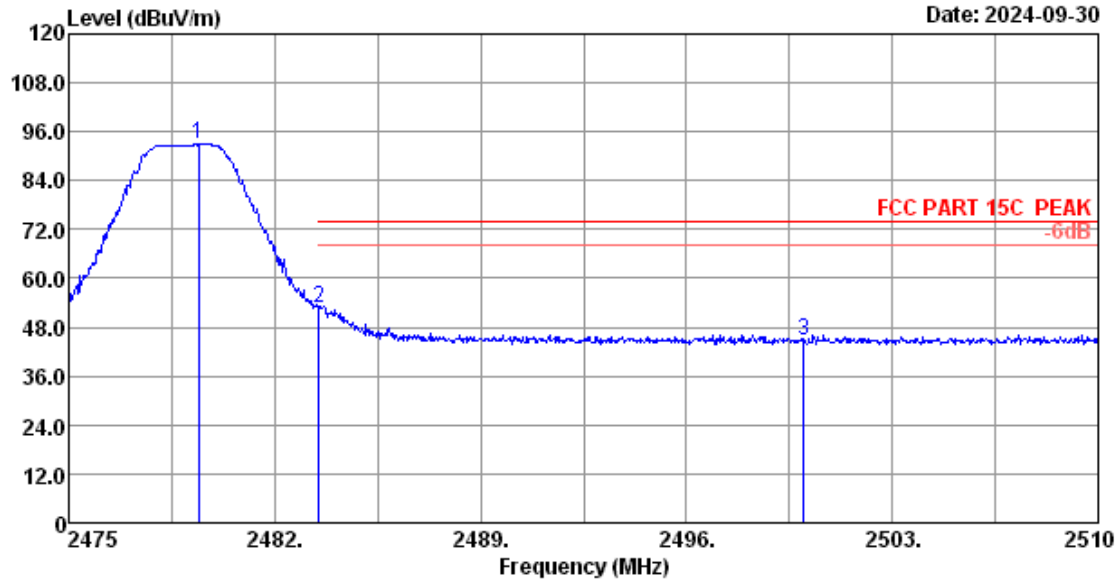

Site no. : 3m Chamber Data no. : 121
 Dis. / Ant. : 3m 2022 3115-4580 Ant. pol. : HORIZONTAL
 Limit : FCC PART 15C PEAK
 Env. / Ins. : 21.8°C/53.9% Engineer : epoch
 Test Mode : 2.4G 2479MHz ANTB TX Mode

No.	Freq. (MHz)	Ant. Factor (dB/m)	Cable Loss (dB)	Reading (dBuV)	Amp factor (dB)	Emission Level (dBuV/m)	Limits (dBuV/m)	Margin (dB)	Remark
1	2479.41	28.30	5.41	90.75	31.66	92.80	-----	-----	Peak
2	2483.50	28.30	5.41	50.52	31.66	52.57	74.00	21.43	Peak
3	2500.00	28.30	5.44	42.47	31.65	44.56	74.00	29.44	Peak

Remarks: 1. Emission Level= Antenna Factor + Cable Loss + Reading -Amp factor.
 2. The emission levels that are 20dB below the official limit are not reported.

Data: 122 File: F:\2024 Report\SONYA1Z2408012\A1Z2408012.EM6 (148) Date: 2024-09-30

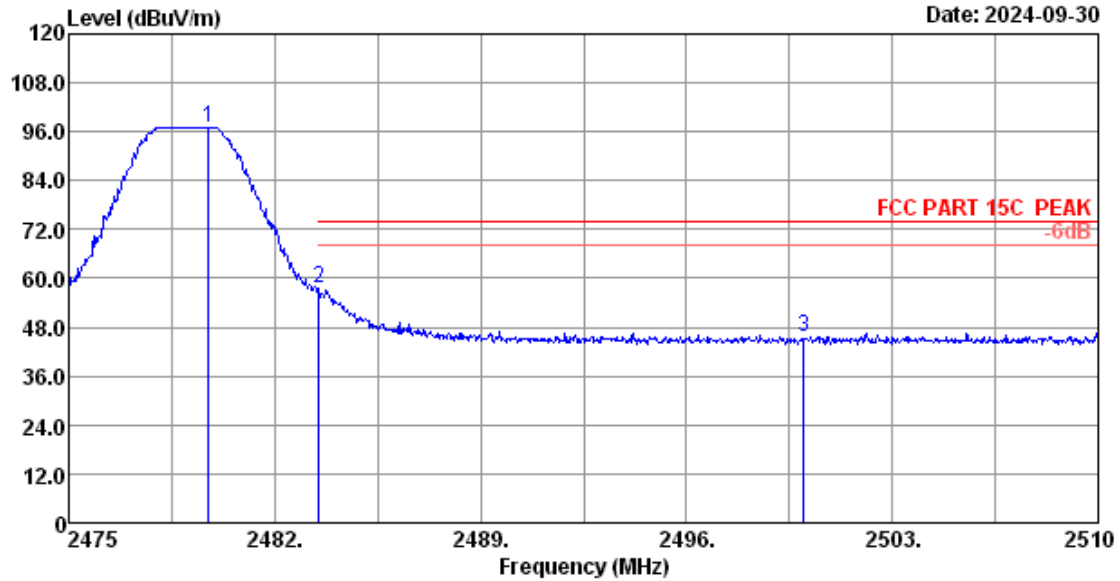

Site no. : 3m Chamber Data no. : 122
 Dis. / Ant. : 3m 2022 3115-4580 Ant. pol. : VERTICAL
 Limit : FCC PART 15C PEAK
 Env. / Ins. : 21.8°C/53.9% Engineer : epoch
 Test Mode : 2.4G 2479MHz ANTB TX Mode

No.	Freq. (MHz)	Ant. Factor (dB/m)	Cable Loss (dB)	Reading (dBuV)	Amp factor (dB)	Emission Level (dBuV/m)	Limits (dBuV/m)	Margin (dB)	Remark
1	2479.76	28.30	5.41	95.05	31.66	97.10	-----	-----	Peak
2	2483.50	28.30	5.41	55.70	31.66	57.75	74.00	16.25	Peak
3	2500.00	28.30	5.44	43.30	31.65	45.39	74.00	28.61	Peak

Remarks: 1. Emission Level= Antenna Factor + Cable Loss + Reading -Amp factor.
 2. The emission levels that are 20dB below the official limit are not reported.

Data: 123 File: F:\2024 Report\SONYA1Z2408012\A1Z2408012.EM6 (148) Date: 2024-09-30

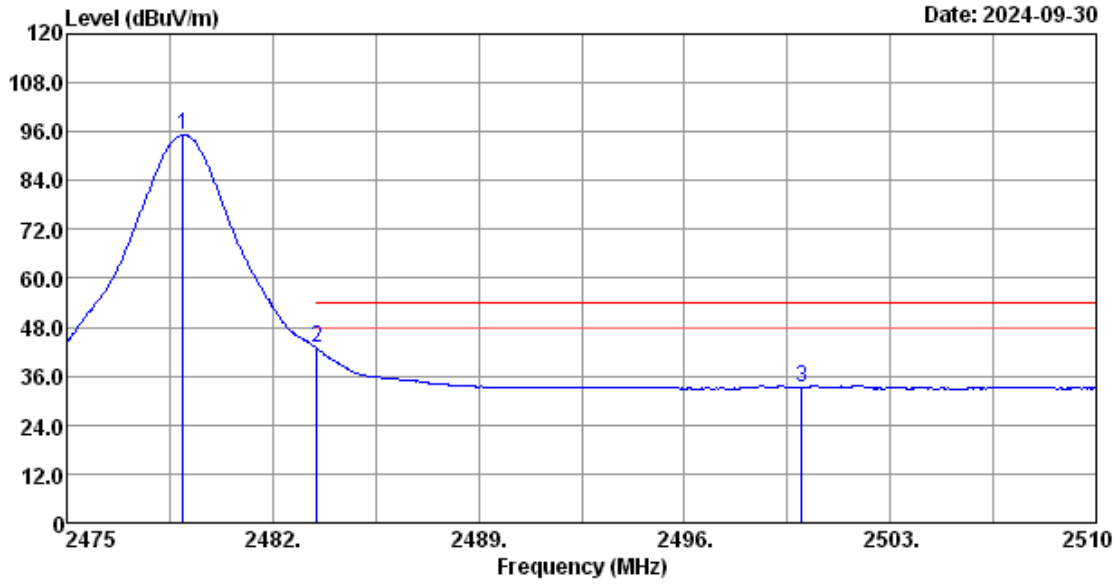

Site no. : 3m Chamber Data no. : 123
 Dis. / Ant. : 3m 2022 3115-4580 Ant. pol. : VERTICAL
 Limit : FCC PART 15C AV
 Env. / Ins. : 21.8°C/53.9% Engineer : epoch
 Test Mode : 2.4G 2479MHz ANTB TX Mode

No.	Freq. (MHz)	Ant. Factor (dB/m)	Cable Loss (dB)	Reading (dBuV)	Amp factor (dB)	Emission Level (dBuV/m)	Limits (dBuV/m)	Margin (dB)	Remark
1	2478.96	28.30	5.41	93.15	31.66	95.20	-----	-----	Average
2	2483.50	28.30	5.41	40.83	31.66	42.88	54.00	11.12	Average
3	2500.00	28.30	5.44	31.33	31.65	33.42	54.00	20.58	Average

Remarks: 1. Emission Level= Antenna Factor + Cable Loss + Reading -Amp factor.
 2. The emission levels that are 20dB below the official limit are not reported.

Data: 124 File: F:\2024 Report\SONYA1Z2408012\A1Z2408012.EM6 (148) Date: 2024-09-30

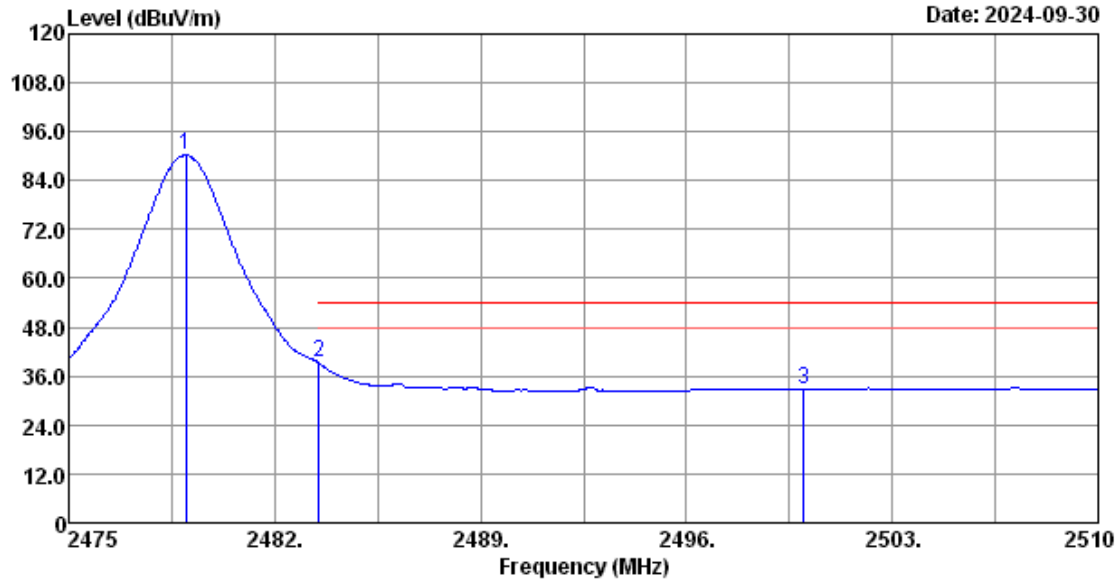

Site no. : 3m Chamber Data no. : 124
 Dis. / Ant. : 3m 2022 3115-4580 Ant. pol. : HORIZONTAL
 Limit : FCC PART 15C AV
 Env. / Ins. : 21.8°C/53.9% Engineer : epoch
 Test Mode : 2.4G 2479MHz ANTB TX Mode

No.	Freq. (MHz)	Ant. Factor (dB/m)	Cable Loss (dB)	Reading (dBuV)	Amp factor (dB)	Emission Level (dBuV/m)	Limits (dBuV/m)	Margin (dB)	Remark
1	2478.99	28.30	5.41	88.18	31.66	90.23	-----	-----	Average
2	2483.50	28.30	5.41	37.34	31.66	39.39	54.00	14.61	Average
3	2500.00	28.30	5.44	30.61	31.65	32.70	54.00	21.30	Average

Remarks: 1. Emission Level= Antenna Factor + Cable Loss + Reading -Amp factor.
 2. The emission levels that are 20dB below the official limit are not reported.

7. 6dB & 99% Bandwidth Test

7.1. Test Equipment

Item	Equipment	Manufacturer	Model No.	Serial No.	Last Cal.	Cal. Interval
1.	PXA Signal Analyzer	Agilent	N9030A	MY51380221	Mar.16,24	1 Year
2.	RF Cable	Eastsheep	RM086-SMA/N-JJ-2000	NO.1	Jun.19,24	1 Year
3.	Attenuator(10dB)	Agilent	8491B	MY39269201	Mar.16,24	1 Year

7.2. Block Diagram of Test Setup



7.3. Limit

For direct sequence systems, the minimum 6dB bandwidth shall be at least 500kHz

7.4. Test Procedure

Use the test method described in ANSI C63.10 Section 11.8:

The automatic bandwidth measurement capability of an instrument may be employed using the X dB bandwidth mode with X set to 6 dB, if the functionality described in 11.8.1 (i.e., $RBW = 100\text{ kHz}$, $VBW \geq 3 \times RBW$, and peak detector with maximum hold) is implemented by the instrumentation function. When using this capability, care shall be taken so that the bandwidth measurement is not influenced by any intermediate power nulls in the fundamental emission that might be $\geq 6\text{ dB}$.

Use the test method described in ANSI C63.10 Section 6.9.2:

The occupied bandwidth is the frequency bandwidth such that, below its lower and above its upper frequency limits, the mean powers are each equal to 0.5% of the total mean power of the given emission. The following procedure shall be used for measuring 99% power bandwidth:

- The instrument center frequency is set to the nominal EUT channel center frequency. The frequency span for the spectrum analyzer shall be between 1.5 times and 5.0 times the OBW.
- The nominal IF filter bandwidth (3 dB RBW) shall be in the range of 1% to 5% of the OBW, and VBW shall be approximately three times the RBW, unless otherwise specified by the applicable requirement.
- Set the reference level of the instrument as required, keeping the signal from exceeding the maximum input mixer level for linear operation. In general, the peak of the spectral envelope shall be more than $[10 \log (OBW/RBW)]$ below the reference level. Specific guidance is given in 4.1.5.2.
- Step a) through step c) might require iteration to adjust within the specified range.
- Video averaging is not permitted. Where practical, a sample detection and single sweep mode shall be used. Otherwise, peak detection and max hold mode (until the trace stabilizes) shall be used.
- Use the 99% power bandwidth function of the instrument (if available) and report the measured bandwidth.

- g) If the instrument does not have a 99% power bandwidth function, then the trace data points are recovered and directly summed in linear power terms. The recovered amplitude data points, beginning at the lowest frequency, are placed in a running sum until 0.5% of the total is reached; that frequency is recorded as the lower frequency. The process is repeated until 99.5% of the total is reached; that frequency is recorded as the upper frequency. The 99% power bandwidth is the difference between these two frequencies.
- h) The occupied bandwidth shall be reported by providing plot(s) of the measuring instrument display; the plot axes and the scale units per division shall be clearly labeled. Tabular data may be reported in addition to the plot(s).

7.5.Test Results

EUT: Active Subwoofer		
M/N: YY2088C2		
Test date:2024-09-06~24	Pressure: 102.1±1.0 kpa	Humidity: 51.1±3.0%
Tested by: Lili	Test site: RF site	Temperature:22.8±0.6 °C

Test Mode	Frequency (MHz)	6dB bandwidth (MHz)		Limit (KHz)
		ANTA	ANTB	
GFSK	2403	1.208	1.068	≥ 500
	2441	1.188	1.134	
	2479	1.309	1.223	

Conclusion : PASS

ANT A

2403MHz:



2441MHz:

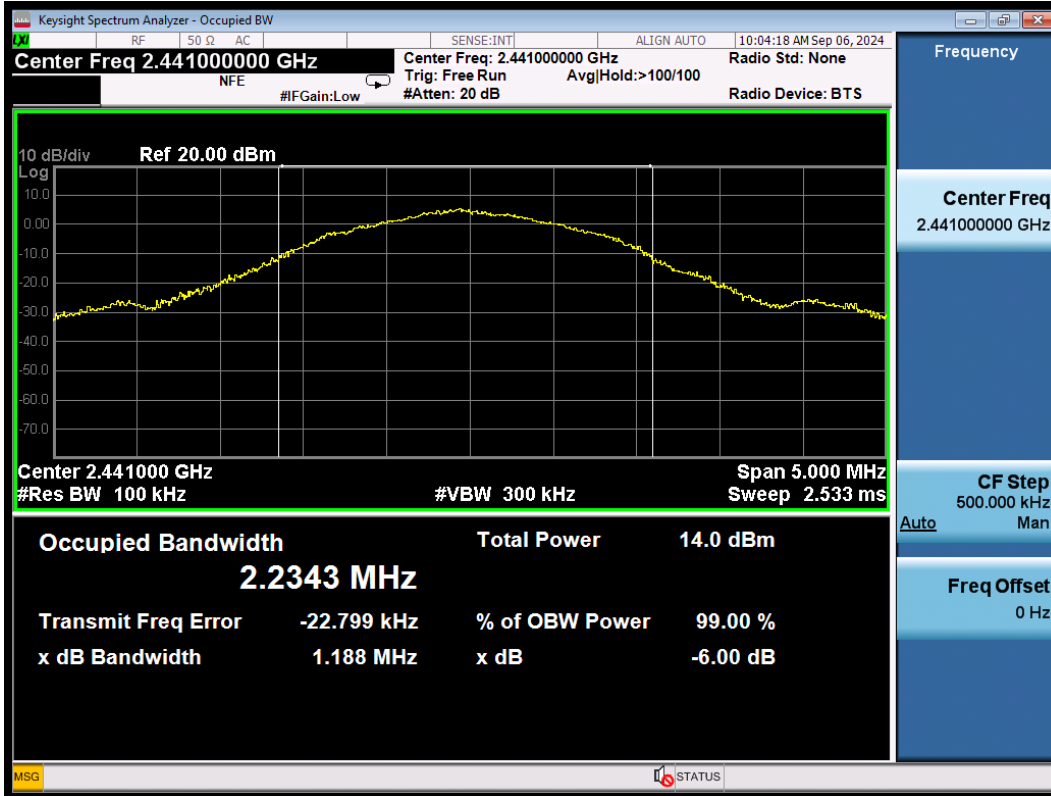

2479MHz:

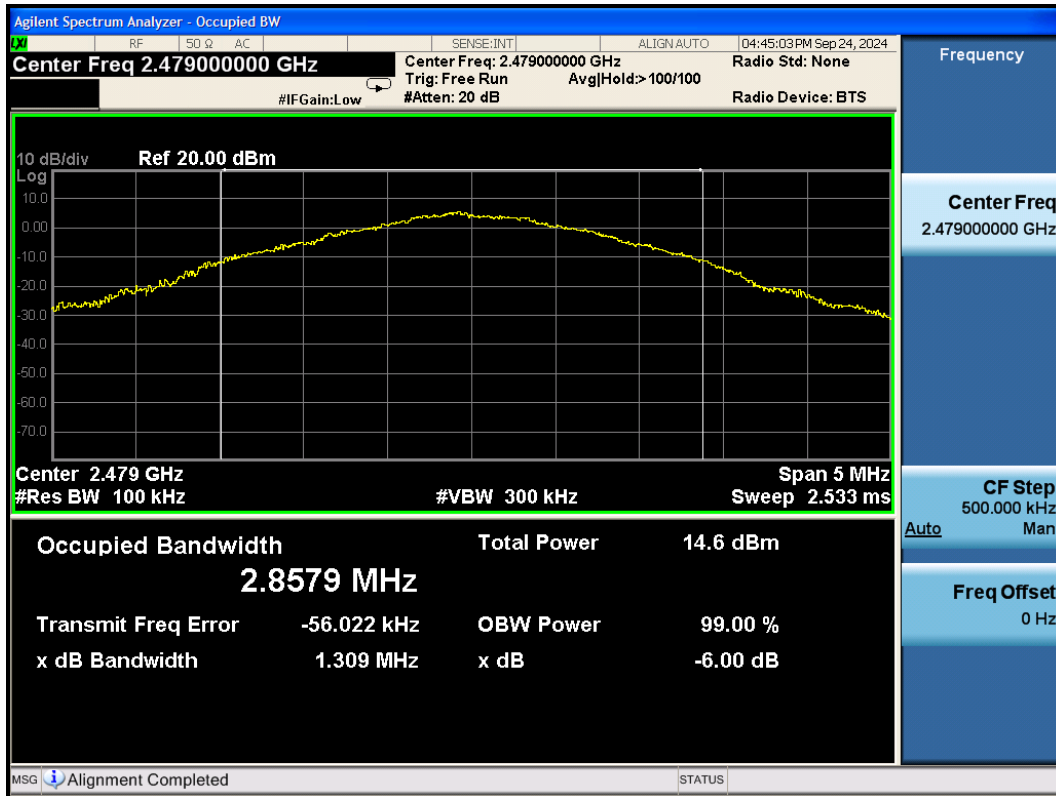

ANT B

2403MHz:



2441MHz:



2479MHz:

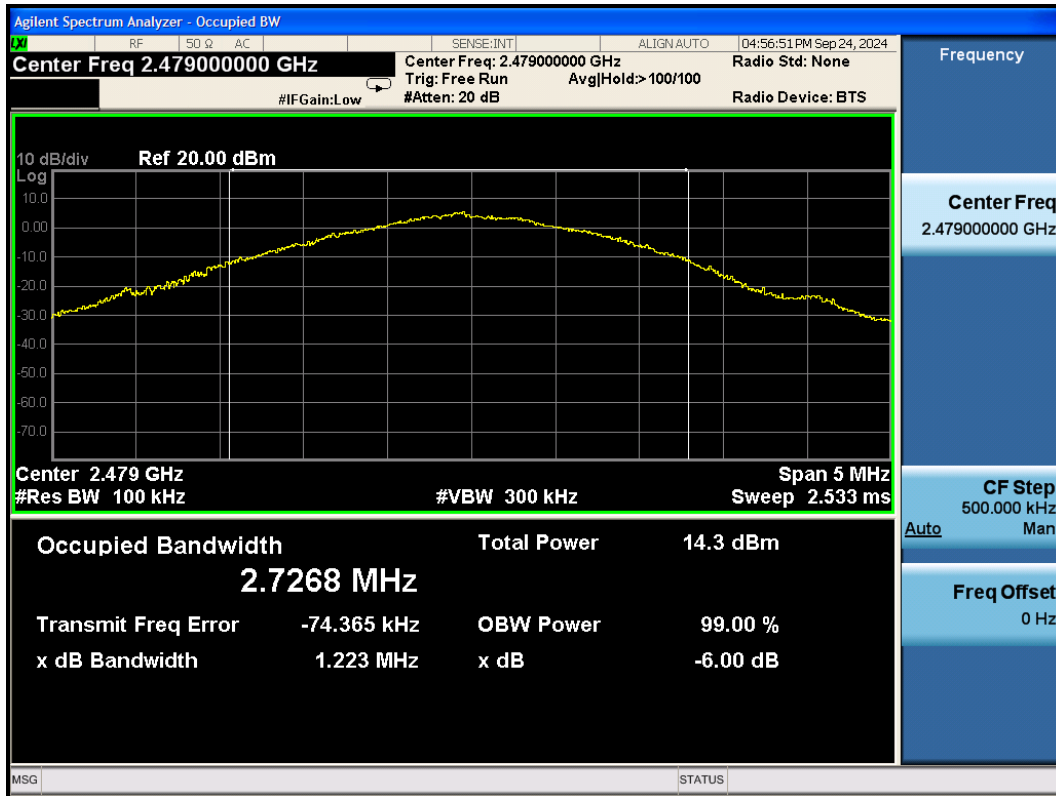

EUT: Active Subwoofer		
M/N: YY2088C2		
Test date:2024-10-23	Pressure: 102.1±1.0 kpa	Humidity: 51.1±3.0%
Tested by: Lili	Test site: RF site	Temperature:22.8±0.6 °C

Test Mode	Frequency (MHz)	99% bandwidth (MHz)		Limit (KHz)
		ANTA	ANTB	
GFSK	2403	2.4406	2.4991	≥ 500
	2441	2.5842	2.5869	
	2479	2.6968	2.7112	

Conclusion : PASS

ANT A

2403MHz:



2441MHz:

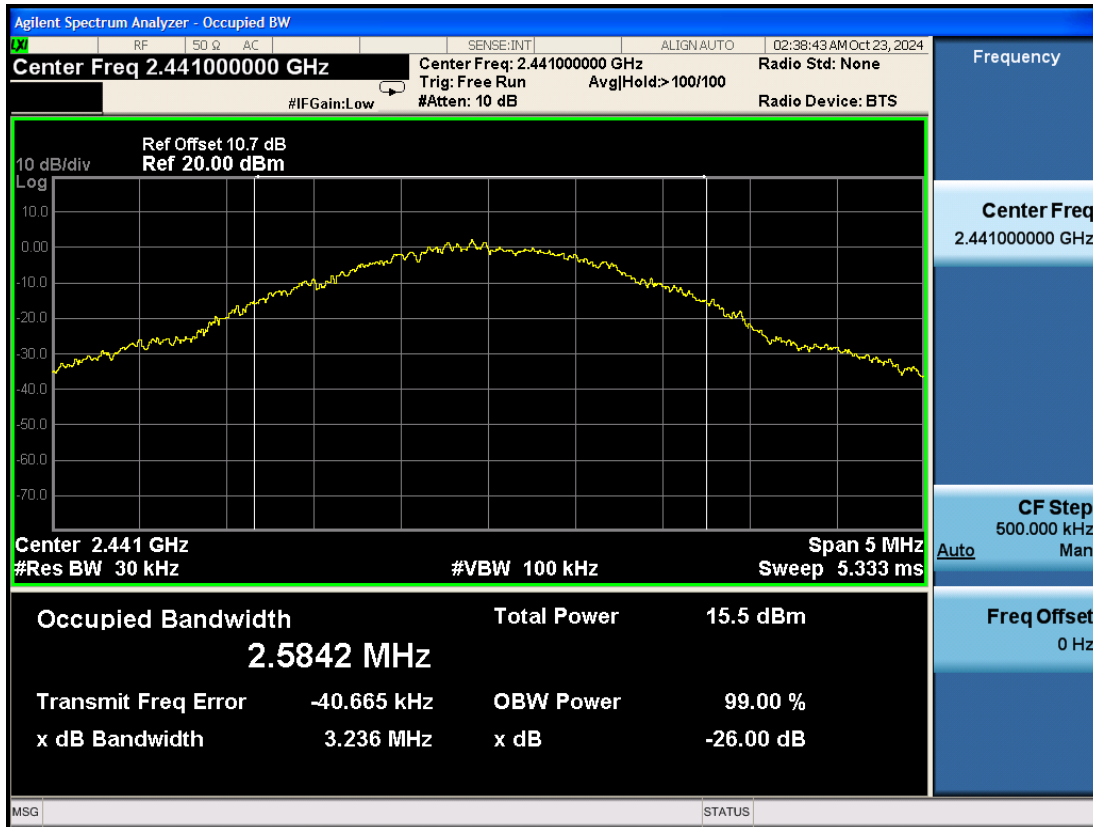

2479MHz:



ANT B

2403MHz:

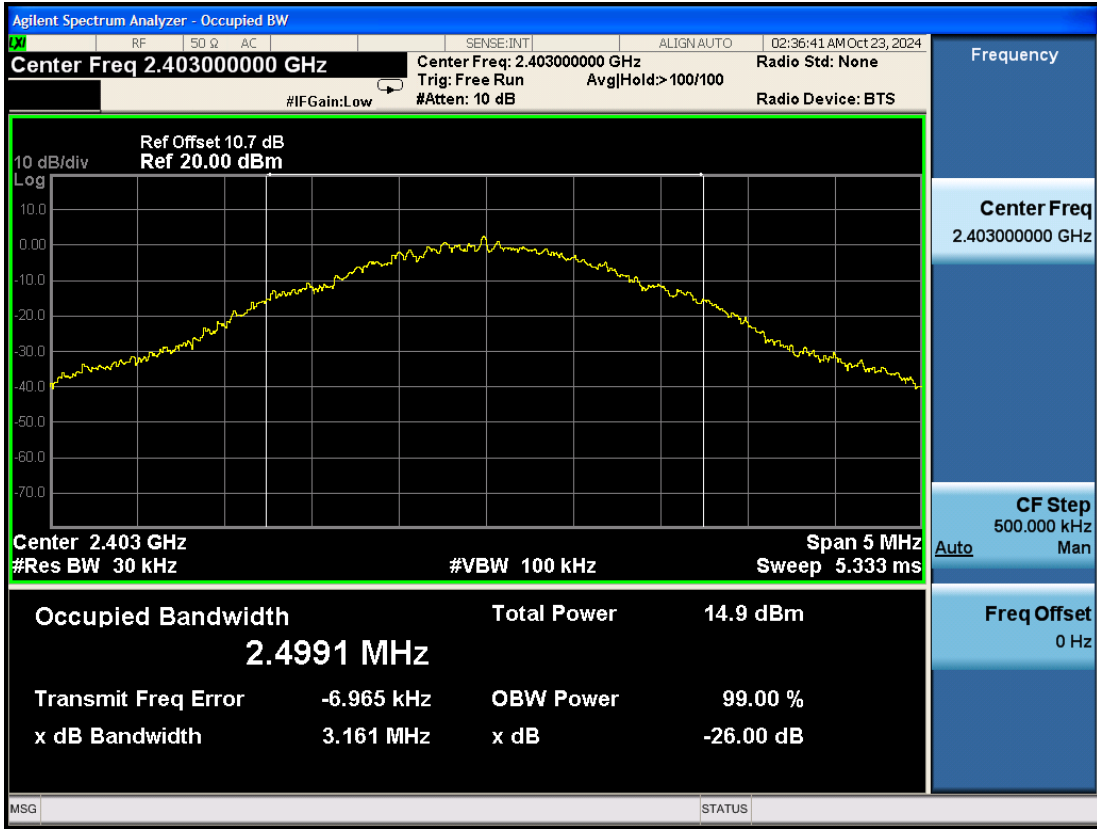

2441MHz:

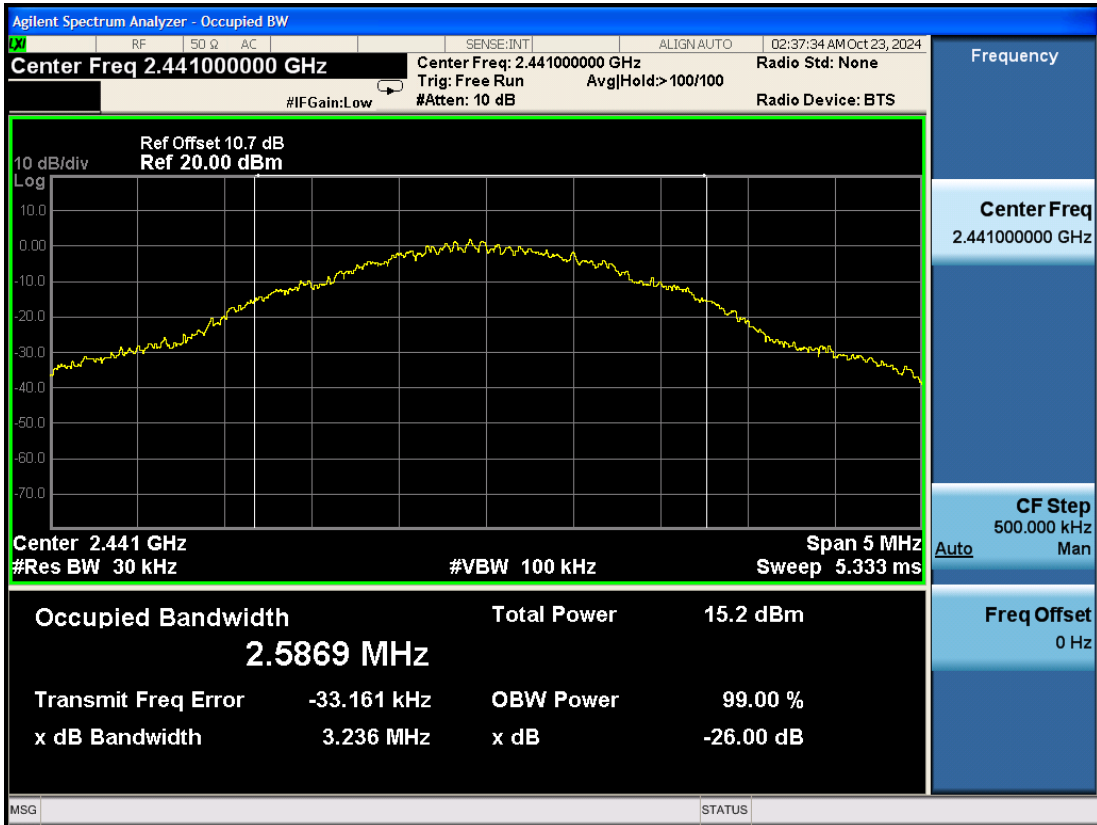

2479MHz:

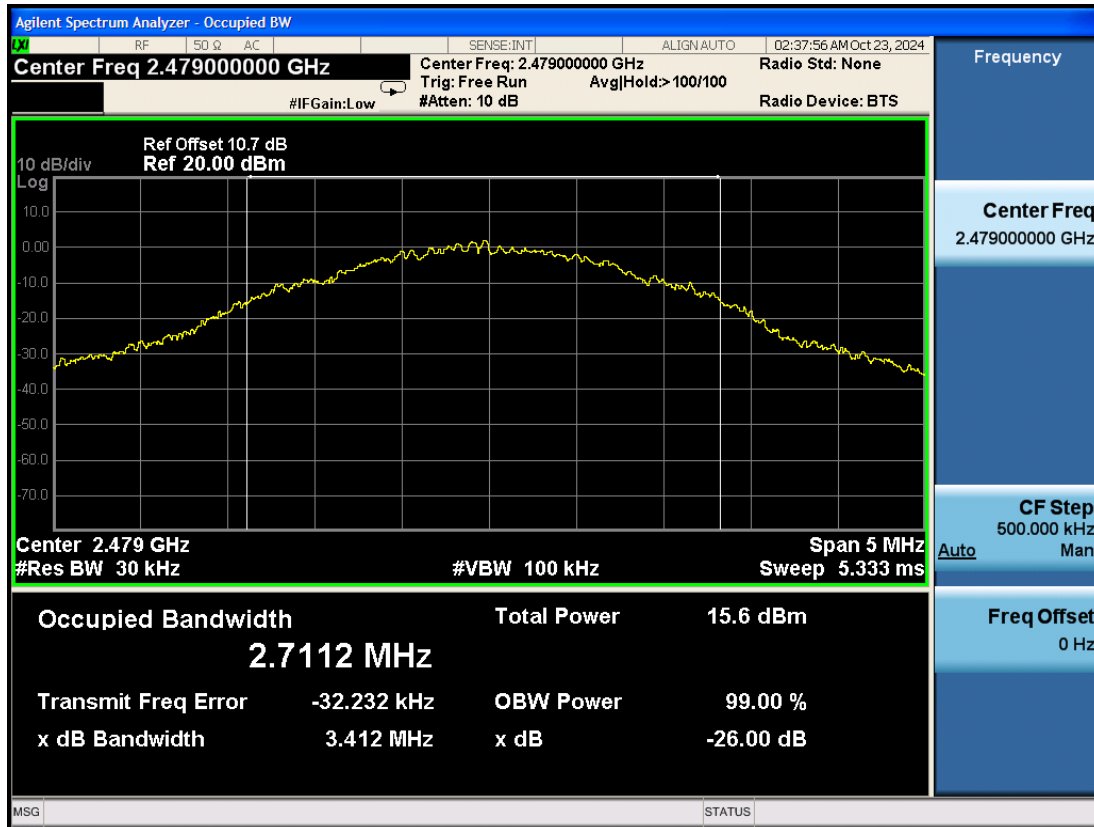

8. OUTPUT POWER TEST

8.1. Test Equipment

Item	Equipment	Manufacturer	Model No.	Serial No.	Last Cal.	Cal. Interval
1.	PXA Signal Analyzer	Agilent	N9030A	MY51380221	Mar.16,24	1 Year
2.	RF Cable	Eastsheep	RM086-SMA/N-JJ-2000	NO.1	Jun.19,24	1 Year
3.	Attenuator(10dB)	Agilent	8491B	MY39269201	Mar.16,24	1 Year

8.2. Limit (FCC Part 15C 15.247 b(3))

For systems using digital modulation in the 2400—2483.5MHz, The Peak output Power shall not exceed 1W(30dBm), As an alternative to a peak power measurement, compliance with the one Watt limit can be based on a measurement of the maximum conducted output power. Maximum Conducted Output Power is defined as the total transmit power delivered to all antennas and antenna elements averaged across all symbols in the signaling alphabet when the transmitter is operating at its maximum power control level.

8.3. Test Procedure

- 1, Connected the EUT's antenna port to Spectrum Analyzer.
- 2, Use the test method described in ANSI C63.10 clause 11.9.1:
 - 1) Set the RBW \geq DTS bandwidth.
 - 2) Set VBW \geq [3 \times RBW].
 - 3) Set span \geq [3 \times RBW].
 - 4) Sweep time = auto couple.
 - 5) Detector = peak.
 - 6) Trace mode = max hold.
 - 7) Allow trace to fully stabilize.
 - 8) Use peak marker function to determine the peak amplitude level.
 - 9) For Peak output power: Connected the EUT's Antenna port to PXA signal analyzer.
For Average power: Connected the EUT's Antenna port to power meter.

Note: The cable loss and attenuator loss were offset into measure device as an amplitude offset.

8.4. Test Results

EUT: Active Subwoofer		
M/N: YY2088C2		
Test date:2024-09-06~24	Pressure: 102.1±1.0 kpa	Humidity: 51.1±3.0%
Tested by: Lili	Test site: RF site	Temperature:22.8±0.6 °C

ANT A

Test Mode	Frequency (MHz)	Power Setting	Peak Output Power (dBm)	Average Power (dBm) (Without Duty cycle Factor)	Duty cycle Factor	Average Power (dBm) (Add Duty cycle Factor)	Limit (dBm)
GFSK	2403	0X07 0XF9	6.313	6.050	0	6.050	30
	2441		7.105	6.854	0	6.854	
	2479		7.367	7.019	0	7.019	
Conclusion: PASS							
Remark: Duty cycle Factor=10*log(1/duty cycle)							

ANT B

Test Mode	Frequency (MHz)	Power Setting	Peak Output Power (dBm)	Average Power (dBm) (Without Duty cycle Factor)	Duty cycle Factor	Average Power (dBm) (Add Duty cycle Factor)	Limit (dBm)
GFSK	2403	0X07 0XF9	6.249	5.955	0	5.955	30
	2441		7.146	6.847	0	6.847	
	2479		7.051	6.740	0	6.740	
Conclusion: PASS							
Remark: Duty cycle Factor=10*log(1/duty cycle)							