

LOCALLY PROCURED PART
COUNTRY OF ORIGIN (THAILAND)

FOR SONY USE ONLY
LABEL TYPE
AVR-UC-2-001

WRITTEN LETTERS	LETTER HEIGHT	TYPE FACE
SONY®	L=13	SONY LOGOTYPE WITH®SYMBOL (NO.2)
MODEL :	1	NEW SONY ID TYPE HRC
XAV-AX8100	1.6	
AV RECEIVER		
MADE IN THAILAND	1	NEW SONY ID TYPE HRC
HECHO EN - THAILANDE		
DC:12 V - GROUND(10 A)		
(3 PORTIONS)	α=1	REFER TO DATA
SPEAKER-8 Ω X 4	1	NEW SONY ID TYPE HRC
USB: 5 V		
REM OUT: 12 V		
THIS DEVICE-OPERATION.	1.4	NEW SONY ID TYPE HRC
FCC ID:		
AK8XAVAX8100		
IC :	1.2	NEW SONY ID TYPE HR
409B-XAVAX8100		
SERIAL NO. (LABEL MODEL NUMBER)	1.4	
5-026-822-01	1.2	
SERIAL NO. (LABEL SERIAL)	3	
Serial Number (2 PORTIONS)		

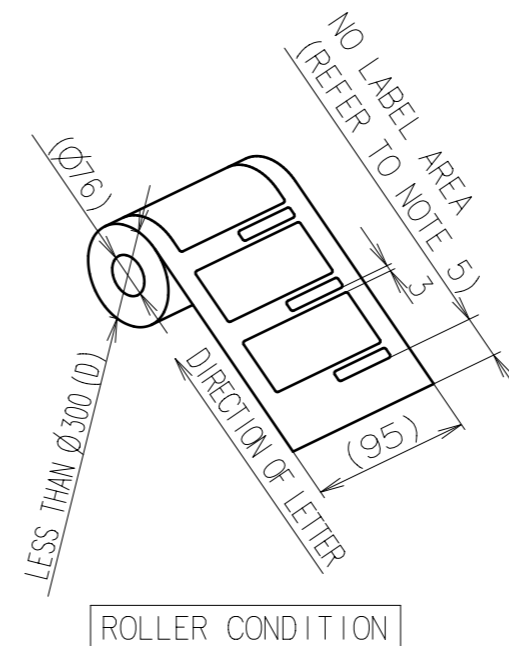
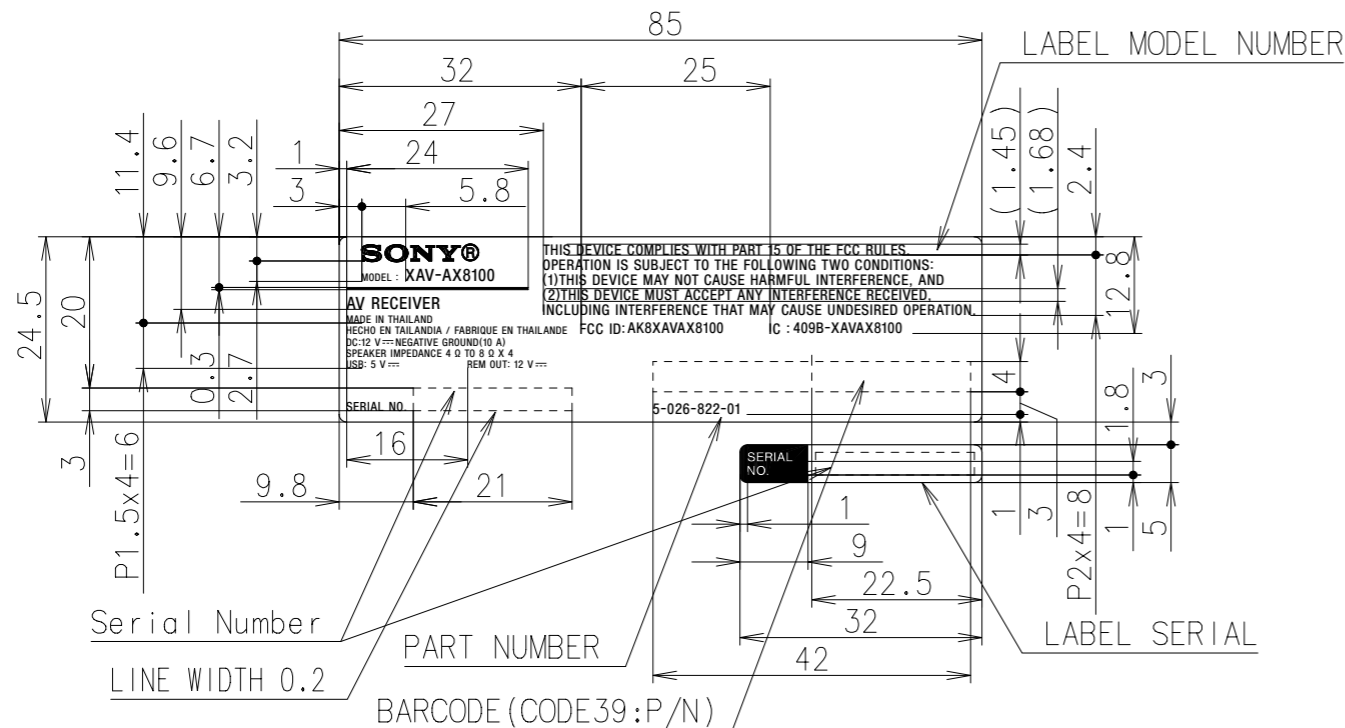

DRAWING

SONY STANDARD

MATERIAL CONSTRUCTION TABLE

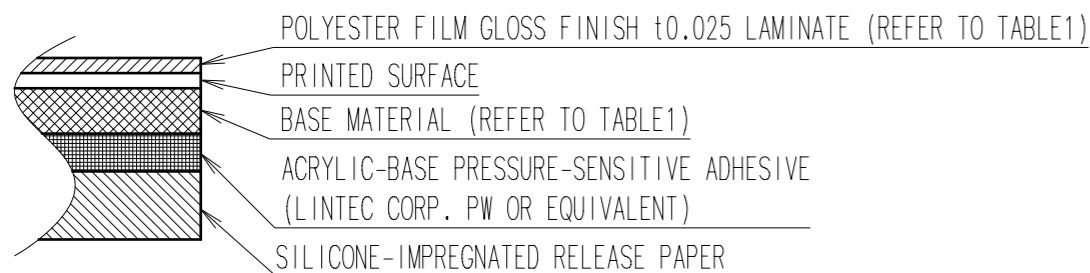

QUALITY CHARACTERISTICS:ALL THE SPECIFICATIONS IN SECTION 7.1 IN STM-1078 "LABELS AND NAMEPLATES-PARTS DESIGN STANDARDS" SHOULD BE SATISFIED.

- NOTE 1) THE ADDED Serial Number IS TO BE DETERMINED UNDER INSTRUCTIONS FROM THE MATERIAL SECTION OF ORDERING FACTORY.
- 2) POSITION OF Serial Number(REFER TO RIGHT) TOLERANCE OF SIZE MUST BE±0.5.
- 3) DELIVERY SHALL BE IN ROLLED CONDITION.
- 4) UNLESS OTHERWISE SPECIFIED,ROUNDING SHALL BE R1.
- 5) NO LABEL AREA MUST BE LONG ENOUGH TO COVER OUTSIDE SURFACE OF THE ROLLER(ØD).
- 6) BLOCK COPY PROVIDED FROM SONY SHOULD BE USED.

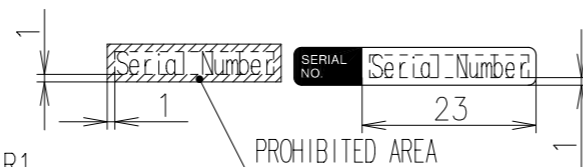

TABLE 1 : MATERIALS SPECIFICATION

ITEM	POLYESTER FILM		BASE MATERIAL	
	PRODUCT NAME	PARTNER	PRODUCT NAME	PARTNER
1	PET25 NPL 6LK	LINTEC	WOOD FREE PAPER	HPL-W THAI KK
2	OPP LAMINATING TAPE OPAT	KK ENTERPRISE	(70 g/m ²) SUPER VELLUM 70/ PP3C/ WG62	PMC

CHOOSE MATERIALS FROM THIS TABLE TO MAKE PART

Purchase recycled resins and wire rods only from the business partners that Sony approves as Green Partners.
再生樹脂・被覆電線はグリーンパートナー認定取引先から調達すること。

HISTORY X COUNT	SUFFIX /REV.NO. -REPL.	RELEASE NO. DATE	REVISION	SIGN.	GENERAL TOLERANCE	STANDARD	DATE OF ISSUE	
					REFER TO ABOVE	STY-3	2020.10.08	
						ISO 8015		
LEGAL OWNER Sony Corporation					MATERIAL (COLOR)	FINISH(COLOR)		
RESPONSIBLE DEPARTMENT AUTOMOTIVE BUSINESS DIV.					ORIGINAL MODEL XAV-AX8100/Q(UC)	DESCRIPTION (E) LABEL, MODEL NUMBER (UC)		
PLANNED BY 2020.10.08 S.ALISA					CHECKED BY STT 20.10.08 ALISA	APPROVED BY STT 20.10.08 TERAWAT	SCALE 1:1	
DRAWN BY 2020.10.08 P.THREERAWICH					PRJ. METHOD 	SIZE UNIT A3 mm	TENTATIVE MODEL SK-3195	
					PART NO.	SUFFIX	REV.NO.	SHEET/PAGES
					5026822	01	A	1 / 1

THIS DOCUMENT IS THE PROPRIETARY PROPERTY OF SONY. ITS USE IS AUTHORIZED ONLY FOR RESPONDING TO A REQUEST FOR QUOTATION, OR FOR THE PERFORMANCE OF WORK FOR SONY. ALL QUESTIONS MUST BE REFERRED TO THE LOCAL PURCHASING DEPARTMENT OF SONY. THIS PART SHOULD NOT CONTAIN ANY SUBSTANCES WHICH ARE SPECIFIED IN SS-00259-01. THE REPRODUCTION, DISTRIBUTION AND UTILIZATION OF THIS DOCUMENT AS WELL AS THE COMMUNICATION OF ITS CONTENTS TO OTHERS WITHOUT EXPRESS AUTHORIZATION IS PROHIBITED. OFFENDERS WILL BE HELD LIABLE FOR THE PAYMENT OF DAMAGES. ALL RIGHTS RESERVED IN THE EVENT OF THE GRANT OF A PATENT, UTILITY MODEL OR DESIGN. COPYRIGHT RESERVED.

PLACEMENT OF APPROVAL MARK AND SERIAL NUMBER MODEL: XAV-AX8100//Q(UC)

Type Approval mark label and serial number is to be printed are on the same plate label affixed to bottom of main unit

