



RADIO TEST REPORT

Test Report No. : 12327685S-A

Applicant : Sony Corporation, Japan and Sony Group Companies
Type of Equipment : AV RECEIVER
Model No. : XAV-AX3000
FCC ID : AK8XAVAX3000
Test regulation : FCC Part 15 Subpart C: 2018
Test Result : Complied

1. This test report shall not be reproduced in full or partial, without the written approval of UL Japan, Inc.
2. The results in this report apply only to the sample tested.
3. This sample tested is in compliance with the limits of the above regulation.
4. The test results in this test report are traceable to the national or international standards.
5. This test report must not be used by the customer to claim product certification, approval, or endorsement by any agency of the Federal Government.
6. This test report covers EMC technical requirements.
It does not cover administrative issues such as Manual or non-EMC test related Requirements. (if applicable)
7. The all test items in this test report are conducted by UL Japan, Inc. Shonan EMC Lab.
8. The opinions and the interpretations to the result of the description in this report are outside scopes where UL Japan has been accredited.

Date of test: May 24 to 27, 2018

Representative test engineer: 
Yosuke Ishikawa
Engineer
Consumer Technology Division

Approved by: 
Akio Hayashi
Leader
Consumer Technology Division



- The testing in which "Non-accreditation" is displayed is outside the accreditation scopes in UL Japan.
 There is no testing item of "Non-accreditation".

UL Japan, Inc.
Shonan EMC Lab.

1-22-3 Megumigaoka, Hiratsuka-shi, Kanagawa-ken, 259-1220 JAPAN
Telephone : +81 463 50 6400
Facsimile : +81 463 50 6401

CONTENTS	PAGE
SECTION 1: Customer information	4
SECTION 2: Equipment under test (E.U.T.)	4
SECTION 3: Test specification, procedures & results	5
SECTION 4: Operation of E.U.T. during testing.....	8
SECTION 5: Radiated Spurious Emission	11
SECTION 6: Antenna Terminal Conducted Tests	12
APPENDIX 1: Test data	13
20 dB Bandwidth, 99 % Occupied Bandwidth and Carrier Frequency Separation.....	13
Number of Hopping Frequency	17
Dwell time.....	19
Maximum Peak Output Power	22
Average Output Power.....	23
Radiated Spurious Emission	25
Conducted Spurious Emission	36
Conducted Emission Band Edge compliance.....	42
APPENDIX 2: Test instruments	44
APPENDIX 3: Photographs of test setup.....	45
Radiated Spurious Emission	45

SECTION 1: Customer information

Company Name : Sony Corporation, Japan and Sony Group Companies
Address : 1-7-1 Konan Minato-ku Tokyo, 108-0075 Japan
Telephone Number : +66 38 214900 17 Ext : 1932
Contact Person : Jumroen Phaoenchoke

SECTION 2: Equipment under test (E.U.T.)

2.1 Identification of E.U.T.

Type of Equipment : AV RECEIVER
Model No. : XAV-AX3000
Serial No. : Refer to Section 4, Clause 4.2
Rating : DC 12 V
Receipt Date of Sample : April 25, 2018
Country of Mass-production : Thailand
Condition of EUT : Engineering prototype
(Not for Sale: This sample is equivalent to mass-produced items.)
Modification of EUT : No Modification by the test lab

2.2 Product Description

Model: XAV-AX3000 (referred to as the EUT in this report) is an AV RECEIVER.

Radio Specification

Bluetooth

Radio Type : Transceiver
Frequency of Operation : 2402 MHz - 2480 MHz
Modulation : FHSS, GFSK, $\pi/4$ -DQPSK, 8DPSK
Antenna type : Meander Monopole antenna
Antenna Gain : -0.63 dBi
Clock frequency (Maximum) : 26 MHz (Crystal)

SECTION 3: Test specification, procedures & results

3.1 Test Specification

Test Specification : FCC Part 15 Subpart C
FCC Part 15 final revised on March 12, 2018 and effective April 11, 2018

Title : FCC 47CFR Part15 Radio Frequency Device Subpart C Intentional Radiators
Section 15.207 Conducted limits
Section 15.247 Operation within the bands 902-928MHz,
2400-2483.5MHz, and 5725-5850MHz

3.2 Procedures and results

Item	Procedure	Specification	Worst Margin	Results	Remarks
Conducted Emission	FCC: ANSI C63.10-2013 6. Standard test methods IC: RSS-Gen 8.8	FCC: Section 15.207 IC: RSS-Gen 8.8	N/A	N/A	N/A *1)
Carrier Frequency Separation	FCC: FCC Public Notice DA 00-705 IC: -	FCC: Section15.247(a)(1) IC: RSS-247 5.1 (b)	See data.	Complied	Conducted
20 dB Bandwidth	FCC: FCC Public Notice DA 00-705 IC: -	FCC: Section15.247(a)(1) IC: RSS-247 5.1 (a)		Complied	Conducted
Number of Hopping Frequency	FCC: FCC Public Notice DA 00-705 IC: -	FCC: Section15.247(a)(1)(iii) IC: RSS-247 5.1 (d)		Complied	Conducted
Dwell time	FCC: FCC Public Notice DA 00-705 IC: -	FCC: Section15.247(a)(1)(iii) IC: RSS-247 5.1 (d)		Complied	Conducted
Maximum Peak Output Power	FCC: FCC Public Notice DA 00-705 IC: RSS-Gen 6.12	FCC: Section15.247(a)(b)(1) IC: RSS-247 5.4 (b)		Complied	Conducted
Spurious Emission & Band Edge Compliance	FCC: FCC Public Notice DA 00-705 IC: RSS-Gen 6.13	FCC: Section15.247(d) IC: RSS-247 5.5 RSS-Gen 8.9 RSS-Gen 8.10		1.5 dB 432.000 MHz, QP, Hori, Tx, DH5 2402 MHz	Complied#

Note: UL Japan, Inc.'s EMI Work Procedures No. 13-EM-W0420 and 13-EM-W0422.

*1) The test is not applicable since the EUT does not have AC power ports.

*2) Radiated test was selected over 30 MHz based on section 15.247(d).

Symbols:

Complied The data of this test item has enough margin, more than the measurement uncertainty.

Complied# The data of this test item meets the limits unless the measurement uncertainty is taken into consideration.

* In case any questions arise about test procedure, ANSI C63.10: 2013 is also referred.

FCC Part 15.31 (e)

The EUT provides stable voltage constantly to the wireless transmitter regardless of input voltage.

Instead of a new battery, DC power supply was used for the test. That does not affect the test result, therefore the EUT complies with the requirement.

FCC Part 15.203 Antenna requirement

It is impossible for end users to replace the antenna, because the antenna is mounted inside of the EUT. Therefore, the equipment complies with the antenna requirement.

UL Japan, Inc.

Shonan EMC Lab.

1-22-3 Megumigaoka, Hiratsuka-shi, Kanagawa-ken, 259-1220 JAPAN

Telephone : +81 463 50 6400

Facsimile : +81 463 50 6401

3.3 Addition to standard

Item	Test Procedure	Specification	Worst margin	Results	Remarks
99 % Occupied Bandwidth	IC: RSS-Gen 6.6	IC: -	N/A	Complied	Conducted
Symbols:					
Complied		The data of this test item has enough margin, more than the measurement uncertainty.			
Complied#		The data of this test item meets the limits unless the measurement uncertainty is taken into consideration.			

Other than above, no addition, exclusion nor deviation has been made from the standard.

3.4 Uncertainty

EMI

The following uncertainties have been calculated to provide a confidence level of 95 % using a coverage factor $k=2$.
Shonan EMC Lab.

Item	Frequency range	Uncertainty (+/-)				
		No. 1 SAC / SR	No. 2 SAC / SR	No. 3 SAC / SR	No. 4 SAC / SR	No. 5,6,8 SR
Conducted emission (AC Mains) LISN	150 kHz-30 MHz	2.5 dB	2.5 dB	2.5 dB	2.6 dB	2.6 dB
Radiated emission (Measurement distance: 3 m)	9 kHz-30 MHz	3.2 dB	3.2 dB	3.3 dB	-	-
	30 MHz-200 MHz	4.3 dB	4.3 dB	4.3 dB	-	-
	200 MHz-1 GHz	5.9 dB	5.9 dB	5.9 dB	-	-
	1 GHz-6 GHz	4.7 dB	4.7 dB	4.7 dB	-	-
	6 GHz-18 GHz	5.3 dB	5.3 dB	5.3 dB	-	-
	18 GHz-40 GHz	5.6 dB	5.6 dB	5.6 dB	-	-
Radiated emission (Measurement distance: 1 m)	1 GHz-18 GHz	5.6 dB	5.6 dB	5.6 dB	-	-
	18 GHz-40 GHz	5.9 dB	5.9 dB	5.9 dB	-	-

SAC=Semi-Anechoic Chamber

SR= Shielded Room is applied besides radiated emission

Antenna terminal test	Uncertainty (+/-)
Power Measurement above 1 GHz (Average Detector)_SPM-06	0.48 dB
Power Measurement above 1 GHz (Peak Detector)_SPM-06	0.66 dB
Power Measurement above 1 GHz (Average Detector)_SPM-07	0.47 dB
Power Measurement above 1 GHz (Peak Detector)_SPM-07	0.64 dB
Spurious emission (Conducted) below 1GHz	1.8 dB
Spurious emission (Conducted) 1 GHz-3 GHz	1.7 dB
Spurious emission (Conducted) 3 GHz-18 GHz	2.5 dB
Spurious emission (Conducted) 18 GHz-26.5 GHz	2.5 dB
Spurious emission (Conducted) 26.5 GHz-40 GHz	2.7 dB
Bandwidth Measurement	1.01 %
Duty cycle and Time Measurement	0.012 %

3.5 Test Location

UL Japan, Inc. Shonan EMC Lab.
1-22-3, Megumigaoka, Hiratsuka-shi, Kanagawa-ken 259-1220 JAPAN
Telephone: +81 463 50 6400, Facsimile: +81 463 50 6401
JAB Accreditation No. RTL02610
FCC Test Firm Registration Number: 839876

Test site	IC Registration Number	Width x Depth x Height (m)	Size of reference ground plane (m) / horizontal conducting plane	Maximum measurement distance
No.1 Semi-anechoic chamber	2973D-1	20.6 x 11.3 x 7.65	20.6 x 11.3	10 m
No.2 Semi-anechoic chamber	2973D-2	20.6 x 11.3 x 7.65	20.6 x 11.3	10 m
No.3 Semi-anechoic chamber	2973D-3	12.7 x 7.7 x 5.35	12.7 x 7.7	5 m
No.4 Semi-anechoic chamber	-	8.1 x 5.1 x 3.55	8.1 x 5.1	-
No.1 Shielded room	-	6.8 x 4.1 x 2.7	6.8 x 4.1	-
No.2 Shielded room	-	6.8 x 4.1 x 2.7	6.8 x 4.1	-
No.3 Shielded room	-	6.3 x 4.7 x 2.7	6.3 x 4.7	-
No.4 Shielded room	-	4.4 x 4.7 x 2.7	4.4 x 4.7	-
No.5 Shielded room	-	7.8 x 6.4 x 2.7	7.8 x 6.4	-
No.6 Shielded room	-	7.8 x 6.4 x 2.7	7.8 x 6.4	-
No.8 shielded room	-	3.45 x 5.5 x 2.4	3.45 x 5.5	-
No.1 Measurement room	-	2.55 x 4.1 x 2.5	-	-

3.6 Test data, Test instruments, and Test set up

Refer to APPENDIX.

SECTION 4: Operation of E.U.T. during testing

4.1 Operating Mode(s)

Bluetooth (BT): Transmitting (Tx), Payload: PRBS9

Details of Operating Mode(s)

Test Item	Mode	Tested frequency
Conducted Emission, Spurious Emission (Radiated)	Tx (Hopping Off) DH5, 3DH5	2402 MHz 2441 MHz 2480 MHz
Carrier Frequency Separation	Tx (Hopping On) DH5, 3DH5	2402 MHz 2441 MHz 2480 MHz
20 dB Bandwidth	Tx (Hopping Off) DH5, 3DH5	2402 MHz 2441 MHz 2480 MHz
Number of Hopping Frequency	Tx (Hopping On) DH5, 3DH5	-
Dwell time	Tx (Hopping On), -DH1, DH3, DH5 -3DH1, 3DH3, 3DH5	-
Maximum Peak Output Power	Tx (Hopping Off) DH5, 2DH5, 3DH5	2402 MHz 2441 MHz 2480 MHz
Band Edge Compliance (Conducted)	Tx DH5, 3DH5 -Hopping On -Hopping Off	2402 MHz 2480 MHz
99 % Occupied Bandwidth	Tx DH5, 3DH5 -Hopping On -Hopping Off	2402 MHz 2441 MHz 2480 MHz
<p>*As a result of preliminary test, the formal test was performed with the above modes, which had the maximum payload length (except Dwell time test)</p> <p>*2DH mode (2Mb/s EDR: pi/4DQPSK) was excluded for other tests than power measurement by using 3DH mode (3 Mb/s EDR: 8DPSK) as a representative.</p> <p>* It is considered that the non-tested packet type (e.g. inquiry) can be omitted as it is complied with above all the test items based on Bluetooth Core specification.</p> <p>*EUT has the power settings by the software as follows; Power settings: BDR: Ext.=23, Int.=39 EDR: Ext.=72, Int.=48 Software: CSR BlueSuite BlueTest Version 2.6.6 *This setting of software is the worst case. Any conditions under the normal use do not exceed the condition of setting. In addition, end users cannot change the settings of the output power of the product.</p>		

4.2 Configuration and peripherals

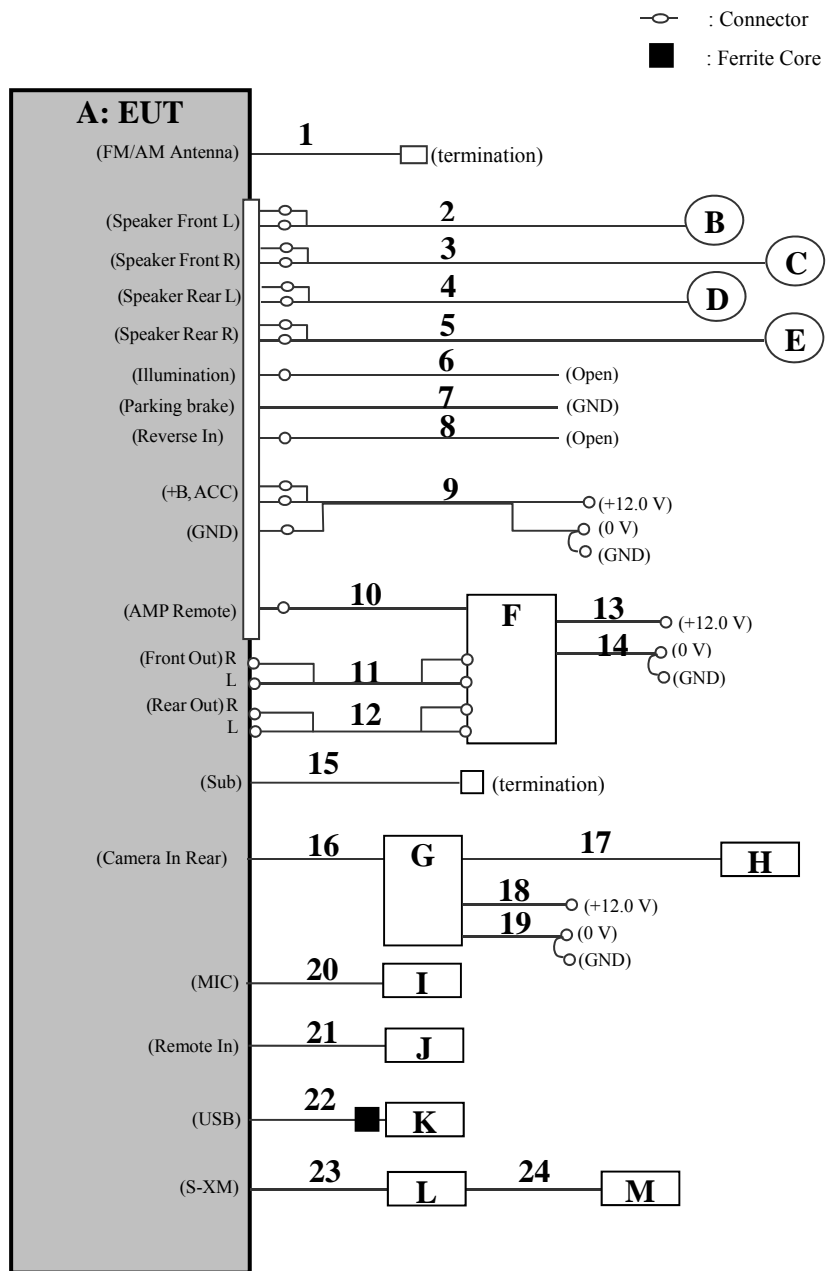

* Cabling and setup were taken into consideration and test data was taken under worse case conditions

Description of EUT and support equipment

No.	Item	Model number	Serial number	Manufacturer	Remarks
A	AV Receiver	XAV-AX3000	097	Sony	EUT
B	Speaker 1	IS-10	-	Sony	-
C	Speaker 2	IS-10	-	Sony	-
D	Speaker 3	XS-GTF1625R	-	Sony	-
E	Speaker 4	XS-GTF1625R	-	Sony	-
F	Stereo Power Amplifier	XM-4S-020	SoC5	Sony	-
G	Rear View Camera	XA-R800C	100114	Sony	-
H	Camera	-	-	Sony	-
I	MIC	-	-	Sony	-
J	Wired Remote Controller	RM-X4S	-	Sony	-
K	USB Memory	SDK-USM4GL(B)	10615MEDB	Sony	-
L	Vehicle Tuner	SXV300	1VH90D08	Sirius XM Radio Inc.	-
M	Antenna	NGVA3	1624A	Sirius XM Radio Inc.	-

List of cables used

No.	Name	Length (m)	Shield (Cable)	Shield (Connector)	Remarks
1	FM antenna	1.0	Shielded	Shielded	-
2	Speaker (1)	0.15+2.4	Unshielded	Unshielded	-
3	Speaker (2)	0.15+2.4	Unshielded	Unshielded	-
4	Speaker (3)	0.15+1.9	Unshielded	Unshielded	-
5	Speaker (4)	0.15+1.9	Unshielded	Unshielded	-
6	Illumination	0.15+1.0	Unshielded	Unshielded	-
7	Parking	2.0	Unshielded	Unshielded	-
8	Reverse In	0.15+1.0	Unshielded	Unshielded	-
9	DC Power	0.15+1.3	Unshielded	Unshielded	-
10	AMP Remote	0.15+1.4	Unshielded	Unshielded	-
11	RCA (Front Audio Out)	5.0	Shielded	Shielded	-
12	RCA (Rear Audio Out)	5.0	Shielded	Shielded	-
13	DC Power (+)	1.3	Unshielded	Unshielded	-
14	DC Power (-)	1.3	Unshielded	Unshielded	-
15	RCA (Sub Audio Out)	1.0	Shielded	Shielded	-
16	RCA (Rear Camera)	3.0	Shielded	Shielded	-
17	Camera	3.0	Shielded	Shielded	-
18	DC Power (+)	0.9	Unshielded	Unshielded	-
19	DC Power (-)	0.9	Unshielded	Unshielded	-
20	MIC	3.5	Shielded	Shielded	-
21	REMOTE IN	2.0	Shielded	Shielded	-
22	USB	1.5	Shielded	Shielded	-
23	Sirius Tuner	0.6	Shielded	Shielded	-
24	Sirius Antenna	7.0	Shielded	Shielded	-

UL Japan, Inc.

Shonan EMC Lab.

1-22-3 Megumigaoka, Hiratsuka-shi, Kanagawa-ken, 259-1220 JAPAN

Telephone : +81 463 50 6400

Facsimile : +81 463 50 6401

SECTION 5: Radiated Spurious Emission

Test Procedure

[For below 1 GHz]

EUT was placed on a urethane platform of nominal size, 0.5 m by 1.0 m, raised 0.8 m above the conducting ground plane. The Radiated Electric Field Strength has been measured in a Semi Anechoic Chamber with a ground plane.

[For above 1 GHz]

EUT was placed on a urethane platform of nominal size, 0.5 m by 0.5 m, raised 1.5 m above the conducting ground plane.

The Radiated Electric Field Strength has been measured in a Semi Anechoic Chamber with absorbent materials lined on a ground plane.

The height of the measuring antenna varied between 1 and 4 m and EUT was rotated a full revolution in order to obtain the maximum value of the electric field strength.

The measurements were performed for both vertical and horizontal antenna polarization with the Test Receiver, or the Spectrum Analyzer.

The measurements were made with the following detector function of the test receiver and the Spectrum analyzer (in linear mode).

The test was made with the detector (RBW/VBW) in the following table.

When using Spectrum analyzer, the test was made with adjusting span to zero by using peak hold.

Test Antennas are used as below;

Frequency	30 MHz to 200 MHz	200 MHz to 1 GHz	Above 1 GHz
Antenna Type	Biconical	Logperiodic	Horn

In any 100 kHz bandwidth outside the restricted band in which the spread spectrum intentional radiator is operating, the radio frequency power that is produced by the intentional radiator confirmed 20 dB below that in the 100 kHz bandwidth within the band that contains the highest level of the desired power, based on a radiated measurement.

20 dBc was applied to the frequency over the limit of FCC 15.209 / Table 4 of RSS-Gen 8.9 (IC) and outside the restricted band of FCC15.205 / Table 6 of RSS-Gen 8.10 (IC).

Frequency	Below 1 GHz	Above 1 GHz		20 dBc
Instrument used	Test Receiver	Spectrum Analyzer		Spectrum Analyzer
Detector	QP	PK	AV	PK
IF Bandwidth	BW 120 kHz	RBW: 1 MHz VBW: 3 MHz	RBW: 1 MHz VBW: 10 Hz *1)	RBW: 100 kHz VBW: 300 kHz
Test Distance	3 m	3.9 m*2) (1 GHz – 13 GHz), 1 m*3) (13 GHz – 26.5 GHz)		3.9 m*2) (1 GHz – 13 GHz), 1 m*3) (13 GHz – 26.5 GHz)

*1) Although DA 00-705 accepts VBW = 10 Hz for AV measurements, it was confirmed that superfluous smoothing was not performed.

*2) Distance Factor: $20 \times \log(3.9 \text{ m}/3.0 \text{ m}) = 2.28 \text{ dB}$

*3) Distance Factor: $20 \times \log(1.0 \text{ m}/3.0 \text{ m}) = -9.54 \text{ dB}$

- The carrier level and noise levels were confirmed at each position of 0 deg. and 30 deg. of EUT to see the position of maximum noise, and the test was made at the position that has the maximum noise.

Combinations of the worst case

Antenna polarization	Frequency	Spurious		
		Below 1 GHz	1 GHz – 2.8 GHz	Above 2.8 GHz
Horizontal		0 deg.	0 deg.	30 deg.
Vertical		0 deg.	30 deg.	30 deg.

The test results and limit are rounded off to one decimal place, so some differences might be observed.

Measurement range : 30 MHz - 26.5 GHz

Test data : APPENDIX

Test result : Pass

UL Japan, Inc.

Shonan EMC Lab.

1-22-3 Megumigaoka, Hiratsuka-shi, Kanagawa-ken, 259-1220 JAPAN

Telephone : +81 463 50 6400

Facsimile : +81 463 50 6401

SECTION 6: Antenna Terminal Conducted Tests

Test Procedure

The tests were made with below setting connected to the antenna port.

Test	Span	RBW	VBW	Sweep time	Detector	Trace	Instrument used
20 dB Bandwidth	3 MHz	30 kHz	100 kHz	Auto	Peak	Max Hold	Spectrum Analyzer
99 % Occupied Bandwidth *1)	Enough width to display emission skirts	1 to 5 % of OBW	Three times of RBW	Auto	Peak	Max Hold	Spectrum Analyzer
Maximum Peak Output Power	-	-	-	Auto	Peak Average *2)	-	Power Meter (Sensor: 160 MHz BW)
Carrier Frequency Separation	3 MHz	100 kHz	300 kHz	Auto	Peak	Max Hold	Spectrum Analyzer
Number of Hopping Frequency	30 MHz	300 kHz	1 MHz	Auto	Peak	Max Hold	Spectrum Analyzer
Dwell Time	Zero Span	100 kHz, 1 MHz	300 kHz, 3 MHz	As necessary capture the entire dwell time per hopping channel	Peak	Clear Write	Spectrum Analyzer
Conducted Spurious Emission *3)	9 kHz to 150 kHz	200 Hz	620 Hz	Auto	Peak	Max Hold	Spectrum Analyzer
	150 kHz to 30 MHz	10 kHz	30 kHz				
	30 MHz to 25 GHz	100 kHz	300 kHz				
Conducted Spurious Emission Band Edge compliance	10 MHz	100 kHz	300 kHz	Auto	Peak	Max Hold	Spectrum Analyzer
*1) Peak hold was applied as Worst-case measurement. *2) Reference data *3) In the frequency range below 30MHz, RBW was narrowed to separate the noise contents. Then, wide-band noise near the limit was checked separately, however the noise was not detected as shown in the chart. (9 kHz -150 kHz: RBW = 200 Hz, 150 kHz - 30 MHz: RBW = 10 kHz)							

The test results and limit are rounded off to two decimals place, so some differences might be observed.

Test data : APPENDIX
Test result : Pass

APPENDIX 1: Test data

20 dB Bandwidth, 99 % Occupied Bandwidth and Carrier Frequency Separation

Report No. 12327685S-A
Test place Shonan EMC Lab. No.6 Shielded Room
Date May 24, 2018
Temperature / Humidity 26 deg. C / 54 % RH
Engineer Yosuke Ishikawa
Mode Tx, Hopping Off, Tx, Hopping On

Mode	Freq. [MHz]	20 dB Bandwidth [MHz]	99 % Occupied Bandwidth [kHz]	Carrier Frequency Separation [MHz]	Limit for Carrier Frequency separation [MHz]
DH5	2402.0	0.957	875.5	1.000	>= 0.638
DH5	2441.0	0.961	863.1	1.000	>= 0.641
DH5	2480.0	0.958	860.5	1.000	>= 0.639
DH5	Hopping On	-	78463.4	-	-
3DH5	2402.0	1.292	1160.3	1.000	>= 0.861
3DH5	2441.0	1.286	1157.1	1.000	>= 0.858
3DH5	2480.0	1.290	1159.4	1.000	>= 0.860
3DH5	Hopping On	-	78540.3	-	-

Limit: Two-thirds of 20 dB Bandwidth or 25 kHz (whichever is greater).

No limit applies to 20 dB Bandwidth.

20 dB Bandwidth and 99 % Occupied Bandwidth

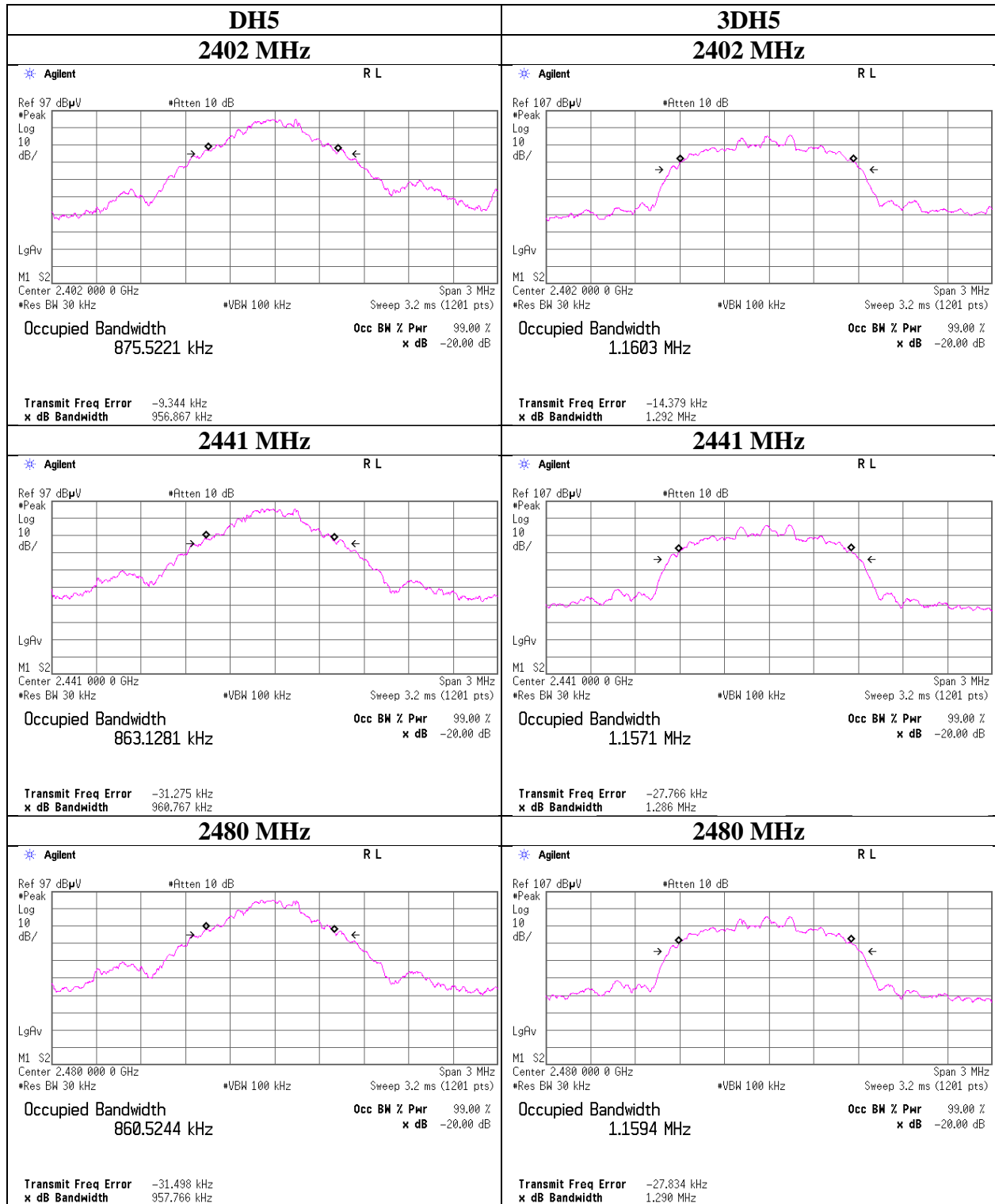

20 dB Bandwidth and 99 % Occupied Bandwidth

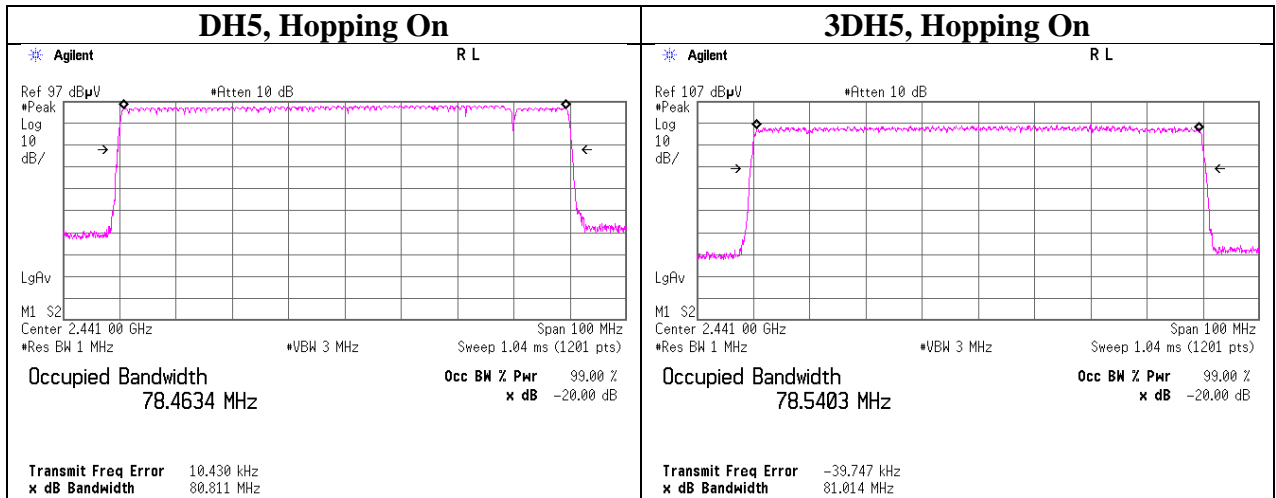

UL Japan, Inc.

Shonan EMC Lab.

1-22-3 Megumigaoka, Hiratsuka-shi, Kanagawa-ken, 259-1220 JAPAN

Telephone : +81 463 50 6400

Facsimile : +81 463 50 6401

Carrier Frequency Separation

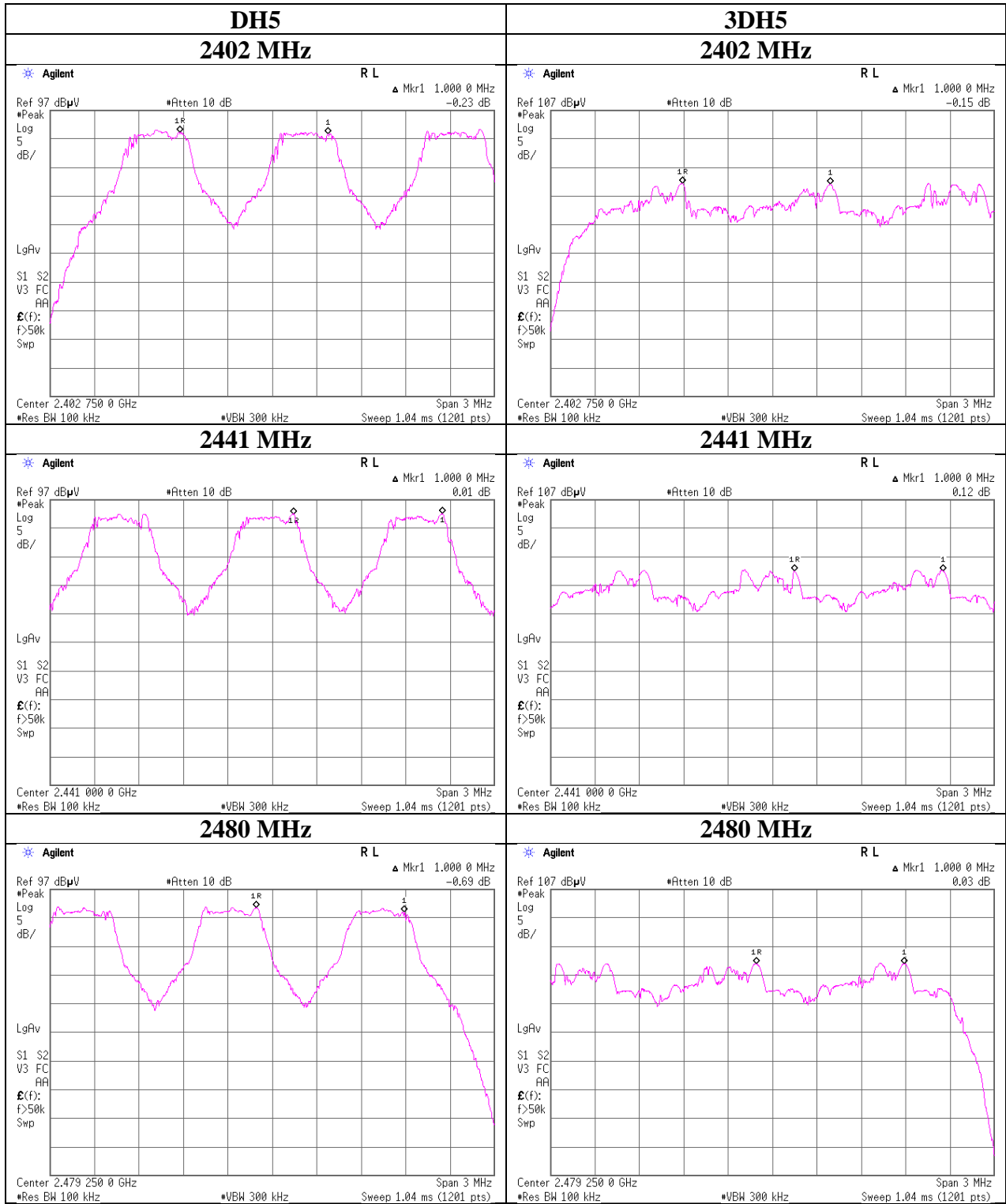

UL Japan, Inc.

Shonan EMC Lab.

1-22-3 Megumigaoka, Hiratsuka-shi, Kanagawa-ken, 259-1220 JAPAN

Telephone : +81 463 50 6400

Facsimile : +81 463 50 6401

Number of Hopping Frequency

Report No. 12327685S-A
Test place Shonan EMC Lab. No.6 Shielded Room
Date May 24, 2018
Temperature / Humidity 26 deg. C / 54 % RH
Engineer Yosuke Ishikawa
Mode Tx, Hopping On

Mode	Number of channel [channels]	Limit [channels]
DH5	79	>= 15
3DH5	79	>= 15

Test was not performed at AFH mode whose number of hopping channel is 20 channels because this Bluetooth radio is in compliance of Bluetooth Specification.

Number of Hopping Frequency

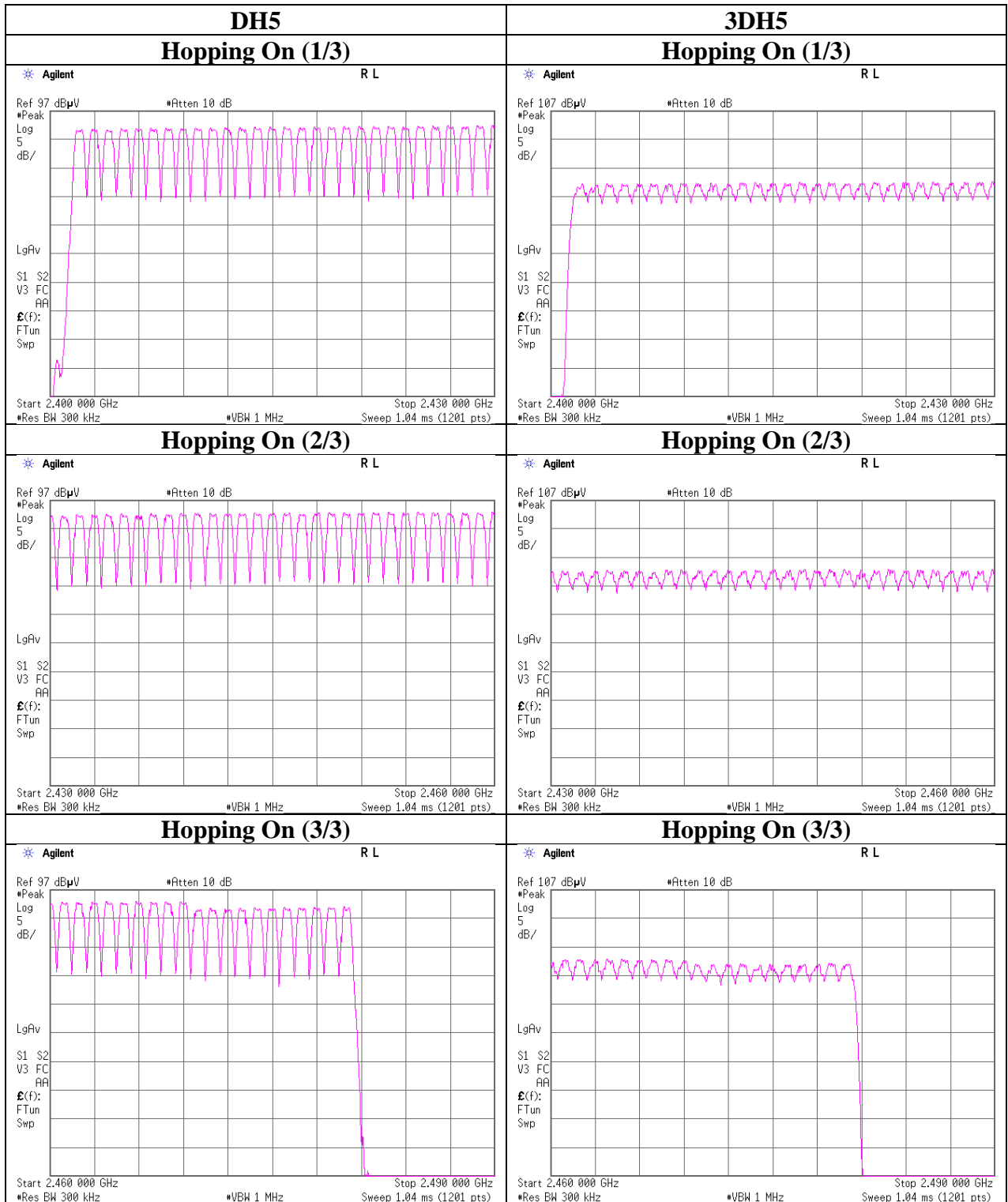

Dwell time

Report No. 12327685S-A
Test place Shonan EMC Lab. No.6 Shielded Room
Date May 24, 2018
Temperature / Humidity 26 deg. C / 54 % RH
Engineer Yosuke Ishikawa
Mode Tx, Hopping On

Mode	Number of transmission in a 31.6(79 Hopping x 0.4) / 12.8 (32 Hopping x 0.4) second period				Length of transmission [msec]	Result [msec]	Limit [msec]
DH1	16.6 times	/	5 sec.	x 31.6 sec. = 105 times	0.416	44	400
DH3	16.8 times	/	5 sec.	x 31.6 sec. = 107 times	1.675	179	400
DH5	16.6 times	/	5 sec.	x 31.6 sec. = 105 times	2.922	307	400
3DH1	16.8 times	/	5 sec.	x 31.6 sec. = 107 times	0.430	46	400
3DH3	16.6 times	/	5 sec.	x 31.6 sec. = 105 times	1.684	177	400
3DH5	16.8 times	/	5 sec.	x 31.6 sec. = 107 times	2.936	314	400

Sample Calculation

Result = Number of transmission x Length of transmission

*Average data of 5 tests.(except Inquiry)

Mode	Sampling [times]					Average [times]
	1	2	3	4	5	
DH1	17	16	16	17	17	16.6
DH3	16	17	17	17	17	16.8
DH5	17	16	17	17	16	16.6
3DH1	16	17	17	17	17	16.8
3DH3	16	16	17	17	17	16.6
3DH5	17	17	17	16	17	16.8

Sample Calculation

Average = Summation (Sampling 1 to 5) / 5

This device complies with the Bluetooth protocol for FHSS operation, employing a pseudo random channel selection and hopping rate to ensure that the occupancy time in $N \times 0.4s$, where N is the number of channels being used in the hopping sequence ($20 \leq N \leq 79$), is always less than $0.4s$ regardless of packet size. This is confirmed in the test report for $N = 79$.

Dwell time

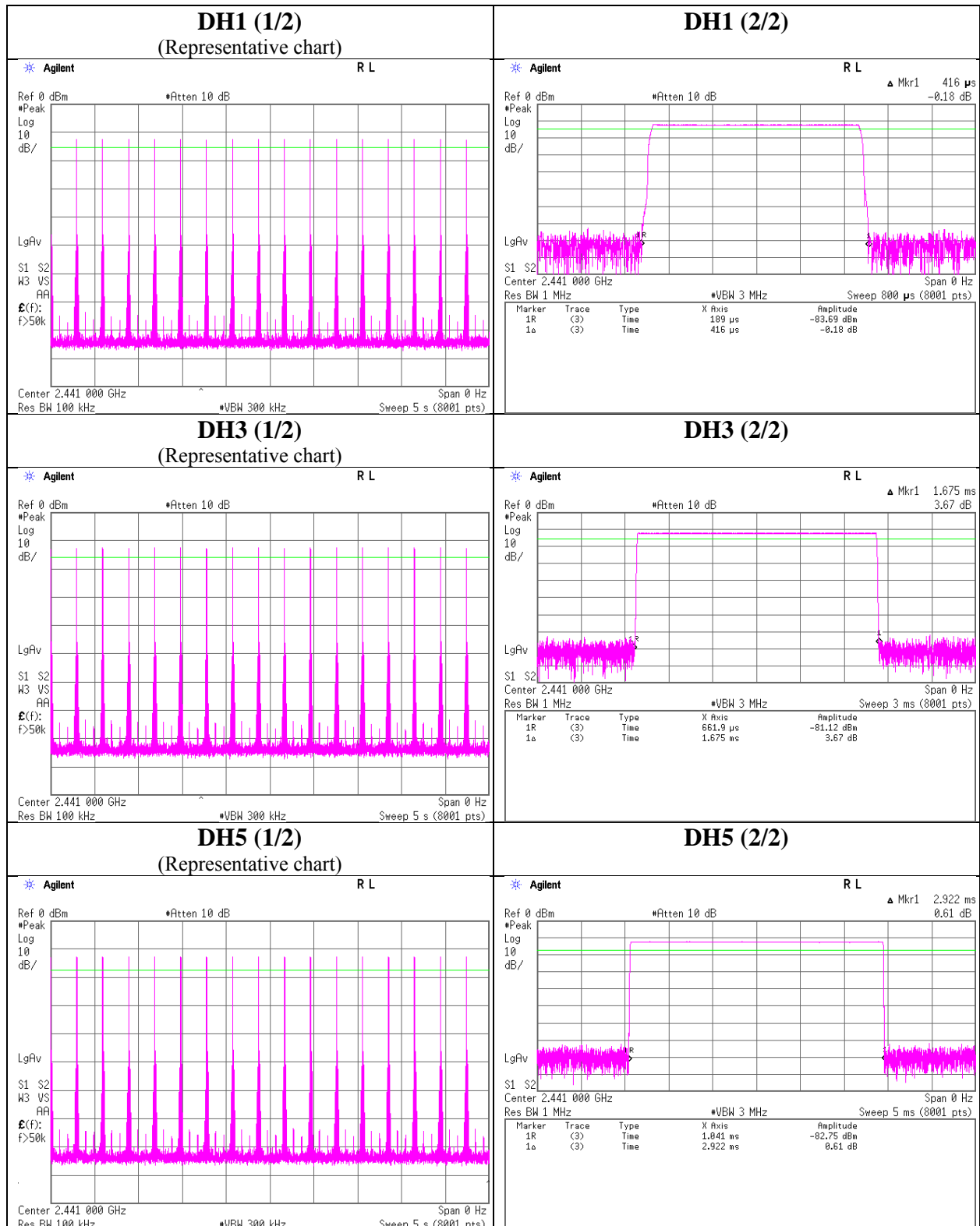

Dwell time

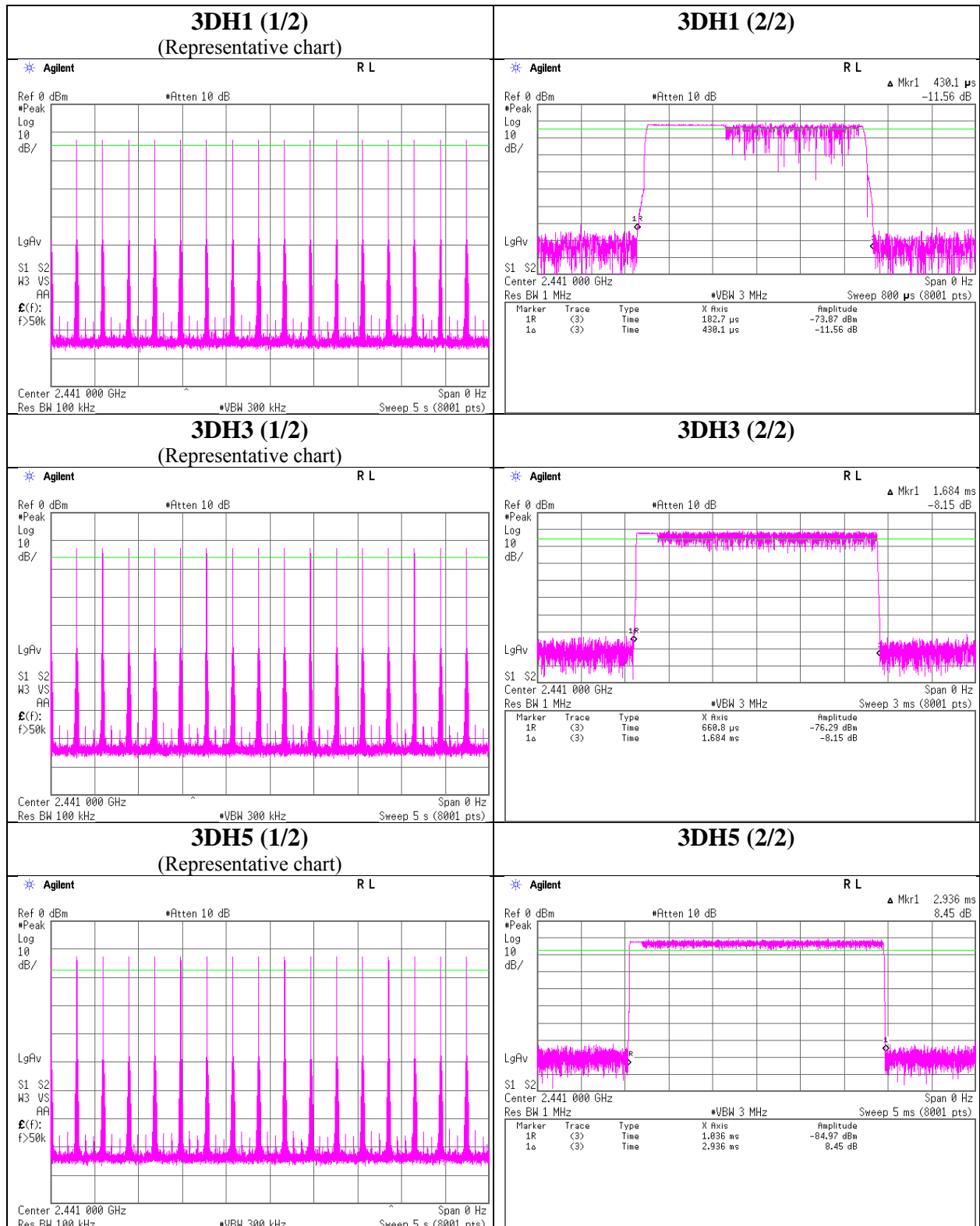

UL Japan, Inc.

Shonan EMC Lab.

1-22-3 Megumigaoka, Hiratsuka-shi, Kanagawa-ken, 259-1220 JAPAN

Telephone : +81 463 50 6400

Facsimile : +81 463 50 6401

Maximum Peak Output Power

Report No. 12327685S-A
Test place Shonan EMC Lab. No.6 Shielded Room
Date May 24, 2018
Temperature / Humidity 26 deg. C / 54 % RH
Engineer Yosuke Ishikawa
Mode Tx, Hopping Off

Mode	Freq. [MHz]	Reading [dBm]	Cable Loss [dB]	Atten. Loss [dB]	Conducted Power					e.i.r.p.					
					Result		Limit		Margin [dB]	Antenna Gain [dBi]	Result		Limit		Margin [dB]
					[dBm]	[mW]	[dBm]	[mW]			[dBm]	[mW]	[dBm]	[mW]	
DH5	2402.0	-12.61	1.69	9.88	-1.04	0.79	20.96	125	22.00	-0.63	-1.67	0.68	36.02	4000	37.69
DH5	2441.0	-11.82	1.70	9.88	-0.24	0.95	20.96	125	21.20	-0.63	-0.87	0.82	36.02	4000	36.89
DH5	2480.0	-12.47	1.72	9.88	-0.87	0.82	20.96	125	21.83	-0.63	-1.50	0.71	36.02	4000	37.52
2DH5	2402.0	-11.52	1.69	9.88	0.05	1.01	20.96	125	20.91	-0.63	-0.58	0.87	36.02	4000	36.60
2DH5	2441.0	-10.92	1.70	9.88	0.66	1.16	20.96	125	20.30	-0.63	0.03	1.01	36.02	4000	35.99
2DH5	2480.0	-11.49	1.72	9.88	0.11	1.03	20.96	125	20.85	-0.63	-0.52	0.89	36.02	4000	36.54
3DH5	2402.0	-11.03	1.69	9.88	0.54	1.13	20.96	125	20.42	-0.63	-0.09	0.98	36.02	4000	36.11
3DH5	2441.0	-10.41	1.70	9.88	1.17	1.31	20.96	125	19.79	-0.63	0.54	1.13	36.02	4000	35.48
3DH5	2480.0	-10.97	1.72	9.88	0.63	1.16	20.96	125	20.33	-0.63	0.00	1.00	36.02	4000	36.02

Sample Calculation:

Result = Reading + Cable Loss (including the cable(s) customer supplied) + Attenuator Loss

e.i.r.p. Result = Conducted Power Result + Antenna Gain

Test was not performed at AFH mode, because the decrease of number of channel (min: 20ch) at AFH mode does not influence on the output power and bandwidth of the EUT.

As this device had AFH mode and frequency separation could not meet the requirement of over 20dB BW without 2/3 relaxation, 125mW power limit was applied to it.

*e.i.r.p. data is reference data for FCC regulation.

UL Japan, Inc.

Shonan EMC Lab.

1-22-3 Megumigaoka, Hiratsuka-shi, Kanagawa-ken, 259-1220 JAPAN

Telephone : +81 463 50 6400

Facsimile : +81 463 50 6401

Average Output Power
(Reference data for RF Exposure / SAR testing)

Report No. 12327685S-A
Test place Shonan EMC Lab. No.6 Shielded Room
Date May 24, 2018
Temperature / Humidity 26 deg. C / 54 % RH
Engineer Yosuke Ishikawa
Mode Tx, Hopping Off

Mode	Freq. [MHz]	Reading [dBm]	Cable Loss [dB]	Atten. Loss [dB]	Result (Time average)		Duty factor [dB]	Result (Burst power average)	
					[dBm]	[mW]		[dBm]	[mW]
DH5	2402.0	-14.25	1.69	9.88	-2.68	0.54	1.08	-1.60	0.69
DH5	2441.0	-13.52	1.70	9.88	-1.94	0.64	1.08	-0.86	0.82
DH5	2480.0	-14.19	1.72	9.88	-2.59	0.55	1.08	-1.51	0.71
2DH5	2402.0	-15.22	1.69	9.88	-3.65	0.43	1.08	-2.57	0.55
2DH5	2441.0	-14.63	1.70	9.88	-3.05	0.50	1.08	-1.97	0.64
2DH5	2480.0	-15.18	1.72	9.88	-3.58	0.44	1.08	-2.50	0.56
3DH5	2402.0	-15.21	1.69	9.88	-3.64	0.43	1.08	-2.56	0.55
3DH5	2441.0	-14.63	1.70	9.88	-3.05	0.50	1.08	-1.97	0.64
3DH5	2480.0	-15.17	1.72	9.88	-3.57	0.44	1.08	-2.49	0.56

Sample Calculation:

Result (Time average) = Reading + Cable Loss (including the cable(s) customer supplied) + Attenuator Loss

Result (Burst power average) = Time average + Duty factor

*The equipment and cables were not used for factor 0 dB of the data sheets.

Burst Rate Confirmation

Report No. 12327685S-A
 Test place Shonan EMC Lab. No.6 Shielded Room
 Date May 24, 2018
 Temperature / Humidity 26 deg. C / 54 % RH
 Engineer Yosuke Ishikawa
 Mode Tx, Hopping Off

DH5

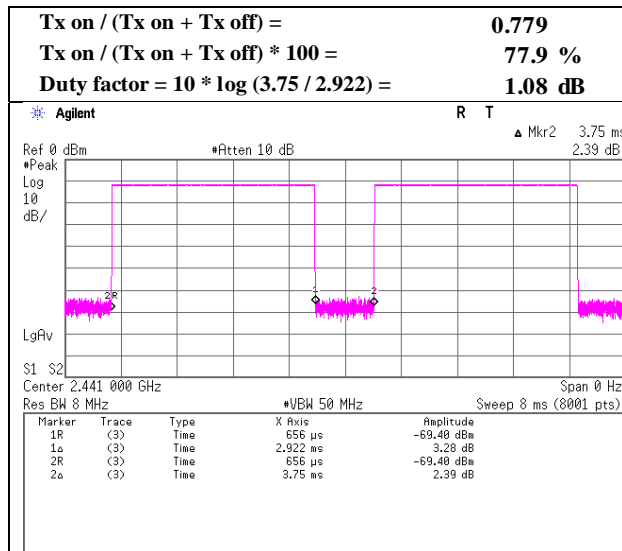

2DH5

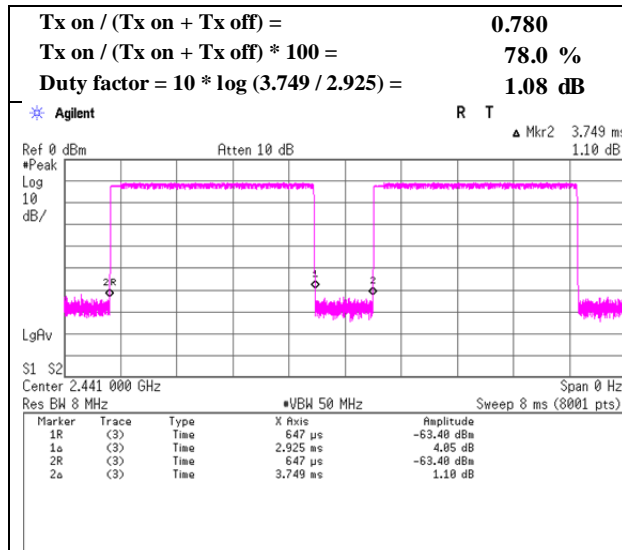

3DH5

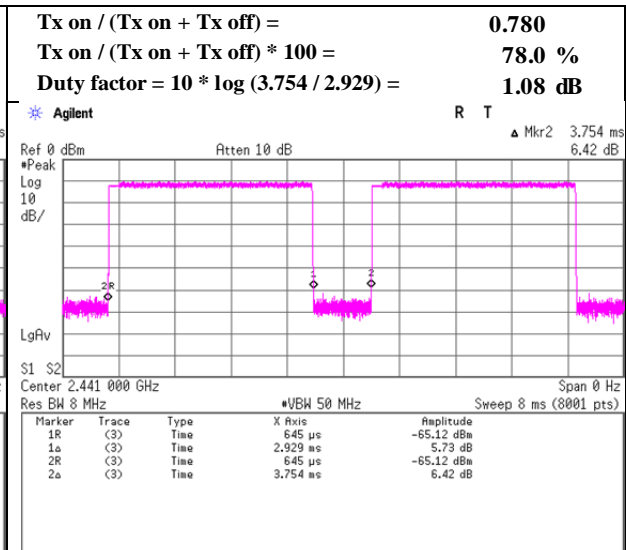

Radiated Spurious Emission

Report No. 12327685S-A
Test place Shonan EMC Lab.
Semi Anechoic Chamber No.2
Date May 26, 2018 May 27, 2018
Temperature / Humidity 23 deg.C / 53 %RH 24 deg.C / 56 %RH
Engineer Yosuke Ishikawa Kenichi Adachi
(30 MHz -2.8 GHz) (2.8 GHz -26.5 GHz)
Mode Tx, Hopping Off, DH5 2402 MHz

(* PK: Peak, AV: Average, QP: Quasi-Peak)

Polarity	Frequency [MHz]	Detector	Reading [dBuV]	Ant.Fac. [dB/m]	Loss [dB]	Gain [dB]	Distance Factor [dB]	Result [dBuV/m]	Limit [dBuV/m]	Margin [dB]	Height [cm]	Angle [deg]	Remark
Hori.	72.216	QP	46.72	6.22	7.50	31.90	0.00	28.54	40.00	11.5	239	239	
Hori.	74.769	QP	52.09	6.21	7.54	31.90	0.00	33.94	40.00	6.1	258	225	
Hori.	83.875	QP	54.38	6.94	7.66	31.89	0.00	37.09	40.00	2.9	233	38	
Hori.	94.555	QP	45.41	8.99	7.81	31.88	0.00	30.33	43.50	13.2	204	222	
Hori.	140.980	QP	46.45	14.39	8.35	31.84	0.00	37.35	43.50	6.2	224	236	
Hori.	432.000	QP	52.83	16.14	7.18	31.67	0.00	44.48	46.00	1.5	244	319	
Hori.	864.000	QP	43.01	21.40	8.95	31.07	0.00	42.29	46.00	3.7	100	201	
Hori.	2390.000	PK	49.47	27.16	13.31	44.13	2.28	48.09	73.90	25.8	146	134	
Hori.	3118.304	PK	52.73	28.63	5.71	44.23	2.28	45.12	73.90	28.8	139	119	
Hori.	4804.000	PK	53.82	31.14	6.62	44.45	2.28	49.41	73.90	24.5	152	168	
Hori.	7206.000	PK	47.73	36.48	7.76	43.99	2.28	50.26	73.90	23.6	150	0	
Hori.	9608.000	PK	48.36	38.20	8.69	43.83	2.28	53.70	73.90	20.2	150	0	
Hori.	12010.000	PK	48.58	39.06	10.45	43.36	2.28	57.01	73.90	16.9	150	0	
Hori.	2390.000	AV	36.77	27.16	13.31	44.13	2.28	35.39	53.90	18.5	146	134	
Hori.	3118.304	AV	43.19	28.63	5.71	44.23	2.28	35.58	53.90	18.3	139	119	
Hori.	4804.000	AV	45.37	31.14	6.62	44.45	2.28	40.96	53.90	12.9	152	168	
Hori.	7206.000	AV	36.16	36.48	7.76	43.99	2.28	38.69	53.90	15.2	150	0	
Hori.	9608.000	AV	37.24	38.20	8.69	43.83	2.28	42.58	53.90	11.3	150	0	
Hori.	12010.000	AV	36.53	39.06	10.45	43.36	2.28	44.96	53.90	8.9	150	0	
Vert.	95.564	QP	47.43	9.18	7.82	31.88	0.00	32.55	43.50	11.0	100	262	
Vert.	141.974	QP	44.82	14.44	8.36	31.84	0.00	35.78	43.50	7.7	100	209	
Vert.	432.000	QP	49.30	16.14	7.18	31.67	0.00	40.95	46.00	5.1	100	155	
Vert.	2390.000	PK	50.35	27.16	13.31	44.13	2.28	48.97	73.90	24.9	154	348	
Vert.	3118.304	PK	51.90	28.63	5.71	44.23	2.28	44.29	73.90	29.6	149	138	
Vert.	4804.000	PK	53.38	31.14	6.62	44.45	2.28	48.97	73.90	24.9	153	193	
Vert.	7206.000	PK	47.68	36.48	7.76	43.99	2.28	50.21	73.90	23.7	150	0	
Vert.	9608.000	PK	48.24	38.20	8.69	43.83	2.28	53.58	73.90	20.3	150	0	
Vert.	12010.000	PK	48.46	39.06	10.45	43.36	2.28	56.89	73.90	17.0	150	0	
Vert.	2390.000	AV	36.78	27.16	13.31	44.13	2.28	35.40	53.90	18.5	154	348	
Vert.	3118.304	AV	42.90	28.63	5.71	44.23	2.28	35.29	53.90	18.6	149	138	
Vert.	4804.000	AV	44.76	31.14	6.62	44.45	2.28	40.35	53.90	13.6	153	193	
Vert.	7206.000	AV	36.10	36.48	7.76	43.99	2.28	38.63	53.90	15.3	150	0	
Vert.	9608.000	AV	37.18	38.20	8.69	43.83	2.28	42.52	53.90	11.4	150	0	
Vert.	12010.000	AV	36.48	39.06	10.45	43.36	2.28	44.91	53.90	9.0	150	0	

Result = Reading + Ant.Fac. + Loss (Cable+(Attenuator or Filter)(below 18 GHz)) - Gain(Amplifier) + Distance factor

Distance factor : 1 GHz - 13 GHz : 20log(3.90 m / 3.0 m) = 2.28 dB

13 GHz - 40 GHz : 20log(1.0 m / 3.0 m) = -9.54 dB

* These results have sufficient margin without taking account Dwell time factor.

20 dBc Data Sheet (RBW 100 kHz, VBW 300 kHz)

Polarity	Frequency [MHz]	Detector	Reading [dBuV]	Ant.Fac. [dB/m]	Loss [dB]	Gain [dB]	Distance Factor [dB]	Result [dBuV/m]	Limit [dBuV/m]	Margin [dB]	Remark
Hori.	2402.000	PK	83.79	27.20	13.92	44.14	2.28	83.05	-	-	Carrier
Hori.	2400.000	PK	40.96	27.20	13.32	44.14	2.28	39.62	63.05	23.4	
Vert.	2402.000	PK	89.63	27.20	13.92	44.14	2.28	88.89	-	-	Carrier
Vert.	2400.000	PK	41.87	27.20	13.32	44.14	2.28	40.53	68.89	28.4	

Result = Reading + Ant.Fac. + Loss (Cable+(Attenuator or Filter)(below 18 GHz)) - Gain(Amplifier) + Distance factor

Distance factor : 1 GHz - 13 GHz : 20log(3.90 m / 3.0 m) = 2.28 dB

13 GHz - 40 GHz : 20log(1.0 m / 3.0 m) = -9.54 dB

UL Japan, Inc.

Shonan EMC Lab.

1-22-3 Megumigaoka, Hiratsuka-shi, Kanagawa-ken, 259-1220 JAPAN

Telephone : +81 463 50 6400

Facsimile : +81 463 50 6401

Radiated Spurious Emission
(Reference Plot for band-edge)

Report No. 12327685S-A
Test place Shonan EMC Lab.
Semi Anechoic Chamber No.2
Date May 27, 2018
Temperature / Humidity 24 deg.C / 56 %RH
Engineer Kenichi Adachi

Mode Tx, Hopping Off, DH5 2402 MHz

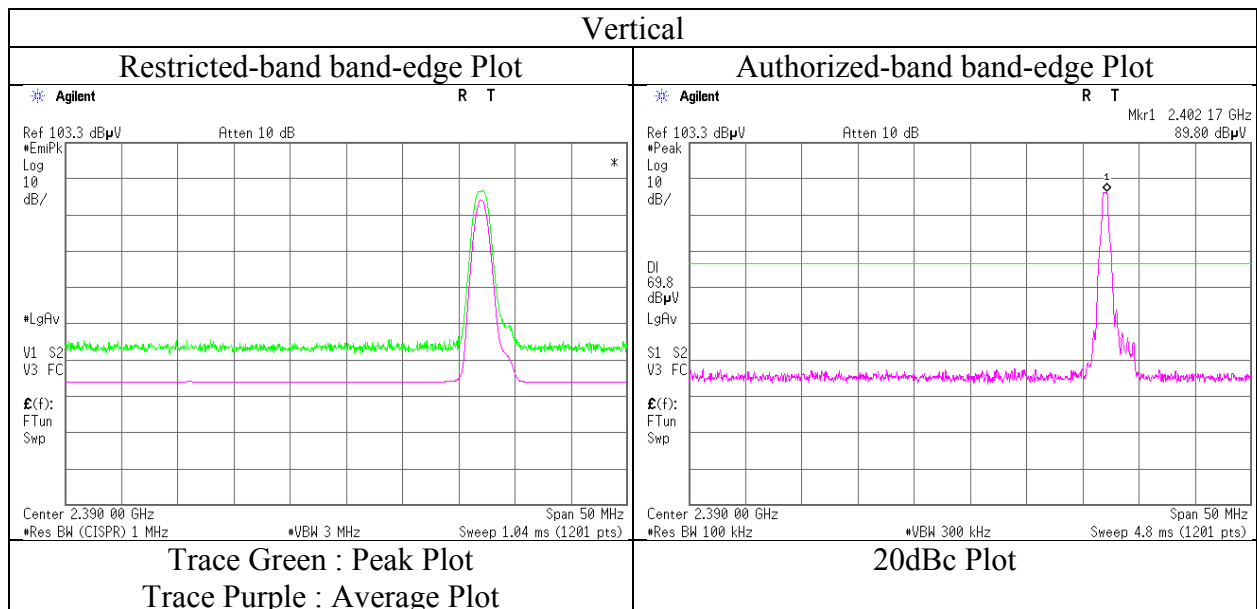
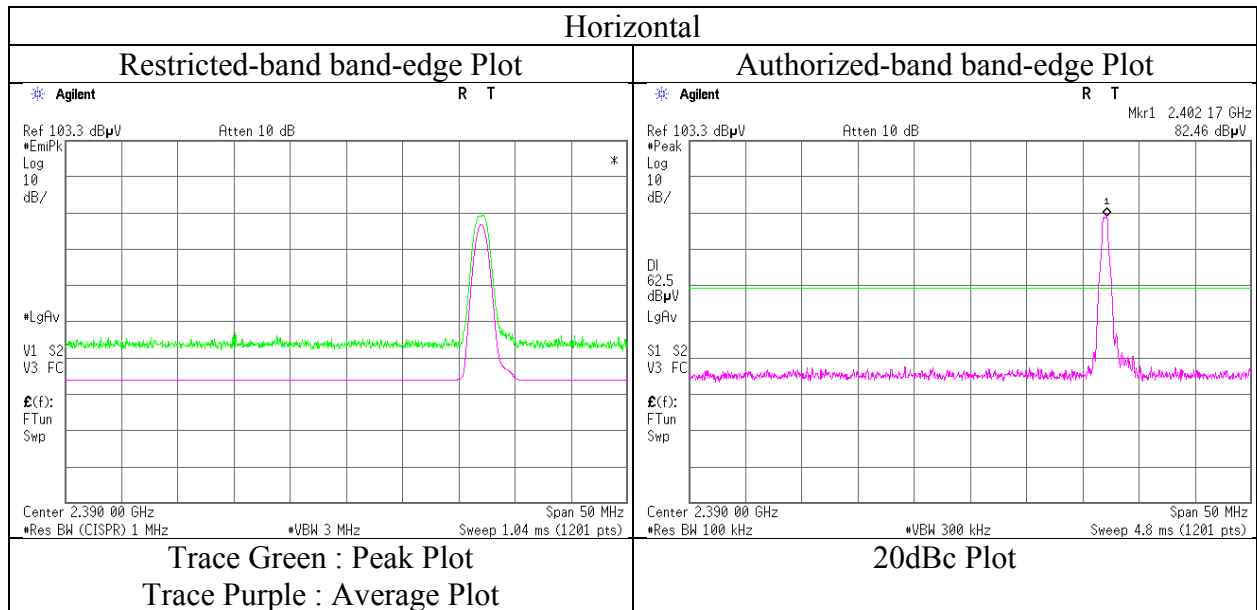

* Final result of restricted band edge was shown in tabular data.

Radiated Spurious Emission

Report No. 12327685S-A
Test place Shonan EMC Lab.
Semi Anechoic Chamber No.2
Date May 26, 2018 No.2
Temperature / Humidity 23 deg.C / 53 %RH 24 deg.C / 56 %RH
Engineer Yosuke Ishikawa Kenichi Adachi
(30 MHz -2.8 GHz) (2.8 GHz -26.5 GHz)
Mode Tx, Hopping Off, DH5 2441 MHz

(* PK: Peak, AV: Average, QP: Quasi-Peak)

Polarity	Frequency [MHz]	Detector	Reading [dBuV]	Ant.Fac. [dB/m]	Loss [dB]	Gain [dB]	Distance Factor [dB]	Result [dBuV/m]	Limit [dBuV/m]	Margin [dB]	Height [cm]	Angle [deg]	Remark
Hori.	72.210	QP	46.78	6.22	7.50	31.90	0.00	28.60	40.00	11.4	241	242	
Hori.	74.757	QP	51.56	6.21	7.54	31.90	0.00	33.41	40.00	6.6	264	232	
Hori.	83.988	QP	43.79	6.96	7.66	31.89	0.00	26.52	40.00	13.5	222	35	
Hori.	94.537	QP	44.43	8.98	7.81	31.88	0.00	29.34	43.50	14.2	205	232	
Hori.	140.943	QP	46.31	14.39	8.35	31.84	0.00	37.21	43.50	6.3	224	239	
Hori.	432.000	QP	52.77	16.14	7.18	31.67	0.00	44.42	46.00	1.6	222	311	
Hori.	864.000	QP	42.91	21.40	8.95	31.07	0.00	42.19	46.00	3.8	100	201	
Hori.	3118.303	PK	51.78	28.63	5.71	44.23	2.28	44.17	73.90	29.7	141	115	
Hori.	4882.000	PK	53.94	31.31	6.66	44.48	2.28	49.71	73.90	24.2	149	171	
Hori.	7323.000	PK	47.33	36.65	7.87	44.03	2.28	50.10	73.90	23.8	150	0	
Hori.	9764.000	PK	47.22	38.51	8.86	43.85	2.28	53.02	73.90	20.9	150	0	
Hori.	12205.000	PK	47.26	39.08	10.83	43.36	2.28	56.09	73.90	17.8	150	0	
Hori.	3118.303	AV	46.79	28.63	5.71	44.23	2.28	39.18	53.90	14.7	141	115	
Hori.	4882.000	AV	46.31	31.31	6.66	44.48	2.28	42.08	53.90	11.8	149	171	
Hori.	7323.000	AV	36.63	36.65	7.87	44.03	2.28	39.40	53.90	14.5	150	0	
Hori.	9764.000	AV	36.61	38.51	8.86	43.85	2.28	42.41	53.90	11.5	150	0	
Hori.	12205.000	AV	36.44	39.08	10.83	43.36	2.28	45.27	53.90	8.6	150	0	
Vert.	95.569	QP	47.48	9.19	7.82	31.88	0.00	32.61	43.50	10.9	100	268	
Vert.	140.946	QP	44.75	14.39	8.35	31.84	0.00	35.65	43.50	7.9	100	211	
Vert.	432.000	QP	50.71	16.14	7.18	31.67	0.00	42.36	46.00	3.6	100	157	
Vert.	3118.303	PK	50.85	28.63	5.71	44.23	2.28	43.24	73.90	30.7	152	136	
Vert.	4882.000	PK	53.38	31.31	6.66	44.48	2.28	49.15	73.90	24.8	154	194	
Vert.	7323.000	PK	47.29	36.65	7.87	44.03	2.28	50.06	73.90	23.8	150	0	
Vert.	9764.000	PK	47.26	38.51	8.86	43.85	2.28	53.06	73.90	20.8	150	0	
Vert.	12205.000	PK	47.21	39.08	10.83	43.36	2.28	56.04	73.90	17.9	150	0	
Vert.	3118.303	AV	39.97	28.63	5.71	44.23	2.28	32.36	53.90	21.5	152	136	
Vert.	4882.000	AV	45.73	31.31	6.66	44.48	2.28	41.50	53.90	12.4	154	194	
Vert.	7323.000	AV	36.59	36.65	7.87	44.03	2.28	39.36	53.90	14.5	150	0	
Vert.	9764.000	AV	36.65	38.51	8.86	43.85	2.28	42.45	53.90	11.5	150	0	
Vert.	12205.000	AV	36.36	39.08	10.83	43.36	2.28	45.19	53.90	8.7	150	0	

Result = Reading + Ant.Fac. + Loss (Cable+(Attenuator or Filter)(below 18 GHz)) - Gain(Amplifier) + Distance factor

Distance factor : 1 GHz - 13 GHz : $20\log(3.90\text{ m} / 3.0\text{ m}) = 2.28\text{ dB}$

13 GHz - 40 GHz : $20\log(1.0\text{ m} / 3.0\text{ m}) = -9.54\text{ dB}$

* These results have sufficient margin without taking account Dwell time factor.

UL Japan, Inc.

Shonan EMC Lab.

1-22-3 Megumigaoka, Hiratsuka-shi, Kanagawa-ken, 259-1220 JAPAN

Telephone : +81 463 50 6400

Facsimile : +81 463 50 6401

Radiated Spurious Emission

Report No. 12327685S-A
Test place Shonan EMC Lab.
Semi Anechoic Chamber No.2 No.2
Date May 26, 2018 May 27, 2018
Temperature / Humidity 23 deg.C / 53 %RH 24 deg.C / 56 %RH
Engineer Yosuke Ishikawa Kenichi Adachi
(30 MHz -2.8 GHz) (2.8 GHz -26.5 GHz)
Mode Tx, Hopping Off, DH5 2480 MHz

(* PK: Peak, AV: Average, QP: Quasi-Peak)

Polarity	Frequency [MHz]	Detector	Reading [dBuV]	Ant.Fac. [dB/m]	Loss [dB]	Gain [dB]	Distance Factor [dB]	Result [dBuV/m]	Limit [dBuV/m]	Margin [dB]	Height [cm]	Angle [deg]	Remark
Hori.	72.029	QP	46.01	6.22	7.50	31.90	0.00	27.83	40.00	12.2	232	228	
Hori.	74.725	QP	50.76	6.21	7.54	31.90	0.00	32.61	40.00	7.4	259	232	
Hori.	83.994	QP	43.67	6.96	7.66	31.89	0.00	26.40	40.00	13.6	198	34	
Hori.	94.507	QP	43.19	8.98	7.81	31.88	0.00	28.10	43.50	15.4	208	226	
Hori.	140.947	QP	46.33	14.39	8.35	31.84	0.00	37.23	43.50	6.3	225	240	
Hori.	432.000	QP	51.63	16.14	7.18	31.67	0.00	43.28	46.00	2.7	241	301	
Hori.	864.000	QP	42.67	21.40	8.95	31.07	0.00	41.95	46.00	4.1	100	204	
Hori.	2483.500	PK	49.27	27.48	13.37	44.16	2.28	48.24	73.90	25.7	140	141	
Hori.	3118.304	PK	52.48	28.63	5.71	44.23	2.28	44.87	73.90	29.0	136	122	
Hori.	4960.000	PK	52.21	31.48	6.70	44.51	2.28	48.16	73.90	25.7	152	164	
Hori.	7440.000	PK	48.17	36.81	7.99	44.08	2.28	51.17	73.90	22.7	150	0	
Hori.	9920.000	PK	47.64	38.82	9.04	43.87	2.28	53.91	73.90	20.0	150	0	
Hori.	12400.000	PK	47.48	39.10	11.22	43.36	2.28	56.72	73.90	17.2	150	0	
Hori.	2483.500	AV	36.88	27.48	13.37	44.16	2.28	35.85	53.90	18.1	140	141	
Hori.	3118.304	AV	43.02	28.63	5.71	44.23	2.28	35.41	53.90	18.5	136	122	
Hori.	4960.000	AV	44.86	31.48	6.70	44.51	2.28	40.81	53.90	13.1	152	164	
Hori.	7440.000	AV	37.21	36.81	7.99	44.08	2.28	40.21	53.90	13.7	150	0	
Hori.	9920.000	AV	36.68	38.82	9.04	43.87	2.28	42.95	53.90	11.0	150	0	
Hori.	12400.000	AV	36.33	39.10	11.22	43.36	2.28	45.57	53.90	8.3	150	0	
Vert.	95.562	QP	47.02	9.18	7.82	31.88	0.00	32.14	43.50	11.4	100	263	
Vert.	140.945	QP	44.78	14.39	8.35	31.84	0.00	35.68	43.50	7.8	100	218	
Vert.	432.000	QP	50.37	16.14	7.18	31.67	0.00	42.02	46.00	4.0	100	160	
Vert.	2483.500	PK	50.59	27.48	13.37	44.16	2.28	49.56	73.90	24.3	149	4	
Vert.	3118.304	PK	51.48	28.63	5.71	44.23	2.28	43.87	73.90	30.0	155	133	
Vert.	4960.000	PK	52.66	31.48	6.70	44.51	2.28	48.61	73.90	25.3	157	176	
Vert.	7440.000	PK	48.24	36.81	7.99	44.08	2.28	51.24	73.90	22.7	150	0	
Vert.	9920.000	PK	47.59	38.82	9.04	43.87	2.28	53.86	73.90	20.0	150	0	
Vert.	12400.000	PK	47.43	39.10	11.22	43.36	2.28	56.67	73.90	17.2	150	0	
Vert.	2483.500	AV	36.92	27.48	13.37	44.16	2.28	35.89	53.90	18.0	149	4	
Vert.	3118.304	AV	42.46	28.63	5.71	44.23	2.28	34.85	53.90	19.1	155	133	
Vert.	4960.000	AV	44.57	31.48	6.70	44.51	2.28	40.52	53.90	13.4	157	176	
Vert.	7440.000	AV	37.25	36.81	7.99	44.08	2.28	40.25	53.90	13.7	150	0	
Vert.	9920.000	AV	36.64	38.82	9.04	43.87	2.28	42.91	53.90	11.0	150	0	
Vert.	12400.000	AV	36.26	39.10	11.22	43.36	2.28	45.50	53.90	8.4	150	0	

Result = Reading + Ant.Fac. + Loss (Cable+(Attenuator or Filter)(below 18 GHz)) - Gain(Amplifier) + Distance factor

Distance factor : 1 GHz - 13 GHz : 20log(3.90 m / 3.0 m) = 2.28 dB

13 GHz - 40 GHz : 20log(1.0 m / 3.0 m) = -9.54 dB

* These results have sufficient margin without taking account Dwell time factor.

Radiated Spurious Emission
(Reference Plot for band-edge)

Report No.	12327685S-A
Test place	Shonan EMC Lab.
Semi Anechoic Chamber	No.2
Date	May 27, 2018
Temperature / Humidity	24 deg.C / 56 %RH
Engineer	Kenichi Adachi
Mode	Tx, Hopping Off, DH5 2480 MHz

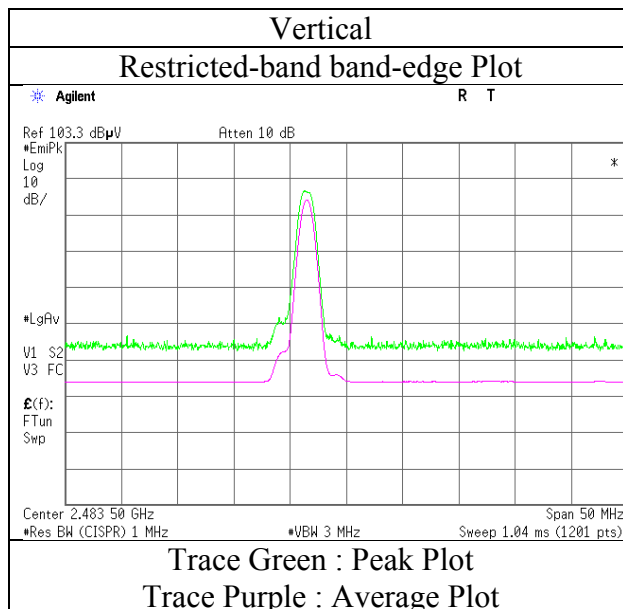
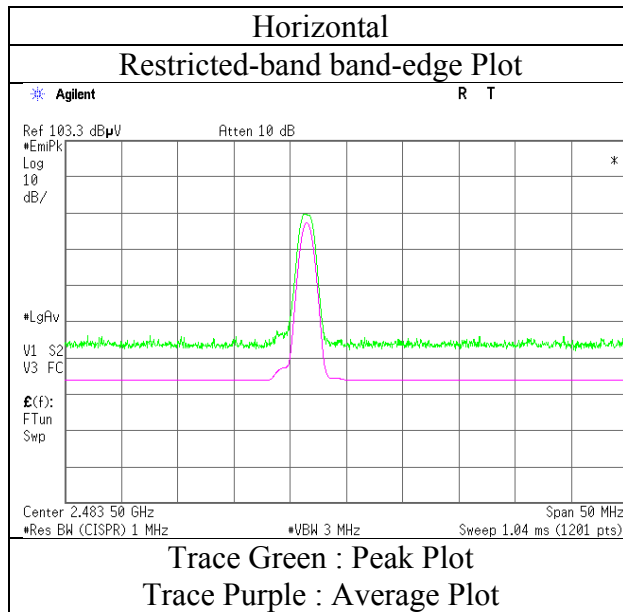

* Final result of restricted band edge was shown in tabular data.

Radiated Spurious Emission

Report No.	12327685S-A	
Test place	Shonan EMC Lab.	
Semi Anechoic Chamber	No.2	No.2
Date	May 26, 2018	May 27, 2018
Temperature / Humidity	23 deg.C / 53 %RH	24 deg.C / 56 %RH
Engineer	Yosuke Ishikawa	Kenichi Adachi
	(30 MHz -2.8 GHz)	(2.8 GHz -26.5 GHz)
Mode	Tx, Hopping Off, 3DH5 2402 MHz	

(* PK: Peak, AV: Average, QP: Quasi-Peak)

Polarity	Frequency [MHz]	Detector	Reading [dBuV]	Ant.Fac. [dB/m]	Loss [dB]	Gain [dB]	Distance Factor [dB]	Result [dBuV/m]	Limit [dBuV/m]	Margin [dB]	Height [cm]	Angle [deg]	Remark
Hori.	72.212	QP	45.81	6.22	7.50	31.90	0.00	27.63	40.00	12.4	237	228	
Hori.	74.758	QP	51.55	6.21	7.54	31.90	0.00	33.40	40.00	6.6	233	224	
Hori.	83.078	QP	52.38	6.78	7.65	31.89	0.00	34.92	40.00	5.1	220	30	
Hori.	94.533	QP	45.72	8.98	7.81	31.88	0.00	30.63	43.50	12.9	209	223	
Hori.	141.003	QP	46.35	14.39	8.35	31.84	0.00	37.25	43.50	6.3	223	233	
Hori.	432.000	QP	51.44	16.14	7.18	31.67	0.00	43.09	46.00	2.9	202	199	
Hori.	864.000	QP	42.62	21.40	8.95	31.07	0.00	41.90	46.00	4.1	100	211	
Hori.	2390.000	PK	49.33	27.16	13.31	44.13	2.28	47.95	73.90	26.0	147	146	
Hori.	3118.305	PK	52.46	28.63	5.71	44.23	2.28	44.85	73.90	29.1	138	118	
Hori.	4804.000	PK	53.14	31.14	6.62	44.45	2.28	48.73	73.90	25.2	153	166	
Hori.	7206.000	PK	47.65	36.48	7.76	43.99	2.28	50.18	73.90	23.7	150	0	
Hori.	9608.000	PK	48.39	38.20	8.69	43.83	2.28	53.73	73.90	20.2	150	0	
Hori.	12010.000	PK	48.52	39.06	10.45	43.36	2.28	56.95	73.90	17.0	150	0	
Hori.	2390.000	AV	36.65	27.16	13.31	44.13	2.28	35.27	53.90	18.6	147	146	
Hori.	3118.305	AV	43.01	28.63	5.71	44.23	2.28	35.40	53.90	18.5	138	118	
Hori.	4804.000	AV	42.89	31.14	6.62	44.45	2.28	38.48	53.90	15.4	153	166	
Hori.	7206.000	AV	36.09	36.48	7.76	43.99	2.28	38.62	53.90	15.3	150	0	
Hori.	9608.000	AV	37.26	38.20	8.69	43.83	2.28	42.60	53.90	11.3	150	0	
Hori.	12010.000	AV	36.47	39.06	10.45	43.36	2.28	44.90	53.90	9.0	150	0	
Vert.	95.576	QP	47.27	9.19	7.82	31.88	0.00	32.40	43.50	11.1	100	262	
Vert.	141.001	QP	44.87	14.39	8.35	31.84	0.00	35.77	43.50	7.7	100	214	
Vert.	432.000	QP	50.40	16.14	7.18	31.67	0.00	42.05	46.00	4.0	100	164	
Vert.	2390.000	PK	49.21	27.16	13.31	44.13	2.28	47.83	73.90	26.1	148	349	
Vert.	3118.305	PK	51.77	28.63	5.71	44.23	2.28	44.16	73.90	29.7	148	134	
Vert.	4804.000	PK	52.66	31.14	6.62	44.45	2.28	48.25	73.90	25.7	152	197	
Vert.	7206.000	PK	47.74	36.48	7.76	43.99	2.28	50.27	73.90	23.6	150	0	
Vert.	9608.000	PK	48.21	38.20	8.69	43.83	2.28	53.55	73.90	20.4	150	0	
Vert.	12010.000	PK	48.44	39.06	10.45	43.36	2.28	56.87	73.90	17.0	150	0	
Vert.	2390.000	AV	36.82	27.16	13.31	44.13	2.28	35.44	53.90	18.5	148	349	
Vert.	3118.305	AV	42.78	28.63	5.71	44.23	2.28	35.17	53.90	18.7	148	134	
Vert.	4804.000	AV	42.42	31.14	6.62	44.45	2.28	38.01	53.90	15.9	152	197	
Vert.	7206.000	AV	36.15	36.48	7.76	43.99	2.28	38.68	53.90	15.2	150	0	
Vert.	9608.000	AV	37.16	38.20	8.69	43.83	2.28	42.50	53.90	11.4	150	0	
Vert.	12010.000	AV	36.45	39.06	10.45	43.36	2.28	44.88	53.90	9.0	150	0	

Result = Reading + Ant.Fac. + Loss (Cable+(Attenuator or Filter)(below 18 GHz)) - Gain(Amplifier) + Distance factor

Distance factor : 1 GHz - 13 GHz : 20log(3.90 m / 3.0 m) = 2.28 dB

13 GHz - 40 GHz : 20log(1.0 m / 3.0 m) = -9.54 dB

* These results have sufficient margin without taking account Dwell time factor.

20 dBc Data Sheet (RBW 100 kHz, VBW 300 kHz)

Polarity	Frequency [MHz]	Detector	Reading [dBuV]	Ant.Fac. [dB/m]	Loss [dB]	Gain [dB]	Distance Factor [dB]	Result [dBuV/m]	Limit [dBuV/m]	Margin [dB]	Remark
Hori.	2402.000	PK	84.11	27.20	13.92	44.14	2.28	83.37	-	-	Carrier
Hori.	2400.000	PK	40.56	27.20	13.32	44.14	2.28	39.22	63.37	24.2	
Vert.	2402.000	PK	90.32	27.20	13.92	44.14	2.28	89.58	-	-	Carrier
Vert.	2400.000	PK	42.77	27.20	13.32	44.14	2.28	41.43	69.58	28.2	

Result = Reading + Ant.Fac. + Loss (Cable+(Attenuator or Filter)(below 18 GHz)) - Gain(Amplifier) + Distance factor

Distance factor : 1 GHz - 13 GHz : 20log(3.90 m / 3.0 m) = 2.28 dB

13 GHz - 40 GHz : 20log(1.0 m / 3.0 m) = -9.54 dB

UL Japan, Inc.

Shonan EMC Lab.

1-22-3 Megumigaoka, Hiratsuka-shi, Kanagawa-ken, 259-1220 JAPAN

Telephone : +81 463 50 6400

Facsimile : +81 463 50 6401

Radiated Spurious Emission (Reference Plot for band-edge)

Report No.	12327685S-A
Test place	Shonan EMC Lab.
Semi Anechoic Chamber	No.2
Date	May 27, 2018
Temperature / Humidity	24 deg.C / 56 %RH
Engineer	Kenichi Adachi
Mode	Tx, Hopping Off, 3DH5 2402 MHz

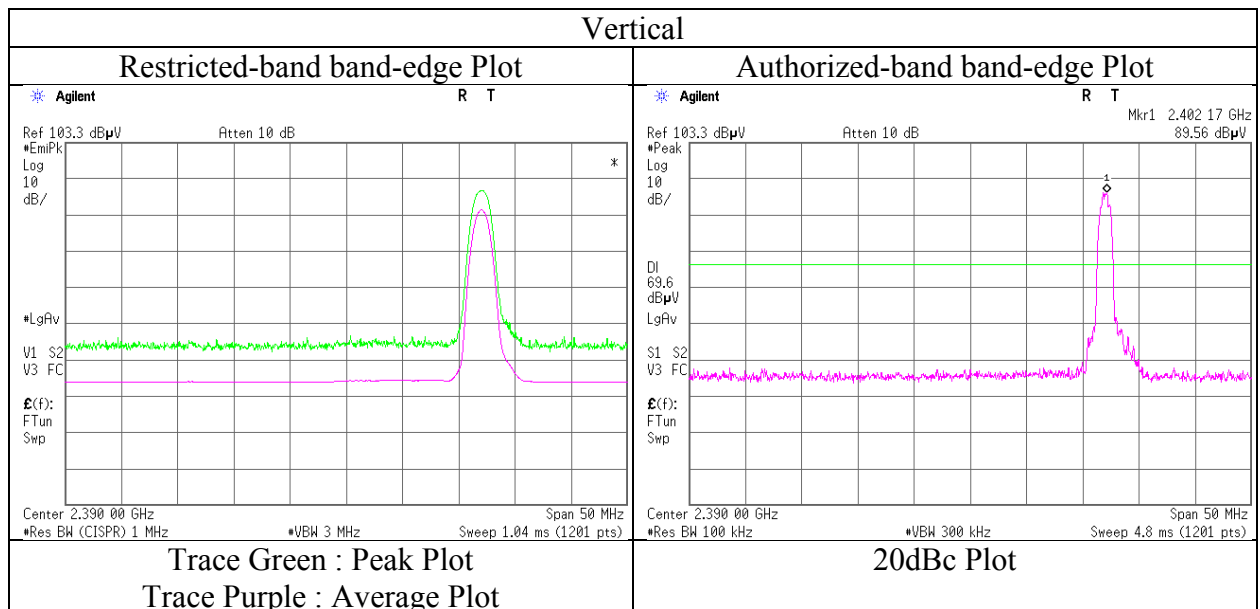
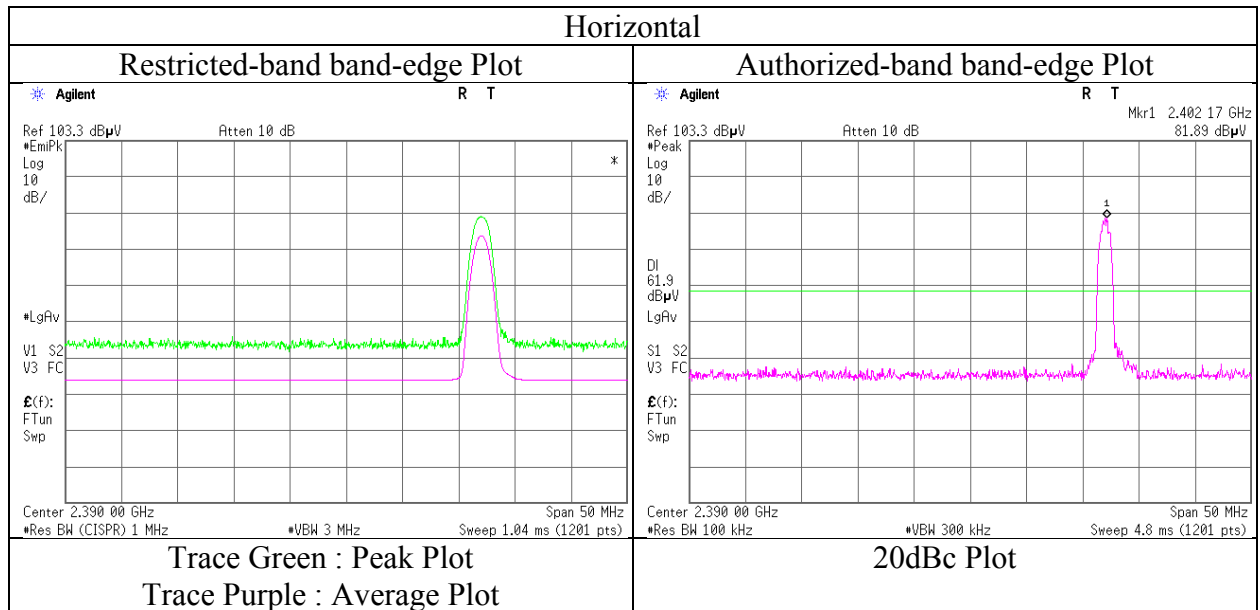

* Final result of restricted band edge was shown in tabular data.

Radiated Spurious Emission

Report No.	12327685S-A	
Test place	Shonan EMC Lab.	
Semi Anechoic Chamber	No.2	No.2
Date	May 26, 2018	May 27, 2018
Temperature / Humidity	23 deg.C / 53 %RH	24 deg.C / 56 %RH
Engineer	Yosuke Ishikawa	Kenichi Adachi
	(30 MHz -2.8 GHz)	(2.8 GHz -26.5 GHz)
Mode	Tx, Hopping Off, 3DH5 2441 MHz	

(* PK: Peak, AV: Average, QP: Quasi-Peak)

Polarity	Frequency [MHz]	Detector	Reading [dBuV]	Ant.Fac. [dB/m]	Loss [dB]	Gain [dB]	Distance Factor [dB]	Result [dBuV/m]	Limit [dBuV/m]	Margin [dB]	Height [cm]	Angle [deg]	Remark
Hori.	72.218	QP	47.26	6.22	7.50	31.90	0.00	29.08	40.00	10.9	236	229	
Hori.	74.758	QP	50.68	6.21	7.54	31.90	0.00	32.53	40.00	7.5	226	210	
Hori.	83.046	QP	51.04	6.78	7.65	31.89	0.00	33.58	40.00	6.4	246	45	
Hori.	94.546	QP	44.38	8.99	7.81	31.88	0.00	29.30	43.50	14.2	208	226	
Hori.	140.978	QP	46.17	14.39	8.35	31.84	0.00	37.07	43.50	6.4	229	228	
Hori.	432.000	QP	52.56	16.14	7.18	31.67	0.00	44.21	46.00	1.8	198	198	
Hori.	864.000	QP	42.46	21.40	8.95	31.07	0.00	41.74	46.00	4.3	100	219	
Hori.	3118.306	PK	51.44	28.63	5.71	44.23	2.28	43.83	73.90	30.1	139	114	
Hori.	4882.000	PK	53.48	31.31	6.66	44.48	2.28	49.25	73.90	24.7	151	179	
Hori.	7323.000	PK	47.35	36.65	7.87	44.03	2.28	50.12	73.90	23.8	150	0	
Hori.	9764.000	PK	47.30	38.51	8.86	43.85	2.28	53.10	73.90	20.8	150	0	
Hori.	12205.000	PK	47.21	39.08	10.83	43.36	2.28	56.04	73.90	17.9	150	0	
Hori.	3118.306	AV	46.56	28.63	5.71	44.23	2.28	38.95	53.90	15.0	139	114	
Hori.	4882.000	AV	45.68	31.31	6.66	44.48	2.28	41.45	53.90	12.5	151	179	
Hori.	7323.000	AV	36.65	36.65	7.87	44.03	2.28	39.42	53.90	14.5	150	0	
Hori.	9764.000	AV	36.66	38.51	8.86	43.85	2.28	42.46	53.90	11.4	150	0	
Hori.	12205.000	AV	36.33	39.08	10.83	43.36	2.28	45.16	53.90	8.7	150	0	
Vert.	95.581	QP	47.27	9.19	7.82	31.88	0.00	32.40	43.50	11.1	100	273	
Vert.	140.985	QP	44.68	14.39	8.35	31.84	0.00	35.58	43.50	7.9	100	222	
Vert.	432.000	QP	50.62	16.14	7.18	31.67	0.00	42.27	46.00	3.7	100	161	
Vert.	3118.306	PK	50.66	28.63	5.71	44.23	2.28	43.05	73.90	30.9	153	133	
Vert.	4882.000	PK	52.94	31.31	6.66	44.48	2.28	48.71	73.90	25.2	151	192	
Vert.	7323.000	PK	47.27	36.65	7.87	44.03	2.28	50.04	73.90	23.9	150	0	
Vert.	9764.000	PK	47.21	38.51	8.86	43.85	2.28	53.01	73.90	20.9	150	0	
Vert.	12205.000	PK	47.29	39.08	10.83	43.36	2.28	56.12	73.90	17.8	150	0	
Vert.	3118.306	AV	39.78	28.63	5.71	44.23	2.28	32.17	53.90	21.7	153	133	
Vert.	4882.000	AV	45.11	31.31	6.66	44.48	2.28	40.88	53.90	13.0	151	192	
Vert.	7323.000	AV	36.58	36.65	7.87	44.03	2.28	39.35	53.90	14.6	150	0	
Vert.	9764.000	AV	36.60	38.51	8.86	43.85	2.28	42.40	53.90	11.5	150	0	
Vert.	12205.000	AV	36.45	39.08	10.83	43.36	2.28	45.28	53.90	8.6	150	0	

Result = Reading + Ant.Fac. + Loss (Cable+(Attenuator or Filter)(below 18 GHz)) - Gain(Amplifier) + Distance factor

Distance factor : 1 GHz - 13 GHz : $20\log(3.90\text{ m} / 3.0\text{ m}) = 2.28\text{ dB}$

13 GHz - 40 GHz : $20\log(1.0\text{ m} / 3.0\text{ m}) = -9.54\text{ dB}$

* These results have sufficient margin without taking account Dwell time factor.

Radiated Spurious Emission

Report No.	12327685S-A	
Test place	Shonan EMC Lab.	
Semi Anechoic Chamber	No.2	No.2
Date	May 26, 2018	May 27, 2018
Temperature / Humidity	23 deg.C / 53 %RH	24 deg.C / 56 %RH
Engineer	Yosuke Ishikawa	Kenichi Adachi
	(30 MHz -2.8 GHz)	(2.8 GHz -26.5 GHz)
Mode	Tx, Hopping Off, 3DH5 2480 MHz	

(* PK: Peak, AV: Average, QP: Quasi-Peak)

Polarity	Frequency [MHz]	Detector	Reading [dBuV]	Ant.Fac. [dB/m]	Loss [dB]	Gain [dB]	Distance Factor [dB]	Result [dBuV/m]	Limit [dBuV/m]	Margin [dB]	Height [cm]	Angle [deg]	Remark
Hori.	72.212	QP	48.66	6.22	7.50	31.90	0.00	30.48	40.00	9.5	223	227	
Hori.	74.767	QP	51.89	6.21	7.54	31.90	0.00	33.74	40.00	6.3	244	228	
Hori.	83.077	QP	52.76	6.78	7.65	31.89	0.00	35.30	40.00	4.7	211	43	
Hori.	94.539	QP	45.78	8.99	7.81	31.88	0.00	30.70	43.50	12.8	208	226	
Hori.	141.003	QP	45.97	14.39	8.35	31.84	0.00	36.87	43.50	6.6	203	223	
Hori.	432.000	QP	52.62	16.14	7.18	31.67	0.00	44.27	46.00	1.7	199	302	
Hori.	864.000	QP	42.08	21.40	8.95	31.07	0.00	41.36	46.00	4.6	100	219	
Hori.	2483.500	PK	50.05	27.48	13.37	44.16	2.28	49.02	73.90	24.9	136	137	
Hori.	3118.302	PK	51.24	28.63	5.71	44.23	2.28	43.63	73.90	30.3	139	123	
Hori.	4960.000	PK	51.97	31.48	6.70	44.51	2.28	47.92	73.90	26.0	154	165	
Hori.	7440.000	PK	48.24	36.81	7.99	44.08	2.28	51.24	73.90	22.7	150	0	
Hori.	9920.000	PK	47.66	38.82	9.04	43.87	2.28	53.93	73.90	20.0	150	0	
Hori.	12400.000	PK	47.41	39.10	11.22	43.36	2.28	56.65	73.90	17.3	150	0	
Hori.	2483.500	AV	36.91	27.48	13.37	44.16	2.28	35.88	53.90	18.0	136	137	
Hori.	3118.302	AV	41.81	28.63	5.71	44.23	2.28	34.20	53.90	19.7	139	123	
Hori.	4960.000	AV	43.56	31.48	6.70	44.51	2.28	39.51	53.90	14.4	154	165	
Hori.	7440.000	AV	37.27	36.81	7.99	44.08	2.28	40.27	53.90	13.6	150	0	
Hori.	9920.000	AV	36.71	38.82	9.04	43.87	2.28	42.98	53.90	10.9	150	0	
Hori.	12400.000	AV	36.23	39.10	11.22	43.36	2.28	45.47	53.90	8.4	150	0	
Vert.	95.583	QP	47.68	9.19	7.82	31.88	0.00	32.81	43.50	10.7	100	267	
Vert.	141.003	QP	44.72	14.39	8.35	31.84	0.00	35.62	43.50	7.9	100	209	
Vert.	432.000	QP	50.87	16.14	7.18	31.67	0.00	42.52	46.00	3.5	100	159	
Vert.	2483.500	PK	49.89	27.48	13.37	44.16	2.28	48.86	73.90	25.0	147	3	
Vert.	3118.302	PK	50.14	28.63	5.71	44.23	2.28	42.53	73.90	31.4	154	136	
Vert.	4960.000	PK	51.35	31.48	6.70	44.51	2.28	47.30	73.90	26.6	152	177	
Vert.	7440.000	PK	48.13	36.81	7.99	44.08	2.28	51.13	73.90	22.8	150	0	
Vert.	9920.000	PK	47.64	38.82	9.04	43.87	2.28	53.91	73.90	20.0	150	0	
Vert.	12400.000	PK	47.51	39.10	11.22	43.36	2.28	56.75	73.90	17.2	150	0	
Vert.	2483.500	AV	36.89	27.48	13.37	44.16	2.28	35.86	53.90	18.0	147	3	
Vert.	3118.302	AV	41.28	28.63	5.71	44.23	2.28	33.67	53.90	20.2	154	136	
Vert.	4960.000	AV	43.22	31.48	6.70	44.51	2.28	39.17	53.90	14.7	152	177	
Vert.	7440.000	AV	37.22	36.81	7.99	44.08	2.28	40.22	53.90	13.7	150	0	
Vert.	9920.000	AV	36.61	38.82	9.04	43.87	2.28	42.88	53.90	11.0	150	0	
Vert.	12400.000	AV	36.35	39.10	11.22	43.36	2.28	45.59	53.90	8.3	150	0	

Result = Reading + Ant.Fac. + Loss (Cable+(Attenuator or Filter)(below 18 GHz)) - Gain(Amplifier) + Distance factor

Distance factor : 1 GHz - 13 GHz : 20log(3.90 m / 3.0 m) = 2.28 dB

13 GHz - 40 GHz : 20log(1.0 m / 3.0 m) = -9.54 dB

* These results have sufficient margin without taking account Dwell time factor.

Radiated Spurious Emission
(Reference Plot for band-edge)

Report No. 12327685S-A
Test place Shonan EMC Lab.
Semi Anechoic Chamber No.2
Date May 27, 2018
Temperature / Humidity 24 deg.C / 56 %RH
Engineer Kenichi Adachi
Mode Tx, Hopping Off, 3DH5 2480 MHz

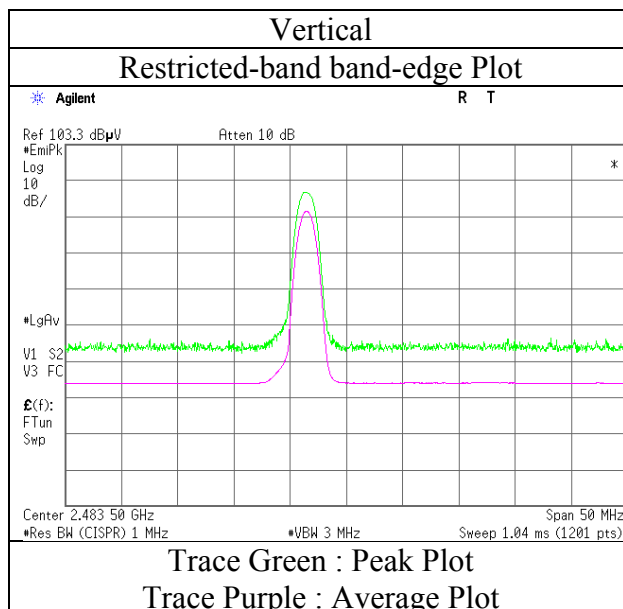
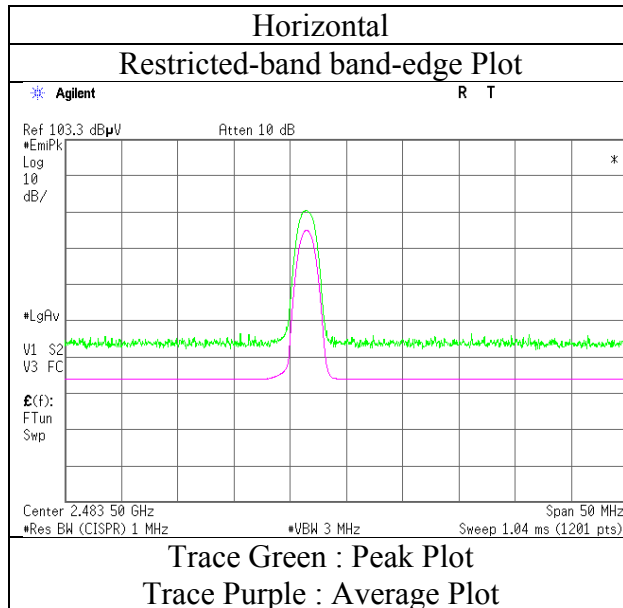

* Final result of restricted band edge was shown in tabular data.

Radiated Spurious Emission (Plot data, Worst case)

Report No.	12327685S-A	
Test place	Shonan EMC Lab.	
Semi Anechoic Chamber	No.2	No.2
Date	May 26, 2018	May 27, 2018
Temperature / Humidity	23 deg.C / 53 %RH	24 deg.C / 56 %RH
Engineer	Yosuke Ishikawa	Kenichi Adachi
	(30 MHz -2.8 GHz)	(2.8 GHz -26.5 GHz)
Mode	Tx, Hopping Off, 3DH5 2441 MHz	

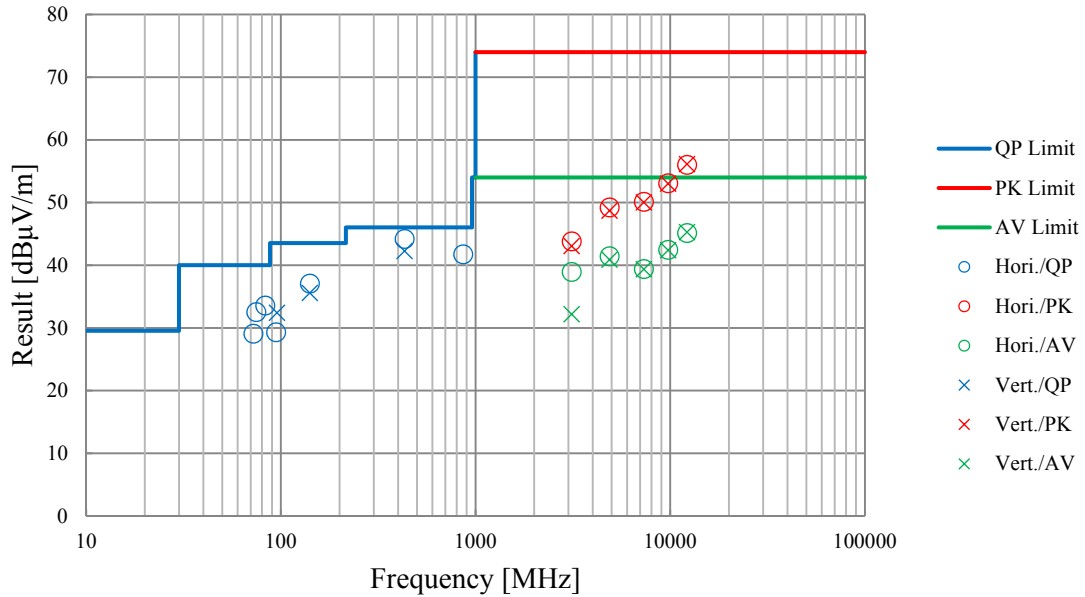

*These plots data contains sufficient number to show the trend of characteristic features for EUT.

Conducted Spurious Emission

Report No.	12327685S-A
Test place	Shonan EMC Lab. No.6 Shielded Room
Date	May 24, 2018
Temperature / Humidity	26 deg. C / 54 % RH
Engineer	Yosuke Ishikawa
Mode	Tx, Hopping Off, DH5

2402 MHz

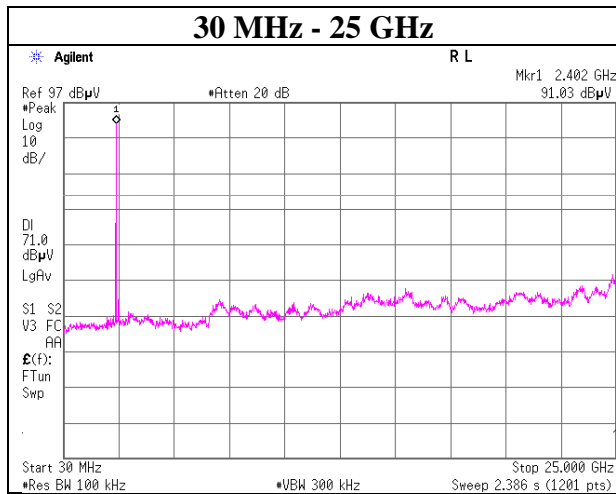
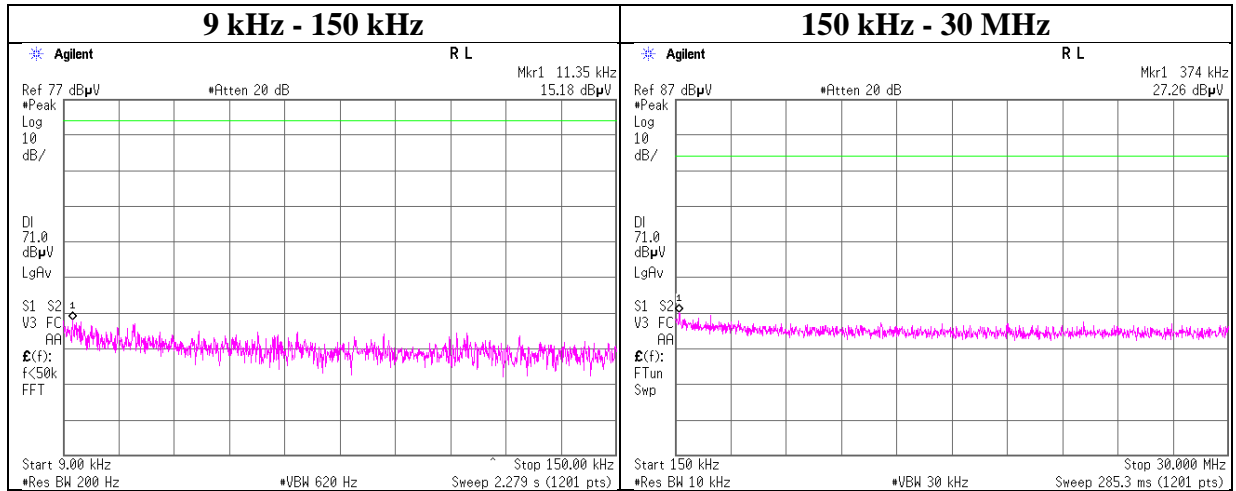

Conducted Spurious Emission

Report No.	12327685S-A
Test place	Shonan EMC Lab. No.6 Shielded Room
Date	May 24, 2018
Temperature / Humidity	26 deg. C / 54 % RH
Engineer	Yosuke Ishikawa
Mode	Tx, Hopping Off, DH5

2441 MHz

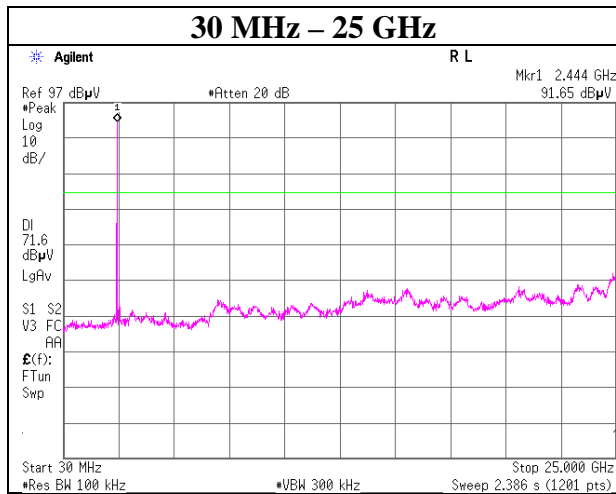
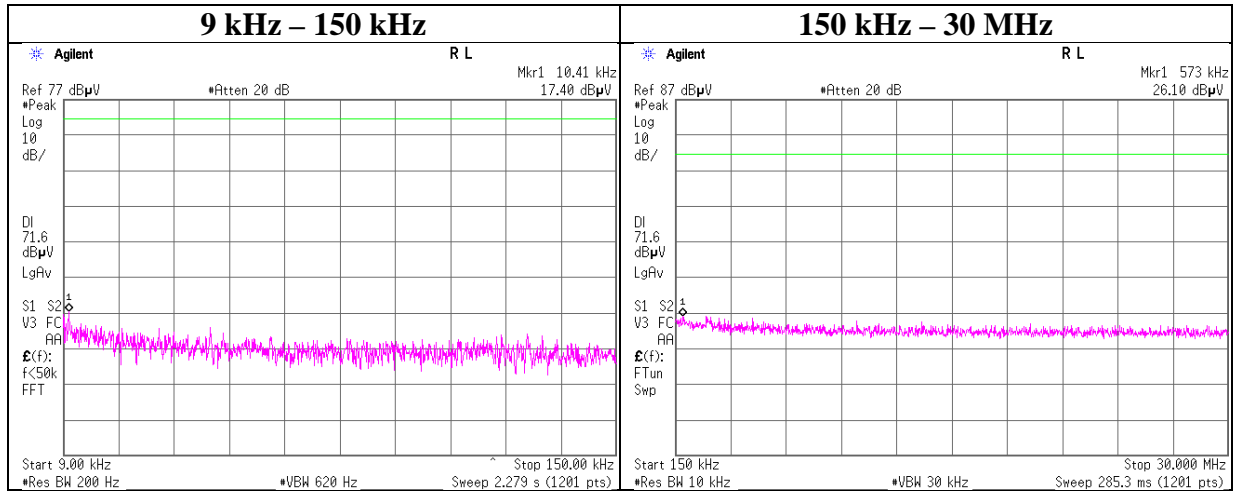

Conducted Spurious Emission

Report No.	12327685S-A
Test place	Shonan EMC Lab. No.6 Shielded Room
Date	May 24, 2018
Temperature / Humidity	26 deg. C / 54 % RH
Engineer	Yosuke Ishikawa
Mode	Tx, Hopping Off, DH5

2480 MHz

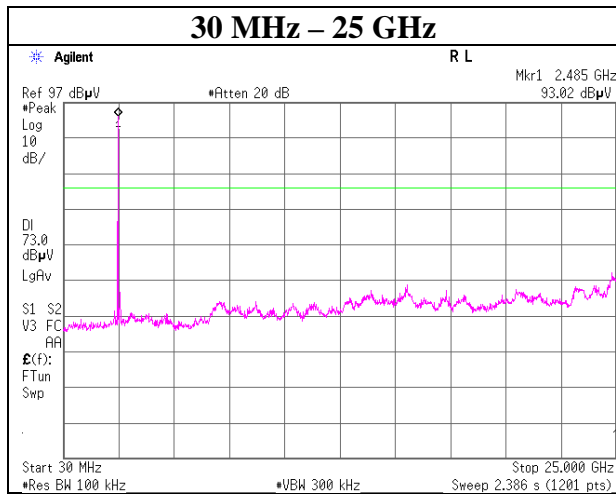
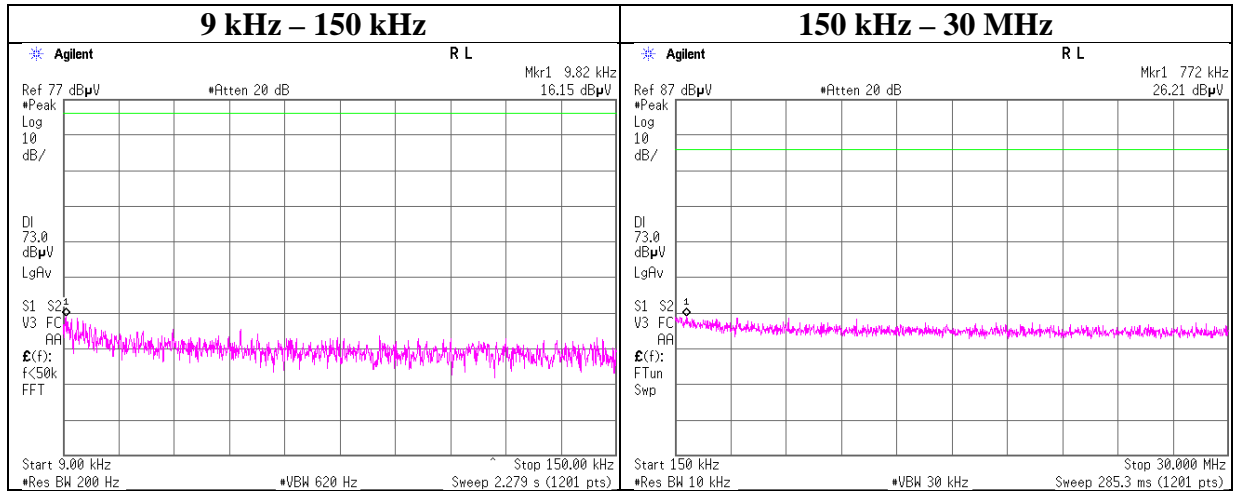

Conducted Spurious Emission

Report No.	12327685S-A
Test place	Shonan EMC Lab. No.6 Shielded Room
Date	May 24, 2018
Temperature / Humidity	26 deg. C / 54 % RH
Engineer	Yosuke Ishikawa
Mode	Tx, Hopping Off, 3DH5

2402 MHz

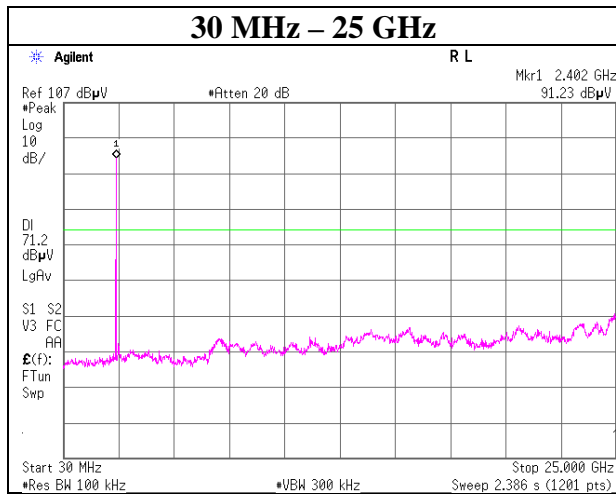
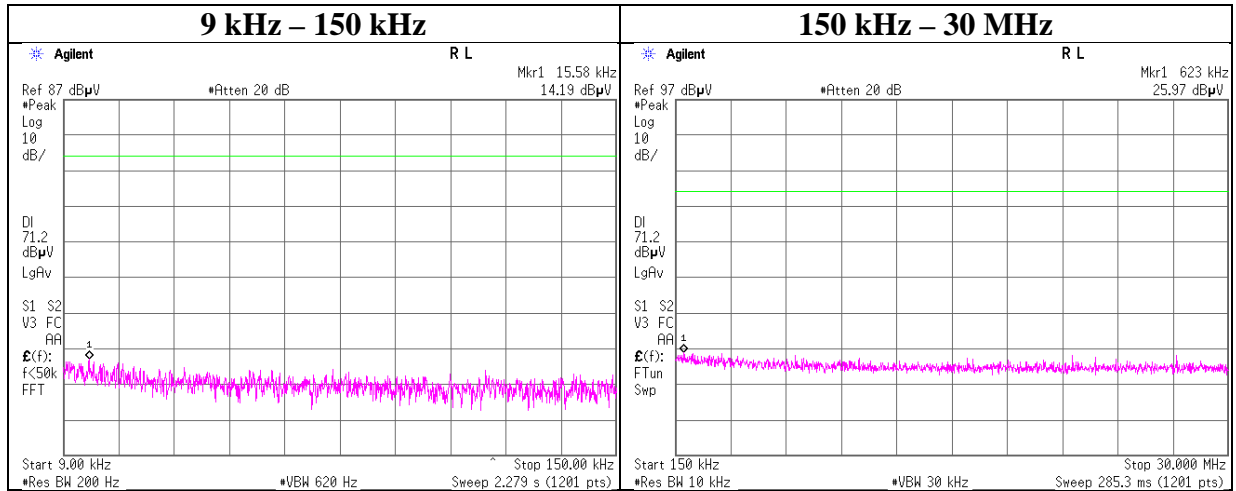

UL Japan, Inc.

Shonan EMC Lab.

1-22-3 Megumigaoka, Hiratsuka-shi, Kanagawa-ken, 259-1220 JAPAN

Telephone : +81 463 50 6400

Facsimile : +81 463 50 6401

Conducted Spurious Emission

Report No.	12327685S-A
Test place	Shonan EMC Lab. No.6 Shielded Room
Date	May 24, 2018
Temperature / Humidity	26 deg. C / 54 % RH
Engineer	Yosuke Ishikawa
Mode	Tx, Hopping Off, 3DH5

2441 MHz

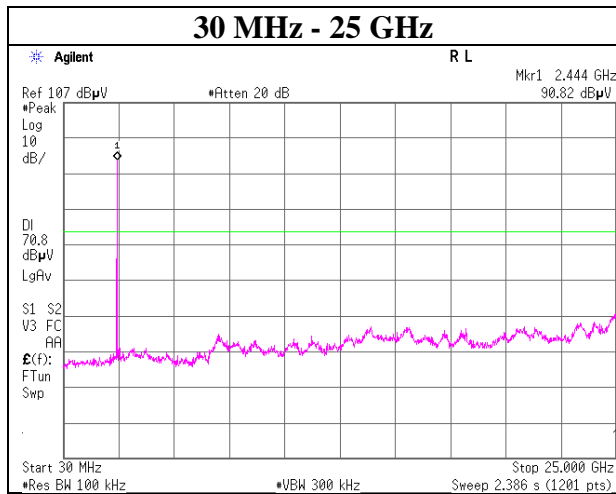
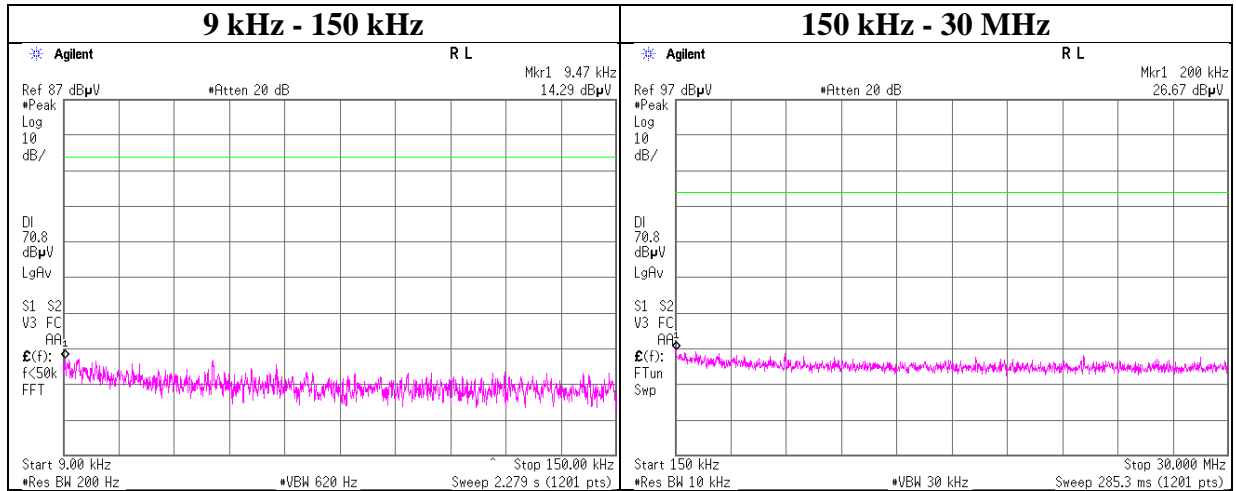

UL Japan, Inc.

Shonan EMC Lab.

1-22-3 Megumigaoka, Hiratsuka-shi, Kanagawa-ken, 259-1220 JAPAN

Telephone : +81 463 50 6400

Facsimile : +81 463 50 6401

Conducted Spurious Emission

Report No.	12327685S-A
Test place	Shonan EMC Lab. No.6 Shielded Room
Date	May 24, 2018
Temperature / Humidity	26 deg. C / 54 % RH
Engineer	Yosuke Ishikawa
Mode	Tx, Hopping Off, 3DH5

2480 MHz

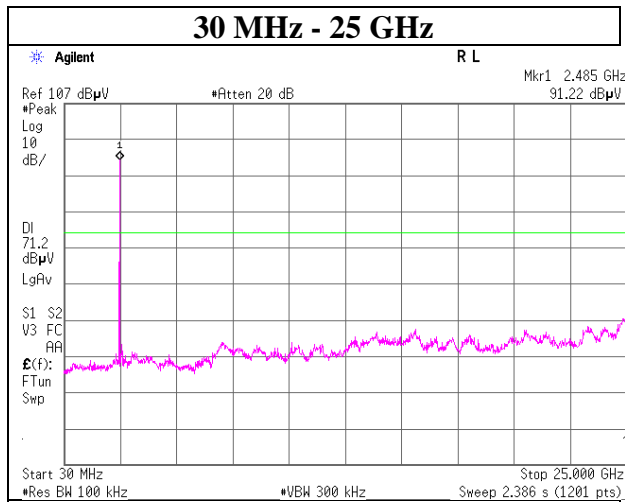
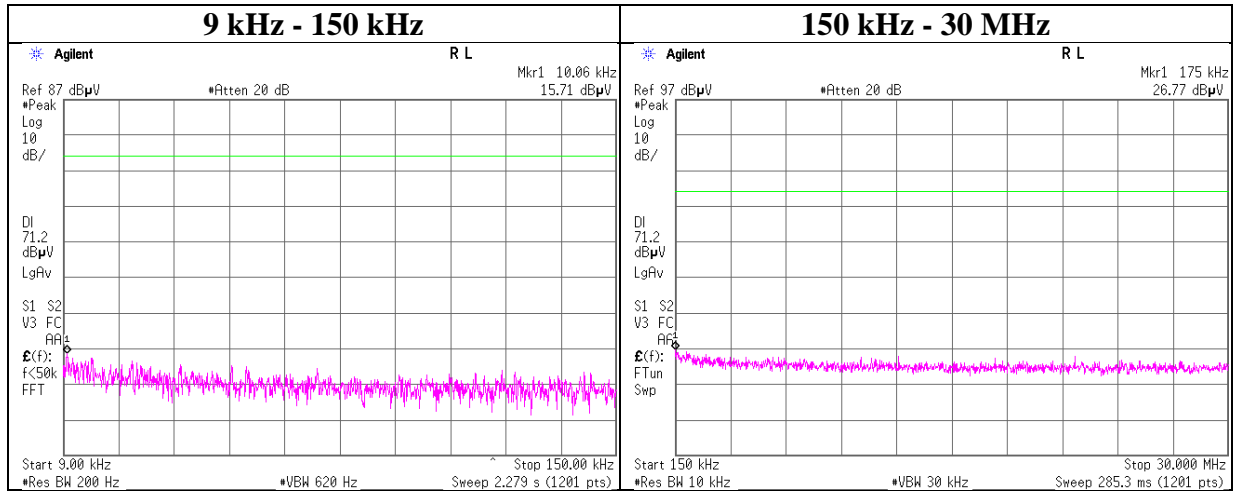

Conducted Emission Band Edge compliance

Report No. 12327685S-A
 Test place Shonan EMC Lab. No.6 Shielded Room
 Date May 24, 2018
 Temperature / Humidity 26 deg. C / 54 % RH
 Engineer Yosuke Ishikawa
 Mode Tx DH5

Hopping On

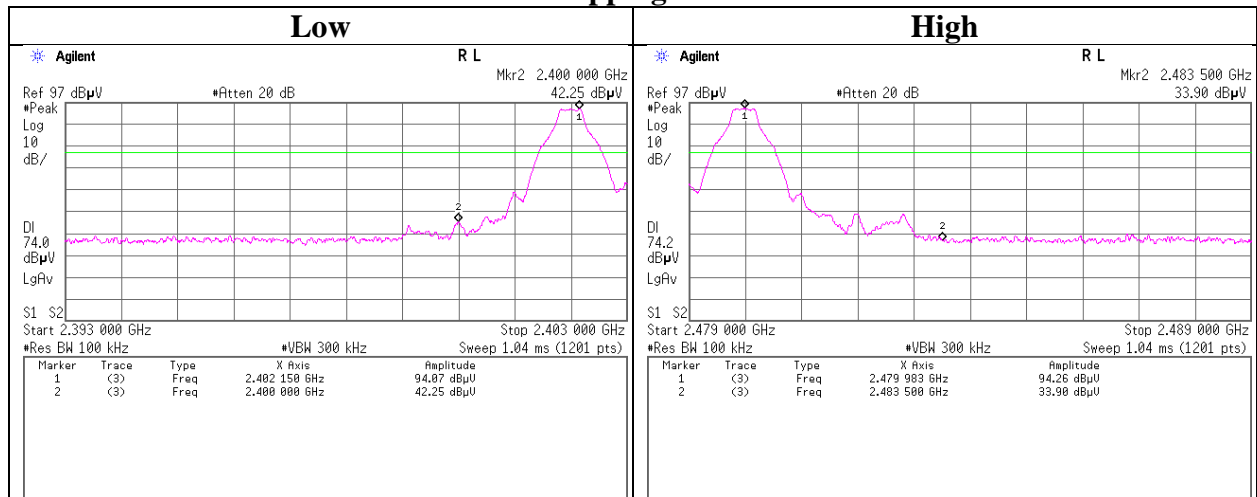

Hopping Off

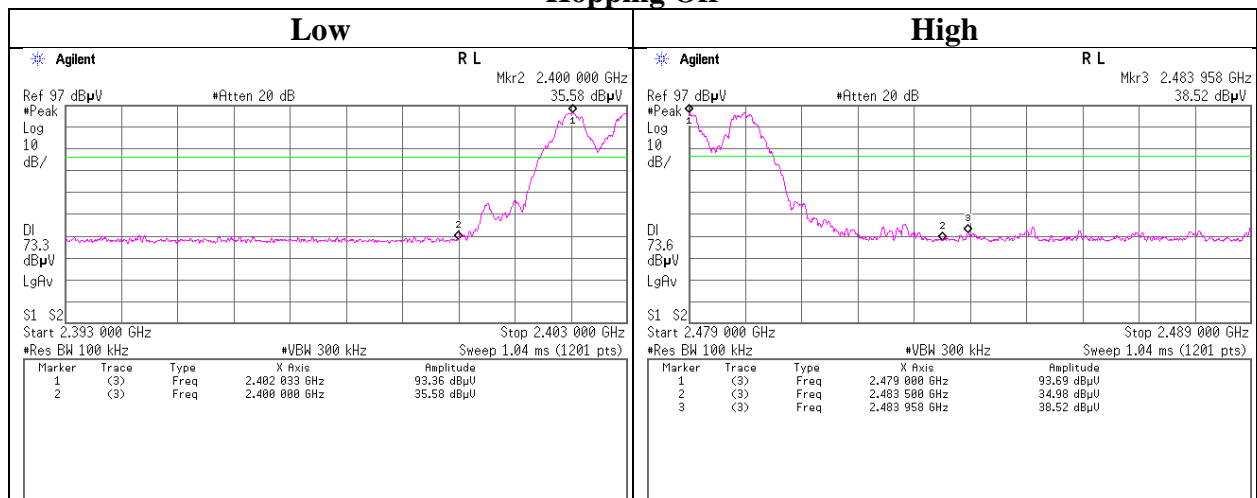

UL Japan, Inc.

Shonan EMC Lab.

1-22-3 Megumigaoka, Hiratsuka-shi, Kanagawa-ken, 259-1220 JAPAN

Telephone : +81 463 50 6400

Facsimile : +81 463 50 6401

Conducted Emission Band Edge compliance

Report No. 12327685S-A
 Test place Shonan EMC Lab. No.6 Shielded Room
 Date May 24, 2018
 Temperature / Humidity 26 deg. C / 54 % RH
 Engineer Yosuke Ishikawa
 Mode Tx 3DH5

Hopping On

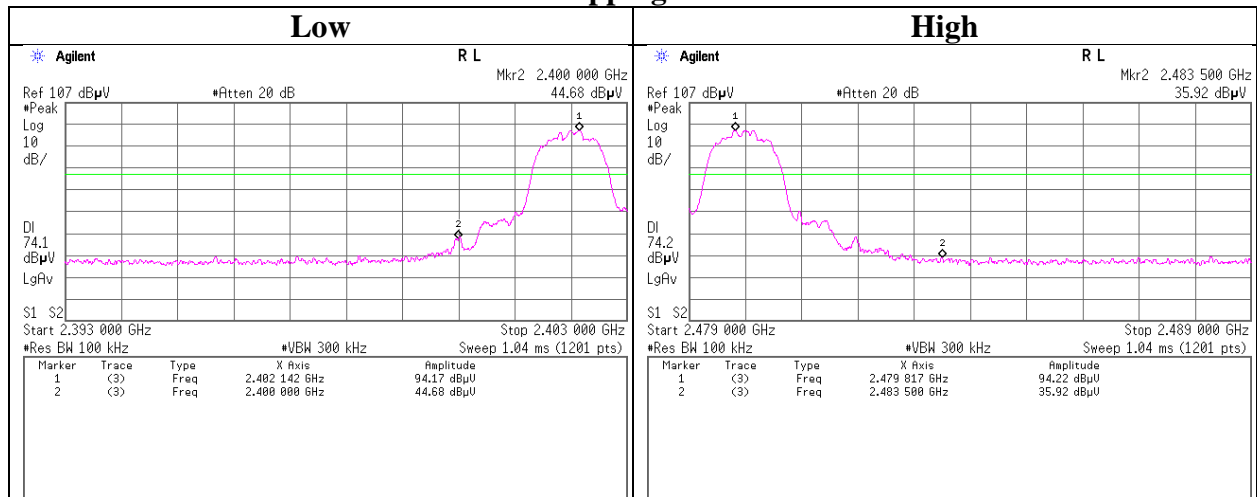

Hopping Off

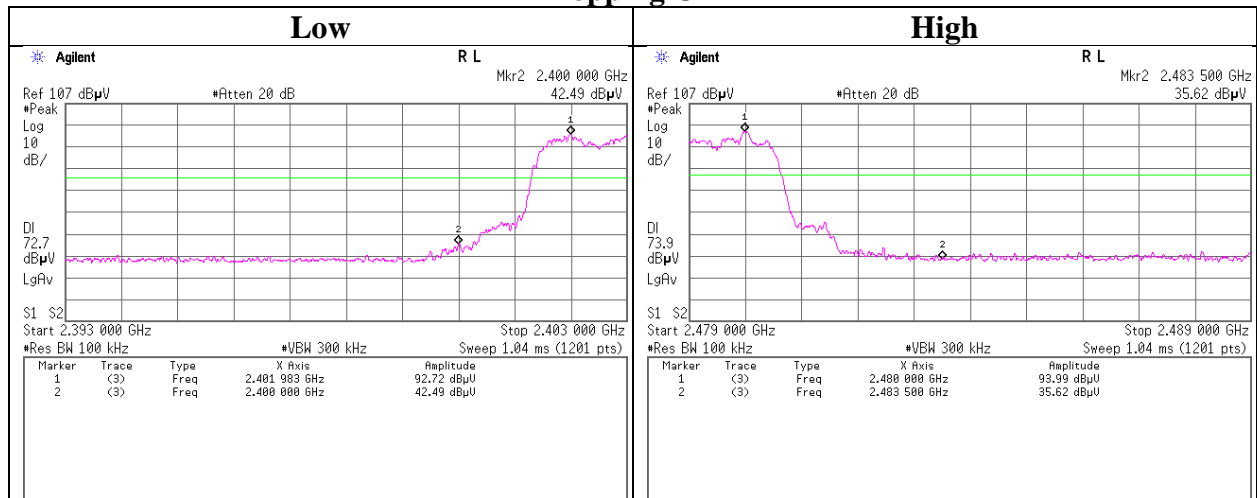

UL Japan, Inc.

Shonan EMC Lab.

1-22-3 Megumigaoka, Hiratsuka-shi, Kanagawa-ken, 259-1220 JAPAN

Telephone : +81 463 50 6400

Facsimile : +81 463 50 6401

APPENDIX 2: Test instruments

Test Instruments

Control No.	Instrument	Manufacturer	Model No	Serial No	Test Item	Calibration Date * Interval(month)
SOS-10	Humidity Indicator	A&D	AD-5681	4064561	AT	2017/10/30 * 12
SBM-11	Barometer	Sunoh	SBR121	001077	AT	2017/11/10 * 36
SJM-18	Measure	ASKUL	-	-	AT	-
STS-06	Digital Hitester	Hioki	3805-50	080997830	AT	2018/03/08 * 12
KSA-08	Spectrum Analyzer	Agilent	E4446A	MY46180525	AT, RE	2017/10/10 * 12
SPM-06	Power Meter	Anritsu	ML2495A	0850009	AT	2018/05/10 * 12
SPSS-03	Power sensor	Anritsu	MA2411B	0917063	AT	2018/05/10 * 12
SCC-G32	Coaxial Cable	Junkosha	MWX241-02000 KMSKMS	OCT-09-13-005	AT	2017/11/22 * 12
SAT10-13	Attenuator	Weinschel Corp.	54A-10	81626	AT	2018/03/19 * 12
SAEC-02(NSA)	Semi-Anechoic Chamber	TDK	SAEC-02(NSA)	2	RE	2017/06/08 * 12
SAF-02	Pre Amplifier	SONOMA	310N	290212	RE	2018/02/16 * 12
SAT6-02	Attenuator	JFW	50HF-006N	-	RE	2018/02/16 * 12
SAT3-11	Attenuator	JFW	50HF-003N	-	RE	2018/02/22 * 12
SBA-02	Biconical Antenna	Schwarzbeck	BBA9106	91032665	RE	2017/11/23 * 12
SCC-B1/B3/B5/B7/B8/B13/SRSE-02	Coaxial Cable&RF Selector	Fujikura/Fujikura/Suhner/Suhner/Suhner/TOYO	8D2W/12DSFA/141PE/141PE/141PE/141PE/NS4906	-/0901-270(RF Selector)	RE	2018/04/07 * 12
SCC-B2/B4/B6/B7/B8/B13/SRSE-02	Coaxial Cable&RF Selector	Fujikura/Fujikura/Suhner/Suhner/Suhner/TOYO	8D2W/12DSFA/141PE/141PE/141PE/141PE/NS4906	-/0901-270(RF Selector)	RE	2018/04/07 * 12
SLA-06	Logperiodic Antenna	Schwarzbeck	VUSLP9111B	195	RE	2018/01/30 * 12
SOS-03	Humidity Indicator	A&D	AD-5681	4063325	RE	2017/10/30 * 12
STR-07	Test Receiver	Rohde & Schwarz	ESU26	100484	RE	2017/09/26 * 12
SJM-09	Measure	PROMART	SEN1935	-	RE	-
COTS-SEMI-1	EMI Software	TSJ	TEPTO-DV(RE, CE,RFI,MF)	-	RE	-
STS-02	Digital Hitester	Hioki	3805-50	080997819	RE	2018/03/08 * 12
SAEC-02(SVSWR)	Semi-Anechoic Chamber	TDK	SAEC-02(SVSWR)	2	RE	2017/07/18 * 12
SHA-02	Horn Antenna	Schwarzbeck	BBHA9120D	9120D-726	RE	2017/08/14 * 12
SAJ-01	Antenna Tilt Jig	Intelligent System Engineering Co., Ltd	Antenna Tilt Jig	T-S001	RE	Pre Check
SCC-G41	Coaxial Cable	Junkosha	MWX221-01000 NFSNMS/B	1612S006	RE	2018/01/29 * 12
SCC-G44	Coaxial Cable	HUBER+SUHNER	SUCOFLEX 104	800070/4A	RE	2018/03/28 * 12
SAT10-05	Attenuator(above1G Hz)	Agilent	8493C-010	74864	RE	2017/11/22 * 12
SFL-02	Highpass Filter	MICRO-TRONICS	HPM50111	051	RE	2017/11/16 * 12
SAF-06	Pre Amplifier	TOYO Corporation	TPA0118-36	2046104	RE	2017/09/22 * 12
SCC-G43	Coaxial Cable	HUBER+SUHNER	SUCOFLEX_104_E	SN MY 13406/4E	RE	2017/07/10 * 12
SHA-04	Horn Antenna	ETS LINDGREN	3160-09	LM9861	RE	2017/07/11 * 12
SAF-08	Pre Amplifier	TOYO Corporation	HAP18-26W	00000019	RE	2018/03/27 * 12
SCC-G33	Coaxial Cable	Junkosha	MWX241-01000 KMSKMS	-	RE	2018/04/20 * 12
SCC-G15	Coaxial Cable	Suhner	SUCOFLEX 102	32703/2	RE	2018/03/19 * 12

The expiration date of the calibration is the end of the expired month.

All equipment is calibrated with valid calibrations. Each measurement data is traceable to the national or international standards.

Test item: RE: Radiated Emission test
AT: Antenna Terminal Conducted test

UL Japan, Inc.

Shonan EMC Lab.

1-22-3 Megumigaoka, Hiratsuka-shi, Kanagawa-ken, 259-1220 JAPAN

Telephone : +81 463 50 6400

Facsimile : +81 463 50 6401