



SAR TEST REPORT

Test Report No. : 12890237H-D

Applicant : Sony Corporation
Type of Equipment : UHF SYNTHESIZED TRANSMITTER
Model No. : UTX-P40
FCC ID : AK8UTXP40
Test regulation : FCC47CFR 2.1093
Test Result : Complied (Refer to SECTION 4)
Reported SAR(1g) Value : **The highest reported SAR(1g)**
Body : 0.48 W/kg

1. This test report shall not be reproduced in full or partial, without the written approval of UL Japan, Inc.
2. The results in this report apply only to the sample tested.
3. This sample tested is in compliance with the limits of the above regulation.
4. The test results in this report are traceable to the national or international standards.
5. This test report covers SAR technical requirements. It does not cover administrative issues such as Manual or non-SAR test related Requirements. (if applicable)
6. The all test items in this test report are conducted by UL Japan, Inc. Ise EMC Lab.
7. This test report must not be used by the customer to claim product certification, approval, or endorsement by NVLAP, NIST, or any agency of the Federal Government.
8. The information provided from the customer for this report is identified in SECTION 1.

Date of test: July 12 and 13, 2019

Representative test engineer: 
Hisayoshi Sato
Engineer
Consumer Technology Division

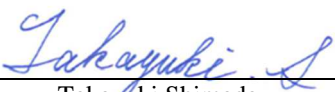
Approved by : 
Takayuki Shimada
Leader
Consumer Technology Division



This laboratory is accredited by the NVLAP LAB CODE 200572-0, U.S.A. The tests reported herein have been performed in accordance with its terms of accreditation.
*As for the range of Accreditation in NVLAP, you may refer to the WEB address,
http://japan.ul.com/resources/emc_accruited/

- The testing in which "Non-accreditation" is displayed is outside the accreditation scopes in UL Japan.
 There is no testing item of "Non-accreditation".

REVISION HISTORY

Original Test Report No.: 12890237H-D

Revision	Test report No.	Date	Page revised	Contents
- (Original)	12890237H-D	October 1, 2019	-	-

Reference: Abbreviations (Including words undescribed in this report)

A2LA	The American Association for Laboratory Accreditation	NSA	Normalized Site Attenuation
AC	Alternating Current	NVLAP	National Voluntary Laboratory Accreditation Program
AFH	Adaptive Frequency Hopping	OBW	Occupied Band Width
AM	Amplitude Modulation	OFDM	Orthogonal Frequency Division Multiplexing
Amp, AMP	Amplifier	P/M	Power meter
ANSI	American National Standards Institute	PCB	Printed Circuit Board
Ant, ANT	Antenna	PER	Packet Error Rate
AP	Access Point	PHY	Physical Layer
Atten., ATT	Attenuator	PK	Peak
AV	Average	PN	Pseudo random Noise
BPSK	Binary Phase-Shift Keying	PRBS	Pseudo-Random Bit Sequence
BR	Bluetooth Basic Rate	PSD	Power Spectral Density
BT	Bluetooth	QAM	Quadrature Amplitude Modulation
BT LE	Bluetooth Low Energy	QP	Quasi-Peak
BW	BandWidth	QPSK	Quadri-Phase Shift Keying
Cal Int	Calibration Interval	RBW	Resolution Band Width
CCK	Complementary Code Keying	RDS	Radio Data System
Ch., CH	Channel	RE	Radio Equipment
CISPR	Comite International Special des Perturbations Radioelectriques	RF	Radio Frequency
CW	Continuous Wave	RMS	Root Mean Square
DBPSK	Differential BPSK	Rx	Receiving
DC	Direct Current	SA, S/A	Spectrum Analyzer
DFS	Dynamic Frequency Selection	SG	Signal Generator
DQPSK	Differential QPSK	SVSWR	Site-Voltage Standing Wave Ratio
DSSS	Direct Sequence Spread Spectrum	TR	Test Receiver
EDR	Enhanced Data Rate	Tx	Transmitting
EIRP, e.i.r.p.	Equivalent Isotropically Radiated Power	VBW	Video BandWidth
EMC	ElectroMagnetic Compatibility	Vert.	Vertical
EMI	ElectroMagnetic Interference	WLAN	Wireless LAN
EN	European Norm		
ERP, e.r.p.	Effective Radiated Power		
EU	European Union		
EUT	Equipment Under Test		
Fac.	Factor		
FCC	Federal Communications Commission		
FHSS	Frequency Hopping Spread Spectrum		
FM	Frequency Modulation		
Freq.	Frequency		
GFSK	Gaussian Frequency-Shift Keying		
GNSS	Global Navigation Satellite System		
GPS	Global Positioning System		
Hori.	Horizontal		
IEC	International Electrotechnical Commission		
IEEE	Institute of Electrical and Electronics Engineers		
IF	Intermediate Frequency		
ILAC	International Laboratory Accreditation Conference		
ISED	Innovation, Science and Economic Development Canada		
ISO	International Organization for Standardization		
JAB	Japan Accreditation Board		
LAN	Local Area Network		
LIMS	Laboratory Information Management System		
MCS	Modulation and Coding Scheme		
MRA	Mutual Recognition Arrangement		
NIST	National Institute of Standards and Technology		
NS	No signal detect.		

UL Japan, Inc.

Ise EMC Lab.

4383-326 Asama-cho, Ise-shi, Mie-ken 516-0021 JAPAN

Telephone: +81 596 24 8999

Facsimile: +81 596 24 8124

CONTENTS	PAGE
SECTION1: Customer information.....	5
SECTION2: Equipment under test (E.U.T.).....	5
2.1 Identification of E.U.T.	5
2.2 Product description.....	5
SECTION3: Test standard information.....	7
3.1 Test Specification	7
3.2 Procedure.....	7
3.3 Additions or deviations to standard	7
3.4 Exposure limit	8
3.5 SAR	8
3.6 Test Location	8
SECTION4: Test result.....	9
4.1 Result.....	9
4.2 Stand-alone SAR result	9
SECTION5: Tune-up tolerance information and software information.....	10
SECTION6: RF Exposure Conditions (Test Configurations)	11
6.1 Summary of the distance between antenna and surface of EUT.....	11
6.2 SAR test exclusion considerations according to KDB447498 D01.....	11
6.3 Procedure for SAR test position determination	12
6.4 Test position for Body setup.....	12
SECTION7: Description of the operating mode.....	13
7.1 Output Power and SAR test required.....	13
SECTION8: Test surrounding	14
8.1 Measurement uncertainty	14
SECTION9: Parameter Check.....	15
9.1 For SAR system check	16
9.2 For SAR measurement	17
SECTION10: System Check confirmation.....	18
SECTION11: Measured and Reported (Scaled) SAR Results	19
11.1 Radio microphone	19
SECTION12: Test instruments	21
APPENDIX 1 : System Check.....	22
APPENDIX 2 : SAR Measurement data	28
APPENDIX 3 : System specifications.....	31
APPENDIX 4 : Photographs of test setup.....	123

SECTION1: Customer information

Company Name : Sony Global Manufacturing & Operations Corporation
Address : 8-4, Shiomi, Kisarazu-shi, Chiba, 292-0834 Japan
Telephone Number : +81-438-37-4704
Contact Person : Youhei Hisano

***Remarks**

Sony Global Manufacturing & Operations Corporation (Subsidiary Company Name) is on behalf of the applicant: Sony Corporation.

The information provided from the customer is as follows;

- Applicant, Type of Equipment, Model No. on the cover and other relevant pages
- Operating/Test Mode(s) (Mode(s)) on all the relevant pages
- SECTION 1: Customer information
- SECTION 2: Equipment under test (E.U.T.)
- SECTION 5: Description of the operating mode

* The laboratory is exempted from liability of any test results affected from the above information in SECTION 2 and 5.

SECTION2: Equipment under test (E.U.T.)

2.1 Identification of E.U.T.

<Information of the EUT>

Type of Equipment : UHF SYNTHESIZED TRANSMITTER
Model No. : UTX-P40
Serial No. : UC14(used for 470.125 MHz)
UC25(used for 539.000 MHz and 607.875 MHz)
UC90(used for 941.625 MHz / 950.625 MHz / 959.625 MHz)
Rating : DC 3.0 V (2 x AA Batteries) , DC 5.0V (USB)
Receipt Date of Sample : July 10, 2019
(Information from test lab.)
Country of Mass-production : Korea
Condition of EUT : Engineering prototype
(Not for Sale: This sample is equivalent to mass-produced items.)
Modification of EUT : No Modification by the test lab

2.2 Product description

Model: UTX-P40 (referred to as the EUT in this report) is a UHF SYNTHESIZED TRANSMITTER.

General Specification

Clock frequency(ies) in the system : DSP: 12 MHz (SPXO)

Radio Specification

[Radio microphone part]

Radio type	:	Transmitter
Modulation type	:	Frequency modulation
Emission designator	:	116KF3E
Necessary bandwidth	:	116 kHz = 2M + 2D where M: Maximum modulation frequency = 18 kHz D: Peak deviation = 40 kHz
Channel spacing	:	125 kHz
Frequency of operation	:	UTX-P40 (UC14) : 470.125 MHz - 541.875 MHz UTX-P40 (UC25) : 536.125 MHz - 607.875 MHz UTX-P40 (U90) : 941.625 MHz - 951.875 MHz, 953.000 MHz - 956.125 MHz, 956.625 MHz - 959.625 MHz
Clock frequency(ies)	:	PLL: 26 MHz (TCXO)
RF power	:	High: 40 mW, Low: 5 mW
Antenna type	:	1/4 Lambda Monopole antenna (integral type)
Antenna gain	:	1.5 dBi
Power Supply (radio part input)	:	DC 3.0 V, DC 5.3 V
AF Specification	:	40 Hz - 18000 Hz, Maximum input: -24 dBV (MIC level, ATT 0 dB)

SECTION3: Test standard information

3.1 Test Specification

Title : **FCC47CFR 2.1093**
Radiofrequency radiation exposure evaluation: portable devices.
: **IEEE Std 1528-2013:**
IEEE Recommended Practice for Determining the Peak Spatial-Average Specific Absorption Rate (SAR) in the Human Head from Wireless Communications Devices: Measurement Techniques.
: **Published RF exposure KDB procedures**

- KDB447498D01(v06)** RF Exposure Procedures and Equipment Authorization Policies for Mobile and Portable Devices
- KDB447498D02(v02r01)** SAR Measurement Procedures for USB Dongle Transmitters
- KDB648474D04(v01r03)** SAR Evaluation Considerations for Wireless Handsets
- KDB941225D01(v03r01)** 3G SAR Measurement Procedures
- KDB941225D05(v02r05)** SAR Evaluation Considerations for LTE Devices
- KDB941225D06(v02r01)** SAR Evaluation Procedures for Portable Devices with Wireless Router Capabilities (Hot Spot SAR)
- KDB941225D07(v01r02)** SAR Evaluation Procedures for UMPC Mini-Tablet Devices
- KDB616217D04(v01r02)** SAR Evaluation Considerations for Laptop, Notebook, Netbook and Tablet Computers
- KDB865664D01(v01r04)** SAR Measurement Requirements for 100MHz to 6 GHz
- KDB248227D01(v02r02)** SAR Guidance for 802.11(Wi-Fi) Transmitters
- KDB206256D01(v02)** Basic Certification Requirements For Wireless Microphones

Reference

[1]SPEAG uncertainty document (AN 15-7/AN19-17) for DASY 5 System from SPEAG (Schmid & Partner Engineering AG).

3.2 Procedure

Transmitter	Radio Microphone
Test Procedure	Published RF exposure KDB procedures
Category	FCC47CFR 2.1093
Note: UL Japan, Inc. 's SAR Work Procedures 13-EM-W0429 and 13-EM-W0430	

3.3 Additions or deviations to standard

Other than above, no addition, exclusion nor deviation has been made from the standard.

3.4 Exposure limit

(A) Limits for Occupational/Controlled Exposure (W/kg)

Spatial Average (averaged over the whole body)	Spatial Peak (averaged over any 1g of tissue)	Spatial Peak (hands/wrists/feet/ankles averaged over 10g)
0.4	8.0	20.0

(B) Limits for General population/Uncontrolled Exposure (W/kg)

Spatial Average (averaged over the whole body)	Spatial Peak (averaged over any 1g of tissue)	Spatial Peak (hands/wrists/feet/ankles averaged over 10g)
0.08	1.6	4.0

Occupational/Controlled Environments: are defined as locations where there is exposure that may be incurred by people who are aware of the potential for exposure, (i.e. as a result of employment or occupation).

General Population/Uncontrolled Environments: are defined as locations where there is the exposure of individuals who have no knowledge or control of their exposure.

**NOTE:GENERAL POPULATION/UNCONTROLLED EXPOSURE
SPATIAL PEAK(averaged over any 1g of tissue) LIMIT
1.6 W/kg**

3.5 SAR

Specific Absorption Rate (SAR): The time derivative (rate) of the incremental energy (dW) absorbed by (dissipated in) an incremental mass (dm) contained in a volume element (dV) of a given density (ρ), as shown in the following equation:

$$SAR = \frac{d}{dt} \left(\frac{dW}{dm} \right) = \frac{d}{dt} \left(\frac{dW}{\rho dV} \right)$$

SAR is expressed in units of watts per kilogram (W/kg) or equivalently milliwatts per gram (mW/g).

SAR is related to the E-field at a point by the following equation:

$$SAR = \frac{\sigma |E|^2}{\rho}$$

where

σ = conductivity of the tissue (S/m)
 ρ = mass density of the tissue (kg/m³)
E = rms E-field strength (V/m)

3.6 Test Location

*Shielded room for SAR testings

UL Japan, Inc. Ise EMC Lab.

NVLAP Lab. code: 200572-0 / FCC Test Firm Registration Number: 199967 / ISED SAR Lab Company Number: 2973C
4383-326 Asama-cho, Ise-shi, Mie-ken 516-0021 JAPAN

Telephone : +81 596 24 8999 Facsimile : +81 596 24 8124

UL Japan, Inc.

Ise EMC Lab.

4383-326 Asama-cho, Ise-shi, Mie-ken 516-0021 JAPAN

Telephone: +81 596 24 8999

Facsimile: +81 596 24 8124

SECTION4: Test result

4.1 Result

Complied

Highest values at each band are listed next section.

4.2 Stand-alone SAR result

Reported SAR

Measured SAR is scaled to the maximum tune-up tolerance limit by the following formulas.

Reported SAR= Measured SAR [W/kg] · Scaled factor

Maximum tune-up tolerance limit is by the specification from a customer.

* Scaled factor = Maximum tune-up tolerance limit [mW] / Measured power [mW]

Body SAR

Mode	Frequency [MHz]	Tune-up upper Power [dBm]	Measured average Power [dBm]	Maximum tune-up tolerance limit [mW]	Measured power [mW]	Measured SAR [W/kg]	Scaled factor	Reported SAR [W/kg]
Radio Microphone	607.875	16.02	14.92	40.0	31.0	0.370	1.288	0.477
Radio Microphone	950.625	16.02	14.61	40.0	28.9	0.081	1.384	0.112

Note(s):

The sample used by the SAR test is not more than 2 dB lower than the maximum tune-up tolerance limit. That is, measured power is included the tune-up tolerance range.

Maximum tune-up tolerance limit is defined as maximum timed-average value. (Considering to maximum duty cycle)

SECTION5: Tune-up tolerance information and software information

Maximum tune-up tolerance limit

Mode	Band	Maximum tune-up tolerance limit [dBm]	Maximum tune-up tolerance limit [mW]
Radio microphone	470.125 - 607.875 MHz	16.02	40.0
Radio microphone	941.625 - 959.625 MHz	16.02	40.0

Maximum tune-up tolerance limit is defined as maximum timed-average value. (Considering to maximum duty cycle)

Software setting
<p>*The power value of the EUT was set for testing as follows (setting value might be different from product specification value); Power settings: Below table. Software / version: 190415d</p> <p>*This setting of software is the worst case. The test was performed with condition that obtained the maximum average power in pre-check. Any conditions under the normal use do not exceed the condition of setting. In addition, end users cannot change the settings of the output power of the product.</p>

Mode	Frequency [MHz]	Power setting
Radio microphone	470.125	40mW
	539.000	40mW
	607.875	40mW
	941.625	40mW
	950.625	40mW
	959.625	40mW

SECTION6: RF Exposure Conditions (Test Configurations)

6.1 Summary of the distance between antenna and surface of EUT

Test position	Distance
Front	0.00 mm
Rear	0.00 mm
Right	0.00 mm
Left	0.00 mm
Top	0.00 mm
Bottom	0.00 mm

- * Details are shown in appendix 4.
- * Microphone was not connected as more conservative.

6.2 SAR test exclusion considerations according to KDB447498 D01

The following is based on KDB447498D01.

1) The 1-g and 10-g SAR test exclusion thresholds for 100 MHz to 6 GHz at test separation distances ≤ 50 mm are determined by:

$$[(\text{max. power of channel, including tune-up tolerance, mW}) / (\text{min. test separation distance, mm})] \cdot [\sqrt{f(\text{GHz})}] \leq 3.0$$

for 1-g SAR and ≤ 7.5 for 10-g extremity SAR

1. The upper frequency of the frequency band was used in order to calculate standalone SAR test exclusion considerations.
2. Power and distance are rounded to the nearest mW and mm before calculation
3. The result is rounded to one decimal place for comparison
4. The test exclusions are applicable only when the minimum test separation distance is ≤ 50 mm and for transmission frequencies between 100 MHz and 6 GHz. When the minimum test separation distance is < 5 mm, a distance of 5 mm is applied to determine SAR test exclusion. When the separation of antenna to EUT's surfaces and edges are ≤ 50 mm, the separation distance used for the SAR exclusion calculations is 5 mm.
5. "N/A" displayed on below exclusion calculation means not applicable this formula since distance between antenna and surface is > 50 mm.

When the calculated threshold value by a numerical formula above-mentioned in the following table is 3.0 or less, SAR test is excluded.

SAR exclusion calculations for antenna <50mm from the user

Antenna	Tx Interface	Frequency (MHz)	Output Power		Calculated Threshold Value					
			dBm	mW	Front	Rear	Right	Left	Top	Bottom
Fixed	Radio microphone	607.875	16.02	40	6.2	6.2	6.2	6.2	6.2	6.2
					-MEASURE-	-MEASURE-	-MEASURE-	-MEASURE-	-MEASURE-	-MEASURE-
Fixed	Radio microphone	959.625	16.02	40	7.8	7.8	7.8	7.8	7.8	7.8
					-MEASURE-	-MEASURE-	-MEASURE-	-MEASURE-	-MEASURE-	-MEASURE-

2) At 100 MHz to 6 GHz and for test separation distances > 50 mm, the SAR test exclusion threshold is determined according to the following.

- a) $[(3.50)/(\sqrt{f(\text{GHz})})] + (\text{test separation distance} - 50 \text{ mm}) \cdot (f(\text{MHz})/150) \text{ mW}$ at > 100 MHz and $\leq 1500 \text{ MHz}$
b) $[(3.50)/(\sqrt{f(\text{GHz})})] + (\text{test separation distance} - 50 \text{ mm}) \cdot 10 \text{ mW}$ at > 1500 MHz and $\leq 6 \text{ GHz}$

1. The upper frequency of the frequency band was used in order to calculate standalone SAR test exclusion considerations.
2. Power and distance are rounded to the nearest mW and mm before calculation
3. "N/A" displayed on below exclusion calculation means not applicable this formula since distance between antenna and surface is < 50 mm.

When output power is less than the calculated threshold value by a numerical formula above-mentioned in the following table, SAR test is excluded.

SAR exclusion calculations for antenna >50mm from the user

Antenna	Tx Interface	Frequency (MHz)	Output Power		Calculated Threshold Value					
			dBm	mW	Front	Rear	Right	Left	Top	Bottom
Fixed	Radio microphone	607.875	16.02	40	N/A	N/A	N/A	N/A	N/A	N/A
Fixed	Radio microphone	959.625	16.02	40	N/A	N/A	N/A	N/A	N/A	N/A

Description of the Body setup

6.3 Procedure for SAR test position determination

-The tested procedure was performed according to the KDB 447498 D01 (Mobile and Portable Device RF Exposure Procedures and Equipment Authorization Policies).

6.4 Test position for Body setup

No.	Position	Test distance	Radio microphone
			Tested
1	Front	0mm	<input checked="" type="checkbox"/>
2	Rear	0mm	<input checked="" type="checkbox"/>
3	Left	0mm	<input checked="" type="checkbox"/>
4	Right	0mm	<input checked="" type="checkbox"/>
5	Top	0mm	<input checked="" type="checkbox"/> *1
6	Bottom	0mm	<input checked="" type="checkbox"/>

*1 Top position is not a typical use of EUT, but testing is considered as a conservative SAR test mode.

SECTION7: Description of the operating mode

7.1 Output Power and SAR test required

Radio microphone

Mode	Freq. (MHz)	Tune-up upper Power (dBm)	Measured average Power (dBm)	Initial test configuration	Note(s)
Radio microphone	470.125	16.02	14.55		
	539.000	16.02	14.88	Yes	
	607.875	16.02	14.92		

Mode	Freq. (MHz)	Tune-up upper Power (dBm)	Measured average Power (dBm)	Initial test configuration	Note(s)
Radio microphone	941.625	16.02	14.68		
	950.625	16.02	14.61	Yes	
	959.625	16.02	14.54		

SECTION8: Test surrounding

8.1 Measurement uncertainty

This measurement uncertainty budget is suggested by IEEE Std 1528(2013) and IEC62209-2:2010, and determined by Schmid & Partner Engineering AG (DASY5 Uncertainty Budget). Per KDB 865664 D01 SAR Measurement 100 MHz to 6 GHz Section 2.8.1., when the highest measured SAR(1g) within a frequency band is < 1.5W/kg, the extensive SAR measurement uncertainty analysis described in IEEE Std.1528 (2013) is not required in SAR reports submitted for equipment approval.

<Body>

Error Description	Uncert. value	Prob. Dist.	Div.	(ci) 1g	(ci) 10g	Std. Unc. (1g)	Std.Unc. (10g)
Measurement System							
Probe Calibration	± 6.55 %	N	1	1	1	±6.55%	±6.55%
Axial Isotropy	± 4.7 %	R	√3	0.7	0.7	±1.9%	±1.9%
Hemispherical Isotropy	± 9.6 %	R	√3	0.7	0.7	±3.9%	±3.9%
Linearity	± 4.7 %	R	√3	1	1	±2.7%	±2.7%
Modulation Response	± 2.4 %	R	√3	1	1	±1.4%	±1.4%
System Detection Limits	± 1.0 %	R	√3	1	1	±0.6%	±0.6%
Boundary Effects	± 2.0 %	R	√3	1	1	±1.2%	±1.2%
Readout Electronics	± 0.3 %	N	1	1	1	±0.3%	±0.3%
Response Time	± 0.8 %	R	√3	1	1	±0.5%	±0.5%
Integration Time	± 2.6 %	R	√3	1	1	±1.5%	±1.5%
RF Ambient Noise	± 3.0 %	R	√3	1	1	±1.7%	±1.7%
RF Ambient Reflections	± 3.0 %	R	√3	1	1	±1.7%	±1.7%
Probe Positioner	± 0.04 %	R	√3	1	1	±0.0%	±0.0%
Probe Positioning	± 0.8 %	R	√3	1	1	±0.5%	±0.5%
Post-processing	± 4.0 %	R	√3	1	1	±2.3%	±2.3%
Test Sample Related							
Device Holder	± 3.6 %	N	1	1	1	±3.6%	±3.6%
Test sample Positioning	± 2.9 %	N	1	1	1	±2.9%	±2.9%
Power Scaling	± 0.0 %	R	√3	1	1	±0.0%	±0.0%
Power Drift	± 5.0 %	R	√3	1	1	±2.9%	±2.9%
Phantom and Setup							
Phantom Uncertainty	± 7.6 %	R	√3	1	1	±4.4%	±4.4%
SAR correction	± 1.9 %	N	1	1	0.84	±1.9%	±1.6%
Liquid Conductivity (mea.)	+ 2.6 %	N	1	0.78	0.71	±2.0%	±1.9%
Liquid Permittivity (mea.)	- 3.8 %	N	1	0.23	0.26	±0.9%	±1.0%
Temp. unc. - Conductivity	± 3.4 %	R	√3	0.78	0.71	±1.5%	±1.4%
Temp. unc. - Permittivity	± 0.4 %	R	√3	0.23	0.26	±0.1%	±0.1%
Combined Std. Uncertainty						±12.1%	±12.0%
Expanded STD Uncertainty (κ =2)						±24.2%	±24.1%

Note: This uncertainty budget for validation is worst-case. Table of uncertainties are listed for ISO/IEC 17025.

SECTION9: Parameter Check

The dielectric parameters were checked prior to assessment using the DAK dielectric probe kit.
The dielectric parameters measurement is reported in each correspondent section.

According to KDB865664 D01, +/- 5% tolerances are required for ϵ_r and σ and then below table which is the target value of the simulated tissue liquid is quoted from KDB865664 D01.

Target Frequency (MHz)	Head		Body	
	ϵ_r	σ (S/m)	ϵ_r	σ (S/m)
150	52.3	0.76	61.9	0.80
300	45.3	0.87	58.2	0.92
450	43.5	0.87	56.7	0.94
835	41.5	0.90	55.2	0.97
900	41.5	0.97	55.0	1.05
915	41.5	0.98	55.0	1.06
1450	40.5	1.20	54.0	1.30
1610	40.3	1.29	53.8	1.40
1800 – 2000	40.0	1.40	53.3	1.52
2450	39.2	1.80	52.7	1.95
3000	38.5	2.40	52.0	2.73
5800	35.3	5.27	48.2	6.00

(ϵ_r = relative permittivity, σ = conductivity and $\rho = 1000 \text{ kg/m}^3$)

Abbreviations and remarks for the liquid data

σ : Conductivity / ϵ_r : Relative Permittivity

*1 The Target value is a parameter defined in KDB 865664D01.

*2 The dielectric parameters should be linearly interpolated between the closest pair of target frequencies to determine the applicable dielectric parameters corresponding to the device test frequency.

9.1 For SAR system check

DIELECTRIC PARAMETERS MEASUREMENT RESULTS											
Date	Ambient Temp. [deg.c]	Relative Humidity [%]	Liquid type	Liquid Temp. [deg.c]	Measured Frequency [MHz]	Parameters	Target Value	Measured	Deviation [%]	Limit [%]	Remark
2019/7/13	24.0	50	HBBL600-10000	23.5	450	σ [mho/m]	0.87	0.89	2.0	+/-5	*1
						ϵ_r	43.5	42.1	-3.3	+/-5	
2019/7/13	24.0	50	HBBL600-10000	23.5	600	σ [mho/m]	0.88	0.91	2.6	+/-5	*2
						ϵ_r	42.7	41.1	-3.8	+/-5	
2019/7/12	24.0	48	HBBL600-10000	23.5	900	σ [mho/m]	0.97	0.99	2.0	+/-5	*1
						ϵ_r	41.5	40.2	-3.0	+/-5	

Correlation confirmation with measured TSL parameters of the calibration certificate of system check dipoles (Refer to Appendix 3)

+/- 6% limit for deviation provided by manufacture tolerances are required for ϵ_r and σ and then below table which is the target value of the simulated tissue liquid is quoted from data measured TSL parameters of dipole calibration.

Freq [MHz]	Model,S/N	Head	
		σ	ϵ_r
450	D450,1051	0.87	44.4
600	D600,1003	0.87	41.5
900	D900,1d168	0.94	40.6

DIELECTRIC PARAMETERS MEASUREMENT RESULTS											
Date	Ambient Temp. [deg.c]	Relative Humidity [%]	Liquid type	Liquid Temp. [deg.c]	Measured Frequency [MHz]	Parameters	Target Value*1	Measured	Deviation [%]	Limit [%]	Remark
2019/7/13	24.0	50	HSL450	23.5	450	σ [mho/m]	0.87	0.89	2.0	+/-6	
						ϵ_r	44.4	42.1	-5.3	+/-6	
2019/7/13	24.0	50	HBBL600-10000	23.5	600	σ [mho/m]	0.87	0.91	4.0	+/-6	
						ϵ_r	41.5	41.1	-1.0	+/-6	
2019/7/12	24.0	48	HBBL600-10000	23.5	900	σ [mho/m]	0.94	0.99	5.3	+/-6	
						ϵ_r	40.6	40.2	-0.9	+/-6	

9.2 For SAR measurement

DIELECTRIC PARAMETERS MEASUREMENT RESULTS											
Date	Ambient Temp. [deg.c]	Relative Humidity [%]	Liquid type	Liquid Temp. [deg.c]	Measured Frequency [MHz]	Parameters	Target Value	Measured	Deviation [%]	Limit [%]	Remark
2019/7/13	24.0	50	HSL450	23.5	470.125	σ [mho/m]	0.87	0.89	1.8	+/-5	*2
						ϵ_r	43.4	41.9	-3.5	+/-5	
2019/7/13	24.0	50	HSL450	23.5	539	σ [mho/m]	0.88	0.90	2.1	+/-5	*2
						ϵ_r	43.0	41.5	-3.6	+/-5	
2019/7/13	24.0	50	HBBL600-10000	23.5	607.875	σ [mho/m]	0.88	0.91	2.6	+/-5	*2
						ϵ_r	42.7	41.0	-3.8	+/-5	
2019/7/12	24.0	48	HBBL600-10000	23.5	941.625	σ [mho/m]	0.99	1.01	2.3	+/-5	*2
						ϵ_r	41.5	40.0	-3.4	+/-5	
2019/7/12	24.0	48	HBBL600-10000	23.5	950.625	σ [mho/m]	0.99	1.02	2.3	+/-5	*2
						ϵ_r	41.4	40.0	-3.4	+/-5	
2019/7/12	24.0	48	HBBL600-10000	23.5	959.625	σ [mho/m]	1.00	1.02	2.6	+/-5	*2
						ϵ_r	41.4	39.9	-3.5	+/-5	

SECTION10: System Check confirmation

The measurements were performed in the flat section of the TWIN SAM or ELI phantom, shell thickness: 2.0 ±0.2 mm (bottom plate) filled with Body or Head simulating liquid of the following parameters.

The depth of tissue-equivalent liquid in a phantom must be ≥ 15.0 cm ± 0.5 cm for SAR measurements ≤ 3 GHz and ≥ 10.0 cm ± 0.5 cm for measurements > 3 GHz.

The DASY system with an E-Field Probe was used for the measurements.

The dipole was mounted on the small tripod so that the dipole feed point was positioned below the center marking of the flat phantom section and the dipole was oriented parallel to the body axis (the long side of the phantom).

The standard measuring distance was 10 mm (above 1GHz to 6GHz) and 15 mm (below 1GHz) from dipole center to the simulating liquid surface.

The coarse grid with a grid spacing of 12 mm (1GHz to 3GHz) and 15 mm (below 1GHz) was aligned with the dipole.

For 5 GHz band - The coarse grid with a grid spacing of 10 mm was aligned with the dipole.

Special 7x7x7 (below 3 GHz) and/or 8x8x7 (above 3 GHz) fine cube was chosen for the cube.

Distance between probe sensors and phantom surface was set to 3 mm.

For 5 GHz band - Distance between probe sensors and phantom surface was set to 2.5 mm

The dipole input power (forward power) was 100 mW(For 5GHz band) or 250 mW(For other band).

The results are normalized to 1 W input power.

Target Value

Freq [MHz]	Model,S/N	Head	
		(SPEAG) 1g [W/kg]	(SPEAG) 10g[W/kg]
450	D450,1051	4.48	3.00
600	D600,1003	6.44	4.20
900	D900,1d168	10.52	6.72

Date Tested	Test Freq	Model,S/N	T.S. Liquid	Measured Results		Target (Ref. Value)	Delta ±10 %	
				Zoom Scan	Normalize to 1 W			
2019/7/13	450	D450,1051	Head	1g	1.19	4.8	4.48	6.2
				10g	0.79	3.2	3.00	5.3
2019/7/13	600	D600,1003	Head	1g	1.73	6.9	6.44	7.5
				10g	1.13	4.52	4.20	7.6
2019/7/12	900	D900,1d168	Head	1g	2.69	10.8	10.52	2.3
				10g	1.71	6.84	6.72	1.8

* The target(reference) SAR values can be obtained from the calibration certificate of system validation dipoles(Refer to Appendix 3). The target SAR values are SAR measured value in the calibration certificate scaled to 1W.

SECTION11: Measured and Reported (Scaled) SAR Results

SAR Test Reduction criteria are as follows

● **KDB 447498 D01 (General RF Exposure Guidance):**

Testing of other required channels within the operating mode of a frequency band is not required when the reported 1-g or 10-g SAR for the mid-band or highest output power channel is:

- ◇ ≤ 0.8 W/kg or 2.0 W/kg, for 1-g or 10-g respectively, when the transmission band is ≤ 100 MHz
- ◇ ≤ 0.6 W/kg or 1.5 W/kg, for 1-g or 10-g respectively, when the transmission band is between 100 MHz and 200 MHz
- ◇ ≤ 0.4 W/kg or 1.0 W/kg, for 1-g or 10-g respectively, when the transmission band is ≥ 200 MHz

- According to Notice 2016-DRS001 based on the IEEE1528 and IEC 62209 requirements, the low, mid and high frequency channels for the configuration with the highest SAR value must be tested regardless of the SAR value measured.
- When reported SAR value is exceed 1.2W/kg(if any), device holder perturbation verification is required; however, since distance between device holder and antenna of EUT is enough, it was not conducted.
- Reported SAR= Measured SAR [W/kg] · Scaled factor
* Scaled factor = Maximum tune-up tolerance limit [mW] / Measured power [mW]
- Maximum tune-up tolerance limit is by the specification from a customer.

11.1 Radio microphone

Test Position	Dist. (mm)	Freq. (MHz)	Power (dBm)		Scaled factor	1-g SAR (W/kg)		Plot No.
			Tune-up upper Power	Measured average Power		Meas.	Reported	
Front	0	470.125	16.02	14.55	1.403			
		539.000	16.02	14.88	1.300	0.041	0.053	
		607.875	16.02	14.92	1.288			
Rear	0	470.125	16.02	14.55	1.403			
		539.000	16.02	14.88	1.300	0.073	0.095	
		607.875	16.02	14.92	1.288			
Right	0	470.125	16.02	14.55	1.403			
		539.000	16.02	14.88	1.300	0.143	0.186	
		607.875	16.02	14.92	1.288			
Left	0	470.125	16.02	14.55	1.40			
		539.000	16.02	14.88	1.30	0.159	0.207	
		607.875	16.02	14.92	1.29			
Top	0	470.125	16.02	14.55	1.403	0.292	0.410	
		539.000	16.02	14.88	1.300	0.199	0.259	
		607.875	16.02	14.92	1.288	0.370	0.477	1
Bottom	0	470.125	16.02	14.55	1.40			
		539.000	16.02	14.88	1.30	0.012	0.016	
		607.875	16.02	14.92	1.29			

Test Position	Dist. (mm)	Freq. (MHz)	Power (dBm)		Scaled factor	1-g SAR (W/kg)		Plot No.
			Tune-up upper Power	Measured average Power		Meas.	Reported	
Front	0	941.625	16.02	14.68	1.362			
		950.625	16.02	14.61	1.384	0.033	0.046	
		959.625	16.02	14.54	1.406			
Rear	0	941.625	16.02	14.68	1.362			
		950.625	16.02	14.61	1.384	0.059	0.082	
		959.625	16.02	14.54	1.406			
Right	0	941.625	16.02	14.68	1.362			
		950.625	16.02	14.61	1.384	0.068	0.094	
		959.625	16.02	14.54	1.406			
Left	0	941.625	16.02	14.68	1.362	0.078	0.106	
		950.625	16.02	14.61	1.384	0.081	0.112	2
		959.625	16.02	14.54	1.406	0.069	0.097	
Top	0	941.625	16.02	14.68	1.362			
		950.625	16.02	14.61	1.384	0.063	0.087	
		959.625	16.02	14.54	1.406			
Bottom	0	941.625	16.02	14.68	1.362			
		950.625	16.02	14.61	1.384	0.004	0.006	
		959.625	16.02	14.54	1.406			

SECTION12: Test instruments

Control No.	Instrument	Manufacturer	Model No	Serial No	Test Item	Calibration Date * Interval(month)
MDA-09	Dipole Antenna	Schmid&Partner Engineering AG	D450V3	1051	SAR	2018/09/10 * 12
A2588	Dipole Antenna	Schmid&Partner Engineering AG	D900V2	1d168	SAR(D900)	2018/09/18 * 12
MDA-21	Dipole Antenna	Schmid&Partner Engineering AG	D600V3	1003	SAR(D600)	2016/09/19 * 36
COTS-MSAR-03	Dasy5	Schmid&Partner Engineering AG	DASY5	-	SAR	-
MHBBL600-10000	Head Simulating Liquid	Schmid&Partner Engineering AG	SL AAH U16 BC	-	SAR	Pre Check
MNA-03	Vector Reflectometer	Copper Mountain Technologies	PLANAR R140	0030913	SAR	2019/04/01 * 12
MDPK-03	Dielectric assessment kit	Schmid&Partner Engineering AG	DAK-3.5	0008	SAR	2019/04/09 * 12
MOS-37	Digital thermometer	LKM electronic	DTM3000	-	SAR	2019/07/03 * 12
COTS-MSAR-04	Dielectric assessment software	Schmid&Partner Engineering AG	DAK	-	SAR	-
MDAE-02	Data Acquisition Electronics	Schmid&Partner Engineering AG	DAE4	1369	SAR	2019/05/08 * 12
MPB-08	Dosimetric E-Field Probe	Schmid&Partner Engineering AG	EX3DV4	3917	SAR	2019/05/15 * 12
A2436	Dosimetric E-Field Probe	Schmid&Partner Engineering AG	ES3DV3	3335	SAR	2018/07/26 * 12
MPF-03	2mm Oval Flat Phantom	Schmid&Partner Engineering AG	QDOVA001BB	1203	SAR	2019/05/14 * 12
MDH-04	Device holder	Schmid&Partner Engineering AG	Mounting device for transmitter	-	SAR	Pre Check
MOS-35	Digital thermometer	HANNA	Checktemp 4	-	SAR	2019/07/03 * 12
MRBT-03	SAR robot	Schmid&Partner Engineering AG	TX60 Lspeag	F13/5PPLD1/A/01	SAR	2019/04/26 * 12
MPM-11	Dual Power Meter	Agilent	E4419B	MY45102060	SAR	2018/08/07 * 12
MPSE-15	Power sensor	Agilent	E9301A	MY41498311	SAR	2018/08/07 * 12
MPSE-16	Power sensor	Agilent	E9301A	MY41498313	SAR	2018/08/07 * 12
MRFA-24	Pre Amplifier	R&K	R&K CGA020M602-2633R	B30550	SAR	2019/06/17 * 12
MSG-10	Signal Generator	Agilent	N5181A	MY47421098	SAR	2018/11/14 * 12
MAT-78	Attenuator	Telegartner	J01156A0011	0042294119	SAR	Pre Check
MAT-81	Attenuator	Weinschel Associates	WA1-20-33	100131	SAR	2019/04/02 * 12
MPSE-24	Power sensor	Anritsu Limited	MA24106A	1026164	SAR	2018/08/07 * 12
COTS-MPSE-02	Software for MA24106A	Anritsu Limited	Anritsu PowerXpert	-	SAR	-
MHDC-21	Dual Directional Coupler	Agilent	778D	MY52180243	SAR (0.1-2GHz)	Pre Check

The expiration date of the calibration is the end of the expired month.

All equipment is calibrated with valid calibrations. Each measurement data is traceable to the national or international standards.

As for some calibrations performed after the tested dates, those test equipment have been controlled by means of an unbroken chains of calibrations.

SAR room is checked before every testing and ambient noise is <0.012W/kg

APPENDIX 1 : System Check

System check result Body

20190713 450MHz System Check

Communication System: UID 0, CW (0); Communication System Band: D450 (450.0 MHz); Frequency: 450 MHz; Duty Cycle: 1:1

Medium parameters used: $f = 450$ MHz; $\sigma = 0.887$ S/m; $\epsilon_r = 42.063$; $\rho = 1000$ kg/m³

Phantom section: Flat Section

Measurement Standard: DASYS (IEEE/IEC/ANSI C63.19-2007)

DASY5 Configuration

Probe: EX3DV4 - SN3917; ConvF(11.3, 11.3, 11.3) @ 450 MHz; Calibrated: 2019/05/15

Sensor-Surface: 1.4mm (Mechanical Surface Detection), Sensor-Surface: 0mm (Fix Surface)

Electronics: DAE4 Sn1369; Calibrated: 2019/05/08

Phantom: ELI v5.0 (20deg probe tilt); Type: QDOVA001BB; Serial: TP:1203

Measurement SW: DASYS2, Version 52.10 (2); SEMCAD X Version 14.6.12 (7450)

Pin/250mW/Area Scan (61x61x1): Interpolated grid: dx=1.500 mm, dy=1.500 mm

Maximum value of SAR (interpolated) = 1.61 W/kg

Pin/250mW/Zoom Scan (7x7x7) (7x7x7)/Cube 0: Measurement grid: dx=5mm, dy=5mm, dz=5mm

Reference Value = 43.90 V/m; Power Drift = 0.05 dB

Peak SAR (extrapolated) = 1.92 W/kg

SAR(1 g) = 1.19 W/kg; SAR(10 g) = 0.789 W/kg

Maximum value of SAR (measured) = 1.64 W/kg

Pin/250mW/Z Scan (1x1x31): Measurement grid: dx=20mm, dy=20mm, dz=5mm

Maximum value of SAR (measured) = 1.02 W/kg

Date: 2019/07/13

Ambient Temp. : 24.0 degree.C. Liquid Temp.; 23.5 degree.C.

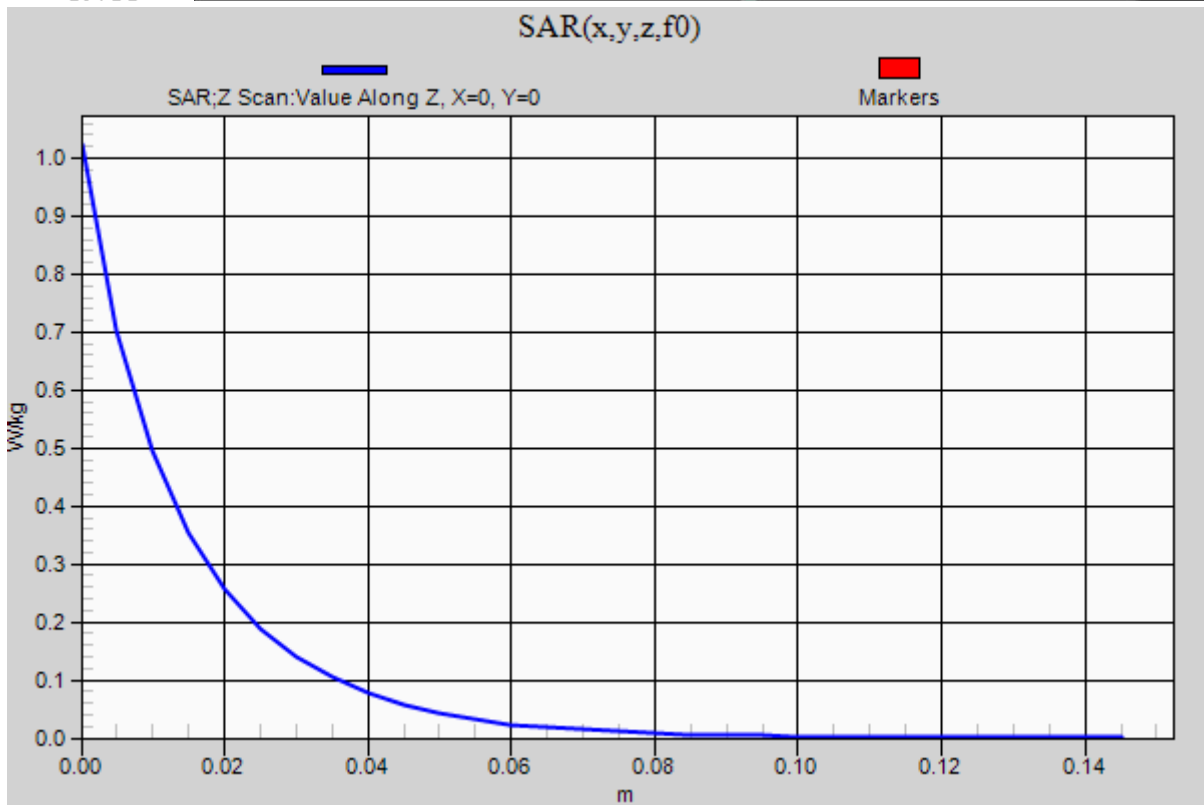
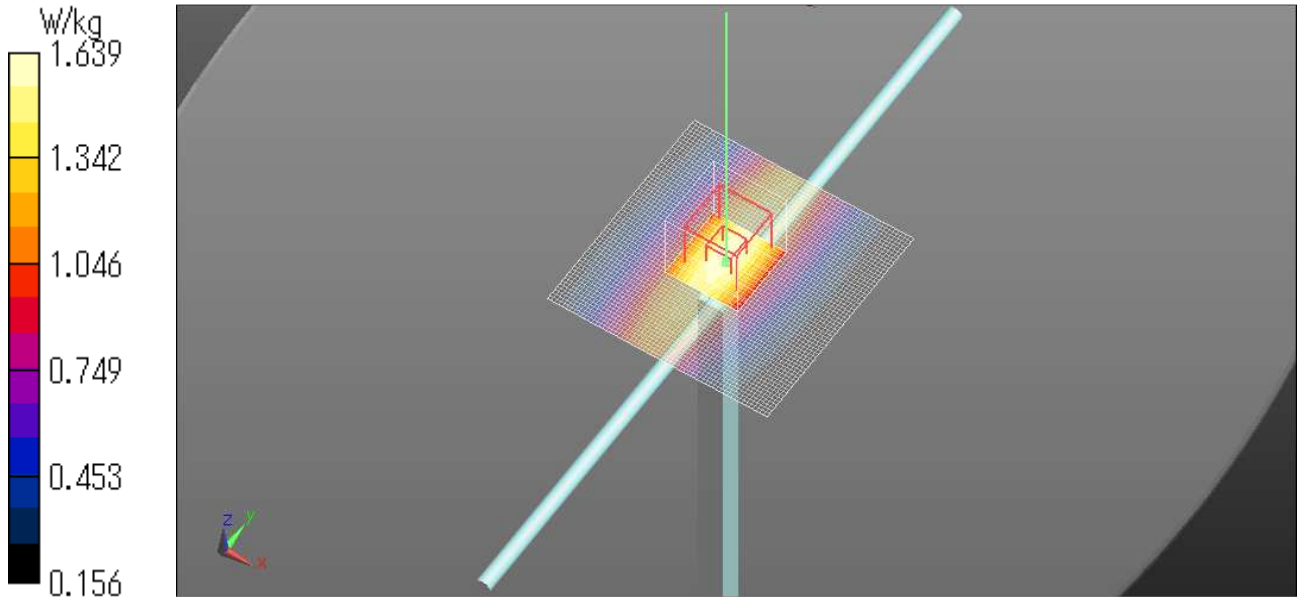

20190713 600MHz System Check

Communication System: UID 0, #CW (0); Communication System Band: D600 (600.0 MHz); Frequency: 600 MHz; Duty Cycle: 1:1

Medium parameters used: $f = 600$ MHz; $\sigma = 0.905$ S/m; $\epsilon_r = 41.08$; $\rho = 1000$ kg/m³

Phantom section: Flat Section

Measurement Standard: DASYS5 (IEEE/IEC/ANSI C63.19-2007)

DASY5 Configuration

Probe: EX3DV4 - SN3917; ConvF(10.38, 10.38, 10.38) @ 600 MHz; Calibrated: 2019/05/15

Sensor-Surface: 1.4mm (Mechanical Surface Detection), Sensor-Surface: 0mm (Fix Surface)

Electronics: DAE4 Sn1369; Calibrated: 2019/05/08

Phantom: ELI v5.0 (20deg probe tilt); Type: QDOVA001BB; Serial: TP:1203

Measurement SW: DASYS52, Version 52.10 (2); SEMCAD X Version 14.6.12 (7450)

Pin/250mW/Area Scan (61x61x1): Interpolated grid: dx=1.500 mm, dy=1.500 mm

Maximum value of SAR (interpolated) = 2.36 W/kg

Pin/250mW/Zoom Scan (7x7x7) (7x7x7)/Cube 0: Measurement grid: dx=5mm, dy=5mm, dz=5mm

Reference Value = 52.08 V/m; Power Drift = 0.03 dB

Peak SAR (extrapolated) = 2.87 W/kg

SAR(1 g) = 1.73 W/kg; SAR(10 g) = 1.13 W/kg

Maximum value of SAR (measured) = 2.42 W/kg

Pin/250mW/Z Scan (1x1x31): Measurement grid: dx=20mm, dy=20mm, dz=5mm

Maximum value of SAR (measured) = 0.999 W/kg

Date: 2019/07/13

Ambient Temp. : 24.0 degree.C. Liquid Temp.; 23.5 degree.C.

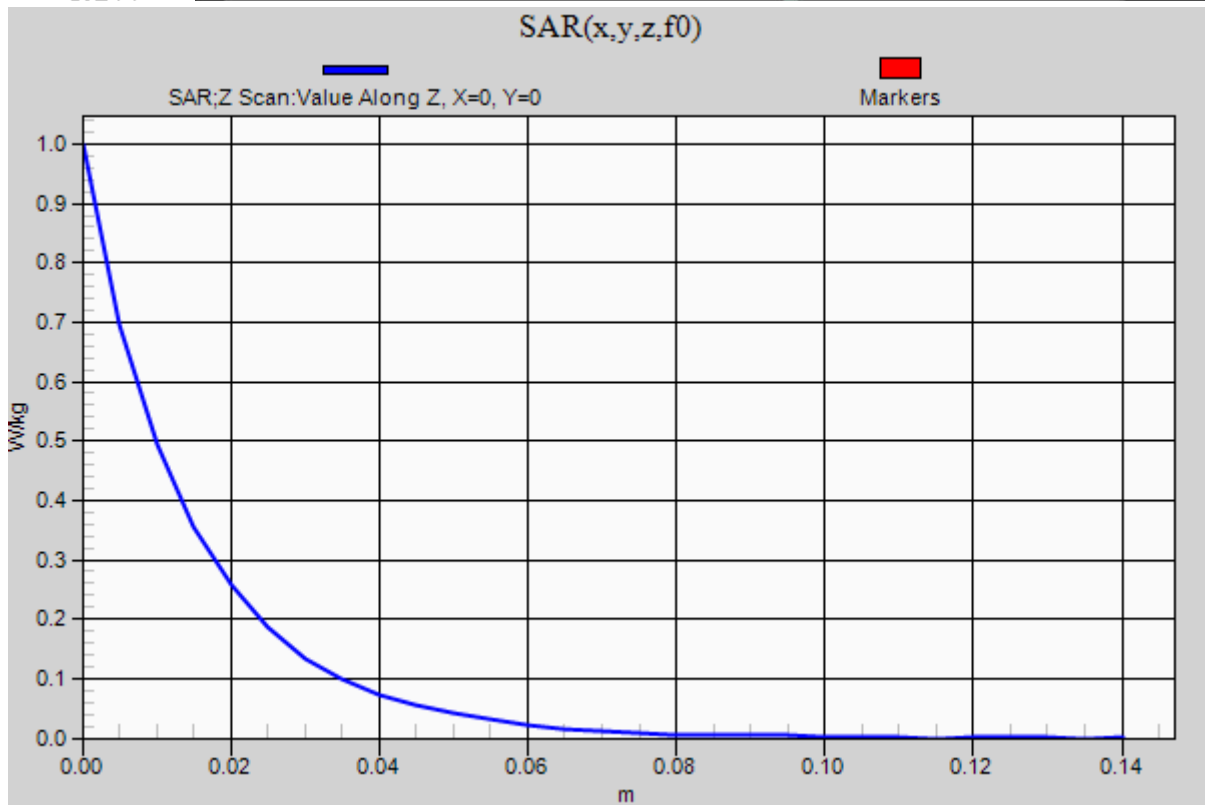
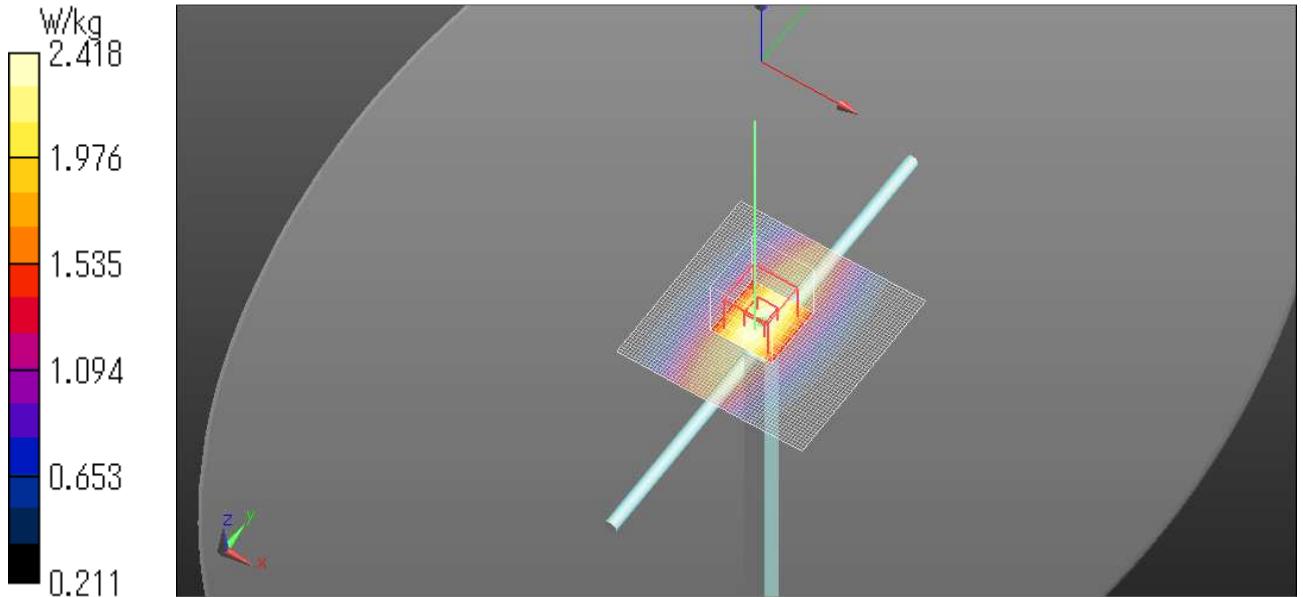

20190712 Head 900MHz System Check

Communication System: UID 0, #CW (0); Communication System Band: D900 (900.0 MHz); Frequency: 900 MHz; Duty Cycle: 1:1

Medium parameters used: $f = 900$ MHz; $\sigma = 0.99$ S/m; $\epsilon_r = 40.235$; $\rho = 1000$ kg/m³

Phantom section: Flat Section

Measurement Standard: DASYS (IEEE/IEC/ANSI C63.19-2007)

DASY5 Configuration

Probe: ES3DV3 - SN3335; ConvF(6.31, 6.31, 6.31) @ 900 MHz; Calibrated: 2018/07/26

Sensor-Surface: 3mm (Mechanical Surface Detection), Sensor-Surface: 0mm (Fix Surface)

Electronics: DAE4 Sn1369; Calibrated: 2019/05/08

Phantom: ELI v5.0 (20deg probe tilt); Type: QDOVA001BB; Serial: TP:1203

Measurement SW: DASYS2, Version 52.10 (2); SEMCAD X Version 14.6.12 (7450)

Pin/250mW/Area Scan (61x61x1): Interpolated grid: dx=1.500 mm, dy=1.500 mm

Maximum value of SAR (interpolated) = 3.11 W/kg

Pin/250mW/Zoom Scan (7x7x7) (7x7x7)/Cube 0: Measurement grid: dx=5mm, dy=5mm, dz=5mm

Reference Value = 58.38 V/m; Power Drift = 0.07 dB

Peak SAR (extrapolated) = 4.13 W/kg

SAR(1 g) = 2.69 W/kg; SAR(10 g) = 1.71 W/kg

Maximum value of SAR (measured) = 3.17 W/kg

Pin/250mW/Z Scan (1x1x31): Measurement grid: dx=20mm, dy=20mm, dz=5mm

Maximum value of SAR (measured) = 2.08 W/kg

Date: 2019/07/12

Ambient Temp. : 24.0 degree.C. Liquid Temp.; 23.5 degree.C.

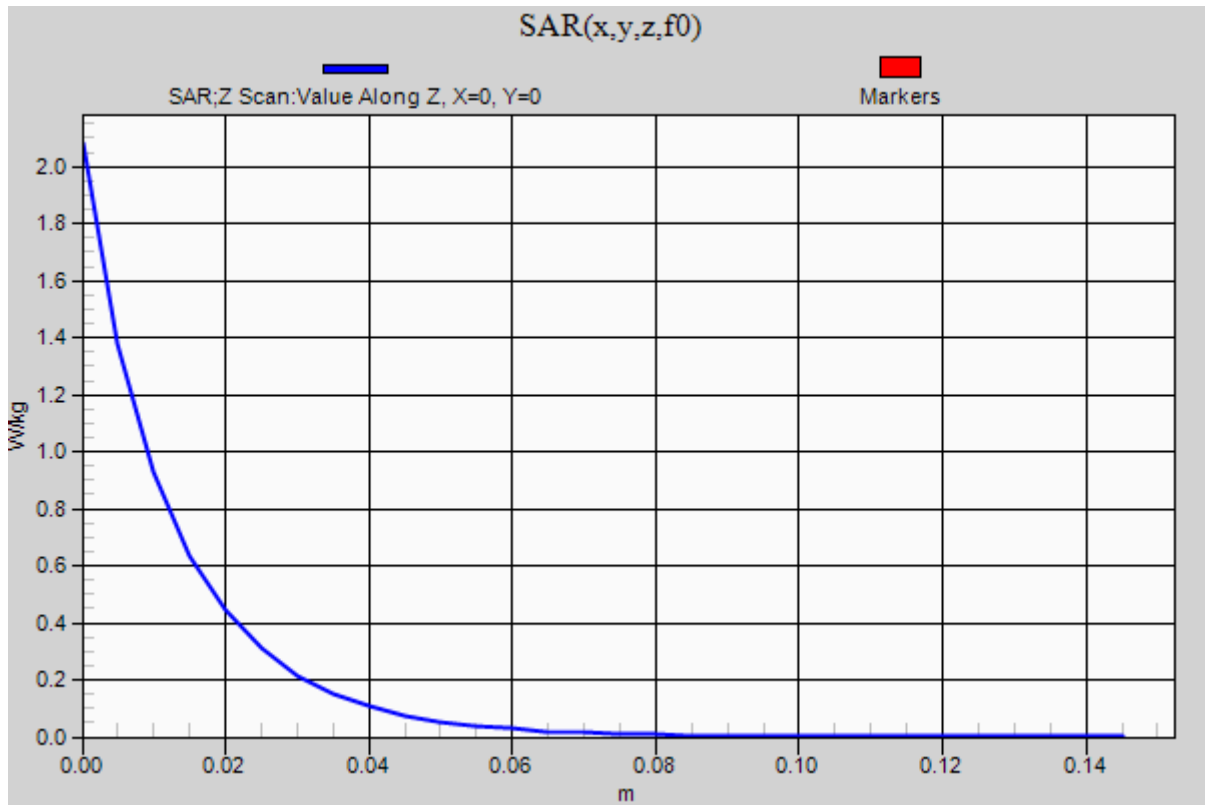
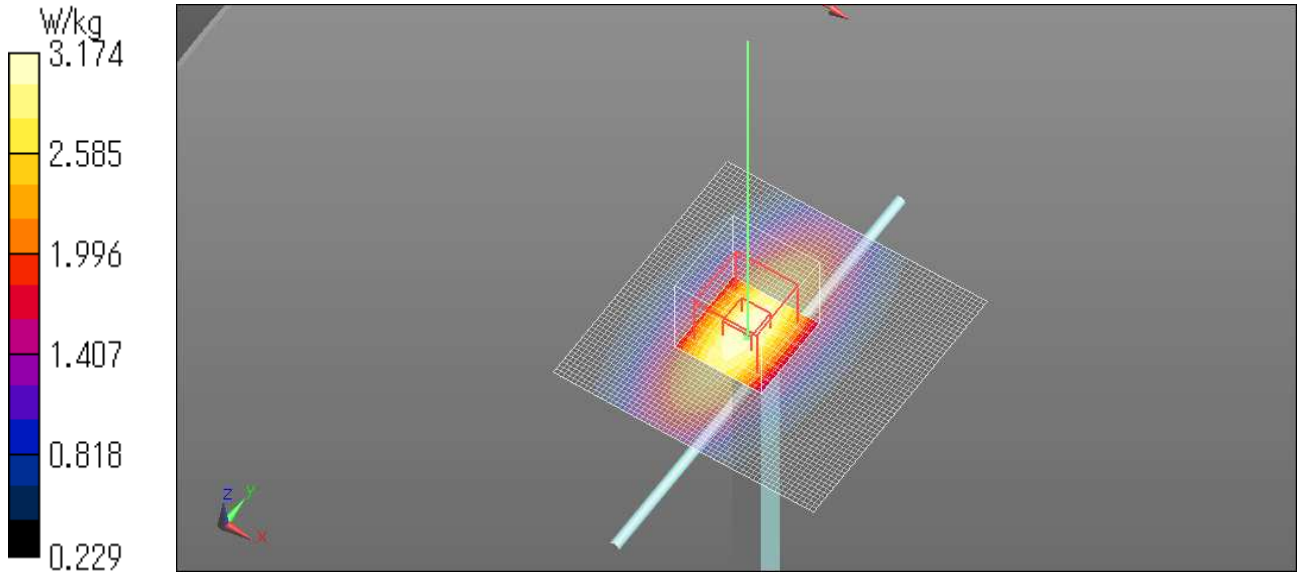

APPENDIX 2 : SAR Measurement data

Evaluation procedure

The evaluation was performed with the following procedure:

Step 1: Measurement of the E-field at a fixed location above the ear point or central position of flat phantom was used as a reference value for assessing the power drop.

Step 2: The SAR distribution at the exposed side of head or body position was measured at a distance of each device from the inner surface of the shell. The area covered the entire dimension of the antenna of EUT and the horizontal grid spacing was 15 mm x 15 mm, 12 mm x 12 mm or 10mm x 10mm. Based on these data, the area of the maximum absorption was determined by spline interpolation.

Step 3: Around this point found in the Step 2 (area scan), a volume of 30mm x 30mm x 30mm or more was assessed by measuring 7 x 7 x 7 points at least for below 3GHz and a volume of 28 mm x 28mm x 22.5mm or more was assessed by measuring 8 x 8 x 6(ratio step method (*1)) points at least for 5GHz band.

And for any secondary peaks found in the Step2 which are within 2dB of maximum peak and not with this Step3 (Zoom scan) is repeated. On the basis of this data set, the spatial peak SAR value was evaluated under the following procedure:

(1). The data at the surface were extrapolated, since the center of the dipoles is 1mm(EX3DV4) away from the tip of the probe and the distance between the surface and the lowest measuring point is 1.3 mm. The extrapolation was based on a least square algorithm [4]. A polynomial of the fourth order was calculated through the points in z-axes.

This polynomial was then used to evaluate the points between the surface and the probe tip.

(2). The maximum interpolated value was searched with a straightforward algorithm. Around this maximum the SAR values averaged over the spatial volumes (1 g or 10 g) were computed by the 3D-Spline interpolation algorithm. The 3D-Spline is composed of three one-dimensional splines with the "Not a knot"-condition (in x, y and z-directions) [4], [5]. The volume was integrated with the trapezoidal-algorithm. One thousand points (10 x 10 x 10) were interpolated to calculate the average.

(3). All neighboring volumes were evaluated until no neighboring volume with a higher average value was found.

***1. Ratio step method parameters used;**

The first measurement point: 2mm from the phantom surface, the initial grid separation: 2mm, subsequent graded grid ratio: 1.5

These parameters comply with the requirement of the KDB 865664D01.

Step 4: Re-measurement of the E-field at the same location as in Step 1.

Confirmation after SAR testing

It was checked that the power drift [W] is within +/-5%. The verification of power drift during the SAR test is that DASY5 system calculates the power drift by measuring the e-filed at the same location at beginning and the end of the scan measurement for each test position.

DASY5 system calculation Power drift value[dB] = $20\log(E_a)/(E_b)$

Before SAR testing : $E_b[V/m]$

After SAR testing : $E_a[V/m]$

Limit of power drift[W] = +/-5%

$X[dB]=10\log[P]=10\log(1.05/1)=10\log(1.05)-10\log(1)=0.212dB$

from E-filed relations with power.

$p=E^2/\eta=E^2/$

Therefore, The correlation of power and the E-filed

$XdB=10\log(P)=10\log(E)^2=20\log(E)$

Therefore,

The calculated power drift of DASY5 System must be the less than +/-0.212dB.

UL Japan, Inc.

Ise EMC Lab.

4383-326 Asama-cho, Ise-shi, Mie-ken 516-0021 JAPAN

Telephone: +81 596 24 8999

Facsimile: +81 596 24 8124

Measurement data

Plot No. 1

Radio Microphone Front 0mm 607.875MHz

Communication System: UID 0, Radio microphone (0); Communication System Band: UC; Frequency: 607.875 MHz; Duty Cycle: 1:1

Medium parameters used (interpolated): $f = 607.875$ MHz; $\sigma = 0.905$ S/m; $\epsilon_r = 41.041$; $\rho = 1000$ kg/m³

Phantom section: Flat Section

Measurement Standard: DASYS (IEEE/IEC/ANSI C63.19-2007)

DASY5 Configuration

Probe: EX3DV4 - SN3917; ConvF(10.38, 10.38, 10.38) @ 607.875 MHz; Calibrated: 2019/05/15

Sensor-Surface: 1.4mm (Mechanical Surface Detection)

Electronics: DAE4 Sn1369; Calibrated: 2019/05/08

Phantom: ELI v5.0 (20deg probe tilt); Type: QDOVA001BB; Serial: TP:1203

Measurement SW: DASYS2, Version 52.10 (2); SEMCAD X Version 14.6.12 (7450)

A/Top worst position 3/Area Scan (61x61x1): Interpolated grid: dx=1.500 mm, dy=1.500 mm

Info: Interpolated medium parameters used for SAR evaluation.

Maximum value of SAR (interpolated) = 0.664 W/kg

A/Top worst position 3/Zoom Scan (7x7x7)/Cube 0: Measurement grid: dx=5mm, dy=5mm, dz=5mm

Reference Value = 20.48 V/m; Power Drift = -0.02 dB

Peak SAR (extrapolated) = 1.71 W/kg

SAR(1 g) = 0.370 W/kg; SAR(10 g) = 0.119 W/kg

Info: Interpolated medium parameters used for SAR evaluation.

Maximum value of SAR (measured) = 0.794 W/kg

Date: 2019/07/13

Ambient Temp. : 24.0 degree.C. Liquid Temp.; 23.5 degree.C.

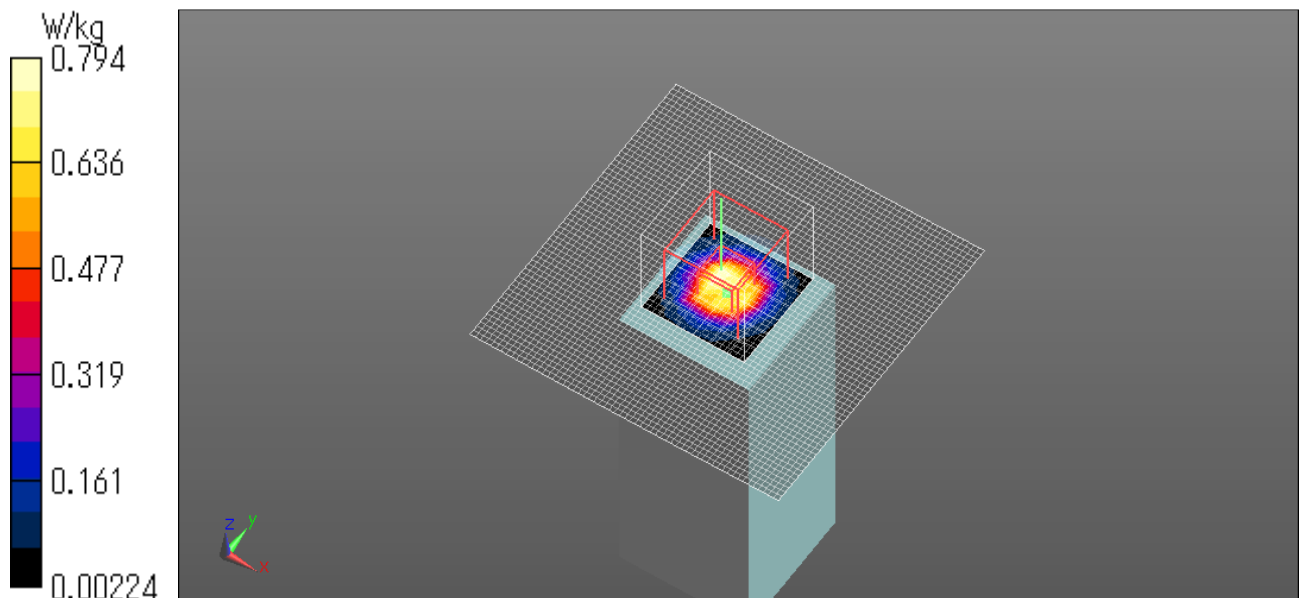

Plot No. 2

Radio Microphone Left 0mm 950.625MHz

Communication System: UID 0, Radio microphone (0); Communication System Band: UC; Frequency: 950.625 MHz; Duty Cycle: 1:1

Medium parameters used (interpolated): $f = 950.625$ MHz; $\sigma = 1.017$ S/m; $\epsilon_r = 39.98$; $\rho = 1000$ kg/m³

Phantom section: Flat Section

Measurement Standard: DASY5 (IEEE/IEC/ANSI C63.19-2007)

DASY5 Configuration

Probe: ES3DV3 - SN3335; ConvF(6.31, 6.31, 6.31) @ 950.625 MHz; Calibrated: 2018/07/26

Sensor-Surface: 3mm (Mechanical Surface Detection (Locations From Previous Scan Used)), Sensor-Surface: 3mm (Mechanical Surface Detection)

Electronics: DAE4 Sn1369; Calibrated: 2019/05/08

Phantom: ELI v5.0 (20deg probe tilt); Type: QDOVA001BB; Serial: TP:1203

Measurement SW: DASY52, Version 52.10 (2); SEMCAD X Version 14.6.12 (7450)

A/Left worst position/Area Scan (41x81x1): Interpolated grid: dx=1.500 mm, dy=1.500 mm

Info: Interpolated medium parameters used for SAR evaluation.

Maximum value of SAR (interpolated) = 0.119 W/kg

A/Left worst position/Zoom Scan (7x7x7)/Cube 0: Measurement grid: dx=5mm, dy=5mm, dz=5mm

Reference Value = 10.28 V/m; Power Drift = -0.06 dB

Peak SAR (extrapolated) = 0.194 W/kg

SAR(1 g) = 0.081 W/kg; SAR(10 g) = 0.042 W/kg

Info: Interpolated medium parameters used for SAR evaluation.

Maximum value of SAR (measured) = 0.106 W/kg

Date: 2019/07/12

Ambient Temp. : 24.0 degree.C. Liquid Temp.; 23.5 degree.C.

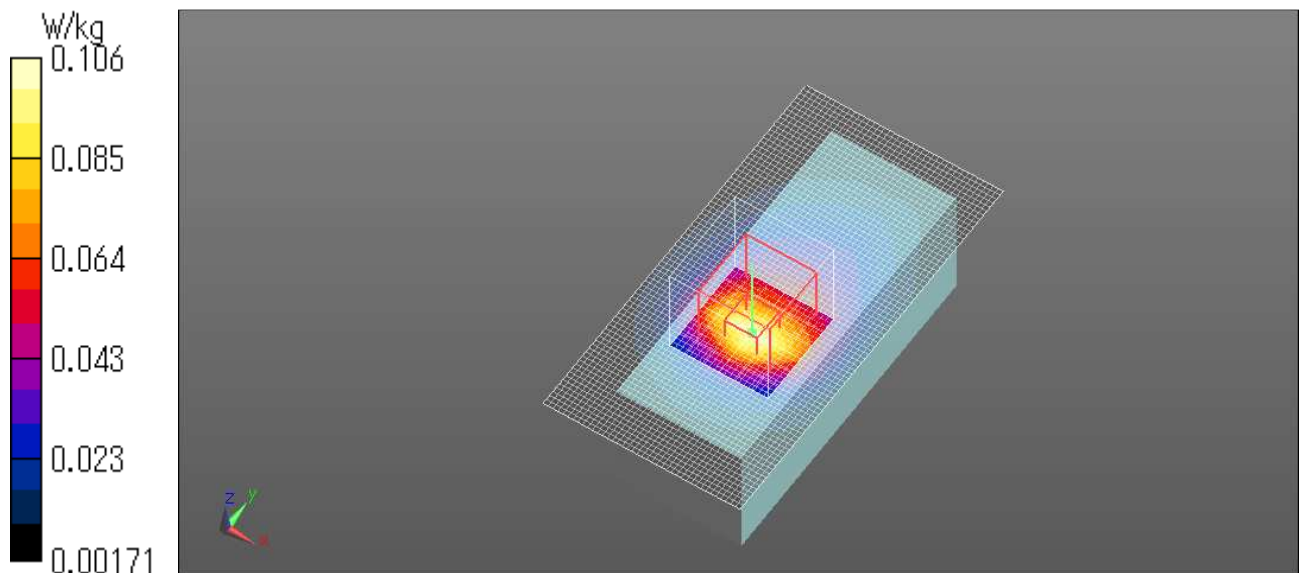

APPENDIX 3 : System specifications

Configuration and peripherals

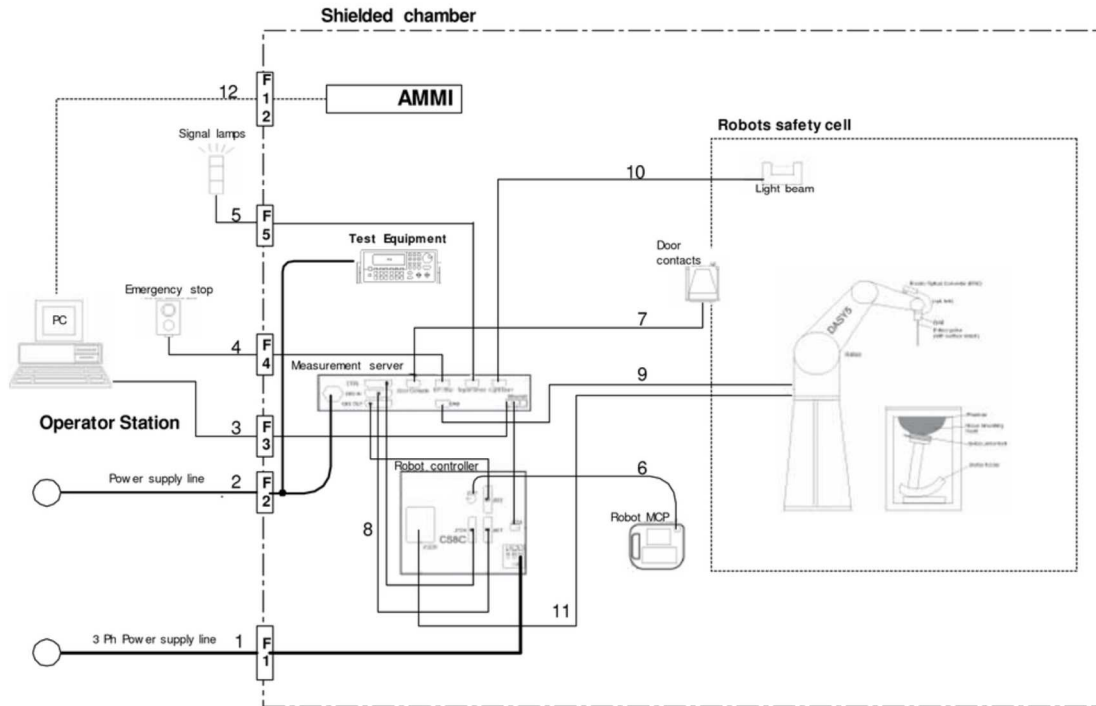

The DASYS5 system for performing compliance tests consist of the following items:

- a) A standard high precision 6-axis robot (Stäubli RX family) with controller and software.
An arm extension for accommodating the data acquisition electronics (DAE).
- b) An isotropic field probe optimized and calibrated for the targeted measurement.
- c) A data acquisition electronic (DAE), which performs the signal amplification, signal multiplexing, AD-conversion, offset measurements, mechanical surface detection, collision detection, etc. The unit is battery powered with standard or rechargeable batteries. The signal is optically transmitted to the EOC.
- d) The Electro-optical converter (EOC) performs the conversion between optical and electrical of the signals for the digital communication to the DAE and for the analog signal from the optical surface detection.
The EOC is connected to the measurement server.
- e) The function of the measurement server is to perform the time critical tasks such as signal filtering, control of the robot operation and fast movement interrupts.
- f) The Light Beam used is for probe alignment. This improves the (absolute) accuracy of the probe positioning.
- g) A computer running WinXP and the DASYS5 software.
- h) Remote control with teaches pendant and additional circuitry for robot safety such as warning lamps, etc.
- i) The phantom, the device holder and other accessories according to the targeted measurement.

Specifications

a) Robot TX60L

Number of Axes	:	6
Nominal Load	:	2 kg
Maximum Load	:	5kg
Reach	:	920mm
Repeatability	:	+/-0.03mm
Control Unit	:	CS8c
Programming Language	:	VAL3
Weight	:	52.2kg
Manufacture	:	Stäubli Robotics

b) E-Field Probe

Model	:	EX3DV4
Construction	:	Symmetrical design with triangular core Built-in shielding against static charges PEEK enclosure material (resistant to organic solvents, e.g., glycol ether)
Frequency	:	10 MHz to > 6 GHz Linearity: ± 0.2 dB (30 MHz to 6 GHz)
Directivity	:	+/-0.3 dB in HSL (rotation around probe axis) +/-0.5 dB in tissue material (rotation normal probe axis)
Dynamic Range	:	10uW/g to > 100 mW/g; Linearity +/-0.2 dB (noise: typically < 1uW/g)
Dimensions	:	Overall length: 337 mm (Tip: 20 mm) Tip diameter: 2.5mm (Body: 12 mm) Typical distance from probe tip to dipole centers: 1 mm
Application	:	Highprecision dosimetric measurement in any exposure scenario (e.g., very strong gradient fields). Only probe which enables compliance testing for frequencies up to 6GHz with precision of better 30%.
Manufacture	:	Schmid & Partner Engineering AG



EX3DV4 E-field Probe

Model	:	ES3DV3
Construction	:	Symmetric design with triangular core Interleaved sensors Built-in shielding against static charges PEEK enclosure material (resistant to organic solvents, e.g., DGBE) (resistant to organic solvents, e.g., glycol ether)
Frequency	:	10 MHz – 4 GHz; Linearity: ± 0.2 dB (30 MHz – 4 GHz)
Directivity	:	± 0.2 dB in TSL (rotation around probe axis) ± 0.3 dB in TSL (rotation normal to probe axis)
Dynamic Range	:	5 μ W/g – >100 mW/g; Linearity: ± 0.2 dB)
Dimensions	:	Overall length: 337 mm (tip: 20 mm) Tip diameter: 3.9 mm (body: 12 mm) Distance from probe tip to dipole centers: 2.0 mm
Application	:	General dosimetry up to 4 GHz Dosimetry in strong gradient fields Compliance tests of mobile phones
Manufacture	:	Schmid & Partner Engineering AG



ES3DV3 E-field Probe

c)Data Acquisition Electronic (DAE4)

Features	:	Signal amplifier, multiplexer, A/D converter and control logic Serial optical link for communication with DASY5 embedded system (fully remote controlled) Two step probe touch detector for mechanical surface detection and emergency robot stop
Measurement Range	:	-100 to +300 mV (16 bit resolution and two range settings: 4mV, 400mV)
Input Offset voltage	:	< 5 μ V (with auto zero)
Input Resistance	:	200 M Ω
Input Bias Current	:	< 50 fA
Battery Power	:	> 10 h of operation (with two 9.6 V NiMH accus)
Dimension	:	60 x 60 x 68 mm
Manufacture	:	Schmid & Partner Engineering AG

d)Electro-Optic Converter (EOC)

Version	:	EOC 61
Description	:	for TX60 robot arm, including proximity sensor
Manufacture	:	Schmid & Partner Engineering AG

e)DASY5 Measurement server

Features	:	Intel ULV Celeron 400MHz 128MB chip disk and 128MB RAM 16 Bit A/D converter for surface detection system Vacuum Fluorescent Display Robot Interface Serial link to DAE (with watchdog supervision) Door contact port (Possibility to connect a light curtain) Emergency stop port (to connect the remote control) Signal lamps port Light beam port Three Ethernet connection ports Two USB 2.0 Ports Two serial links Expansion port for future applications
Dimensions (L x W x H)	:	440 x 241 x 89 mm
Manufacture	:	Schmid & Partner Engineering AG

f) Light Beam Switches

Version	:	LB5
Dimensions (L x H)	:	110 x 80 mm
Thickness	:	12 mm
Beam-length	:	80 mm
Manufacture	:	Schmid & Partner Engineering AG

g)Software

Item	:	Dosimetric Assessment System DASY5
Type No.	:	SD 000 401A, SD 000 402A
Software version No.	:	DASY52, Version 52.6 (1)
Manufacture / Origin	:	Schmid & Partner Engineering AG

h)Robot Control Unit

Weight	:	70 Kg
AC Input Voltage	:	selectable
Manufacturer	:	Stäubli Robotics

i) Phantom and Device Holder

Phantom

Type	:	SAM Twin Phantom V4.0
Description	:	The shell corresponds to the specifications of the Specific Anthropomorphic Mannequin (SAM) phantom defined in IEEE 1528 and IEC 62209-1. It enables the dosimetric evaluation of left and right hand phone usage as well as body mounted usage at the flat phantom region. A cover prevents evaporation of the liquid. Reference markings on the phantom allow the complete setup of all predefined phantom positions and measurement grids by teaching three points with the robot.
Material	:	Vinylester, glass fiber reinforced (VE-GF)
Shell Material	:	Fiberglass
Thickness	:	2.0 +/-0.2 mm
Dimensions	:	Length: 1000 mm Width: 500 mm Height: adjustable feet
Volume	:	Approx. 25 liters
Manufacture	:	Schmid & Partner Engineering AG

Type	:	2mm Flat phantom ERI4.0
Description	:	Phantom for compliance testing of handheld and body-mounted wireless devices in the frequency range of 30 MHz to 6 GHz. ELI4 is fully compatible with the latest draft of the standard IEC 62209 Part II and all known tissue simulating liquids. ELI4 has been optimized regarding its performance and can be integrated into our standard phantom tables. A cover prevents evaporation of the liquid. Reference markings on the phantom allow installation of the complete setup, including all predefined phantom positions and measurement grids, by teaching three points. The phantom is supported by software version DAS4.5 and higher and is compatible with all SPEAG dosimetric probes and dipoles.
Material	:	Vinylester, glass fiber reinforced (VE-GF)
Shell Thickness	:	2.0 ± 0.2 mm (sagging: <1%)
Filling Volume	:	approx. 30 liters
Dimensions	:	Major ellipse axis: 600 mm Minor axis: 400 mm
Manufacture	:	Schmid & Partner Engineering AG

Device Holder

In combination with the Twin SAM Phantom V4.0/V4.0c or ELI4, the Mounting Device enables the rotation of the mounted transmitter device in spherical coordinates. Rotation point is the ear opening point. Transmitter devices can be easily and accurately positioned according to IEC, IEEE, FCC or other specifications. The device holder can be locked for positioning at different phantom sections (left head, right head, flat).

Material : POM

Laptio Extensions kit

Simple but effective and easy-to-use extension for Mounting Device that facilitates the testing of larger devices according to IEC 62209-2 (e.g., laptops, cameras, etc.). It is lightweight and fits easily on the upper part of the Mounting Device in place of the phone positioner. The extension is fully compatible with the Twin-SAM, ELI4 Phantoms.

Material : POM, Acrylic glass, Foam

Urethane

For this measurement, the urethane foam was used as device holder.

j) Simulated Tissues (Liquid)

The following tissue formulations are provided for reference only as some of the parameters have not been thoroughly verified. The composition of ingredients may be modified accordingly to achieve the desired target tissue parameters required for routine SAR evaluation.

Mixture (%)	Frequency (MHz)									
	450		900		1800		1950		2450	
Tissue Type	Head	Body	Head	Body	Head	Body	Head	Body	Head	Body
Water	38.91	46.21	40.29	50.75	55.24	70.17	55.41	69.79	55.0	68.64
Sugar	56.93	51.17	57.90	48.21	-	-	-	-	-	-
Cellulose	0.25	0.18	0.24	0.00	-	-	-	-	-	-
Salt (NaCl)	3.79	2.34	1.38	0.94	0.31	0.39	0.08	0.2	-	-
Preventol	0.12	0.08	0.18	0.10	-	-	-	-	-	-
DGMBE	-	-	-	-	44.45	29.44	44.51	30.0	45.0	31.37
Dielectric Constant	43.42	58.0	42.54	56.1	42.0	56.8	39.9	54.0	39.8	52.5
Conductivity (S/m)	0.85	0.83	0.91	0.95	1.0	1.07	1.42	1.45	1.88	1.78

Note: DGMBE (Diethylenglycol-monobutyl ether)

The simulated tissue (liquid) of 1800MHz was used for the test frequency of 1700MHz to 1800MHz.

Mixture (%)	Frequency (MHz)	
	650&750	1450
Tissue Type	Head and Body	Head and Body
Water	35-58%	52-75%
Sugar	40-60%	-
Cellulose	<0.3%	-
Salt (NaCl)	0-6%	<1%
Preventol	0.1-0.7%	-
DGMBE	-	25-48%

Mixture (%)	Frequency (MHz)	
	5800	
Tissue Type	Head	Body
Water	64.0	78.0
Mineral Oil	18.0	11.0
Emulsifiers	15.0	9.0
Additives and salt	3.0	2.0

Product identifier

Trade name	Broad Band Tissue Simulation Liquid HBBL600-10000V6, MBBL600-6000V6, HU16B, MU16B
Manufacturer/Supplier	Schmid & Partner Engineering AG

Declarable components:

CAS: 107-21-1 EINECS: 203-473-3 Reg.nr.: 01-2119456816-28-0000	Ethanediol STOT RE 2, H373; Acute Tox. 4, H302	< 5.2%
CAS: 68608-26-4 EINECS: 271-781-5 Reg.nr.: 01-2119527859-22-0000	Sodium petroleum sulfonate Eye Irrit. 2, H319	< 2.9%
CAS: 107-41-5 EINECS: 203-489-0 Reg.nr.: 01-2119539582-35-0000	Hexylene Glycol / 2-Methyl-pentane-2,4-diol Skin Irrit. 2, H315; Eye Irrit. 2, H319	< 2.9%
CAS: 68920-66-1 NLP: 500-236-9 Reg.nr.: 01-2119489407-26-0000	Alkoxylated alcohol, > C₁₆ Aquatic Chronic 2, H411; Skin Irrit. 2, H315; Eye Irrit. 2, H319	< 2.0%

UL Japan, Inc.

Ise EMC Lab.

4383-326 Asama-cho, Ise-shi, Mie-ken 516-0021 JAPAN

Telephone: +81 596 24 8999

Facsimile: +81 596 24 8124

System Check Dipole SAR Calibration Certificate -Dipole 450MHz(D450MHzV3,S/N:1051)

**Calibration Laboratory of
Schmid & Partner
Engineering AG**
Zeughausstrasse 43, 8004 Zurich, Switzerland



S Schweizerischer Kalibrierdienst
C Service suisse d'étalonnage
S Servizio svizzero di taratura
S Swiss Calibration Service

Accredited by the Swiss Accreditation Service (SAS)
The Swiss Accreditation Service is one of the signatories to the EA
Multilateral Agreement for the recognition of calibration certificates

Accreditation No.: SCS 0108

Client **UL Japan (Vitec)**

Certificate No: **D450V3-1051_Sep18**

CALIBRATION CERTIFICATE			
Object	D450V3 - SN:1051		
Calibration procedure(s)	QA CAL-15.v8 Calibration procedure for dipole validation kits below 700 MHz		
Calibration date:	September 10, 2018		
This calibration certificate documents the traceability to national standards, which realize the physical units of measurements (SI). The measurements and the uncertainties with confidence probability are given on the following pages and are part of the certificate.			
All calibrations have been conducted in the closed laboratory facility: environment temperature (22 ± 3)°C and humidity < 70%.			
Calibration Equipment used (M&TE critical for calibration)			
Primary Standards	ID #	Cal Date (Certificate No.)	Scheduled Calibration
Power meter NRP	SN: 104778	04-Apr-18 (No. 217-02672/02673)	Apr-19
Power sensor NRP-Z91	SN: 103244	04-Apr-18 (No. 217-02672)	Apr-19
Power sensor NRP-Z91	SN: 103245	04-Apr-18 (No. 217-02673)	Apr-19
Reference 20 dB Attenuator	SN: 5277 (20x)	04-Apr-18 (No. 217-02682)	Apr-19
Type-N mismatch combination	SN: 5047.2 / 06327	04-Apr-18 (No. 217-02683)	Apr-19
Reference Probe EX3DV4	SN: 3877	30-Dec-17 (No. EX3-3877_Dec17)	Dec-18
DAE4	SN: 654	05-Jul-18 (No. DAE4-654_Jul18)	Jul-19
Secondary Standards	ID #	Check Date (in house)	Scheduled Check
Power meter E4419B	SN: GB41293874	12-Jun-18 (No. 217-02285/02284)	In house check: Jun-20
Power sensor E4412A	SN: MY41498087	12-Jun-18 (No. 217-02285)	In house check: Jun-20
Power sensor E4412A	SN: 000110210	12-Jun-18 (No. 217-02284)	In house check: Jun-20
RF generator HP 8648C	SN: US3642U01700	04-Aug-99 (in house check Jun-18)	In house check: Jun-20
Network Analyzer Agilent E8358A	SN: US41080477	31-Mar-14 (in house check Oct-17)	In house check: Oct-18
Calibrated by:	Name Michael Weber	Function Laboratory Technician	Signature
Approved by:	Name Katja Pokovic	Function Technical Manager	Signature
			Issued: September 10, 2018
This calibration certificate shall not be reproduced except in full without written approval of the laboratory.			

Calibration Laboratory of
Schmid & Partner
Engineering AG
Zeughausstrasse 43, 8004 Zurich, Switzerland



S Schweizerischer Kalibrierdienst
C Service suisse d'étalonnage
S Servizio svizzero di taratura
S Swiss Calibration Service

Accredited by the Swiss Accreditation Service (SAS)
The Swiss Accreditation Service is one of the signatories to the EA
Multilateral Agreement for the recognition of calibration certificates

Accreditation No.: **SCS 0108**

Glossary:

TSL tissue simulating liquid
ConvF sensitivity in TSL / NORM x,y,z
N/A not applicable or not measured

Calibration is Performed According to the Following Standards:

- a) IEEE Std 1528-2013, "IEEE Recommended Practice for Determining the Peak Spatial-Averaged Specific Absorption Rate (SAR) in the Human Head from Wireless Communications Devices: Measurement Techniques", June 2013
- b) IEC 62209-1, "Measurement procedure for the assessment of Specific Absorption Rate (SAR) from hand-held and body-mounted devices used next to the ear (frequency range of 300 MHz to 6 GHz)", July 2016
- c) IEC 62209-2, "Procedure to determine the Specific Absorption Rate (SAR) for wireless communication devices used in close proximity to the human body (frequency range of 30 MHz to 6 GHz)", March 2010
- d) KDB 865664, "SAR Measurement Requirements for 100 MHz to 6 GHz"

Additional Documentation:

- e) DASY4/5 System Handbook

Methods Applied and Interpretation of Parameters:

- *Measurement Conditions:* Further details are available from the Validation Report at the end of the certificate. All figures stated in the certificate are valid at the frequency indicated.
- *Antenna Parameters with TSL:* The dipole is mounted with the spacer to position its feed point exactly below the center marking of the flat phantom section, with the arms oriented parallel to the body axis.
- *Feed Point Impedance and Return Loss:* These parameters are measured with the dipole positioned under the liquid filled phantom. The impedance stated is transformed from the measurement at the SMA connector to the feed point. The Return Loss ensures low reflected power. No uncertainty required.
- *Electrical Delay:* One-way delay between the SMA connector and the antenna feed point. No uncertainty required.
- *SAR measured:* SAR measured at the stated antenna input power.
- *SAR normalized:* SAR as measured, normalized to an input power of 1 W at the antenna connector.
- *SAR for nominal TSL parameters:* The measured TSL parameters are used to calculate the nominal SAR result.

The reported uncertainty of measurement is stated as the standard uncertainty of measurement multiplied by the coverage factor $k=2$, which for a normal distribution corresponds to a coverage probability of approximately 95%.

Measurement Conditions

DASY system configuration, as far as not given on page 1.

DASY Version	DASY5	V52.10.1
Extrapolation	Advanced Extrapolation	
Phantom	ELI4 Flat Phantom	Shell thickness: 2 ± 0.2 mm
Distance Dipole Center - TSL	15 mm	with Spacer
Zoom Scan Resolution	dx, dy, dz = 5 mm	
Frequency	450 MHz ± 1 MHz	

Head TSL parameters

The following parameters and calculations were applied.

	Temperature	Permittivity	Conductivity
Nominal Head TSL parameters	22.0 °C	43.5	0.87 mho/m
Measured Head TSL parameters	(22.0 ± 0.2) °C	44.4 ± 6 %	0.87 mho/m ± 6 %
Head TSL temperature change during test	< 0.5 °C	----	----

SAR result with Head TSL

SAR averaged over 1 cm ³ (1 g) of Head TSL	Condition	
SAR measured	250 mW input power	1.12 W/kg
SAR for nominal Head TSL parameters	normalized to 1W	4.50 W/kg ± 18.1 % (k=2)

SAR averaged over 10 cm ³ (10 g) of Head TSL	condition	
SAR measured	250 mW input power	0.749 W/kg
SAR for nominal Head TSL parameters	normalized to 1W	3.01 W/kg ± 17.6 % (k=2)

Body TSL parameters

The following parameters and calculations were applied.

	Temperature	Permittivity	Conductivity
Nominal Body TSL parameters	22.0 °C	56.7	0.94 mho/m
Measured Body TSL parameters	(22.0 ± 0.2) °C	56.2 ± 6 %	0.92 mho/m ± 6 %
Body TSL temperature change during test	< 0.5 °C	----	----

SAR result with Body TSL

SAR averaged over 1 cm ³ (1 g) of Body TSL	Condition	
SAR measured	250 mW input power	1.10 W/kg
SAR for nominal Body TSL parameters	normalized to 1W	4.47 W/kg ± 18.1 % (k=2)

SAR averaged over 10 cm ³ (10 g) of Body TSL	condition	
SAR measured	250 mW input power	0.737 W/kg
SAR for nominal Body TSL parameters	normalized to 1W	2.99 W/kg ± 17.6 % (k=2)

Appendix (Additional assessments outside the scope of SCS 0108)

Antenna Parameters with Head TSL

Impedance, transformed to feed point	58.6 Ω - 4.0 j Ω
Return Loss	- 21.2 dB

Antenna Parameters with Body TSL

Impedance, transformed to feed point	54.8 Ω - 7.9 j Ω
Return Loss	- 21.1 dB

General Antenna Parameters and Design

Electrical Delay (one direction)	1.349 ns
----------------------------------	----------

After long term use with 100W radiated power, only a slight warming of the dipole near the feedpoint can be measured.

The dipole is made of standard semirigid coaxial cable. The center conductor of the feeding line is directly connected to the second arm of the dipole. The antenna is therefore short-circuited for DC-signals. On some of the dipoles, small end caps are added to the dipole arms in order to improve matching when loaded according to the position as explained in the "Measurement Conditions" paragraph. The SAR data are not affected by this change. The overall dipole length is still according to the Standard.

No excessive force must be applied to the dipole arms, because they might bend or the soldered connections near the feedpoint may be damaged.

Additional EUT Data

Manufactured by	SPEAG
Manufactured on	July 29, 2005

DASY5 Validation Report for Head TSL

Date: 10.09.2018

Test Laboratory: SPEAG, Zurich, Switzerland

DUT: Dipole 450 MHz D450V3; Type: D450V3; Serial: D450V3 - SN:1051

Communication System: UID 0 - CW; Frequency: 450 MHz

Medium parameters used: $f = 450$ MHz; $\sigma = 0.87$ S/m; $\epsilon_r = 44.4$; $\rho = 1000$ kg/m³

Phantom section: Flat Section

Measurement Standard: DASY5 (IEEE/IEC/ANSI C63.19-2011)

DASY52 Configuration:

- Probe: EX3DV4 - SN3877; ConvF(10.5, 10.5, 10.5) @ 450 MHz; Calibrated: 30.12.2017
- Sensor-Surface: 1.4mm (Mechanical Surface Detection)
- Electronics: DAE4 Sn654; Calibrated: 05.07.2018
- Phantom: ELI v4.0; Type: QDOVA001BB; Serial: TP:1003
- DASY52 52.10.1(1476); SEMCAD X 14.6.11(7439)

Dipole Calibration for Head Tissue/d=15mm, Pin=250mW/Zoom Scan (7x7x7)/Cube 0:

Measurement grid: dx=5mm, dy=5mm, dz=5mm

Reference Value = 38.61 V/m; Power Drift = 0.01 dB

Peak SAR (extrapolated) = 1.73 W/kg

SAR(1 g) = 1.12 W/kg; SAR(10 g) = 0.749 W/kg

Maximum value of SAR (measured) = 1.51 W/kg

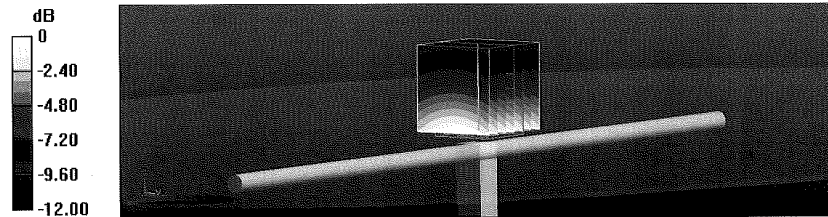

0 dB = 1.51 W/kg = 1.79 dBW/kg

Impedance Measurement Plot for Head TSL

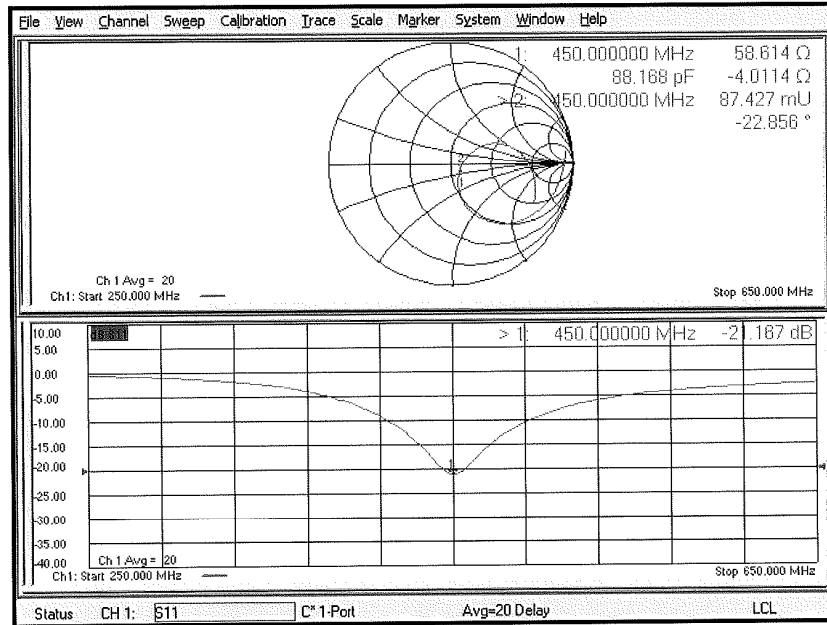

DASY5 Validation Report for Body TSL

Date: 10.09.2018

Test Laboratory: SPEAG, Zurich, Switzerland

DUT: Dipole 450 MHz D450V3; Type: D450V3; Serial: D450V3 - SN:1051

Communication System: UID 0 - CW; Frequency: 450 MHz

Medium parameters used: $f = 450$ MHz; $\sigma = 0.92$ S/m; $\epsilon_r = 56.2$; $\rho = 1000$ kg/m³

Phantom section: Flat Section

Measurement Standard: DASY5 (IEEE/IEC/ANSI C63.19-2011)

DASY52 Configuration:

- Probe: EX3DV4 - SN3877; ConvF(10.8, 10.8, 10.8) @ 450 MHz; Calibrated: 30.12.2017
- Sensor-Surface: 1.4mm (Mechanical Surface Detection)
- Electronics: DAE4 Sn654; Calibrated: 05.07.2018
- Phantom: ELI v4.0; Type: QDOVA001BB; Serial: TP:1003
- DASY52 52.10.1(1476); SEMCAD X 14.6.11(7439)

Dipole Calibration for Body Tissue/d=15mm, Pin=250mW/Zoom Scan (7x7x7)/Cube 0:

Measurement grid: dx=5mm, dy=5mm, dz=5mm

Reference Value = 41.30 V/m; Power Drift = -0.06 dB

Peak SAR (extrapolated) = 1.70 W/kg

SAR(1 g) = 1.1 W/kg; SAR(10 g) = 0.737 W/kg

Maximum value of SAR (measured) = 1.48 W/kg

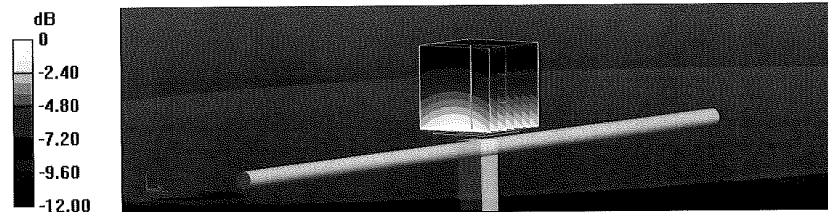

0 dB = 1.48 W/kg = 1.70 dBW/kg

Impedance Measurement Plot for Body TSL

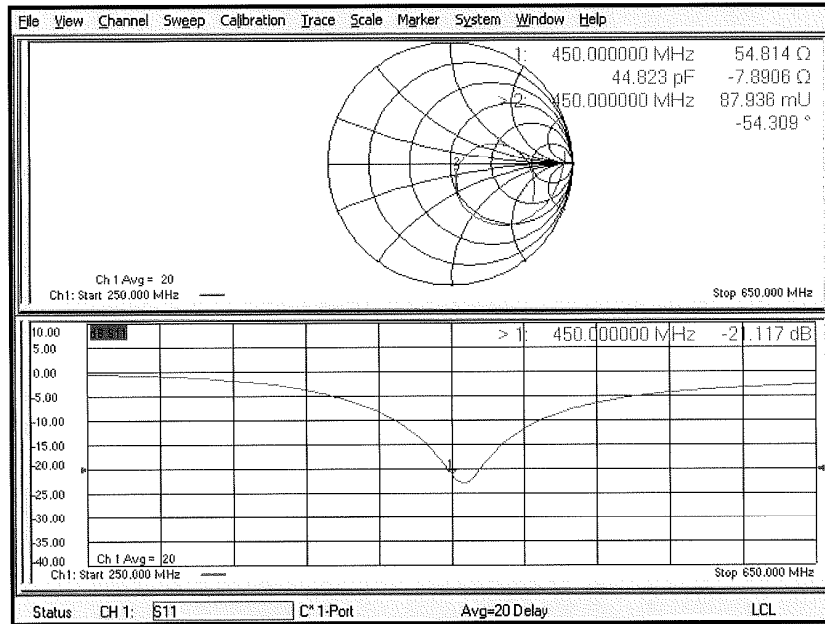

System Check Dipole SAR Calibration Certificate -Dipole 600MHz(D600V3,S/N:1003)

**Calibration Laboratory of
 Schmid & Partner
 Engineering AG**
 Zeughausstrasse 43, 8004 Zurich, Switzerland



S Schweizerischer Kalibrierdienst
C Service suisse d'étalonnage
S Servizio svizzero di taratura
S Swiss Calibration Service

Accredited by the Swiss Accreditation Service (SAS)
 The Swiss Accreditation Service is one of the signatories to the EA
 Multilateral Agreement for the recognition of calibration certificates

Accreditation No.: **SCS 0108**

Client **UL Japan (Vitec)**

Certificate No: **D600V3-1003_Sep16**

CALIBRATION CERTIFICATE			
Object	D600V3 - SN: 1003		
Calibration procedure(s)	QA CAL-15.v8 Calibration procedure for dipole validation kits below 700 MHz		
Calibration date:	September 19, 2016		
This calibration certificate documents the traceability to national standards, which realize the physical units of measurements (SI). The measurements and the uncertainties with confidence probability are given on the following pages and are part of the certificate.			
All calibrations have been conducted in the closed laboratory facility: environment temperature (22 ± 3)°C and humidity < 70%.			
Calibration Equipment used (M&TE critical for calibration)			
Primary Standards	ID #	Cal Date (Certificate No.)	Scheduled Calibration
Power meter NRP	SN: 104778	06-Apr-16 (No. 217-02288/02289)	Apr-17
Power sensor NRP-Z91	SN: 103244	06-Apr-16 (No. 217-02288)	Apr-17
Power sensor NRP-Z91	SN: 103245	06-Apr-16 (No. 217-02289)	Apr-17
Reference 20 dB Attenuator	SN: 5277 (20x)	05-Apr-16 (No. 217-02293)	Apr-17
Type-N mismatch combination	SN: 5047.2 / 06327	05-Apr-16 (No. 217-02295)	Apr-17
Reference Probe ET3DV6	SN: 1507	31-Dec-15 (No. ET3-1507_Dec15)	Dec-16
DAE4	SN: 654	12-Aug-16 (No. DAE4-654_Aug16)	Aug-17
Secondary Standards	ID #	Check Date (in house)	Scheduled Check
Power meter E4419B	SN: GB41293874	06-Apr-16 (No. 217-02285/02284)	In house check: Jun-18
Power sensor E4412A	SN: MY41498097	06-Apr-16 (No. 217-02285)	In house check: Jun-18
Power sensor E4412A	SN: 000110210	06-Apr-16 (No. 217-02284)	In house check: Jun-18
RF generator HP 8648C	SN: US3642U01700	04-Aug-99 (in house check Jun-16)	In house check: Jun-18
Network Analyzer HP 8753E	SN: US37390585	18-Oct-01 (in house check Oct-15)	In house check: Oct-16
Calibrated by:	Name Michael Weber	Function Laboratory Technician	Signature
Approved by:	Name Katja Pokovic	Function Technical Manager	Signature
			Issued: September 19, 2016
This calibration certificate shall not be reproduced except in full without written approval of the laboratory.			

Calibration Laboratory of
Schmid & Partner
Engineering AG
Zeughausstrasse 43, 8004 Zurich, Switzerland



S Schweizerischer Kalibrierdienst
C Service suisse d'étalonnage
S Servizio svizzero di taratura
S Swiss Calibration Service

Accredited by the Swiss Accreditation Service (SAS)
The Swiss Accreditation Service is one of the signatories to the EA
Multilateral Agreement for the recognition of calibration certificates

Accreditation No.: SCS 0108

Glossary:

TSL tissue simulating liquid
ConvF sensitivity in TSL / NORM x,y,z
N/A not applicable or not measured

Calibration is Performed According to the Following Standards:

- IEEE Std 1528-2013, "IEEE Recommended Practice for Determining the Peak Spatial-Averaged Specific Absorption Rate (SAR) in the Human Head from Wireless Communications Devices: Measurement Techniques", June 2013
- IEC 62209-1, "Procedure to measure the Specific Absorption Rate (SAR) for hand-held devices used in close proximity to the ear (frequency range of 300 MHz to 3 GHz)", February 2005
- IEC 62209-2, "Procedure to determine the Specific Absorption Rate (SAR) for wireless communication devices used in close proximity to the human body (frequency range of 30 MHz to 6 GHz)", March 2010
- KDB 865664, "SAR Measurement Requirements for 100 MHz to 6 GHz"

Additional Documentation:

- DASY4/5 System Handbook

Methods Applied and Interpretation of Parameters:

- Measurement Conditions:* Further details are available from the Validation Report at the end of the certificate. All figures stated in the certificate are valid at the frequency indicated.
- Antenna Parameters with TSL:* The dipole is mounted with the spacer to position its feed point exactly below the center marking of the flat phantom section, with the arms oriented parallel to the body axis.
- Feed Point Impedance and Return Loss:* These parameters are measured with the dipole positioned under the liquid filled phantom. The impedance stated is transformed from the measurement at the SMA connector to the feed point. The Return Loss ensures low reflected power. No uncertainty required.
- Electrical Delay:* One-way delay between the SMA connector and the antenna feed point. No uncertainty required.
- SAR measured:* SAR measured at the stated antenna input power.
- SAR normalized:* SAR as measured, normalized to an input power of 1 W at the antenna connector.
- SAR for nominal TSL parameters:* The measured TSL parameters are used to calculate the nominal SAR result.

The reported uncertainty of measurement is stated as the standard uncertainty of measurement multiplied by the coverage factor $k=2$, which for a normal distribution corresponds to a coverage probability of approximately 95%.

Measurement Conditions

DASY system configuration, as far as not given on page 1.

DASY Version	DASY5	V52.8.8
Extrapolation	Advanced Extrapolation	
Phantom	ELI4 Flat Phantom	Shell thickness: 2 ± 0.2 mm
Distance Dipole Center - TSL	15 mm	with Spacer
Zoom Scan Resolution	dx, dy, dz = 5 mm	
Frequency	600 MHz \pm 1 MHz	

Head TSL parameters

The following parameters and calculations were applied.

	Temperature	Permittivity	Conductivity
Nominal Head TSL parameters	22.0 °C	42.7	0.88 mho/m
Measured Head TSL parameters	(22.0 \pm 0.2) °C	41.5 \pm 6 %	0.87 mho/m \pm 6 %
Head TSL temperature change during test	< 0.5 °C	----	----

SAR result with Head TSL

SAR averaged over 1 cm ³ (1 g) of Head TSL	Condition	
SAR measured	250 mW input power	1.61 W/kg
SAR for nominal Head TSL parameters	normalized to 1W	6.46 W/kg \pm 18.1 % (k=2)

SAR averaged over 10 cm ³ (10 g) of Head TSL	condition	
SAR measured	250 mW input power	1.05 W/kg
SAR for nominal Head TSL parameters	normalized to 1W	4.21 W/kg \pm 17.6 % (k=2)

Body TSL parameters

The following parameters and calculations were applied.

	Temperature	Permittivity	Conductivity
Nominal Body TSL parameters	22.0 °C	56.1	0.95 mho/m
Measured Body TSL parameters	(22.0 \pm 0.2) °C	55.8 \pm 6 %	0.91 mho/m \pm 6 %
Body TSL temperature change during test	< 0.5 °C	----	----

SAR result with Body TSL

SAR averaged over 1 cm ³ (1 g) of Body TSL	Condition	
SAR measured	250 mW input power	1.62 W/kg
SAR for nominal Body TSL parameters	normalized to 1W	6.69 W/kg \pm 18.1 % (k=2)

SAR averaged over 10 cm ³ (10 g) of Body TSL	condition	
SAR measured	250 mW input power	1.07 W/kg
SAR for nominal Body TSL parameters	normalized to 1W	4.40 W/kg \pm 17.6 % (k=2)

Appendix (Additional assessments outside the scope of SCS 0108)

Antenna Parameters with Head TSL

Impedance, transformed to feed point	60.2 Ω + 2.3 $\mu\Omega$
Return Loss	- 20.5 dB

Antenna Parameters with Body TSL

Impedance, transformed to feed point	53.0 Ω - 4.8 $\mu\Omega$
Return Loss	- 25.2 dB

General Antenna Parameters and Design

Electrical Delay (one direction)	1.153 ns
----------------------------------	----------

After long term use with 100W radiated power, only a slight warming of the dipole near the feedpoint can be measured.

The dipole is made of standard semirigid coaxial cable. The center conductor of the feeding line is directly connected to the second arm of the dipole. The antenna is therefore short-circuited for DC-signals. On some of the dipoles, small end caps are added to the dipole arms in order to improve matching when loaded according to the position as explained in the "Measurement Conditions" paragraph. The SAR data are not affected by this change. The overall dipole length is still according to the Standard.

No excessive force must be applied to the dipole arms, because they might bend or the soldered connections near the feedpoint may be damaged.

Additional EUT Data

Manufactured by	SPEAG
Manufactured on	February 08, 2013

DASY5 Validation Report for Head TSL

Date: 19.09.2016

Test Laboratory: SPEAG, Zurich, Switzerland

DUT: Dipole 600 MHz; Type: D600V3; Serial: D600V3 - SN: 1003

Communication System: UID 0 - CW; Frequency: 600 MHz
Medium parameters used: $f = 600$ MHz; $\sigma = 0.87$ S/m; $\epsilon_r = 41.5$; $\rho = 1000$ kg/m³
Phantom section: Flat Section
Measurement Standard: DASY5 (IEEE/IEC/ANSI C63.19-2011)

DASY52 Configuration:

- Probe: ET3DV6 - SN1507; ConvF(6.54, 6.54, 6.54); Calibrated: 31.12.2015;
- Sensor-Surface: 4mm (Mechanical Surface Detection)
- Electronics: DAE4 Sn654; Calibrated: 12.08.2016
- Phantom: ELI v4.0; Type: QDOVA001BB; Serial: TP:1003
- DASY52 52.8.8(1258); SEMCAD X 14.6.10(7372)

Dipole Calibration for Head Tissue/Pin=250 mW, d=15mm/Zoom Scan (7x7x7)/Cube 0:

Measurement grid: dx=5mm, dy=5mm, dz=5mm
Reference Value = 45.72 V/m; Power Drift = -0.00 dB
Peak SAR (extrapolated) = 2.57 W/kg
SAR(1 g) = 1.61 W/kg; SAR(10 g) = 1.05 W/kg
Maximum value of SAR (measured) = 1.72 W/kg

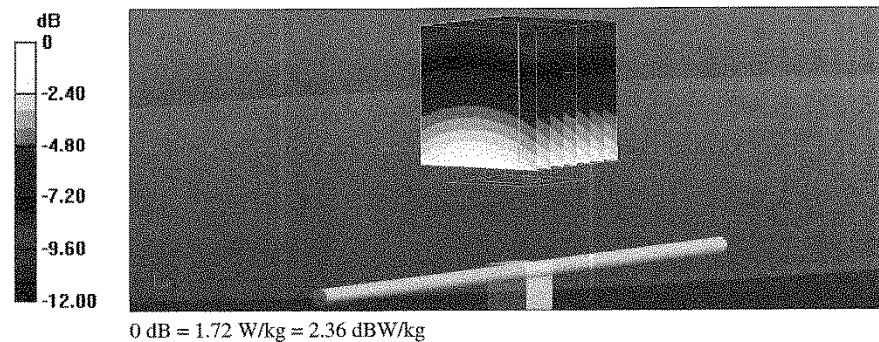

Impedance Measurement Plot for Head TSL

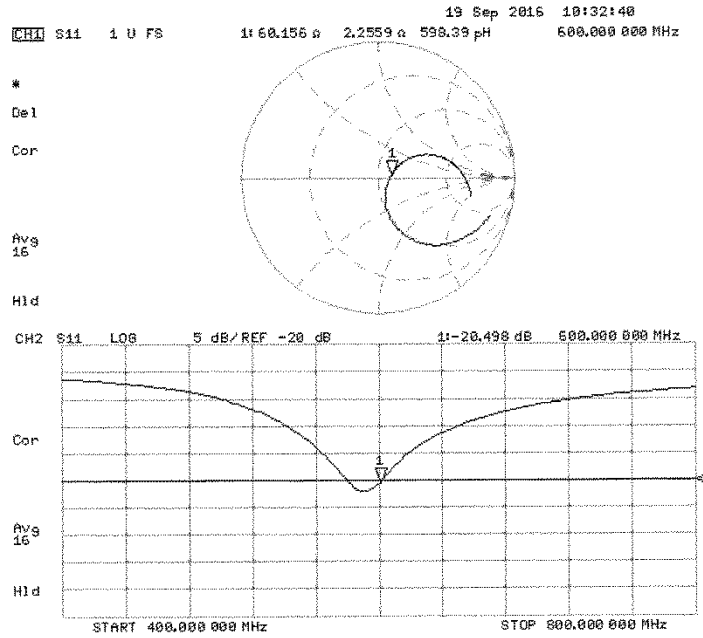

DASY5 Validation Report for Body TSL

Date: 19.09.2016

Test Laboratory: SPEAG, Zurich, Switzerland

DUT: Dipole 600 MHz; Type: D600V3; Serial: D600V3 - SN: 1003

Communication System: UID 0 - CW; Frequency: 600 MHz

Medium parameters used: $f = 600$ MHz; $\sigma = 0.91$ S/m; $\epsilon_r = 55.8$; $\rho = 1000$ kg/m³

Phantom section: Flat Section

Measurement Standard: DASY5 (IEEE/IEC/ANSI C63.19-2011)

DASY52 Configuration:

- Probe: ET3DV6 - SN1507; ConvF(6.5, 6.5, 6.5); Calibrated: 31.12.2015;
- Sensor-Surface: 4mm (Mechanical Surface Detection)
- Electronics: DAE4 Sn654; Calibrated: 12.08.2016
- Phantom: ELI v4.0; Type: QDOVA001BB; Serial: TP:1003
- DASY52 52.8.8(1258); SEMCAD X 14.6.10(7372)

Dipole Calibration for Body Tissue/Pin=250 mW, d=15mm/Zoom Scan (7x7x7)/Cube 0:

Measurement grid: dx=5mm, dy=5mm, dz=5mm

Reference Value = 44.64 V/m; Power Drift = -0.00 dB

Peak SAR (extrapolated) = 2.58 W/kg

SAR(1 g) = 1.62 W/kg; SAR(10 g) = 1.07 W/kg

Maximum value of SAR (measured) = 1.74 W/kg

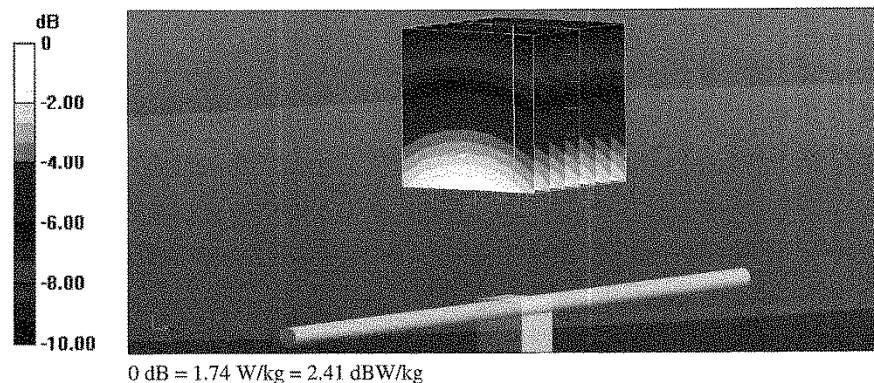

Impedance Measurement Plot for Body TSL

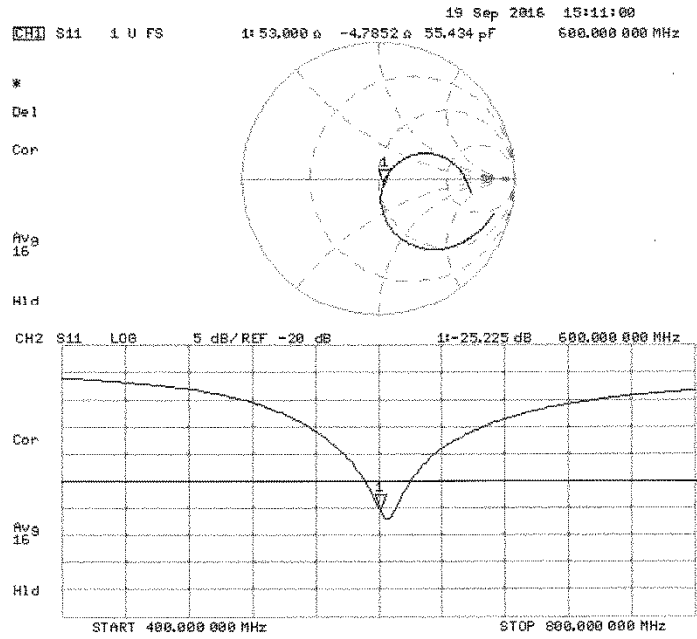

D600V3 Calibration for Impedance and Return-loss

Equipment	Dipole Antenna	Model	D600V3
Manufacture	Schmid&Partner Engineering AG	Serial	1003
Tested by	Tomohisa Nakagawa		

1. Test environment

Date	September13, 2017		
Ambient Temperature	23.0 deg.C	Relative humidity	68%RH
Date	September10, 2018		
Ambient Temperature	24.0 deg.C	Relative humidity	56%RH

2. Equipment used

Calibration at September, 2017

Control No.	Instrument	Manufacturer	Model No	Serial No	Test Item	Calibration Date * Interval(month)
MOS-37	Digital thermometer	LKM electronic	DTM3000	-	SAR	2017/07/26 * 12
MPF-03	2mm Oval Flat Phantom	Schmid&Partner Engineering AG	QDOVA001BB	1203	SAR	2017/05/29 * 12
MMSL0650	Tissue simulation liquid (Body)	Schmid&Partner Engineering AG	MSL650	20090914		Pre Check
MHSL0650	Tissue simulation liquid (Head)	Schmid&Partner Engineering AG	HSL650	20090911		Pre Check
EST-63	Network Analyzer	KEYSIGHT	E5071C	MY46523746	SAR	2017/02/03 * 12
EST-64	Calibration Kit	KEYSIGHT	85032F	MY53200995	SAR	2017/02/02 * 12
MDA-21	Dipole Antenna	Schmid&Partner Engineering AG	D600V3	1003	SAR	2016/09/19 * 12

Calibration at September, 2018

Control No.	Instrument	Manufacturer	Model No	Serial No	Test Item	Calibration Date * Interval(month)
MOS-37	Digital thermometer	LKM electronic	DTM3000	-	SAR	2018/07/30 * 12
MPF-03	2mm Oval Flat Phantom	Schmid&Partner Engineering AG	QDOVA001BB	1203	SAR	2018/05/08 * 12
MMSL0650	Tissue simulation liquid (Body)	Schmid&Partner Engineering AG	MSL650	20090914		Pre Check
MHSL0650	Tissue simulation liquid (Head)	Schmid&Partner Engineering AG	HSL650	20090911		Pre Check
EST-63	Network Analyzer	KEYSIGHT	E5071C	MY46523746	SAR	2018/04/30 * 12
EST-64	Calibration Kit	KEYSIGHT	85032F	MY53200995	SAR	2018/04/23 * 12
MDA-21	Dipole Antenna	Schmid&Partner Engineering AG	D600V3	1003	SAR	2016/09/19 * 24

UL Japan, Inc.

Ise EMC Lab.

4383-326 Asama-cho, Ise-shi, Mie-ken 516-0021 JAPAN

Telephone: +81 596 24 8999

Facsimile: +81 596 24 8124

3. Test Result

Impedance,Transformed to feed point	cal day	Head (real part) [Ω]	Head (img part) [jΩ]	Deviation (real part) [Ω]	Deviation (img part) [jΩ]	Tolerance	Result
Calibration (SPEAG)	2016/9/19	60.20	2.30	-	-	-	-
Calibration(ULJ)	2017/9/13	61.12	-1.06	0.92	-3.36	+/-5Ω+/-5jΩ	Complied
Calibration(ULJ)	2018/9/10	59.94	-2.63	-1.18	-1.57	+/-5Ω+/-5jΩ	Complied

Return loss	cal day	Head [dB]	Deviation [dB]	Tolerance [+/-dB]	Result
Calibration (SPEAG)	2016/9/19	-20.50	-	-	-
Calibration(ULJ)	2017/9/13	-22.75	-2.25	4.10	Complied
Calibration(ULJ)	2018/9/10	-24.25	-3.75	4.55	Complied

Impedance,Transformed to feed point	cal day	Body (real part) [Ω]	Body (img part) [jΩ]	Deviation (real part) [Ω]	Deviation (img part) [jΩ]	Tolerance	Result
Calibration (SPEAG)	2016/9/19	53.00	-4.80	-	-	-	-
Calibration(ULJ)	2017/9/13	56.19	-5.78	3.19	-0.98	+/-5Ω+/-5jΩ	Complied
Calibration(ULJ)	2018/9/10	55.05	-5.45	-1.14	0.33	+/-5Ω+/-5jΩ	Complied

Return loss	cal day	Body [dB]	Deviation [dB]	Tolerance [+/-dB]	Result
Calibration (SPEAG)	2016/9/19	-25.20	-	-	-
Calibration(ULJ)	2017/9/13	-22.67	2.54	5.04	Complied
Calibration(ULJ)	2018/9/10	-25.29	-2.63	4.533	Complied

*Tolerance : According to the KDB865664D01

Measurement Plots

<Head Liquid> 2017

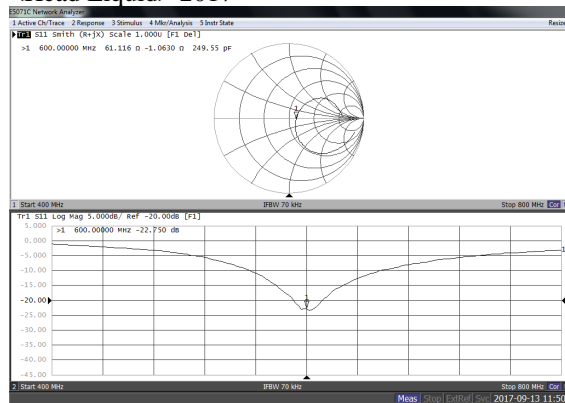

<Head Liquid> 2018

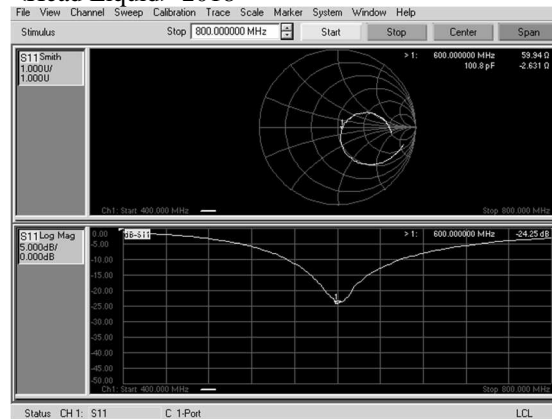

<Body Liquid> 2017

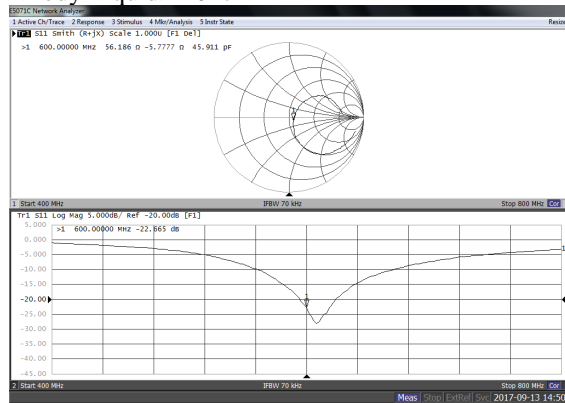

<Body Liquid> 2018

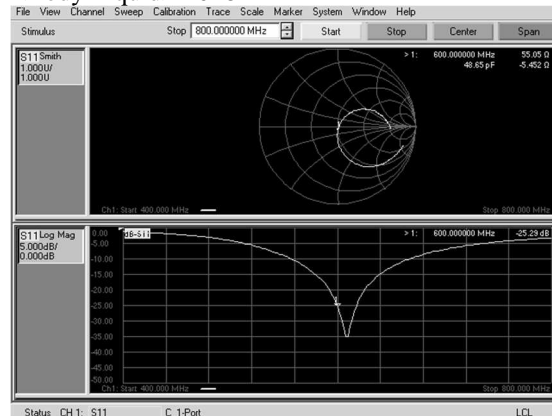

System Check Dipole SAR Calibration Certificate -Dipole 900MHz (D900V2 S/N: 1d168)

**Calibration Laboratory of
 Schmid & Partner
 Engineering AG**
 Zeughausstrasse 43, 8004 Zurich, Switzerland



*Checked
 M. Nage 05/10/2018*

S Schweizerischer Kalibrierdienst
C Service suisse d'étalonnage
S Servizio svizzero di taratura
S Swiss Calibration Service

Accredited by the Swiss Accreditation Service (SAS)
 The Swiss Accreditation Service is one of the signatories to the EA
 Multilateral Agreement for the recognition of calibration certificates

Accreditation No.: **SCS 0108**

Client **UL RFI UK**

Certificate No: **D900V2-1d168_Sep18**

CALIBRATION CERTIFICATE			
Object	D900V2 - SN:1d168		
Calibration procedure(s)	QA CAL-05.v10 Calibration procedure for dipole validation kits above 700 MHz		
Calibration date:	September 18, 2018		
This calibration certificate documents the traceability to national standards, which realize the physical units of measurements (SI). The measurements and the uncertainties with confidence probability are given on the following pages and are part of the certificate.			
All calibrations have been conducted in the closed laboratory facility: environment temperature (22 ± 3)°C and humidity < 70%.			
Calibration Equipment used (M&TE critical for calibration)			
Primary Standards	ID #	Cal Date (Certificate No.)	Scheduled Calibration
Power meter NRP	SN: 104778	04-Apr-18 (No. 217-02672/02673)	Apr-19
Power sensor NRP-Z91	SN: 103244	04-Apr-18 (No. 217-02672)	Apr-19
Power sensor NRP-Z91	SN: 103245	04-Apr-18 (No. 217-02673)	Apr-19
Reference 20 dB Attenuator	SN: 5058 (20k)	04-Apr-18 (No. 217-02682)	Apr-19
Type-N mismatch combination	SN: 5047.2 / 06327	04-Apr-18 (No. 217-02683)	Apr-19
Reference Probe EX3DV4	SN: 7349	30-Dec-17 (No. EX3-7349_Dec17)	Dec-18
DAE4	SN: 601	26-Oct-17 (No. DAE4-601_Oct17)	Oct-18
Secondary Standards	ID #	Check Date (in house)	Scheduled Check
Power meter EPM-442A	SN: GB37480704	07-Oct-15 (in house check Oct-16)	In house check: Oct-18
Power sensor HP 8481A	SN: US37292783	07-Oct-15 (in house check Oct-16)	In house check: Oct-18
Power sensor HP 8481A	SN: MY41092317	07-Oct-15 (in house check Oct-16)	In house check: Oct-18
RF generator R&S SMT-06	SN: 100972	15-Jun-15 (in house check Oct-16)	In house check: Oct-18
Network Analyzer Agilent E8358A	SN: US41080477	31-Mar-14 (in house check Oct-17)	In house check: Oct-18
Calibrated by:	Name Jeton Kastrati	Function Laboratory Technician	Signature
Approved by:	Name Katja Pokovic	Technical Manager	
This calibration certificate shall not be reproduced except in full without written approval of the laboratory.			Issued: September 19, 2018

**Calibration Laboratory of
Schmid & Partner
Engineering AG**
Zeughausstrasse 43, 8004 Zurich, Switzerland



S Schweizerischer Kalibrierdienst
C Service suisse d'étalonnage
S Servizio svizzero di taratura
S Swiss Calibration Service

Accredited by the Swiss Accreditation Service (SAS)
The Swiss Accreditation Service is one of the signatories to the EA
Multilateral Agreement for the recognition of calibration certificates

Accreditation No.: SCS 0108

Glossary:

TSL tissue simulating liquid
ConvF sensitivity in TSL / NORM x,y,z
N/A not applicable or not measured

Calibration is Performed According to the Following Standards:

- IEEE Std 1528-2013, "IEEE Recommended Practice for Determining the Peak Spatial-Averaged Specific Absorption Rate (SAR) in the Human Head from Wireless Communications Devices: Measurement Techniques", June 2013
- IEC 62209-1, "Measurement procedure for the assessment of Specific Absorption Rate (SAR) from hand-held and body-mounted devices used next to the ear (frequency range of 300 MHz to 6 GHz)", July 2016
- IEC 62209-2, "Procedure to determine the Specific Absorption Rate (SAR) for wireless communication devices used in close proximity to the human body (frequency range of 30 MHz to 6 GHz)", March 2010
- KDB 865664, "SAR Measurement Requirements for 100 MHz to 6 GHz"

Additional Documentation:

- DASY4/5 System Handbook

Methods Applied and Interpretation of Parameters:

- Measurement Conditions:* Further details are available from the Validation Report at the end of the certificate. All figures stated in the certificate are valid at the frequency indicated.
- Antenna Parameters with TSL:* The dipole is mounted with the spacer to position its feed point exactly below the center marking of the flat phantom section, with the arms oriented parallel to the body axis.
- Feed Point Impedance and Return Loss:* These parameters are measured with the dipole positioned under the liquid filled phantom. The impedance stated is transformed from the measurement at the SMA connector to the feed point. The Return Loss ensures low reflected power. No uncertainty required.
- Electrical Delay:* One-way delay between the SMA connector and the antenna feed point. No uncertainty required.
- SAR measured:* SAR measured at the stated antenna input power.
- SAR normalized:* SAR as measured, normalized to an input power of 1 W at the antenna connector.
- SAR for nominal TSL parameters:* The measured TSL parameters are used to calculate the nominal SAR result.

The reported uncertainty of measurement is stated as the standard uncertainty of measurement multiplied by the coverage factor $k=2$, which for a normal distribution corresponds to a coverage probability of approximately 95%.

Measurement Conditions

DASY system configuration, as far as not given on page 1.

DASY Version	DASY5	V52.10.1
Extrapolation	Advanced Extrapolation	
Phantom	Modular Flat Phantom	
Distance Dipole Center - TSL	15 mm	with Spacer
Zoom Scan Resolution	dx, dy, dz = 5 mm	
Frequency	900 MHz ± 1 MHz	

Head TSL parameters

The following parameters and calculations were applied.

	Temperature	Permittivity	Conductivity
Nominal Head TSL parameters	22.0 °C	41.5	0.97 mho/m
Measured Head TSL parameters	(22.0 ± 0.2) °C	40.6 ± 6 %	0.94 mho/m ± 6 %
Head TSL temperature change during test	< 0.5 °C	----	----

SAR result with Head TSL

SAR averaged over 1 cm ³ (1 g) of Head TSL	Condition	
SAR measured	250 mW input power	2.63 W/kg
SAR for nominal Head TSL parameters	normalized to 1W	10.7 W/kg ± 17.0 % (k=2)

SAR averaged over 10 cm ³ (10 g) of Head TSL	condition	
SAR measured	250 mW input power	1.68 W/kg
SAR for nominal Head TSL parameters	normalized to 1W	6.82 W/kg ± 16.5 % (k=2)

Body TSL parameters

The following parameters and calculations were applied.

	Temperature	Permittivity	Conductivity
Nominal Body TSL parameters	22.0 °C	55.0	1.05 mho/m
Measured Body TSL parameters	(22.0 ± 0.2) °C	55.3 ± 6 %	1.02 mho/m ± 6 %
Body TSL temperature change during test	< 0.5 °C	----	----

SAR result with Body TSL

SAR averaged over 1 cm ³ (1 g) of Body TSL	Condition	
SAR measured	250 mW input power	2.68 W/kg
SAR for nominal Body TSL parameters	normalized to 1W	11.0 W/kg ± 17.0 % (k=2)

SAR averaged over 10 cm ³ (10 g) of Body TSL	condition	
SAR measured	250 mW input power	1.74 W/kg
SAR for nominal Body TSL parameters	normalized to 1W	7.09 W/kg ± 16.5 % (k=2)

Appendix (Additional assessments outside the scope of SCS 0108)

Antenna Parameters with Head TSL

Impedance, transformed to feed point	50.7 Ω - 1.3 j Ω
Return Loss	- 36.7 dB

Antenna Parameters with Body TSL

Impedance, transformed to feed point	45.5 Ω - 3.1 j Ω
Return Loss	- 24.9 dB

General Antenna Parameters and Design

Electrical Delay (one direction)	1.403 ns
----------------------------------	----------

After long term use with 100W radiated power, only a slight warming of the dipole near the feedpoint can be measured.

The dipole is made of standard semirigid coaxial cable. The center conductor of the feeding line is directly connected to the second arm of the dipole. The antenna is therefore short-circuited for DC-signals. On some of the dipoles, small end caps are added to the dipole arms in order to improve matching when loaded according to the position as explained in the "Measurement Conditions" paragraph. The SAR data are not affected by this change. The overall dipole length is still according to the Standard.

No excessive force must be applied to the dipole arms, because they might bend or the soldered connections near the feedpoint may be damaged.

Additional EUT Data

Manufactured by	SPEAG
Manufactured on	March 27, 2013

DASY5 Validation Report for Head TSL

Date: 18.09.2018

Test Laboratory: SPEAG, Zurich, Switzerland

DUT: Dipole 900 MHz; Type: D900V2; Serial: D900V2 - SN:1d168

Communication System: UID 0 - CW; Frequency: 900 MHz

Medium parameters used: $f = 900$ MHz; $\sigma = 0.94$ S/m; $\epsilon_r = 40.6$; $\rho = 1000$ kg/m³

Phantom section: Flat Section

Measurement Standard: DASY5 (IEEE/IEC/ANSI C63.19-2011)

DASY52 Configuration:

- Probe: EX3DV4 - SN7349; ConvF(9.71, 9.71, 9.71) @ 900 MHz; Calibrated: 30.12.2017
- Sensor-Surface: 1.4mm (Mechanical Surface Detection)
- Electronics: DAE4 Sn601; Calibrated: 26.10.2017
- Phantom: Flat Phantom 4.9 (front); Type: QD 00L P49 AA; Serial: 1001
- DASY52 52.10.1(1476); SEMCAD X 14.6.11(7439)

Dipole Calibration for Head Tissue/Pin=250 mW, d=15mm/Zoom Scan (7x7x7)/Cube 0:

Measurement grid: dx=5mm, dy=5mm, dz=5mm

Reference Value = 65.39 V/m; Power Drift = -0.04 dB

Peak SAR (extrapolated) = 4.05 W/kg

SAR(1 g) = 2.63 W/kg; SAR(10 g) = 1.68 W/kg

Maximum value of SAR (measured) = 3.56 W/kg

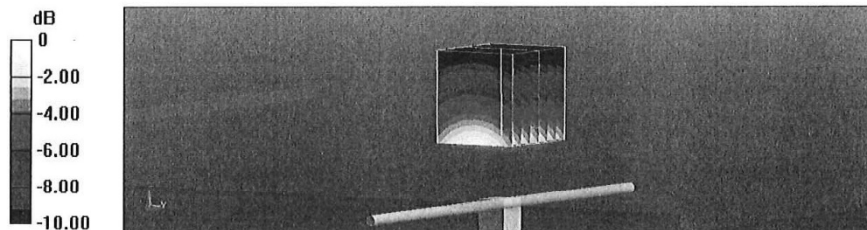

0 dB = 3.56 W/kg = 5.51 dBW/kg

Impedance Measurement Plot for Head TSL

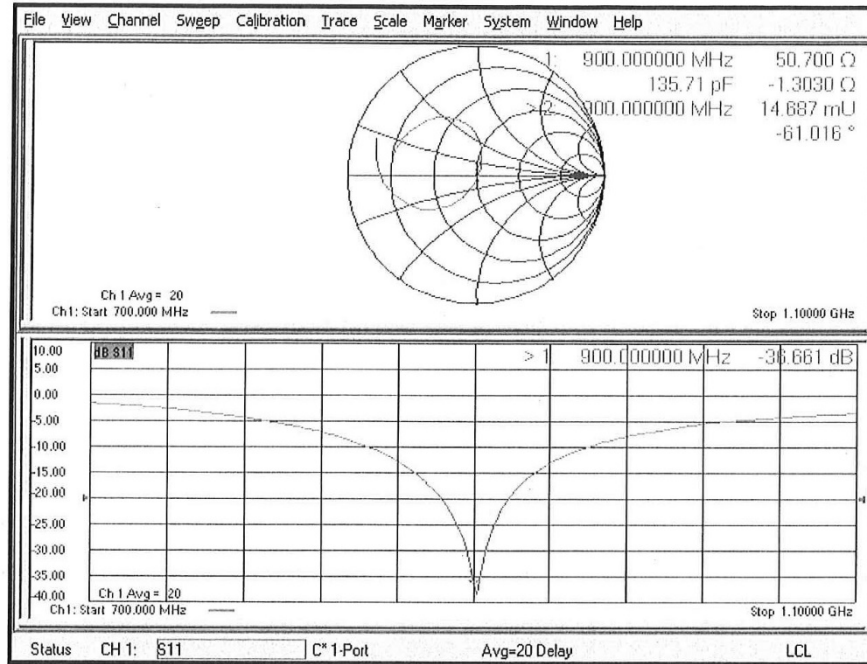

DASY5 Validation Report for Body TSL

Date: 18.09.2018

Test Laboratory: SPEAG, Zurich, Switzerland

DUT: Dipole 900 MHz; Type: D900V2; Serial: D900V2 - SN:1d168

Communication System: UID 0 - CW; Frequency: 900 MHz

Medium parameters used: $f = 900$ MHz; $\sigma = 1.02$ S/m; $\epsilon_r = 55.3$; $\rho = 1000$ kg/m³

Phantom section: Flat Section

Measurement Standard: DASY5 (IEE/IEC/ANSI C63.19-2011)

DASY52 Configuration:

- Probe: EX3DV4 - SN7349; ConvF(9.83, 9.83, 9.83) @ 900 MHz; Calibrated: 30.12.2017
- Sensor-Surface: 1.4mm (Mechanical Surface Detection)
- Electronics: DAE4 Sn601; Calibrated: 26.10.2017
- Phantom: Flat Phantom 4.9 (Back); Type: QD 00R P49 AA; Serial: 1005
- DASY52 52.10.1(1476); SEMCAD X 14.6.11(7439)

Dipole Calibration for Body Tissue/Pin=250 mW, d=15mm/Zoom Scan (7x7x7)/Cube 0:

Measurement grid: dx=5mm, dy=5mm, dz=5mm

Reference Value = 63.32 V/m; Power Drift = -0.04 dB

Peak SAR (extrapolated) = 3.95 W/kg

SAR(1 g) = 2.68 W/kg; SAR(10 g) = 1.74 W/kg

Maximum value of SAR (measured) = 3.54 W/kg

