



RADIO TEST REPORT

Test Report No. : 13554183S-F

Applicant : Sony Corporation, Japan and Sony Group Companies
Type of EUT : CONTROL BOX
Model Number of EUT : TMR-A9WT (Module: WM-BAC-AT-49)
FCC ID : AK8TMRA9WT
Test regulation : FCC Part 15 Subpart E: 2021
(for DFS test)
*Slave
Test result : Complied (Refer to SECTION 3.2)

1. This test report shall not be reproduced in full or partial, without the written approval of UL Japan, Inc.
2. The results in this report apply only to the sample tested.
3. This sample tested is in compliance with the limits of the above regulation.
4. The test results in this test report are traceable to the national or international standards.
5. This test report must not be used by the customer to claim product certification, approval, or endorsement by the A2LA accreditation body.
6. This test report covers Radio technical requirements.
It does not cover administrative issues such as Manual or non-Radio test related Requirements. (if applicable)
7. The all test items in this test report are conducted by UL Japan, Inc. Shonan EMC Lab.
8. The opinions and the interpretations to the result of the description in this report are outside scopes where UL Japan has been accredited.
9. The information provided from the customer for this report is identified in SECTION 1.

Date of test: November 13, 2020

Representative test engineer: K. Adachi
Kenichi Adachi
Engineer
Consumer Technology Division

Approved by: T. Imamura
Toyokazu Imamura
Leader
Consumer Technology Division



CERTIFICATE 1266.03

- The testing in which "Non-accreditation" is displayed is outside the accreditation scopes in UL Japan.
 There is no testing item of "Non-accreditation".

UL Japan, Inc.
Shonan EMC Lab.

1-22-3 Megumigaoka, Hiratsuka-shi, Kanagawa-ken, 259-1220, JAPAN
Telephone : +81 463 50 6400
Facsimile : +81 463 50 6401

REVISION HISTORY

Original Test Report No.: 13554183S-F

Revision	Test report No.	Date	Page revised	Contents
- (Original)	13554183S-F	February 26, 2021	-	-

UL Japan, Inc.
Shonan EMC Lab.

1-22-3 Megumigaoka, Hiratsuka-shi, Kanagawa-ken, 259-1220 JAPAN
Telephone : +81 463 50 6400
Facsimile : +81 463 50 6401

Reference: Abbreviations (Including words undescribed in this report)

A2LA	The American Association for Laboratory Accreditation	MCS	Modulation and Coding Scheme
AC	Alternating Current	MRA	Mutual Recognition Arrangement
AFH	Adaptive Frequency Hopping	N/A	Not Applicable
AM	Amplitude Modulation	NIST	National Institute of Standards and Technology
Amp, AMP	Amplifier	NS	No signal detect.
ANSI	American National Standards Institute	NSA	Normalized Site Attenuation
Ant, ANT	Antenna	NVLAP	National Voluntary Laboratory Accreditation Program
AP	Access Point	OBW	Occupied Band Width
ASK	Amplitude Shift Keying	OFDM	Orthogonal Frequency Division Multiplexing
Atten., ATT	Attenuator	P/M	Power meter
AV	Average	PCB	Printed Circuit Board
BPSK	Binary Phase-Shift Keying	PER	Packet Error Rate
BR	Bluetooth Basic Rate	PHY	Physical Layer
BT	Bluetooth	PK	Peak
BT LE	Bluetooth Low Energy	PN	Pseudo random Noise
BW	BandWidth	PRBS	Pseudo-Random Bit Sequence
Cal Int	Calibration Interval	PSD	Power Spectral Density
CCK	Complementary Code Keying	QAM	Quadrature Amplitude Modulation
Ch., CH	Channel	QP	Quasi-Peak
CISPR	Comite International Special des Perturbations Radioelectriques	QPSK	Quadri-Phase Shift Keying
CW	Continuous Wave	RBW	Resolution Band Width
DBPSK	Differential BPSK	RDS	Radio Data System
DC	Direct Current	RE	Radio Equipment
D-factor	Distance factor	RF	Radio Frequency
DFS	Dynamic Frequency Selection	RMS	Root Mean Square
DQPSK	Differential QPSK	RSS	Radio Standards Specifications
DSSS	Direct Sequence Spread Spectrum	Rx	Receiving
EDR	Enhanced Data Rate	SA, S/A	Spectrum Analyzer
EIRP, e.i.r.p.	Equivalent Isotropically Radiated Power	SG	Signal Generator
EMC	ElectroMagnetic Compatibility	SVSWR	Site-Voltage Standing Wave Ratio
EMI	ElectroMagnetic Interference	TR	Test Receiver
EN	European Norm	Tx	Transmitting
ERP, e.r.p.	Effective Radiated Power	VBW	Video BandWidth
EU	European Union	Vert.	Vertical
EUT	Equipment Under Test	WLAN	Wireless LAN
Fac.	Factor		
FCC	Federal Communications Commission		
FHSS	Frequency Hopping Spread Spectrum		
FM	Frequency Modulation		
Freq.	Frequency		
FSK	Frequency Shift Keying		
GFSK	Gaussian Frequency-Shift Keying		
GNSS	Global Navigation Satellite System		
GPS	Global Positioning System		
Hori.	Horizontal		
ICES	Interference-Causing Equipment Standard		
IEC	International Electrotechnical Commission		
IEEE	Institute of Electrical and Electronics Engineers		
IF	Intermediate Frequency		
ILAC	International Laboratory Accreditation Conference		
ISED	Innovation, Science and Economic Development Canada		
ISO	International Organization for Standardization		
JAB	Japan Accreditation Board		
LAN	Local Area Network		
LIMS	Laboratory Information Management System		

UL Japan, Inc. Shonan EMC Lab.

1-22-3 Megumigaoka, Hiratsuka-shi, Kanagawa-ken, 259-1220 JAPAN
Telephone : +81 463 50 6400
Facsimile : +81 463 50 6401

CONTENTS	PAGE
SECTION 1: Customer information.....	5
SECTION 2: Equipment under test (EUT).....	5
SECTION 3: Scope of Report.....	8
SECTION 4: Test specification, procedures & results.....	8
SECTION 5: Operation of EUT during testing.....	13
SECTION 6: Channel Move Time, Channel Closing Transmission Time.....	19
SECTION 7: Non-Occupancy Period.....	21
APPENDIX 1: Test instruments.....	23
APPENDIX 2: Photographs of test setup.....	24

SECTION 1: Customer information

Company Name : Sony Corporation, Japan and Sony Group Companies
Address : 1-7-1 Konan Minato-ku, Tokyo, 108-0075 Japan
Contact Person : Kazuhiko Nagano

The information provided from the customer is as follows;

- Applicant, Type of EUT, Model Number of EUT, FCC ID on the cover and other relevant pages
 - Operating/Test Mode(s) (Mode(s)) on all the relevant pages
 - SECTION 1: Customer information
 - SECTION 2: Equipment under test (EUT) other than the Receipt Date
 - SECTION 4: Operation of EUT during testing
- * The laboratory is exempted from liability of any test results affected from the above information in SECTION 2 and 4.

SECTION 2: Equipment under test (EUT)

2.1 Identification of EUT

Type : CONTROL BOX
Model Number : TMR-A9WT
Serial Number : Refer to SECTION 4.2
Rating : AC adapter Input: AC 100 V – 240 V, 50/60 Hz
DC 12 V
Receipt Date : October 18, 2020
Country of Mass-production : Malaysia
Condition : Engineering prototype
(Not for Sale: This sample is equivalent to mass-produced items.)
Modification : No Modification by the test lab

2.2 Product Description

Model: TMR-A9WT (referred to as the EUT in this report) is a CONTROL BOX.

Clock frequency of the EUT : 48 MHz (MAX) (Module A: WM-BAC-AT-49)
48 MHz (MAX) (Module B: 1PJ)

Radio Specification

<module A: model No. WM-BAC-AT-49> (* The module covered by this report.)

	Bluetooth (BR/EDR) *1)	Bluetooth (Low Energy) *1)
Frequency of operation	2402 MHz - 2480 MHz	2402 MHz - 2480 MHz
Channel spacing	1 MHz	2 MHz
Modulation	FHSS: GFSK (*, EDR: GFSK+ /4-DQPSK, GFSK+ 8DPSK)	
Antenna type	Dipole antenna	
Antenna Gain	3.54 dBi	
Antenna Connector type	U.FL connector	

*1) The Bluetooth part antenna and the Module B antenna are common antenna.

	IEEE802.11b	IEEE802.11g	IEEE802.11n (20 MHz band)	IEEE802.11n (40 MHz band)
Frequency of operation	2412 MHz - 2462 MHz	2412 MHz - 2462 MHz	2412 MHz - 2462 MHz 5180 MHz - 5240 MHz 5260 MHz - 5320 MHz 5500 MHz - 5720 MHz 5745 MHz - 5825 MHz	5190 MHz - 5230 MHz 5270 MHz - 5310 MHz 5510 MHz - 5710 MHz 5755 MHz - 5795 MHz
Channel spacing	5 MHz		2.4 GHz band 5 MHz 5 GHz band 20 MHz	5 GHz band 40 MHz
Modulation	DSSS: DBPSK, DQPSK, CCK	OFDM: BPSK, QPSK, 16QAM, 64QAM		
	IEEE802.11a	IEEE802.11ac (20 MHz band)	IEEE802.11ac (40 MHz band)	IEEE802.11ac (80 MHz band)
Frequency of operation	5180 MHz - 5240 MHz 5260 MHz - 5320 MHz 5500 MHz - 5720 MHz 5745 MHz - 5825 MHz	5180 MHz - 5240 MHz 5260 MHz - 5320 MHz 5500 MHz - 5720 MHz 5745 MHz - 5825 MHz	5190 MHz - 5230 MHz 5270 MHz - 5310 MHz 5510 MHz - 5710 MHz 5755 MHz - 5795 MHz	5210 MHz 5290 MHz 5530 MHz - 5610 MHz 5690 MHz 5775 MHz
Channel spacing	20 MHz		40 MHz	80 MHz
Modulation	OFDM BPSK, QPSK, 16QAM, 64QAM, 256QAM (*256QAM is only for IEEE802.11ac 80 MHz band)			
Antenna type	Dipole antenna			
Antenna Gain	ANT0 : 1.36 dBi (2.4 GHz), 3.71 dBi (U-NII-1), 2.60 dBi (U-NII-2A), 2.48 dBi (U-NII-2C), 3.09 dBi (U-NII-3) ANT1 : 1.90 dBi (2.4 GHz), 5.79 dBi (U-NII-1), 5.79 dBi (U-NII-2A), 5.12 dBi (U-NII-2C), 4.13 dBi (U-NII-3)			
Antenna Connector type	U.FL connector			

<module B: Model No. 1PJ>

	IEEE802.11a	IEEE802.11n (20 MHz band)	IEEE802.11n (40 MHz band)
Frequency of operation	5180 MHz - 5240 MHz 5260 MHz - 5320 MHz 5500 MHz - 5700 MHz 5745 MHz - 5825 MHz	5180 MHz - 5240 MHz 5260 MHz - 5320 MHz 5500 MHz - 5700 MHz 5745 MHz - 5825 MHz	5190 MHz - 5230 MHz 5270 MHz - 5310 MHz 5510 MHz - 5670 MHz 5755 MHz - 5795 MHz
Channel spacing	20 MHz	20 MHz	40 MHz
Modulation	DSSS: DBPSK, DQPSK, CCK	OFDM: BPSK, QPSK, 16QAM, 64QAM	
Antenna type	Dipole antenna		
Antenna Gain	ANT : 4.64 dBi (U-NII-1), 4.48 dBi (U-NII-2A), 4.76 dBi (U-NII-2C), 4.76 dBi (U-NII-3)		
Antenna Connector type	U.FL connector		

UL Japan, Inc. Shonan EMC Lab.

1-22-3 Megumigaoka, Hiratsuka-shi, Kanagawa-ken, 259-1220 JAPAN
Telephone : +81 463 50 6400
Facsimile : +81 463 50 6401

Additional information for specification:

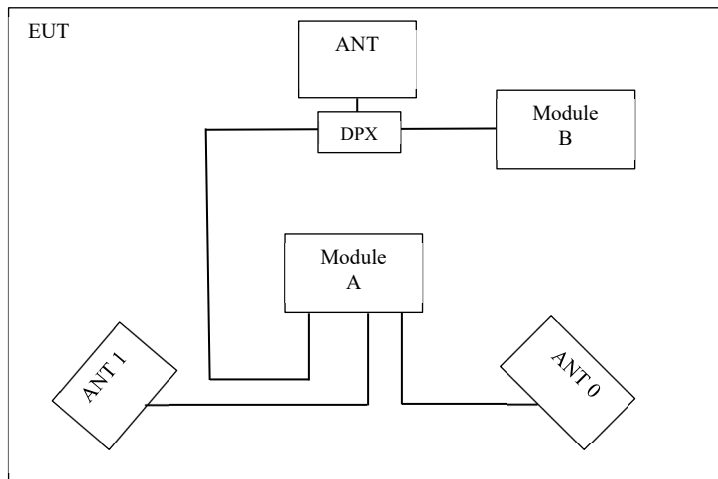

The EUT has module A and module B.

* DPX: Diplexer.

Combination of antennas used

	BT	BT LE	WLAN 2.4 GHz	WLAN 5 GHz
ANT	module A	module A	-	module B
ANT 0	-	-	module A	module A
ANT 1	-	-	module A	module A

UL Japan, Inc.
Shonan EMC Lab.

1-22-3 Megumigaoka, Hiratsuka-shi, Kanagawa-ken, 259-1220 JAPAN

Telephone : +81 463 50 6400

Facsimile : +81 463 50 6401

SECTION 3: Scope of Report

This report only covers DFS requirement, as specified by the following referenced procedures.

SECTION 4: Test specification, procedures & results

4.1 Test Specification

Test Specification	:	FCC Part 15 Subpart E FCC Part 15 final revised on January 12, 2021 and effective February 11, 2021 * The revision does not affect the test result conducted before its effective date.
Title	:	FCC 47CFR Part15 Radio Frequency Device Subpart E Unlicensed National Information Infrastructure Devices Section 15.407 General technical requirements
Test Specification	:	KDB905462 D02 UNII DFS Compliance Procedures New Rules v02
Title	:	COMPLIANCE MEASUREMENT PROCEDURES FOR UNLICENSED- NATIONAL INFORMATION INFRASTRUCTURE DEVICES OPERATING IN THE 5250-5350MHz AND 5470-5725MHz BANDS INCORPORATING DYNAMIC FREQUENCY SELECTION
Test Specification	:	KDB905462 D03 Client Without DFS New Rules v01r02
Title	:	U-NII CLIENT DEVICES WITHOUT RADAR DETECTION CAPABILITY

FCC Part 15.31 (e)

This EUT provides stable voltage constantly to RF Module regardless of input voltage. Therefore, this EUT complies with the requirement.

FCC Part 15.203 Antenna requirement

It is impossible for end users to replace the antenna, because the antenna is mounted inside of the EUT. Therefore, the equipment complies with the antenna requirement of Section 15.203.

4.2 Procedures and results

Table 1: Applicability of DFS Requirements

Requirement	Operating Mode	Test Procedures & Limits	Deviation	Results
	Client without Radar Detection			
U-NII Detection Bandwidth	Not required	KDB905462 D02 UNII DFS Compliance Procedures New Rules v02	N/A	N/A
Initial Channel Availability Check Time	Not required	FCC15.407 (h)	N/A	N/A
		KDB905462 D02 UNII DFS Compliance Procedures New Rules v02		
		RSS-247 6.3		
Radar Burst at the Beginning of the Channel Availability Check Time	Not required	FCC15.407 (h)	N/A	N/A
		KDB905462 D02 UNII DFS Compliance Procedures New Rules v02		
		RSS-247 6.3		
Radar Burst at the End of the Channel Availability Check Time	Not required	FCC15.407 (h)	N/A	N/A
		KDB905462 D02 UNII DFS Compliance Procedures New Rules v02		
		RSS-247 6.3		
In-Service Monitoring for Channel Move Time, Channel Closing Transmission Time	Yes	FCC15.407 (h)	N/A	Complied a)
		KDB905462 D02 UNII DFS Compliance Procedures New Rules v02		
		RSS-247 6.3		
In-Service Monitoring for Non-Occupancy period	Yes *	FCC15.407 (h)	N/A	Complied b)
		KDB905462 D02 UNII DFS Compliance Procedures New Rules v02		
		RSS-247 6.3		
Statistical Performance Check	Not required	FCC15.407 (h)	N/A	N/A
		KDB905462 D02 UNII DFS Compliance Procedures New Rules v02		
Note: UL Japan, Inc.'s EMI Work Procedures No. 13-EM-W0422.				
a) Refer to SECTION 6, clause 6.3				
b) Refer to SECTION 7, clause 7.3				
Symbols:				
Complied The data of this test item has enough margin, more than the measurement uncertainty.				
Complied# The data of this test item meets the limits unless the measurement uncertainty is taken into consideration.				

*Although this test was not required in FCC, KDB 905462 D02, it was performed as additional test.

UL Japan, Inc. Shonan EMC Lab.

1-22-3 Megumigaoka, Hiratsuka-shi, Kanagawa-ken, 259-1220 JAPAN
Telephone : +81 463 50 6400
Facsimile : +81 463 50 6401

Table 2 DFS Detection Thresholds for Master Devices and Client Devices With Radar Detection

Maximum Transmit Power	Value (See Notes 1,2, and 3)
≥ 200 milliwatt	-64 dBm
< 200 milliwatt and power spectral density < 10 dBm/MHz	-62 dBm
< 200 milliwatt that do not meet the power spectral density requirement	-64 dBm
<p>Note 1: This is the level at the input of the receiver assuming a 0 dBi receive antenna.</p> <p>Note 2: Throughout these test procedures an additional 1 dB has been added to the amplitude of the test transmission waveforms to account for variations in measurement equipment. This will ensure that the test signal is at or above the detection threshold level to trigger a DFS response.</p> <p>Note 3: EIRP is based on the highest antenna gain. For MIMO devices refer to KDB Publication 662911 D01.</p>	

Table 3 DFS Response Requirement Values

Parameter	Value
Non-occupancy period	Minimum 30 minutes
Channel Availability Check Time	60 seconds
Channel Move Time	10 seconds See Note 1
Channel Closing Transmission Time	200 milliseconds + an aggregate of 60 milliseconds over remaining 10 second period. See Notes 1 and 2
U-NII Detection Bandwidth	Minimum 100 % of the U-NII 99 % transmission power bandwidth See Note 3
<p>Note 1: Channel Move Time and the Channel Closing Transmission Time should be performed with Radar Type 0. The measurement timing begins at the end of the Radar Type 0 burst.</p> <p>Note 2: The Channel Closing Transmission Time is comprised of 200 milliseconds starting at the beginning of the Channel Move Time plus any additional intermittent control signals required to facilitate a Channel move (an aggregate of 60 milliseconds) during the remainder of the 10 second period. The aggregate duration of control signal will not count quiet periods in between transmissions.</p> <p>Note 3: During the U-NII Detection Bandwidth detection test, radar type 0 should be used. For each frequency step the minimum percentage of detection is 90 percent. Measurements are performed with no data traffic.</p>	

Table 4 Short Pulse Radar Test Waveform

Radar Type	Pulse Width (μsec)	PRI (μsec)	Number of Pulses	Minimum Percentage of Successful Detection	Minimum Number of Trials
0	1	1428	18	See Note 1	See Note 1
1	1	Test A: 15 unique PRI values randomly selected from the list of 23 PRI values in Table 5a	Roundup{(1/360)* (19*10 ⁶ /PRI μsec)}	60 %	30
		Test B: 15 unique PRI values randomly selected within the range of 518-3066 μsec, with a minimum increment of 1 μsec, excluding PRI values selected in Test A			
2	1-5	150-230	23-29	60 %	30
3	6-10	200-500	16-18	60 %	30
4	11-20	200-500	12-16	60 %	30
Aggregate (Rader Types 1-4)				80 %	120
Note 1: Short Pulse Radar Type 0 should be used for the detection bandwidth test, channel move time, and channel closing time tests.					

Table 5 Long Pulse Radar Test Waveform

Radar Type	Pulse Width (μsec)	Chip Width (MHz)	PRI (μsec)	Number of Pulses per Burst	Number of Burst	Minimum Percentage of Successful Detection	Minimum Number of Trials
5	50-100	5 - 20	1000-2000	1-3	8-20	80 %	30

Table 6 Frequency Hopping Radar Test Waveform

Radar Type	Pulse Width (μsec)	PRI (μsec)	Pulse per Hop (kHz)	Hopping Rate (kHz)	Hopping Sequence Length (msec)	Minimum Percentage of Successful Detection	Minimum Number of Trials
6	1	333	9	0.333	300	70 %	30

4.3 Addition to standard

No addition, exclusion nor deviation has been made from the standard.

**UL Japan, Inc.
Shonan EMC Lab.**

1-22-3 Megumigaoka, Hiratsuka-shi, Kanagawa-ken, 259-1220 JAPAN
Telephone : +81 463 50 6400
Facsimile : +81 463 50 6401

4.4 Test Location

UL Japan, Inc. Shonan EMC Lab.

1-22-3, Megumigaoka, Hiratsuka-shi, Kanagawa-ken 259-1220 JAPAN

Telephone: +81 463 50 6400, Facsimile: +81 463 50 6401

A2LA Certificate Number: 1266.03

(FCC test firm registration number: 626366, ISED lab company number: 2973D / CAB identifier: JP0001)

Test site	IC Registration Number	Width x Depth x Height (m)	Size of reference ground plane (m) / horizontal conducting plane	Maximum measurement distance
No.1 Semi-anechoic chamber	2973D-1	20.6 x 11.3 x 7.65	20.6 x 11.3	10 m
No.2 Semi-anechoic chamber	2973D-2	20.6 x 11.3 x 7.65	20.6 x 11.3	10 m
No.3 Semi-anechoic chamber	2973D-3	12.7 x 7.7 x 5.35	12.7 x 7.7	5 m
No.4 Semi-anechoic chamber	-	8.1 x 5.1 x 3.55	8.1 x 5.1	-
No.1 Shielded room	-	6.8 x 4.1 x 2.7	6.8 x 4.1	-
No.2 Shielded room	-	6.8 x 4.1 x 2.7	6.8 x 4.1	-
No.3 Shielded room	-	6.3 x 4.7 x 2.7	6.3 x 4.7	-
No.4 Shielded room	-	4.4 x 4.7 x 2.7	4.4 x 4.7	-
No.5 Shielded room	-	7.8 x 6.4 x 2.7	7.8 x 6.4	-
No.6 Shielded room	-	7.8 x 6.4 x 2.7	7.8 x 6.4	-
No.8 Shielded room	-	3.45 x 5.5 x 2.4	3.45 x 5.5	-
No.1 Measurement room	-	2.55 x 4.1 x 2.5	-	-

4.5 Uncertainty

The following uncertainties have been calculated to provide a confidence level of 95% using a coverage factor k=2. Time Measurement uncertainty for this test was: (\pm) 0.012%

4.6 Test instruments of DFS and Test set up

Refer to APPENDIX.

UL Japan, Inc. Shonan EMC Lab.

1-22-3 Megumigaoka, Hiratsuka-shi, Kanagawa-ken, 259-1220 JAPAN

Telephone : +81 463 50 6400

Facsimile : +81 463 50 6401

SECTION 5: Operation of EUT during testing

5.1 Operating Modes

The EUT, which is a Client Device without Radar detection capability, operates over the W53 and W56 Band.

The channel-loading of approximately 17 % or greater was used for testing, and its test data was transferred from the Master Device to the Client Device for all test configurations.

WLAN traffic is generated random data by iperf program from the Master to the Client.

The EUT utilizes the 802.11a/n/ac architecture, with a 20 MHz, 40 MHz and 80 MHz channel bandwidth.

The FCC ID for the Master Device used with EUT for DFS testing is LDK102073.

The rated output power of the Master unit is >200 mW (23 dBm). Therefore the required interference threshold level is -64 dBm. After correction for antenna gain and procedural adjustments, the required conducted threshold at the antenna port is $-64 + 1 + 4 = -59.0$ dBm (threshold level + additional 1 dB + antenna gain).

It is impossible for users to change DFS control, because the DFS function is written on the firmware and users cannot access it.

The EUT was set by the software as follows:

Software name & version: AT-49 STA Tool v1.0 (for EUT), iperf.exe ver.2.0.5.2 (for Master Device)

5.2 Configuration and peripherals

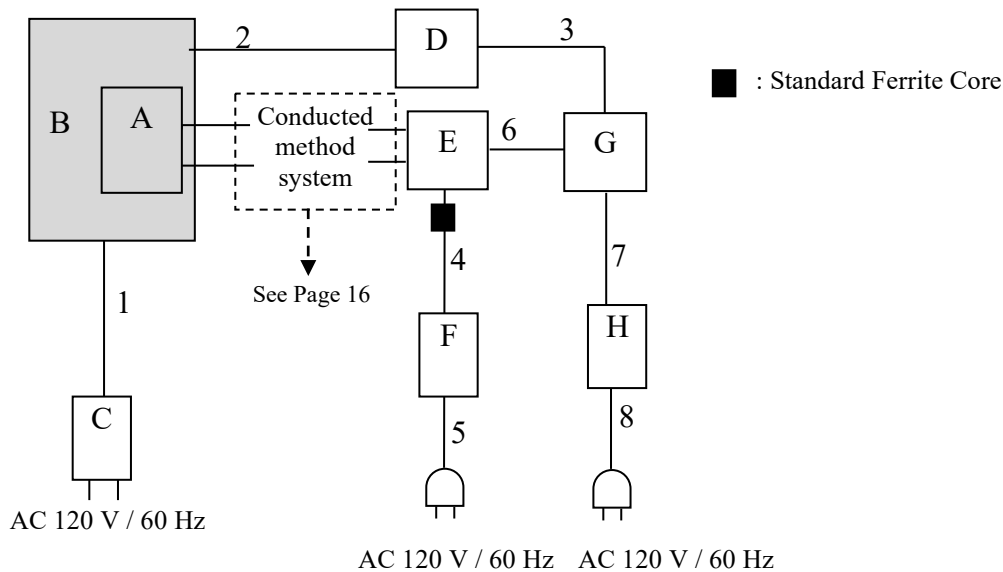

Description of EUT and Support equipment

No.	Item	Model number	Serial number	Manufacturer	Remarks
A	802.11a/b/g/n/ac 2x2 MIMO + BT 5.1 Combo Module	WM-BAC-AT-49	G036	USI	EUT
B	CONTROL BOX	TMR-A9WT	036	Sony Corporation	EUT
C	AC Adapter	AC-M1215UC	M2090660255	Sony Corporation	-
D	Jig Board (serial I/F)	-	-	Sony Corporation	-
E	Wireless LAN access point (Master device)	AIR-CAP3702E- A-K9	FTX18227609	Cisco systems	FCC ID: LDK102073, ISED No. 2461B-102073
F	AC Adapter	EADP-18MB	DAB1528MANP	Cisco systems	-
G	Laptop Computer	dynabook Satellite B453 M	ZE127581H	TOSHIBA	-
H	AC Adapter	PA3917U-1ACA	G71C000DP410	TOSHIBA	-

List of cables used

No.	Cable name	Length (m)	Shield	
			Cable	Connector
1	DC cable	1.5	Unshielded	Unshielded
2	Signal cable	0.2	Unshielded	Unshielded
3	USB cable	0.7	Shielded	Shielded
4	DC cable	1.8	Unshielded	Unshielded
5	AC cable	2.0	Unshielded	Unshielded
6	LAN cable	1.0	Unshielded	Unshielded
7	DC cable	1.7	Unshielded	Unshielded
8	AC cable	0.8	Unshielded	Unshielded

UL Japan, Inc. Shonan EMC Lab.

1-22-3 Megumigaoka, Hiratsuka-shi, Kanagawa-ken, 259-1220 JAPAN
Telephone : +81 463 50 6400
Facsimile : +81 463 50 6401

5.3 Test and Measurement System

SYSTEM OVERVIEW

The measurement system is based on a conducted test method.

The software selects waveform parameters from within the bounds of the signal type on a random basis using uniform distribution. The short pulse types 1, 2, 3, and 4, the long pulse type 5, and the frequency hopping type 6 parameters are randomized at run-time.

The signal monitoring equipment consists of a spectrum analyzer with the capacity to display 8001 bins on the horizontal axis. A time-domain resolution of 2 ms/bin is achievable with a 16 second sweep time, meeting the 10 seconds short pulse reporting criteria. The aggregate ON time is calculated by multiplying the number of bins above a threshold during a particular observation period by the dwell time per bin, with the analyzer set to peak detection.

FREQUENCY HOPPING RADAR WAVEFORM GENERATING SUBSYSTEM

The first 100 frequencies are selected out of the hopping sequence of the randomized 475 hop frequencies. Only a *Burst* that has the frequency falling within the receiver bandwidth of the tested U-NII device is selected among those frequencies. (Frequency-domain simulation). The radar waveform generated at the start time of the selected *Burst* (Time-domain simulation) is download to the Signal Generator. If all of the randomly selected 100 frequencies do not fall within the receiver bandwidth of the U-NII device, the radar waveform is not used for the test.

CONDUCTED METHODS SYSTEM BLOCK DIAGRAM

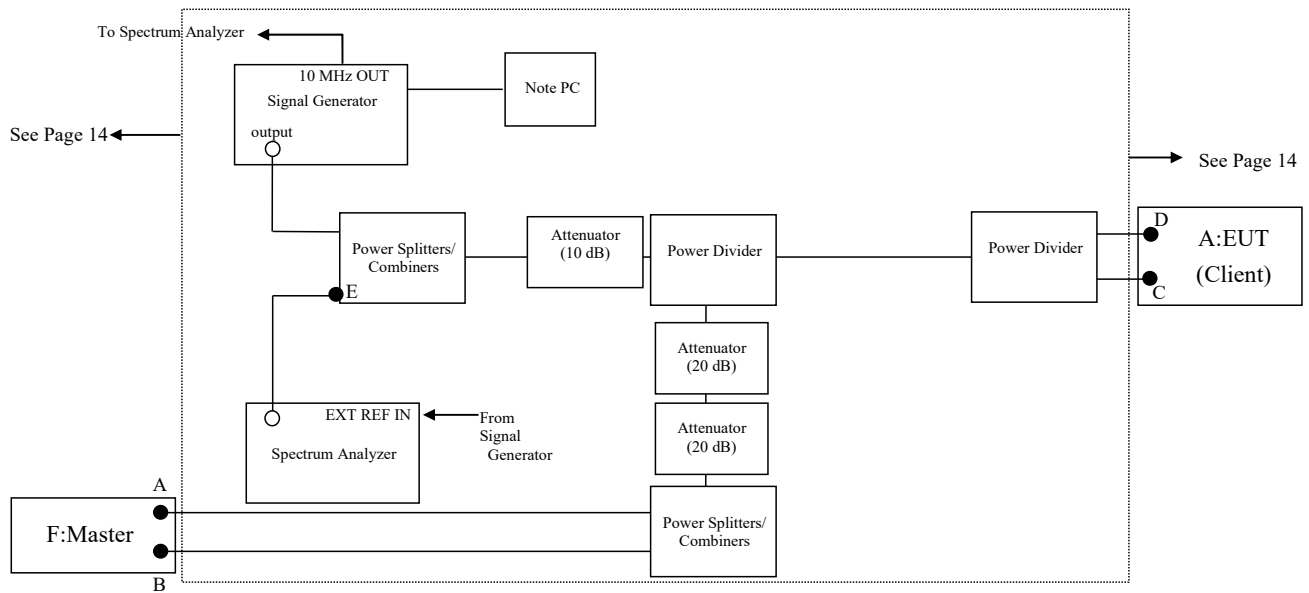

MEASUREMENT SYSTEM FREQUENCY REFERENCE

Lock the signal generator and the spectrum analyzer to the same reference sources as follows: Connect the 10 MHz OUT on the signal generator to the EXT REF IN on the spectrum analyzer and set the spectrum analyzer Ext to On.

SYSTEM CALIBRATION

Step 1: Set the system as shown in Figure 3 of KDB905462 D02 7.2.2.

Step 2: Adjust each attenuator to fulfill the following three conditions:

- WLAN can be communicated, and
- Rader detection threshold level is bigger than Client Device traffic level on the spectrum analyzer, and
- Master Device traffic level is not displayed on the spectrum analyzer.

Step 3: Terminate 50 ohm at B, C, D and E points, and connect the spectrum analyzer to the point A. (See the figure of CONDUCTED METHODS SYSTEM BLOCK DIAGRM on Section 5, Clause 3)

At the point A, adjust the signal generator and spectrum analyzer to the center frequency of the channel to be measured.

Download the applicable radar waveforms to the signal generator. Select the radar waveform, trigger a burst manually and measure the amplitude on the spectrum analyzer. Readjust the amplitude of the signal generator as required so that the peak level of the waveform is at a displayed level equal to the required or desired interference detection threshold.

Separate signal generator amplitude settings are determined as required for each radar type.

Step 4: Without changing any of the instrument settings, restore the system setting to Step 2 and adjust the Reference Level Offset of the spectrum analyzer to the level at Step 3.

By taking the above steps 1 to 4, the spectrum analyzer displays the level of the signal generator as received at the antenna ports of the Master Device.

See Clause 5.4 for Plots of Noise, Rader Waveforms, and WLAN signals.

5.4 Plots of Noise, Rader Waveforms, and WLAN signals

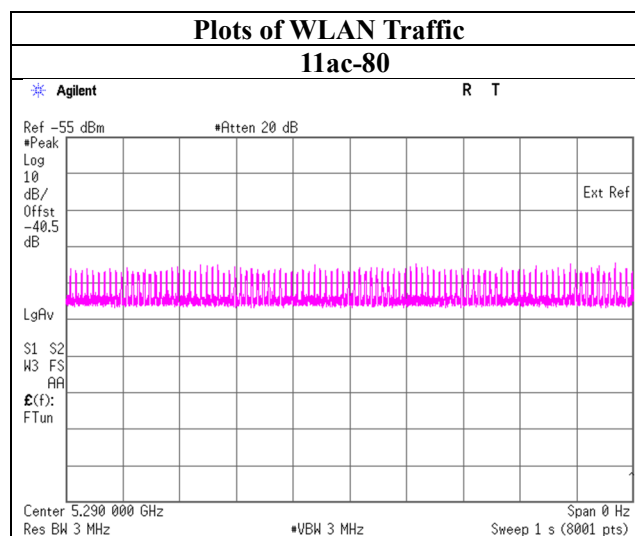
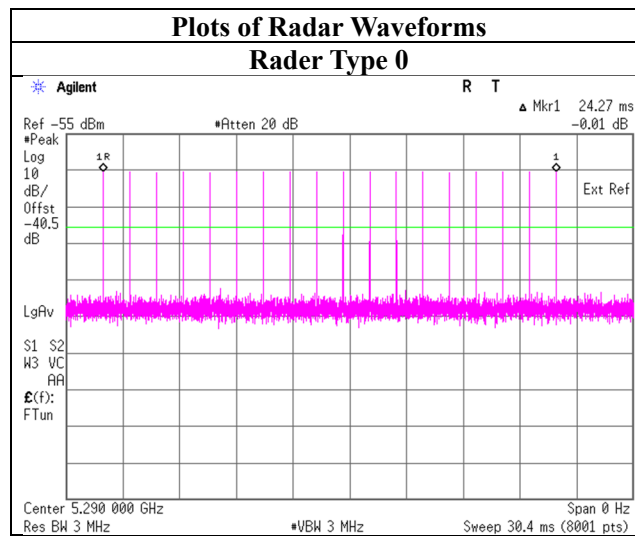
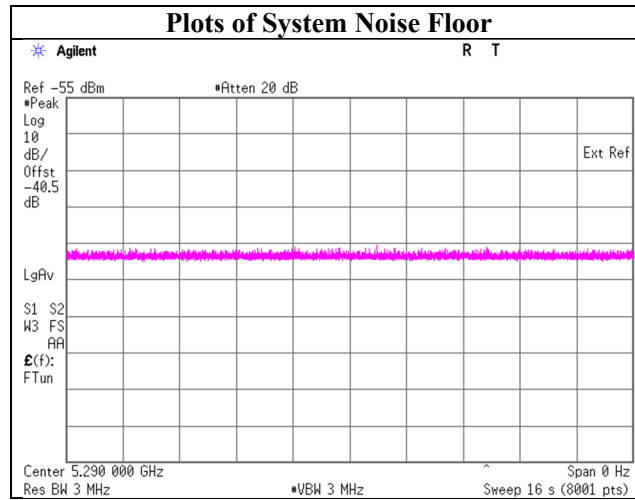

UL Japan, Inc.
Shonan EMC Lab.

1-22-3 Megumigaoka, Hiratsuka-shi, Kanagawa-ken, 259-1220 JAPAN
 Telephone : +81 463 50 6400
 Facsimile : +81 463 50 6401

SECTION 6: Channel Move Time, Channel Closing Transmission Time

6.1 Operating environment

Report No. 13554183S-F
Test place Shonan EMC Lab. No.5 Shielded Room
Date November 13, 2020
Temperature / Humidity 26 deg. C / 51 % RH
Engineer Kenichi Adachi
Mode 11ac-80

6.2 Test Procedure

Transmit the data from the Master Device to the Client Device on the test Channel for the entire period of the test. The Radar Waveform generator sends a Burst of pulses for one of the Short Pulse Radar Types 0 at levels defined , on the Operating Channel. An additional 1 dB is added to the radar test signal to ensure it is at or above the DFS Detection Threshold, accounting for equipment variations/errors.

Observe the transmissions of the EUT at the end of the radar Burst on the Operating Channel for duration greater than 10 seconds.

6.3 Test data

11ac-80

Test Item	Unit	Measurement Time	Limit	Results
Channel Move Time *1)	[s]	0.020	10.000	Pass
Channel Closing Transmission Time *2)	[ms]	0	60	Pass

*1) Channel Move Time is calculated as follows:

$$(\text{Channel Move Time}) = (\text{End of Transmission}) - (\text{End of Burst}) = 0.544 - 0.524$$

*2) Channel Closing Transmission Time is calculated from (End of Burst + 200 ms) to (End of Burst + 10 s)

$$(\text{Channel Closing Transmission Time}) = (\text{Number of analyzer bins showing transmission}) \times (\text{dwell time per bin}) \\ = 0 \times 2 [\text{ms}]$$

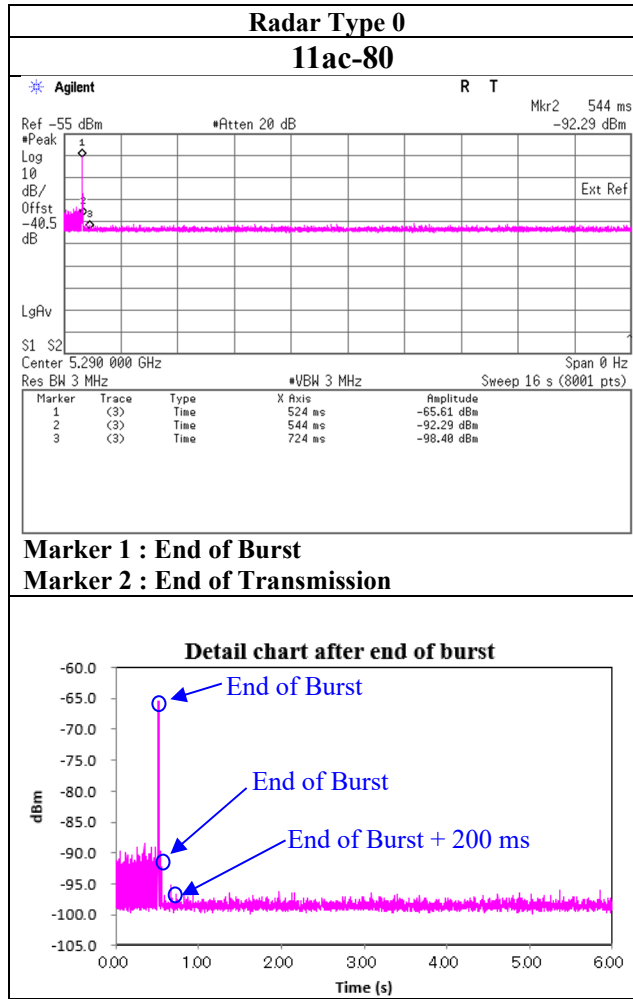

6.4 Test result

Test result: Pass

SECTION 7: Non-Occupancy Period

7.1 Operating environment

Report No.	13554183S-F
Test place	Shonan EMC Lab. No.5 Shielded Room
Date	November 13, 2020
Temperature / Humidity	26 deg. C / 51 % RH
Engineer	Kenichi Adachi
Mode	11ac-80

7.2 Test Procedure

The following two tests are performed:

- 1). Transmit the data from the Master Device to the Client Device on the test Channel for the entire period of the test. The Radar Waveform generator sends a Burst of pulses for one of the Radar Types 0 at levels defined on the Operating Channel. An additional 1 dB is added to the radar test signal to ensure it is at or above the DFS Detection Threshold, accounting for equipment variations/errors. Observe the transmissions of the EUT after the Channel Move Time on the Operating Channel for duration greater than 30 minutes.
- 2). Transmit the data from the Master Device to the Client Device on the test Channel for the entire period of the test. Observe the transmissions of the EUT on the Operating Channel for duration greater than 30 minutes after the Master Device is shut off.

7.3 Test data

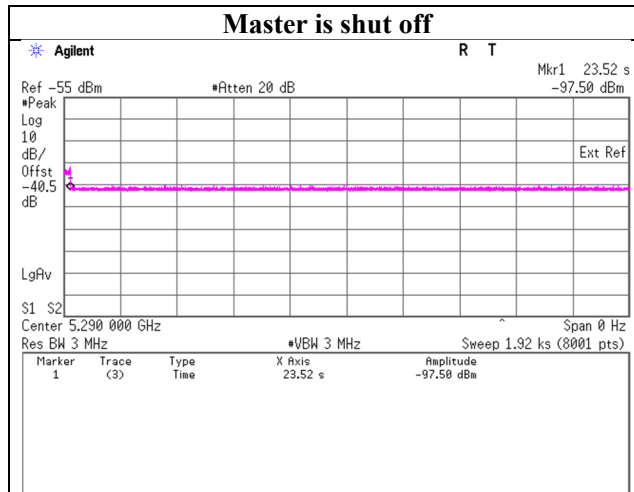
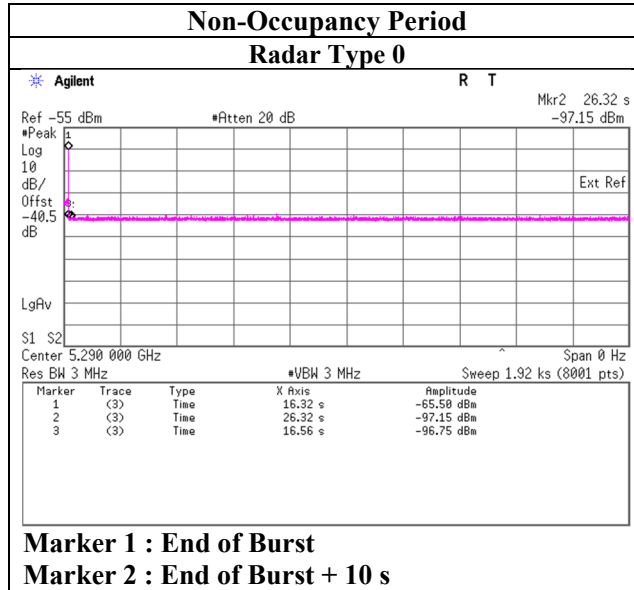

7.4 Test result

Test result: Pass

APPENDIX 1: Test instruments

Test equipment

Test Name	Local ID	LIMS ID	Description	Manufacturer	Model	Serial	Last Calibration Date	Calibration Interval (Month)
DFS	CSG-12	143677	Signal Generator	Keysight Technologies Inc	N5182B	MY53050599	2020/07/22	12
DFS	SCC-G11	145174	Coaxial Cable	Suhner	SUCOFLEX 102	31595/2	2020/03/02	12
DFS	SCC-G24	145181	Coaxial Cable	Suhner	141PE	-	2020/07/15	12
DFS	SCC-G25	145182	Coaxial Cable	Suhner	141PE	-	2020/07/15	12
DFS	SCC-G60	196941	Coaxial Cable	HUBER+SUNER	SUCOFLEX 102	803093/2	2020/03/10	12
DFS	SCC-G61	196937	Coaxial Cable	HUBER+SUNER	SUCOFLEX 102	803605/2	2020/03/10	12
DFS	SCC-G63	196946	Coaxial Cable	HUBER+SUNER	SUCOFLEX 102	803411/2	2020/03/10	12
DFS	SCC-H20	159940	Microwave cable	RS Pro	R-132G7210 100CO	-	2020/10/06	12
DFS	SCC-H21	197395	Microwave cable	RS Pro	R-132G7210 100CO	-	2020/04/07	12
DFS	SPD-01	146261	Power Divider	Keysight Technologies Inc	11636B	56998	2020/04/01	12
DFS	SPSC-14	157772	Power Splitters/Combiners	Mini-Circuits	ZFSC-2-10G-S+	-	2020/08/05	12
DFS	SPSC-15	157774	Power Splitters/Combiners	Mini-Circuits	ZFSC-2-10G-S+	-	2020/08/05	12
DFS	SRE-157	145693	Wireless LAN access point	Cisco Systems	AIR-CAP3702E-A-K9	FTX18227609	-	-
DFS	COTS-SDFS-03	176615	Signal Studio for DFS Rader Profiles	EMC Instruments Corporation	N7607C	-	-	-
DFS	KSA-08	145089	Spectrum Analyzer	Keysight Technologies Inc	E4446A	MY46180525	2019/11/05	12
DFS	SAT10-12	151609	Attenuator	Weinschel Corp.	54A-10	81601	2020/03/02	12
DFS	SAT20-12	160495	Attenuator	Weinschel Corp.	54A-20	86752	2019/12/12	12
DFS	SAT20-13	160496	Attenuator	Weinschel Corp.	54A-20	87636	2019/12/12	12
DFS	SCC-G65	196942	Coaxial Cable	HUBER+SUNER	SUCOFLEX 102	803416/2	2020/03/10	12
DFS	SPSC-08	146277	Power Splitters/Combiners	Mini-Circuits	ZFSC-2-10G+	-	2019/11/18	12

***Hyphens for Last Calibration Date and Cal Int (month) are instruments that Calibration is not required (e.g. software), or instruments checked in advance before use.**

***1) Signal generator is only used to generate radar test signal, and the wave form is confirmed with spectrum analyzer every time before the test.**

The expiration date of the calibration is the end of the expired month.

As for some calibrations performed after the tested dates, those test equipment have been controlled by means of an unbroken chains of calibrations.

All equipment is calibrated with valid calibrations. Each measurement data is traceable to the national or international standards.

Test item:

DFS: Dynamic Frequency Selection

UL Japan, Inc.

Shonan EMC Lab.

1-22-3 Megumigaoka, Hiratsuka-shi, Kanagawa-ken, 259-1220 JAPAN

Telephone : +81 463 50 6400

Facsimile : +81 463 50 6401