



---

# TEST REPORT

---

**REPORT NUMBER** : ANKK-103108  
**APPLICANT** : Sony Corporation  
**MODEL NUMBER** : PCWA-C300S  
**FCC ID** : AK8PCWAC300S  
**IC** : 409B-PCWAC300  
**REGULATION** : FCC Part15 Subpart C  
: Industry Canada RSS-210 Issue 5



NVLAP accreditation is valid for  
FCC Part15 (Digital Devices),  
CISPR22 and AS/NZS 3548.  
NVLAP accreditation does not cover  
ICES-003.

**Akzo Nobel K. K.**  
**EMC Division**  
**Kashima Site**

**1, Oaza Sunayama, Hasaki-machi, Kashima-gun**  
**Ibaraki-ken, 314-0255 Japan**  
**Tel.: +81 479 40 1097 Fax.: +81 479 46 1788**

**TABLE OF CONTENTS**

---

	Page
ABBREVIATIONS .....	3
SECTION 1. TEST CERTIFICATION .....	4
SECTION 2. SUMMARY OF RESULTS .....	5
SECTION 3. EQUIPMENT UNDER TEST .....	6
SECTION 4. SUPPORT EQUIPMENT USED .....	8
SECTION 5. CABLE (S) USED .....	9
SECTION 6. CONSTRUCTION OF EQUIPMENT .....	10
SECTION 7. GENERAL TEST CONDITIONS .....	11
SECTION 8. TEST PROCEDURE(S) .....	12
SECTION 9. TEST DATA .....	16
9.1 Minimum 6dB Bandwidth [15.247(a)(2)] .....	16
9.2 Maximum Peak Output Power [15.247(b)] .....	22
9.3 Power Spectral Density [15.247(d)] .....	25
9.4 Spurious Emissions – RF Antenna Conducted Test [15.247(c)] .....	31
9.5 Spurious Emissions – Radiated Emission Test [15.247(c), 15.205, 15.209] .....	33
9.6 Restricted Bands of Operation [15.247(c), 15.205, 15.209] .....	49
9.7 AC Conducted Emissions [15.207] .....	63
SECTION 10. MEASUREMENT UNCERTAINTY .....	67
SECTION 11. DESCRIPTION OF TEST LABORATORY .....	68

---

**ABBREVIATIONS**

**LISN** = Line Impedance Stabilization Network

**AMN** = Artificial Mains Network

**ANT** = Antenna

**BBA** = Broad-band Antenna

**DIP** = Dipole Antenna

**AMP** = Amplifier

**ATT** = Attenuator

**EUT** = Equipment Under Test

**Q-P** = Quasi-peak

**AVG** = Average

**Ch** = Channel

**EIRP** = Effective Isotropic Radiated Power

**SECTION 1. TEST CERTIFICATION****APPLICANT INFORMATION**

Company	: Sony Corporation
Address	: 6-7-35, Kitashinagawa, Shinagawa-ku, Tokyo, 141-0001 Japan
Telephone number	: +81 3 5795 8712
Fax number	: +81 3 5795 8981

**DESCRIPTION OF TEST ITEM**

Kind of equipment	: Wireless LAN PC Card
Condition of equipment	: Pre Production
Type	: Tabletop
Trademark	: SONY
FCC ID	: AK8PCWAC300S
IC	: 409B-PCWAC300
Model number	: PCWA-C300S
Serial number	: 0000005

**TEST PERFORMED**

Location	: Kashima No. 3 Test Site (FCC Reg. No. : 90433) (IC File No. : IC 2065-3)
EUT received	: April 7, 2003
Test started	: April 7, 2003
Test completed	: April 14, 2003
Regulation	: FCC Part15 Subpart C Section 15.247 Intentional Radiators : Industry Canada RSS-210 Issue 5 Low Power Licence-Exempt Radiocommunication Devices (All Frequency Bands)
Test setup	: ANSI C63.4-1992

Report issue date : April 17, 2003

Test engineer : Yasuhiro Kase



Test engineer : Kazuhiro Ando



Report approved by : Takeshi Yamanaka  
[Site Manager]



**On the basis of the measurements made, the equipment tested is capable of operation in compliance with the requirements of Part 15 of the FCC Rules under normal use and maintenance.**

**Note**

- The test result of this report is effective for equipment under test itself and under the test configuration described on the report.
- This test report does not assure that whether the test result taken in other testing laboratory is compatible or reproducible to the test result on this report or not.
- This test report shall not be reproduced except in full, without issuer's permission.

**SECTION 2. SUMMARY OF RESULTS**

<b>Test</b>	<b>Reference (FCC)</b>	<b>Reference (IC)</b>	<b>Result</b>
Minimum 6dB Bandwidth	15.247(a)(2)	5.9.1	Pass
Maximum Peak Output Power	15.247(b)	6.2.2(o)(b)	Pass
Spurious Emissions - RF Antenna Conducted Test	15.247(c)	6.2.2(o)(e1)	Pass
Spurious Emissions - Radiated Emission Test	15.247(c) 15.205 15.209	6.2.2(o)(e1)	Pass
Restricted Bands of Operation	15.247(c) 15.205 15.209	6.2.1 6.3	Pass
Power Spectral Density	15.247(d)	6.2.2(o)(b)	Pass
AC Conducted Emission	15.207	6.6	Pass

Note : As for the FCC Part 15 Subpart B-Unintentional Radiators, the EUT has been measured and declared as DoC by Sony Corporation.

**SECTION 3. EQUIPMENT UNDER TEST**

The equipment under test (EUT) consisted of the following equipment.  
Indication in the following left side column corresponds to Section 6.

Symbol	Item	Model No.	Serial No.	FCC ID / DoC	Manufacturer	Remarks
A)	Wireless LAN PC Card	PCWA-C300S	0000005	AK8PCWAC300S	Sony Corporation	

Power ratings of EUT : DC 3.3V, Max. 700mA

DoC : Device for Declaration of Conformity

**3.1 Overview of EUT****3.1.1 Modulation Method : 2.4GHz DS-SS**

Operating Frequency Range	2400 – 2483.5 MHz	
Standard	IEEE 802.11g(Draft)	
Number of Operating Channel	11	
Data Transfer Rate	1Mbps / 2Mbps / 5.5Mbps / 11Mbps	
Antenna Gain	Antenna A	1.16 dBi
	Antenna B	1.20 dBi
Output Power	20.4 mW	
EIRP	26.9 mW	

**3.1.1 Modulation Method : 2.4GHz OFDM**

Operating Frequency Range	2400 – 2483.5 MHz	
Standard	IEEE 802.11g(Draft)	
Number of Operating Channel	11	
Data Transfer Rate	6Mbps / 9Mbps / 12Mbps / 18Mbps 24Mbps / 36Mbps / 48Mbps / 54Mbps	
Antenna Gain	Antenna A	1.16 dBi
	Antenna B	1.20 dBi
Output Power	30.9 mW	
EIRP	40.7 mW	

### 3.2 Operating channels and frequencies

Ch	Frequency (MHz)	Ch	Frequency (MHz)
1	2412	7	2442
2	2417	8	2447
3	2422	9	2452
4	2427	10	2457
5	2432	11	2462
6	2437		

**Note:**

1. This is for sure that all frequencies are in 2412 MHz to 2462 MHz.
2. Section 15.31(m): Measurements on intentional radiators or receivers shall be performed at three frequencies for operating frequency range over 10 MHz. (The locations of these frequencies one near the low, one near the middle and one near the high.)
3. After test, the EUT operating frequencies are in 2412 MHz to 2462 MHz. So all the items as followed in testing report are need to test these three frequencies: low: Ch 1, middle: Ch 6, high: Ch 11.

### 3.3 Port(s)/Connector(s) :

Port name	Connector type	Connector pin	Remarks
Card Bus Port	PC Card Card Bus	68 pin	

### 3.4 Oscillator(s)/Crystal(s) :

Oscillator	Operating frequency	Board name	Remarks
32 MHz	40 MHz	WLC3020 - D92	
	32 MHz	WLC3020 - D92	
	22 MHz	WLC3020 - D92	
	1.116 - 1.126 GHz	WLC3020 - D92	
	2.412 - 2.462 GHz	WLC3020 - D92	
	4.464 - 4.504GHz	WLC3020 - D92	
	5.580 - 5.630GHz	WLC3020 - D92	Highest frequency

**SECTION 4. SUPPORT EQUIPMENT USED**

The EUT was supported by the following equipment during the test.  
Indication in the following left side column corresponds to Section 6.

Symbol	Item	Model No.	Serial No.	FCC ID / DoC	Manufacturer	Remarks
B)	Computer	PVC-MXS20	100000060	DoC	Sony Corporation	
C)	CRT Display	E551	MY-044NEK-46632-0BF-9065	DoC	Dell	
D)	Keyboard	PCVA-KB2P/JC	100000058	DoC	Sony Corporation	
E)	Mouse	1-796-183-31	100000060	DoC	Sony Corporation	
F)	Modem	C202A	010058	BKM552C202A	EPSON	
G)	Printer	P12PB	0E11397879	BKM9A8P12PB	EPSON	
H)	AC Adapter	H00CAA	019546	N.A.	EPSON	

DoC : Device was tested and authorized under a Declaration of Conformity to the applicable FCC rules.



**SECTION 5. CABLE (S) USED**

The following cable(s) was used for the test.

Indication number in the following left side column corresponds to Section 6.

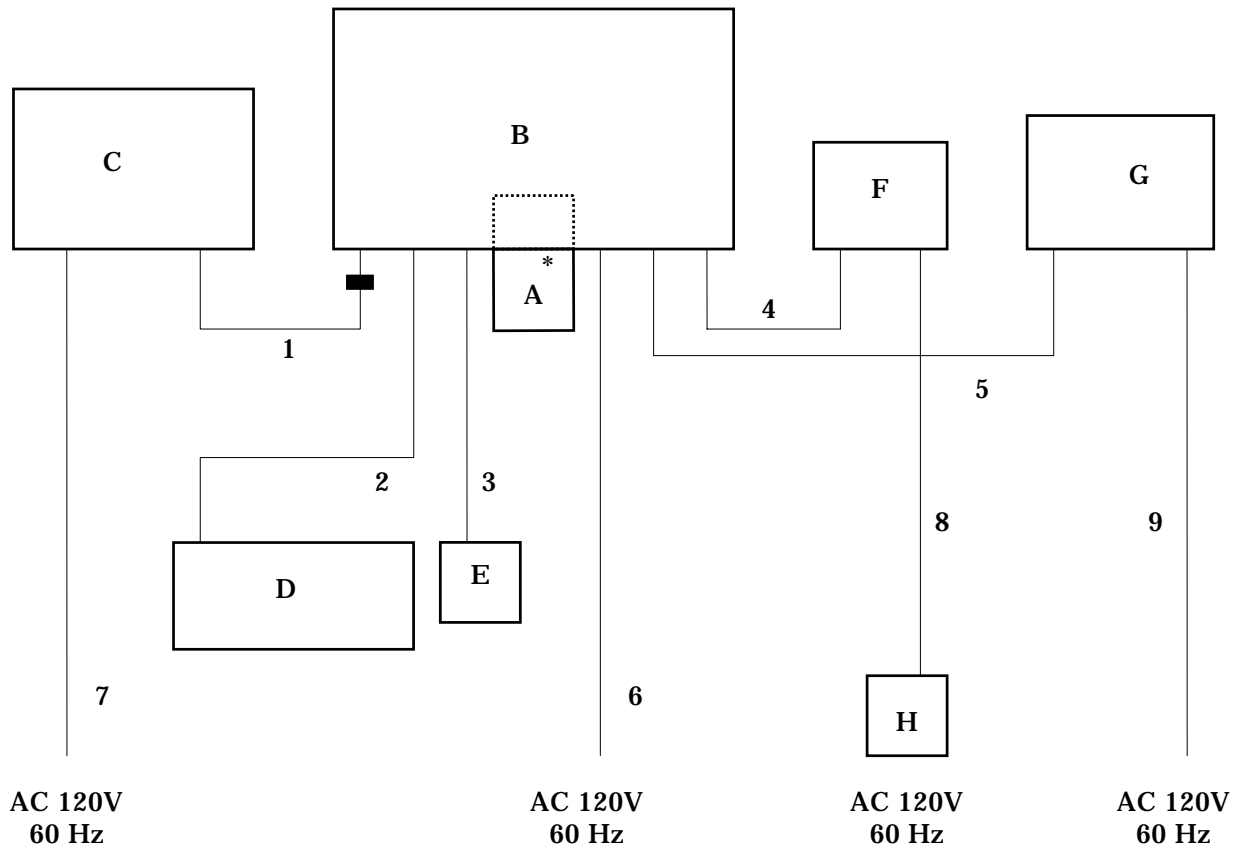
Number	Name	Length	Shield	Connector	Core
1)	Video cable	1.70 m	Yes	Metal	Fixed ×1
2)	Keyboard cable	1.80 m	Yes	Metal	
3)	Mouse cable	1.80 m	Yes	Metal	
4)	RS-232C cable	2.40 m	Yes	Metal	
5)	Centronics cable	2.40 m	Yes	Metal	
6)	Power cable for Computer	1.80 m	None		
7)	Power cable for CRT Display	1.90 m	None		
8)	Power cable for Modem	2.10 m	None		
9)	Power cable for Printer	1.90 m	None		

**SECTION 6. CONSTRUCTION OF EQUIPMENT**

The construction of EUT during the test was as follows.

**System configuration**

\* : EUT  
 ■ : Ferrite core



Symbols or numbers assigned to equipment or cables on this diagram are corresponded to the symbols or numbers assigned to equipment or cables on tables in Sections 3 to 5.

## SECTION 7. GENERAL TEST CONDITIONS

The EUT was operated under the following conditions during the test.

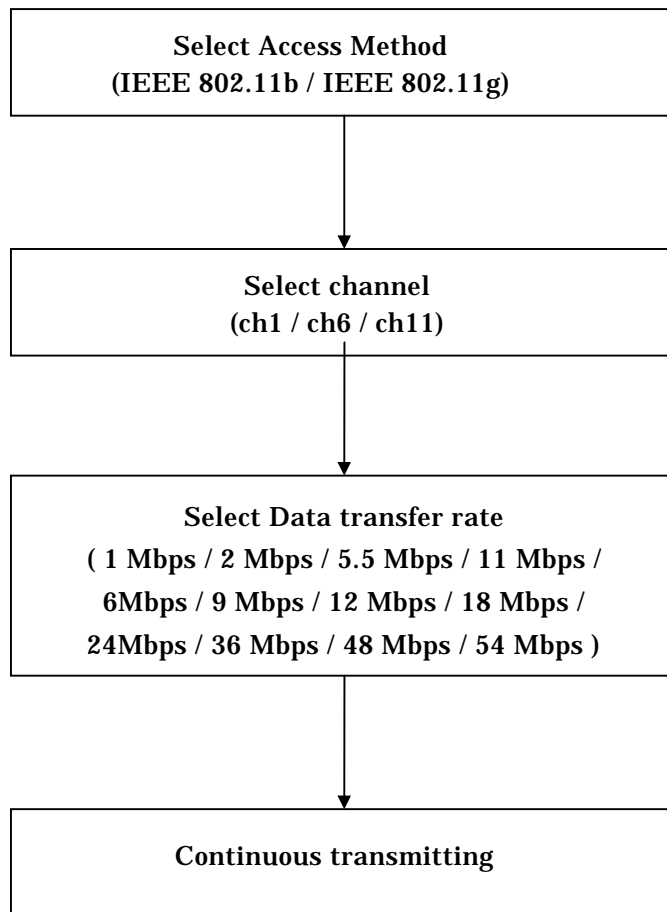
### 7.1 Operating condition

The test was carried out with the transmitter set at maximum power in Test mode. EUT was examined in the operating conditions that had maximum emissions.

### 7.2 Operating flow

Following operations were performed continuously.

#### 7.2.1 Test mode



## SECTION 8. TEST PROCEDURE(S)

Test was carried out under the following conditions.

Test was carried out with no deviations from standards and test methods.

### 8.1 Conducted Emission Test [15.207]

#### 8.1.1 Equipment Setup

System configuration and Equipment setup are shown on Section 6 and Section 10.

##### 8.1.1.1 Table-Top Equipment

EUT is placed on the wooden table raised 0.8meter above the metal ground plane.

##### 8.1.1.2 Interconnecting Cables

Excess part of the interconnecting cables longer than 1 meter are bundled in the center. Cables that hang closer than 40 cm to the ground plane is folded back and forth forming bundle 30 to 40 cm long, hanging approx, in the middle between ground plane and table.

##### 8.1.1.3 AC Power Cable

AC power cable for EUT is connected to one LISN which is placed on the ground plane. The LISN is placed in 80 cm from the nearest part of EUT chassis.

The excess power cable is bundled in the center, or shortened to appropriate length. AC cables except from the EUT are connected second LISN.

#### 8.1.2 Measuring Instruments

Brief description of Measuring Instruments are as follows;

##### 8.1.2.1 Spectrum Analyzer

The Spectrum analyzer is used for preliminary measurement.

##### 8.1.2.2 EMI Test Receiver

The Quasi-peak detector (IF bandwidth : 10 kHz) and average detector (IF bandwidth : 10 kHz) built in test receiver is used for final measurement.

The test receiver is complied with the specification of the CISPR publication 16.

##### 8.1.2.3 LISN

Two 50 $\mu$ H//50 $\Omega$  LISN are used. The chassis of the LISN is bonded to the ground plane by the copper blade.

One LISN is connected to the EUT. Other LISN (2nd LISN) is connected to the support equipment. The signal output of the 2nd LISN is terminated with a 50 $\Omega$  termination.

### 8.1.3 Test Procedure

#### 8.1.3.1 Preliminary Measurement

EUT is tested on all operating conditions.

The spectrum analyzer is controlled by the computer program to sweep the frequency range to be measured, then spectrum chart are plotted out to find the worst emission conditions in operating mode and/or configuration decision for the final test.

All leads other than safety ground are tested.

#### 8.1.3.2 Final Measurement

The EUT is operated in the worst emission condition found by the preliminary test. The equipment and cables are arranged or manipulated within the range of the test standard in the above condition.

At least six highest spectrum are measured in quasi-peak and average (if necessary) using the test receiver.

## **8.2 Radiated Emission Test [15.209]**

### **8.2.1 Equipment Setup**

System configuration and Equipment setup are shown on Section 6 and Section 10.

#### **8.2.1.1 Table-Top Equipment**

EUT is placed on the wooden table raised 0.8meter above the metal ground plane (turntable).

#### **8.2.1.2 Interconnecting Cables**

Excess part of the interconnecting cables longer than 1 meter are bundled in the center. Cables that hang closer than 40 cm to the ground plane is folded back and forth forming bundle 30 to 40 cm long, hanging approx, in the middle between ground plane and table.

### **8.2.2 Measuring Instruments**

Brief description of Measuring Instruments are as follows;

#### **8.2.2.1 Antennas**

The broadband Tri-log antenna is used for measurement on the frequency range 30 – 1000 MHz.

The Double ridged guide antenna and the Standard gain horn antennas are used for frequency higher than 1000 MHz.

If uncertain result was obtained, the broadband antenna is replaced by the half wave length dipole, then measurement is carried out over again.

#### **8.2.2.2 Pre-amplifier**

The broadband pre-amplifier is used for radiated emission measurement.

The signal to noise ratio is improved by using pre-amplifier.

#### **8.2.2.3 Spectrum Analyzer**

The spectrum analyzer is used for preliminary measurement of frequency range 30 – 1000 MHz, and also used for final measurement of higher than 1000 MHz (Resolution bandwidth : 1 MHz).

#### **8.2.2.4 EMI Test Receiver**

The Quasi-peak detector (IF bandwidth : 120 kHz) built in test receiver is used for final measurement of the frequency 30 – 1000 MHz.

The test receiver is complied with the specification of the CISPR publication 16.

#### **8.2.2.5 Turntable**

The turntable is capable for EUT weight and rotatable 0 to 360 degree horizontally by remote control in the test room.

#### **8.2.2.6 Antenna Mast**

The antenna mast is attachable to all antennas described on clause 8.2.2.1 and antenna height is adjustable 1 to 4 meters continuously by remote control at the test room, and antenna polarization is also changed by the remote control.

### 8.2.3 Test Procedure

#### 8.2.3.1 Preliminary Measurement

EUT is tested on all operating conditions.

The spectrum analyzer is set max-hold mode and swept during turntable was rotated 0 to 360 degree. Then spectrum chart are plotted out to detect the worst conditions in configuration, operating mode, or ambient noise notation.

#### 8.2.3.2 Final Measurement

The EUT operated in the condition where maximum emission is detected in the preliminary test.

The turntable azimuth (EUT direction) and antenna height are adjusted the position so that maximum field strength is obtained for each frequency spectrum to be measured. The equipment and cables are arranged or manipulated within the range of the test standard in the above condition.

When the uncertain result was obtained, the measurement is retried by using the half wave dipole antenna instead of the broadband antenna.

**SECTION 9. TEST DATA****9.1 Minimum 6dB Bandwidth [15.247(a)(2)]****MEASUREMENT PROCEDURE:**

1. The EUT was set to operate with following conditions.
  - ch1 / ch6 / ch11
  - All Data Transfer Rate
2. The Spectrum Analyzer was connected directly to the transmitter output.
3. The Spectrum Analyzer was setup using RBW = 100kHz, VBW = 100kHz, and span = 50MHz (span>>RBW).
4. As for the typical chart of the observed RF profiles, refer to page 19 - 21.

Test date : April 11, 2003  
 Temperature : 24 °C  
 Humidity : 44 %

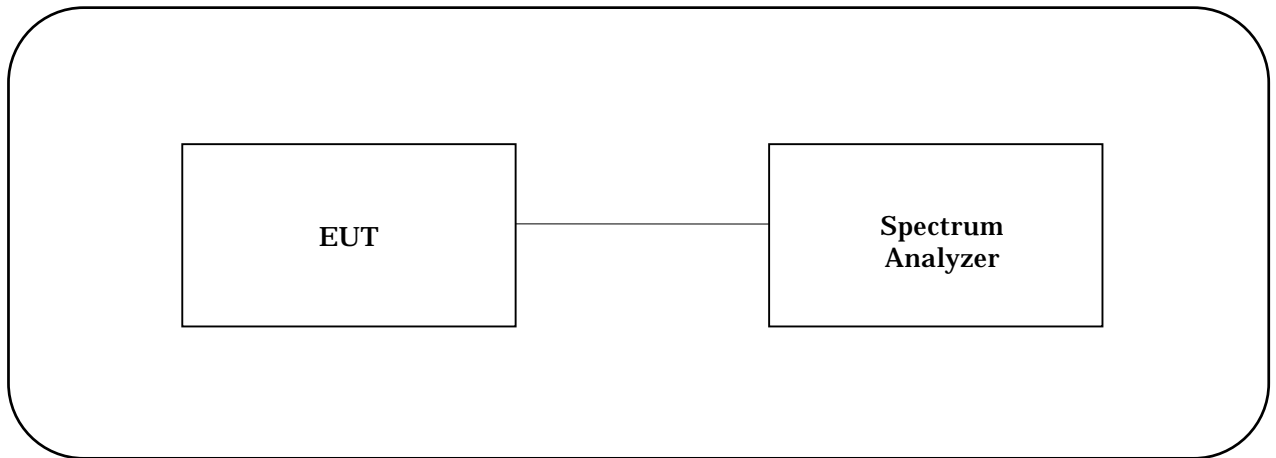
**[Modulation Method : 2.4GHz DS-SS]**

Ch	Frequency (MHz)	Data Transfer Rate (Mbps)	6dB Bandwidth (MHz)	15.247(a)(2) Limit (kHz)	Chart
1	2412	1	12.08	500	Page 19
		2	12.08	500	-
		5.5	12.42	500	-
		11	12.58	500	-
6	2437	1	12.08	500	Page 19
		2	12.50	500	-
		5.5	12.42	500	-
		11	12.25	500	-
11	2462	1	12.08	500	Page 20
		2	12.42	500	-
		5.5	12.25	500	-
		11	12.17	500	-



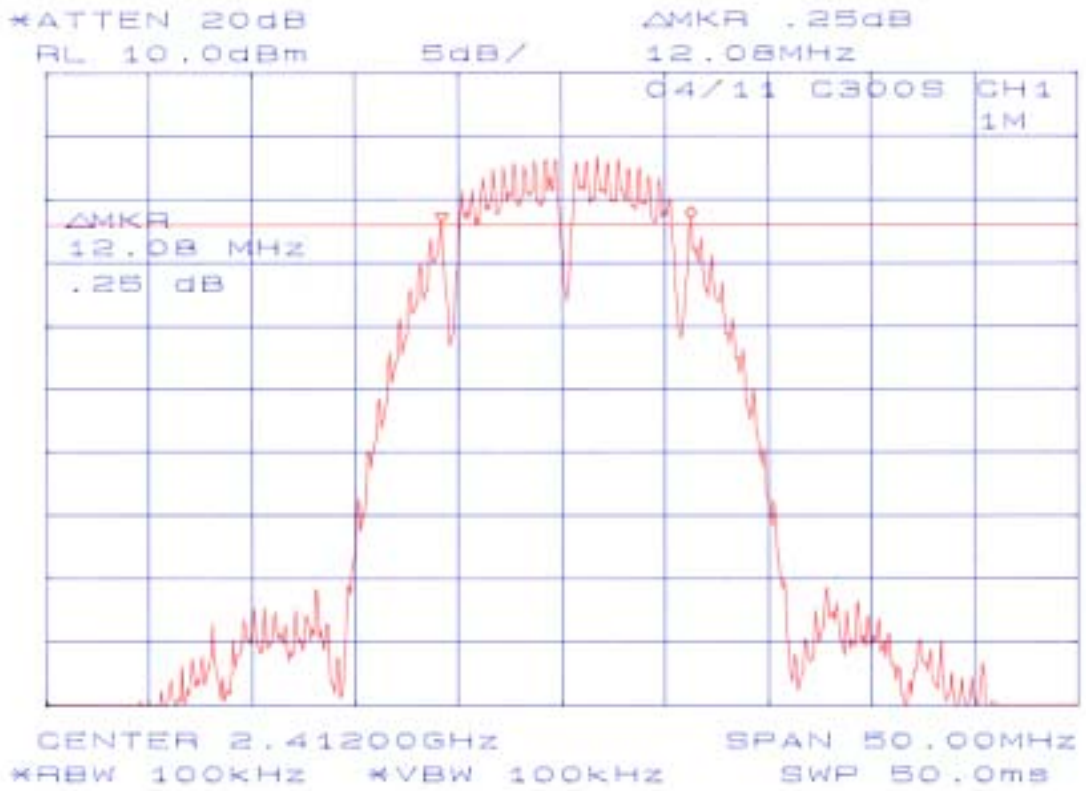
**[Modulation Method : 2.4GHz OFDM]**

<b>Ch</b>	<b>Frequency (MHz)</b>	<b>Data Rate (Mbps)</b>	<b>6dB Bandwidth (MHz)</b>	<b>15.247(a)(2) Limit (kHz)</b>	<b>Chart</b>
<b>1</b>	<b>2412</b>	<b>6</b>	<b>16.67</b>	<b>500</b>	-
		<b>9</b>	<b>16.58</b>	<b>500</b>	<b>Page 20</b>
		<b>12</b>	<b>16.67</b>	<b>500</b>	-
		<b>18</b>	<b>16.67</b>	<b>500</b>	-
		<b>24</b>	<b>16.67</b>	<b>500</b>	-
		<b>36</b>	<b>16.67</b>	<b>500</b>	-
		<b>48</b>	<b>16.67</b>	<b>500</b>	-
		<b>54</b>	<b>16.67</b>	<b>500</b>	-
<b>6</b>	<b>2437</b>	<b>6</b>	<b>16.75</b>	<b>500</b>	-
		<b>9</b>	<b>16.58</b>	<b>500</b>	<b>Page 21</b>
		<b>12</b>	<b>16.75</b>	<b>500</b>	-
		<b>18</b>	<b>16.75</b>	<b>500</b>	-
		<b>24</b>	<b>16.75</b>	<b>500</b>	-
		<b>36</b>	<b>16.75</b>	<b>500</b>	-
		<b>48</b>	<b>16.75</b>	<b>500</b>	-
		<b>54</b>	<b>16.75</b>	<b>500</b>	-
<b>11</b>	<b>2462</b>	<b>6</b>	<b>16.67</b>	<b>500</b>	-
		<b>9</b>	<b>16.67</b>	<b>500</b>	<b>Page 21</b>
		<b>12</b>	<b>16.75</b>	<b>500</b>	-
		<b>18</b>	<b>16.67</b>	<b>500</b>	-
		<b>24</b>	<b>16.75</b>	<b>500</b>	-
		<b>36</b>	<b>16.67</b>	<b>500</b>	-
		<b>48</b>	<b>16.75</b>	<b>500</b>	-
		<b>54</b>	<b>16.75</b>	<b>500</b>	-

**TEST INSTRUMENTS CONFIGURATION****TEST INSTRUMENTS**

<b>Instrument</b>	<b>Model No.</b>	<b>Serial No.</b>	<b>Manufacturer</b>	<b>Last cal. date</b>	<b>Period</b>
Spectrum Analyzer	8564E	3643A00665	HEWLETT PACKARD	Jun. 28, 02	1 Year

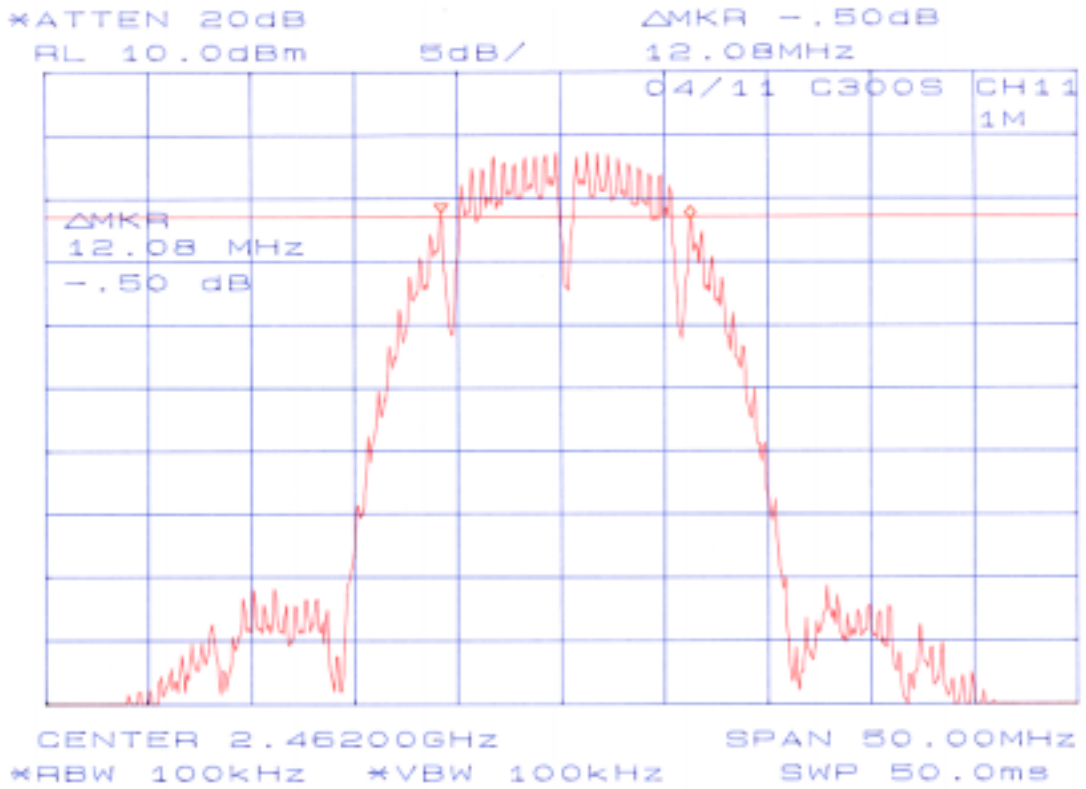
**Chart of ch 1 with 1 Mbps**



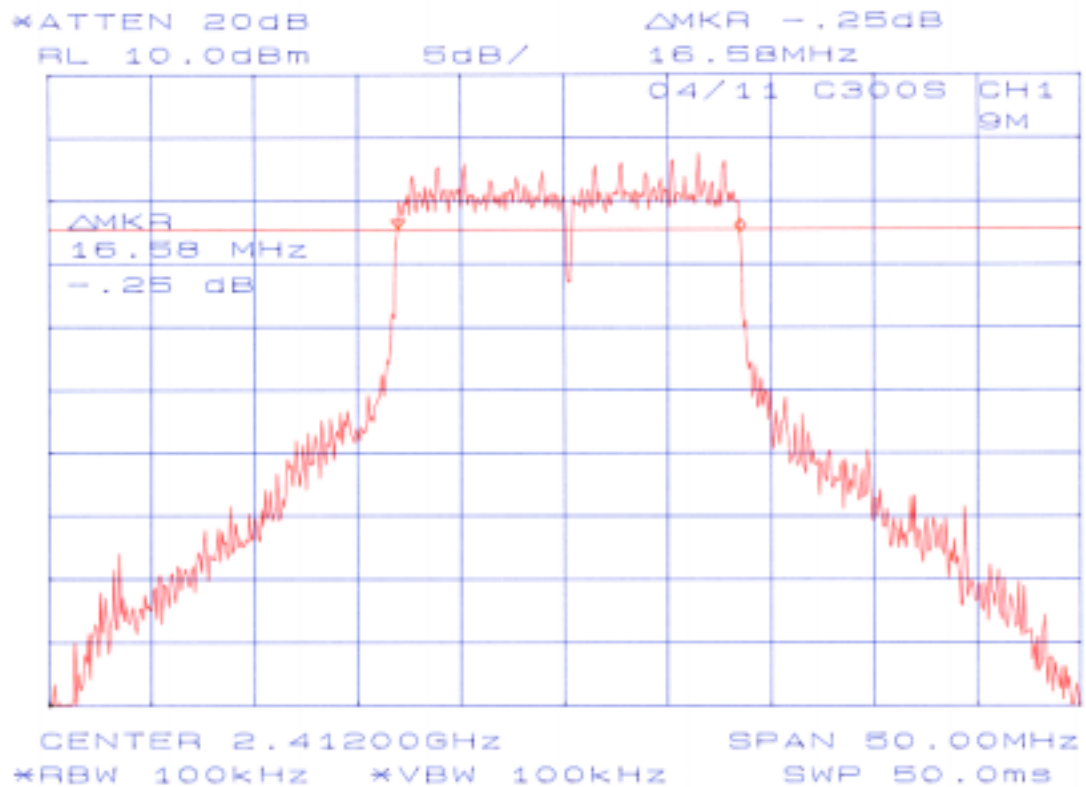
**Chart of ch 6 with 1 Mbps**



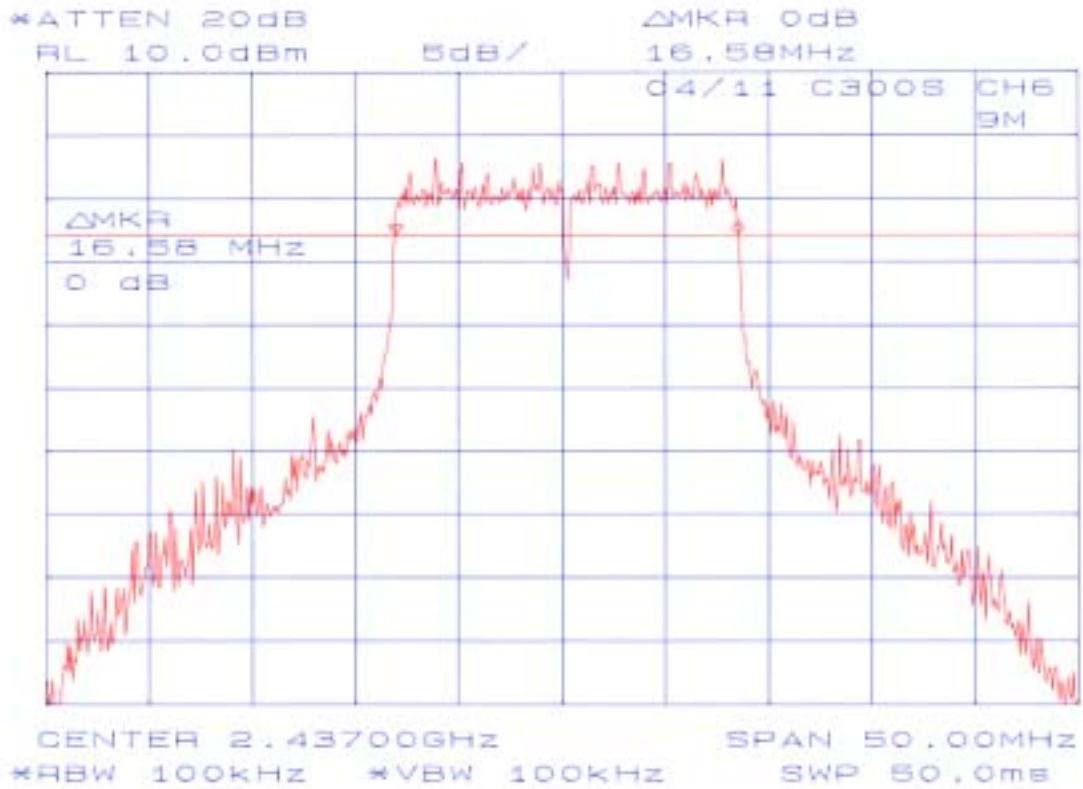
**Chart of ch 11 with 1 Mbps**



**Chart of ch 1 with 9 Mbps**



**Chart of ch 6 with 9 Mbps**



**Chart of ch 11 with 9 Mbps**



**9.2 Maximum Peak Output Power [15.247(b)]****MEASUREMENT PROCEDURE:**

1. The EUT was set to operate with following conditions.
  - ch1 / ch6 / ch11
  - All Data Transfer Rate
2. The power Meter was connected directly to the transmitter output.
3. Maximum Antenna Gain :   Antenna A = 1.16 dBi  
  Antenna B = 1.20 dBi

Test date                               : April 7, 2003  
 Temperature                         : 24 °C  
 Humidity                               : 38 %

**[Modulation Method : 2.4GHz DS-SS]**

Ch	Frequency (MHz)	Data Transfer Rate (Mbps)	Reading (dBm)	Cable Loss (dB)	Maximum Peak Output Power (dBm)	Maximum Peak Output Power (mW)	15.247(b) Limit (mW)
1	2412	1	12.3	0.7	13.0	20.0	1000
		2	12.1	0.7	12.8	19.1	1000
		5.5	12.4	0.7	13.1	20.4	1000
		11	11.6	0.7	12.3	17.0	1000
6	2437	1	12.4	0.7	13.1	20.4	1000
		2	12.3	0.7	13.0	20.0	1000
		5.5	12.3	0.7	13.0	20.0	1000
		11	11.7	0.7	12.4	17.4	1000
11	2462	1	12.3	0.7	13.0	20.0	1000
		2	12.2	0.7	12.9	19.5	1000
		5.5	12.2	0.7	12.9	19.5	1000
		11	11.6	0.7	12.3	17.0	1000

Note: Maximum peak output power was detected at ch 6 with 1Mbps.  
 = 13.1 dBm (=20.4 mW)

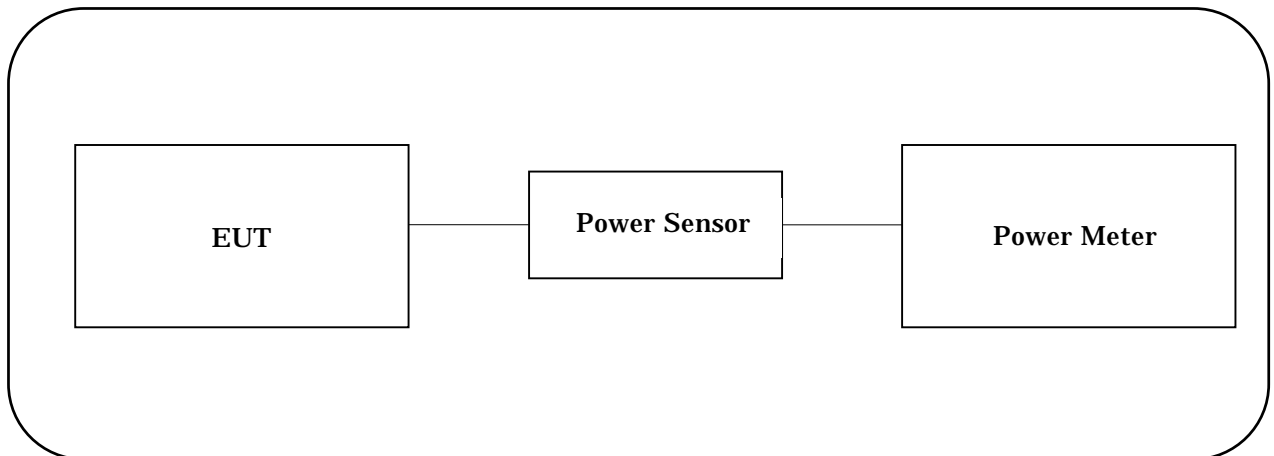
Therefore, the maximum EIRP = 13.1 dBm + 1.2 dBi = 14.3 dBm (=26.9 mW)

**[Modulation Method : 2.4GHz OFDM]**

Ch	Frequency (MHz)	Data Transfer Rate (Mbps)	Reading (dBm)	Cable Loss (dB)	Maximum Peak Output Power (dBm)	Maximum Peak Output Power (mW)	15.247(b) Limit (mW)
1	2412	6	14.1	0.7	14.8	30.2	1000
		9	14.1	0.7	14.8	30.2	1000
		12	14.0	0.7	14.7	29.5	1000
		18	14.0	0.7	14.7	29.5	1000
		24	14.0	0.7	14.7	29.5	1000
		36	11.8	0.7	12.5	17.8	1000
		48	9.4	0.7	10.1	10.2	1000
		54	9.4	0.7	10.1	10.2	1000
6	2437	6	14.2	0.7	14.9	30.9	1000
		9	14.2	0.7	14.9	30.9	1000
		12	14.2	0.7	14.9	30.9	1000
		18	14.1	0.7	14.8	30.2	1000
		24	14.1	0.7	14.8	30.2	1000
		36	11.7	0.7	12.4	17.4	1000
		48	9.4	0.7	10.1	10.2	1000
		54	9.4	0.7	10.1	10.2	1000
11	2462	6	14.2	0.7	14.9	30.9	1000
		9	14.2	0.7	14.9	30.9	1000
		12	14.1	0.7	14.8	30.2	1000
		18	14.0	0.7	14.7	29.5	1000
		24	14.0	0.7	14.7	29.5	1000
		36	11.9	0.7	12.6	18.2	1000
		48	9.8	0.7	10.5	11.2	1000
		54	9.8	0.7	10.5	11.2	1000

Note: Maximum peak output power was detected at ch 6 with 6Mbps.  
= 14.9 dBm (=30.9 mW)

Therefore, the maximum EIRP = 14.9 dBm + 1.2 dBi = 16.1 dBm (=40.7 mW)

**TEST INSTRUMENTS CONFIGURATION****TEST INSTRUMENTS**

<b>Instrument</b>	<b>Model No.</b>	<b>Serial No.</b>	<b>Manufacturer</b>	<b>Last cal. date</b>	<b>Period</b>
Power Meter	438A	2634A03211	HEWLETT PACKARD	Jan. 14, 03	1 Year
Power Sensor	8481A	3318A99780	HEWLETT PACKARD	Jan. 22, 03	1 Year



### 9.3 Power Spectral Density [15.247(d)]

#### MEASUREMENT PROCEDURE:

- The EUT was set to operate with following conditions.
  - ch1 / ch6 / ch11
  - All Data Transfer Rate
- The Spectrum Analyzer was connected directly to the transmitter output.
- The Spectrum Analyzer was setup using RBW = 3kHz, VBW = 10kHz, span = 300kHz and sweep = 100sec.(span/3kHz).
- As for the typical chart of the observed RF profiles, refer to page 28 - 30.

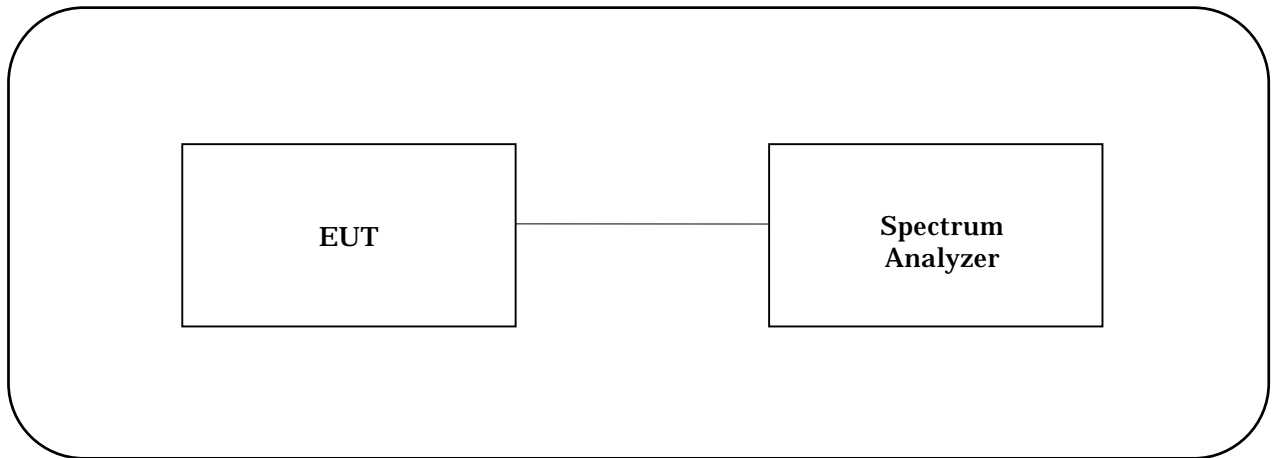
Test date : April 11, 2003  
 Temperature : 24 °C  
 Humidity : 44 %

#### [Modulation Method : 2.4GHz DS-SS]

Ch	Frequency (MHz)	Data Transfer Rate (Mbps)	Reading (dBm)	Cable Loss (dB)	Peak Power Spectral Dencity (dBm)	15.247(d) Limit (dBm)	Chart
1	2412	1	-9.00	0.7	-8.30	8	-
		2	-9.00	0.7	-8.30	8	-
		5.5	-8.67	0.7	-7.97	8	-
		11	-7.33	0.7	-6.63	8	Page 28
6	2437	1	-9.17	0.7	-8.47	8	-
		2	-8.67	0.7	-7.97	8	-
		5.5	-8.33	0.7	-7.63	8	-
		11	-7.33	0.7	-6.63	8	Page 28
11	2462	1	-9.33	0.7	-8.63	8	-
		2	-8.83	0.7	-8.13	8	-
		5.5	-8.50	0.7	-7.80	8	-
		11	-6.33	0.7	-5.63	8	Page 29

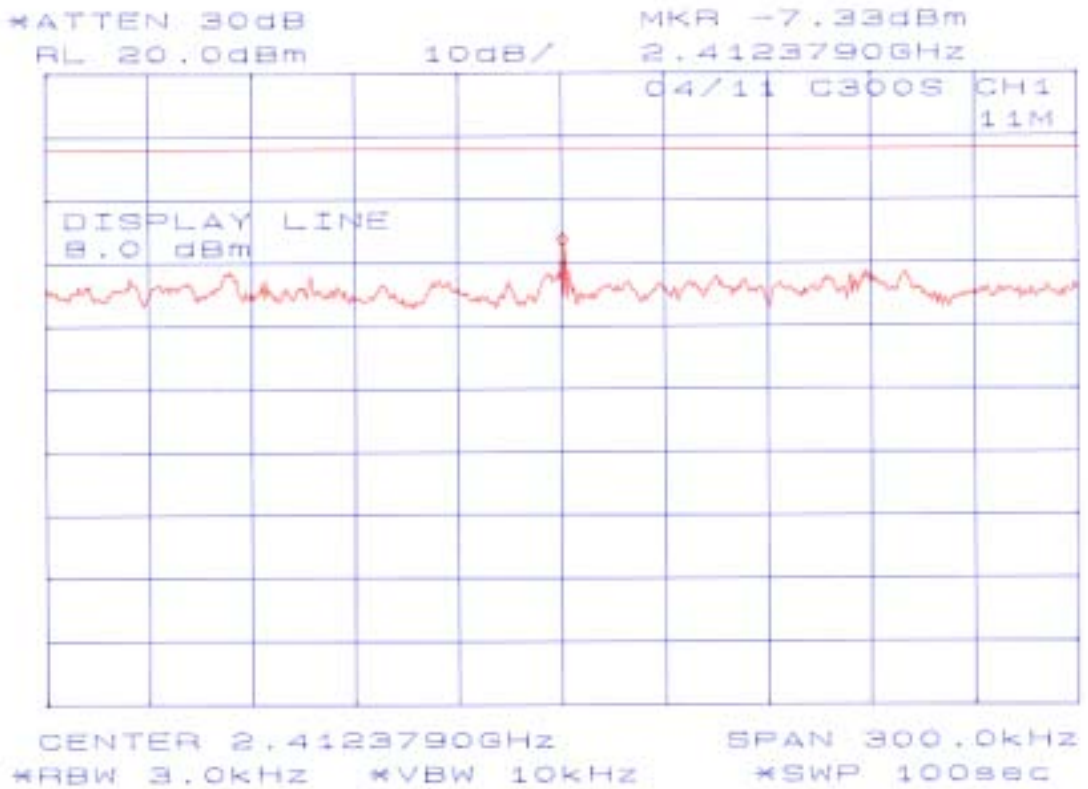
**[Modulation Method : 2.4GHz OFDM]**

Ch	Frequency (MHz)	Data Transfer Rate (Mbps)	Reading (dBm)	Cable Loss (dB)	Peak Power Spectral Dencity (dBm)	15.247(d) Limit (dBm)	Chart
1	2412	6	-9.00	0.7	-8.30	8	-
		9	-8.50	0.7	-7.80	8	-
		12	-8.33	0.7	-7.63	8	Page 29
		18	-9.00	0.7	-8.30	8	-
		24	-9.17	0.7	-8.47	8	-
		36	-11.33	0.7	-10.63	8	-
		48	-13.83	0.7	-13.13	8	-
		54	-13.00	0.7	-12.30	8	-
6	2437	6	-9.17	0.7	-8.47	8	-
		9	-8.50	0.7	-7.80	8	Page 30
		12	-8.83	0.7	-8.13	8	-
		18	-9.33	0.7	-8.63	8	-
		24	-9.17	0.7	-8.47	8	-
		36	-11.67	0.7	-10.97	8	-
		48	-13.50	0.7	-12.80	8	-
		54	-12.33	0.7	-11.63	8	-
11	2462	6	-8.83	0.7	-8.13	8	-
		9	-8.33	0.7	-7.63	8	Page 30
		12	-8.83	0.7	-8.13	8	-
		18	-8.67	0.7	-7.97	8	-
		24	-9.50	0.7	-8.80	8	-
		36	-10.83	0.7	-10.13	8	-
		48	-13.67	0.7	-12.97	8	-
		54	-12.17	0.7	-11.47	8	-

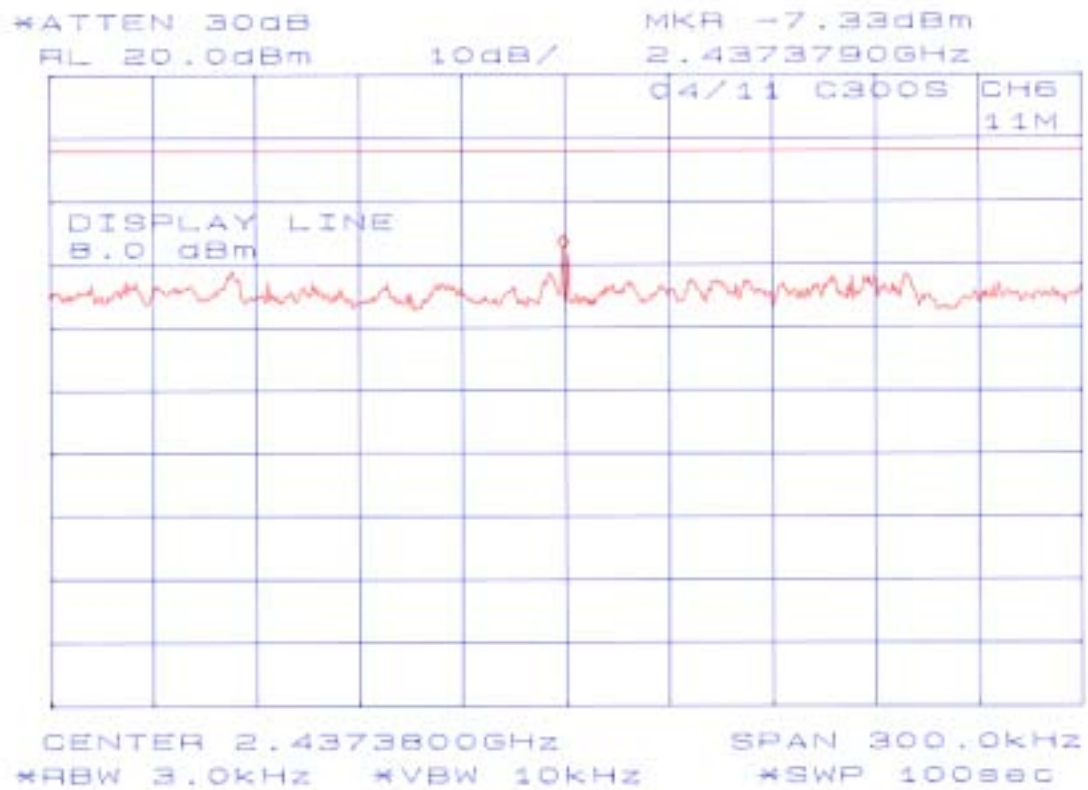
**TEST INSTRUMENTS CONFIGURATION****TEST INSTRUMENTS**

<b>Instrument</b>	<b>Model No.</b>	<b>Serial No.</b>	<b>Manufacturer</b>	<b>Last cal. date</b>	<b>Period</b>
Spectrum Analyzer	8564E	3643A00665	HEWLETT PACKARD	Jun. 28, 02	1 Year

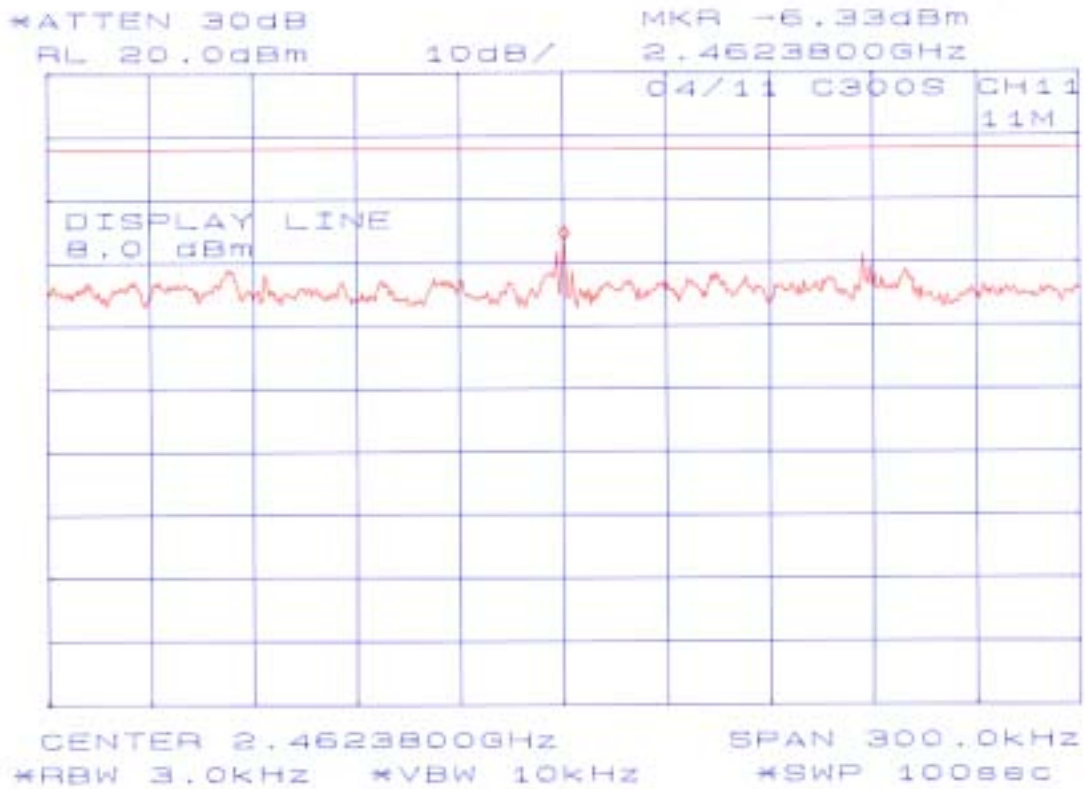
**Chart of ch 1 with 11 Mbps**



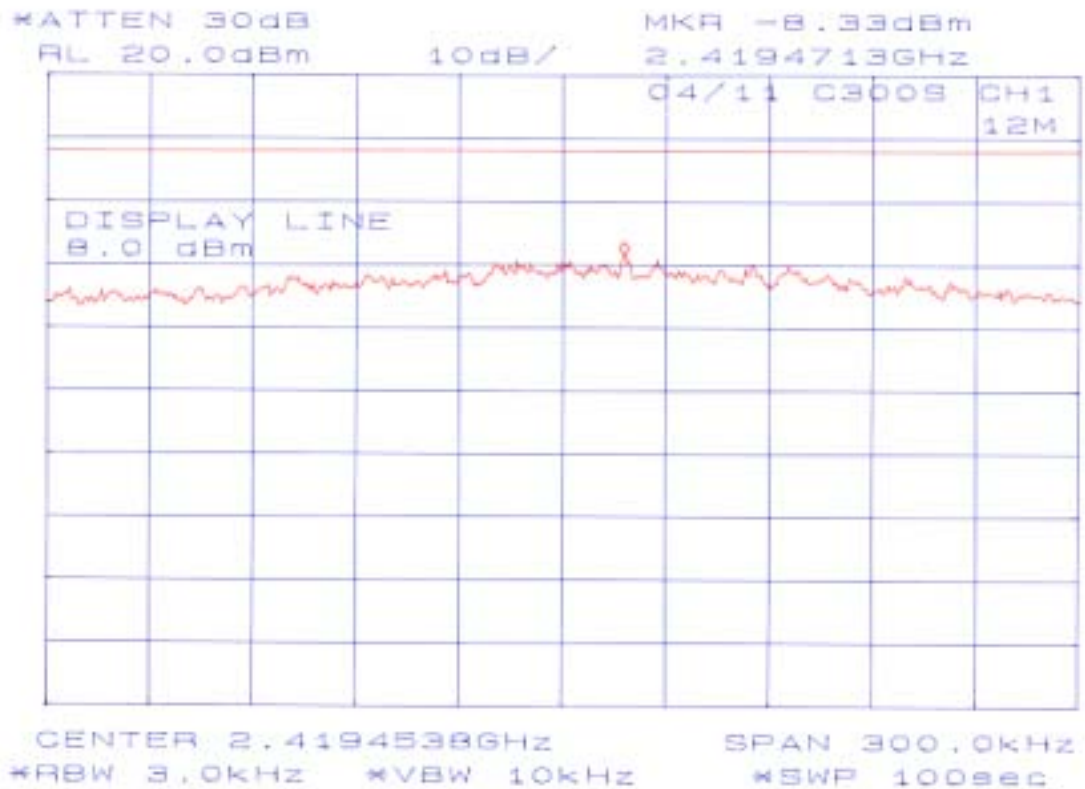
**Chart of ch 6 with 11 Mbps**



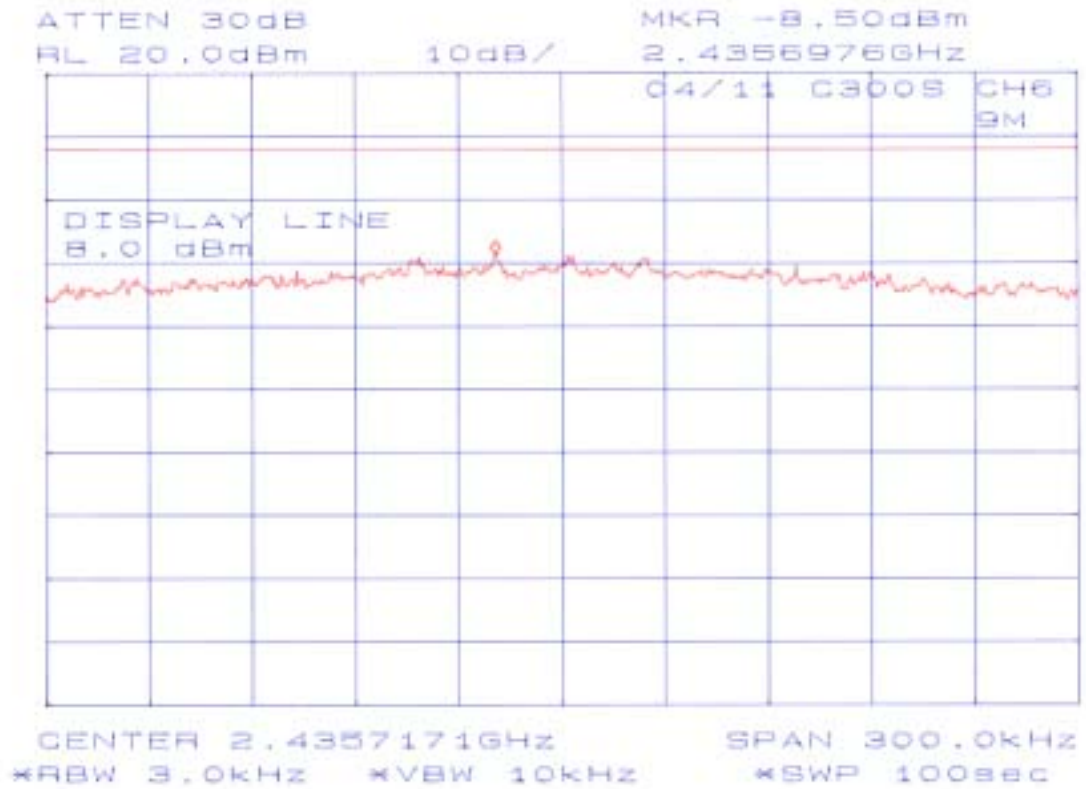
**Chart of ch 11 with 11 Mbps**



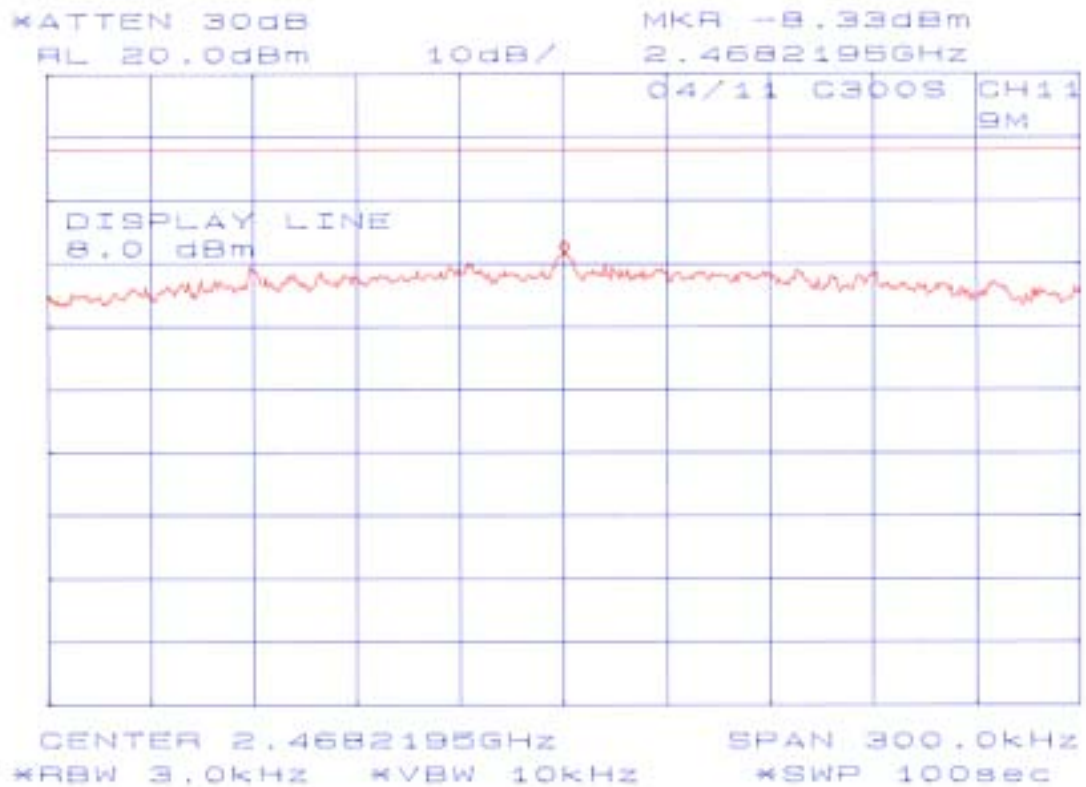
**Chart of ch 1 with 12 Mbps**



**Chart of ch 6 with 9 Mbps**



**Chart of ch 11 with 9 Mbps**



**9.4 Spurious Emissions – RF Antenna Conducted Test [15.247(c)]****MEASUREMENT PROCEDURE:**

1. The EUT was set to operate with following conditions.
  - ch1 / ch6 / ch11
  - All Data Transfer Rate
2. The Spectrum Analyzer was connected directly to the transmitter output.
3. The Spectrum Analyzer was setup using RBW = 100kHz, VBW = 100kHz.
4. As for the typical chart of the observed RF profiles, refer to Annex A and Annex B.

Test date : April 13, 2003  
 Temperature : 24 °C  
 Humidity : 40 %

**[Modulation Method : 2.4GHz DS-SS]**

Ch	Frequency (MHz)	Chart
1	2412	Annex A page 2-5
6	2437	Annex A page 6-9
11	2462	Annex A page 10-13

**Note:**

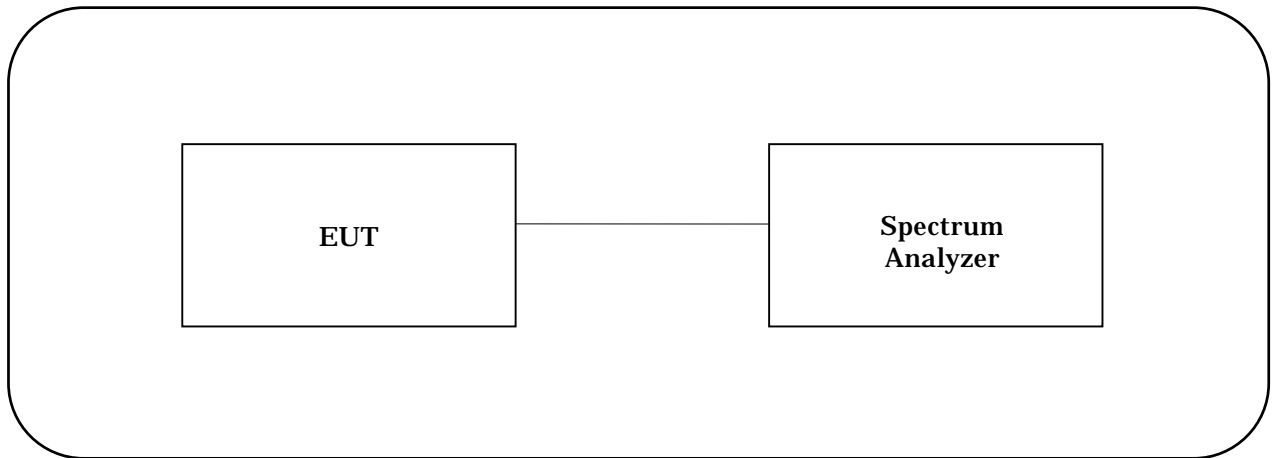
1. All out-of-band conducted emissions were more than 20 dB below a carrier.

**[Modulation Method : 2.4GHz OFDM]**

Ch	Frequency (MHz)	Chart
1	2412	Annex B page 2-5
6	2437	Annex B page 6-9
11	2462	Annex B page 10-13

**Note:**

1. All out-of-band conducted emissions were more than 20 dB below a carrier.

**TEST INSTRUMENTS CONFIGURATION****TEST INSTRUMENTS**

<b>Instrument</b>	<b>Model No.</b>	<b>Serial No.</b>	<b>Manufacturer</b>	<b>Last cal. date</b>	<b>Period</b>
Spectrum Analyzer	8564E	3643A00665	HEWLETT PACKARD	Jun. 28, 02	1 Year



**9.5 Spurious Emissions – Radiated Emission Test [15.247(c), 15.205, 15.209]****MEASUREMENT PROCEDURE:**

1. The EUT was set to operate with following conditions.
  - ch1 / ch6 / ch11
  - All Data Transfer Rate
2. The Spectrum Analyzer was setup using
  - Peak mode: RBW = 1MHz, VBW = 1MHz
  - Average mode: RBW = 1MHz, VBW = 10Hz
3. Following data is the worst case.

**Data of CH1 with 1Mbps in Antenna B (30MHz-1000MHz)**

**Akzo Nobel K. K.**  
**Kashima No.3 Test Site**  
**Radiated Electric Field**

APPLICANT : Sony Corporation  
 EUT NAME : Wireless LAN PC Card  
 MODEL NO. : PCWA-C300S  
 SERIAL NO. : 0000005  
 TEST MODE : TX CH1 1Mbps Ant B  
 POWER SOURCE : AC120V/60Hz  
 DATE TESTED : Apr 08 2003

FILE NO. : ANKK-103108  
 REGULATION : FCC Part15B Class B  
 TEST METHOD : ANSI C63.4-1992  
 DISTANCE : 3.0 [m]  
 TEMPERATURE : 22.0 [degC]  
 HUMIDITY : 43.0 [%]  
 NOTE :

ENGINEER : Yasuhiro Kase

FREQUENCY [No]	[MHz]	READING [dBuV]		FACTOR [dB/m]		EMISSION [dBuV/m]		LIMIT [dBuV/m]	MARGIN [dB]	
		Hori	Vert	Hori	Vert	Hori	Vert		Hori	Vert
1	42.50	-	37.8	-8.9	-8.9	-	28.9	40.0	-	11.1
2	93.17	40.0	-	-12.8	-12.8	27.2	-	43.5	16.3	-
3	132.97	36.8	35.6	-7.8	-7.8	29.0	27.8	43.5	14.5	15.7
4	192.02	34.4	-	-9.5	-9.5	24.9	-	43.5	18.6	-
5	384.00	35.8	-	-2.7	-2.7	33.1	-	46.0	12.9	-
6	512.00	33.5	-	0.9	0.9	34.4	-	46.0	11.6	-
7	528.09	-	34.7	1.3	1.3	-	36.0	46.0	-	10.0
8	577.52	-	32.5	2.9	2.9	-	35.4	46.0	-	10.6
9	933.49	26.5	-	9.6	9.6	36.1	-	46.0	9.9	-

Other frequencies : Below the FCC Part15B Class B limit

Emission Level = Read + Factor(Antenna, Antenna Pad, Cable, Preamp)

ANT. : Used antenna(BBA = Broadband antenna, DIP = Dipole antenna)

**Data of CH11 with 6Mbps in Antenna B (30MHz-1000MHz)**

**Akzo Nobel K. K.**  
**Kashima No.3 Test Site**  
**Radiated Electric Field**

APPLICANT : Sony Corporation  
 EUT NAME : Wireless LAN PC Card  
 MODEL NO. : PCWA-C300S  
 SERIAL NO. : 0000005  
 TEST MODE : TX CH11 6Mbps Ant B  
 POWER SOURCE : AC120V/60Hz  
 DATE TESTED : Apr 10 2003

FILE NO. : ANKK-103108  
 REGULATION : FCC Part15B Class B  
 TEST METHOD : ANSI C63.4-1992  
 DISTANCE : 3.0 [m]  
 TEMPERATURE : 22.0 [degC]  
 HUMIDITY : 43.0 [%]  
 NOTE :

ENGINEER : Yasuhiro Kase

FREQUENCY [No]	[MHz]	READING [dBuV]		FACTOR [dB/m]		EMISSION [dBuV/m]		LIMIT [dBuV/m]	MARGIN [dB]	
		Hori	Vert	Hori	Vert	Hori	Vert		Hori	Vert
1	42.50	-	37.5	-8.9	-8.9	-	28.6	40.0	-	11.4
2	93.17	39.0	-	-12.8	-12.8	26.2	-	43.5	17.3	-
3	133.09	38.0	39.4	-7.8	-7.8	30.2	31.6	43.5	13.3	11.9
4	192.02	35.2	-	-9.5	-9.5	25.7	-	43.5	17.8	-
5	384.00	34.0	-	-2.7	-2.7	31.3	-	46.0	14.7	-
6	512.00	30.0	-	0.9	0.9	30.9	-	46.0	15.1	-
7	528.09	-	31.2	1.3	1.3	-	32.5	46.0	-	13.5
8	577.52	-	31.5	2.9	2.9	-	34.4	46.0	-	11.6
9	931.77	26.3	-	9.5	9.5	35.8	-	46.0	10.2	-

Other frequencies : Below the FCC Part15B Class B limit

Emission Level = Read + Factor(Antenna, Antenna Pad, Cable, Preamp)

ANT. : Used antenna(BBA = Broadband antenna, DIP = Dipole antenna)

**Data of CH1 with 1Mbps in Antenna A (1GHz-40GHz)**

**Akzo Nobel K. K.**  
**Kashima No.3 Test Site**  
**Spurious Emissions**

APPLICANT	: Sony Corporation	FILE NO.	: ANKK-103108
EUT NAME	: Wireless LAN PC Card	REGULATION	: FCC 15.247(c), 15.209
MODEL NO.	: PCWA-C300S	TEST METHOD	: ANSI C63.4:1992
SERIAL NO.	: 0000005	DISTANCE	: 1.0 [m]
TEST MODE	: TX CH1 1Mbps Ant A	TEMPERATURE	: 22.0 [degC]
POWER SOURCE	: AC120V/60Hz	HUMIDITY	: 43.0 [%]
DATE TESTED	: Apr 08 2003	NOTE	:

ENGINEER : Yasuhiro Kase

FREQUENCY [No]	MODE [MHz]		READING [dBuV]		FACTOR [dB]		EMISSION [dBuV/m]		LIMIT [dBuV/m]	MARGIN [dB]	
			Hori	Vert	Hori	Vert	Hori	Vert		Hori	Vert
1	4823.95	PEK	53.5	49.5	-4.0	-4.0	49.5	45.5	74.0	24.5	28.5
2	4823.95	AVG	51.9	47.3	-4.0	-4.0	47.9	43.3	54.0	6.1	10.7
3	7238.69	PEK	41.4	41.0	2.2	2.2	43.6	43.2	74.0	30.4	30.8
4	7238.69	AVG	31.1	31.8	2.2	2.2	33.3	34.0	54.0	20.7	20.0
5	9647.82	PEK	42.3	43.3	7.1	7.1	49.4	50.4	74.0	24.6	23.6
6	9647.82	AVG	37.1	39.0	7.1	7.1	44.2	46.1	54.0	9.8	7.9
7	12058.50	PEK	36.8	36.8	7.3	7.3	44.1	44.1	74.0	29.9	29.9
8	12058.50	AVG	24.5	24.3	7.3	7.3	31.8	31.6	54.0	22.2	22.4

Other frequencies : Below the FCC 15.247(c), 15.209 limit

Emission Level = Read + Factor(Antenna,Antenna Pad,Cable,Preamp)

**Data of CH1 with 1Mbps in Antenna B (1GHz-40GHz)**

**Akzo Nobel K. K.**  
**Kashima No.3 Test Site**  
**Spurious Emissions**

APPLICANT	: Sony Corporation	FILE NO.	: ANKK-103108
EUT NAME	: Wireless LAN PC Card	REGULATION	: FCC 15.247(c), 15.209
MODEL NO.	: PCWA-C300S	TEST METHOD	: ANSI C63.4:1992
SERIAL NO.	: 0000005	DISTANCE	: 1.0 [m]
TEST MODE	: TX CH1 1Mbps Ant B	TEMPERATURE	: 22.0 [degC]
POWER SOURCE	: AC120V/60Hz	HUMIDITY	: 43.0 [%]
DATE TESTED	: Apr 08 2003	NOTE	:

ENGINEER : Yasuhiro Kase

FREQUENCY [No]	MODE [MHz]		READING [dBuV]		FACTOR [dB]		EMISSION [dBuV/m]		LIMIT [dBuV/m]	MARGIN [dB]	
			Hori	Vert	Hori	Vert	Hori	Vert		Hori	Vert
1	4823.95	PEK	48.0	46.8	-4.0	-4.0	44.0	42.8	74.0	30.0	31.2
2	4823.95	AVG	44.8	42.6	-4.0	-4.0	40.8	38.6	54.0	13.2	15.4
3	7238.69	PEK	40.8	41.7	2.2	2.2	43.0	43.9	74.0	31.0	30.1
4	7238.69	AVG	32.7	32.3	2.2	2.2	34.9	34.5	54.0	19.1	19.5
5	9647.82	PEK	43.1	42.4	7.1	7.1	50.2	49.5	74.0	23.8	24.5
6	9647.82	AVG	38.4	37.6	7.1	7.1	45.5	44.7	54.0	8.5	9.3
7	12058.50	PEK	36.0	35.8	7.3	7.3	43.3	43.1	74.0	30.7	30.9
8	12058.50	AVG	24.6	24.3	7.3	7.3	31.9	31.6	54.0	22.1	22.4

Other frequencies : Below the FCC 15.247(c), 15.209 limit

Emission Level = Read + Factor(Antenna,Antenna Pad,Cable,Preamp)

**Data of CH6 with 1Mbps in Antenna A (1GHz-40GHz)**

**Akzo Nobel K. K.**  
**Kashima No.3 Test Site**  
**Spurious Emissions**

APPLICANT	: Sony Corporation	FILE NO.	: ANKK-103108
EUT NAME	: Wireless LAN PC Card	REGULATION	: FCC 15.247(c), 15.209
MODEL NO.	: PCWA-C300S	TEST METHOD	: ANSI C63.4:1992
SERIAL NO.	: 0000005	DISTANCE	: 1.0 [m]
TEST MODE	: TX CH6 1Mbps Ant A	TEMPERATURE	: 22.0 [degC]
POWER SOURCE	: AC120V/60Hz	HUMIDITY	: 43.0 [%]
DATE TESTED	: Apr 08 2003	NOTE	:

ENGINEER : Yasuhiro Kase

FREQUENCY [No]	MODE [MHz]		READING [dBuV]		FACTOR [dB]		EMISSION [dBuV/m]		LIMIT [dBuV/m]	MARGIN [dB]	
			Hori	Vert	Hori	Vert	Hori	Vert		Hori	Vert
1	4873.97	PEK	53.3	50.6	-3.9	-3.9	49.4	46.7	74.0	24.6	27.3
2	4873.97	AVG	50.0	47.7	-3.9	-3.9	46.1	43.8	54.0	7.9	10.2
3	7308.30	PEK	35.7	39.9	2.2	2.2	37.9	42.1	74.0	36.1	31.9
4	7308.30	AVG	28.6	29.5	2.2	2.2	30.8	31.7	54.0	23.2	22.3
5	9747.88	PEK	40.2	40.0	7.1	7.1	47.3	47.1	74.0	26.7	26.9
6	9747.88	AVG	32.6	32.6	7.1	7.1	39.7	39.7	54.0	14.3	14.3
7	12188.50	PEK	37.0	36.2	7.2	7.2	44.2	43.4	74.0	29.8	30.6
8	12188.50	AVG	24.7	24.0	7.2	7.2	31.9	31.2	54.0	22.1	22.8

Other frequencies : Below the FCC 15.247(c), 15.209 limit

Emission Level = Read + Factor(Antenna,Antenna Pad,Cable,Preamp)

**Data of CH6 with 1Mbps in Antenna B (1GHz-40GHz)**

**Akzo Nobel K. K.**  
**Kashima No.3 Test Site**  
**Spurious Emissions**

APPLICANT	: Sony Corporation	FILE NO.	: ANKK-103108
EUT NAME	: Wireless LAN PC Card	REGULATION	: FCC 15.247(c), 15.209
MODEL NO.	: PCWA-C300S	TEST METHOD	: ANSI C63.4:1992
SERIAL NO.	: 0000005	DISTANCE	: 1.0 [m]
TEST MODE	: TX CH6 1Mbps Ant B	TEMPERATURE	: 22.0 [degC]
POWER SOURCE	: AC120V/60Hz	HUMIDITY	: 43.0 [%]
DATE TESTED	: Apr 08 2003	NOTE	:

ENGINEER : Yasuhiro Kase

FREQUENCY [No]	MODE [MHz]		READING [dBuV]		FACTOR [dB]		EMISSION [dBuV/m]		LIMIT [dBuV/m]	MARGIN [dB]	
			Hori	Vert	Hori	Vert	Hori	Vert		Hori	Vert
1	4873.97	PEK	49.5	48.5	-3.9	-3.9	45.6	44.6	74.0	28.4	29.4
2	4873.97	AVG	44.9	45.3	-3.9	-3.9	41.0	41.4	54.0	13.0	12.6
3	7308.30	PEK	39.4	48.3	2.2	2.2	41.6	50.5	74.0	32.4	23.5
4	7308.30	AVG	34.0	35.9	2.2	2.2	36.2	38.1	54.0	17.8	15.9
5	9747.88	PEK	39.3	44.3	7.1	7.1	46.4	51.4	74.0	27.6	22.6
6	9747.88	AVG	33.3	40.3	7.1	7.1	40.4	47.4	54.0	13.6	6.6
7	12188.50	PEK	37.0	36.0	7.2	7.2	44.2	43.2	74.0	29.8	30.8
8	12188.50	AVG	24.5	25.0	7.2	7.2	31.7	32.2	54.0	22.3	21.8

Other frequencies : Below the FCC 15.247(c), 15.209 limit

Emission Level = Read + Factor(Antenna,Antenna Pad,Cable,Preamp)

**Data of CH11 with 1Mbps in Antenna A (1GHz-40GHz)**

**Akzo Nobel K. K.**  
**Kashima No.3 Test Site**  
**Spurious Emissions**

APPLICANT	: Sony Corporation	FILE NO.	: ANKK-103108
EUT NAME	: Wireless LAN PC Card	REGULATION	: FCC 15.247(c), 15.209
MODEL NO.	: PCWA-C300S	TEST METHOD	: ANSI C63.4:1992
SERIAL NO.	: 0000005	DISTANCE	: 1.0 [m]
TEST MODE	: TX CH11 1Mbps Ant A	TEMPERATURE	: 22.0 [degC]
POWER SOURCE	: AC120V/60Hz	HUMIDITY	: 43.0 [%]
DATE TESTED	: Apr 08 2003	NOTE	:

ENGINEER : Yasuhiro Kase

FREQUENCY [No]	MODE [MHz]		READING [dBuV]		FACTOR [dB]		EMISSION [dBuV/m]		LIMIT [dBuV/m]	MARGIN [dB]	
			Hori	Vert	Hori	Vert	Hori	Vert		Hori	Vert
1	4923.82	PEK	50.8	53.3	-3.8	-3.8	47.0	49.5	74.0	27.0	24.5
2	4923.82	AVG	49.1	51.4	-3.8	-3.8	45.3	47.6	54.0	8.7	6.4
3	7388.50	PEK	37.0	38.9	2.3	2.3	39.3	41.2	74.0	34.7	32.8
4	7388.50	AVG	25.5	28.0	2.3	2.3	27.8	30.3	54.0	26.2	23.7
5	9847.90	PEK	37.5	37.3	7.2	7.2	44.7	44.5	74.0	29.3	29.5
6	9847.90	AVG	26.3	26.5	7.2	7.2	33.5	33.7	54.0	20.5	20.3
7	12317.70	PEK	37.3	37.3	7.2	7.2	44.5	44.5	74.0	29.5	29.5
8	12317.70	AVG	25.0	24.8	7.2	7.2	32.2	32.0	54.0	21.8	22.0

Other frequencies : Below the FCC 15.247(c), 15.209 limit

Emission Level = Read + Factor(Antenna,Antenna Pad,Cable,Preamp)



**Data of CH11 with 1Mbps in Antenna B (1GHz-40GHz)**

**Akzo Nobel K. K.**  
**Kashima No.3 Test Site**  
**Spurious Emissions**

APPLICANT	: Sony Corporation	FILE NO.	: ANKK-103108
EUT NAME	: Wireless LAN PC Card	REGULATION	: FCC 15.247(c), 15.209
MODEL NO.	: PCWA-C300S	TEST METHOD	: ANSI C63.4:1992
SERIAL NO.	: 0000005	DISTANCE	: 1.0 [m]
TEST MODE	: TX CH11 1Mbps Ant B	TEMPERATURE	: 22.0 [degC]
POWER SOURCE	: AC120V/60Hz	HUMIDITY	: 43.0 [%]
DATE TESTED	: Apr 08 2003	NOTE	:

ENGINEER : Yasuhiro Kase

FREQUENCY [No]	MODE [MHz]		READING [dBuV]		FACTOR [dB]		EMISSION [dBuV/m]		LIMIT [dBuV/m]	MARGIN [dB]	
			Hori	Vert	Hori	Vert	Hori	Vert		Hori	Vert
1	4923.82	PEK	50.9	53.8	-3.8	-3.8	47.1	50.0	74.0	26.9	24.0
2	4923.82	AVG	48.8	52.1	-3.8	-3.8	45.0	48.3	54.0	9.0	5.7
3	7388.50	PEK	43.7	43.7	2.3	2.3	46.0	46.0	74.0	28.0	28.0
4	7388.50	AVG	36.6	36.0	2.3	2.3	38.9	38.3	54.0	15.1	15.7
5	9847.90	PEK	42.3	41.1	7.2	7.2	49.5	48.3	74.0	24.5	25.7
6	9847.90	AVG	38.3	34.9	7.2	7.2	45.5	42.1	54.0	8.5	11.9
7	12317.70	PEK	37.6	37.8	7.2	7.2	44.8	45.0	74.0	29.2	29.0
8	12317.70	AVG	25.7	25.2	7.2	7.2	32.9	32.4	54.0	21.1	21.6

Other frequencies : Below the FCC 15.247(c), 15.209 limit

Emission Level = Read + Factor(Antenna,Antenna Pad,Cable,Preamp)

**Data of CH1 with 6Mbps in Antenna A (1GHz-40GHz)**

**Akzo Nobel K. K.**  
**Kashima No.3 Test Site**  
**Spurious Emissions**

APPLICANT	: Sony Corporation	FILE NO.	: ANKK-103108
EUT NAME	: Wireless LAN PC Card	REGULATION	: FCC 15.247(c), 15.209
MODEL NO.	: PCWA-C300S	TEST METHOD	: ANSI C63.4:1992
SERIAL NO.	: 0000005	DISTANCE	: 1.0 [m]
TEST MODE	: TX CH1 6Mbps Ant A	TEMPERATURE	: 22.0 [degC]
POWER SOURCE	: AC120V/60Hz	HUMIDITY	: 43.0 [%]
DATE TESTED	: Apr 08 2003	NOTE	:

ENGINEER : Yasuhiro Kase

FREQUENCY [No]	MODE [MHz]		READING [dBuV]		FACTOR [dB]		EMISSION [dBuV/m]		LIMIT [dBuV/m]	MARGIN [dB]	
			Hori	Vert	Hori	Vert	Hori	Vert		Hori	Vert
1	4803.09	PEK	61.3	57.3	-4.0	-4.0	57.3	53.3	74.0	16.7	20.7
2	4803.09	AVG	44.1	40.8	-4.0	-4.0	40.1	36.8	54.0	13.9	17.2
3	7235.18	PEK	45.5	46.8	2.2	2.2	47.7	49.0	74.0	26.3	25.0
4	7235.18	AVG	32.5	32.7	2.2	2.2	34.7	34.9	54.0	19.3	19.1
5	9644.70	PEK	45.2	49.0	7.1	7.1	52.3	56.1	74.0	21.7	17.9
6	9644.70	AVG	33.0	34.4	7.1	7.1	40.1	41.5	54.0	13.9	12.5
7	12054.76	PEK	37.3	37.8	7.3	7.3	44.6	45.1	74.0	29.4	28.9
8	12054.76	AVG	24.5	24.8	7.3	7.3	31.8	32.1	54.0	22.2	21.9

Other frequencies : Below the FCC 15.247(c), 15.209 limit

Emission Level = Read + Factor(Antenna,Antenna Pad,Cable,Preamp)

**Data of CH1 with 6Mbps in Antenna B (1GHz-40GHz)**

**Akzo Nobel K. K.**  
**Kashima No.3 Test Site**  
**Spurious Emissions**

APPLICANT	: Sony Corporation	FILE NO.	: ANKK-103108
EUT NAME	: Wireless LAN PC Card	REGULATION	: FCC 15.247(c), 15.209
MODEL NO.	: PCWA-C300S	TEST METHOD	: ANSI C63.4:1992
SERIAL NO.	: 0000005	DISTANCE	: 1.0 [m]
TEST MODE	: TX CH1 6Mbps Ant B	TEMPERATURE	: 22.0 [degC]
POWER SOURCE	: AC120V/60Hz	HUMIDITY	: 43.0 [%]
DATE TESTED	: Apr 08 2003	NOTE	:

ENGINEER : Yasuhiro Kase

FREQUENCY [No]	MODE [MHz]		READING [dBuV]		FACTOR [dB]		EMISSION [dBuV/m]		LIMIT [dBuV/m]	MARGIN [dB]	
			Hori	Vert	Hori	Vert	Hori	Vert		Hori	Vert
1	4803.09	PEK	53.2	51.3	-4.0	-4.0	49.2	47.3	74.0	24.8	26.7
2	4803.09	AVG	38.3	36.8	-4.0	-4.0	34.3	32.8	54.0	19.7	21.2
3	7235.18	PEK	52.5	50.8	2.2	2.2	54.7	53.0	74.0	19.3	21.0
4	7235.18	AVG	37.0	35.9	2.2	2.2	39.2	38.1	54.0	14.8	15.9
5	9644.70	PEK	46.4	46.3	7.1	7.1	53.5	53.4	74.0	20.5	20.6
6	9644.70	AVG	32.0	31.9	7.1	7.1	39.1	39.0	54.0	14.9	15.0
7	12054.76	PEK	40.5	37.5	7.3	7.3	47.8	44.8	74.0	26.2	29.2
8	12054.76	AVG	26.6	25.1	7.3	7.3	33.9	32.4	54.0	20.1	21.6

Other frequencies : Below the FCC 15.247(c), 15.209 limit

Emission Level = Read + Factor(Antenna,Antenna Pad,Cable,Preamp)

**Data of CH6 with 6Mbps in Antenna A (1GHz-40GHz)**

**Akzo Nobel K. K.**  
**Kashima No.3 Test Site**  
**Spurious Emissions**

APPLICANT	: Sony Corporation	FILE NO.	: ANKK-103108
EUT NAME	: Wireless LAN PC Card	REGULATION	: FCC 15.247(c), 15.209
MODEL NO.	: PCWA-C300S	TEST METHOD	: ANSI C63.4:1992
SERIAL NO.	: 0000005	DISTANCE	: 1.0 [m]
TEST MODE	: TX CH6 6Mbps Ant A	TEMPERATURE	: 22.0 [degC]
POWER SOURCE	: AC120V/60Hz	HUMIDITY	: 43.0 [%]
DATE TESTED	: Apr 08 2003	NOTE	:

ENGINEER : Yasuhiro Kase

FREQUENCY [No]	MODE [MHz]		READING [dBuV]		FACTOR [dB]		EMISSION [dBuV/m]		LIMIT [dBuV/m]	MARGIN [dB]	
			Hori	Vert	Hori	Vert	Hori	Vert		Hori	Vert
1	4874.08	PEK	56.8	56.7	-3.9	-3.9	52.9	52.8	74.0	21.1	21.2
2	4874.08	AVG	41.9	41.5	-3.9	-3.9	38.0	37.6	54.0	16.0	16.4
3	7309.20	PEK	44.7	43.3	2.2	2.2	46.9	45.5	74.0	27.1	28.5
4	7309.20	AVG	31.3	30.5	2.2	2.2	33.5	32.7	54.0	20.5	21.3
5	9743.58	PEK	43.7	44.3	7.1	7.1	50.8	51.4	74.0	23.2	22.6
6	9743.58	AVG	29.3	29.0	7.1	7.1	36.4	36.1	54.0	17.6	17.9
7	12188.50	PEK	36.3	37.0	7.2	7.2	43.5	44.2	74.0	30.5	29.8
8	12188.50	AVG	23.9	24.0	7.2	7.2	31.1	31.2	54.0	22.9	22.8

Other frequencies : Below the FCC 15.247(c), 15.209 limit

Emission Level = Read + Factor(Antenna,Antenna Pad,Cable,Preamp)

**Data of CH6 with 6Mbps in Antenna B (1GHz-40GHz)**

**Akzo Nobel K. K.**  
**Kashima No.3 Test Site**  
**Spurious Emissions**

APPLICANT	: Sony Corporation	FILE NO.	: ANKK-103108
EUT NAME	: Wireless LAN PC Card	REGULATION	: FCC 15.247(c), 15.209
MODEL NO.	: PCWA-C300S	TEST METHOD	: ANSI C63.4:1992
SERIAL NO.	: 0000005	DISTANCE	: 1.0 [m]
TEST MODE	: TX CH6 6Mbps Ant B	TEMPERATURE	: 22.0 [degC]
POWER SOURCE	: AC120V/60Hz	HUMIDITY	: 43.0 [%]
DATE TESTED	: Apr 08 2003	NOTE	:

ENGINEER : Yasuhiro Kase

FREQUENCY [No]	MODE [MHz]		READING [dBuV]		FACTOR [dB]		EMISSION [dBuV/m]		LIMIT [dBuV/m]	MARGIN [dB]	
			Hori	Vert	Hori	Vert	Hori	Vert		Hori	Vert
1	4874.08	PEK	54.7	54.4	-3.9	-3.9	50.8	50.5	74.0	23.2	23.5
2	4874.08	AVG	38.9	39.0	-3.9	-3.9	35.0	35.1	54.0	19.0	18.9
3	7309.20	PEK	53.8	53.3	2.2	2.2	56.0	55.5	74.0	18.0	18.5
4	7309.20	AVG	39.1	38.3	2.2	2.2	41.3	40.5	54.0	12.7	13.5
5	9743.58	PEK	48.8	45.8	7.1	7.1	55.9	52.9	74.0	18.1	21.1
6	9743.58	AVG	34.0	31.8	7.1	7.1	41.1	38.9	54.0	12.9	15.1
7	12188.50	PEK	37.8	37.7	7.2	7.2	45.0	44.9	74.0	29.0	29.1
8	12188.50	AVG	25.2	24.3	7.2	7.2	32.4	31.5	54.0	21.6	22.5

Other frequencies : Below the FCC 15.247(c), 15.209 limit

Emission Level = Read + Factor(Antenna,Antenna Pad,Cable,Preamp)

**Data of CH11 with 6Mbps in Antenna A (1GHz-40GHz)**

**Akzo Nobel K. K.**  
**Kashima No.3 Test Site**  
**Spurious Emissions**

APPLICANT	: Sony Corporation	FILE NO.	: ANKK-103108
EUT NAME	: Wireless LAN PC Card	REGULATION	: FCC 15.247(c), 15.209
MODEL NO.	: PCWA-C300S	TEST METHOD	: ANSI C63.4:1992
SERIAL NO.	: 0000005	DISTANCE	: 1.0 [m]
TEST MODE	: TX CH11 6Mbps Ant A	TEMPERATURE	: 22.0 [degC]
POWER SOURCE	: AC120V/60Hz	HUMIDITY	: 43.0 [%]
DATE TESTED	: Apr 08 2003	NOTE	:

ENGINEER : Yasuhiro Kase

FREQUENCY [No]	MODE [MHz]		READING [dBuV]		FACTOR [dB]		EMISSION [dBuV/m]		LIMIT [dBuV/m]	MARGIN [dB]	
			Hori	Vert	Hori	Vert	Hori	Vert		Hori	Vert
1	4919.75	PEK	59.3	59.3	-3.8	-3.8	55.5	55.5	74.0	18.5	18.5
2	4919.75	AVG	41.9	42.3	-3.8	-3.8	38.1	38.5	54.0	15.9	15.5
3	7384.40	PEK	43.4	41.0	2.3	2.3	45.7	43.3	74.0	28.3	30.7
4	7384.40	AVG	28.7	28.1	2.3	2.3	31.0	30.4	54.0	23.0	23.6
5	9839.17	PEK	38.8	37.8	7.2	7.2	46.0	45.0	74.0	28.0	29.0
6	9839.17	AVG	25.8	25.3	7.2	7.2	33.0	32.5	54.0	21.0	21.5
7	12306.15	PEK	36.0	37.8	7.2	7.2	43.2	45.0	74.0	30.8	29.0
8	12306.15	AVG	24.9	25.1	7.2	7.2	32.1	32.3	54.0	21.9	21.7

Other frequencies : Below the FCC 15.247(c), 15.209 limit

Emission Level = Read + Factor(Antenna,Antenna Pad,Cable,Preamp)

**Data of CH11 with 6Mbps in Antenna B (1GHz-40GHz)**

**Akzo Nobel K. K.**  
**Kashima No.3 Test Site**  
**Spurious Emissions**

APPLICANT	: Sony Corporation	FILE NO.	: ANKK-103108
EUT NAME	: Wireless LAN PC Card	REGULATION	: FCC 15.247(c), 15.209
MODEL NO.	: PCWA-C300S	TEST METHOD	: ANSI C63.4:1992
SERIAL NO.	: 0000005	DISTANCE	: 1.0 [m]
TEST MODE	: TX CH11 6Mbps Ant B	TEMPERATURE	: 22.0 [degC]
POWER SOURCE	: AC120V/60Hz	HUMIDITY	: 43.0 [%]
DATE TESTED	: Apr 08 2003	NOTE	:

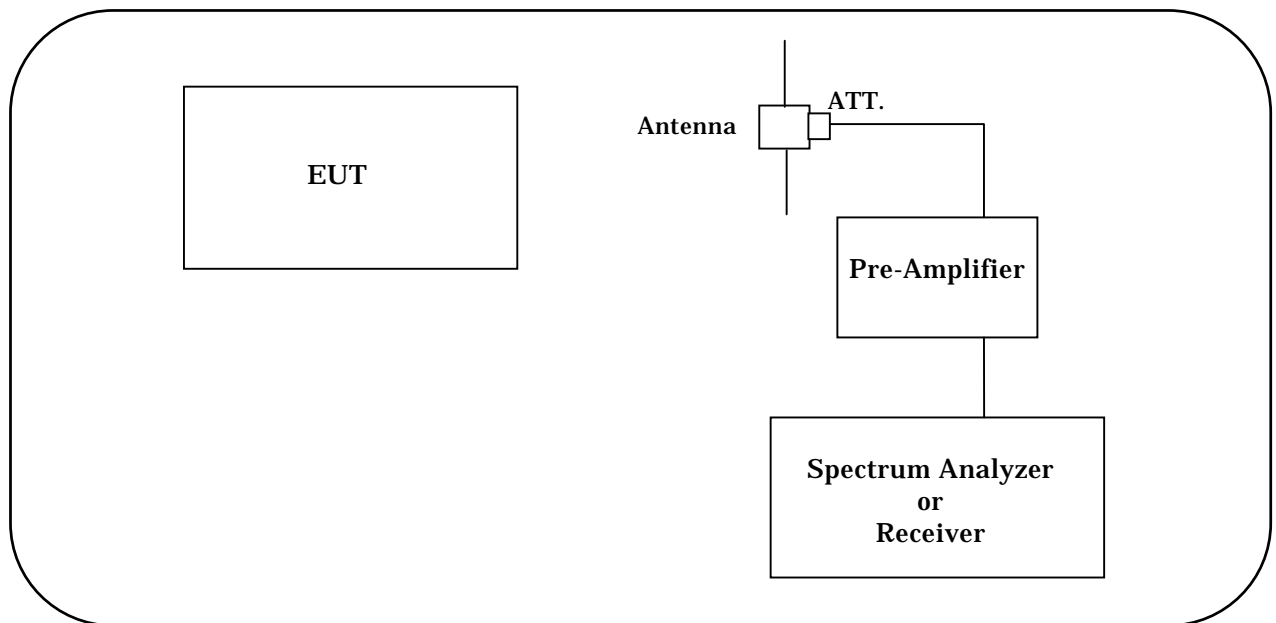
ENGINEER : Yasuhiro Kase

FREQUENCY [No]	MODE [MHz]		READING [dBuV]		FACTOR [dB]		EMISSION [dBuV/m]		LIMIT [dBuV/m]	MARGIN [dB]	
			Hori	Vert	Hori	Vert	Hori	Vert		Hori	Vert
1	4919.75	PEK	55.0	58.4	-3.8	-3.8	51.2	54.6	74.0	22.8	19.4
2	4919.75	AVG	40.6	42.4	-3.8	-3.8	36.8	38.6	54.0	17.2	15.4
3	7384.40	PEK	52.3	55.0	2.3	2.3	54.6	57.3	74.0	19.4	16.7
4	7384.40	PEK	37.8	39.3	2.3	2.3	40.1	41.6	74.0	33.9	32.4
5	9839.17	PEK	44.3	44.9	7.2	7.2	51.5	52.1	74.0	22.5	21.9
6	9839.17	AVG	29.8	30.0	7.2	7.2	37.0	37.2	54.0	17.0	16.8
7	12306.15	PEK	37.5	37.2	7.2	7.2	44.7	44.4	74.0	29.3	29.6
8	12306.15	AVG	24.8	25.1	7.2	7.2	32.0	32.3	54.0	22.0	21.7

Other frequencies : Below the FCC 15.247(c), 15.209 limit

Emission Level = Read + Factor(Antenna,Antenna Pad,Cable,Preamp)

## TEST INSTRUMENTS CONFIGURATION



## TEST INSTRUMENTS

Instrument	Model No.	Serial No.	Manufacturer	Last cal. date	Period
Test Receiver	ESS	842886/011	ROHDE & SCHWARZ	Mar. 19, 03	1 Year
Spectrum Analyzer	8564E	3643A00665	HEWLETT PACKARD	Jun. 28, 02	1 Year
Pre-Amplifier	8447D	2443A03849	HEWLETT PACKARD	Oct. 4, 02	1 Year
	83051A	3332A00329	HEWLETT PACKARD	Mar. 07, 03	1 Year
6dB Attenuator	MP721B	M57593	ANRITSU	Jan. 15, 03	1 Year
3dB Attenuator	6803.17.B	None	SUHNER	Mar. 07, 03	1 Year
Tri-log Antenna	VULB9168	107	Schwarzbeck	Jul. 31, 02	1 Year
Double Ridged Antenna	3115	5044	EMCO	Jul. 09, 02	1 Year
	3116	9612-2320	EMCO	Jul. 12, 02	1 Year
Standard Gain Horn Antenna	3160-04	1080	EMCO	Jan. 15, 03	1 Year
	3160-05	1114	EMCO	Jan. 15, 03	1 Year
	3160-06	1075	EMCO	Jan. 15, 03	1 Year
	3160-07	1160	EMCO	Jan. 15, 03	1 Year
	3160-08	1144	EMCO	Jan. 15, 03	1 Year
	3160-09	1262	EMCO	Jan. 15, 03	1 Year



**9.6 Restricted Bands of Operation [15.247(c), 15.205, 15.209]****MEASUREMENT PROCEDURE:**

1. The EUT was set to operate with following conditions.
  - ch1 / ch11
  - All Data Transfer Rate
2. Measurement distance was 1 meter.
3. The Spectrum Analyzer was setup using
  - Peak mode: RBW = 1MHz, VBW = 1MHz
  - Average mode: RBW = 1MHz, VBW = 10Hz
4. Following data is the worst case.
- 5 As for the typical chart of the observed RF profiles, refer to Page 59 – 62.

**Data of CH1 with 1Mbps in Antenna A****Akzo Nobel K. K.  
Kashima No.3 Test Site****Spurious Emissions - Bandedge**

APPLICANT : Sony Corporation  
 EUT NAME : Wireless LAN PC Card  
 MODEL NO. : PCWA-C300S  
 SERIAL NO. : 0000005  
 TEST MODE : TX CH1 1Mbps Ant.A  
 POWER SOURCE : AC120V/60Hz  
 DATE TESTED : Apr 14 2003

FILE NO. : ANKK-103108  
 REGULATION : FCC 15.247(c), 15.205, 15.209  
 TEST METHOD : ANSI C63.4:1992  
 DISTANCE : 1.0 [m]  
 TEMPERATURE : 25.0 [degC]  
 HUMIDITY : 38.0 [%]  
 NOTE :

ENGINEER : Yasuhiro Kase

FREQUENCY [No]	MODE [MHz]		READING [dBuV]		FACTOR [dB/m]		EMISSION [dBuV/m]		LIMIT [dBuV/m]	MARGIN [dB]	
			Hori	Vert	Hori	Vert	Hori	Vert		Hori	Vert
1	2390.00	PEK	39.5	39.7	18.3	18.3	57.8	58.0	74.0	16.2	16.0
2	2390.00	AVG	28.0	27.7	18.3	18.3	46.3	46.0	54.0	7.7	8.0

Other frequencies : Below the FCC 15.247(c), 15.205, 15.209 limit

Emission Level = Read + Factor(Antenna,Antenna Pad,Cable,Preamp)

**Data of CH1 with 1Mbps in Antenna B****Akzo Nobel K. K.  
Kashima No.3 Test Site****Spurious Emissions - Bandedge**

APPLICANT : Sony Corporation  
 EUT NAME : Wireless LAN PC Card  
 MODEL NO. : PCWA-C300S  
 SERIAL NO. : 0000005  
 TEST MODE : TX CH1 1Mbps Ant.B  
 POWER SOURCE : AC120V/60Hz  
 DATE TESTED : Apr 14 2003

FILE NO. : ANKK-103108  
 REGULATION : FCC 15.247(c), 15.205, 15.209  
 TEST METHOD : ANSI C63.4:1992  
 DISTANCE : 1.0 [m]  
 TEMPERATURE : 25.0 [degC]  
 HUMIDITY : 36.0 [%]  
 NOTE :

ENGINEER : Yasuhiro Kase

FREQUENCY [No]	MODE [MHz]		READING [dBuV]		FACTOR [dB/m]		EMISSION [dBuV/m]		LIMIT [dBuV/m]	MARGIN [dB]	
			Hori	Vert	Hori	Vert	Hori	Vert		Hori	Vert
1	2390.00	PEK	40.3	39.3	18.3	18.3	58.6	57.6	74.0	15.4	16.4
2	2390.00	AVG	28.8	28.0	18.3	18.3	47.1	46.3	54.0	6.9	7.7

Other frequencies : Below the FCC 15.247(c), 15.205, 15.209 limit

Emission Level = Read + Factor(Antenna,Antenna Pad,Cable,Preamp)

**Data of CH11 with 1Mbps in Antenna A****Akzo Nobel K. K.  
Kashima No.3 Test Site****Spurious Emissions - Bandedge**

APPLICANT : Sony Corporation  
 EUT NAME : Wireless LAN PC Card  
 MODEL NO. : PCWA-C300S  
 SERIAL NO. : 0000005  
 TEST MODE : TX CH11 1Mbps Ant.A  
 POWER SOURCE : AC120V/60Hz  
 DATE TESTED : Apr 14 2003

FILE NO. : ANKK-103108  
 REGULATION : FCC 15.247(c), 15.205, 15.209  
 TEST METHOD : ANSI C63.4:1992  
 DISTANCE : 1.0 [m]  
 TEMPERATURE : 25.0 [degC]  
 HUMIDITY : 38.0 [%]  
 NOTE :

ENGINEER : Yasuhiro Kase

FREQUENCY [No]	MODE [MHz]		READING [dBuV]		FACTOR [dB/m]		EMISSION [dBuV/m]		LIMIT [dBuV/m]	MARGIN [dB]	
			Hori	Vert	Hori	Vert	Hori	Vert		Hori	Vert
1	2483.50	PEK	40.3	40.5	18.4	18.4	58.7	58.9	74.0	15.3	15.1
2	2483.50	AVG	28.0	27.8	18.4	18.4	46.4	46.2	54.0	7.6	7.8

Other frequencies : Below the FCC 15.247(c), 15.205, 15.209 limit

Emission Level = Read + Factor(Antenna,Antenna Pad,Cable,Preamp)

**Data of CH11 with 1Mbps in Antenna B****Akzo Nobel K. K.  
Kashima No.3 Test Site****Spurious Emissions - Bandedge**

APPLICANT	: Sony Corporation	FILE NO.	: ANKK-103108
EUT NAME	: Wireless LAN PC Card	REGULATION	: FCC 15.247(c), 15.205, 15.209
MODEL NO.	: PCWA-C300S	TEST METHOD	: ANSI C63.4:1992
SERIAL NO.	: 0000005	DISTANCE	: 1.0 [m]
TEST MODE	: TX CH11 1Mbps Ant.B	TEMPERATURE	: 25.0 [degC]
POWER SOURCE	: AC120V/60Hz	HUMIDITY	: 38.0 [%]
DATE TESTED	: Apr 14 2003	NOTE	:

ENGINEER : Yasuhiro Kase

FREQUENCY [No]	MODE [MHz]		READING [dBuV]		FACTOR [dB/m]		EMISSION [dBuV/m]		LIMIT [dBuV/m]	MARGIN [dB]	
			Hori	Vert	Hori	Vert	Hori	Vert		Hori	Vert
1	2483.50	PEK	40.7	39.5	18.4	18.4	59.1	57.9	74.0	14.9	16.1
2	2483.50	AVG	28.7	28.2	18.4	18.4	47.1	46.6	54.0	6.9	7.4

Other frequencies : Below the FCC 15.247(c), 15.205, 15.209 limit

Emission Level = Read + Factor(Antenna,Antenna Pad,Cable,Preamp)

**Data of CH1 with 6Mbps in Antenna A****Akzo Nobel K. K.  
Kashima No.3 Test Site****Spurious Emissions - Bandedge**

APPLICANT : Sony Corporation  
 EUT NAME : Wireless LAN PC Card  
 MODEL NO. : PCWA-C300S  
 SERIAL NO. : 0000005  
 TEST MODE : TX CH1 6Mbps Ant.A  
 POWER SOURCE : AC120V/60Hz  
 DATE TESTED : Apr 14 2003

FILE NO. : ANKK-103108  
 REGULATION : FCC 15.247(c), 15.205, 15.209  
 TEST METHOD : ANSI C63.4:1992  
 DISTANCE : 1.0 [m]  
 TEMPERATURE : 25.0 [degC]  
 HUMIDITY : 38.0 [%]  
 NOTE :

ENGINEER : Yasuhiro Kase

FREQUENCY [No]	MODE [MHz]		READING [dBuV]		FACTOR [dB/m]		EMISSION [dBuV/m]		LIMIT [dBuV/m]	MARGIN [dB]	
			Hori	Vert	Hori	Vert	Hori	Vert		Hori	Vert
1	2390.00	PEK	49.2	42.7	18.3	18.3	67.5	61.0	74.0	6.5	13.0
2	2390.00	AVG	31.0	28.2	18.3	18.3	49.3	46.5	54.0	4.7	7.5

Other frequencies : Below the FCC 15.247(c), 15.205, 15.209 limit

Emission Level = Read + Factor(Antenna,Antenna Pad,Cable,Preamp)

**Data of CH1 with 6Mbps in Antenna B****Akzo Nobel K. K.  
Kashima No.3 Test Site****Spurious Emissions - Bandedge**

APPLICANT : Sony Corporation  
 EUT NAME : Wireless LAN PC Card  
 MODEL NO. : PCWA-C300S  
 SERIAL NO. : 0000005  
 TEST MODE : TX CH1 6Mbps Ant.B  
 POWER SOURCE : AC120V/60Hz  
 DATE TESTED : Apr 14 2003

FILE NO. : ANKK-103108  
 REGULATION : FCC 15.247(c), 15.205, 15.209  
 TEST METHOD : ANSI C63.4:1992  
 DISTANCE : 1.0 [m]  
 TEMPERATURE : 25.0 [degC]  
 HUMIDITY : 38.0 [%]  
 NOTE :

ENGINEER : Yasuhiro Kase

FREQUENCY [No]	MODE [MHz]		READING [dBuV]		FACTOR [dB/m]		EMISSION [dBuV/m]		LIMIT [dBuV/m]	MARGIN [dB]	
			Hori	Vert	Hori	Vert	Hori	Vert		Hori	Vert
1	2390.00	PEK	47.7	45.8	18.3	18.3	66.0	64.1	74.0	8.0	9.9
2	2390.00	AVG	30.5	29.5	18.3	18.3	48.8	47.8	54.0	5.2	6.2

Other frequencies : Below the FCC 15.247(c), 15.205, 15.209 limit

Emission Level = Read + Factor(Antenna,Antenna Pad,Cable,Preamp)

**Data of CH11 with 9Mbps in Antenna A****Akzo Nobel K. K.  
Kashima No.3 Test Site****Spurious Emissions - Bandedge**

APPLICANT	: Sony Corporation	FILE NO.	: ANKK-103108
EUT NAME	: Wireless LAN PC Card	REGULATION	: FCC 15.247(c), 15.205, 15.209
MODEL NO.	: PCWA-C300S	TEST METHOD	: ANSI C63.4:1992
SERIAL NO.	: 0000005	DISTANCE	: 1.0 [m]
TEST MODE	: TX CH11 9Mbps Ant.A	TEMPERATURE	: 25.0 [degC]
POWER SOURCE	: AC120V/60Hz	HUMIDITY	: 38.0 [%]
DATE TESTED	: Apr 14 2003	NOTE	:

ENGINEER : Yasuhiro Kase

FREQUENCY [No]	MODE [MHz]		READING [dBuV]		FACTOR [dB/m]		EMISSION [dBuV/m]		LIMIT [dBuV/m]	MARGIN [dB]	
			Hori	Vert	Hori	Vert	Hori	Vert		Hori	Vert
1	2483.50	PEK	52.5	48.7	18.4	18.4	70.9	67.1	74.0	3.1	6.9
2	2483.50	AVG	31.3	29.5	18.4	18.4	49.7	47.9	54.0	4.3	6.1

Other frequencies : Below the FCC 15.247(c), 15.205, 15.209 limit

Emission Level = Read + Factor(Antenna,Antenna Pad,Cable,Preamp)



**Data of CH11 with 9Mbps in Antenna B****Akzo Nobel K. K.  
Kashima No.3 Test Site****Spurious Emissions - Bandedge**

APPLICANT	: Sony Corporation	FILE NO.	: ANKK-103108
EUT NAME	: Wireless LAN PC Card	REGULATION	: FCC 15.247(c), 15.205, 15.209
MODEL NO.	: PCWA-C300S	TEST METHOD	: ANSI C63.4:1992
SERIAL NO.	: 0000005	DISTANCE	: 1.0 [m]
TEST MODE	: TX CH11 9Mbps Ant.B	TEMPERATURE	: 25.0 [degC]
POWER SOURCE	: AC120V/60Hz	HUMIDITY	: 38.0 [%]
DATE TESTED	: Apr 14 2003	NOTE	:

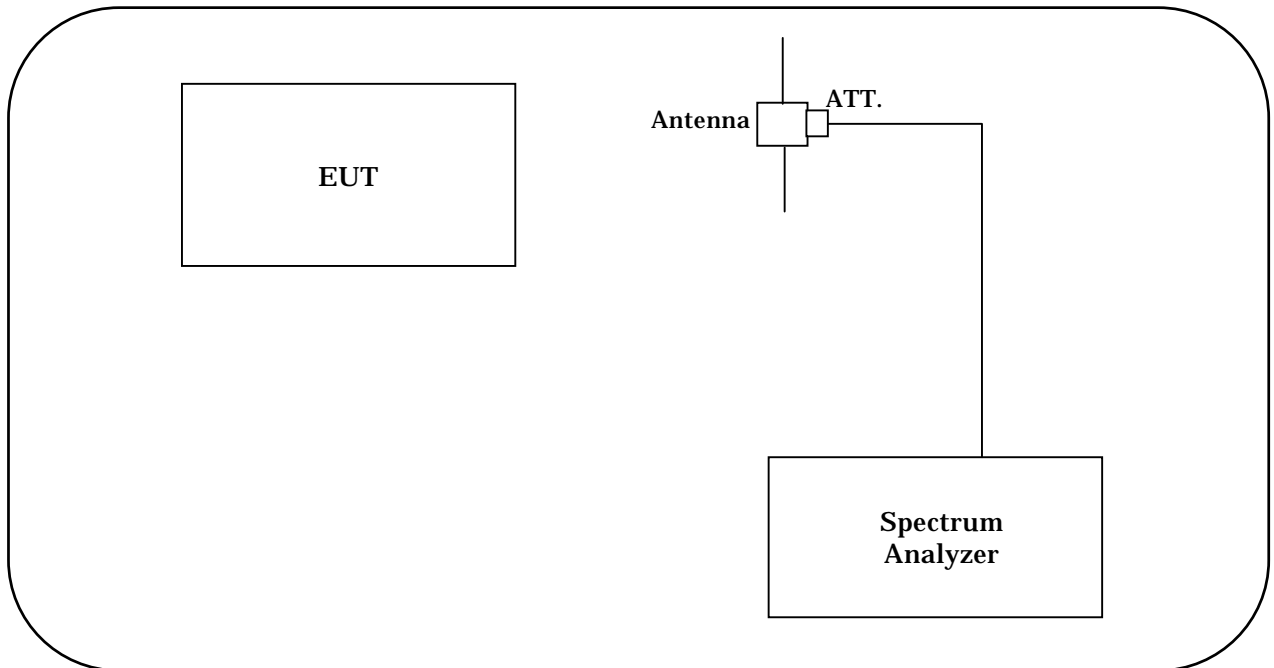
ENGINEER : Yasuhiro Kase

FREQUENCY [No]	MODE [MHz]		READING [dBuV]		FACTOR [dB/m]		EMISSION [dBuV/m]		LIMIT [dBuV/m]	MARGIN [dB]	
			Hori	Vert	Hori	Vert	Hori	Vert		Hori	Vert
1	2483.50	PEK	46.0	45.0	18.4	18.4	64.4	63.4	74.0	9.6	10.6
2	2483.50	AVG	29.5	29.7	18.4	18.4	47.9	48.1	54.0	6.1	5.9

Other frequencies : Below the FCC 15.247(c), 15.205, 15.209 limit

Emission Level = Read + Factor(Antenna,Antenna Pad,Cable,Preamp)

## TEST INSTRUMENTS CONFIGURATION



## TEST INSTRUMENTS

Instrument	Model No.	Serial No.	Manufacturer	Last cal. date	Period
Spectrum Analyzer	8564E	3643A00665	HEWLETT PACKARD	Jun. 28, 02	1 Year
3dB Attenuator	6803.17.B	None	SUHNER	Mar. 07, 03	1 Year
Double Ridged Guide Antenna	3115	5044	EMCO	Jul. 09, 02	1 Year

Chart of ch1 with 1Mbps in Antenna A

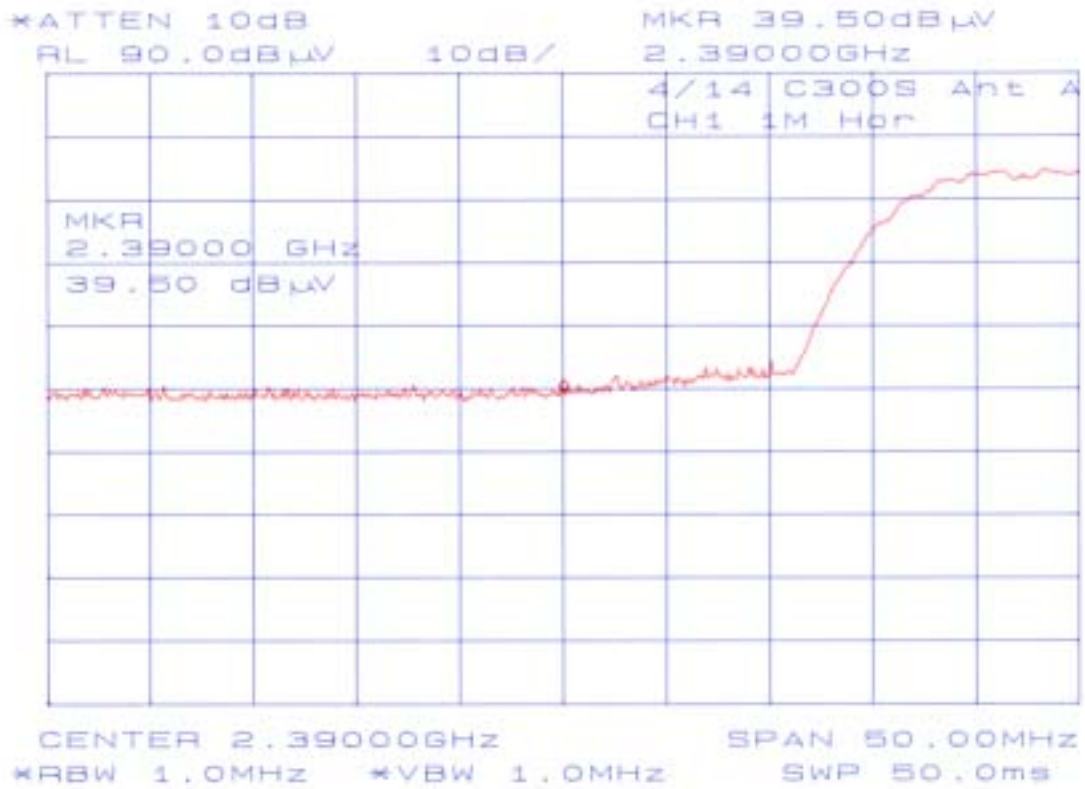


Chart of ch1 with 1Mbps in Antenna A

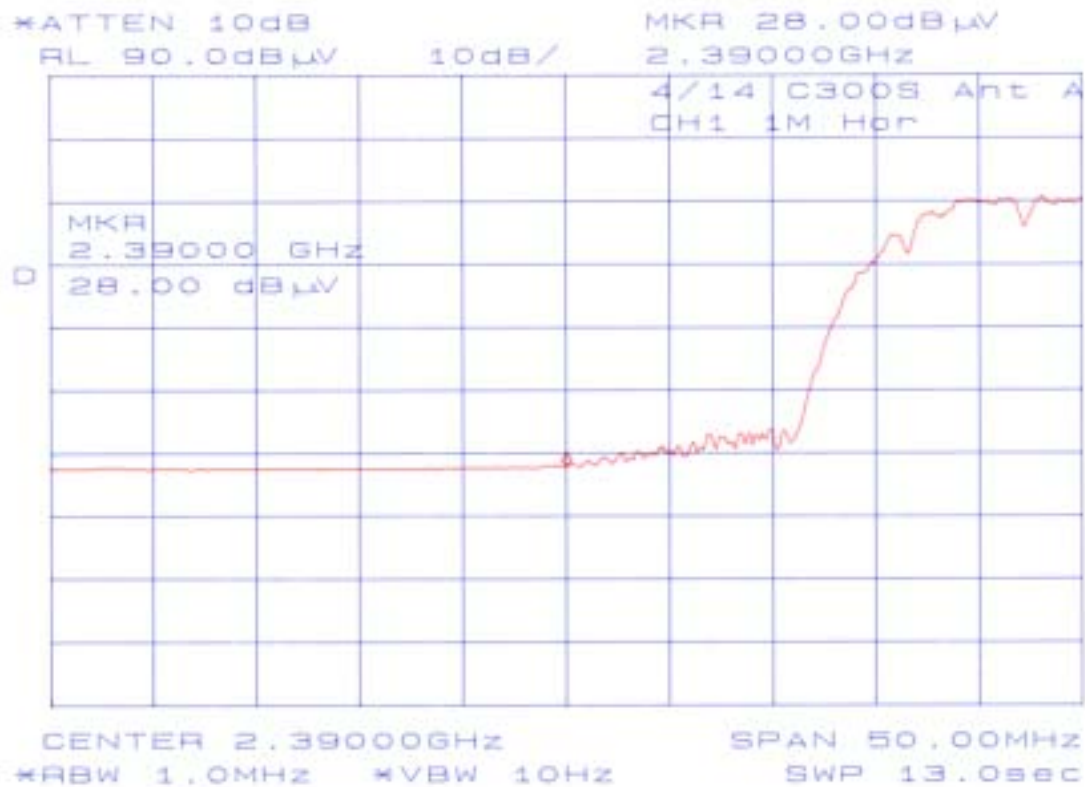


Chart of ch11 with 1Mbps in Antenna A

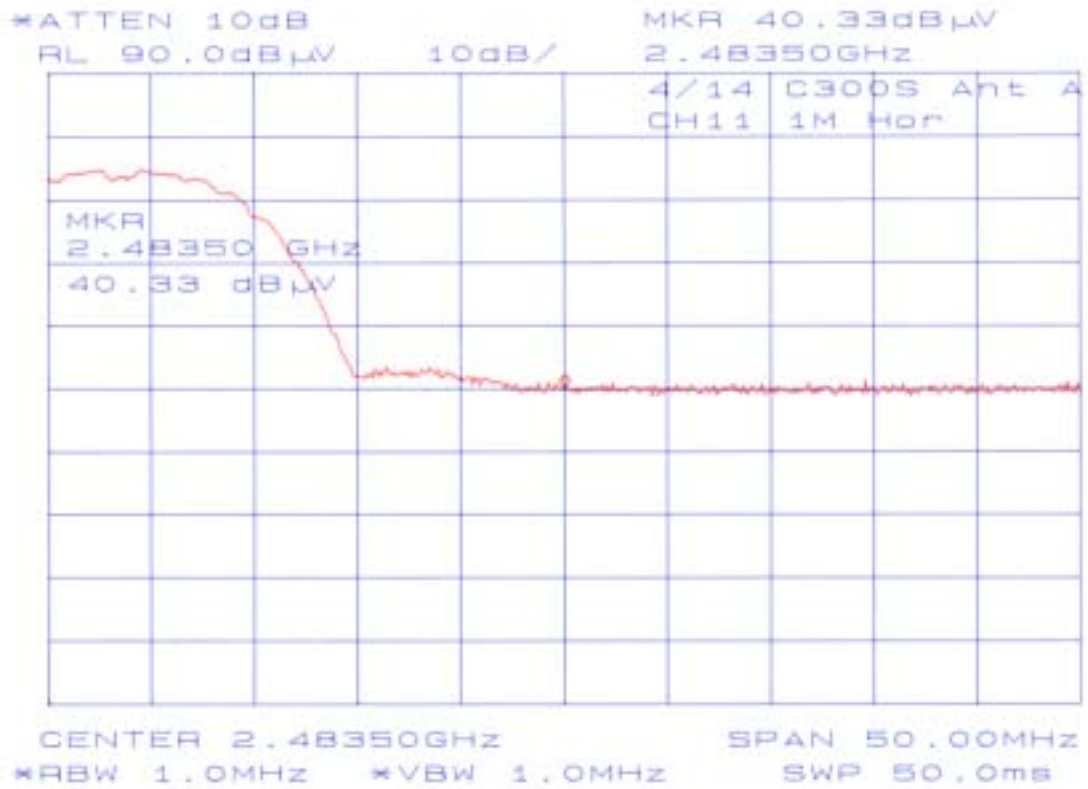


Chart of ch11 with 1Mbps in Antenna A

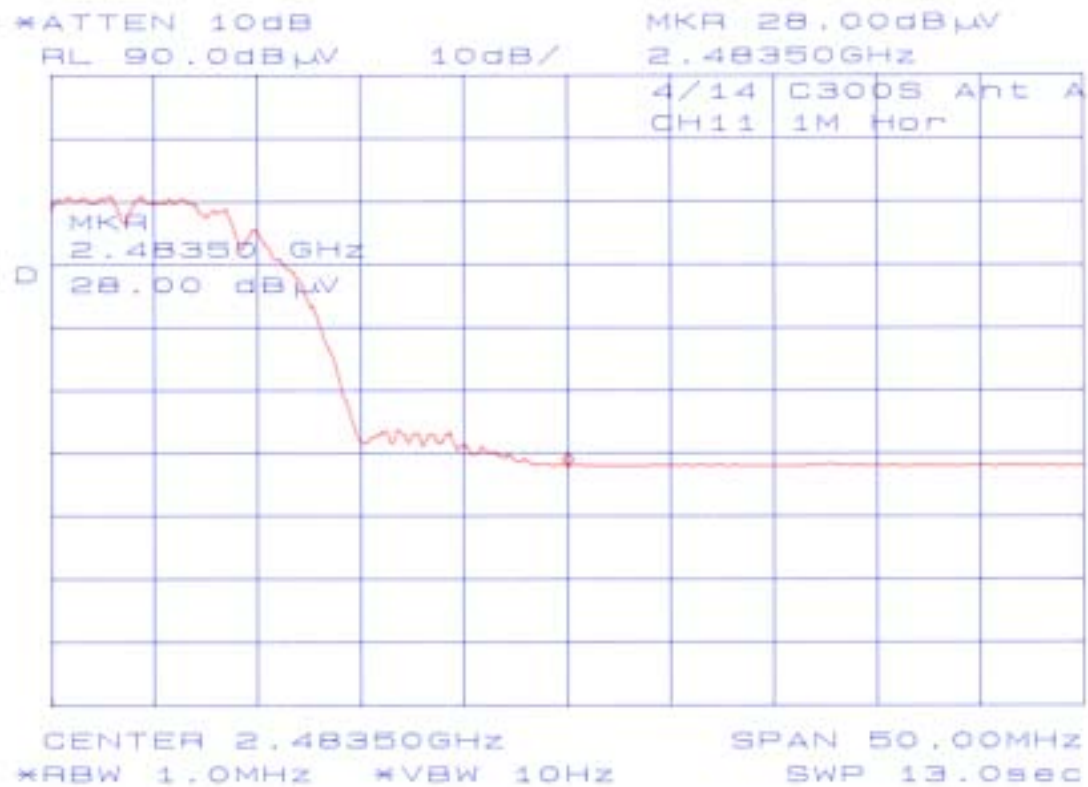


Chart of ch1 with 6Mbps in Antenna A

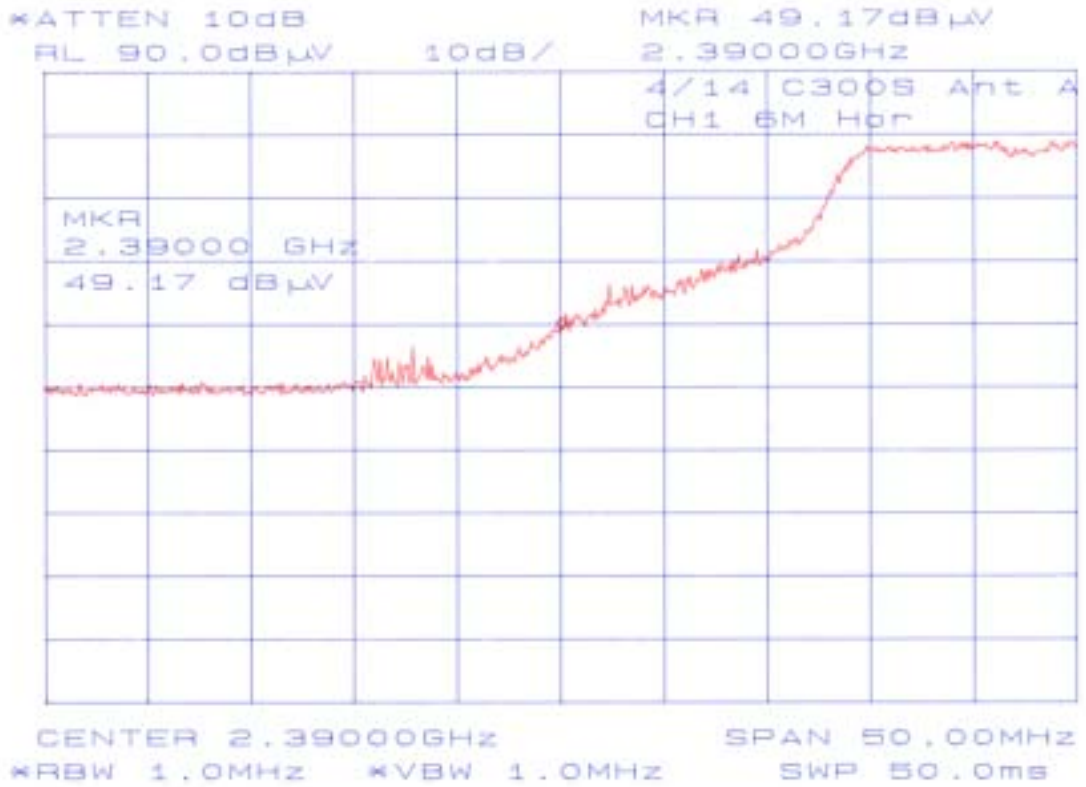


Chart of ch1 with 6Mbps in Antenna A

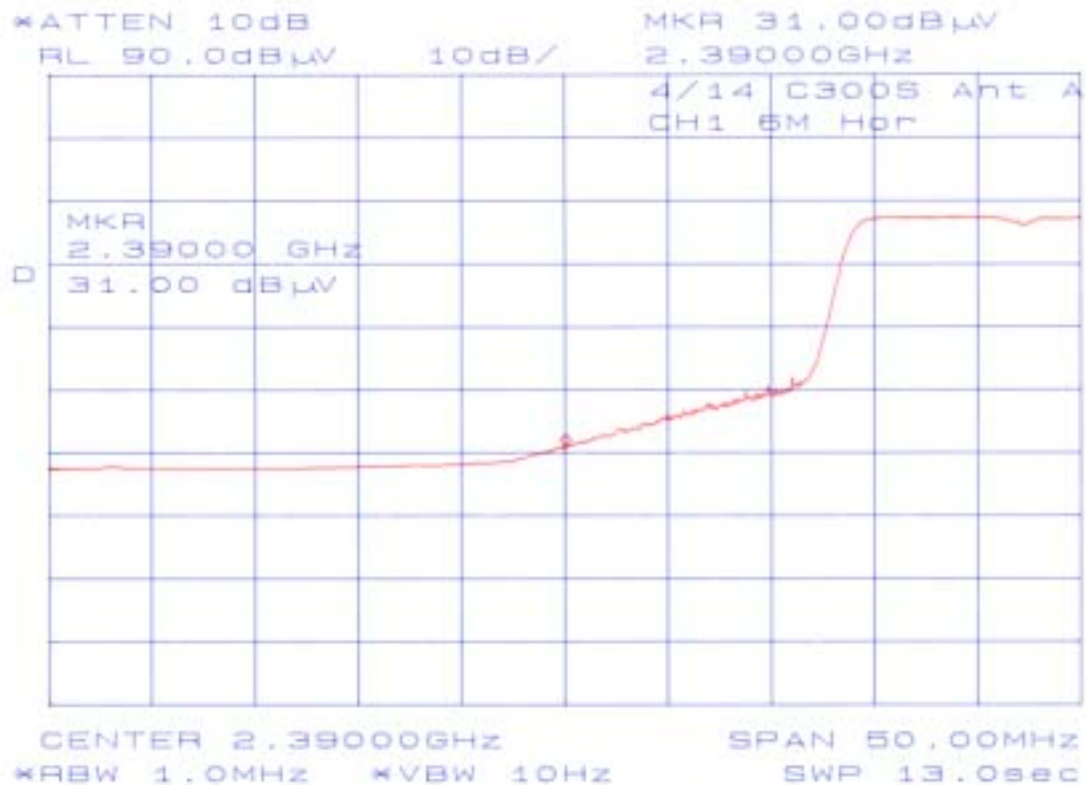


Chart of ch11 with 9Mbps in Antenna A

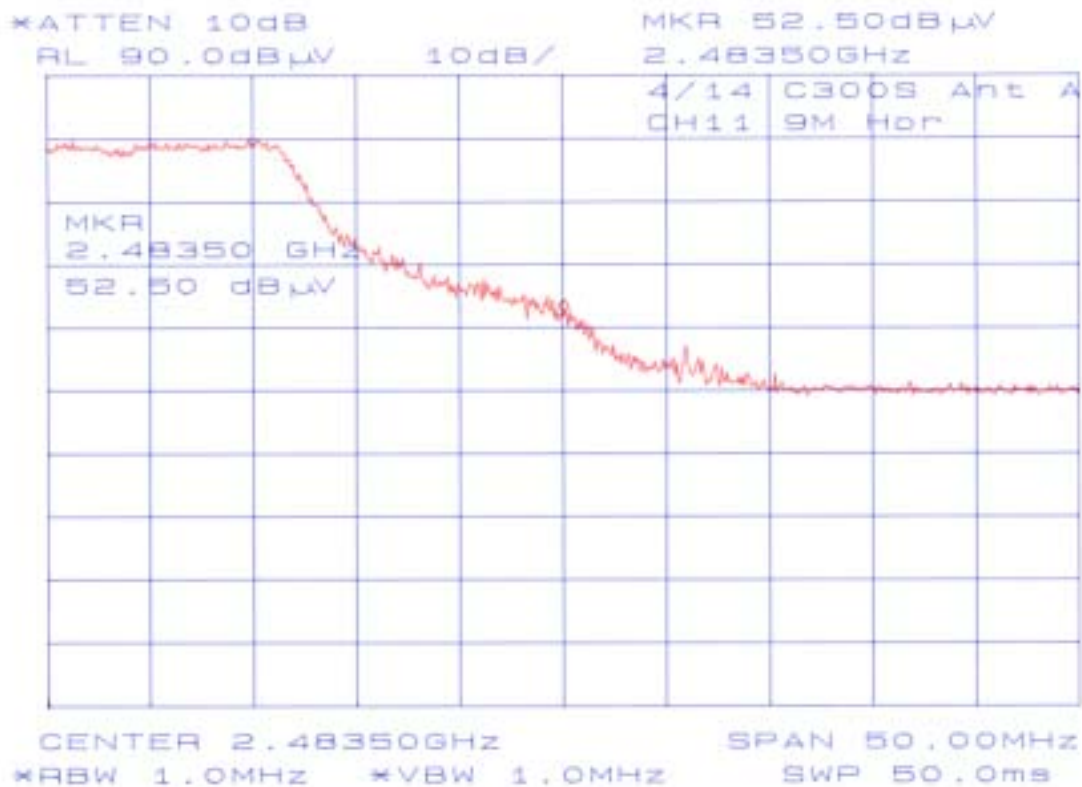
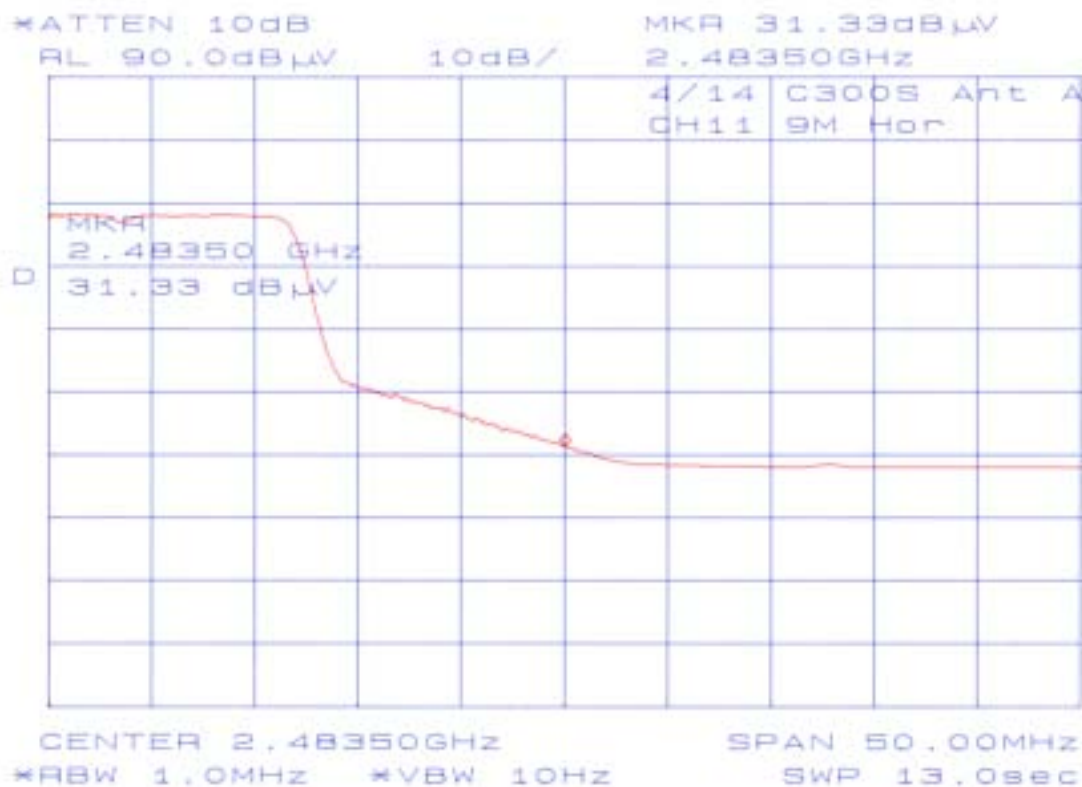


Chart of ch11 with 9Mbps in Antenna A



**9.7 AC Conducted Emissions [15.207]****MEASUREMENT PROCEDURE:**

1. The EUT was set to operate with following conditions.
  - ch1 / ch6 / ch11
  - All Data Transfer Rate
2. The Test Receiver is complied with the specification of the CISPR publication 16.
3. Following data is the worst case.

**Data of CH6 with 1Mbps in Antenna B****Akzo Nobel K. K.  
Kashima No.3 Test Site****Conducted Voltages on Mains Port**

APPLICANT	: Sony Corporation	FILE NO.	: ANKK-103108
EUT NAME	: Wireless LAN PC Card	REGULATION	: FCC 15.207
MODEL NO.	: PCWA-C300S	TEST METHOD	: ANSI C63.4-1992
SERIAL NO.	: 0000005		
TEST MODE	: TX CH06 1Mbps Ant B	TEMPERATURE	: 22.0 [degC]
POWER SOURCE	: AC120V/60Hz	HUMIDITY	: 43.0 [%]
DATE TESTED	: Apr 10 2003	NOTE	:

ENGINEER : Yasuhiro Kase

FREQUENCY [No]	MODE [MHz]		READING [dBuV]		FACTOR [dB]		EMISSION [dBuV]		LIMIT [dBuV]	MARGIN [dB]	
			Line1	Line2	Line1	Line2	Line1	Line2		Line1	Line2
1	0.1766	QP	39.7	43.0	6.7	6.7	46.4	49.7	64.6	18.2	14.9
2	0.4444	QP	22.5	31.4	6.7	6.7	29.2	38.1	57.0	27.8	18.9
3	0.5285	QP	24.7	32.4	6.7	6.7	31.4	39.1	56.0	24.6	16.9
4	1.4360	QP	23.0	24.3	6.7	6.8	29.7	31.1	56.0	26.3	24.9
5	4.7085	QP	23.2	24.3	6.9	6.9	30.1	31.2	56.0	25.9	24.8
6	7.3496	QP	36.2	35.7	7.1	7.1	43.3	42.8	60.0	16.7	17.2
7	8.2213	QP	38.9	38.7	7.1	7.1	46.0	45.8	60.0	14.0	14.2

Other frequencies : Below the FCC 15.207 limit

Emission Level = Read + Factor(LISN,Pad,Cable)



**Data of CH11 with 6Mbps in Antenna B****Akzo Nobel K. K.  
Kashima No.3 Test Site****Conducted Voltages on Mains Port**

APPLICANT	: Sony Corporation	FILE NO.	: ANKK-103108
EUT NAME	: Wireless LAN PC Card	REGULATION	: FCC 15.207
MODEL NO.	: PCWA-C300S	TEST METHOD	: ANSI C63.4-1992
SERIAL NO.	: 0000005		
TEST MODE	: TX CH11 6Mbps Ant B	TEMPERATURE	: 22.0 [degC]
POWER SOURCE	: AC120V/60Hz	HUMIDITY	: 43.0 [%]
DATE TESTED	: Apr 10 2003	NOTE	:

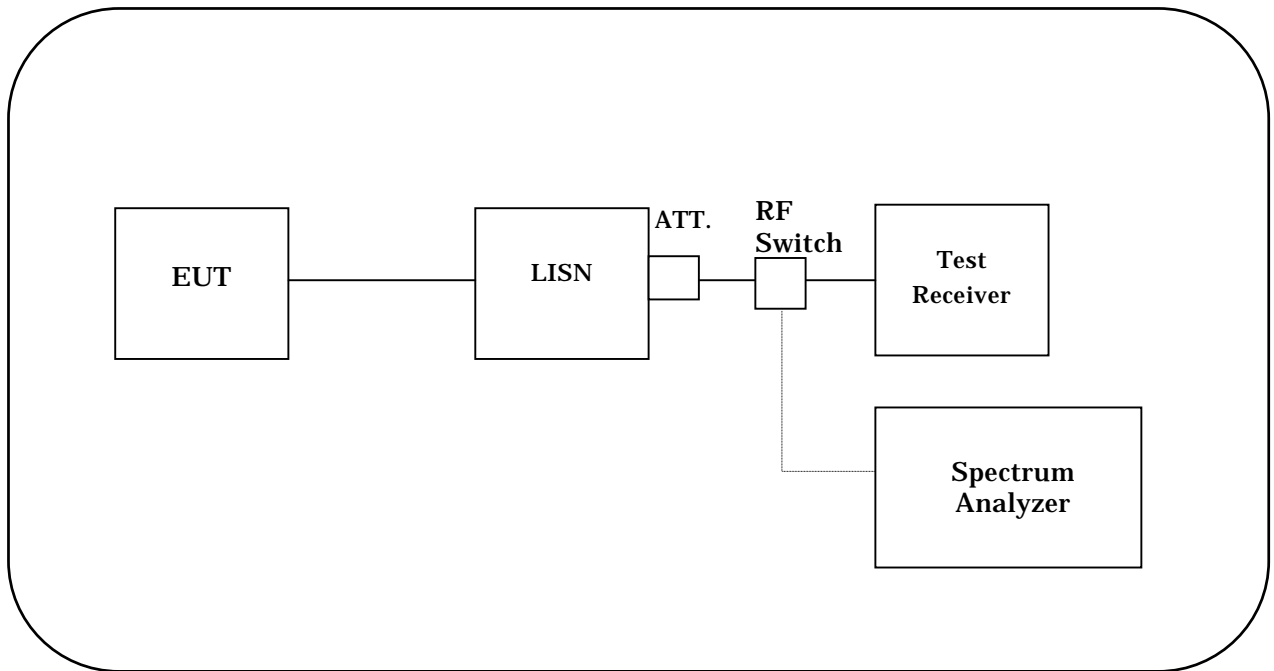
ENGINEER : Yasuhiro Kase

FREQUENCY [No]	MODE [MHz]		READING [dBuV]		FACTOR [dB]		EMISSION [dBuV]		LIMIT [dBuV]	MARGIN [dB]	
			Line1	Line2	Line1	Line2	Line1	Line2		Line1	Line2
1	0.1766	QP	39.6	43.0	6.7	6.7	46.3	49.7	64.6	18.3	14.9
2	0.4444	QP	22.4	31.5	6.7	6.7	29.1	38.2	57.0	27.9	18.8
3	0.5285	QP	24.8	32.4	6.7	6.7	31.5	39.1	56.0	24.5	16.9
4	1.4360	QP	23.0	25.1	6.7	6.8	29.7	31.9	56.0	26.3	24.1
5	4.7085	QP	22.4	24.2	6.9	6.9	29.3	31.1	56.0	26.7	24.9
6	7.3496	QP	36.3	35.8	7.1	7.1	43.4	42.9	60.0	16.6	17.1
7	8.2213	QP	38.7	38.6	7.1	7.1	45.8	45.7	60.0	14.2	14.3

Other frequencies : Below the FCC 15.207 limit

Emission Level = Read + Factor(LISN,Pad,Cable)

## TEST INSTRUMENTS CONFIGURATION



## TEST INSTRUMENTS

Instrument	Model No.	Serial No.	MANUFACTURER	Last cal. date	Period
Test receiver	ESS	842886/011	ROHDE & SCHWARZ	Mar. 19, 03	1 Year
LISN (EUT)	ESH2-Z5	881492/014	ROHDE & SCHWARZ	Sep. 30, 02	1 Year
6dB Attenuator	CFA-01	None	TME	Jan. 15, 03	1 Year
LISN (Peripheral)	KNW-407	8-532-11	KYORITSU	Mar. 19, 03	1 Year
50Ω Termination	CT-01	A030CON50	TME	Jun. 26, 02	1 Year
RF Switch	ACX-150	None	AKZO NOBEL	Jan. 15, 03	1 Year

**SECTION 10. MEASUREMENT UNCERTAINTY**

The uncertainty of the measurements performed for this report lies:

Minimum 6dB Bandwidth	[15.247(a)(2)]	
Above 1 GHz .....		+/- 46.7kHz
Maximum Peak Output Power	[15.247(b)]	
Above 1 GHz .....		+/- 0.2 dB
Spurious Emissions		
- RF Antenna Conducted Test	[15.247(c)]	
Above 1 GHz .....		+/- 2.9 dB
Spurious Emissions		
- Radiated Emission Test	[15.247(c), 15.205, 15.209]	
Above 1 GHz .....		+/- 3.9 dB
Power Spectral Density	[15.247(d)]	
Above 1 GHz .....		+/- 2.9 dB
AC Conducted Emission	[15.207]	
9 kHz – 30 MHz .....		+/- 1.8 dB

**Note on Radiated Emission measurement uncertainty**

The following items are not included in the calculations in spite of their own uncertainty components because it is impracticable to find the value.

It is our problem awaiting solution in future.

**(1) Repeatability of measurement**

It is not possible to calculate repeatability since the measurement was carried out only one time.

**(2) Antenna factor variation**

The definition of measured (radiated electric field strength) is not completed on the referred standard(s).

**(3) Loss of EUT radiation propagation**

It is certainly one of the uncertainty components, however is not able to calculate.

Please note that these uncertainties are not reflected to the compliance judgement of the test results in this report.

## SECTION 11. DESCRIPTION OF TEST LABORATORY

### 11.1 Outline of Akzo Nobel K. K. (formerly Akzo Kashima Limited), EMC Division

Akzo Nobel K. K., the country organization in Japan for Akzo Nobel NV, was established in 1968. The shares are owned by Akzo Nobel NV (100%). Akzo Nobel NV, headquartered in the Netherlands, is one of the world's leading companies in selected areas of chemicals, coatings, healthcare products and fibers with work force of approximately 70,000 people in over 50 countries.

In 1984, in order to respond to the growing testing demand, in particular, for FCC filing, Akzo Nobel K. K. started EMI testing business, installing the first open air test site in Kashima, Ibaraki prefecture. Further the business has been expanded by installing additional testing facilities not only in Ibaraki but also in other areas such as Shizuoka, Nagano, Kanagawa and Tochigi. As results, Akzo Nobel K. K. has now 16 open air test sites and 4 anechoic chambers for EMI/EMC testing. As the largest EMC testing laboratory in number of testing facilities and staffs, EMC Division has been organized separately in the company and independently operated in conformity with the requirements of ISO/IEC 17025 for its competency as a testing laboratory.

Akzo Nobel K. K. EMC Division is the first foreign private laboratory accredited by NVLAP, National Voluntary Laboratory Accreditation Program-NIST, USA. The division has been certified, authorized and/or filed as a competent testing laboratory by various testing organizations/authorities as described below.

### 11.2 Filing, certification, authorization and accreditation list

#### EMI/EMC testing

FCC	(USA)
NVLAP	(USA)
NEMKO	(Norway)
VCCI	(Japan)
ETL SEMKO	(Sweden)
TÜV PRODUCT SERVICE	(Germany)

#### Telecommunications terminal testing

FCC	(USA)
NVLAP	(USA)
NATA	(Australia)
IC	(Canada)

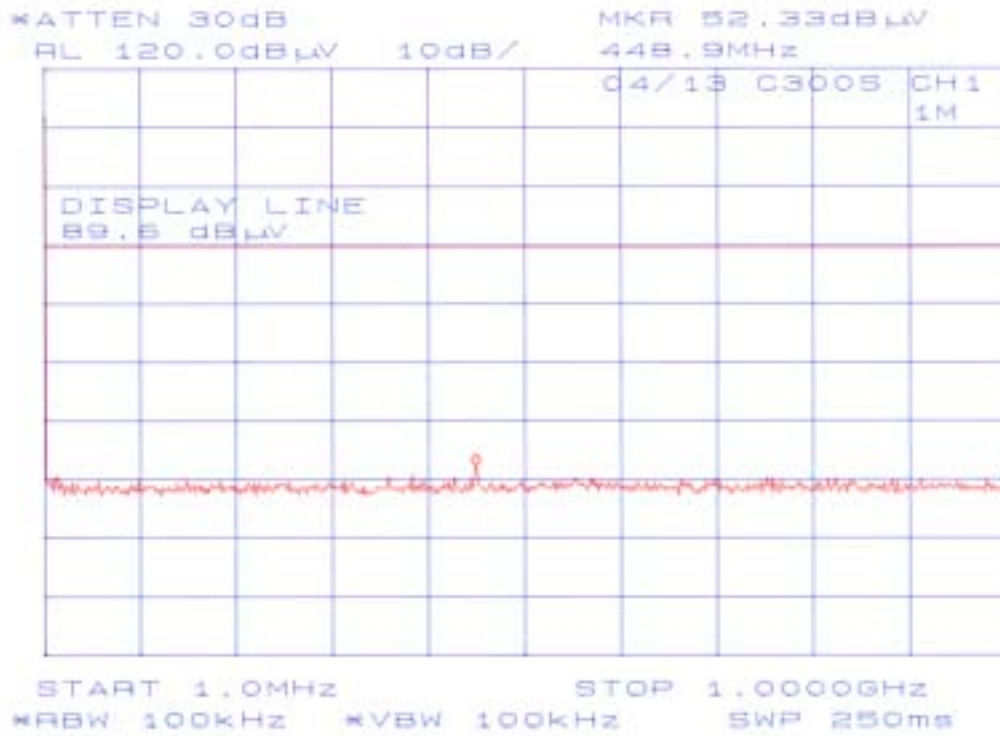
Note 1 : NVLAP accreditation does not constitute any product endorsement by NVLAP or any agent of the U.S. Government.

## **Annex A**

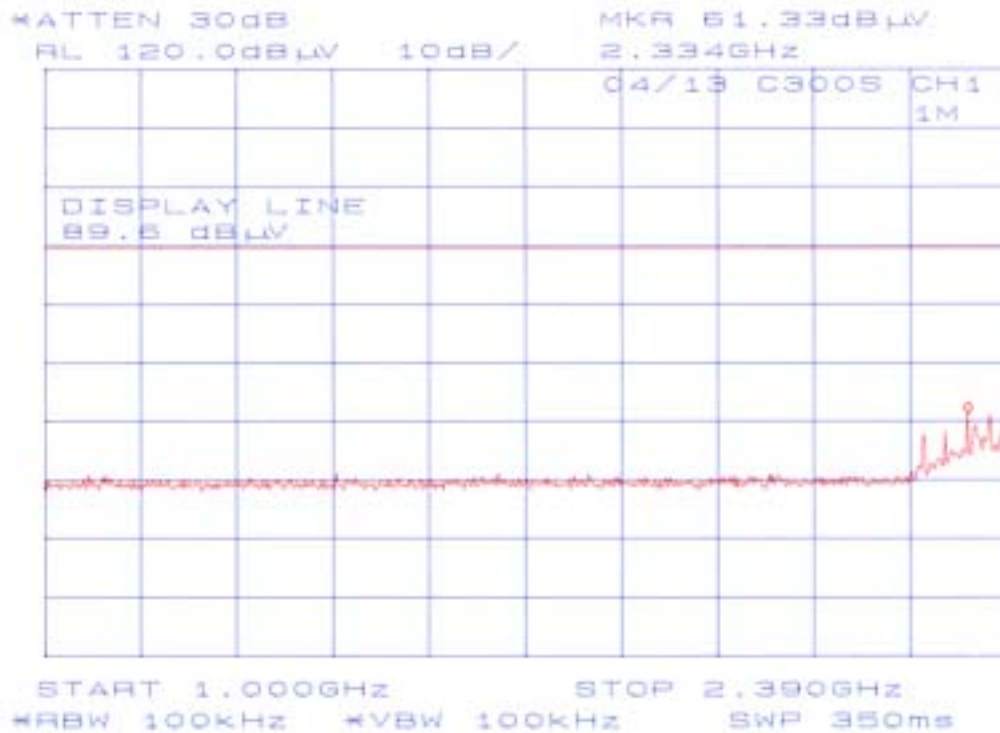
### **Spurious Emissions – RF Antenna Conducted Test**

**Modulation Method : 2.4GHz DS-SS  
(Test mode)**

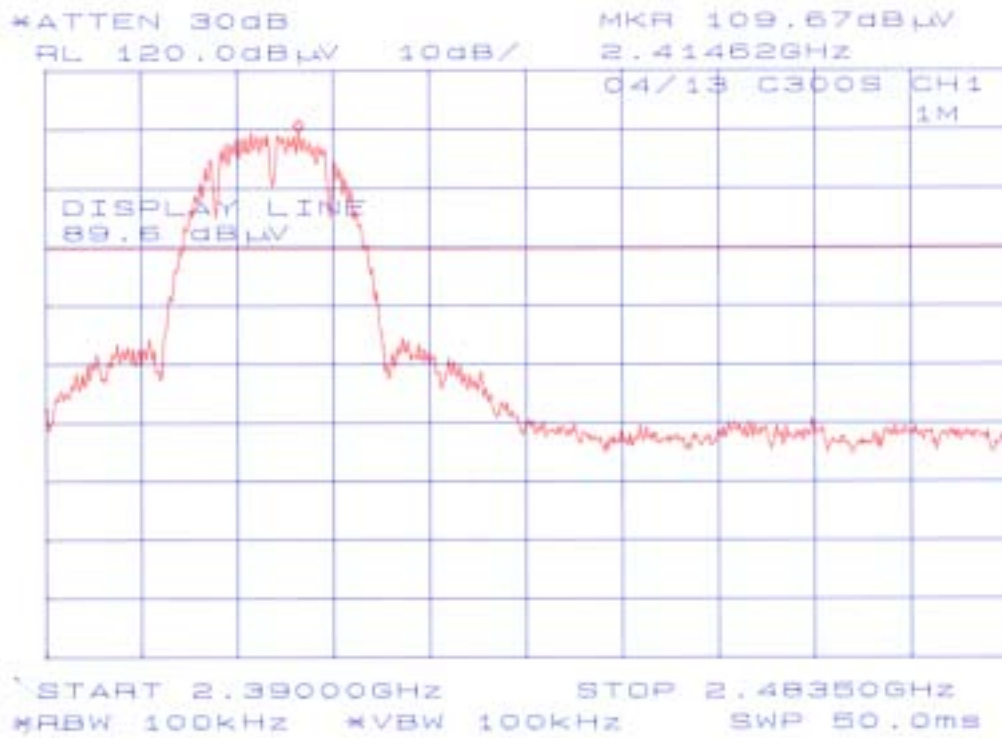
**Chart of CH1 with 1Mbps (1MHz-1GHz)**



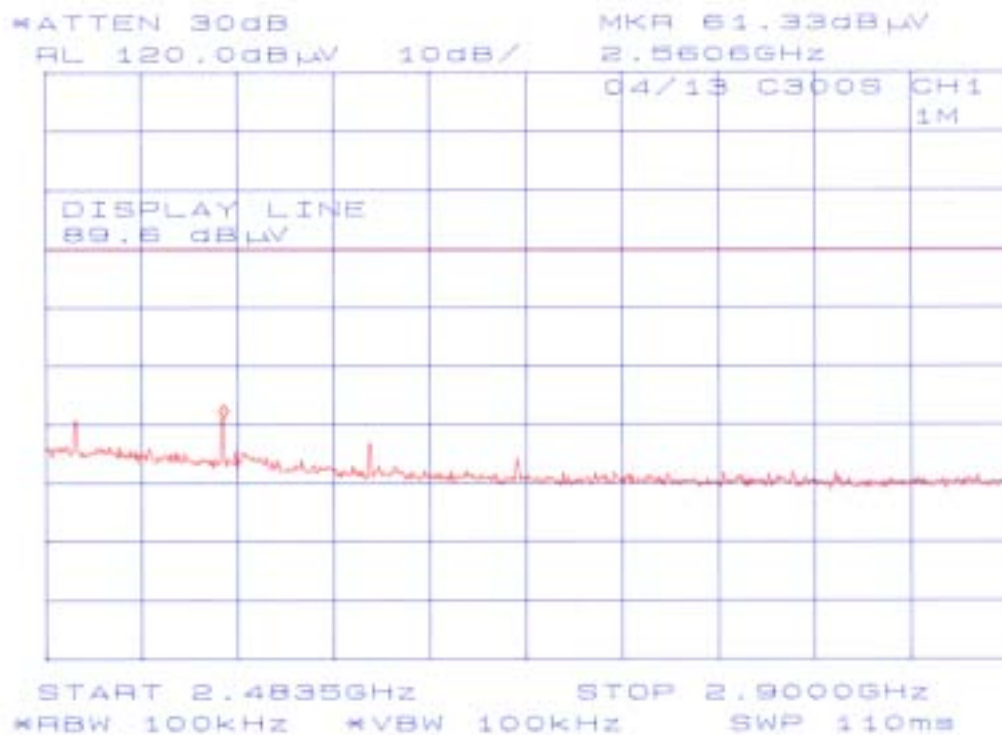
**Chart of CH1 with 1Mbps (1GHz-2.390GHz)**



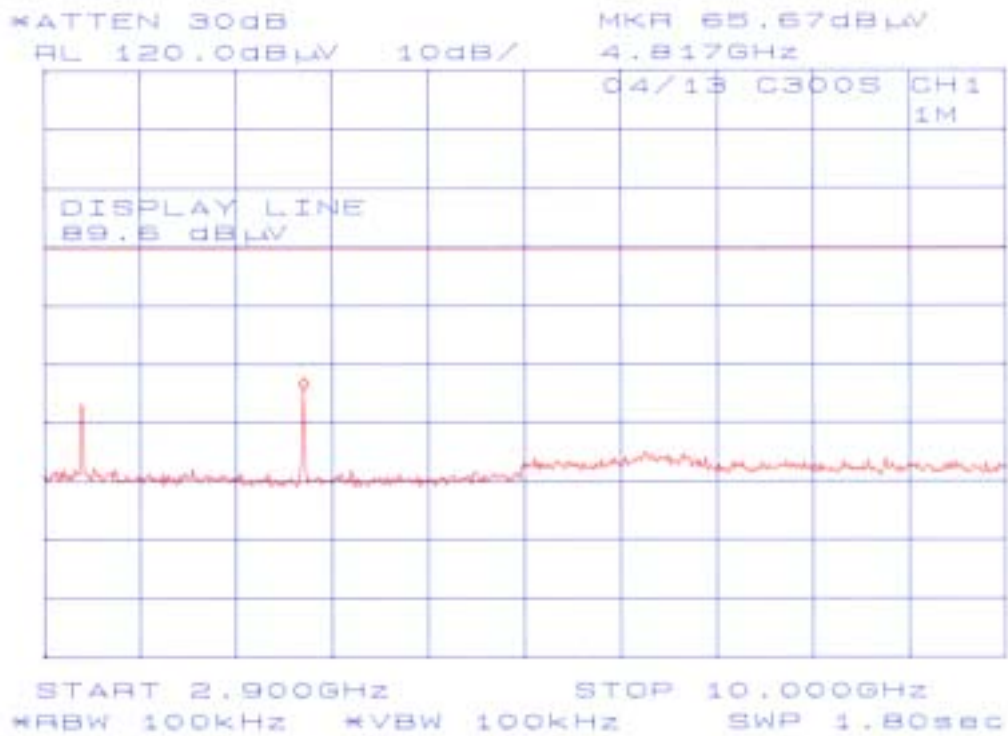
**Chart of CH1 with 1Mbps (2.390GHz-2.4835GHz)**



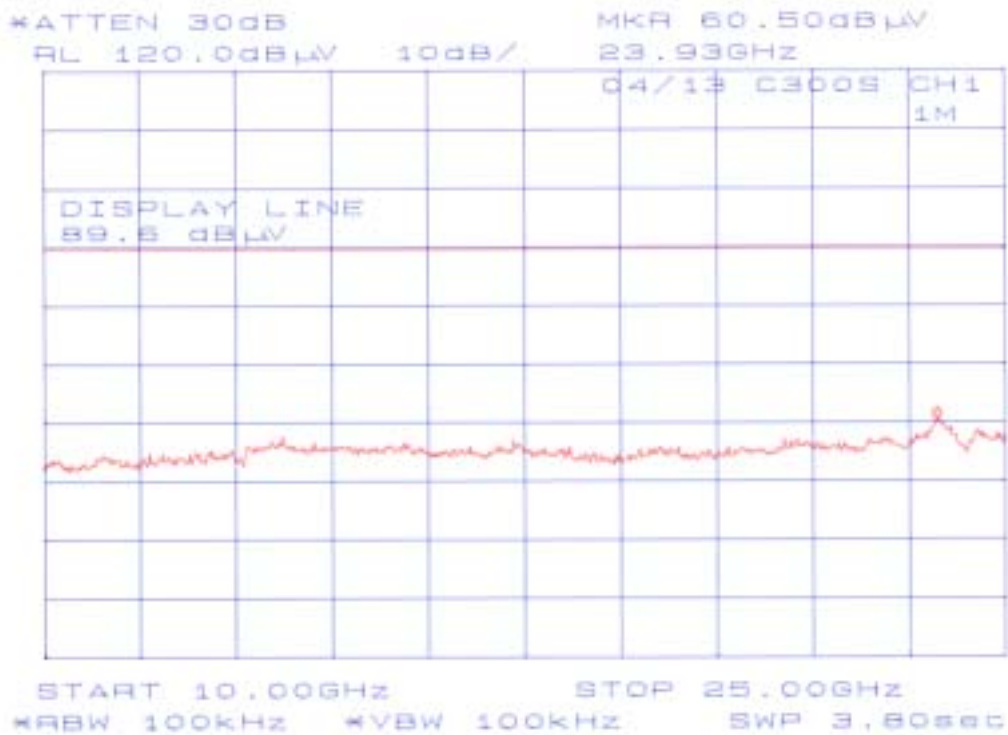
**Chart of CH1 with 1Mbps (2.4835GHz-2.9GHz)**



**Chart of CH1 with 1Mbps (2.9GHz-10GHz)**

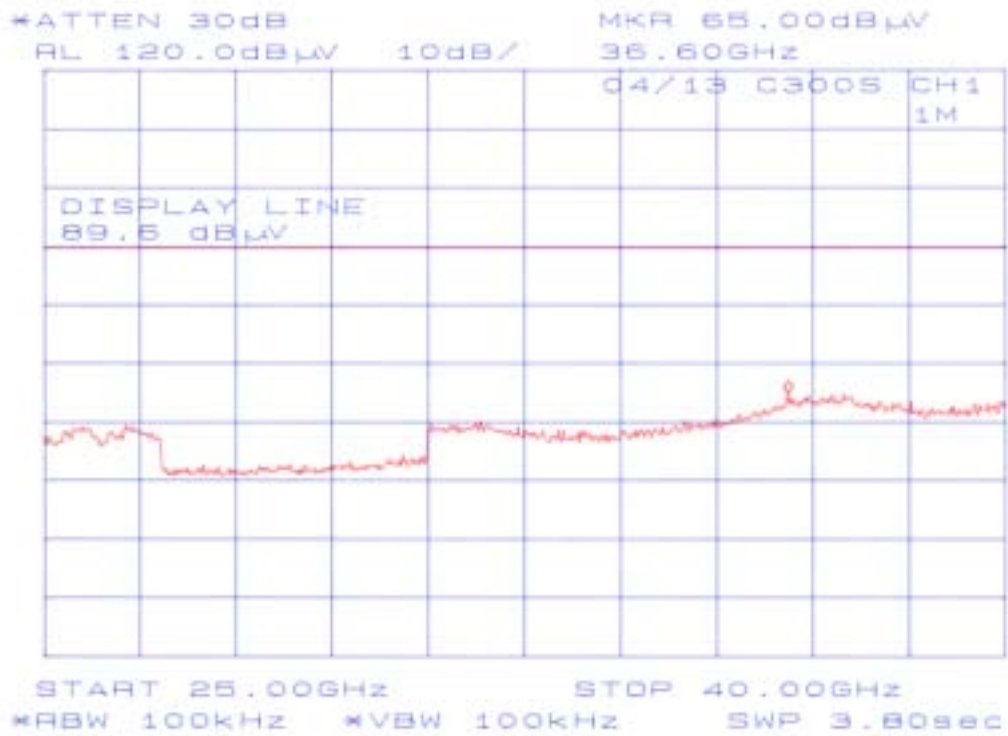


**Chart of CH1 with 1Mbps (10GHz-25GHz)**

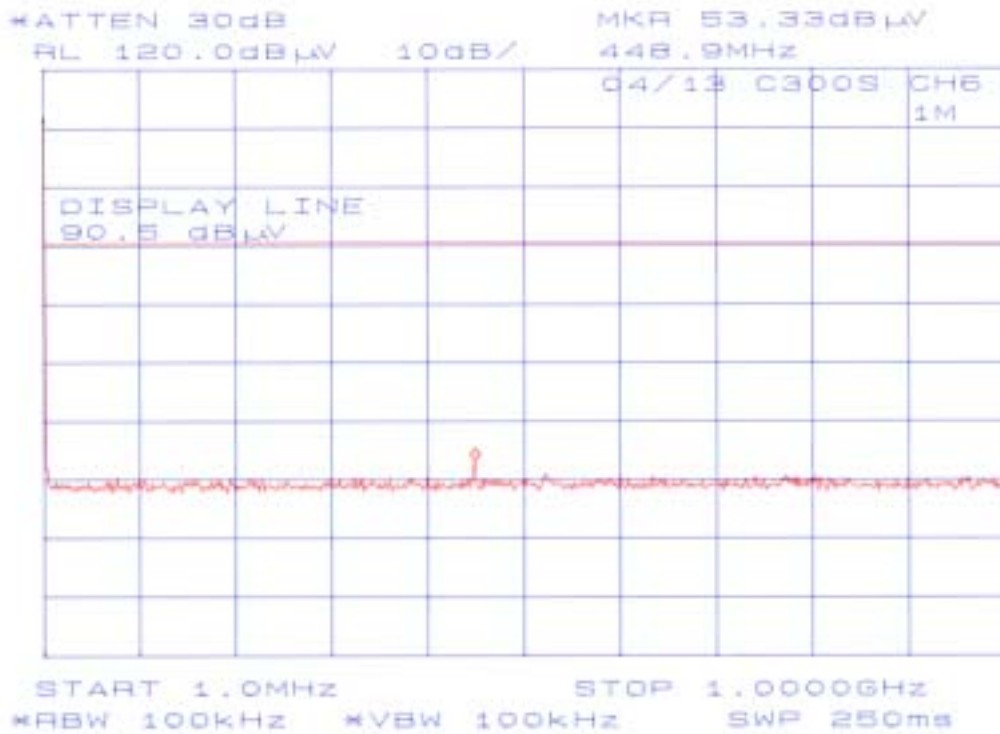




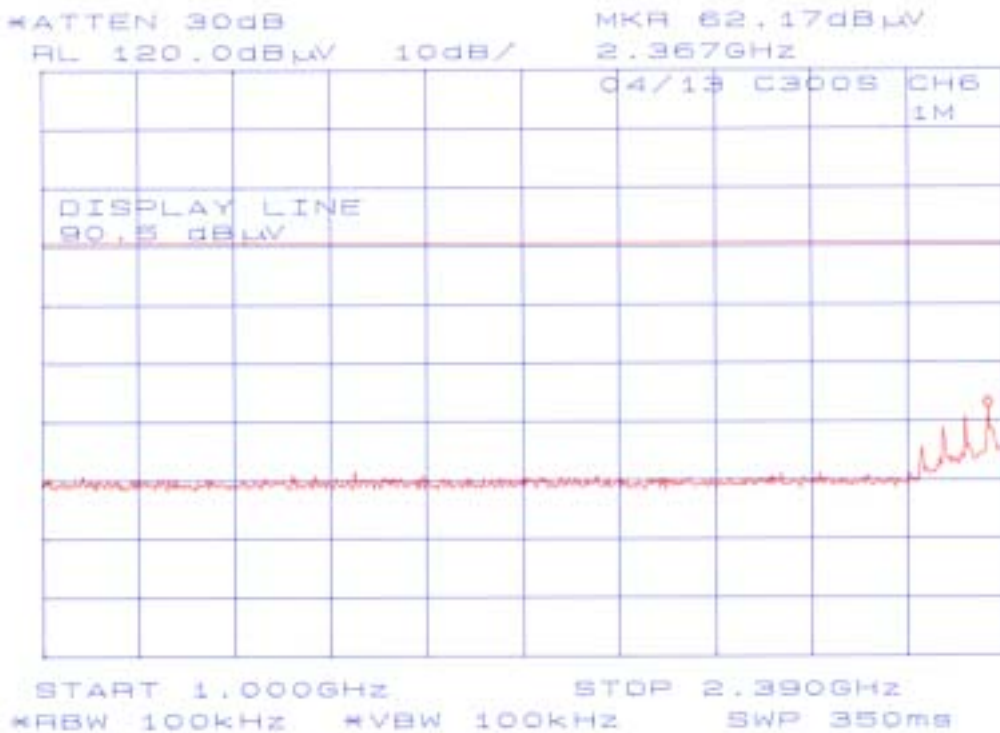
**Chart of CH1 with 1Mbps (25GHz-40GHz)**



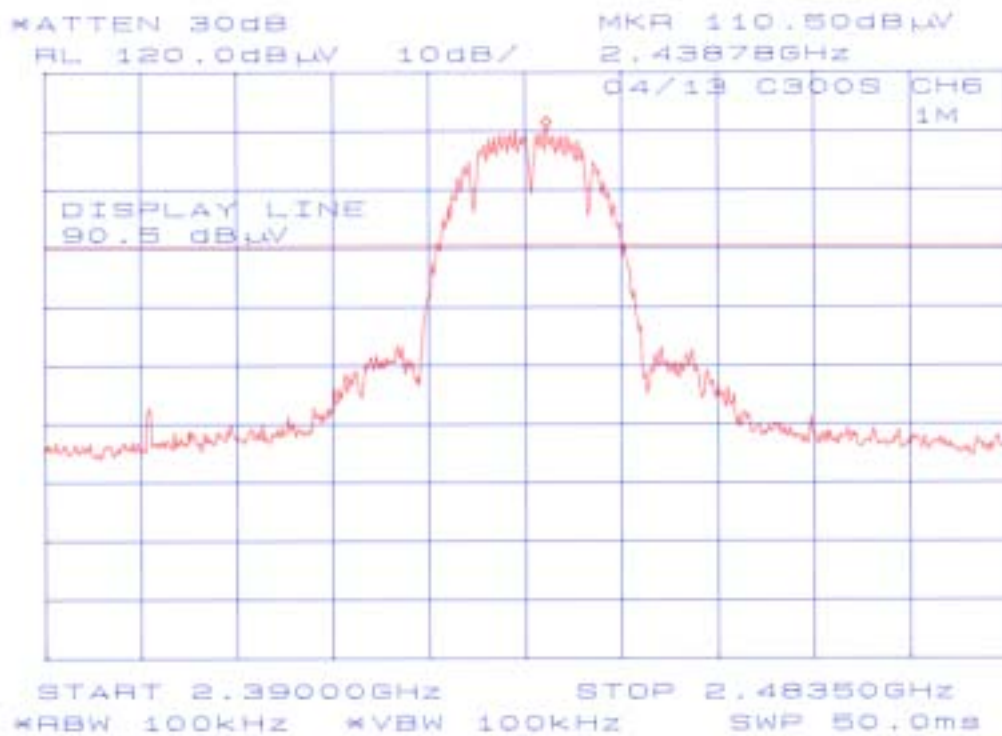
**Chart of CH6 with 1Mbps (1MHz-1GHz)**



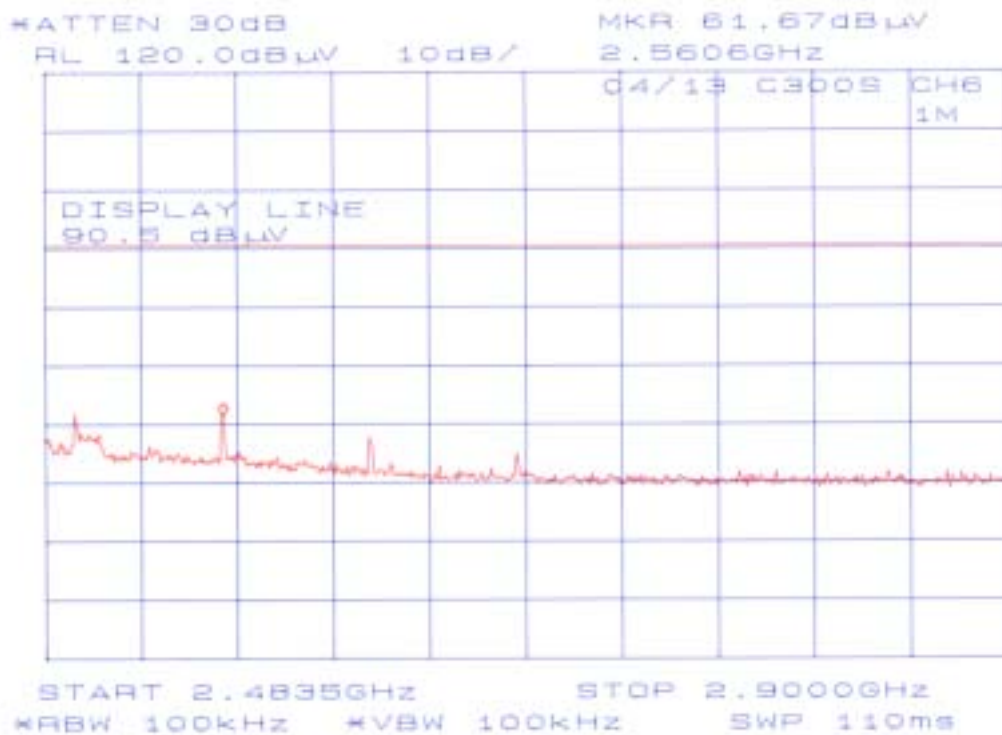
**Chart of CH6 with 1Mbps (1GHz-2.390GHz)**



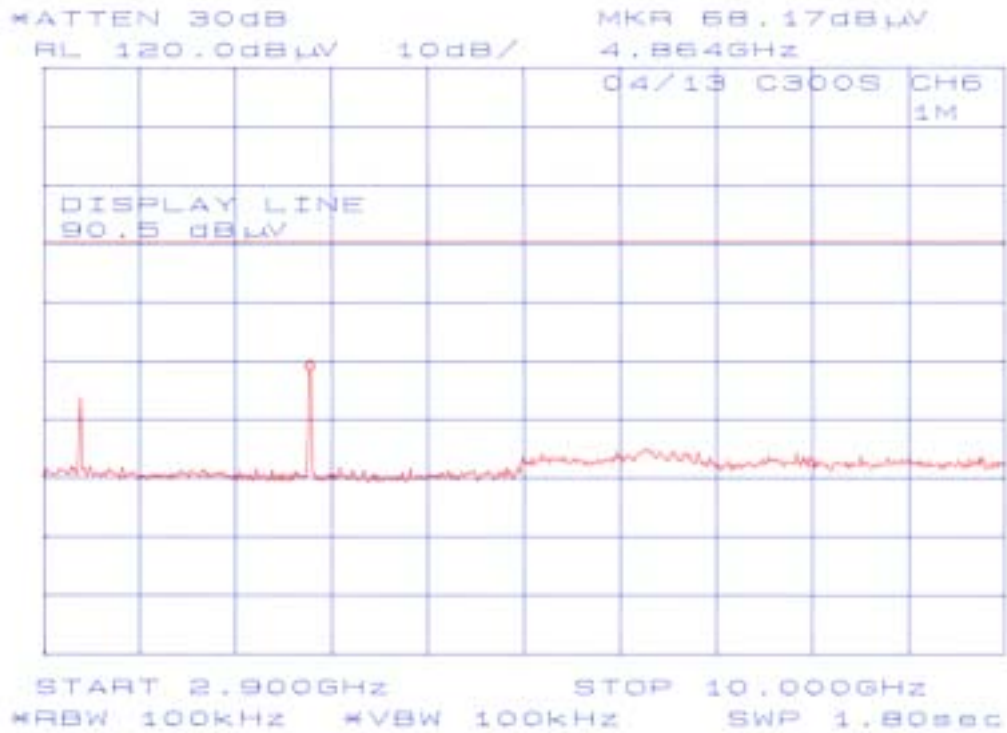
**Chart of CH6 with 1Mbps (2.390GHz-2.4835GHz)**



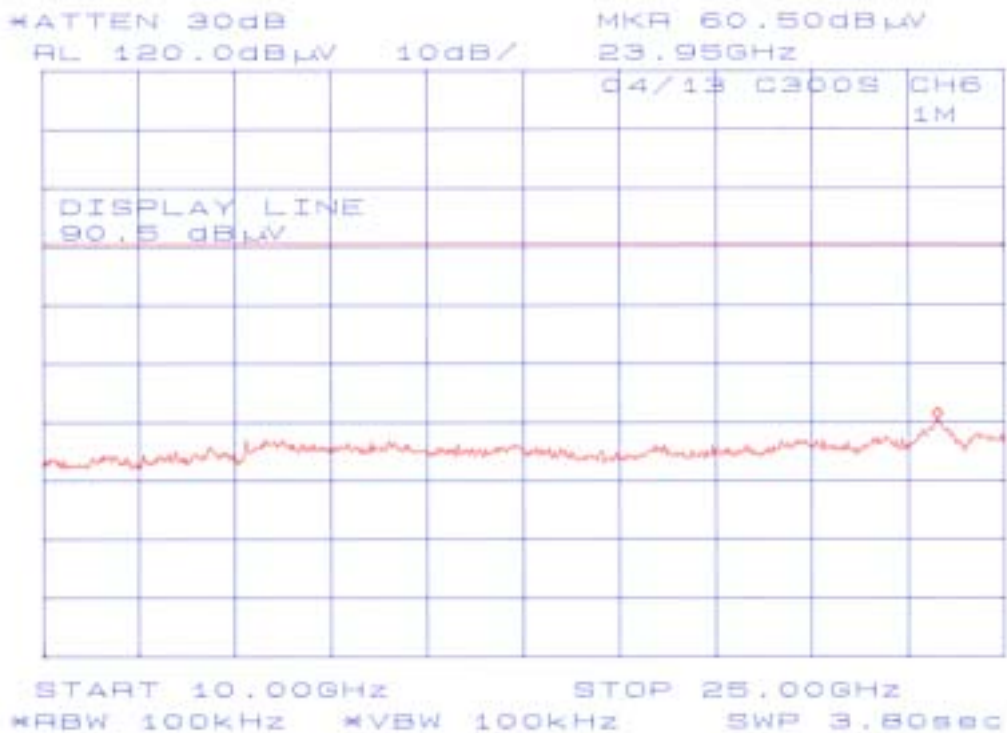
**Chart of CH6 with 1Mbps (2.4835GHz-2.9GHz)**



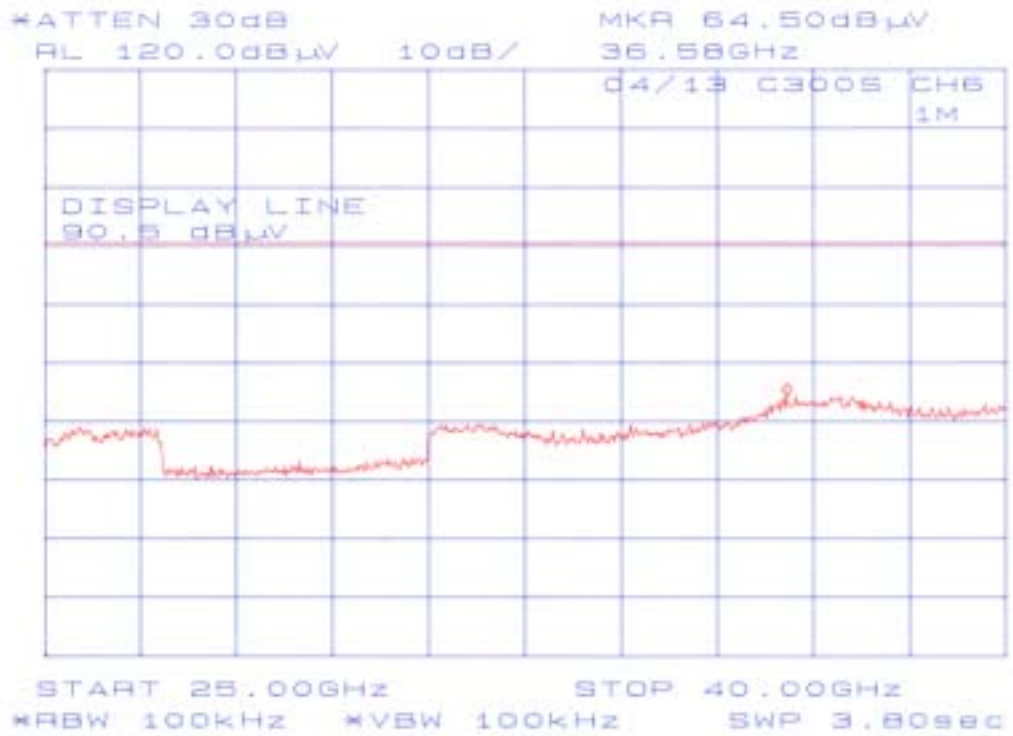
**Chart of CH6 with 1Mbps (2.9GHz-10GHz)**



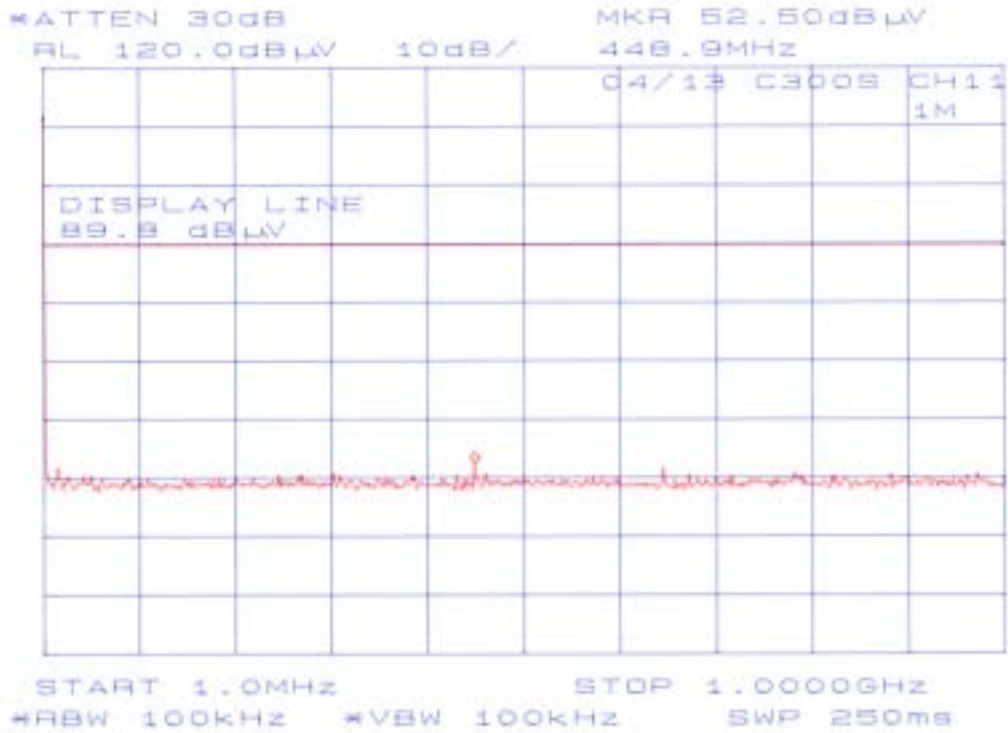
**Chart of CH6 with 1Mbps (10GHz-25GHz)**



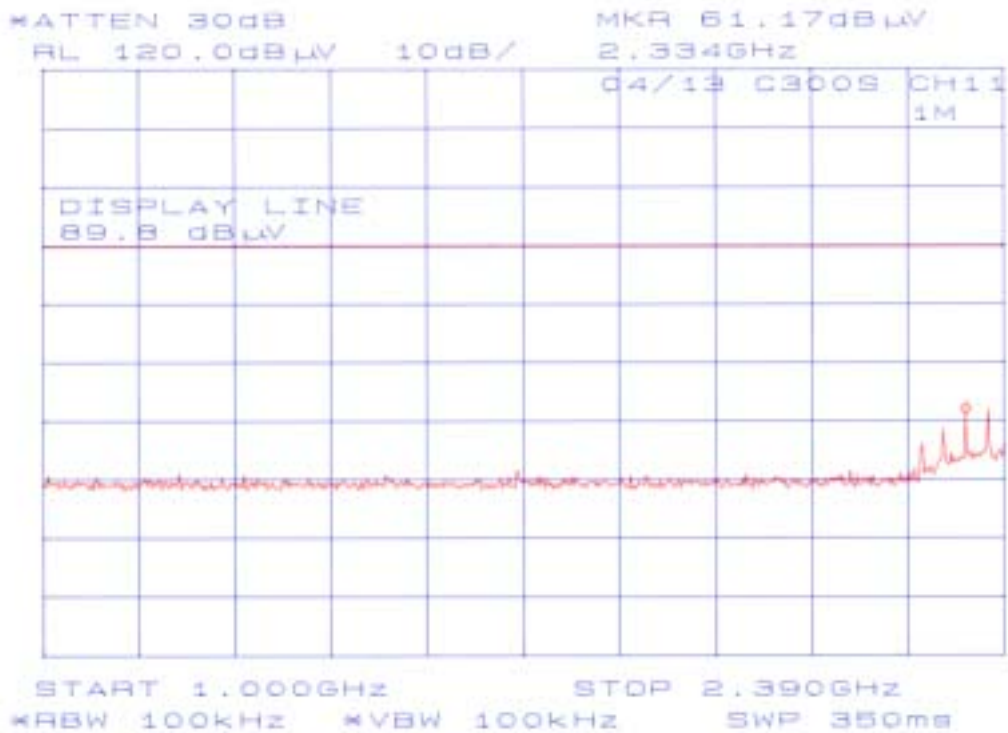
**Chart of CH6 with 1Mbps (25GHz-40GHz)**



**Chart of CH11 with 1Mbps (1MHz-1GHz)**

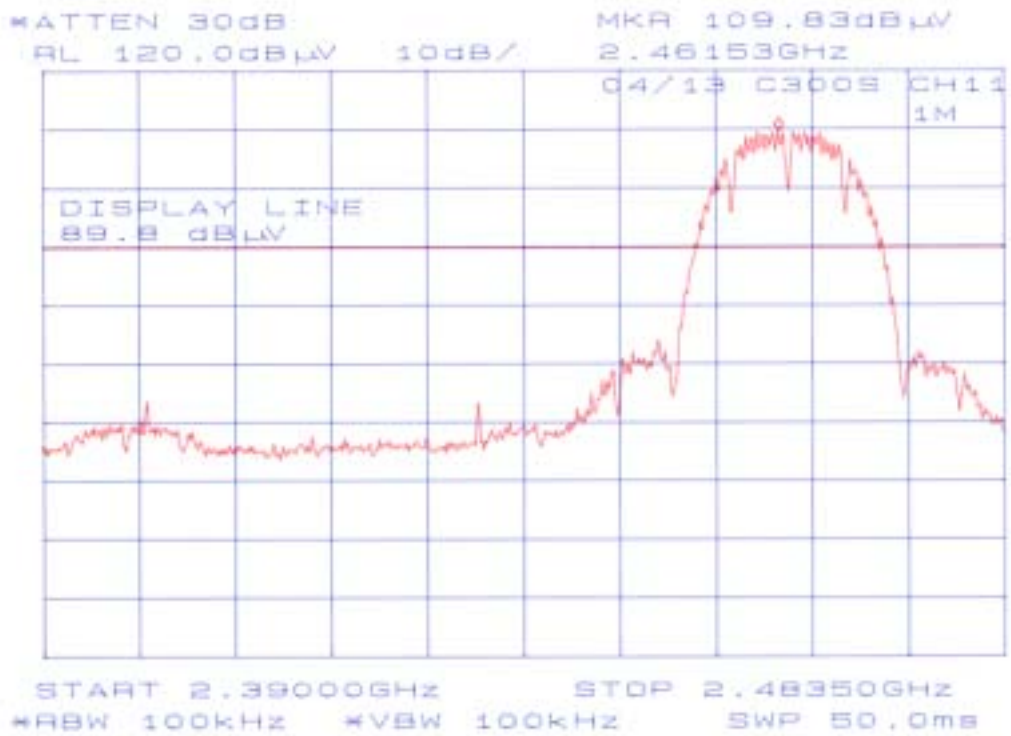


**Chart of CH11 with 1Mbps (1GHz-2.390GHz)**

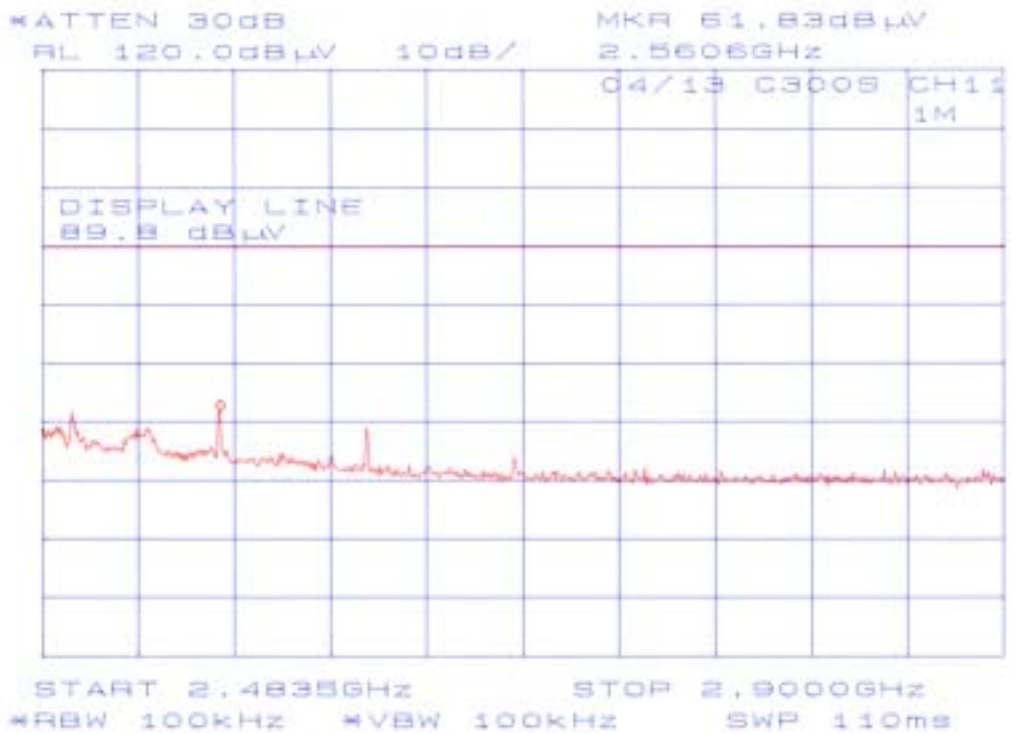




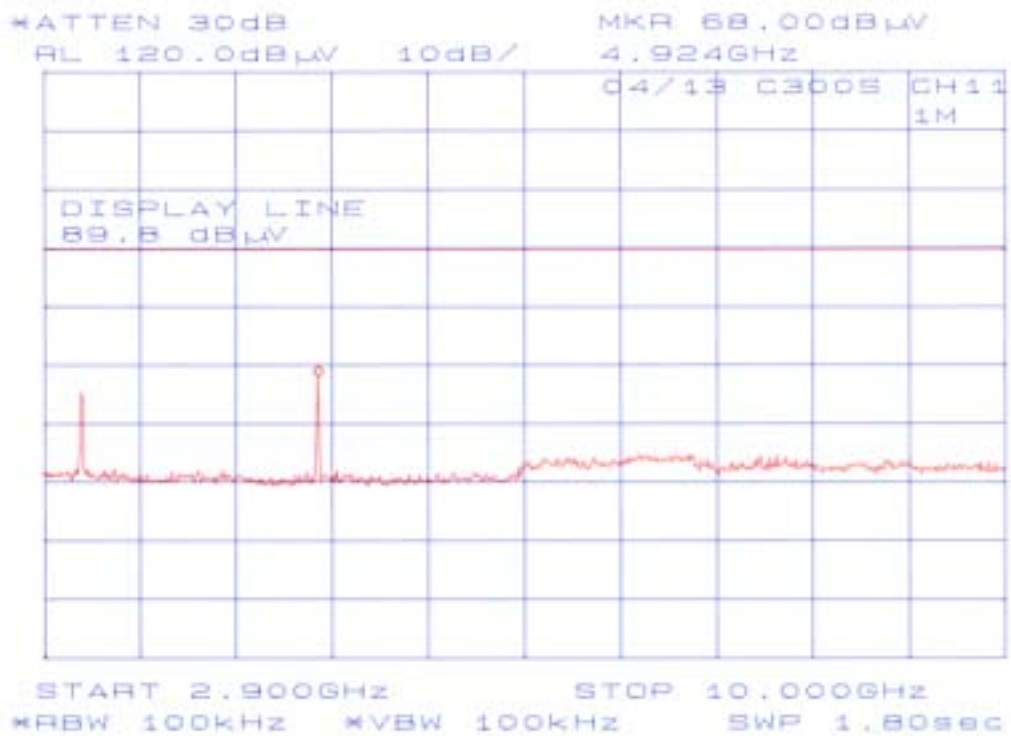
**Chart of CH11 with 1Mbps (2.390GHz-2.4835GHz)**



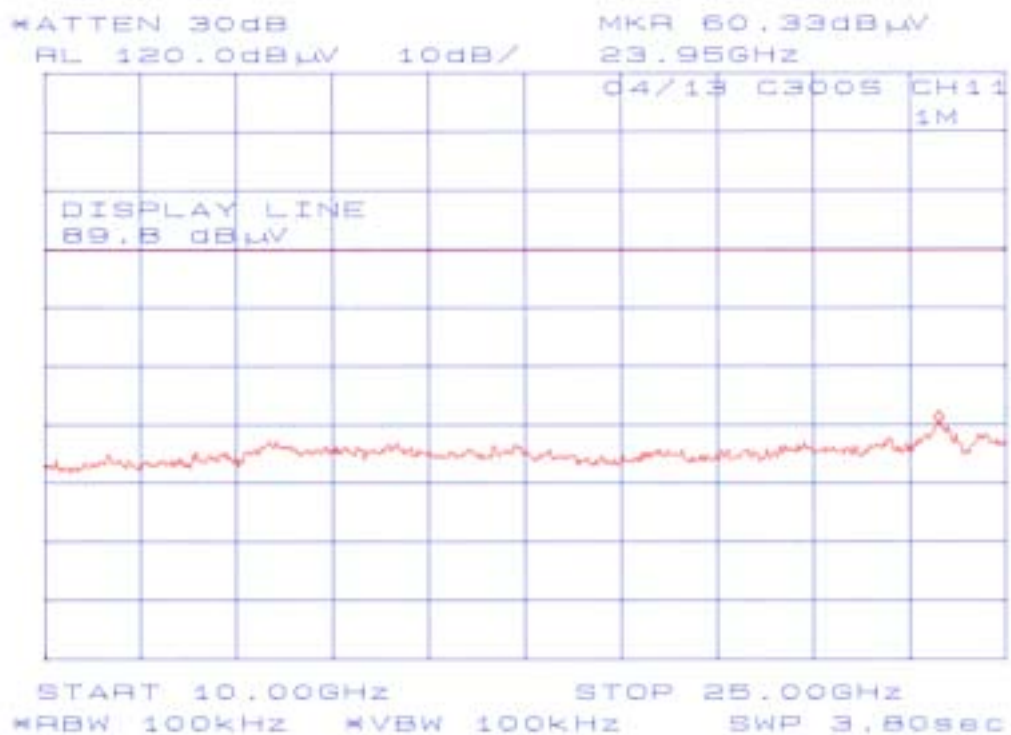
**Chart of CH11 with 1Mbps (2.4835GHz-2.9GHz)**



**Chart of CH11 with 1Mbps (2.9GHz-10GHz)**

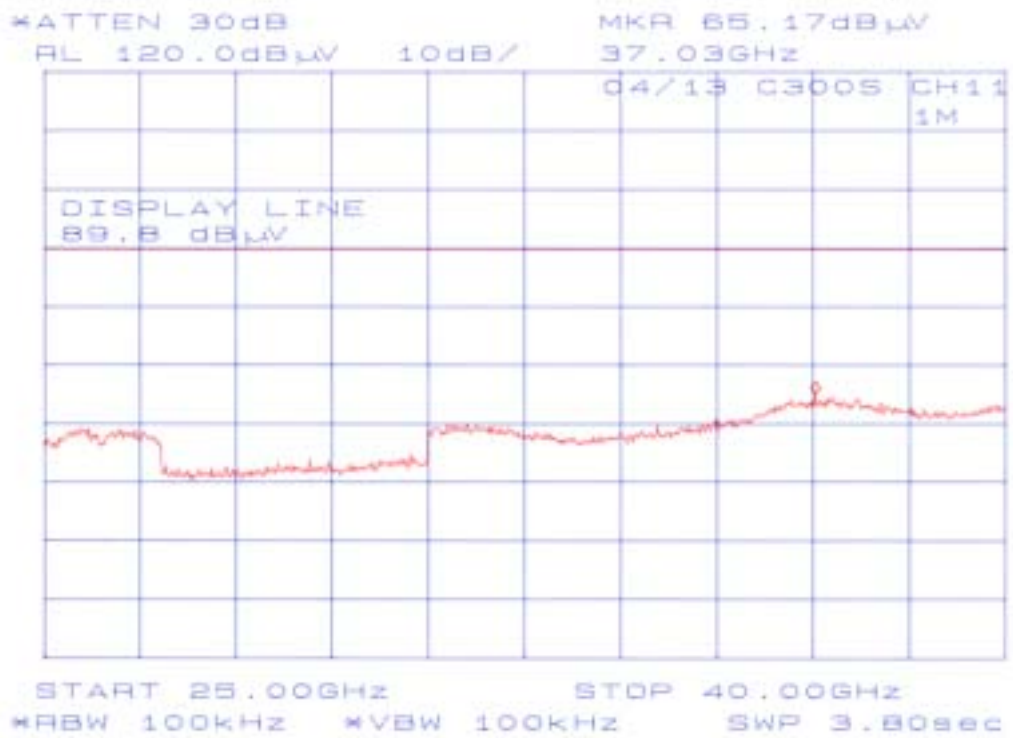


**Chart of CH11 with 1Mbps (10GHz-25GHz)**





**Chart of CH11 with 1Mbps (25GHz-40GHz)**

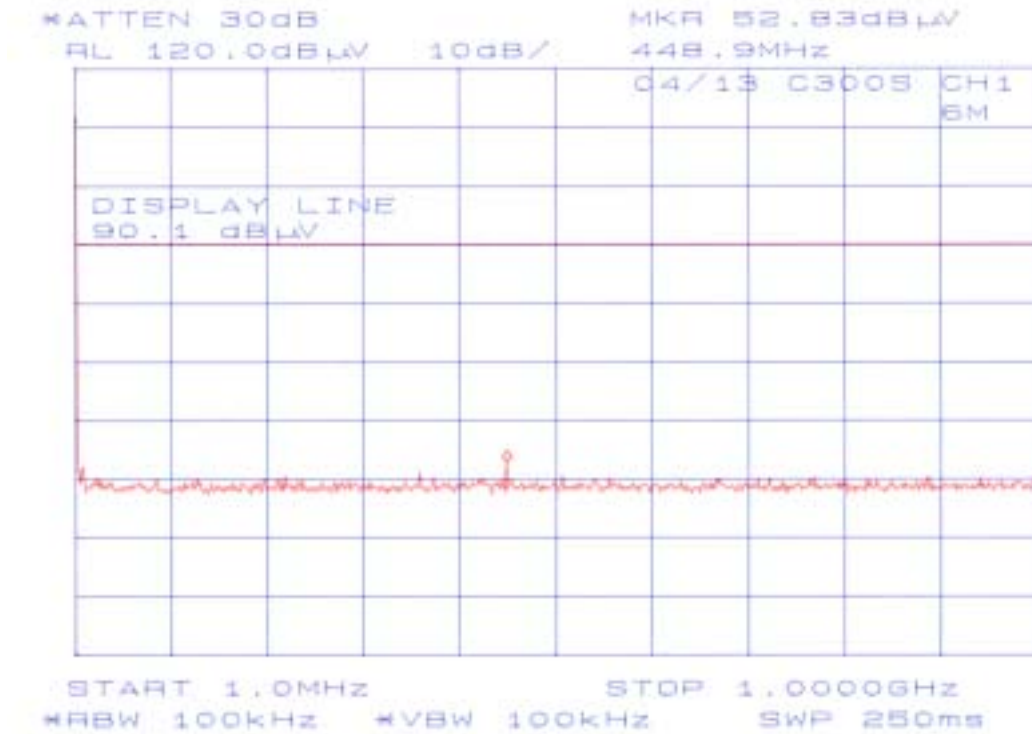


## **Annex B**

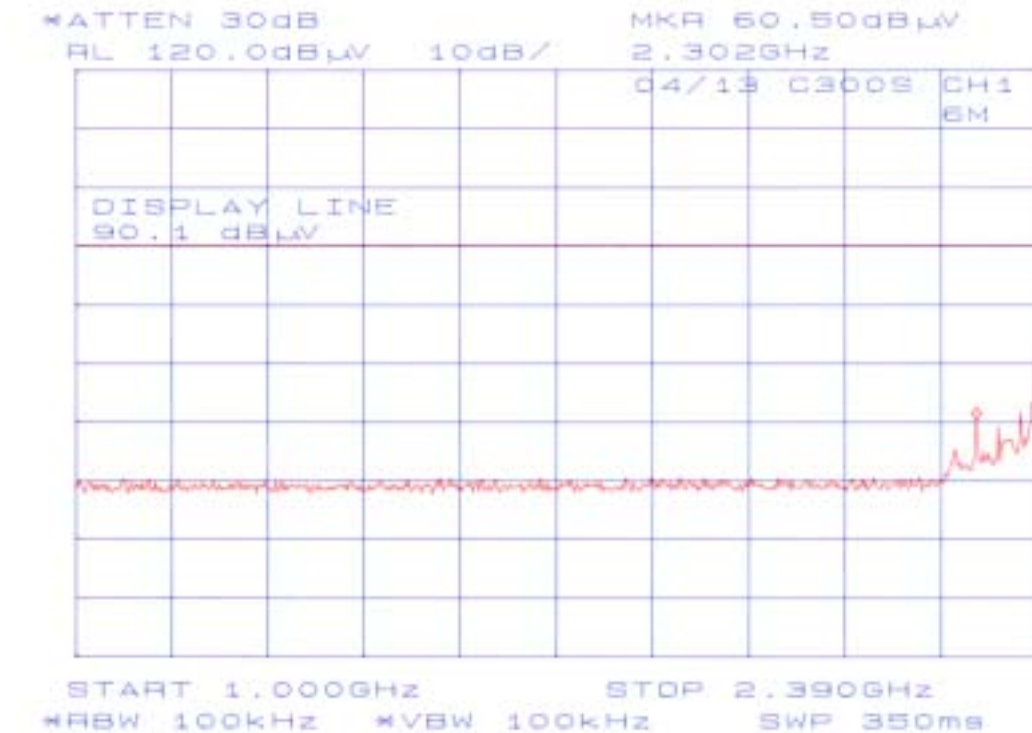
### **Spurious Emissions – RF Antenna Conducted Test**

**Modulation Method : 2.4GHz OFDM  
(Test mode)**

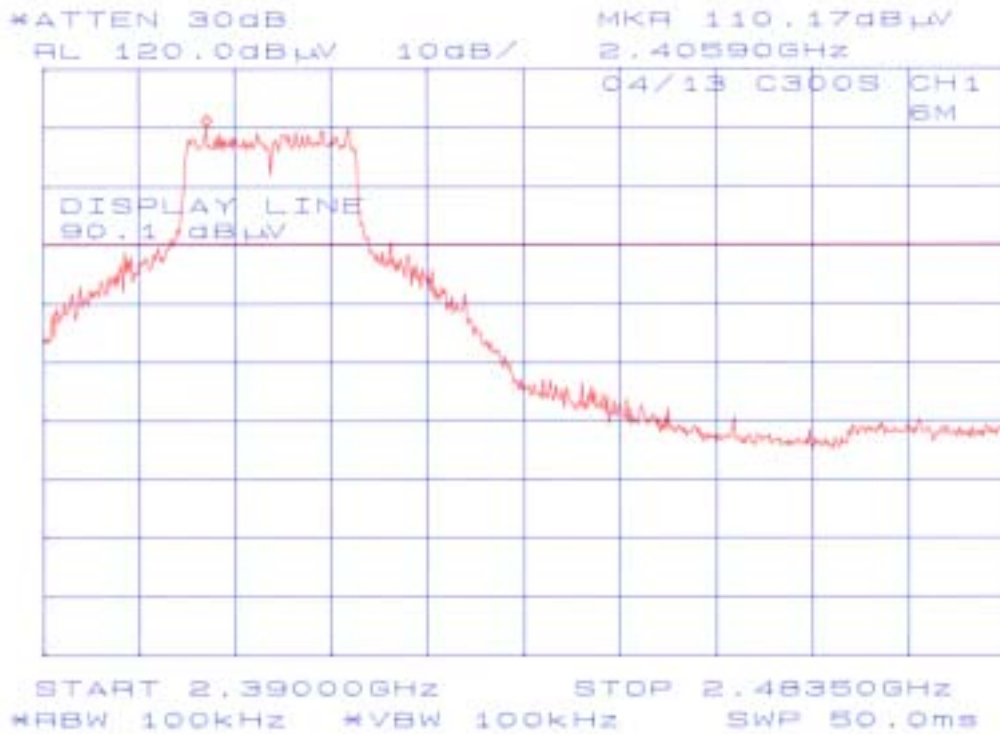
**Chart of CH1 with 6Mbps (1MHz-1GHz)**



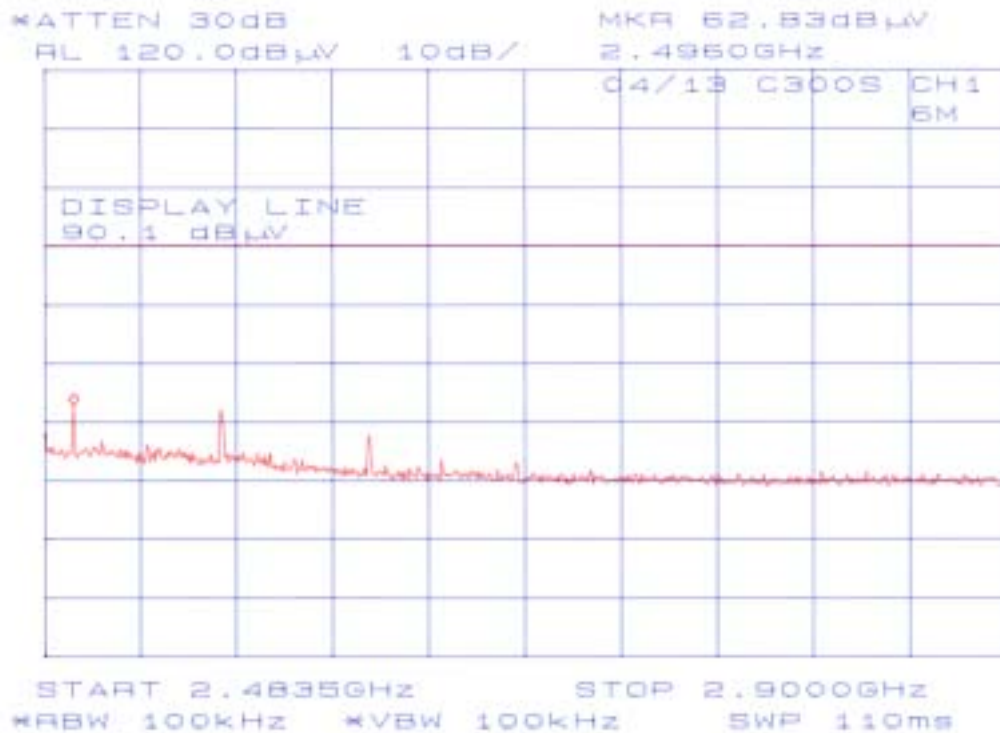
**Chart of CH1 with 6Mbps (1GHz-2.390GHz)**



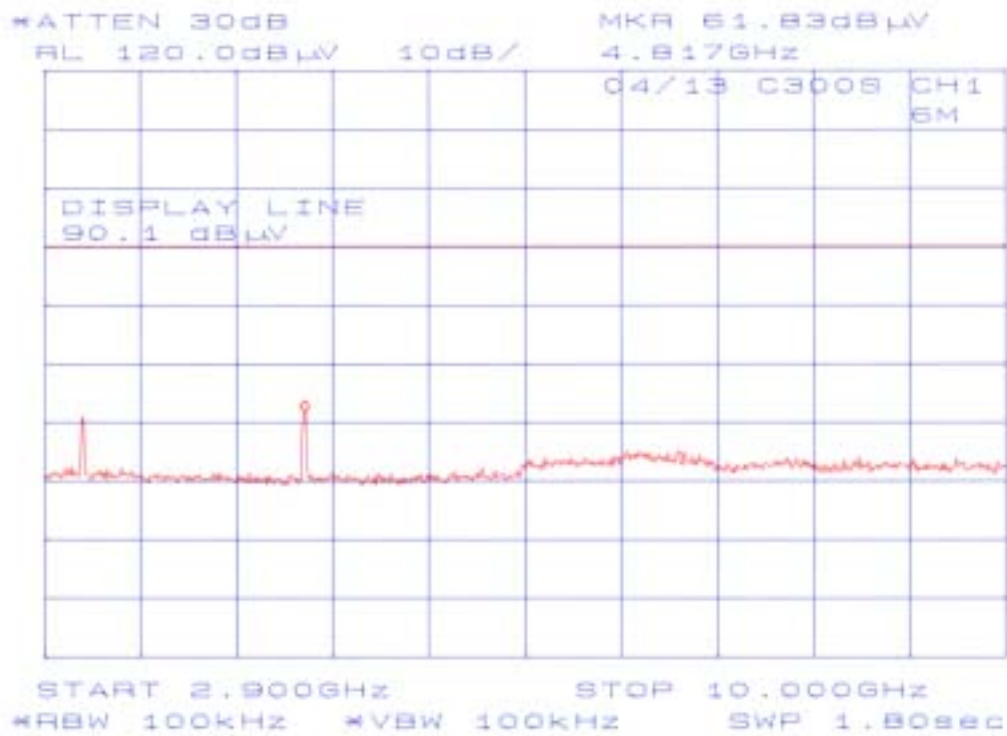
**Chart of CH1 with 6Mbps (2.390GHz-2.4835GHz)**



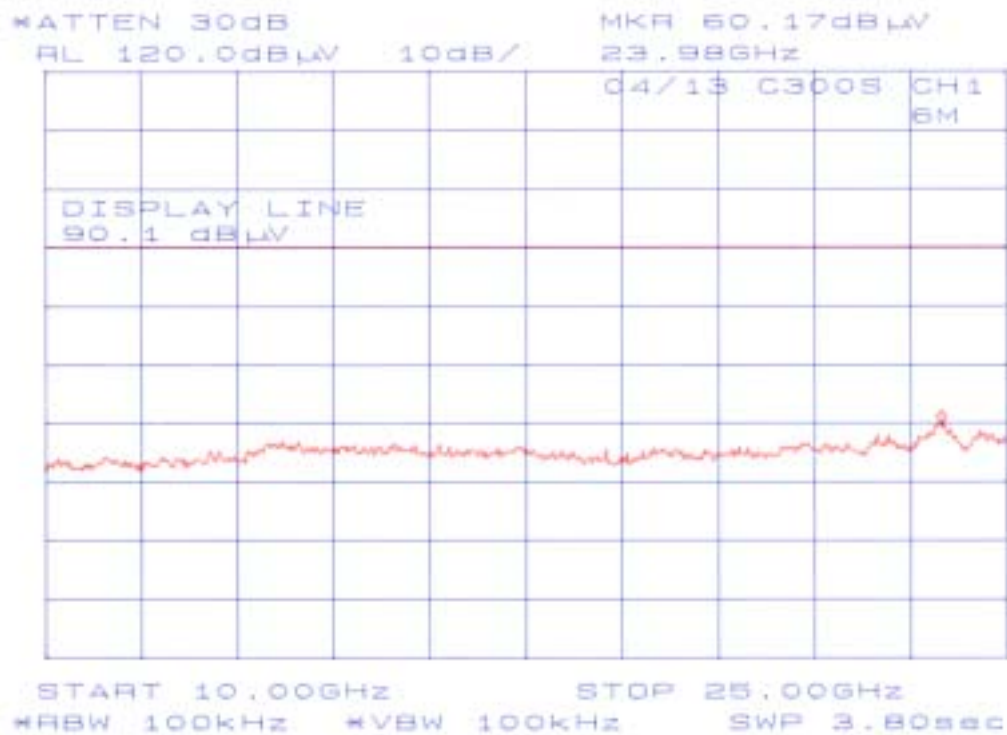
**Chart of CH1 with 6Mbps (2.4835GHz-2.9GHz)**



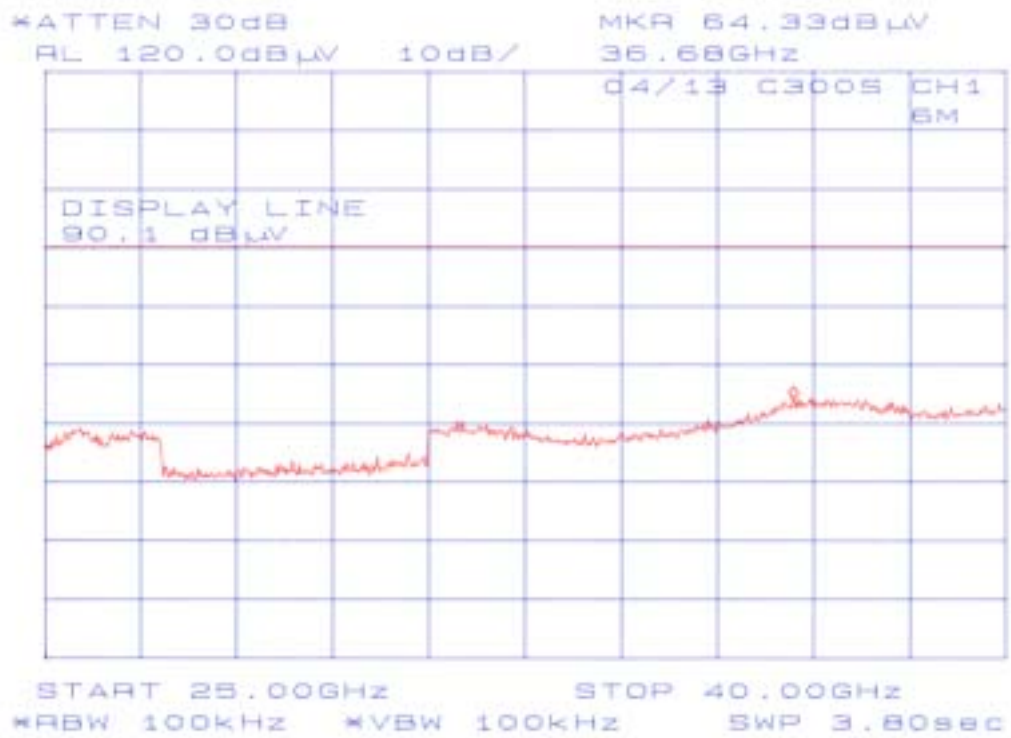
**Chart of CH1 with 6Mbps (2.9GHz-10GHz)**



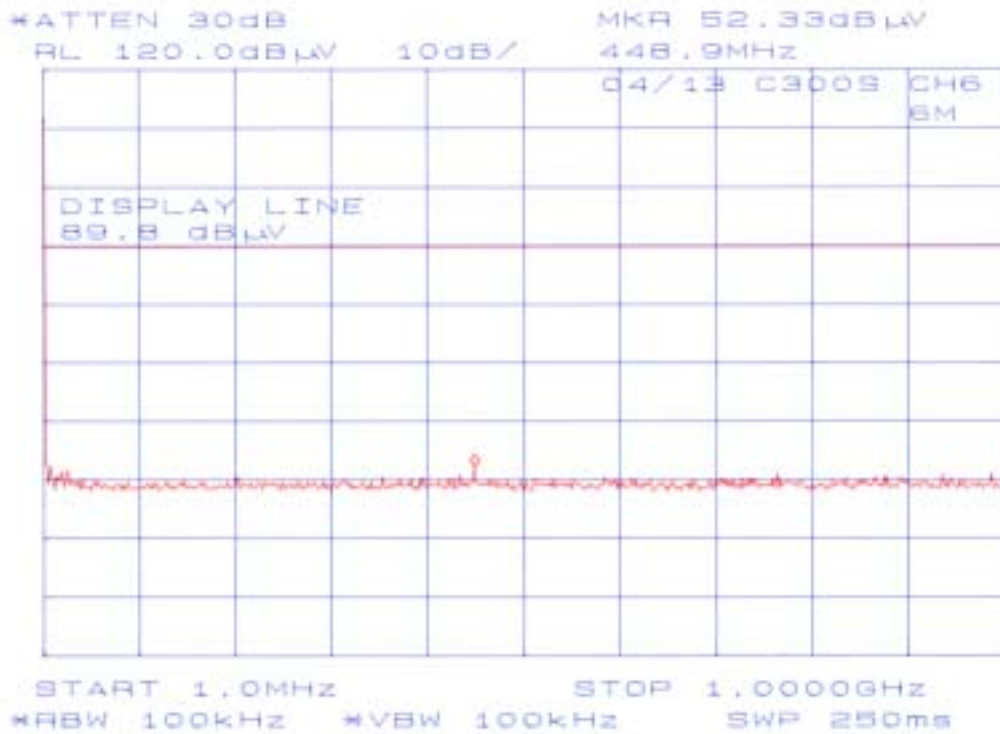
**Chart of CH1 with 6Mbps (10GHz-25GHz)**



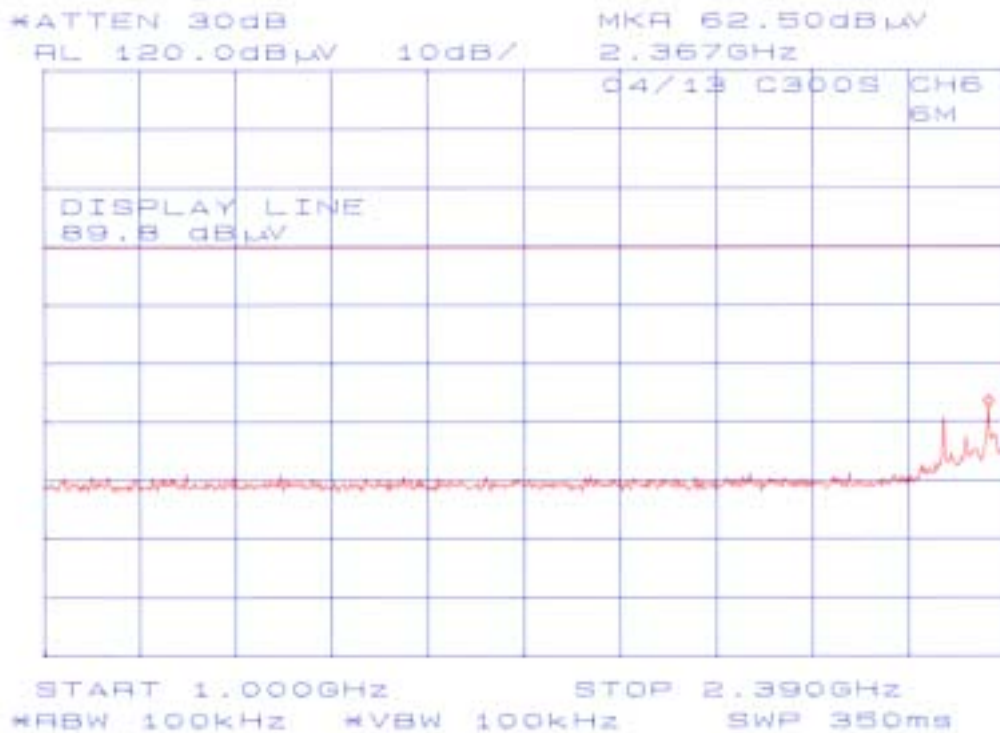
**Chart of CH1 with 6Mbps (25GHz-40GHz)**



**Chart of CH6 with 6Mbps (1MHz-1GHz)**

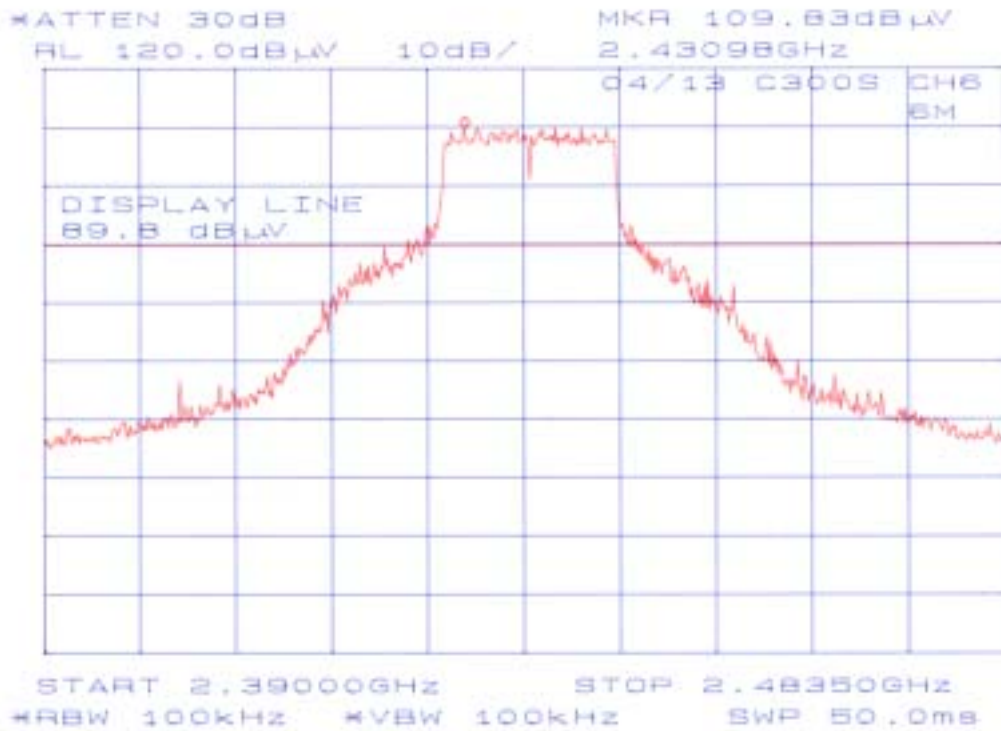


**Chart of CH6 with 6Mbps (1GHz-2.390GHz)**

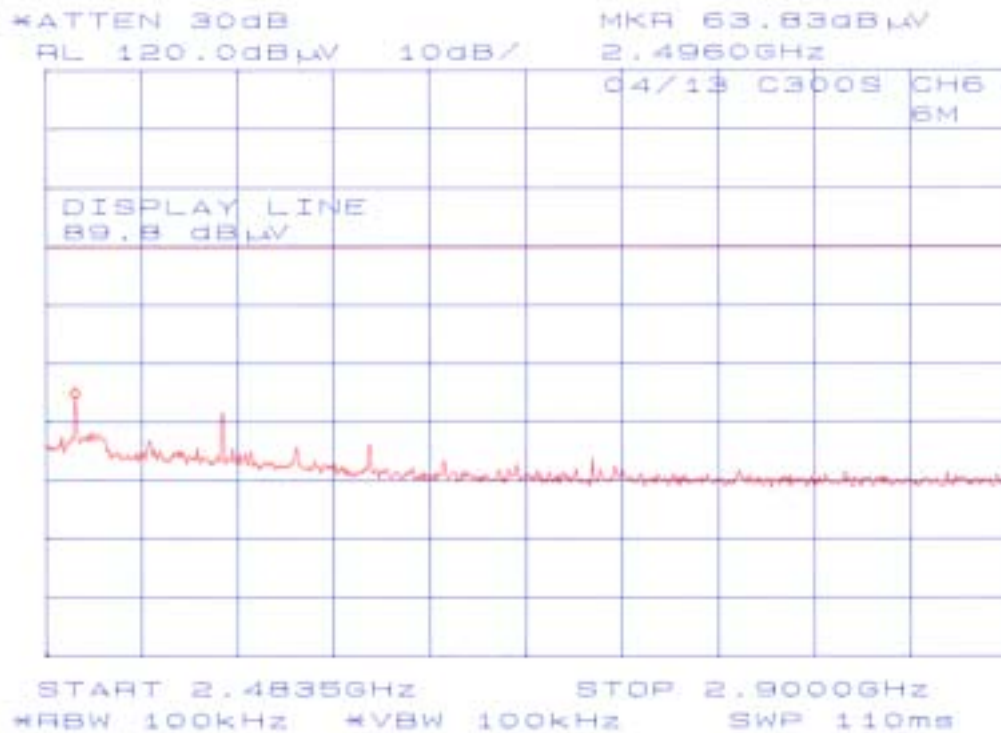




**Chart of CH6 with 6Mbps (2.390GHz-2.4835GHz)**

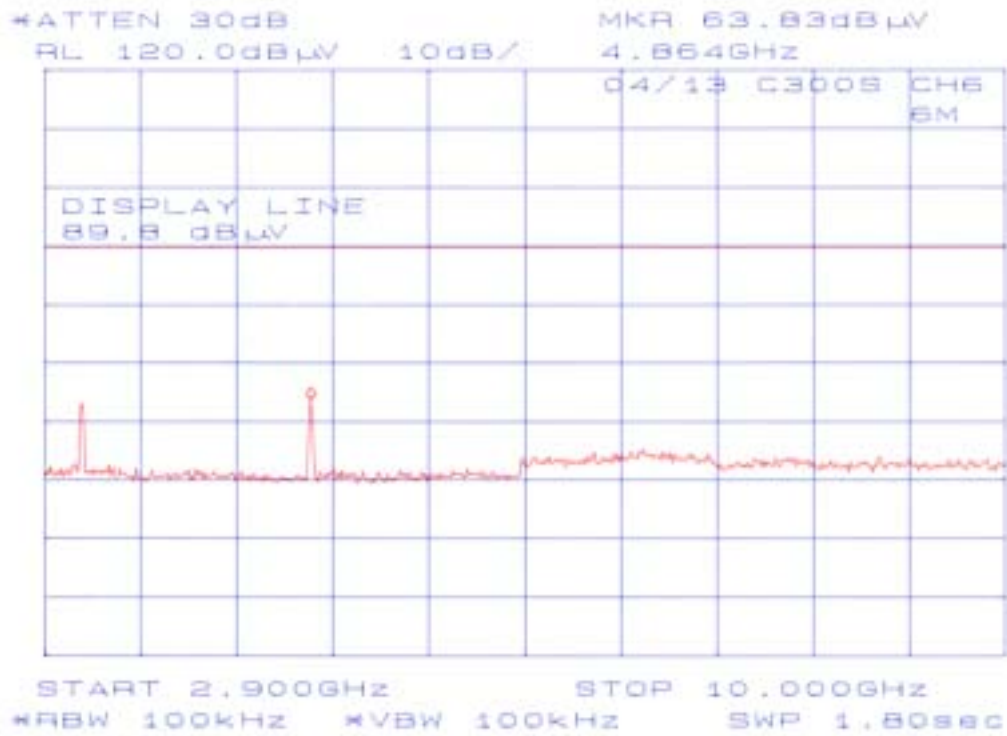


**Chart of CH6 with 6Mbps (2.4835GHz-2.9GHz)**

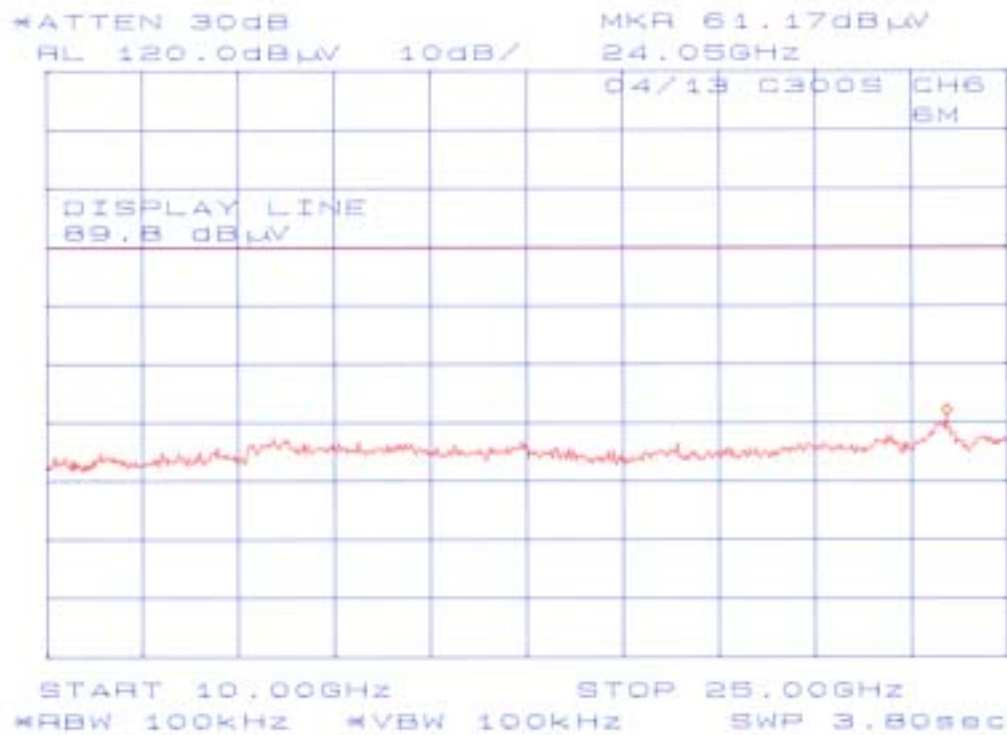




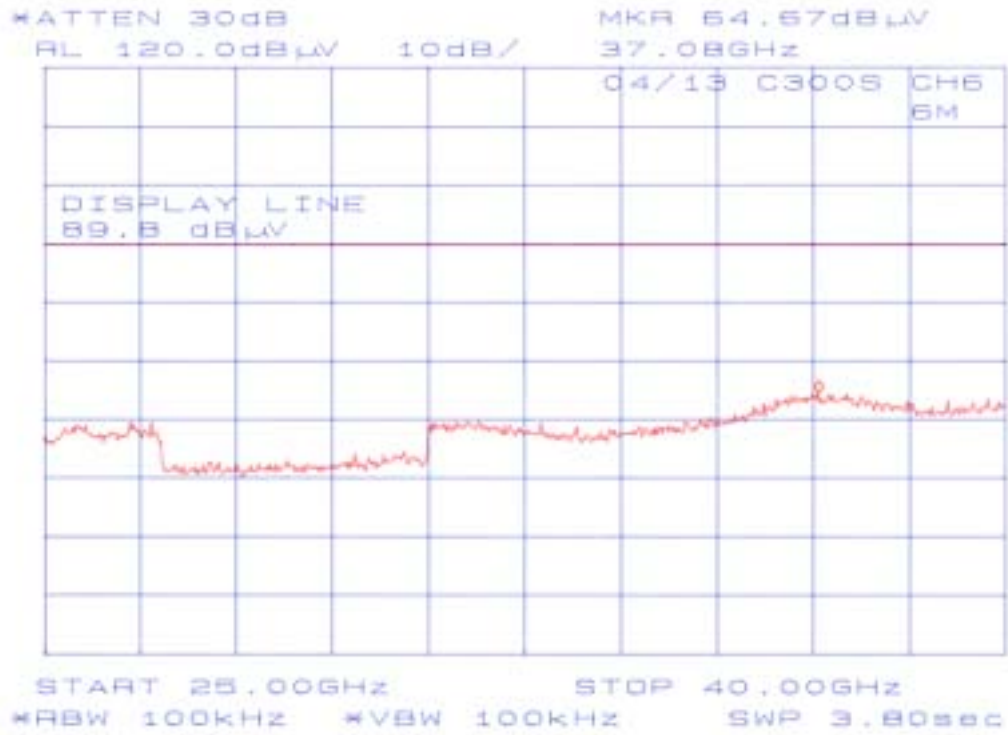
**Chart of CH6 with 6Mbps (2.9GHz-10GHz)**



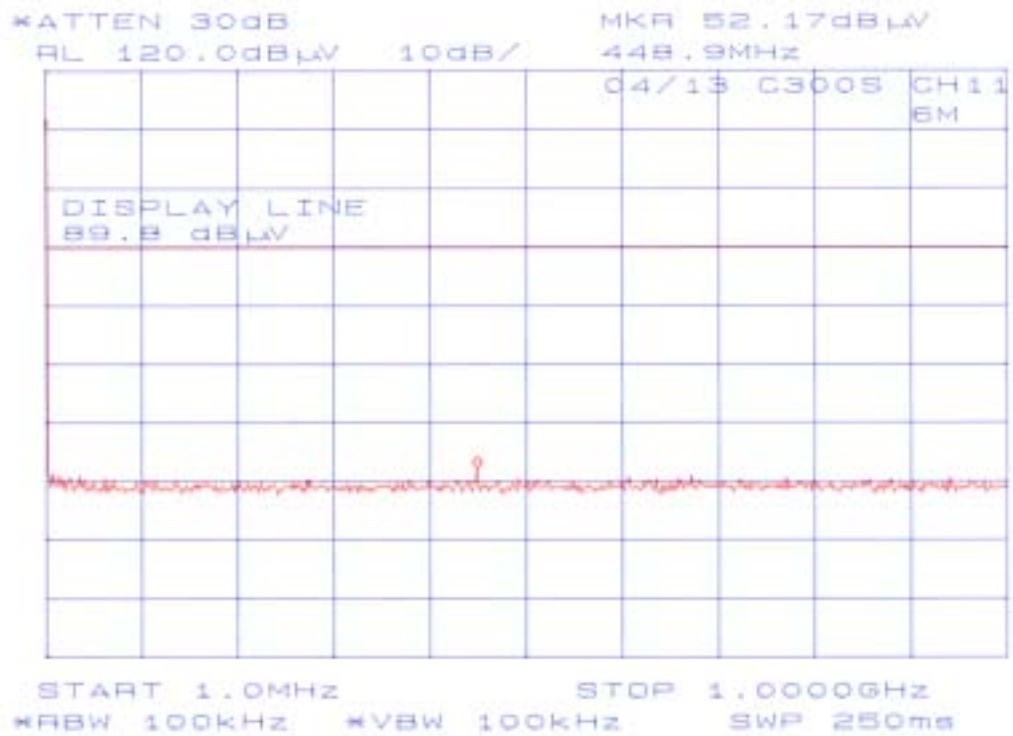
**Chart of CH6 with 6Mbps (10GHz-25GHz)**



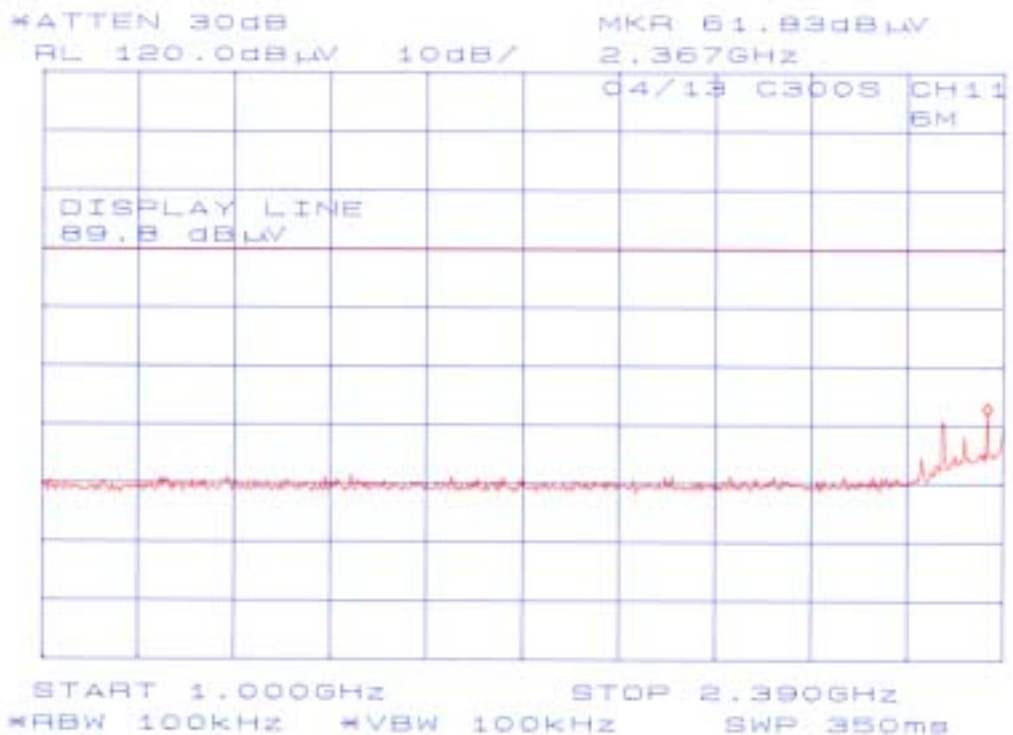
**Chart of CH6 with 6Mbps (25GHz-40GHz)**



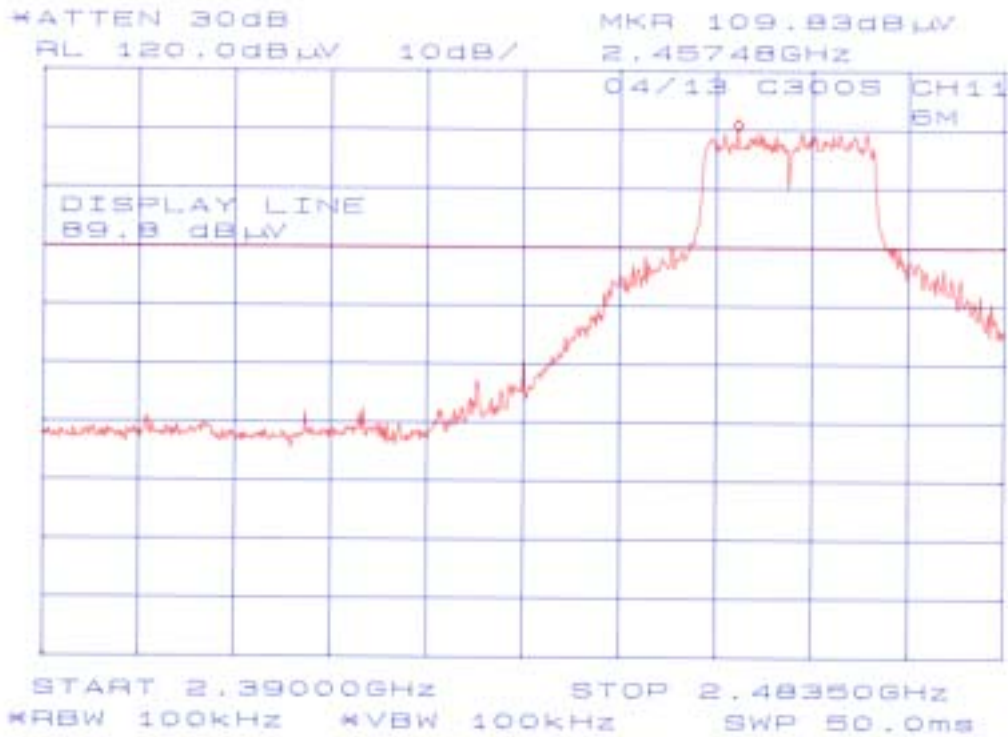
**Chart of CH11 with 6Mbps (1MHz-1GHz)**



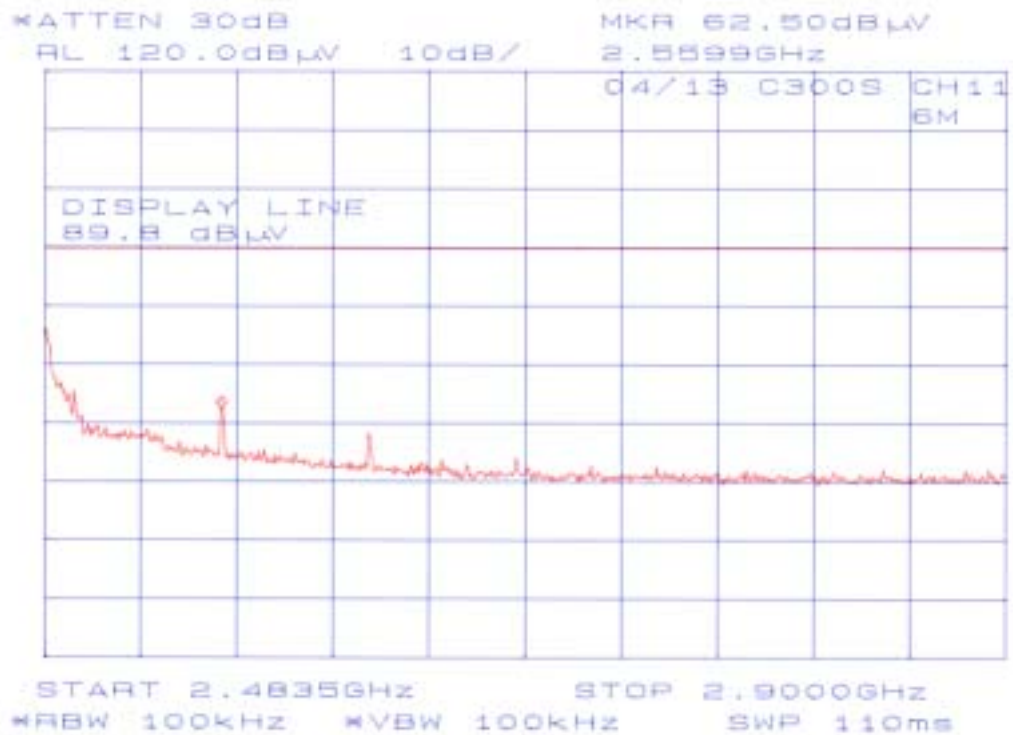
**Chart of CH11 with 6Mbps (1GHz-2.390GHz)**



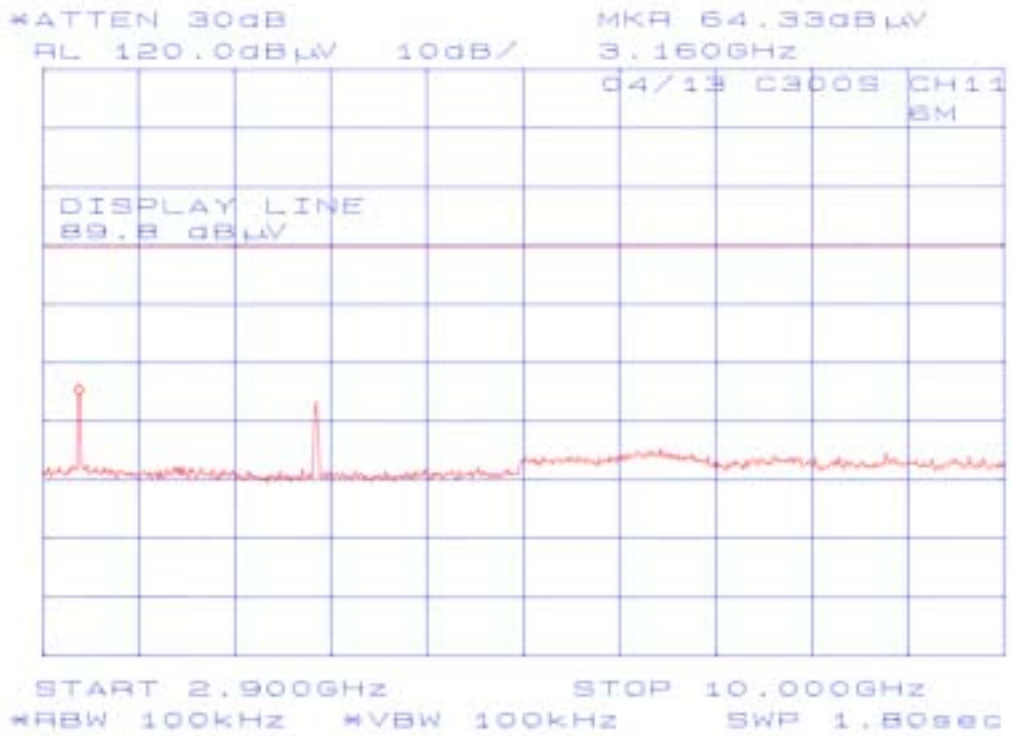
**Chart of CH11 with 6Mbps (2.390GHz-2.4835GHz)**



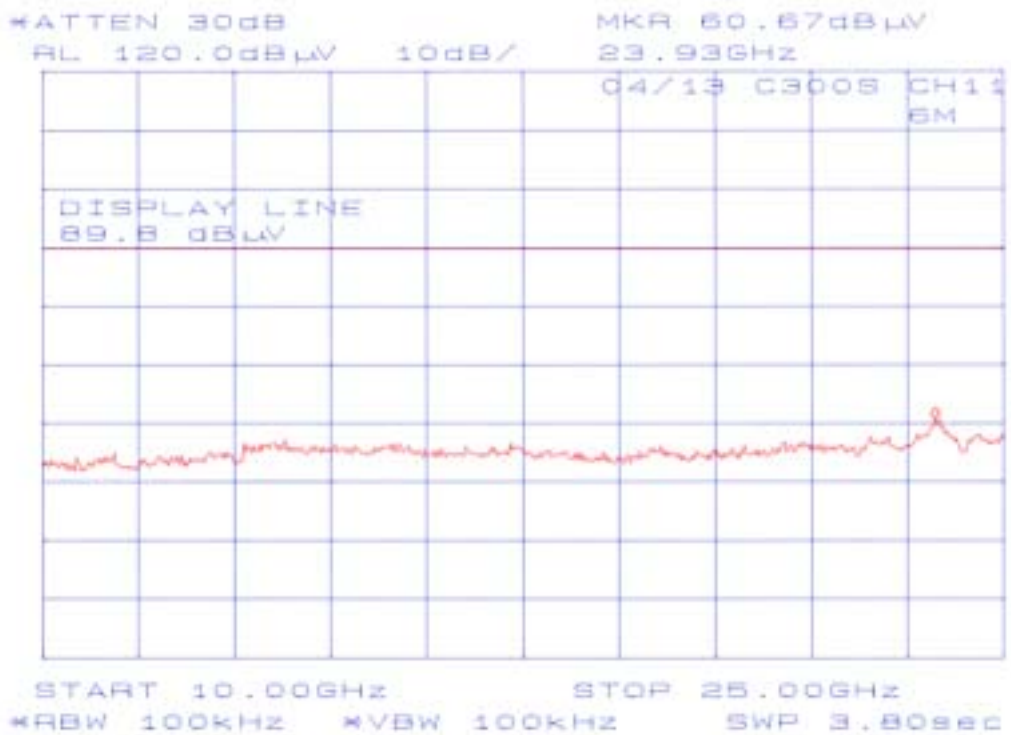
**Chart of CH11 with 6Mbps (2.4835GHz-2.9GHz)**



**Chart of CH11 with 6Mbps (2.9GHz-10GHz)**



**Chart of CH11 with 6Mbps (10GHz-25GHz)**



**Chart of CH11 with 6Mbps (25GHz-40GHz)**

