APPENDIX 2: SAR Measurement data

Appendix 2-1: Evaluation procedure

The SAR evaluation was performed with the following procedure:

Step 1: Measurement of the E-field at a fixed location above the central position of flat phantom was used as a reference value for assessing the power drop.

Step 2: The SAR distribution at the exposed side of head or body position was measured at a distance of each device from the inner surface of the shell. The area covered the entire dimension of the antenna of EUT and suitable horizontal grid spacing of EUT. Based on these data, the area of the maximum absorption was determined by splines interpolation.

Step 3: Around this point found in the Step 2 (area scan), a volume of more than or equal to 30mm(X axis)×30mm(Y axis)×30mm(Z axis) was assessed by measuring 7×7×7 points (or more) under 3GHz and a volume of more than or equal to 28mm(X axis)×28mm(Y axis)×24mm (Z axis) was assessed by measuring 8×8×7 (ratio step method (*1)) points (or more) for 3-6GHz frequency band.

Any additional peaks found in the Step2 which are within 2dB of limit are repeated with this Step3 (Zoom scan). On the basis of this data set, the spatial peak SAR value was evaluated under the following procedure:

- (1) The data at the surface were extrapolated, since the center of the dipoles is 1mm away from the tip of the probe and the distance between the surface and the lowest measuring point is 2mm. The extrapolation was based on a least square algorithm. A polynomial of the fourth order was calculated through the points in z-axes. This polynomial was then used to evaluate the points between the surface and the probe tip.
- (2) The maximum interpolated value was searched with a straightforward algorithm. Around this maximum the SAR values averaged over the spatial volumes (1g or 10g) were computed by the 3D-Spline interpolation algorithm. The 3D-Spline is composed of three one-dimensional splines with the "Not a knot"-condition (in x, y and z-directions). The volume was integrated with the trapezoidal-algorithm. One thousand points (10×10×10) were interpolated to calculate the average.
- (3) All neighboring volumes were evaluated until no neighboring volume with a higher average value was found.

Step 4: Re-measurement of the E-field at the same location as in Step 1 for the assessment of the power drift.

Step 5: Repeat Step 1-Step 4 with other condition or/and setup of EUT.

*1. Ratio step method parameters used; the first measurement point: "1.4mm" from the phantom surface, the initial grid separation: "1.4mm", subsequent graded grid ratio: "1.4". These parameters comply with the requirement of the KDB 865664 D01 (v01r04) and recommended by Schmid & Partner Engineering AG (DASY5 manual).

Appendix 2-2: SAR measurement data

Worst Reported SAR(1g) Plot

Plot 1-1: Front-tilt (No microphone) &gap=4mm / EDR(2DH5), 2441 MHz->Highest reported SAR(1g)

EUT: Helmet Mounted Wireless Headset; Type: NYSNO-10; Serial: 5002401

Mode: Bluetooth (fixed frequency, EDR, 2DH5) (UID: 0, Frame Length in ms: 0; PAR: 0; PMF: 1); **Frequency: 2441 MHz; Crest Factor: 1.0**
Medium: HSL2450(1711); Medium parameters used: f = 2441 MHz; $\sigma = 1.847$ S/m; $\epsilon_r = 37.60$; $\rho = 1000$ kg/m³

Measurement Standard: DASYS5 (IEEE/IEC/ANSI C63.19-2007)

DASY Configuration: -Probe: EX3DV4 - SN3907; ConvF(7.37, 7.37, 7.37); Calibrated: 2017/02/27; -DASY52 52.8.8(1222); SEMCAD X 14.6.10(7331)
-Sensor-Surface: 2mm (Mechanical Surface Detection), z = 1.0, 31.0, 186.0 -Electronics: DAE4 Sn554; Calibrated: 2017/05/18
-Phantom: SAM-Twin with CRP; Type: QD000P40CA; Serial: TP:1273; Phantom section: Left Section

helmet-mounted,no.mic/h19,2441,outer-ant-tilt&touch,edr(2dh5)/

Area:72x72,12 (7x7x1): Measurement grid: dx=12mm, dy=12mm; Maximum value of SAR (measured) = 0.973 W/kg

Area:72x72,12 (61x61x1): Interpolated grid: dx=1.200 mm, dy=1.200 mm; Maximum value of SAR (interpolated) = 1.21 W/kg

Z:185,5 (1x1x38): Measurement grid: dx=20mm, dy=20mm, dz=5mm; Maximum value of SAR (measured) = 1.07 W/kg

Zoom:30x30x30,5 (7x7x7)/Cube 0: Measurement grid: dx=5mm, dy=5mm, dz=5mm;

Reference Value = 23.18 V/m; Power Drift = -0.07 dB; Maximum value of SAR (measured) = 1.07 W/kg; Peak SAR (extrapolated) = 1.46 W/kg

SAR(1 g) = 0.733 W/kg; SAR(10 g) = 0.367 W/kg

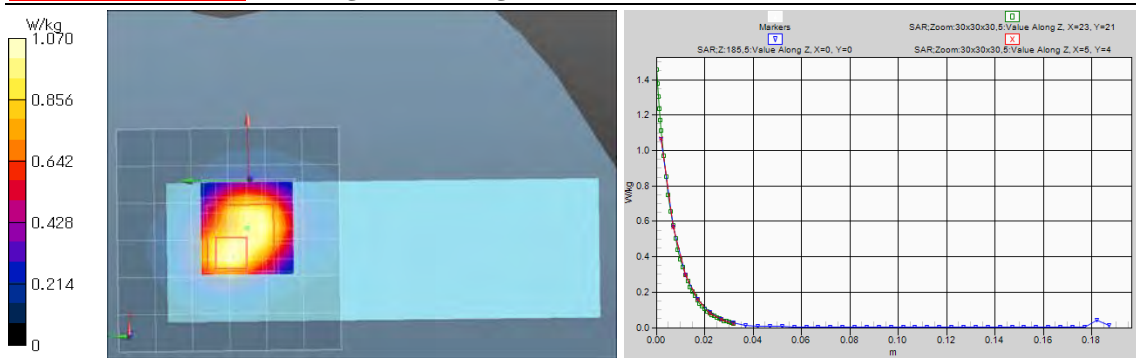

Remarks: * Date tested: 2017/11/14, Tested by: Hiroshi Naka; Tested place:No.7 shielded room,
* liquid depth: 183 mm (*Flat); Position: distance of EUT to phantom: 0 mm (2 mm to liquid); ambient: (24~25) deg.C. / (40~50) %RH,
* liquid temperature: 23.9(start)/24.0(end)/24.0(in check) deg.C.; * White cubic: zoom scan area, Red cubic: big=SAR(10g)/small=SAR(1g)

Plot 1-2: Back (With microphone) &gap=4mm / EDR(2DH5), 2441 MHz->Higher reported SAR(1g), with microphone

EUT: Helmet Mounted Wireless Headset; Type: NYSNO-10; Serial: 5002401

Mode: Bluetooth (fixed frequency, EDR, 2DH5) (UID: 0, Frame Length in ms: 0; PAR: 0; PMF: 1); **Frequency: 2441 MHz; Crest Factor: 1.0**
Medium: HSL2450(1711); Medium parameters used: f = 2441 MHz; $\sigma = 1.842$ S/m; $\epsilon_r = 37.89$; $\rho = 1000$ kg/m³

Measurement Standard: DASYS5 (IEEE/IEC/ANSI C63.19-2007)

DASY Configuration: -Probe: EX3DV4 - SN3907; ConvF(7.37, 7.37, 7.37); Calibrated: 2017/02/27; -DASY52 52.8.8(1222); SEMCAD X 14.6.10(7331)
-Sensor-Surface: 2mm (Mechanical Surface Detection), z = 1.0, 31.0, 161.0 -Electronics: DAE4 Sn554; Calibrated: 2017/05/18
-Phantom: SAM-Twin with CRP; Type: QD000P40CA; Serial: TP:1273; Phantom section: Left Section

helmet-mounted,sam-left/h3,2441,inner-ant-tilt2&d4mm,edr(2dh5)/

Area:72x72,12 (7x7x1): Measurement grid: dx=12mm, dy=12mm; Maximum value of SAR (measured) = 0.813 W/kg

Area:72x72,12 (61x61x1): Interpolated grid: dx=1.200 mm, dy=1.200 mm; Maximum value of SAR (interpolated) = 0.860 W/kg

Z:160,5 (1x1x33): Measurement grid: dx=20mm, dy=20mm, dz=5mm; Maximum value of SAR (measured) = 0.777 W/kg

Zoom:30x30x30,5 (7x7x7)/Cube 0: Measurement grid: dx=5mm, dy=5mm, dz=5mm;

Reference Value = 20.60 V/m; Power Drift = -0.04 dB; Maximum value of SAR (measured) = 0.944 W/kg; Peak SAR (extrapolated) = 1.21 W/kg

SAR(1 g) = 0.614 W/kg; SAR(10 g) = 0.310 W/kg

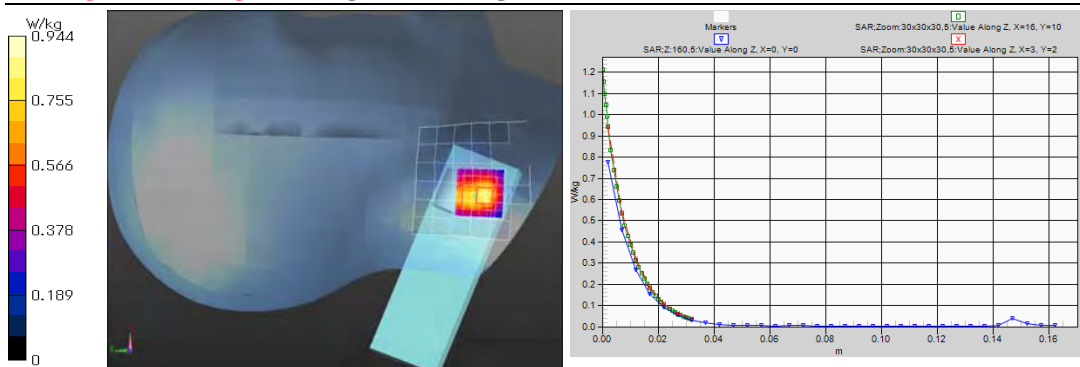

Remarks: * Date tested: 2017/11/10, Tested by: Hiroshi Naka; Tested place:No.7 shielded room,
* liquid depth: 153 mm (*LEFT ERP); Position: distance of EUT to phantom: 0 mm (2 mm to liquid); ambient: (24~25) deg.C. / (40~50) %RH,
* liquid temperature: 23.7(start)/23.7(end)/24.0(in check) deg.C.; * White cubic: zoom scan area, Red cubic: big=SAR(10g)/small=SAR(1g)

Appendix 2-2: SAR measurement data (cont'd)

Other SAR(1g) Plots

Plot 2-1: Back (With microphone) & gap=4mm / EDR(3DH5), 2441 MHz

EUT: Helmet Mounted Wireless Headset; Type: NYSNO-10; Serial: 5002401

Mode: Bluetooth (fixed frequency, EDR, 3DH5) (UID: 0, Frame Length in ms: 0; PAR: 0; PMF: 1); **Frequency: 2441 MHz; Crest Factor: 1.0**

Medium: HSL2450(1711); Medium parameters used: $f = 2441$ MHz; $\sigma = 1.842$ S/m; $\epsilon_r = 37.89$; $\rho = 1000$ kg/m³

Measurement Standard: DASY5 (IEEE/IEC/ANSI C63.19-2007)

DASY Configuration: -Probe: EX3DV4 - SN3907; ConvF(7.37, 7.37, 7.37); Calibrated: 2017/02/27; -DASY52 52.8.8(1222); SEMCAD X 14.6.10(7331)
-Sensor-Surface: 2mm (Mechanical Surface Detection), z = 1.0, 31.0 -Electronics: DAE4 Sn554; Calibrated: 2017/05/18
-Phantom: SAM-Twin with CRP; Type: QD000P40CA; Serial: TP:1273; Phantom section: Left Section

helmet-mounted,sam-left/h1,2441,inner-ant-tilt2&d4mm,edr(3dh5)

Area:72x72,12 (7x7x1): Measurement grid: dx=12mm, dy=12mm; Maximum value of SAR (measured) = 0.752 W/kg

Area:72x72,12 (61x61x1): Interpolated grid: dx=1.200 mm, dy=1.200 mm; Maximum value of SAR (interpolated) = 0.893 W/kg

Zoom:30x30x30,5 (8x8x7)/Cube 0: Measurement grid: dx=5mm, dy=5mm, dz=5mm;

Reference Value = 19.60 V/m; Power Drift = -0.04 dB; Maximum value of SAR (measured) = 0.759 W/kg; Peak SAR (extrapolated) = 1.07 W/kg

SAR(1 g) = 0.524 W/kg; SAR(10 g) = 0.283 W/kg

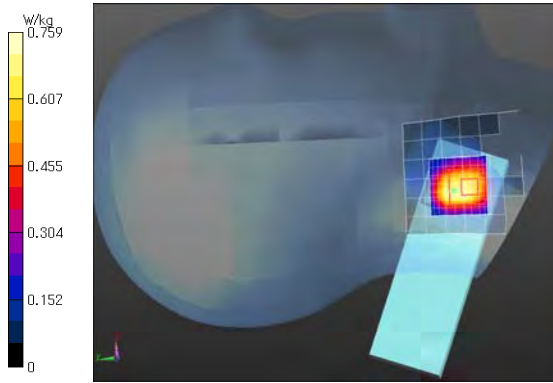

Remarks: * Date tested: 2017/11/10, Tested by: Hiroshi Naka; Tested place: No.7 shielded room,
* liquid depth: 153 mm (*LEFT ERP); Position: distance of EUT to phantom: 0 mm (2 mm to liquid); ambient: (24~25) deg.C. / (40~50) %RH,
* liquid temperature: 23.6(start)/23.6(end)/24.0(in check) deg.C.; * White cubic: zoom scan area, Red cubic: big=SAR(10g) / small=SAR(1g)

Plot 2-2: Back (With microphone) & gap=4mm / BDR(DH5), 2441 MHz

EUT: Helmet Mounted Wireless Headset; Type: NYSNO-10; Serial: 5002401

Mode: Bluetooth (fixed frequency, BDR, DH5) (UID: 0, Frame Length in ms: 0; PAR: 0; PMF: 1); **Frequency: 2441 MHz; Crest Factor: 1.0**

Medium: HSL2450(1711); Medium parameters used: $f = 2441$ MHz; $\sigma = 1.842$ S/m; $\epsilon_r = 37.89$; $\rho = 1000$ kg/m³

Measurement Standard: DASY5 (IEEE/IEC/ANSI C63.19-2007)

DASY Configuration: -Probe: EX3DV4 - SN3907; ConvF(7.37, 7.37, 7.37); Calibrated: 2017/02/27; -DASY52 52.8.8(1222); SEMCAD X 14.6.10(7331)
-Sensor-Surface: 2mm (Mechanical Surface Detection), z = 1.0, 31.0 -Electronics: DAE4 Sn554; Calibrated: 2017/05/18
-Phantom: SAM-Twin with CRP; Type: QD000P40CA; Serial: TP:1273; Phantom section: Left Section

helmet-mounted,sam-left/h2,2441,inner-ant-tilt2&d4mm,bdr(dh5)

Area:72x72,12 (7x7x1): Measurement grid: dx=12mm, dy=12mm; Maximum value of SAR (measured) = 0.722 W/kg

Area:72x72,12 (61x61x1): Interpolated grid: dx=1.200 mm, dy=1.200 mm; Maximum value of SAR (interpolated) = 0.788 W/kg

Zoom:30x30x30,5 (8x8x7)/Cube 0: Measurement grid: dx=5mm, dy=5mm, dz=5mm;

Reference Value = 19.15 V/m; Power Drift = -0.05 dB; Maximum value of SAR (measured) = 0.677 W/kg; Peak SAR (extrapolated) = 0.957 W/kg

SAR(1 g) = 0.495 W/kg; SAR(10 g) = 0.266 W/kg

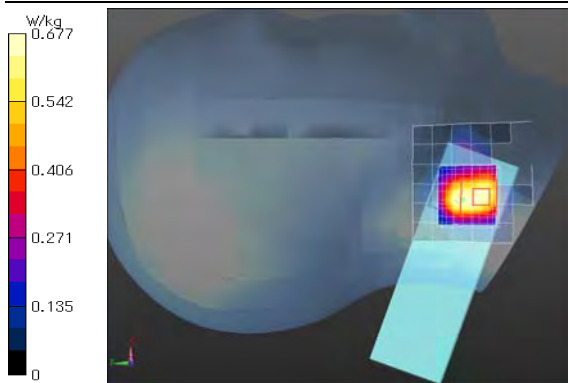

Remarks: * Date tested: 2017/11/10, Tested by: Hiroshi Naka; Tested place: No.7 shielded room,
* liquid depth: 153 mm (*LEFT ERP); Position: distance of EUT to phantom: 0 mm (2 mm to liquid); ambient: (24~25) deg.C. / (40~50) %RH,
* liquid temperature: 23.6(start)/23.7(end)/24.0(in check) deg.C.; * White cubic: zoom scan area, Red cubic: big=SAR(10g) / small=SAR(1g)

UL Japan, Inc.

Shonan EMC Lab.

1-22-3 Megumigaoka, Hiratsuka-shi, Kanagawa-ken, 259-1220 JAPAN
Telephone: +81 463 50 6400 / Facsimile: +81 463 50 6401

Appendix 2-2: SAR measurement data / Other SAR(1g) Plots (cont'd)

Plot 2-3: Back (With microphone) & gap=4mm / EDR(2DH5), 2402 MHz

EUT: Helmet Mounted Wireless Headset; Type: NYSNO-10; Serial: 5002401

Mode: Bluetooth (fixed frequency, EDR, 2DH5) (UID: 0, Frame Length in ms: 0; PAR: 0; PMF: 1); **Frequency: 2402 MHz; Crest Factor: 1.0**

Medium: HSL2450(1711); Medium parameters used: f = 2402 MHz; $\sigma = 1.793$ S/m; $\epsilon_r = 38.07$; $\rho = 1000$ kg/m³

Measurement Standard: DASY5 (IEEE/IEC/ANSI C63.19-2007)

DASY Configuration: -Probe: EX3DV4 - SN3907; ConvF(7.37, 7.37, 7.37); Calibrated: 2017/02/27; -DASY52 52.8.8(1222); SEMCAD X 14.6.10(7331)
-Sensor-Surface: 2mm (Mechanical Surface Detection), z = 1.0, 31.0, -Electronics: DAE4 Sn554; Calibrated: 2017/05/18
-Phantom: SAM-Twin with CRP; Type: QD000P40CA; Serial: TP:1273; Phantom section: Left Section

helmet-mounted,sam-left/h4,2402,inner-ant-tilt2&d4mm,edr(2dh5)

Area:72x72,12 (7x7x1): Measurement grid: dx=12mm, dy=12mm; Maximum value of SAR (measured) = 0.581 W/kg

Area:72x72,12 (61x61x1): Interpolated grid: dx=1.200 mm, dy=1.200 mm; Maximum value of SAR (interpolated) = 0.656 W/kg

Zoom:30x30x30,5 (7x8x7)/Cube 0: Measurement grid: dx=5mm, dy=5mm, dz=5mm;

Reference Value = 17.64 V/m; Power Drift = -0.05 dB; Maximum value of SAR (measured) = 0.550 W/kg; Peak SAR (extrapolated) = 0.790 W/kg

SAR(1 g) = 0.393 W/kg; SAR(10 g) = 0.217 W/kg

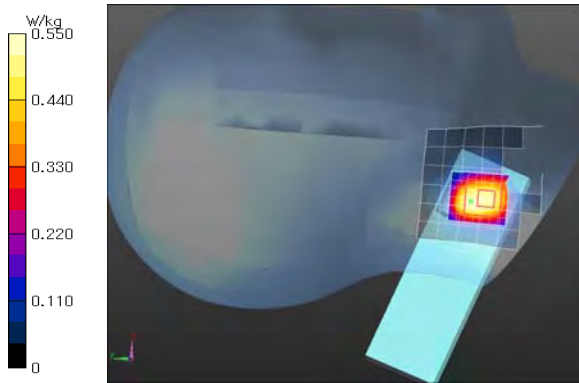

Remarks: * Date tested: 2017/11/10, Tested by: Hiroshi Naka; Tested place: No.7 shielded room,
* liquid depth: 153 mm (*LEFT ERP); Position: distance of EUT to phantom: 0 mm (2 mm to liquid); ambient: (24~25) deg.C. / (40~50) %RH,
* liquid temperature: 23.7(start)/23.8(end)/24.0(in check) deg.C.; * White cubic: zoom scan area, Red cubic: big=SAR(10g)/small=SAR(1g)

Plot 2-4: Back (With microphone) & gap=4mm / EDR(2DH5), 2480 MHz

EUT: Helmet Mounted Wireless Headset; Type: NYSNO-10; Serial: 5002401

Mode: Bluetooth (fixed frequency, EDR, 2DH5) (UID: 0, Frame Length in ms: 0; PAR: 0; PMF: 1); **Frequency: 2480 MHz; Crest Factor: 1.0**

Medium: HSL2450(1711); Medium parameters used: f = 2480 MHz; $\sigma = 1.879$ S/m; $\epsilon_r = 37.75$; $\rho = 1000$ kg/m³

Measurement Standard: DASY5 (IEEE/IEC/ANSI C63.19-2007)

DASY Configuration: -Probe: EX3DV4 - SN3907; ConvF(7.37, 7.37, 7.37); Calibrated: 2017/02/27; -DASY52 52.8.8(1222); SEMCAD X 14.6.10(7331)
-Sensor-Surface: 2mm (Mechanical Surface Detection), z = 1.0, 31.0, -Electronics: DAE4 Sn554; Calibrated: 2017/05/18
-Phantom: SAM-Twin with CRP; Type: QD000P40CA; Serial: TP:1273; Phantom section: Left Section

helmet-mounted,sam-left/h5,2480,inner-ant-tilt2&d4mm,edr(2dh5)

Area:72x72,12 (7x7x1): Measurement grid: dx=12mm, dy=12mm; Maximum value of SAR (measured) = 0.407 W/kg

Area:72x72,12 (61x61x1): Interpolated grid: dx=1.200 mm, dy=1.200 mm; Maximum value of SAR (interpolated) = 0.457 W/kg

Zoom:30x30x30,5 (7x8x7)/Cube 0: Measurement grid: dx=5mm, dy=5mm, dz=5mm;

Reference Value = 14.26 V/m; Power Drift = -0.06 dB; Maximum value of SAR (measured) = 0.443 W/kg; Peak SAR (extrapolated) = 0.563 W/kg

SAR(1 g) = 0.298 W/kg; SAR(10 g) = 0.156 W/kg

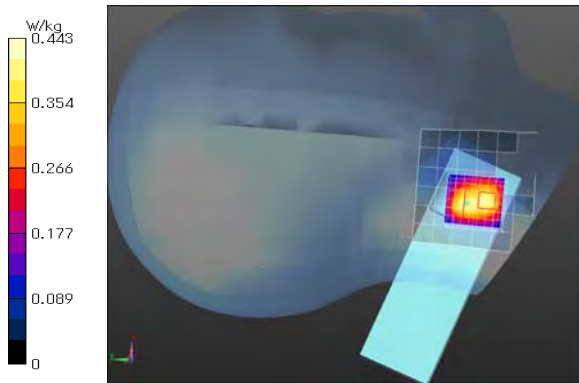

Remarks: * Date tested: 2017/11/10, Tested by: Hiroshi Naka; Tested place: No.7 shielded room,
* liquid depth: 153 mm (*LEFT ERP); Position: distance of EUT to phantom: 0 mm (2 mm to liquid); ambient: (24~25) deg.C. / (40~50) %RH,
* liquid temperature: 23.8(start)/23.8(end)/24.0(in check) deg.C.; * White cubic: zoom scan area, Red cubic: big=SAR(10g)/small=SAR(1g)

UL Japan, Inc.

Shonan EMC Lab.

1-22-3 Megumigaoka, Hiratsuka-shi, Kanagawa-ken, 259-1220 JAPAN
Telephone: +81 463 50 6400 / Facsimile: +81 463 50 6401

Appendix 2-2: SAR measurement data / Other SAR(1g) Plots (cont'd)

Plot 2-5: Front-tilt (With microphone) & touch (gap=0mm) / EDR(3DH5), 2441 MHz

EUT: Helmet Mounted Wireless Headset; Type: NYSNO-10; Serial: 5002401

Mode: Bluetooth (fixed frequency, EDR, 3DH5) (UID: 0, Frame Length in ms: 0; PAR: 0; PMF: 1); **Frequency: 2441 MHz; Crest Factor: 1.0**

Medium: HSL2450(1711); Medium parameters used: $f = 2441$ MHz; $\sigma = 1.842$ S/m; $\epsilon_r = 37.89$; $\rho = 1000$ kg/m³

Measurement Standard: DASY5 (IEEE/IEC/ANSI C63.19-2007)

DASY Configuration: -Probe: EX3DV4 - SN3907; ConvF(7.37, 7.37, 7.37); Calibrated: 2017/02/27; -DASY52 52.8.8(1222); SEMCAD X 14.6.10(7331)
-Sensor-Surface: 2mm (Mechanical Surface Detection), z = 1.0, 31.0 -Electronics: DAE4 Sn554; Calibrated: 2017/05/18
-Phantom: SAM-Twin with CRP; Type: QD000P40CA; Serial: TP:1273; Phantom section: Left Section

helmet-mounted/h6,2441,outer-ant-tilt&touch,edr(3dh5)/

Area:72x72,12 (7x7x1): Measurement grid: dx=12mm, dy=12mm; Maximum value of SAR (measured) = 0.708 W/kg

Area:72x72,12 (61x61x1): Interpolated grid: dx=1.200 mm, dy=1.200 mm; Maximum value of SAR (interpolated) = 0.944 W/kg

Zoom:30x30x30,5 (7x7x7)/Cube 0: Measurement grid: dx=5mm, dy=5mm, dz=5mm;

Reference Value = 20.22 V/m; Power Drift = -0.01 dB; Maximum value of SAR (measured) = 0.792 W/kg; Peak SAR (extrapolated) = 1.14 W/kg

SAR(1 g) = 0.522 W/kg; SAR(10 g) = 0.269 W/kg

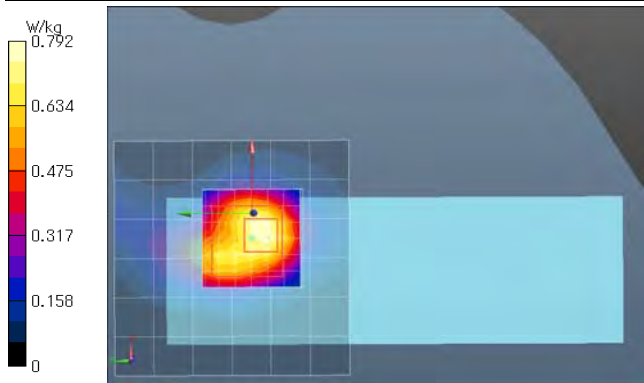

Remarks: * Date tested: 2017/11/10, Tested by: Hiroshi Naka; Tested place: No.7 shielded room,
* liquid depth: 183 mm (*Flat); Position: distance of EUT to phantom: 0 mm (2 mm to liquid); ambient: (24~25) deg.C. / (40~50) %RH,
* liquid temperature: 23.9(start)/23.9(end)/24.0(in check) deg.C.; * White cubic: zoom scan area, Red cubic: big=SAR(10g)/small=SAR(1g)

Plot 2-6: Front-tilt (With microphone) & touch (gap=0mm) / BDR(DH5), 2441 MHz

EUT: Helmet Mounted Wireless Headset; Type: NYSNO-10; Serial: 5002401

Mode: Bluetooth (fixed frequency, BDR, DH5) (UID: 0, Frame Length in ms: 0; PAR: 0; PMF: 1); **Frequency: 2441 MHz; Crest Factor: 1.0**

Medium: HSL2450(1711); Medium parameters used: $f = 2441$ MHz; $\sigma = 1.842$ S/m; $\epsilon_r = 37.89$; $\rho = 1000$ kg/m³

Measurement Standard: DASY5 (IEEE/IEC/ANSI C63.19-2007)

DASY Configuration: -Probe: EX3DV4 - SN3907; ConvF(7.37, 7.37, 7.37); Calibrated: 2017/02/27; -Electronics: DAE4 Sn554; Calibrated: 2017/05/18
-Sensor-Surface: 2mm (Mechanical Surface Detection (Locations From Previous Scan Used)), Sensor-Surface: 2mm (Mechanical Surface Detection), z = 1.0, 31.0
-Phantom: SAM-Twin with CRP; Type: QD000P40CA; Serial: TP:1273; Phantom section: Flat Section -DASY52 52.8.8(1222); SEMCAD X 14.6.10(7331)

helmet-mounted/h7,2441,outer-ant-tilt&touch,bdr(dh5)/

Area:72x72,12 (7x7x1): Measurement grid: dx=12mm, dy=12mm; Maximum value of SAR (measured) = 0.700 W/kg

Area:72x72,12 (61x61x1): Interpolated grid: dx=1.200 mm, dy=1.200 mm; Maximum value of SAR (interpolated) = 0.916 W/kg

Zoom:30x30x30,5 (7x7x7)/Cube 0: Measurement grid: dx=5mm, dy=5mm, dz=5mm;

Reference Value = 20.00 V/m; Power Drift = -0.05 dB; Maximum value of SAR (measured) = 0.772 W/kg; Peak SAR (extrapolated) = 1.11 W/kg

SAR(1 g) = 0.509 W/kg; SAR(10 g) = 0.262 W/kg

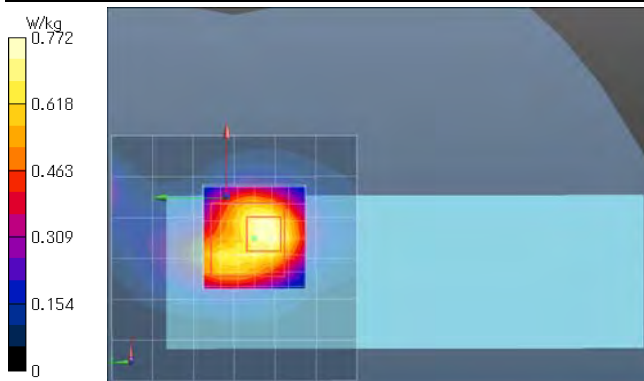

Remarks: * Date tested: 2017/11/10, Tested by: Hiroshi Naka; Tested place: No.7 shielded room,
* liquid depth: 183 mm (*Flat); Position: distance of EUT to phantom: 0 mm (2 mm to liquid); ambient: (24~25) deg.C. / (40~50) %RH,
* liquid temperature: 23.9(start)/24.0(end)/24.0(in check) deg.C.; * White cubic: zoom scan area, Red cubic: big=SAR(10g)/small=SAR(1g)

UL Japan, Inc.

Shonan EMC Lab.

1-22-3 Megumigaoka, Hiratsuka-shi, Kanagawa-ken, 259-1220 JAPAN
Telephone: +81 463 50 6400 / Facsimile: +81 463 50 6401

Appendix 2-2: SAR measurement data / Other SAR(1g) Plots (cont'd)

Plot 2-7: Front-tilt (With microphone) & touch (gap=0mm) / EDR(2DH5), 2441 MHz

EUT: Helmet Mounted Wireless Headset; Type: NYSNO-10; Serial: 5002401

Mode: Bluetooth (fixed frequency, EDR, 2DH5) (UID: 0, Frame Length in ms: 0; PAR: 0; PMF: 1); **Frequency: 2441 MHz; Crest Factor: 1.0**

Medium: HSL2450(1711); Medium parameters used: $f = 2441$ MHz; $\sigma = 1.842$ S/m; $\epsilon_r = 37.89$; $\rho = 1000$ kg/m³

Measurement Standard: DASY5 (IEEE/IEC/ANSI C63.19-2007)

DASY Configuration: -Probe: EX3DV4 - SN3907; ConvF(7.37, 7.37, 7.37); Calibrated: 2017/02/27; -Electronics: DAE4 Sn554; Calibrated: 2017/05/18
-Sensor-Surface: 2mm (Mechanical Surface Detection (Locations From Previous Scan Used)), Sensor-Surface: 2mm (Mechanical Surface Detection), z = 1.0, 31.0, 186.0
-Phantom: SAM-Twin with CRP; Type: QD000P40CA; Serial: TP:1273; Phantom section: Flat Section -DASY52 52.8.8(1222); SEMCAD X 14.6.10(7331)

helmet-mounted/h8,2441,outer-ant-tilt&touch,edr(2dh5)/

Area:72x72,12 (7x7x1): Measurement grid: dx=12mm, dy=12mm; Maximum value of SAR (measured) = 0.704 W/kg

Area:72x72,12 (61x61x1): Interpolated grid: dx=1.200 mm, dy=1.200 mm; Maximum value of SAR (interpolated) = 0.945 W/kg

Z:185,5 (1x1x38): Measurement grid: dx=20mm, dy=20mm, dz=5mm; Maximum value of SAR (measured) = 0.798 W/kg

Zoom:30x30x30,5 (7x7x7)/Cube 0: Measurement grid: dx=5mm, dy=5mm, dz=5mm;

Reference Value = 20.39 V/m; Power Drift = -0.05 dB; Maximum value of SAR (measured) = 0.791 W/kg; Peak SAR (extrapolated) = 1.14 W/kg

SAR(1g) = 0.521 W/kg; SAR(10g) = 0.268 W/kg

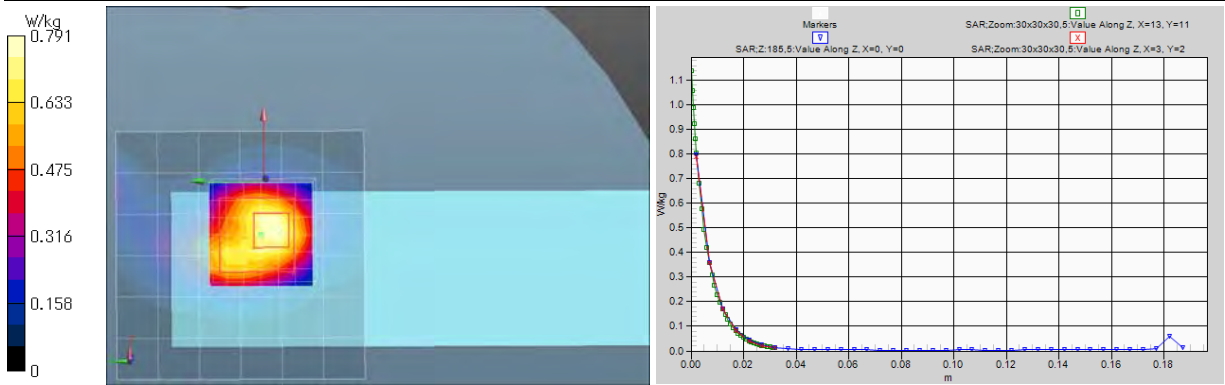

Remarks: * .Date tested: 2017/11/10, Tested by: Hiroshi Naka; Tested place:No.7 shielded room,
* .liquid depth: 183 mm (*.Flat); Position: distance of EUT to phantom: 0 mm (2 mm to liquid); ambient: (24~25) deg.C. / (40~50) %RH,
* .liquid temperature: 23.9(start)/24.0(end)/24.0(in check) deg.C.; *.White cubic: zoom scan area, Red cubic: big=SAR(10g)/small=SAR(1g)

Plot 2-8: Front-tilt (With microphone) & touch (gap=0mm) / EDR(2DH5), 2402 MHz

EUT: Helmet Mounted Wireless Headset; Type: NYSNO-10; Serial: 5002401

Mode: Bluetooth (fixed frequency, EDR, 2DH5) (UID: 0, Frame Length in ms: 0; PAR: 0; PMF: 1); **Frequency: 2402 MHz; Crest Factor: 1.0**

Medium: HSL2450(1711); Medium parameters used: $f = 2402$ MHz; $\sigma = 1.793$ S/m; $\epsilon_r = 38.07$; $\rho = 1000$ kg/m³

Measurement Standard: DASY5 (IEEE/IEC/ANSI C63.19-2007)

DASY Configuration: -Probe: EX3DV4 - SN3907; ConvF(7.37, 7.37, 7.37); Calibrated: 2017/02/27; -Electronics: DAE4 Sn554; Calibrated: 2017/05/18
-Sensor-Surface: 2mm (Mechanical Surface Detection (Locations From Previous Scan Used)), Sensor-Surface: 2mm (Mechanical Surface Detection), z = 1.0, 31.0
-Phantom: SAM-Twin with CRP; Type: QD000P40CA; Serial: TP:1273; Phantom section: Flat Section -DASY52 52.8.8(1222); SEMCAD X 14.6.10(7331)

helmet-mounted/h9,2402,outer-ant-tilt&touch,edr(2dh5)/

Area:72x72,12 (7x7x1): Measurement grid: dx=12mm, dy=12mm; Maximum value of SAR (measured) = 0.576 W/kg

Area:72x72,12 (61x61x1): Interpolated grid: dx=1.200 mm, dy=1.200 mm; Maximum value of SAR (interpolated) = 0.762 W/kg

Zoom:30x30x30,5 (7x7x7)/Cube 0: Measurement grid: dx=5mm, dy=5mm, dz=5mm;

Reference Value = 18.40 V/m; Power Drift = -0.06 dB; Maximum value of SAR (measured) = 0.638 W/kg; Peak SAR (extrapolated) = 0.913 W/kg

SAR(1g) = 0.420 W/kg; SAR(10g) = 0.214 W/kg

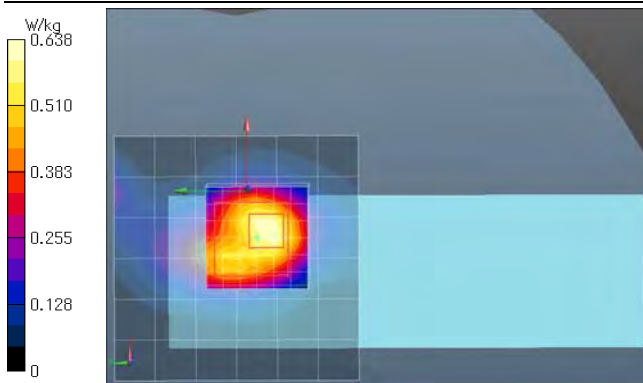

Remarks: * .Date tested: 2017/11/10, Tested by: Hiroshi Naka; Tested place:No.7 shielded room,
* .liquid depth: 183 mm (*.Flat); Position: distance of EUT to phantom: 0 mm (2 mm to liquid); ambient: (24~25) deg.C. / (40~50) %RH,
* .liquid temperature: 24.0(start)/24.0(end)/24.0(in check) deg.C.; *.White cubic: zoom scan area, Red cubic: big=SAR(10g)/small=SAR(1g)

UL Japan, Inc.

Shonan EMC Lab.

1-22-3 Megumigaoka, Hiratsuka-shi, Kanagawa-ken, 259-1220 JAPAN
Telephone: +81 463 50 6400 / Facsimile: +81 463 50 6401

Appendix 2-2: SAR measurement data / Other SAR(1g) Plots (cont'd)

Plot 2-9: Front-tilt (With microphone) & touch (gap=0mm) / EDR(2DH5), 2480 MHz

EUT: Helmet Mounted Wireless Headset; Type: NYSNO-10; Serial: 5002401

Mode: Bluetooth (fixed frequency, EDR, 2DH5) (UID: 0, Frame Length in ms: 0; PAR: 0; PMF: 1); **Frequency: 2480 MHz; Crest Factor: 1.0**

Medium: HSL2450(1711); Medium parameters used: f = 2480 MHz; $\sigma = 1.879$ S/m; $\epsilon_r = 37.75$; $\rho = 1000$ kg/m³

Measurement Standard: DASY5 (IEEE/IEC/ANSI C63.19-2007)

DASY Configuration: -Probe: EX3DV4 - SN3907; ConvF(7.37, 7.37, 7.37); Calibrated: 2017/02/27; -Electronics: DAE4 Sn554; Calibrated: 2017/05/18
-Sensor-Surface: 2mm (Mechanical Surface Detection (Locations From Previous Scan Used)), Sensor-Surface: 2mm (Mechanical Surface Detection), z = 1.0, 31.0,
-Phantom: SAM-Twin with CRP; Type: QD000P40CA; Serial: TP:1273; Phantom section: Flat Section -DASY52 52.8.8(1222); SEMCAD X 14.6.10(7331)

helmet-mounted/h10,2480,outer-ant-tilt&touch,edr(2dh5)/

Area:72x72,12 (7x7x1): Measurement grid: dx=12mm, dy=12mm; Maximum value of SAR (measured) = 0.440 W/kg

Area:72x72,12 (61x61x1): Interpolated grid: dx=1.200 mm, dy=1.200 mm; Maximum value of SAR (interpolated) = 0.553 W/kg

Zoom:30x30x30,5 (7x7x7)/Cube 0: Measurement grid: dx=5mm, dy=5mm, dz=5mm;

Reference Value = 15.38 V/m; Power Drift = -0.08 dB; Maximum value of SAR (measured) = 0.456 W/kg; Peak SAR (extrapolated) = 0.655 W/kg

SAR(1 g) = 0.300 W/kg; SAR(10 g) = 0.158 W/kg

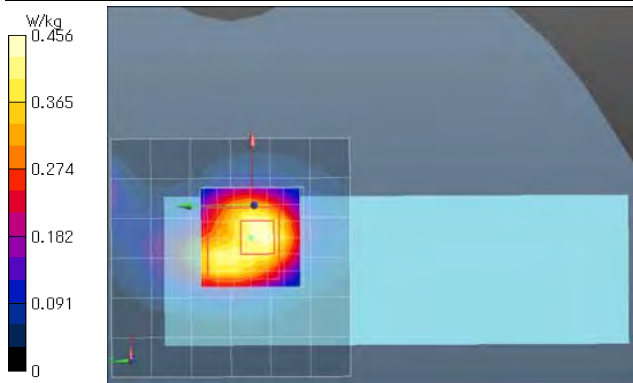

Remarks: * Date tested: 2017/11/10, Tested by: Hiroshi Naka; Tested place: No.7 shielded room,
* liquid depth: 183 mm (*Flat); Position: distance of EUT to phantom: 0 mm (2 mm to liquid); ambient: (24~25) deg.C. / (40~50) %RH,
* liquid temperature: 24.0(start)/24.0(end)/24.0(in check) deg.C.; *White cubic: zoom scan area, Red cubic: big=SAR(10g)/small=SAR(1g)

Plot 2-10: Top (With microphone) & touch (gap=0mm) / EDR(2DH5), 2441 MHz

EUT: Helmet Mounted Wireless Headset; Type: NYSNO-10; Serial: 5002401

Mode: Bluetooth (fixed frequency, EDR, 3DH5) (UID: 0, Frame Length in ms: 0; PAR: 0; PMF: 1); **Frequency: 2441 MHz; Crest Factor: 1.0**

Medium: HSL2450(1711); Medium parameters used: f = 2441 MHz; $\sigma = 1.842$ S/m; $\epsilon_r = 37.89$; $\rho = 1000$ kg/m³

Measurement Standard: DASY5 (IEEE/IEC/ANSI C63.19-2007)

DASY Configuration: -Probe: EX3DV4 - SN3907; ConvF(7.37, 7.37, 7.37); Calibrated: 2017/02/27; -DASY52 52.8.8(1222); SEMCAD X 14.6.10(7331)
-Sensor-Surface: 2mm (Mechanical Surface Detection), z = 1.0, 31.0 -Electronics: DAE4 Sn554; Calibrated: 2017/05/18
-Phantom: SAM-Twin with CRP; Type: QD000P40CA; Serial: TP:1273; Phantom section: Left Section

helmet-mounted/h12,2441,top(ant)&touch,edr(2dh5)/

Area:72x84,12 (7x8x1): Measurement grid: dx=12mm, dy=12mm; Maximum value of SAR (measured) = 0.202 W/kg

Area:72x84,12 (61x71x1): Interpolated grid: dx=1.200 mm, dy=1.200 mm; Maximum value of SAR (interpolated) = 0.209 W/kg

Zoom:30x30x30,5 (7x8x7)/Cube 0: Measurement grid: dx=5mm, dy=5mm, dz=5mm;

Reference Value = 11.37 V/m; Power Drift = -0.02 dB; Maximum value of SAR (measured) = 0.242 W/kg; Peak SAR (extrapolated) = 0.387 W/kg

SAR(1 g) = 0.134 W/kg; SAR(10 g) = 0.066 W/kg

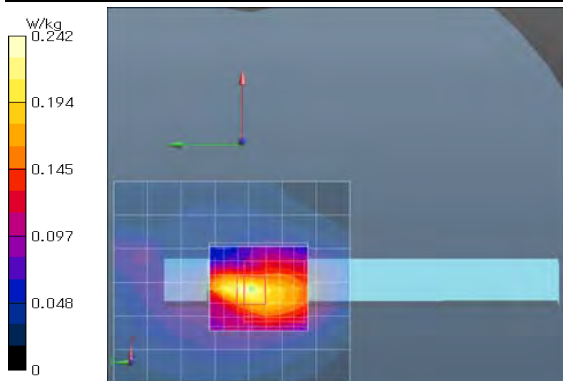

Remarks: * Date tested: 2017/11/10, Tested by: Hiroshi Naka; Tested place: No.7 shielded room,
* liquid depth: 183 mm (*Flat); Position: distance of EUT to phantom: 0 mm (2 mm to liquid); ambient: (24~25) deg.C. / (40~50) %RH,
* liquid temperature: 24.1(start)/24.1(end)/24.0(in check) deg.C.; *White cubic: zoom scan area, Red cubic: big=SAR(10g)/small=SAR(1g)

UL Japan, Inc.

Shonan EMC Lab.

1-22-3 Megumigaoka, Hiratsuka-shi, Kanagawa-ken, 259-1220 JAPAN
Telephone: +81 463 50 6400 / Facsimile: +81 463 50 6401

Appendix 2-2: SAR measurement data / Other SAR(1g) Plots (cont'd)

Plot 3-1: Back (No microphone) & gap=4mm / EDR(3DH5), 2441 MHz

EUT: Helmet Mounted Wireless Headset; Type: NYSNO-10; Serial: 5002401

Mode: Bluetooth (fixed frequency, EDR, 3DH5) (UID: 0, Frame Length in ms: 0; PAR: 0; PMF: 1); **Frequency: 2441 MHz; Crest Factor: 1.0**

Medium: HSL2450(1711); Medium parameters used: f = 2441 MHz; $\sigma = 1.847$ S/m; $\epsilon_r = 37.60$; $\rho = 1000$ kg/m³

Measurement Standard: DASY5 (IEEE/IEC/ANSI C63.19-2007)

DASY Configuration: -Probe: EX3DV4 - SN3907; ConvF(7.37, 7.37, 7.37); Calibrated: 2017/02/27; -DASY52 52.8.8(1222); SEMCAD X 14.6.10(7331)
-Sensor-Surface: 2mm (Mechanical Surface Detection), z = 1.0, 31.0 -Electronics: DAE4 Sn554; Calibrated: 2017/05/18
-Phantom: SAM-Twin with CRP; Type: QD000P40CA; Serial: TP:1273; Phantom section: Left Section

helmet-mounted,sam-left,no.mic/h15,2441,inner-ant-tilt2&d4mm,edr(3dh5)/

Area:72x72,12 (7x7x1): Measurement grid: dx=12mm, dy=12mm; Maximum value of SAR (measured) = 0.958 W/kg

Area:72x72,12 (61x61x1): Interpolated grid: dx=1.200 mm, dy=1.200 mm; Maximum value of SAR (interpolated) = 1.03 W/kg

Zoom:30x30x30,5 (7x7x7)/Cube 0: Measurement grid: dx=5mm, dy=5mm, dz=5mm;

Reference Value = 22.82 V/m; Power Drift = 0.08 dB; Maximum value of SAR (measured) = 0.929 W/kg; Peak SAR (extrapolated) = 1.26 W/kg

SAR(1 g) = 0.639 W/kg; SAR(10 g) = 0.323 W/kg

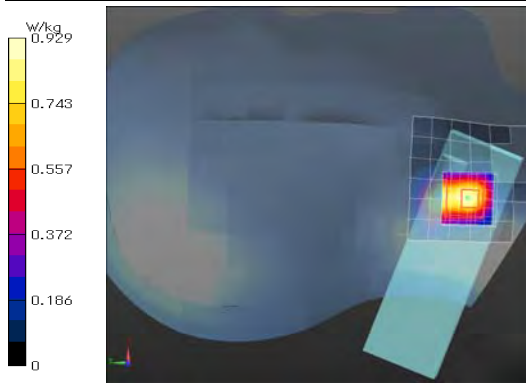

Remarks: * Date tested: 2017/11/14, Tested by: Hiroshi Naka; Tested place: No.7 shielded room,
* liquid depth: 150 mm (*LEFT ERP); Position: distance of EUT to phantom: 0 mm (2 mm to liquid); ambient: (24~25) deg.C. / (40~50) %RH,
* liquid temperature: 23.7(start)/23.7(end)/24.0(in check) deg.C.; * White cubic: zoom scan area, Red cubic: big=SAR(10g)/small=SAR(1g)

Plot 3-2: Back (No microphone) & gap=4mm / BDR(DH5), 2441 MHz

EUT: Helmet Mounted Wireless Headset; Type: NYSNO-10; Serial: 5002401

Mode: Bluetooth (fixed frequency, BDR, DH5) (UID: 0, Frame Length in ms: 0; PAR: 0; PMF: 1); **Frequency: 2441 MHz; Crest Factor: 1.0**

Medium: HSL2450(1711); Medium parameters used: f = 2441 MHz; $\sigma = 1.847$ S/m; $\epsilon_r = 37.60$; $\rho = 1000$ kg/m³

Measurement Standard: DASY5 (IEEE/IEC/ANSI C63.19-2007)

DASY Configuration: -Probe: EX3DV4 - SN3907; ConvF(7.37, 7.37, 7.37); Calibrated: 2017/02/27; -DASY52 52.8.8(1222); SEMCAD X 14.6.10(7331)
-Sensor-Surface: 2mm (Mechanical Surface Detection), z = 1.0, 31.0 -Electronics: DAE4 Sn554; Calibrated: 2017/05/18
-Phantom: SAM-Twin with CRP; Type: QD000P40CA; Serial: TP:1273; Phantom section: Left Section

helmet-mounted,sam-left,no.mic/h16,2441,inner-ant-tilt2&d4mm,bdr(dh5)/

Area:72x72,12 (7x7x1): Measurement grid: dx=12mm, dy=12mm; Maximum value of SAR (measured) = 0.907 W/kg

Area:72x72,12 (61x61x1): Interpolated grid: dx=1.200 mm, dy=1.200 mm; Maximum value of SAR (interpolated) = 0.986 W/kg

Zoom:30x30x30,5 (7x7x7)/Cube 0: Measurement grid: dx=5mm, dy=5mm, dz=5mm;

Reference Value = 21.51 V/m; Power Drift = -0.02 dB; Maximum value of SAR (measured) = 0.889 W/kg; Peak SAR (extrapolated) = 1.24 W/kg

SAR(1 g) = 0.596 W/kg; SAR(10 g) = 0.309 W/kg

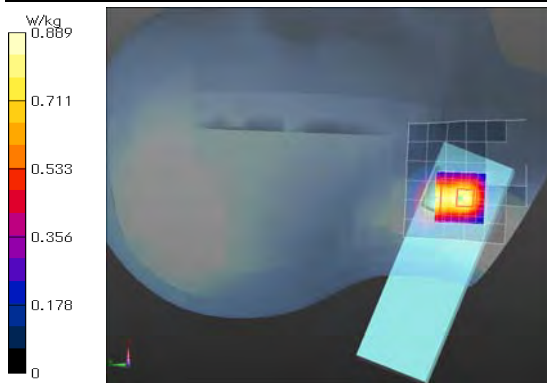

Remarks: * Date tested: 2017/11/14, Tested by: Hiroshi Naka; Tested place: No.7 shielded room,
* liquid depth: 150 mm (*LEFT ERP); Position: distance of EUT to phantom: 0 mm (2 mm to liquid); ambient: (24~25) deg.C. / (40~50) %RH,
* liquid temperature: 23.7(start)/23.7(end)/24.0(in check) deg.C.; * White cubic: zoom scan area, Red cubic: big=SAR(10g)/small=SAR(1g)

UL Japan, Inc.

Shonan EMC Lab.

1-22-3 Megumigaoka, Hiratsuka-shi, Kanagawa-ken, 259-1220 JAPAN
Telephone: +81 463 50 6400 / Facsimile: +81 463 50 6401

Appendix 2-2: SAR measurement data / Other SAR(1g) Plots (cont'd)

Plot 3-3: Back (No microphone) & gap=4mm / EDR(2DH5), 2441 MHz

EUT: Helmet Mounted Wireless Headset; Type: NYSNO-10; Serial: 5002401

Mode: Bluetooth (fixed frequency, EDR, 2DH5) (UID: 0, Frame Length in ms: 0; PAR: 0; PMF: 1); **Frequency: 2441 MHz; Crest Factor: 1.0**

Medium: HSL2450(1711); Medium parameters used: $f = 2441$ MHz; $\sigma = 1.847$ S/m; $\epsilon_r = 37.60$; $\rho = 1000$ kg/m³

Measurement Standard: DASY5 (IEEE/IEC/ANSI C63.19-2007)

DASY Configuration: -Probe: EX3DV4 - SN3907; ConvF(7.37, 7.37, 7.37); Calibrated: 2017/02/27; -DASY52 52.8.8(1222); SEMCAD X 14.6.10(7331)
-Sensor-Surface: 2mm (Mechanical Surface Detection), z = 1.0, 31.0, 161.0 -Electronics: DAE4 Sn554; Calibrated: 2017/05/18
-Phantom: SAM-Twin with CRP; Type: QD000P40CA; Serial: TP:1273; Phantom section: Left Section

helmet-mounted,sam-left,no.mic/h14,2441,inner-ant-tilt2&d4mm,edr(2dh5)/

Area:72x72,12 (7x7x1): Measurement grid: dx=12mm, dy=12mm; Maximum value of SAR (measured) = 1.02 W/kg

Area:72x72,12 (61x61x1): Interpolated grid: dx=1.200 mm, dy=1.200 mm; Maximum value of SAR (interpolated) = 1.10 W/kg

Z:160,5 (1x1x33): Measurement grid: dx=20mm, dy=20mm, dz=5mm; Maximum value of SAR (measured) = 0.959 W/kg

Zoom:30x30x30,5 (7x8x7)/Cube 0: Measurement grid: dx=5mm, dy=5mm, dz=5mm;

Reference Value = 23.55 V/m; Power Drift = 0.04 dB; Maximum value of SAR (measured) = 0.964 W/kg; Peak SAR (extrapolated) = 1.35 W/kg

SAR(1g) = 0.679 W/kg; SAR(10g) = 0.343 W/kg

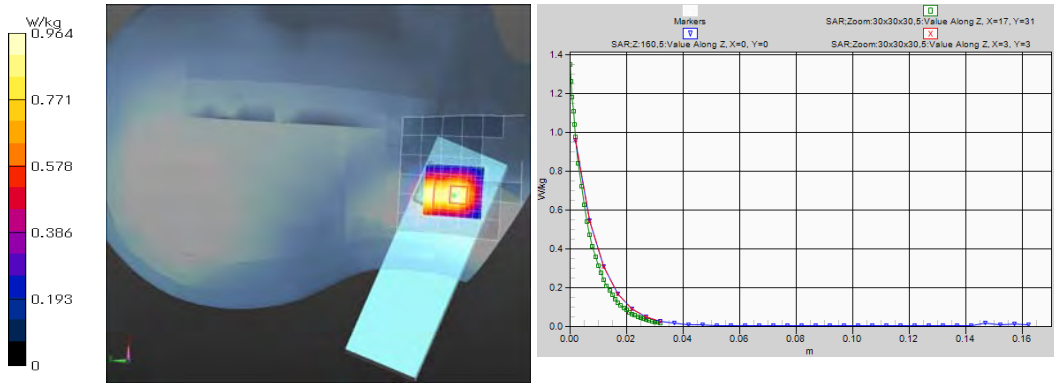

Remarks: * .Date tested: 2017/11/14, Tested by: Hiroshi Naka; Tested place:No.7 shielded room,
* .liquid depth: 150 mm (*.LEFT ERP); Position: distance of EUT to phantom: 0 mm (2 mm to liquid); ambient: (24~25) deg.C. / (40~50) %RH,
* .liquid temperature: 23.8(start)/23.7(end)/24.0(in check) deg.C.; *.White cubic: zoom scan area, Red cubic: big=SAR(10g)/small=SAR(1g)

Plot 3-4: Back (No microphone) & gap=4mm / EDR(2DH5), 2402 MHz

EUT: Helmet Mounted Wireless Headset; Type: NYSNO-10; Serial: 5002401

Mode: Bluetooth (fixed frequency, EDR, 2DH5) (UID: 0, Frame Length in ms: 0; PAR: 0; PMF: 1); **Frequency: 2402 MHz; Crest Factor: 1.0**

Medium: HSL2450(1711); Medium parameters used: $f = 2402$ MHz; $\sigma = 1.795$ S/m; $\epsilon_r = 37.77$; $\rho = 1000$ kg/m³

Measurement Standard: DASY5 (IEEE/IEC/ANSI C63.19-2007)

DASY Configuration: -Probe: EX3DV4 - SN3907; ConvF(7.37, 7.37, 7.37); Calibrated: 2017/02/27; -DASY52 52.8.8(1222); SEMCAD X 14.6.10(7331)
-Sensor-Surface: 2mm (Mechanical Surface Detection), z = 1.0, 31.0 -Electronics: DAE4 Sn554; Calibrated: 2017/05/18
-Phantom: SAM-Twin with CRP; Type: QD000P40CA; Serial: TP:1273; Phantom section: Left Section

helmet-mounted,sam-left,no.mic/h17,2402,inner-ant-tilt2&d4mm,edr(2dh5)/

Area:72x72,12 (7x7x1): Measurement grid: dx=12mm, dy=12mm; Maximum value of SAR (measured) = 0.727 W/kg

Area:72x72,12 (61x61x1): Interpolated grid: dx=1.200 mm, dy=1.200 mm; Maximum value of SAR (interpolated) = 0.794 W/kg

Zoom:30x30x30,5 (7x8x7)/Cube 0: Measurement grid: dx=5mm, dy=5mm, dz=5mm;

Reference Value = 20.11 V/m; Power Drift = 0.02 dB; Maximum value of SAR (measured) = 0.710 W/kg; Peak SAR (extrapolated) = 1.00 W/kg

SAR(1g) = 0.490 W/kg; SAR(10g) = 0.255 W/kg

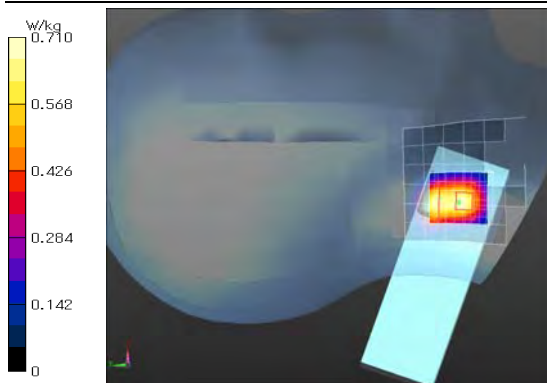

Remarks: * .Date tested: 2017/11/14, Tested by: Hiroshi Naka; Tested place:No.7 shielded room,
* .liquid depth: 150 mm (*.LEFT ERP); Position: distance of EUT to phantom: 0 mm (2 mm to liquid); ambient: (24~25) deg.C. / (40~50) %RH,
* .liquid temperature: 23.7(start)/23.8(end)/24.0(in check) deg.C.; *.White cubic: zoom scan area, Red cubic: big=SAR(10g)/small=SAR(1g)

UL Japan, Inc.

Shonan EMC Lab.

1-22-3 Megumigaoka, Hiratsuka-shi, Kanagawa-ken, 259-1220 JAPAN
Telephone: +81 463 50 6400 / Facsimile: +81 463 50 6401

Appendix 2-2: SAR measurement data / Other SAR(1g) Plots (cont'd)

Plot 3-5: Back (No microphone) & gap=4mm / EDR(2DH5), 2480 MHz

EUT: Helmet Mounted Wireless Headset; Type: NYSNO-10; Serial: 5002401

Mode: Bluetooth (fixed frequency, EDR, 2DH5) (UID: 0, Frame Length in ms: 0; PAR: 0; PMF: 1); **Frequency: 2480 MHz; Crest Factor: 1.0**

Medium: HSL2450(1711); Medium parameters used: f = 2480 MHz; $\sigma = 1.894$ S/m; $\epsilon_r = 37.42$; $\rho = 1000$ kg/m³

Measurement Standard: DASY5 (IEEE/IEC/ANSI C63.19-2007)

DASY Configuration: -Probe: EX3DV4 - SN3907; ConvF(7.37, 7.37, 7.37); Calibrated: 2017/02/27; -DASY52 52.8.8(1222); SEMCAD X 14.6.10(7331)
-Sensor-Surface: 2mm (Mechanical Surface Detection), z = 1.0, 31.0 -Electronics: DAE4 Sn554; Calibrated: 2017/05/18
-Phantom: SAM-Twin with CRP; Type: QD000P40CA; Serial: TP:1273; Phantom section: Left Section

helmet-mounted,sam-left,no.mic/h18,2480,inner-ant-tilt2&d4mm,edr(2dh5)/

Area:72x72,12 (7x7x1): Measurement grid: dx=12mm, dy=12mm; Maximum value of SAR (measured) = 0.569 W/kg

Area:72x72,12 (61x61x1): Interpolated grid: dx=1.200 mm, dy=1.200 mm; Maximum value of SAR (interpolated) = 0.610 W/kg

Zoom:30x30x30,5 (7x8x7)/Cube 0: Measurement grid: dx=5mm, dy=5mm, dz=5mm;

Reference Value = 17.08 V/m; Power Drift = 0.03 dB; Maximum value of SAR (measured) = 0.538 W/kg; Peak SAR (extrapolated) = 0.768 W/kg

SAR(1 g) = 0.374 W/kg; SAR(10 g) = 0.188 W/kg

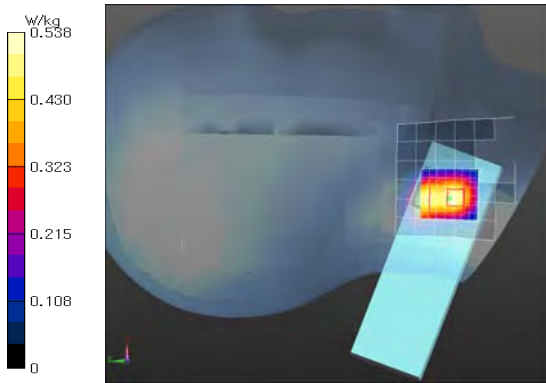

Remarks: * Date tested: 2017/11/14, Tested by: Hiroshi Naka; Tested place:No.7 shielded room,
* liquid depth: 150 mm (*LEFT ERP); Position: distance of EUT to phantom: 0 mm (2 mm to liquid); ambient: (24~25) deg.C. / (40~50) %RH,
* liquid temperature: 23.8(start)/23.9(end)/24.0(in check) deg.C.; * White cubic: zoom scan area, Red cubic: big=SAR(10g)/small=SAR(1g)

Plot 3-6: Front-tilt (No microphone) & touch (gap=0mm) / EDR(3DH5), 2441 MHz

EUT: Helmet Mounted Wireless Headset; Type: NYSNO-10; Serial: 5002401

Mode: Bluetooth (fixed frequency, EDR, 3DH5) (UID: 0, Frame Length in ms: 0; PAR: 0; PMF: 1); **Frequency: 2441 MHz; Crest Factor: 1.0**

Medium: HSL2450(1711); Medium parameters used: f = 2441 MHz; $\sigma = 1.847$ S/m; $\epsilon_r = 37.60$; $\rho = 1000$ kg/m³

Measurement Standard: DASY5 (IEEE/IEC/ANSI C63.19-2007)

DASY Configuration: -Probe: EX3DV4 - SN3907; ConvF(7.37, 7.37, 7.37); Calibrated: 2017/02/27; -Electronics: DAE4 Sn554; Calibrated: 2017/05/18
-Sensor-Surface: 2mm (Mechanical Surface Detection (Locations From Previous Scan Used)), Sensor-Surface: 2mm (Mechanical Surface Detection), z = 1.0, 31.0
-Phantom: SAM-Twin with CRP; Type: QD000P40CA; Serial: TP:1273; Phantom section: Flat Section -DASY52 52.8.8(1222); SEMCAD X 14.6.10(7331)

helmet-mounted,no.mic/h20,2441,outer-ant-tilt&touch,edr(3dh5)/

Area:72x72,12 (7x7x1): Measurement grid: dx=12mm, dy=12mm; Maximum value of SAR (measured) = 0.950 W/kg

Area:72x72,12 (61x61x1): Interpolated grid: dx=1.200 mm, dy=1.200 mm; Maximum value of SAR (interpolated) = 1.20 W/kg

Zoom:30x30x30,5 (7x7x7)/Cube 0: Measurement grid: dx=5mm, dy=5mm, dz=5mm;

Reference Value = 23.14 V/m; Power Drift = -0.03 dB; Maximum value of SAR (measured) = 1.07 W/kg; Peak SAR (extrapolated) = 1.45 W/kg

SAR(1 g) = 0.733 W/kg; SAR(10 g) = 0.368 W/kg

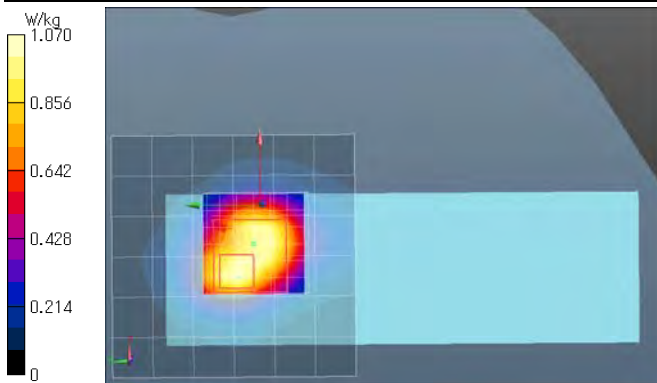

Remarks: * Date tested: 2017/11/14, Tested by: Hiroshi Naka; Tested place:No.7 shielded room,
* liquid depth: 183 mm (*Flat); Position: distance of EUT to phantom: 0 mm (2 mm to liquid); ambient: (24~25) deg.C. / (40~50) %RH,
* liquid temperature: 24.0(start)/24.0(end)/24.0(in check) deg.C.; * White cubic: zoom scan area, Red cubic: big=SAR(10g)/small=SAR(1g)

UL Japan, Inc.

Shonan EMC Lab.

1-22-3 Megumigaoka, Hiratsuka-shi, Kanagawa-ken, 259-1220 JAPAN
Telephone: +81 463 50 6400 / Facsimile: +81 463 50 6401

Appendix 2-2: SAR measurement data / Other SAR(1g) Plots (cont'd)

Plot 3-7: Front-tilt (No microphone) & touch (gap=0mm) / BDR(DH5), 2441 MHz

EUT: Helmet Mounted Wireless Headset; Type: NYSNO-10; Serial: 5002401

Mode: Bluetooth (fixed frequency, BDR, DH5) (UID: 0, Frame Length in ms: 0; PAR: 0; PMF: 1); **Frequency: 2441 MHz; Crest Factor: 1.0**
Medium: HSL2450(1711); Medium parameters used: $f = 2441$ MHz; $\sigma = 1.847$ S/m; $\epsilon_r = 37.60$; $\rho = 1000$ kg/m³

Measurement Standard: DASYS5 (IEEE/IEC/ANSI C63.19-2007)

DASY Configuration: -Probe: EX3DV4 - SN3907; ConvF(7.37, 7.37, 7.37); Calibrated: 2017/02/27; -Electronics: DAE4 Sn554; Calibrated: 2017/05/18
-Sensor-Surface: 2mm (Mechanical Surface Detection (Locations From Previous Scan Used)), Sensor-Surface: 2mm (Mechanical Surface Detection), $z = 1.0, 31.0$
-Phantom: SAM-Twin with CRP; Type: QD000P40CA; Serial: TP:1273; Phantom section: Flat Section -DASY52.52.8.8(1222); SEMCAD X 14.6.10(7331)

helmet-mounted,no.mic/h21,2441,outer-ant-tilt&touch,bdr(dh5)

Area:72x72,12 (7x7x1): Measurement grid: $dx=12$ mm, $dy=12$ mm; Maximum value of SAR (measured) = 0.919 W/kg

Area:72x72,12 (61x61x1): Interpolated grid: $dx=1.200$ mm, $dy=1.200$ mm; Maximum value of SAR (interpolated) = 1.16 W/kg

Zoom:30x30x30,5 (7x7x7)/Cube 0: Measurement grid: $dx=5$ mm, $dy=5$ mm, $dz=5$ mm;

Reference Value = 22.83 V/m; Power Drift = -0.04 dB; Maximum value of SAR (measured) = 1.04 W/kg; Peak SAR (extrapolated) = 1.42 W/kg

SAR(1g) = 0.717 W/kg; SAR(10 g) = 0.360 W/kg

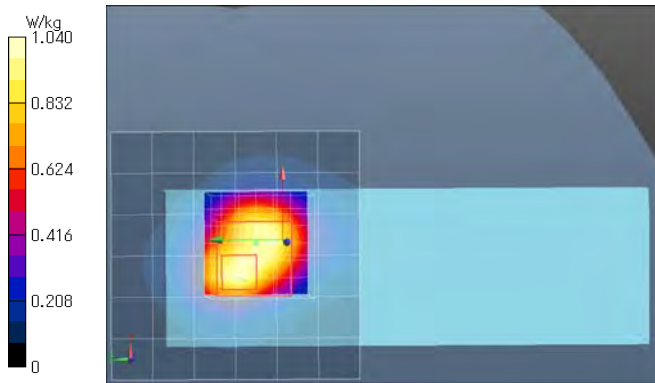

Remarks: * Date tested: 2017/11/14, Tested by: Hiroshi Naka; Tested place: No.7 shielded room,
* liquid depth: 183 mm (*Flat); Position: distance of EUT to phantom: 0 mm (2 mm to liquid); ambient: (24~25) deg.C. / (40~50) %RH,
* liquid temperature: 24.0(start)/24.0(end)/24.0(in check) deg.C.; * White cubic: zoom scan area, Red cubic: big=SAR(10g)/small=SAR(1g)

Plot 3-8: Front-tilt (No microphone) & touch (gap=0mm) / EDR(2DH5), 2402 MHz

EUT: Helmet Mounted Wireless Headset; Type: NYSNO-10; Serial: 5002401

Mode: Bluetooth (fixed frequency, EDR, 2DH5) (UID: 0, Frame Length in ms: 0; PAR: 0; PMF: 1); **Frequency: 2402 MHz; Crest Factor: 1.0**
Medium: HSL2450(1711); Medium parameters used: $f = 2402$ MHz; $\sigma = 1.795$ S/m; $\epsilon_r = 37.77$; $\rho = 1000$ kg/m³

Measurement Standard: DASYS5 (IEEE/IEC/ANSI C63.19-2007)

DASY Configuration: -Probe: EX3DV4 - SN3907; ConvF(7.37, 7.37, 7.37); Calibrated: 2017/02/27; -Electronics: DAE4 Sn554; Calibrated: 2017/05/18
-Sensor-Surface: 2mm (Mechanical Surface Detection (Locations From Previous Scan Used)), Sensor-Surface: 2mm (Mechanical Surface Detection), $z = 1.0, 31.0$
-Phantom: SAM-Twin with CRP; Type: QD000P40CA; Serial: TP:1273; Phantom section: Flat Section -DASY52.52.8.8(1222); SEMCAD X 14.6.10(7331)

helmet-mounted,no.mic/h22,2402,outer-ant-tilt&touch,edr(2dh5)

Area:72x72,12 (7x7x1): Measurement grid: $dx=12$ mm, $dy=12$ mm; Maximum value of SAR (measured) = 0.751 W/kg

Area:72x72,12 (61x61x1): Interpolated grid: $dx=1.200$ mm, $dy=1.200$ mm; Maximum value of SAR (interpolated) = 0.974 W/kg

Zoom:30x30x30,5 (7x7x7)/Cube 0: Measurement grid: $dx=5$ mm, $dy=5$ mm, $dz=5$ mm;

Reference Value = 21.37 V/m; Power Drift = -0.09 dB; Maximum value of SAR (measured) = 0.840 W/kg; Peak SAR (extrapolated) = 1.18 W/kg

SAR(1g) = 0.564 W/kg; SAR(10 g) = 0.294 W/kg

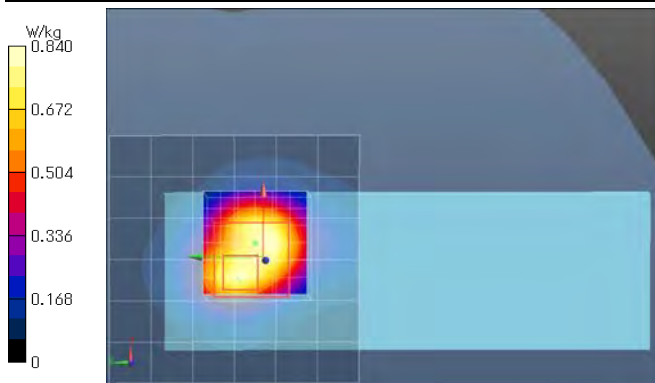

Remarks: * Date tested: 2017/11/14, Tested by: Hiroshi Naka; Tested place: No.7 shielded room,
* liquid depth: 183 mm (*Flat); Position: distance of EUT to phantom: 0 mm (2 mm to liquid); ambient: (24~25) deg.C. / (40~50) %RH,
* liquid temperature: 24.0(start)/24.0(end)/24.0(in check) deg.C.; * White cubic: zoom scan area, Red cubic: big=SAR(10g)/small=SAR(1g)

UL Japan, Inc.

Shonan EMC Lab.

1-22-3 Megumigaoka, Hiratsuka-shi, Kanagawa-ken, 259-1220 JAPAN
Telephone: +81 463 50 6400 / Facsimile: +81 463 50 6401

Appendix 2-2: SAR measurement data / Other SAR(1g) Plots (cont'd)

Plot 3-9: Front-tilt (No microphone) & touch (gap=0mm) / EDR(2DH5), 2480 MHz

EUT: Helmet Mounted Wireless Headset; Type: NYSNO-10; Serial: 5002401

Mode: Bluetooth (fixed frequency, EDR, 2DH5) (UID: 0, Frame Length in ms: 0; PAR: 0; PMF: 1); **Frequency: 2480 MHz; Crest Factor: 1.0**

Medium: HSL2450(1711); Medium parameters used: f = 2480 MHz; $\sigma = 1.894$ S/m; $\epsilon_r = 37.42$; $\rho = 1000$ kg/m³

Measurement Standard: DASY5 (IEEE/IEC/ANSI C63.19-2007)

DASY Configuration: -Probe: EX3DV4 - SN3907; ConvF(7.37, 7.37, 7.37); Calibrated: 2017/02/27; -Electronics: DAE4 Sn554; Calibrated: 2017/05/18
-Sensor-Surface: 2mm (Mechanical Surface Detection (Locations From Previous Scan Used)), Sensor-Surface: 2mm (Mechanical Surface Detection), z = 1.0, 31.0
-Phantom: SAM-Twin with CRP; Type: QD000P40CA; Serial: TP:1273; Phantom section: Flat Section -DASY52 52.8.8(1222); SEMCAD X 14.6.10(7331)

helmet-mounted,no.mic/h23,2480,outer-ant-tilt&touch,edr(2dh5)/

Area:72x72,12 (7x7x1): Measurement grid: dx=12mm, dy=12mm; Maximum value of SAR (measured) = 0.562 W/kg

Area:72x72,12 (61x61x1): Interpolated grid: dx=1.200 mm, dy=1.200 mm; Maximum value of SAR (interpolated) = 0.686 W/kg

Zoom:30x30x30,5 (7x7x7)/Cube 0: Measurement grid: dx=5mm, dy=5mm, dz=5mm;

Reference Value = 17.41 V/m; Power Drift = -0.07 dB; Maximum value of SAR (measured) = 0.651 W/kg; Peak SAR (extrapolated) = 0.888 W/kg

SAR(1 g) = 0.439 W/kg; SAR(10 g) = 0.213 W/kg

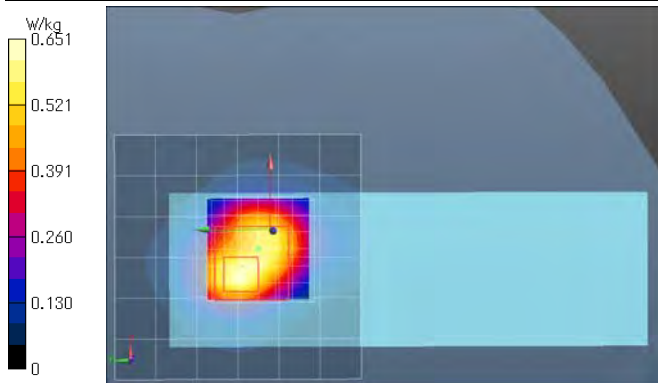

Remarks: * Date tested: 2017/11/14, Tested by: Hiroshi Naka; Tested place: No.7 shielded room,
* liquid depth: 183 mm (*Flat); Position: distance of EUT to phantom: 0 mm (2 mm to liquid); ambient: (24~25) deg.C. / (40~50) %RH,
* liquid temperature: 24.0(start)/24.0(end)/24.0(in check) deg.C.; *White cubic: zoom scan area, Red cubic: big=SAR(10g)/small=SAR(1g)

Plot 3-10: Top (No microphone) & touch (gap=0mm) / EDR(2DH5), 2441 MHz

EUT: Helmet Mounted Wireless Headset; Type: NYSNO-10; Serial: 5002401

Mode: Bluetooth (fixed frequency, EDR, 2DH5) (UID: 0, Frame Length in ms: 0; PAR: 0; PMF: 1); **Frequency: 2441 MHz; Crest Factor: 1.0**

Medium: HSL2450(1711); Medium parameters used: f = 2441 MHz; $\sigma = 1.847$ S/m; $\epsilon_r = 37.60$; $\rho = 1000$ kg/m³

Measurement Standard: DASY5 (IEEE/IEC/ANSI C63.19-2007)

DASY Configuration: -Probe: EX3DV4 - SN3907; ConvF(7.37, 7.37, 7.37); Calibrated: 2017/02/27; -DASY52 52.8.8(1222); SEMCAD X 14.6.10(7331)
-Sensor-Surface: 2mm (Mechanical Surface Detection), z = 1.0, 31.0 -Electronics: DAE4 Sn554; Calibrated: 2017/05/18
-Phantom: SAM-Twin with CRP; Type: QD000P40CA; Serial: TP:1273; Phantom section: Left Section

helmet-mounted,no.mic/h24,2441,top(ant)&touch,edr(2dh5)/

Area:72x96,12 (7x9x1): Measurement grid: dx=12mm, dy=12mm; Maximum value of SAR (measured) = 0.281 W/kg

Area:72x96,12 (61x81x1): Interpolated grid: dx=1.200 mm, dy=1.200 mm; Maximum value of SAR (interpolated) = 0.298 W/kg

Zoom:30x30x30,5 (7x8x7)/Cube 0: Measurement grid: dx=5mm, dy=5mm, dz=5mm;

Reference Value = 13.01 V/m; Power Drift = -0.07 dB; Maximum value of SAR (measured) = 0.315 W/kg; Peak SAR (extrapolated) = 0.463 W/kg

SAR(1 g) = 0.205 W/kg; SAR(10 g) = 0.104 W/kg

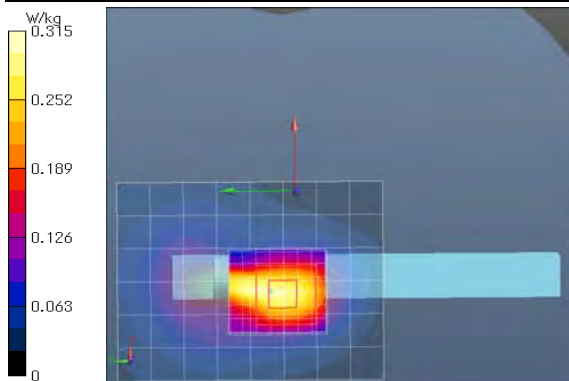

Remarks: * Date tested: 2017/11/14, Tested by: Hiroshi Naka; Tested place: No.7 shielded room,
* liquid depth: 183 mm (*Flat); Position: distance of EUT to phantom: 0 mm (2 mm to liquid); ambient: (24~25) deg.C. / (40~50) %RH,
* liquid temperature: 24.0(start)/24.0(end)/24.0(in check) deg.C.; *White cubic: zoom scan area, Red cubic: big=SAR(10g)/small=SAR(1g)

Appendix 2-2: SAR measurement data / Other SAR(1g) Plots (cont'd)

Plot 3-11: Left (No microphone) & touch (gap=0mm) / EDR(2DH5), 2441 MHz

EUT: Helmet Mounted Wireless Headset; Type: NYSNO-10; Serial: 5002401

Mode: Bluetooth (fixed frequency, EDR, 3DH5) (UID: 0, Frame Length in ms: 0; PAR: 0; PMF: 1); **Frequency: 2441 MHz; Crest Factor: 1.0**

Medium: HSL2450(1711); Medium parameters used: $f = 2441$ MHz; $\sigma = 1.842$ S/m; $\epsilon_r = 37.89$; $\rho = 1000$ kg/m³

Measurement Standard: DASY5 (IEEE/IEC/ANSI C63.19-2007)

DASY Configuration: -Probe: EX3DV4 - SN3907; ConvF(7.37, 7.37, 7.37); Calibrated: 2017/02/27; -DASY52 52.8.8(1222); SEMCAD X 14.6.10(7331)
-Sensor-Surface: 2mm (Mechanical Surface Detection), z = 1.0, 31.0 -Electronics: DAE4 Sn554; Calibrated: 2017/05/18
-Phantom: SAM-Twin with CRP; Type: QD000P40CA; Serial: TP:1273; Phantom section: Left Section

helmet-mounted/h13,2441,mic-con(no-mic)&touch,edr(2dh5)/

Area:72x72,12 (7x7x1): Measurement grid: dx=12mm, dy=12mm; Maximum value of SAR (measured) = 0.451 W/kg

Area:72x72,12 (61x61x1): Interpolated grid: dx=1.200 mm, dy=1.200 mm; Maximum value of SAR (interpolated) = 0.519 W/kg

Zoom:30x30x30,5 (7x7x7)/Cube 0: Measurement grid: dx=5mm, dy=5mm, dz=5mm;

Reference Value = 17.39 V/m; Power Drift = 0.01 dB; Maximum value of SAR (measured) = 0.541 W/kg; Peak SAR (extrapolated) = 0.733 W/kg

SAR(1 g) = 0.356 W/kg; SAR(10 g) = 0.163 W/kg

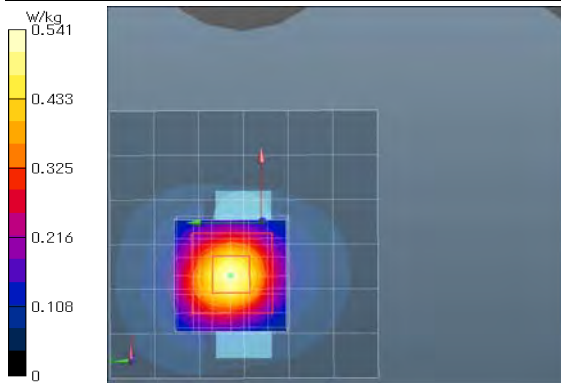

Remarks: * Date tested: 2017/11/10, Tested by: Hiroshi Naka; Tested place: No.7 shielded room,
* liquid depth: 183 mm (* Flat); Position: distance of EUT to phantom: 0 mm (2 mm to liquid); ambient: (24~25) deg.C. / (40~50) %RH,
* liquid temperature: 24.1(start)/24.1(end)/24.0(in check) deg.C.; * White cubic: zoom scan area, Red cubic: big=SAR(10g)/small=SAR(1g)

APPENDIX 3: Test instruments

Appendix 3-1: Equipment used

Control No.	Instrument	Manufacturer	Model No	Serial No	Test Item	Calibration Date * Interval(month)
KPM-08	Power meter	Anritsu	ML2495A	6K00003356	AT	2017/09/19 * 12
KPSS-04	Power sensor	Anritsu	MA2411B	012088	AT	2017/09/19 * 12
KAT10-S3	Attenuator	Agilent	8490D 010	50924	AT	2016/12/21 * 12
SRENT-08	Spectrum Analyzer	Agilent	E4448A	MY50180019	AT	2017/10/12 * 12

*. AT (antenna terminal conducted power measurement) was measured October 26, 2017. (Refer to Section 6 in this report.)

Control No.	Instrument	Manufacturer	Model No	Serial No	Test Item	Calibration Date * Interval(month)
COTS-SSAR-02	DASY52	Schmid&Partner Engineering AG	DASY52(ver.52.8.8(1222))	-	SAR	-
COTS-SSEP-02	Dielectric assessment kit	Schmid&Partner Engineering AG	DAK(ver1.10.317.11)	-	SAR	-
SSAR-02	SAR measurement system	Schmid&Partner Engineering AG	DASY5	1324	SAR	Pre Check
SSRBT-02	SAR robot	Schmid&Partner Engineering AG	TX60 Lspeag	F12/5L2QA1/A/01	SAR	2017/09/28 * 12
KDAE-R01	Data Acquisition Electronics	Schmid&Partner Engineering AG	DAE4	554	SAR	2017/05/18 * 12
SPB-02	Dosimetric E-Field Probe	Schmid&Partner Engineering AG	EX3DV4	3907	SAR	2017/02/27 * 12
KSDA-01	Dipole Antenna	Schmid&Partner Engineering AG	D2450V2	822	SAR	2017/01/11 * 12
KPFL-01	Flat Phantom	Schmid&Partner Engineering AG	Oval flat phantom ELI 4.0	1059	SAR	2017/08/25 * 12
SSNA-01	Network Analyzer	Agilent	8753ES	US39171777	SAR	2016/12/15 * 12
SEPP-02	Dielectric probe	Schmid&Partner Engineering AG	DAK3.5	1129	SAR	2017/08/08 * 12
KSG-08	Signal Generator	Rohde & Schwarz	SMT06	100763	SAR	2107/08/23 * 12
KPA-12	RF Power Amplifier	MILMEGA	AS2560-50	1018582	SAR	Pre Check
KCPL-07	Directional Coupler	Pulsar Microwave Corp.	CCS30-B26	0621	SAR	Pre Check
KPM-06	Power Meter	Rohde & Schwarz	NRVD	101599	SAR	2017/09/19 * 12
KIU-08	Power sensor	Rohde & Schwarz	NRV-Z4	100372	SAR	2017/09/19 * 12
KIU-09	Power sensor	Rohde & Schwarz	NRV-Z4	100371	SAR	2017/09/19 * 12
KAT10-P1	Attenuator	Weinschel	24-10-34	BY5927	SAR	2016/12/21 * 12
KPM-05	Power meter	Agilent	E4417A	GB41290718	SAR	2017/05/08 * 12
KPSS-01	Power sensor	Agilent	E9327A	US40440544	SAR	2017/05/08 * 12
SAT20-SAR1	Attenuator	TME	SFA-01AXPJ-20	-	SAR	2016/12/21 * 12
SCC-SAR2	Coaxial Cable	HUBER+SUHNER	SF104A/11PC3542/11N451/4M	MY699/4A	SAR	Pre Check
KRU-01	Ruler(300mm)	Shinwa	13134	-	SAR	2017/02/02 * 12
KRU-02	Ruler(150mm,L)	Shinwa	12103	-	SAR	2017/02/02 * 12
KRU-05	Ruler(100x50mm,L)	Shinwa	12101	-	SAR	2017/05/23 * 12
KOS-13	Digital thermometer	HANNA	Checktemp-2	KOS-13	SAR	2016/12/13 * 12
KOS-14	Thermo-Hygrometer data logger	SATO KEIRYOKI	SK-L200THII α / SK-LTHII α-2	015246/08169	SAR	2016/12/13 * 12
SOS-11	Humidity Indicator	A&D	AD-5681	4063424	SAR	2016/12/13 * 12
SOS-12	Digital thermometer	HANNA	Checktemp-4	SOS-12	SAR	2017/02/21 * 12
SOS-SAR1	Digital thermometer	LKMelectronic	DTM3000	3171	SAR	2016/10/28 * 12
SSA-04	Spectrum Analyzer	Advantest	R3272	101100994	SAR(moni.)	Pre Check
KSDH-01	Device holder	Schmid&Partner Engineering AG	Mounting device for transmitter	-	SAR	2017/09/28 * 12
SWTR-03	DI water	MonotaRo	34557433	-	SAR	Pre Check
SALC-01	Primepure Ethanol	Kanto Chemical Co., Inc.	14032-79	-	SAR	Pre Check
KSLH245-01	Tissue simulation liquid (2450MHz.head)	Schmid&Partner Engineering AG	HSL2450V2	SL AAH 245 BA	SAR	Pre Check

The expiration date of calibration is the end of the expired month.

As for some calibrations performed after the tested dates, those test equipment have been controlled by means of an unbroken chains of calibrations.

All equipment is calibrated with valid calibrations. Each measurement data is traceable to the national or international standards.

[Test Item] SAR: Specific Absorption Rate, AT: Antenna terminal conducted power

Appendix 3-2: Configuration and peripherals

These measurements were performed with the automated near-field scanning system DASY5 from Schmid & Partner Engineering AG (SPEAG). The system is based on a high precision robot, which positions the probes with a positional repeatability of better than ± 0.02 mm. Special E- and H-field probes have been developed for measurements close to material discontinuity, the sensors of which are directly loaded with a Schottky diode and connected via highly resistive lines to the data acquisition unit. The SAR measurements were conducted with the dosimetry probes EX3DV4 (manufactured by SPEAG), designed in the classical triangular configuration and optimized for dosimetric evaluation.

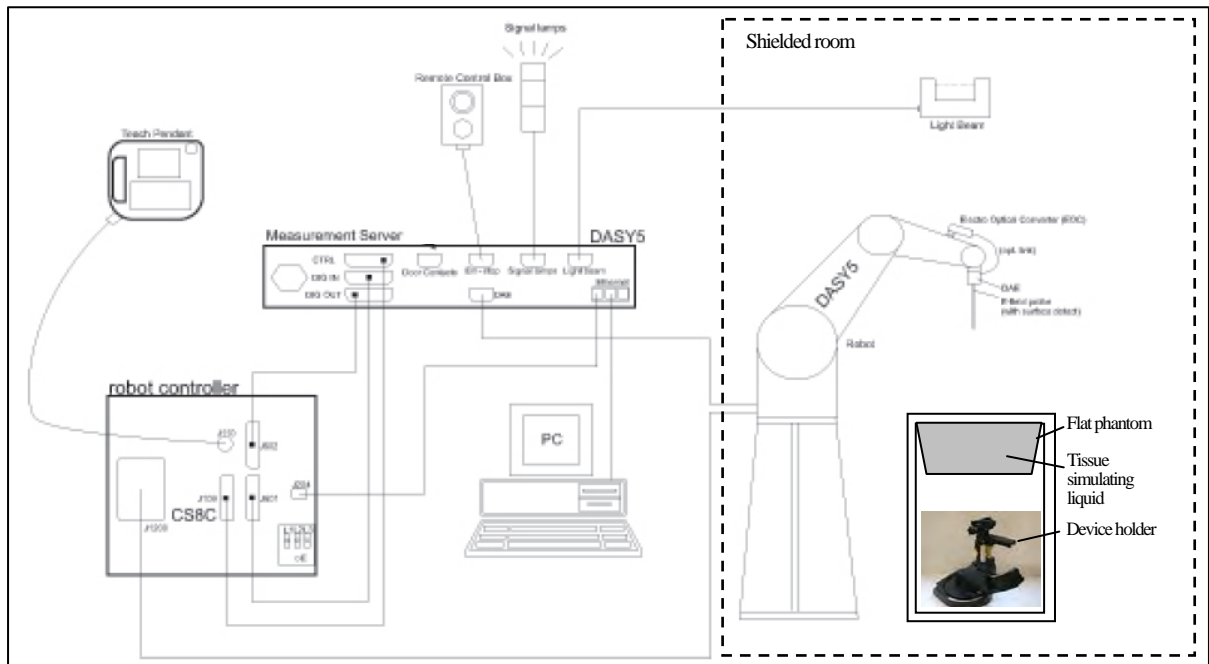

The DASY5 system for performing compliance tests consist of the following items:

1	A standard high precision 6-axis robot (Stäubli TX/RX family) with controller, teach pendant and software. An arm extension for accommodating the data acquisition electronics (DAE).
2	An isotropic field probe optimized and calibrated for the targeted measurement.
3	A data acquisition electronics (DAE) which performs the signal amplification, signal multiplexing, AD-conversion, offset measurements, mechanical surface detection, collision detection, etc. The unit is battery powered with standard or rechargeable batteries. The signal is optically transmitted to the EOC.
4	The Electro-optical converter (EOC) performs the conversion from optical to electrical signals for the digital communication to the DAE. To use optical surface detection, a special version of the EOC is required. The EOC signal is transmitted to the measurement server.
5	The function of the measurement server is to perform the time critical tasks such as signal filtering, control of the robot operation and fast movement interrupts.
6	The Light Beam used is for probe alignment. This improves the (absolute) accuracy of the probe positioning.
7	A computer running Win7 professional operating system and the DASY5 software.
8	Remote control and teach pendant as well as additional circuitry for robot safety such as warning lamps, etc.
9	The phantom.
10	The device holder for EUT. (low-loss dielectric palette) (*. when it was used.)
11	Tissue simulating liquid mixed according to the given recipes.
12	Validation dipole kits allowing to validate the proper functioning of the system.

Appendix 3-3: Test system specification

TX60 Lspeag robot/CS8Cspeag-TX60 robot controller

- Number of Axes : 6
- Repeatability : $\pm 0.02\text{mm}$
- Manufacture : Stäubli Unimation Corp.

DASY5 Measurement server

- Features : The DASY5 measurement server is based on a PC/104 CPU board with a 400MHz intel ULV Celeron, 128MB chip-disk and 128MB RAM. The necessary circuits for communication with the DAE4 electronics box, as well as the 16 bit AD converter system for optical detection and digital I/O interface are contained on the DASY5 I/O board, which is directly connected to the PC/104 bus of the CPU board.
- Calibration : No calibration required.
- Manufacture : Schmid & Partner Engineering AG

Data Acquisition Electronic (DAE)

- Features : Signal amplifier, multiplexer, A/D converter and control logic. Serial optical link for communication with DASY5 embedded system (fully remote controlled). 2 step probe touch detector for mechanical surface detection and emergency robot stop (not in -R version)
- Measurement Range : $1\mu\text{V}$ to $> 200\text{mV}$ (16bit resolution and 2 range settings: 4mV, 400mV)
- Input Offset voltage : $< 1\mu\text{V}$ (with auto zero)
- Input Resistance : $200\text{M}\Omega$
- Battery Power : $> 10\text{hr}$ of operation (with two 9V battery)
- Manufacture : Schmid & Partner Engineering AG

Electro-Optical Converter (EOC61)

- Manufacture : Schmid & Partner Engineering AG

Light Beam Switch (LB5/80)

- Manufacture : Schmid & Partner Engineering AG

SAR measurement software

- Item : Dosimetric Assessment System DASY5
- Software version : DASY52, V8.2 B969
- Manufacture : Schmid & Partner Engineering AG

E-Field Probe

- Model : **EX3DV4 (serial number: 3907)**
- Construction : Symmetrical design with triangular core. Built-in shielding against static charges. PEEK enclosure material (resistant to organic solvents, e.g., DGBE).
- Frequency : 10MHz to 6GHz, Linearity: $\pm 0.2\text{ dB}$ (30MHz to 6GHz)
- Conversion Factors : 2.45, 5.2, 5.25, 5.5, 5.6, 5.75, 5.8 GHz (Head)
2.45, 5.25, 5.6, 5.75 GHz (Body)
- Directivity : $\pm 0.3\text{ dB}$ in HSL (rotation around probe axis)
 $\pm 0.5\text{ dB}$ in tissue material (rotation normal to probe axis)
- Dynamic Range : $10\mu\text{W/g}$ to $> 100\text{ mW/g}$; Linearity: $\pm 0.2\text{ dB}$ (noise: typically $< 1\mu\text{W/g}$)
- Dimension : Overall length: 330mm (Tip: 20mm)
Tip diameter: 2.5mm (Body: 12mm)
Typical distance from probe tip to dipole centers: 1mm
- Application : High precision dosimetric measurement in any exposure scenario (e.g., very strong gradient fields). Only probe which enables compliance testing for frequencies up to 6GHz with precision of better 30%.
- Manufacture : Schmid & Partner Engineering AG

Phantom

- Type : **ELI 4.0 oval flat phantom**
- Shell Material : Fiberglass
- Shell Thickness : Bottom plate: $2 \pm 0.2\text{mm}$
- Dimensions : Bottom elliptical: $600 \times 400\text{mm}$, Depth: 190mm (Volume: Approx. 30 liters)
- Manufacture : Schmid & Partner Engineering AG

Device Holder

- Urethane foam
- KSDH-01: In combination with the ELI4, the Mounting Device enables the rotation of the mounted transmitter device in spherical coordinates. Transmitter devices can be easily and accurately positioned. The low-loss dielectric urethane foam was used for the mounting section of device holder.
- Material : POM
- Manufacture : Schmid & Partner Engineering AG

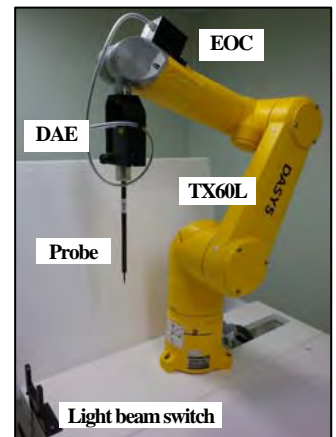

Appendix 3-4: Simulated tissue composition and parameter confirmation

Liquid type	Head
Control No.	KSLH245-01
Model No. / Product No.	HSL2450V2 /SL AAH 245 BA
Ingredient: Mixture(%)	Water: 52-75%, DGBE: 25-48%, NaCl: <1.0%
Manufacture	Schmid & Partner Engineering AG

*. The dielectric parameters were checked prior to assessment using the DAK3.5 dielectric probe kit.

Measured date	Frequency [MHz]	Liquid type	Ambient [deg.C.] / [%RH]	Liquid temp. [deg.C.]	Liquid Depth [mm]	Liquid parameters (*a)						ASAR					
						Permittivity (εr) [-]			Conductivity [S/m]			Target	Limit	Target	Limit	(1g) [%] (*b)	(10g) [%] (*b)
						Target	Measured		Target	Measured							
November 10, 2017	2450	Head	24.7/42	24.0	(183)	39.2	37.89	-3.3	±5%	1.80	1.846	+2.6	±5%	+1.99	+1.20		
November 14, 2017	2450	Head	24.5/43	24.0	(183)	39.2	37.53	-4.3	±5%	1.80	1.853	+3.0	±5%	+2.38	+1.44		

*a. The target value is a parameter defined in Appendix A of KDB865664 D01 (v01r04), the dielectric parameters are given at 2000, 2450 and 3000MHz. Parameters for the frequencies between 2000-3000MHz were obtained using linear interpolation.

Standard							
f (MHz)	Head Tissue		Body Tissue		f (MHz)	Body Tissue	
	εr	σ [S/m]	εr	σ [S/m]		εr	σ [S/m]
(1800)-2000	40.0	1.40	53.3	1.52	3000	38.5	2.40
2450	39.2	1.80	52.7	1.95			

*b. The coefficients are parameters defined in IEEE Std. 1528-2013.

$$\Delta SAR(1g) = C_{\epsilon r} \times \Delta \epsilon r + C_{\sigma} \times \Delta \sigma, C_{\epsilon r} = -7.854E-4 \times f^3 + 9.402E-3 \times f^2 - 2.742E-2 \times f + 0.2026 / C_{\sigma} = 9.804E-3 \times f^3 - 8.661E-2 \times f^2 + 2.981E-2 \times f + 0.7829$$

$$\Delta SAR(10g) = C_{\epsilon r} \times \Delta \epsilon r + C_{\sigma} \times \Delta \sigma, C_{\epsilon r} = 3.456 \times 10^{-3} \times f^3 - 3.531 \times 10^{-2} \times f^2 + 7.675 \times 10^{-2} \times f + 0.1860 / C_{\sigma} = 4.479 \times 10^{-3} \times f^3 - 1.586 \times 10^{-2} \times f^2 - 0.1972 \times f + 0.7717$$

Appendix 3-5: Daily check results

Prior to the SAR assessment of EUT, the Daily check was performed to test whether the SAR system was operating within its target of ±10%. The Daily check results are in the table below.

Daily check results																				
Date	Frequency [MHz]	Liquid Type	Daily check target & measured																	
			SAR (1g) [W/kg] (*d)									SAR (10g) [W/kg] (*d)								
			Meas. (*c)	ASAR-correct	1W scaled	Target Cal. (*e)	STD (*f)	Deviation Cal. [%]	STD [%]	Limit [%]	Pass ?	Meas. (*c)	ASAR-correct	1W scaled	Target Cal. (*e)	STD (*f)	Deviation Cal. [%]	STD [%]	Limit [%]	Pass ?
November 10, 2017	2450	Head	14.	13.72	54.88	(51)	52.4	(+7.6)	+4.8	±10	Pass	6.44	6.36	25.44	(24)	24.0	(+6.1)	+6.1	±10	Pass
November 14, 2017	2450	Head	13.9	13.57	54.28	(51)	54.28	(+6.4)	+3.6	±10	Pass	6.4	6.31	25.24	(24)	24.0	(+5.2)	+5.2	±10	Pass

*. Calculating formula: ΔSAR corrected SAR (1g,10g) (W/kg) = (Observed SAR(1g,10g) (W/kg)) × (100 - (ΔSAR(%)) / 100

*c. The "Meas. (Measured)" SAR value is obtained at 250 mW for 2450MHz.

*d. The measured SAR value of Daily check was compensated for tissue dielectric deviations (ASAR) and scaled to 1W of output power in order to compare with the manufacture's calibration target value which was normalized.

*e. The target value is a parameter defined in the calibration data sheet of D2450V2 dipole calibrated by Schmid & Partner Engineering AG (Certification No. D2450V2-822_Jan17, the data sheet was filed in this report).

*f. The target value (normalized to 1W) is defined in IEEE Std.1528.

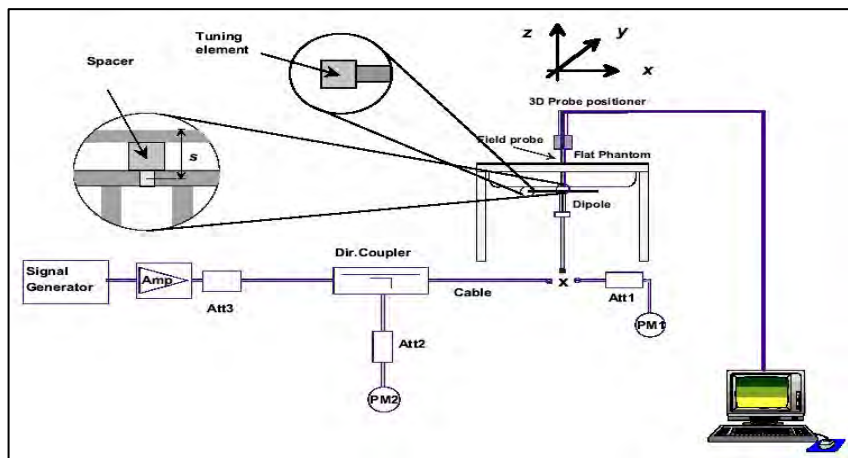

Test setup for the system performance check

Appendix 3-6: Daily check measurement data

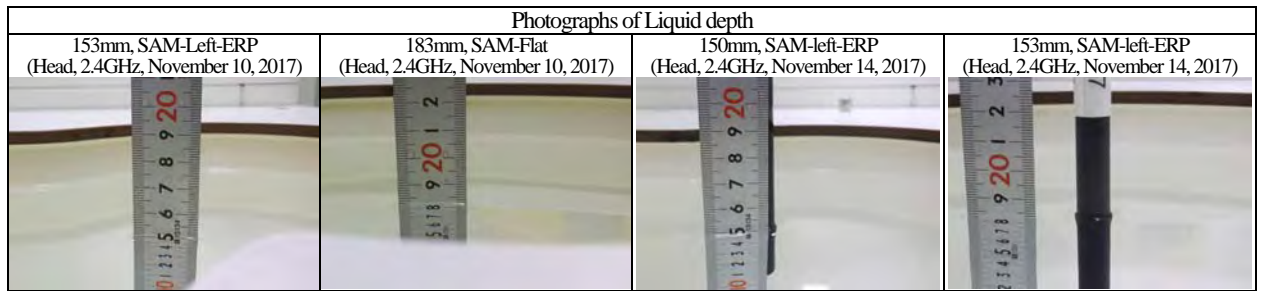

(November 10, 2017) EUT: Dipole(2.45GHz)(sn822); Type: D2450V2; Serial: 822; Forward conducted power: 250mW

Communication System: CW (*: UID:0; Frame Length in ms: 0; PAR: 0; PMF: 1); **Frequency: 2450 MHz; Crest Factor: 1.0**

Medium: HSL2450(1711); Medium parameters used: f = 2450 MHz; $\sigma = 1.846$ S/m; $\epsilon_r = 37.89$; $\rho = 1000$ kg/m³

Measurement Standard: DASYS (IEEE/IEC/ANSI C63.19-2007)

DASY Configuration: -Probe: EX3DV4 - SN3907; ConvF(7.37, 7.37, 7.37); Calibrated: 2017/02/27; -DASY52 52.8.8(1222); SEMCAD X 14.6.10(7331)
 -Sensor-Surface: 2mm (Mechanical Surface Detection), z = 1.0, 31.0, 186.0 -Electronics: DAE4 Sn554; Calibrated: 2017/05/18
 -Phantom: SAM-Twin with CRP; Type: QD000P40CA; Serial: TP:1273; Phantom section: Flat Section

Area Scan:60x60,stp15 (5x5x1): Measurement grid: dx=15mm, dy=15mm; Maximum value of SAR (measured) = 21.3 W/kg

Area Scan:60x60,stp15 (41x41x1): Interpolated grid: dx=1.500 mm, dy=1.500 mm; Maximum value of SAR (interpolated) = 21.6 W/kg

Z Scan:185,stp5(mm) (1x1x38): Measurement grid: dx=20mm, dy=20mm, dz=5mm; Maximum value of SAR (measured) = 21.6 W/kg

Zoom Scan:30x30x30,stp5,5,5 (7x7x7)/Cube 0: Measurement grid: dx=5mm, dy=5mm, dz=5mm;

Reference Value = 108.9 V/m; Power Drift = -0.00 dB; Maximum value of SAR (measured) = 21.6 W/kg; Peak SAR (extrapolated) = 29.4 W/kg

SAR(1 g) = 14 W/kg; SAR(10 g) = 6.44 W/kg

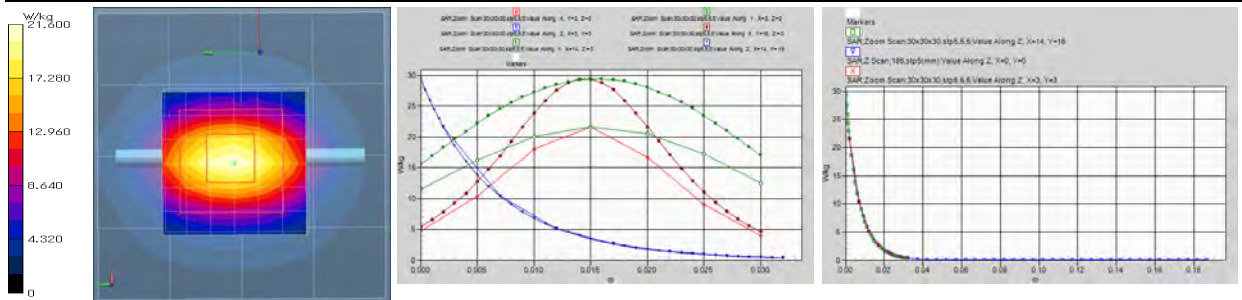

Remarks: * Date tested: 2017/11/10; Tested by: Hiroshi Naka; Tested place: No.7 shielded room,
 * liquid depth: 183 mm (*Flat Section) (Left ERP: 150mm); Position: distance of dipole to phantom: 8mm (10mm to liquid); ambient: 24.9 deg.C. /
 42 %RH,
 * liquid temperature: 23.8(start)/23.8(end)/24.0(in check) deg.C.; *White cubic: zoom scan area, Red cubic: big=SAR(10g)/small=SAR(1g)

(November 14, 2017) EUT: Dipole(2.45GHz)(sn822); Type: D2450V2; Serial: 822; Forward conducted power: 250mW

Communication System: CW (*: UID:0; Frame Length in ms: 0; PAR: 0; PMF: 1); **Frequency: 2450 MHz; Crest Factor: 1.0**

Medium: HSL2450(1711); Medium parameters used: f = 2450 MHz; $\sigma = 1.853$ S/m; $\epsilon_r = 37.53$; $\rho = 1000$ kg/m³

Measurement Standard: DASYS (IEEE/IEC/ANSI C63.19-2007)

DASY Configuration: -Probe: EX3DV4 - SN3907; ConvF(7.37, 7.37, 7.37); Calibrated: 2017/02/27; -DASY52 52.8.8(1222); SEMCAD X 14.6.10(7331)
 -Sensor-Surface: 2mm (Mechanical Surface Detection), z = 1.0, 31.0, 186.0 -Electronics: DAE4 Sn554; Calibrated: 2017/05/18
 -Phantom: SAM-Twin with CRP; Type: QD000P40CA; Serial: TP:1273; Phantom section: Flat Section

Area Scan:60x60,stp15 (5x5x1): Measurement grid: dx=15mm, dy=15mm; Maximum value of SAR (measured) = 21.1 W/kg

Area Scan:60x60,stp15 (41x41x1): Interpolated grid: dx=1.500 mm, dy=1.500 mm; Maximum value of SAR (interpolated) = 21.5 W/kg

Z Scan:185,stp5(mm) (1x1x38): Measurement grid: dx=20mm, dy=20mm, dz=5mm; Maximum value of SAR (measured) = 21.5 W/kg

Zoom Scan:30x30x30,stp5,5,5 (7x7x7)/Cube 0: Measurement grid: dx=5mm, dy=5mm, dz=5mm;

Reference Value = 108.2 V/m; Power Drift = -0.02 dB; Maximum value of SAR (measured) = 21.5 W/kg; Peak SAR (extrapolated) = 29.3 W/kg

SAR(1 g) = 13.9 W/kg; SAR(10 g) = 6.4 W/kg

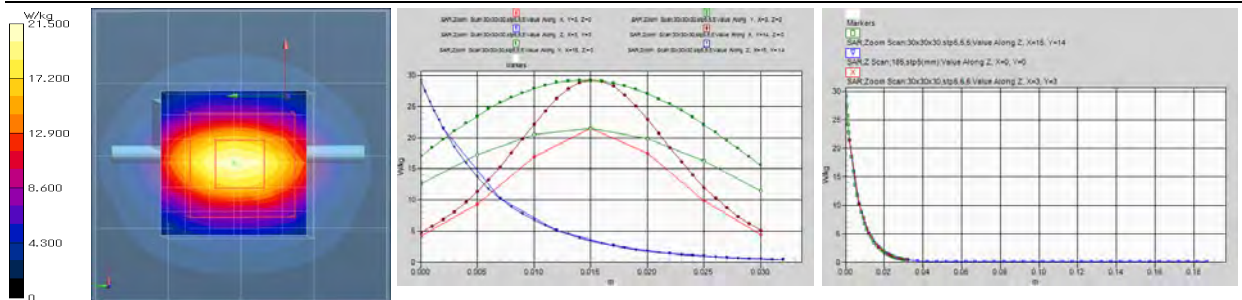

Remarks: * Date tested: 2017/11/17; Tested by: Hiroshi Naka; Tested place: No.7 shielded room,
 * liquid depth: 183 mm (*Flat Section) (Left ERP: 150mm); Position: distance of dipole to phantom: 8mm (10mm to liquid); ambient: 24.9 deg.C. /
 42 %RH,
 * liquid temperature: 23.8(start)/23.8(end)/24.0(in check) deg.C.; *White cubic: zoom scan area, Red cubic: big=SAR(10g)/small=SAR(1g)

UL Japan, Inc.

Shonan EMC Lab.

1-22-3 Megumigaoka, Hiratsuka-shi, Kanagawa-ken, 259-1220 JAPAN
 Telephone: +81 463 50 6400 / Facsimile: +81 463 50 6401

Appendix 3-7: Daily check uncertainty

Uncertainty of daily check (2.4~6GHz) (*:ε&σ tolerance: ≤±5%, DAK3.5, CW) (v08)							1g SAR	10g SAR	
Combined measurement uncertainty of the measurement system (k=1)							± 11.0 %	± 10.9 %	
Expanded uncertainty (k=2)							± 22.1 %	± 21.8 %	
	Error Description (v08)	Uncertainty Value	Probability distribution	Divisor	ci (1g)	ci (10g)	ui (1g)	ui (10g)	Vi, veff
A	Measurement System (DASY5)						(std. uncertainty)	(std. uncertainty)	
1	Probe Calibration Error	±6.55 %	Normal	1	1	1	±6.55 %	±6.55 %	∞
2	Axial isotropy error	±4.7 %	Rectangular	√3	√0.5	√0.5	±1.9 %	±1.9 %	∞
3	Hemispherical isotropy error	±9.6 %	Rectangular	√3	0	0	0 %	0 %	∞
4	Probe linearity	±4.7 %	Rectangular	√3	1	1	±2.7 %	±2.7 %	∞
5	Probe modulation response (CW)	±0.0 %	Rectangular	√3	1	1	0 %	0 %	∞
6	System detection limit	±1.0 %	Rectangular	√3	1	1	±0.6 %	±0.6 %	∞
7	Boundary effects	±4.8 %	Rectangular	√3	1	1	±2.8 %	±2.8 %	∞
8	System readout electronics (DAE)	±0.3 %	Normal	1	1	1	±0.3 %	±0.3 %	∞
9	Response Time Error (<5ms/100ms wait)	±0.0 %	Rectangular	√3	1	1	0 %	0 %	∞
10	Integration Time Error (CW)	±0.0 %	Rectangular	√3	1	1	0 %	0 %	∞
11	RF ambient conditions-noise	±3.0 %	Rectangular	√3	1	1	±1.7 %	±1.7 %	∞
12	RF ambient conditions-reflections	±3.0 %	Rectangular	√3	1	1	±1.7 %	±1.7 %	∞
13	Probe positioner mechanical tolerance	±3.3 %	Rectangular	√3	1	1	±1.9 %	±1.9 %	∞
14	Probe positioning with respect to phantom shell	±6.7 %	Rectangular	√3	1	1	±3.9 %	±3.9 %	∞
15	Max. SAR evaluation (Post-processing)	±4.0 %	Rectangular	√3	1	1	±2.3 %	±2.3 %	∞
B	Test Sample Related								
16	Deviation of the experimental source	±3.5 %	Normal	1	1	1	±3.5 %	±3.5 %	∞
17	Dipole to liquid distance (10mm±0.2mm,<2deg.)	±2.0 %	Rectangular	√3	1	1	±1.2 %	±1.2 %	∞
18	Drift of output power (measured, <0.2dB)	±2.3 %	Rectangular	√3	1	1	±1.3 %	±1.3 %	∞
C	Phantom and Setup								
19	Phantom uncertainty	±2.0 %	Rectangular	√3	1	1	±1.2 %	±1.2 %	∞
20	Algorithm for correcting SAR (ε',σ: ≤5%)	±1.2 %	Normal	1	1	0.84	±1.2 %	±0.97 %	∞
21	Liquid conductivity (meas.) (DAK3.5)	±3.0 %	Normal	1	0.78	0.71	±2.3 %	±2.1 %	∞
22	Liquid permittivity (meas.) (DAK3.5)	±3.1 %	Normal	1	0.23	0.26	±0.7 %	±0.8 %	∞
23	Liquid Conductivity-temp.uncertainty (≤2deg.C.)	±5.3 %	Rectangular	√3	0.78	0.71	±2.4 %	±2.2 %	∞
24	Liquid Permittivity-temp.uncertainty (≤2deg.C.)	±0.9 %	Rectangular	√3	0.23	0.26	±0.1 %	±0.1 %	∞
	Combined Standard Uncertainty						±11.0 %	±10.9 %	
	Expanded Uncertainty (k=2)						±22.1 %	±21.8 %	

*. This measurement uncertainty budget is suggested by IEEE Std. 1528(2013) and determined by Schmid & Partner Engineering AG (DASY5 Uncertainty Budget).

Appendix 3-8: Calibration certificate: E-Field Probe (EX3DV4)

**Calibration Laboratory of
 Schmid & Partner
 Engineering AG**
 Zeughausstrasse 43, 8004 Zurich, Switzerland



S Schweizerischer Kalibrierdienst
C Service suisse d'étalonnage
S Servizio svizzero di taratura
 Swiss Calibration Service

Accredited by the Swiss Accreditation Service (SAS)
 The Swiss Accreditation Service is one of the signatories to the EA
 Multilateral Agreement for the recognition of calibration certificates

Accreditation No.: **SCS 0108**

Client **UL Japan (Vitec)**

Certificate No: **EX3-3907_Feb17**

CALIBRATION CERTIFICATE

Object: **EX3DV4 - SN:3907**

Calibration procedure(s): **QA CAL-01.v9, QA CAL-14.v4, QA CAL-23.v5, QA CAL-25.v6
 Calibration procedure for dosimetric E-field probes**

Calibration date: **February 27, 2017**

This calibration certificate documents the traceability to national standards, which realize the physical units of measurements (SI).
 The measurements and the uncertainties with confidence probability are given on the following pages and are part of the certificate.

All calibrations have been conducted in the closed laboratory facility: environment temperature (22 ± 3)°C and humidity < 70%.

Calibration Equipment used (M&TE critical for calibration)

Primary Standards	ID	Cal Date (Certificate No.)	Scheduled Calibration
Power meter NRP	SN: 104778	06-Apr-16 (No. 217-02288/02289)	Apr-17
Power sensor NRP-Z91	SN: 103244	06-Apr-16 (No. 217-02288)	Apr-17
Power sensor NRP-Z91	SN: 103245	06-Apr-16 (No. 217-02289)	Apr-17
Reference 20 dB Attenuator	SN: S5277 (20x)	05-Apr-16 (No. 217-02293)	Apr-17
Reference Probe ES3DV2	SN: 3013	31-Dec-16 (No. ES3-3013_Dec16)	Dec-17
DAE4	SN: 660	7-Dec-16 (No. DAE4-660_Dec16)	Dec-17
Secondary Standards	ID	Check Date (in house)	Scheduled Check
Power meter E4419B	SN: GB41293874	06-Apr-16 (in house check Jun-16)	In house check: Jun-18
Power sensor E4412A	SN: MY41498087	06-Apr-16 (in house check Jun-16)	In house check: Jun-18
Power sensor E4412A	SN: 000110210	06-Apr-16 (in house check Jun-16)	In house check: Jun-18
RF generator HP 8648C	SN: US3642U01700	04-Aug-99 (in house check Jun-16)	In house check: Jun-18
Network Analyzer HP 8753E	SN: US37390585	18-Oct-01 (in house check Oct-16)	In house check: Oct-17

Calibrated by:	Name: Jeton Kastrati	Function: Laboratory Technician	Signature:
Approved by:	Name: Katja Pokovic	Function: Technical Manager	Signature:

Issued: February 27, 2017

This calibration certificate shall not be reproduced except in full without written approval of the laboratory.

Appendix 3-8: Calibration certificate: E-Field Probe (EX3DV4) (cont'd)

**Calibration Laboratory of
Schmid & Partner
Engineering AG**
Zeughausstrasse 43, 8004 Zurich, Switzerland



S Schweizerischer Kalibrierdienst
C Service suisse d'étalonnage
S Servizio svizzero di taratura
S Swiss Calibration Service

Accredited by the Swiss Accreditation Service (SAS)
The Swiss Accreditation Service is one of the signatories to the EA
Multilateral Agreement for the recognition of calibration certificates

Accreditation No.: **SCS 0108**

Glossary:

TSL	tissue simulating liquid
NORM _{x,y,z}	sensitivity in free space
ConvF	sensitivity in TSL / NORM _{x,y,z}
DCP	diode compression point
CF	crest factor (1/duty_cycle) of the RF signal
A, B, C, D	modulation dependent linearization parameters
Polarization ϕ	ϕ rotation around probe axis
Polarization ϑ	ϑ rotation around an axis that is in the plane normal to probe axis (at measurement center), i.e., $\vartheta = 0$ is normal to probe axis
Connector Angle	information used in DASY system to align probe sensor X to the robot coordinate system

Calibration is Performed According to the Following Standards:

- IEEE Std 1528-2013, "IEEE Recommended Practice for Determining the Peak Spatial-Averaged Specific Absorption Rate (SAR) in the Human Head from Wireless Communications Devices: Measurement Techniques", June 2013
- IEC 62209-1, "Procedure to measure the Specific Absorption Rate (SAR) for hand-held devices used in close proximity to the ear (frequency range of 300 MHz to 3 GHz)", February 2005
- IEC 62209-2, "Procedure to determine the Specific Absorption Rate (SAR) for wireless communication devices used in close proximity to the human body (frequency range of 30 MHz to 6 GHz)", March 2010
- KDB 865664, "SAR Measurement Requirements for 100 MHz to 6 GHz"

Methods Applied and Interpretation of Parameters:

- NORM_{x,y,z}:** Assessed for E-field polarization $\vartheta = 0$ ($f \leq 900$ MHz in TEM-cell; $f > 1800$ MHz: R22 waveguide). NORM_{x,y,z} are only intermediate values, i.e., the uncertainties of NORM_{x,y,z} does not affect the E²-field uncertainty inside TSL (see below ConvF).
- NORM(f)_{x,y,z} = NORM_{x,y,z} * frequency_response** (see Frequency Response Chart). This linearization is implemented in DASY4 software versions later than 4.2. The uncertainty of the frequency response is included in the stated uncertainty of ConvF.
- DCP_{x,y,z}:** DCP are numerical linearization parameters assessed based on the data of power sweep with CW signal (no uncertainty required). DCP does not depend on frequency nor media.
- PAR:** PAR is the Peak to Average Ratio that is not calibrated but determined based on the signal characteristics
- A_{x,y,z}; B_{x,y,z}; C_{x,y,z}; D_{x,y,z}; VR_{x,y,z}; A, B, C, D** are numerical linearization parameters assessed based on the data of power sweep for specific modulation signal. The parameters do not depend on frequency nor media. VR is the maximum calibration range expressed in RMS voltage across the diode.
- ConvF and Boundary Effect Parameters:** Assessed in flat phantom using E-field (or Temperature Transfer Standard for $f \leq 800$ MHz) and inside waveguide using analytical field distributions based on power measurements for $f > 800$ MHz. The same setups are used for assessment of the parameters applied for boundary compensation (alpha, depth) of which typical uncertainty values are given. These parameters are used in DASY4 software to improve probe accuracy close to the boundary. The sensitivity in TSL corresponds to NORM_{x,y,z} * ConvF whereby the uncertainty corresponds to that given for ConvF. A frequency dependent ConvF is used in DASY version 4.4 and higher which allows extending the validity from ± 50 MHz to ± 100 MHz.
- Spherical isotropy (3D deviation from isotropy):** in a field of low gradients realized using a flat phantom exposed by a patch antenna.
- Sensor Offset:** The sensor offset corresponds to the offset of virtual measurement center from the probe tip (on probe axis). No tolerance required.
- Connector Angle:** The angle is assessed using the information gained by determining the NORM_x (no uncertainty required).

Appendix 3-8: Calibration certificate: E-Field Probe (EX3DV4) (cont'd)

EX3DV4 – SN:3907

February 27, 2017

Probe EX3DV4

SN:3907

Manufactured: September 4, 2012
Repaired: February 15, 2017
Calibrated: February 27, 2017

Calibrated for DASY/EASY Systems
(Note: non-compatible with DASY2 system!)

Appendix 3-8: Calibration certificate: E-Field Probe (EX3DV4) (cont'd)

EX3DV4- SN:3907

February 27, 2017

DASY/EASY - Parameters of Probe: EX3DV4 - SN:3907

Basic Calibration Parameters

	Sensor X	Sensor Y	Sensor Z	Unc (k=2)
Norm ($\mu\text{V}/(\text{V}/\text{m})^2$) ^A	0.45	0.57	0.54	± 10.1 %
DGP (mV) ^B	98.9	100.0	99.0	

Modulation Calibration Parameters

UID	Communication System Name		A dB	B dB $\sqrt{\mu\text{V}}$	C	D dB	VR mV	Unc ^E (k=2)
0	CW	X	0.0	0.0	1.0	0.00	133.5	±2.7 %
		Y	0.0	0.0	1.0		150.0	
		Z	0.0	0.0	1.0		144.5	

The reported uncertainty of measurement is stated as the standard uncertainty of measurement multiplied by the coverage factor k=2, which for a normal distribution corresponds to a coverage probability of approximately 95%.

^A The uncertainties of Norm X,Y,Z do not affect the E²-field uncertainty inside TSL (see Pages 5 and 6).

^B Numerical linearization parameter: uncertainty not required.

^E Uncertainty is determined using the max. deviation from linear response applying rectangular distribution and is expressed for the square of the field value.

Appendix 3-8: Calibration certificate: E-Field Probe (EX3DV4) (cont'd)

EX3DV4– SN:3907

February 27, 2017

DASY/EASY - Parameters of Probe: EX3DV4 - SN:3907

Calibration Parameter Determined in Head Tissue Simulating Media

f (MHz) ^C	Relative Permittivity ^F	Conductivity (S/m) ^F	ConvF X	ConvF Y	ConvF Z	Alpha ^G	Depth ^G (mm)	Unc (k=2)
2450	39.2	1.80	7.37	7.37	7.37	0.35	0.82	± 12.0 %
5200	36.0	4.66	5.56	5.56	5.56	0.30	1.80	± 13.1 %
5250	35.9	4.71	5.45	5.45	5.45	0.30	1.80	± 13.1 %
5500	35.6	4.96	5.03	5.03	5.03	0.35	1.80	± 13.1 %
5600	35.5	5.07	4.69	4.69	4.69	0.40	1.80	± 13.1 %
5750	35.4	5.22	4.80	4.80	4.80	0.40	1.80	± 13.1 %
5800	35.3	5.27	4.81	4.81	4.81	0.40	1.80	± 13.1 %

^C Frequency validity above 300 MHz of ± 100 MHz only applies for DASY v4.4 and higher (see Page 2), else it is restricted to ± 50 MHz. The uncertainty is the RSS of the ConvF uncertainty at calibration frequency and the uncertainty for the indicated frequency band. Frequency validity below 300 MHz is ± 10, 25, 40, 50 and 70 MHz for ConvF assessments at 30, 64, 128, 150 and 220 MHz respectively. Above 5 GHz frequency validity can be extended to ± 110 MHz.

^F At frequencies below 3 GHz, the validity of tissue parameters (ϵ and σ) can be relaxed to ± 10% if liquid compensation formula is applied to measured SAR values. At frequencies above 3 GHz, the validity of tissue parameters (ϵ and σ) is restricted to ± 5%. The uncertainty is the RSS of the ConvF uncertainty for indicated target tissue parameters.

^G Alpha/Depth are determined during calibration. SPEAG warrants that the remaining deviation due to the boundary effect after compensation is always less than ± 1% for frequencies below 3 GHz and below ± 2% for frequencies between 3-6 GHz at any distance larger than half the probe tip diameter from the boundary.

Appendix 3-8: Calibration certificate: E-Field Probe (EX3DV4) (cont'd)

EX3DV4- SN:3907

February 27, 2017

DASY/EASY - Parameters of Probe: EX3DV4 - SN:3907

Calibration Parameter Determined in Body Tissue Simulating Media

f (MHz) ^C	Relative Permittivity ^F	Conductivity (S/m) ^F	ConvF X	ConvF Y	ConvF Z	Alpha ^G	Depth ^G (mm)	Unc (k=2)
2450	52.7	1.95	7.38	7.38	7.38	0.36	0.85	± 12.0 %
5250	48.9	5.36	4.65	4.65	4.65	0.40	1.90	± 13.1 %
5600	48.5	5.77	3.78	3.78	3.78	0.50	1.90	± 13.1 %
5750	48.3	5.94	4.13	4.13	4.13	0.50	1.90	± 13.1 %

^C Frequency validity above 300 MHz of ± 100 MHz only applies for DASY v4.4 and higher (see Page 2), else it is restricted to ± 50 MHz. The uncertainty is the RSS of the ConvF uncertainty at calibration frequency and the uncertainty for the indicated frequency band. Frequency validity below 300 MHz is ± 10, 25, 40, 50 and 70 MHz for ConvF assessments at 30, 64, 128, 150 and 220 MHz respectively. Above 5 GHz frequency validity can be extended to ± 110 MHz.

^F At frequencies below 3 GHz, the validity of tissue parameters (ϵ and σ) can be relaxed to ± 10% if liquid compensation formula is applied to measured SAR values. At frequencies above 3 GHz, the validity of tissue parameters (ϵ and σ) is restricted to ± 5%. The uncertainty is the RSS of the ConvF uncertainty for indicated target tissue parameters.

^G Alpha/Depth are determined during calibration. SPEAG warrants that the remaining deviation due to the boundary effect after compensation is always less than ± 1% for frequencies below 3 GHz and below ± 2% for frequencies between 3-6 GHz at any distance larger than half the probe tip diameter from the boundary.

Appendix 3-8: Calibration certificate: E-Field Probe (EX3DV4) (cont'd)

EX3DV4- SN:3907

February 27, 2017

Frequency Response of E-Field
(TEM-Cell:ifi110 EXX, Waveguide: R22)

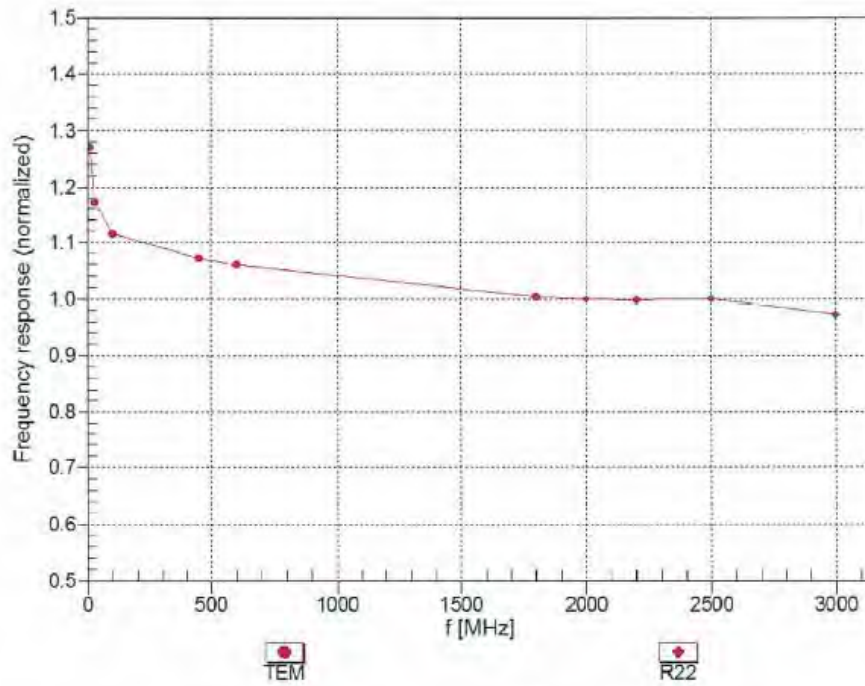

Uncertainty of Frequency Response of E-field: $\pm 6.3\%$ (k=2)

Appendix 3-8: Calibration certificate: E-Field Probe (EX3DV4) (cont'd)

EX3DV4- SN:3907

February 27, 2017

Receiving Pattern (ϕ), $\theta = 0^\circ$

f=600 MHz, TEM

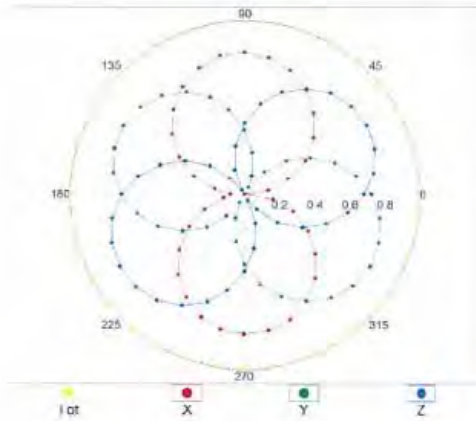

f=1800 MHz, R22

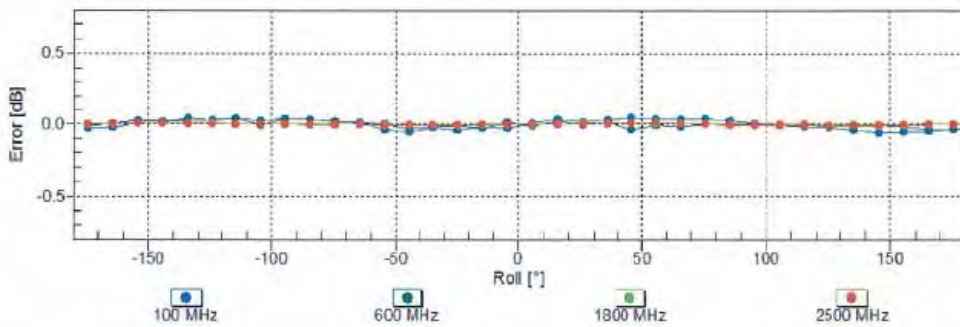
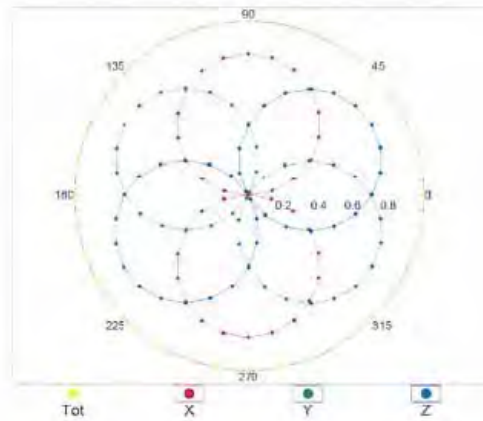

Uncertainty of Axial Isotropy Assessment: $\pm 0.5\%$ (k=2)

Appendix 3-8: Calibration certificate: E-Field Probe (EX3DV4) (cont'd)

EX3DV4- SN:3907

February 27, 2017

Dynamic Range f(SAR_{head})
 (TEM cell, f_{eval}= 1900 MHz)

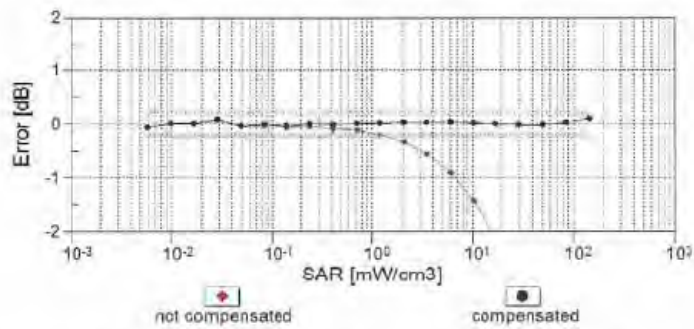
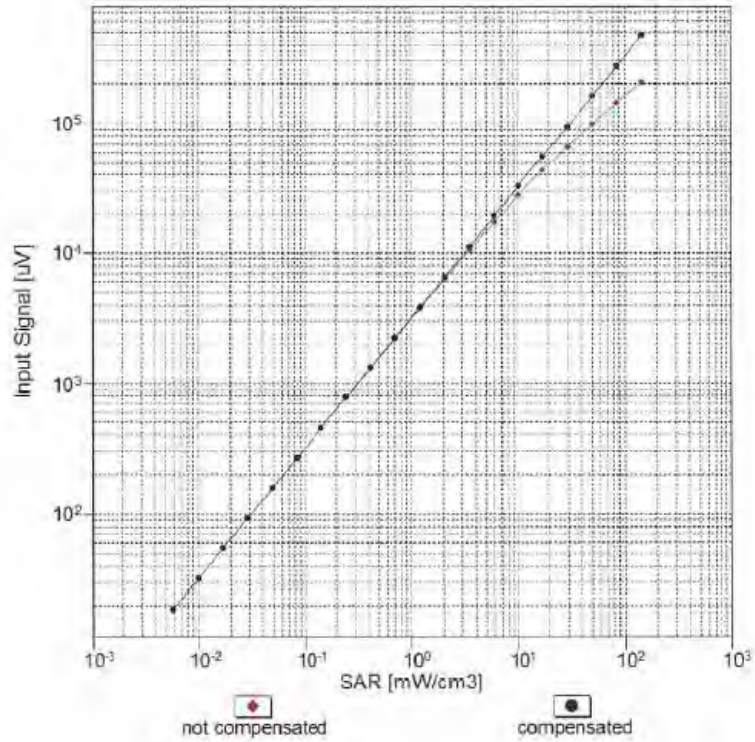

Uncertainty of Linearity Assessment: ± 0.6% (k=2)

Appendix 3-8: Calibration certificate: E-Field Probe (EX3DV4) (cont'd)

EX3DV4- SN:3907

February 27, 2017

Conversion Factor Assessment

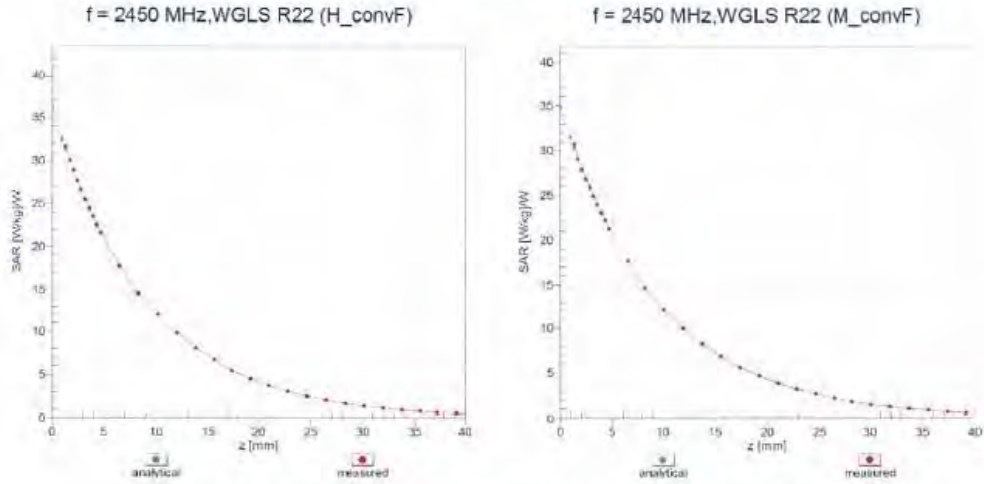

Deviation from Isotropy in Liquid Error (ϕ , θ), f = 900 MHz

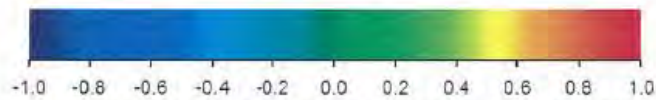
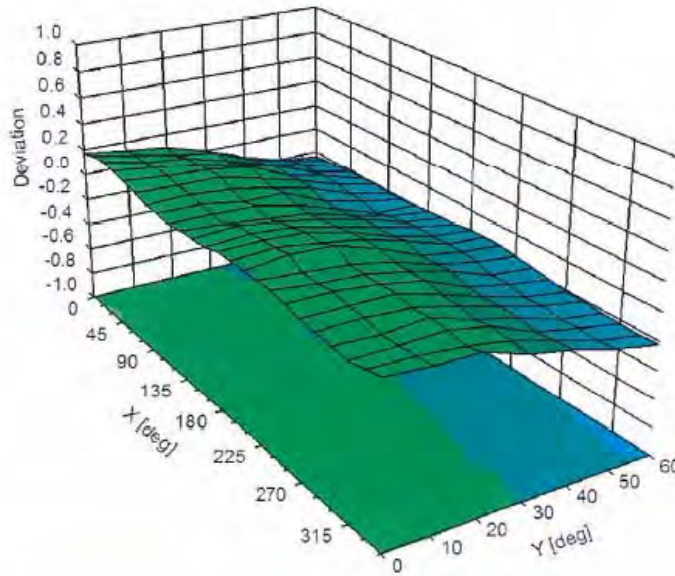

Uncertainty of Spherical Isotropy Assessment: $\pm 2.6\%$ (k=2)

Appendix 3-8: Calibration certificate: E-Field Probe (EX3DV4) (cont'd)

EX3DV4- SN:3907

February 27, 2017

DASY/EASY - Parameters of Probe: EX3DV4 - SN:3907

Other Probe Parameters

Sensor Arrangement	Triangular
Connector Angle (°)	45.6
Mechanical Surface Detection Mode	enabled
Optical Surface Detection Mode	disabled
Probe Overall Length	337 mm
Probe Body Diameter	10 mm
Tip Length	9 mm
Tip Diameter	2.5 mm
Probe Tip to Sensor X Calibration Point	1 mm
Probe Tip to Sensor Y Calibration Point	1 mm
Probe Tip to Sensor Z Calibration Point	1 mm
Recommended Measurement Distance from Surface	1.4 mm

Appendix 3-9: Calibration certificate: Dipole (D2450V2)

**Calibration Laboratory of
 Schmid & Partner
 Engineering AG**
 Zeughausstrasse 43, 8004 Zurich, Switzerland



S Schweizerischer Kalibrierdienst
C Service suisse d'étalonnage
S Servizio svizzero di taratura
S Swiss Calibration Service

Accredited by the Swiss Accreditation Service (SAS)
 The Swiss Accreditation Service is one of the signatories to the EA
 Multilateral Agreement for the recognition of calibration certificates

Accreditation No.: **SCS 0108**

Client **UL Japan Shonan (Vitec)**

Certificate No: **D2450V2-822_Jan17**

CALIBRATION CERTIFICATE

Object **D2450V2 - SN:822**

Calibration procedure(s) **QA CAL-05.v9**
 Calibration procedure for dipole validation kits above 700 MHz

Calibration date: **January 11, 2017**

This calibration certificate documents the traceability to national standards, which realize the physical units of measurements (SI).
 The measurements and the uncertainties with confidence probability are given on the following pages and are part of the certificate.

All calibrations have been conducted in the closed laboratory facility: environment temperature (22 ± 3)°C and humidity < 70%.

Calibration Equipment used (M&TE critical for calibration)

Primary Standards	ID #	Cal Date (Certificate No.)	Scheduled Calibration
Power meter NRP	SN: 104778	06-Apr-16 (No. 217-02288/02289)	Apr-17
Power sensor NRP-Z91	SN: 103244	06-Apr-16 (No. 217-02288)	Apr-17
Power sensor NRP-Z91	SN: 103245	06-Apr-16 (No. 217-02289)	Apr-17
Reference 20 dB Attenuator	SN: 5058 (20k)	05-Apr-16 (No. 217-02292)	Apr-17
Type-N mismatch combination	SN: 5047.2 / 06327	05-Apr-16 (No. 217-02295)	Apr-17
Reference Probe EX3DV4	SN: 7349	31-Dec-16 (No. EX3-7349_Dec16)	Dec-17
DAE4	SN: 601	04-Jan-17 (No. DAE4-601_Jan17)	Jan-18
Secondary Standards	ID #	Check Date (in house)	Scheduled Check
Power meter EPM-442A	SN: GB37480704	07-Oct-15 (in house check Oct-16)	In house check: Oct-18
Power sensor HP 8481A	SN: US37292783	07-Oct-15 (in house check Oct-16)	In house check: Oct-18
Power sensor HP 8481A	SN: MY4-1092317	07-Oct-15 (in house check Oct-16)	In house check: Oct-18
RF generator R&S SMT-06	SN: 100972	15-Jun-15 (in house check Oct-16)	In house check: Oct-18
Network Analyzer HP 8753E	SN: US37390585	18-Oct-01 (in house check Oct-16)	In house check: Oct-17

	Name	Function	Signature
Calibrated by:	Jeton Kastrati	Laboratory Technician	
Approved by:	Katja Pokovic	Technical Manager	

Issued: January 13, 2017

This calibration certificate shall not be reproduced except in full without written approval of the laboratory.

Appendix 3-9: Calibration certificate: Dipole (D2450V2) (cont'd)

**Calibration Laboratory of
Schmid & Partner
Engineering AG**
Zeughausstrasse 43, 8004 Zurich, Switzerland



S Schweizerischer Kalibrierdienst
S Service suisse d'étalonnage
C Servizio svizzero di taratura
S Swiss Calibration Service

Accredited by the Swiss Accreditation Service (SAS)
The Swiss Accreditation Service is one of the signatories to the EA
Multilateral Agreement for the recognition of calibration certificates

Accreditation No.: **SCS 0108**

Glossary:

TSL tissue simulating liquid
ConvF sensitivity in TSL / NORM x,y,z
N/A not applicable or not measured

Calibration is Performed According to the Following Standards:

- a) IEEE Std 1528-2013, "IEEE Recommended Practice for Determining the Peak Spatial-Averaged Specific Absorption Rate (SAR) in the Human Head from Wireless Communications Devices: Measurement Techniques", June 2013
- b) IEC 62209-1, "Procedure to measure the Specific Absorption Rate (SAR) for hand-held devices used in close proximity to the ear (frequency range of 300 MHz to 3 GHz)", February 2005
- c) IEC 62209-2, "Procedure to determine the Specific Absorption Rate (SAR) for wireless communication devices used in close proximity to the human body (frequency range of 30 MHz to 6 GHz)", March 2010
- d) KDB 865664, "SAR Measurement Requirements for 100 MHz to 6 GHz"

Additional Documentation:

- e) DASY4/5 System Handbook

Methods Applied and Interpretation of Parameters:

- *Measurement Conditions:* Further details are available from the Validation Report at the end of the certificate. All figures stated in the certificate are valid at the frequency indicated.
- *Antenna Parameters with TSL:* The dipole is mounted with the spacer to position its feed point exactly below the center marking of the flat phantom section, with the arms oriented parallel to the body axis.
- *Feed Point Impedance and Return Loss:* These parameters are measured with the dipole positioned under the liquid filled phantom. The impedance stated is transformed from the measurement at the SMA connector to the feed point. The Return Loss ensures low reflected power. No uncertainty required.
- *Electrical Delay:* One-way delay between the SMA connector and the antenna feed point. No uncertainty required.
- *SAR measured:* SAR measured at the stated antenna input power.
- *SAR normalized:* SAR as measured, normalized to an input power of 1 W at the antenna connector.
- *SAR for nominal TSL parameters:* The measured TSL parameters are used to calculate the nominal SAR result.

The reported uncertainty of measurement is stated as the standard uncertainty of measurement multiplied by the coverage factor $k=2$, which for a normal distribution corresponds to a coverage probability of approximately 95%.

Appendix 3-9: Calibration certificate: Dipole (D2450V2) (cont'd)

Measurement Conditions

DASY system configuration, as far as not given on page 1.

DASY Version	DASY5	V52.8.8
Extrapolation	Advanced Extrapolation	
Phantom	Modular Flat Phantom	
Distance Dipole Center - TSL	10 mm	with Spacer
Zoom Scan Resolution	dx, dy, dz = 5 mm	
Frequency	2450 MHz ± 1 MHz	

Head TSL parameters

The following parameters and calculations were applied.

	Temperature	Permittivity	Conductivity
Nominal Head TSL parameters	22.0 °C	39.2	1.80 mho/m
Measured Head TSL parameters	(22.0 ± 0.2) °C	38.0 ± 6 %	1.88 mho/m ± 6 %
Head TSL temperature change during test	< 0.5 °C	----	----

SAR result with Head TSL

SAR averaged over 1 cm³ (1 g) of Head TSL	Condition	
SAR measured	250 mW input power	13.1 W/kg
SAR for nominal Head TSL parameters	normalized to 1W	51.0 W/kg ± 17.0 % (k=2)

SAR averaged over 10 cm³ (10 g) of Head TSL	condition	
SAR measured	250 mW input power	6.09 W/kg
SAR for nominal Head TSL parameters	normalized to 1W	24.0 W/kg ± 16.5 % (k=2)

Body TSL parameters

The following parameters and calculations were applied.

	Temperature	Permittivity	Conductivity
Nominal Body TSL parameters	22.0 °C	52.7	1.95 mho/m
Measured Body TSL parameters	(22.0 ± 0.2) °C	52.7 ± 6 %	2.02 mho/m ± 6 %
Body TSL temperature change during test	< 0.5 °C	----	----

SAR result with Body TSL

SAR averaged over 1 cm³ (1 g) of Body TSL	Condition	
SAR measured	250 mW input power	12.6 W/kg
SAR for nominal Body TSL parameters	normalized to 1W	49.6 W/kg ± 17.0 % (k=2)

SAR averaged over 10 cm³ (10 g) of Body TSL	condition	
SAR measured	250 mW input power	5.88 W/kg
SAR for nominal Body TSL parameters	normalized to 1W	23.3 W/kg ± 16.5 % (k=2)

Appendix 3-9: Calibration certificate: Dipole (D2450V2) (cont'd)

Appendix (Additional assessments outside the scope of SCS 0108)

Antenna Parameters with Head TSL

Impedance, transformed to feed point	55.4 Ω + 5.1 j Ω
Return Loss	- 23.0 dB

Antenna Parameters with Body TSL

Impedance, transformed to feed point	50.6 Ω + 5.9 j Ω
Return Loss	- 24.5 dB

General Antenna Parameters and Design

Electrical Delay (one direction)	1.158 ns
----------------------------------	----------

After long term use with 100W radiated power, only a slight warming of the dipole near the feedpoint can be measured.

The dipole is made of standard semirigid coaxial cable. The center conductor of the feeding line is directly connected to the second arm of the dipole. The antenna is therefore short-circuited for DC-signals. On some of the dipoles, small end caps are added to the dipole arms in order to improve matching when loaded according to the position as explained in the "Measurement Conditions" paragraph. The SAR data are not affected by this change. The overall dipole length is still according to the Standard.

No excessive force must be applied to the dipole arms, because they might bend or the soldered connections near the feedpoint may be damaged.

Additional EUT Data

Manufactured by	SPEAG
Manufactured on	December 11, 2008

Appendix 3-9: Calibration certificate: Dipole (D2450V2) (cont'd)

DASY5 Validation Report for Head TSL

Date: 10.01.2017

Test Laboratory: SPEAG, Zurich, Switzerland

DUT: Dipole 2450 MHz; Type: D2450V2; Serial: D2450V2 - SN:822

Communication System: UID 0 - CW; Frequency: 2450 MHz

Medium parameters used: $f = 2450$ MHz; $\sigma = 1.88$ S/m; $\epsilon_r = 38$; $\rho = 1000$ kg/m³

Phantom section: Flat Section

Measurement Standard: DASY5 (IEEE/IEC/ANSI C63.19-2011)

DASY52 Configuration:

- Probe: EX3DV4 - SN7349; ConvF(7.72, 7.72, 7.72); Calibrated: 31.12.2016;
- Sensor-Surface: 1.4mm (Mechanical Surface Detection)
- Electronics: DAE4 Sn601; Calibrated: 04.01.2017
- Phantom: Flat Phantom 5.0 (front); Type: QD 000 P50 AA; Serial: 1001
- DASY52 52.8.8(1258); SEMCAD X 14.6.10(7372)

Dipole Calibration for Head Tissue/Pin=250 mW, d=10mm/Zoom Scan (7x7x7)/Cube 0:

Measurement grid: dx=5mm, dy=5mm, dz=5mm

Reference Value = 112.9 V/m; Power Drift = -0.06 dB

Peak SAR (extrapolated) = 26.9 W/kg

SAR(1 g) = 13.1 W/kg; SAR(10 g) = 6.09 W/kg

Maximum value of SAR (measured) = 21.6 W/kg

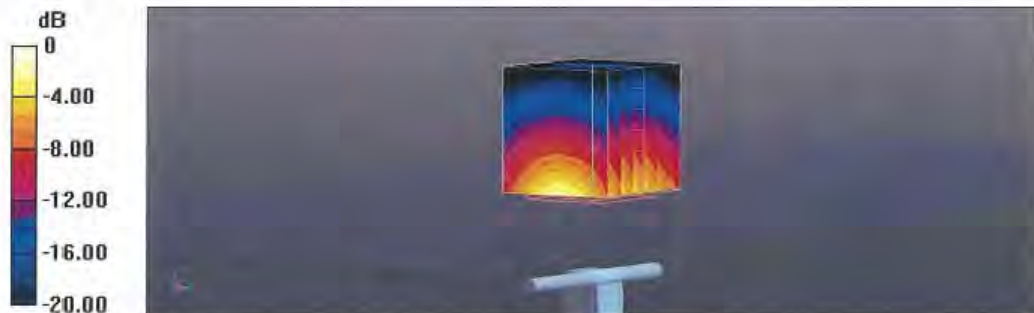

Appendix 3-9: Calibration certificate: Dipole (D2450V2) (cont'd)

Impedance Measurement Plot for Head TSL

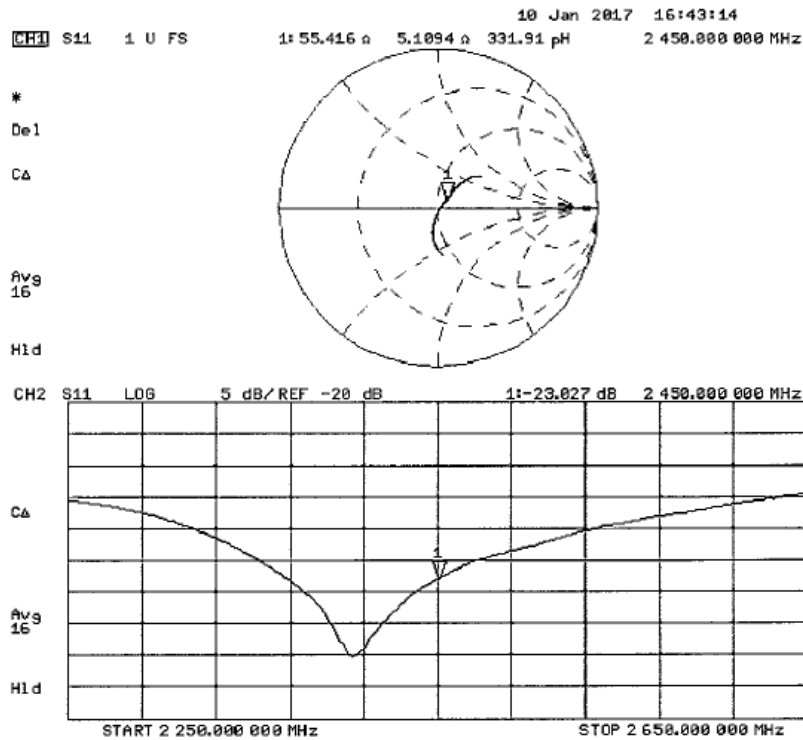

Appendix 3-9: Calibration certificate: Dipole (D2450V2) (cont'd)

DASY5 Validation Report for Body TSL

Date: 11.01.2017

Test Laboratory: SPEAG, Zurich, Switzerland

DUT: Dipole 2450 MHz; Type: D2450V2; Serial: D2450V2 - SN:822

Communication System: UID 0 - CW; Frequency: 2450 MHz

Medium parameters used: $f = 2450$ MHz; $\sigma = 2.02$ S/m; $\epsilon_r = 52.7$; $\rho = 1000$ kg/m³

Phantom section: Flat Section

Measurement Standard: DASY5 (IEEE/IEC/ANSI C63.19-2011)

DASY52 Configuration:

- Probe: EX3DV4 - SN7349; ConvF(7.79, 7.79, 7.79); Calibrated: 31.12.2016;
- Sensor-Surface: 1.4mm (Mechanical Surface Detection)
- Electronics: DAE4 Sn601; Calibrated: 04.01.2017
- Phantom: Flat Phantom 5.0 (back); Type: QD 000 P50 AA; Serial: 1002
- DASY52 52.8.8(1258); SEMCAD X 14.6.10(7372)

Dipole Calibration for Body Tissue/Pin=250 mW, d=10mm/Zoom Scan (7x7x7)/Cube 0:

Measurement grid: dx=5mm, dy=5mm, dz=5mm

Reference Value = 104.9 V/m; Power Drift = -0.08 dB

Peak SAR (extrapolated) = 25.5 W/kg

SAR(1 g) = 12.6 W/kg; SAR(10 g) = 5.88 W/kg

Maximum value of SAR (measured) = 20.1 W/kg

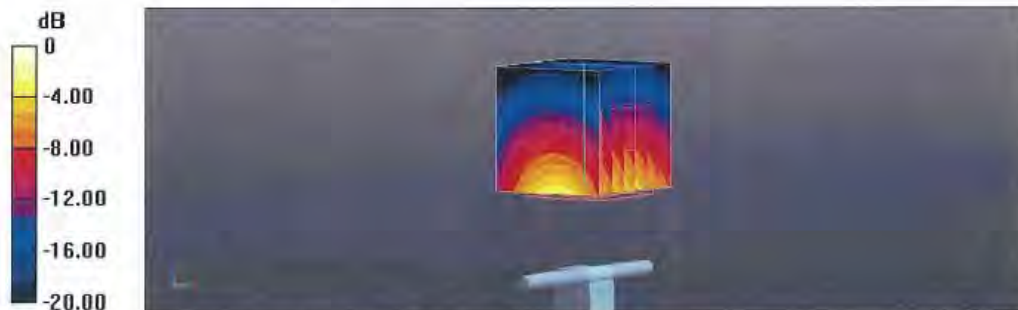

Appendix 3-9: Calibration certificate: Dipole (D2450V2) (cont'd)

Impedance Measurement Plot for Body TSL

