



Lynx WiFi Mesh Antenna Data Sheet

Date : Aug. 22, 2022
Prepared by : Jerry Ko



Outline

- Test Information
- Test Configuration
- Test Setup & Procedure
- Test Equipment & Calibration
- Antenna Specification
- Antenna Structure & Placement
- Return Loss & Isolation
- 3D / 2D Radiation Pattern
- Peak Gain & Efficiency

Test Information

Item	Description
Brand Name	Sony
Equipment	Wi-Fi Mesh
Test Location	8F, No. 3-1, YuanQu St. Taipei, Taiwan 115 R.O.C.
Test Condition	Radiation
Test Engineer	Jerry Ko
Test Environment	ETS-8500 Antenna Measurement Chamber
Test Date	Aug. 20, 2022 ~ Aug. 25, 2022

Test Configuration

ETS AMS-8500 antenna measurement system with a size of 7.32(L) × 3.66(W) × 3.66(H) m³ is used for antenna performance test, which is based on the great-circle test method defined by CTIA. The multi-axis positioning system (MAPS) rotates the DUT around two orthogonal axes for full spherical coverage.

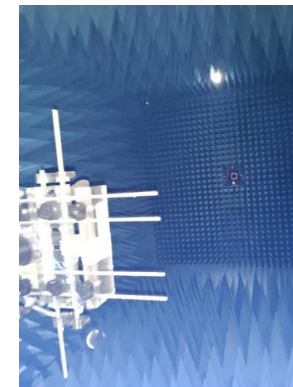
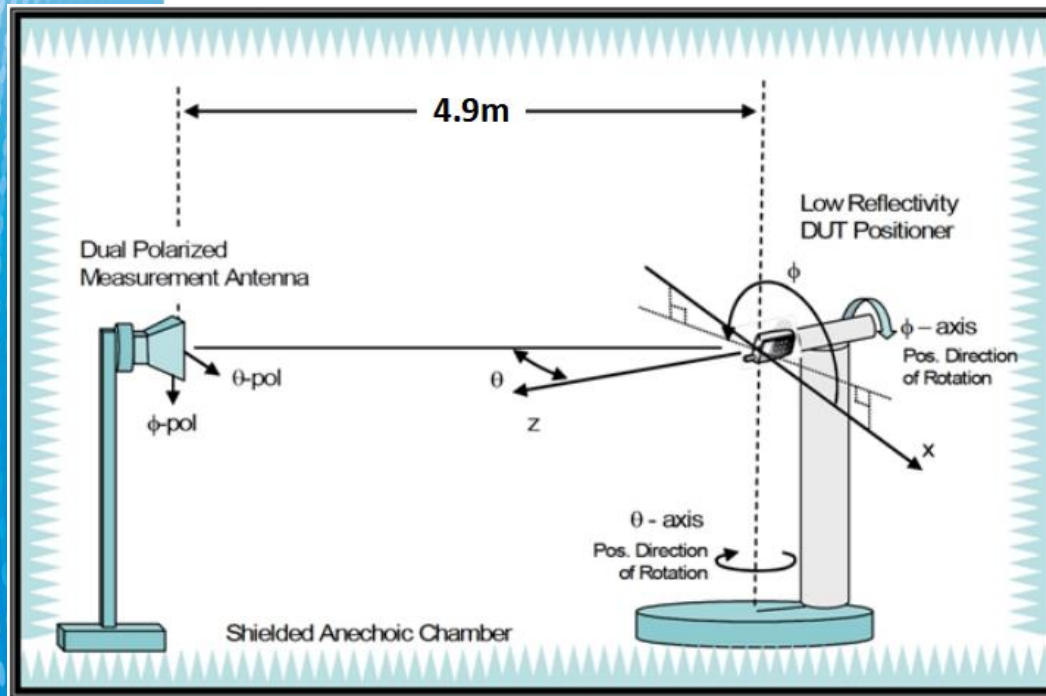

Test Setup & Procedure

1. Fix the DUT on the dielectric support structure and connect the feeding cable to the antenna used for test
2. Set measurement parameters such as frequency range and sampling angle
3. Perform 3D test and then get far-field data (radiation pattern, gain, efficiency)

Test Equipment & Calibration

Network analyzer and reference antennas (Precision Sleeve Dipole) are used for calibration. Path loss for each band can be checked and calculated.

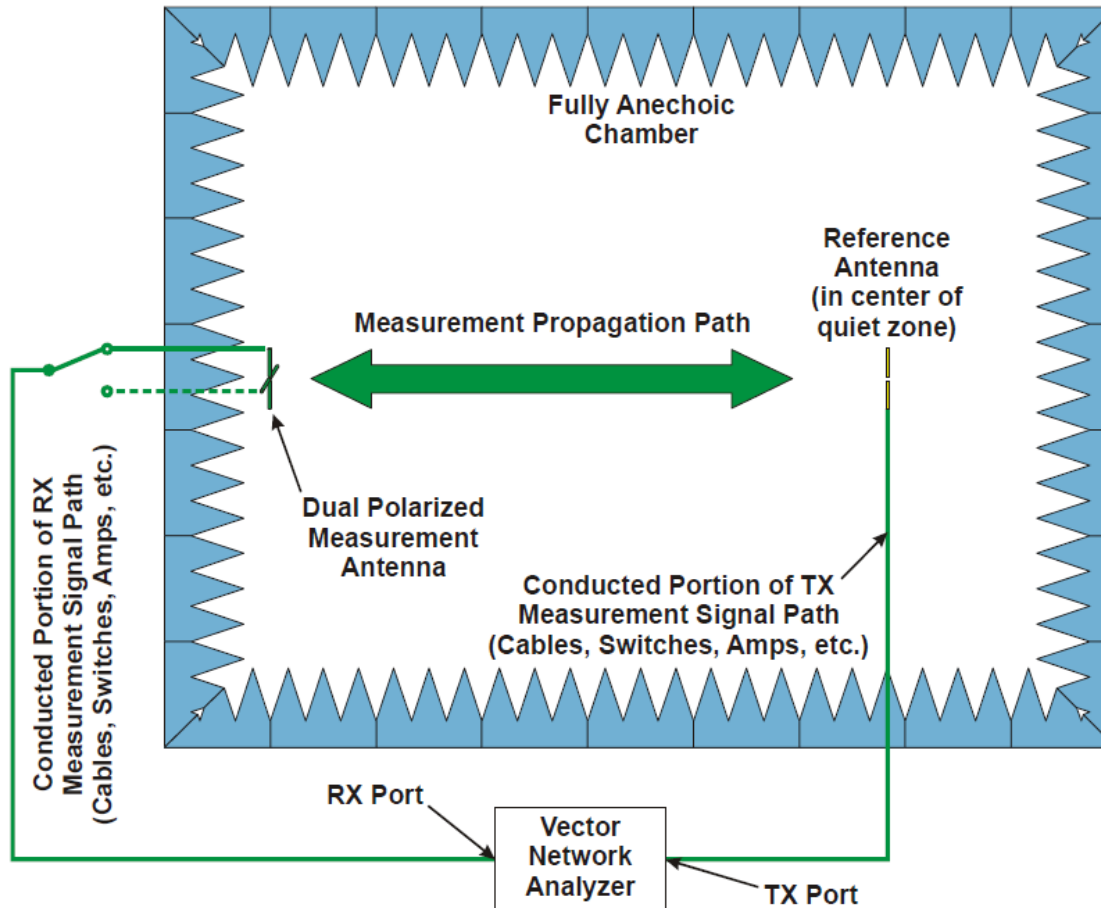

Antenna Specification

Feature	WiFi 2G	WiFi 5G
Quantity	2	2
Return Loss	> 10dB	> 10dB
Isolation	> 20dB	> 20dB
Efficiency	> 50%	> 50%
Peak Gain	< 3dBi	< 3dBi

Antenna Structure & Placement

Ant No.	Operating Band	Type	Material	Feeding	Dimension
Ant 1	WiFi 2.4G	PIFA	Metal	RF trace	30.5 x 3 x 10.2 mm ³
Ant 2	WiFi 2.4G	PIFA	Metal	RF trace	30.5 x 3 x 10.2 mm ³
Ant 3	WiFi 5G	PIFA	Metal	RF trace	21.5 x 0.5 x 12 mm ³
Ant 4	WiFi 5G	PIFA	Metal	RF trace	21.5 x 0.5 x 12 mm ³

Return Loss – Ant 1

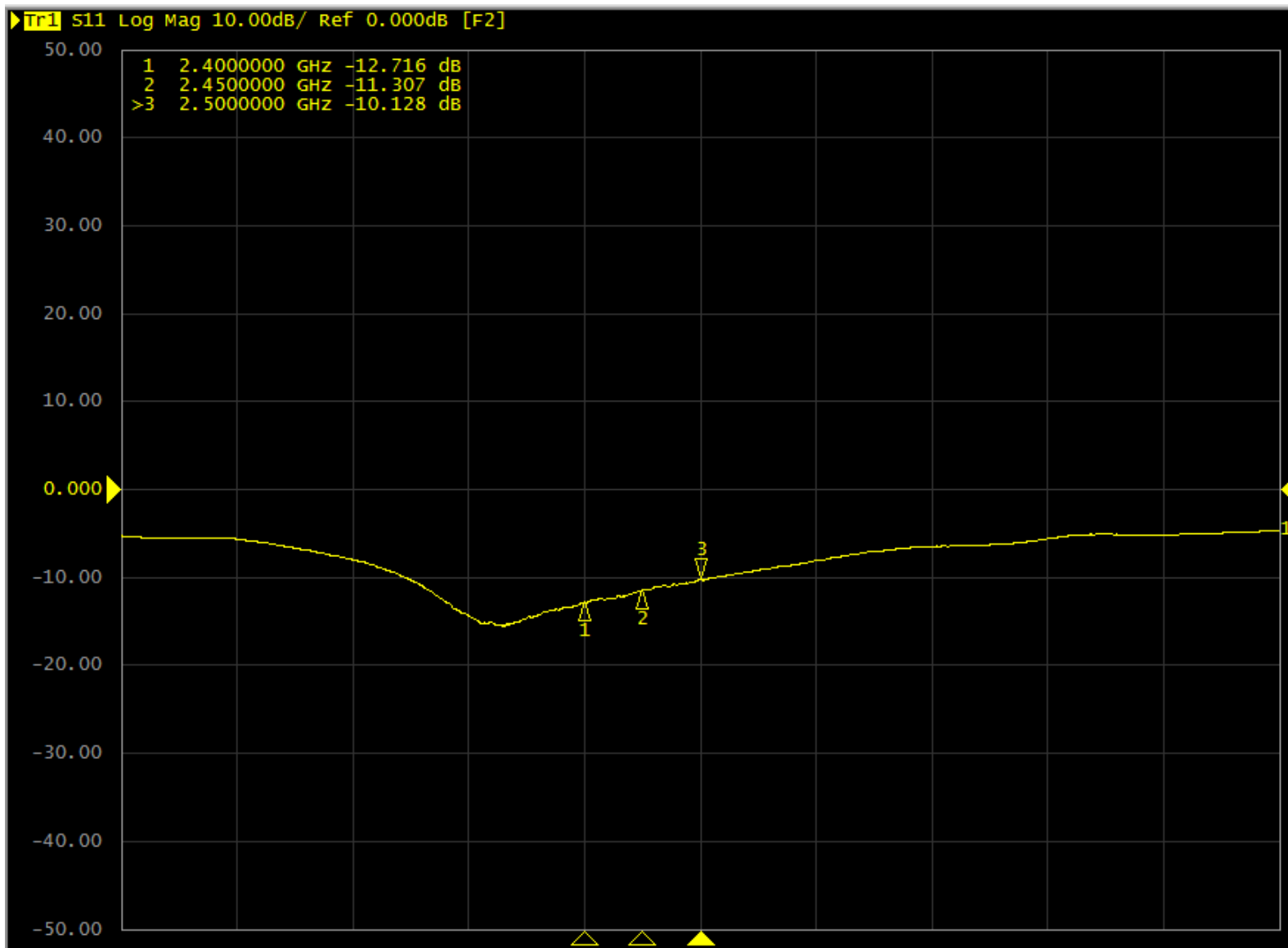

Return Loss – Ant 2

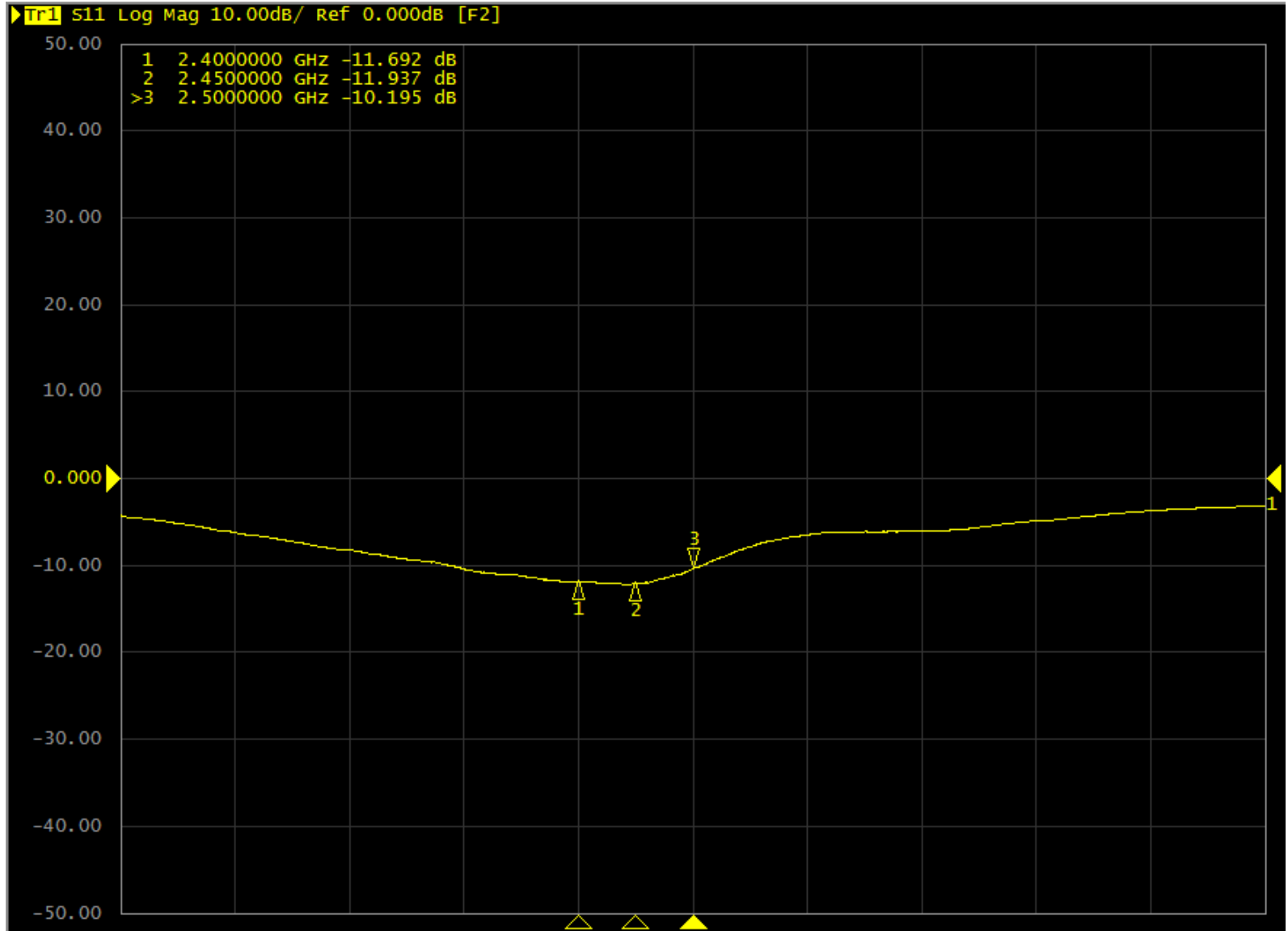

Return Loss – Ant 3

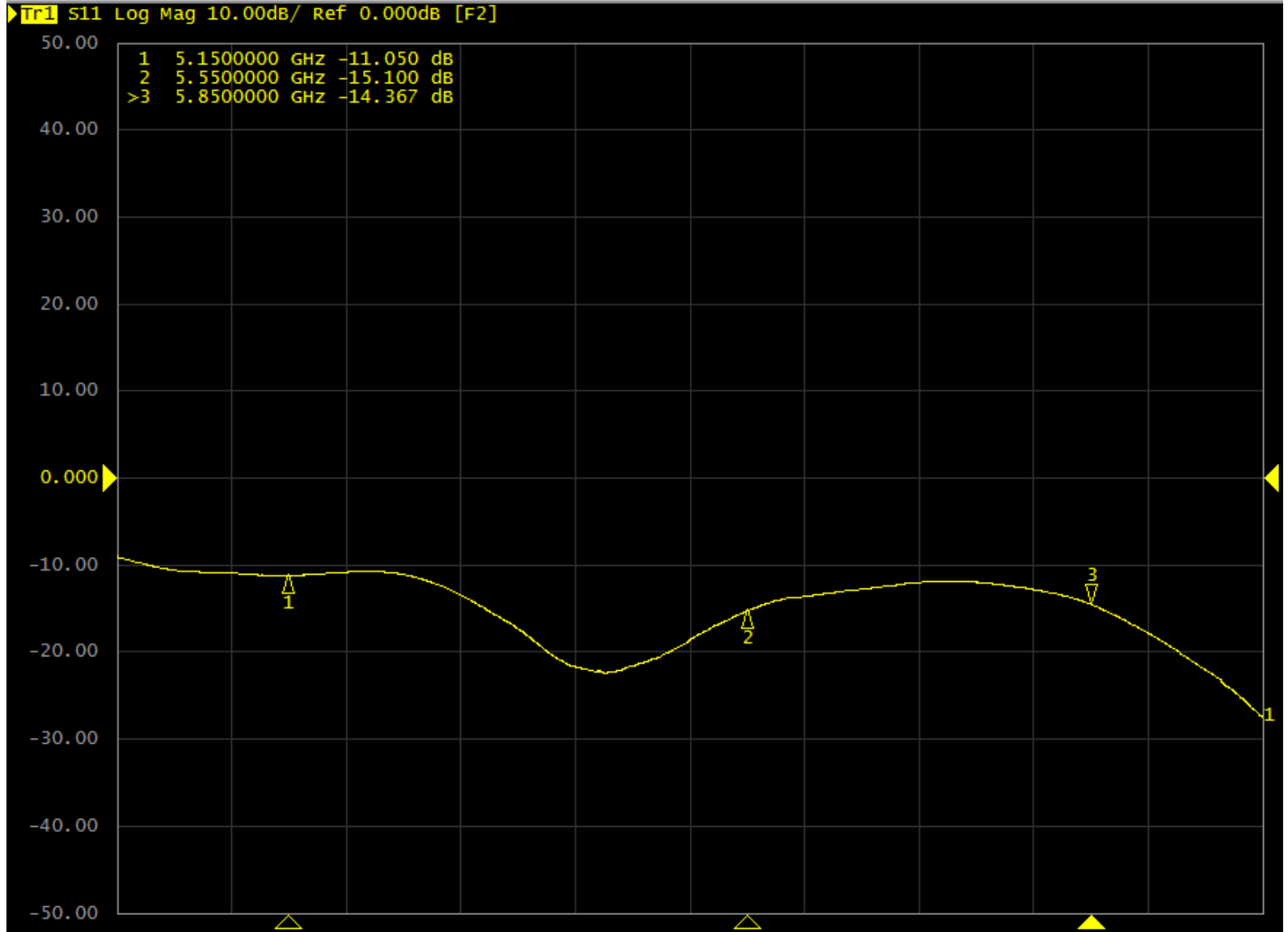

Return Loss – Ant 4

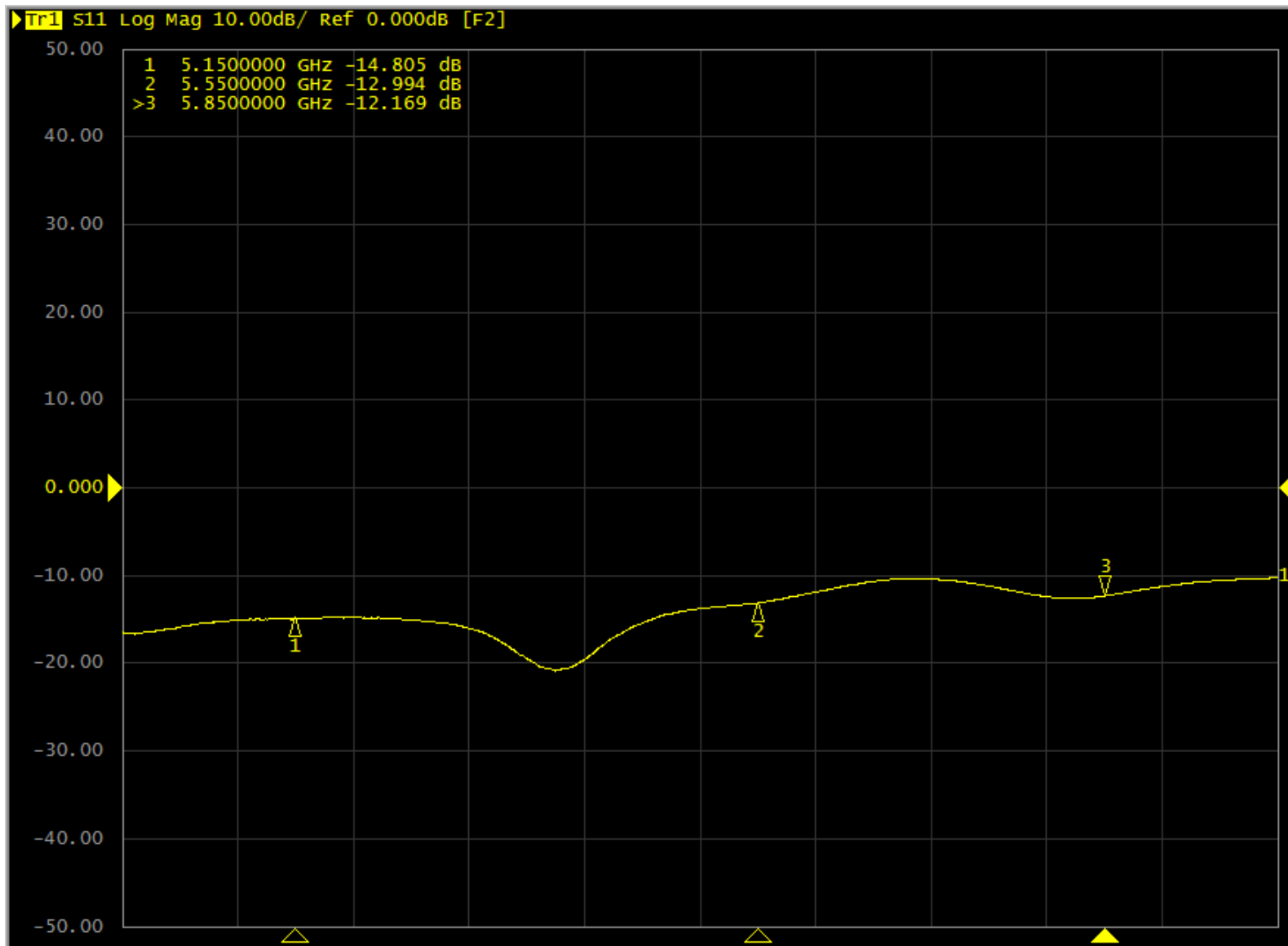

Isolation – Ant 1 & Ant 2

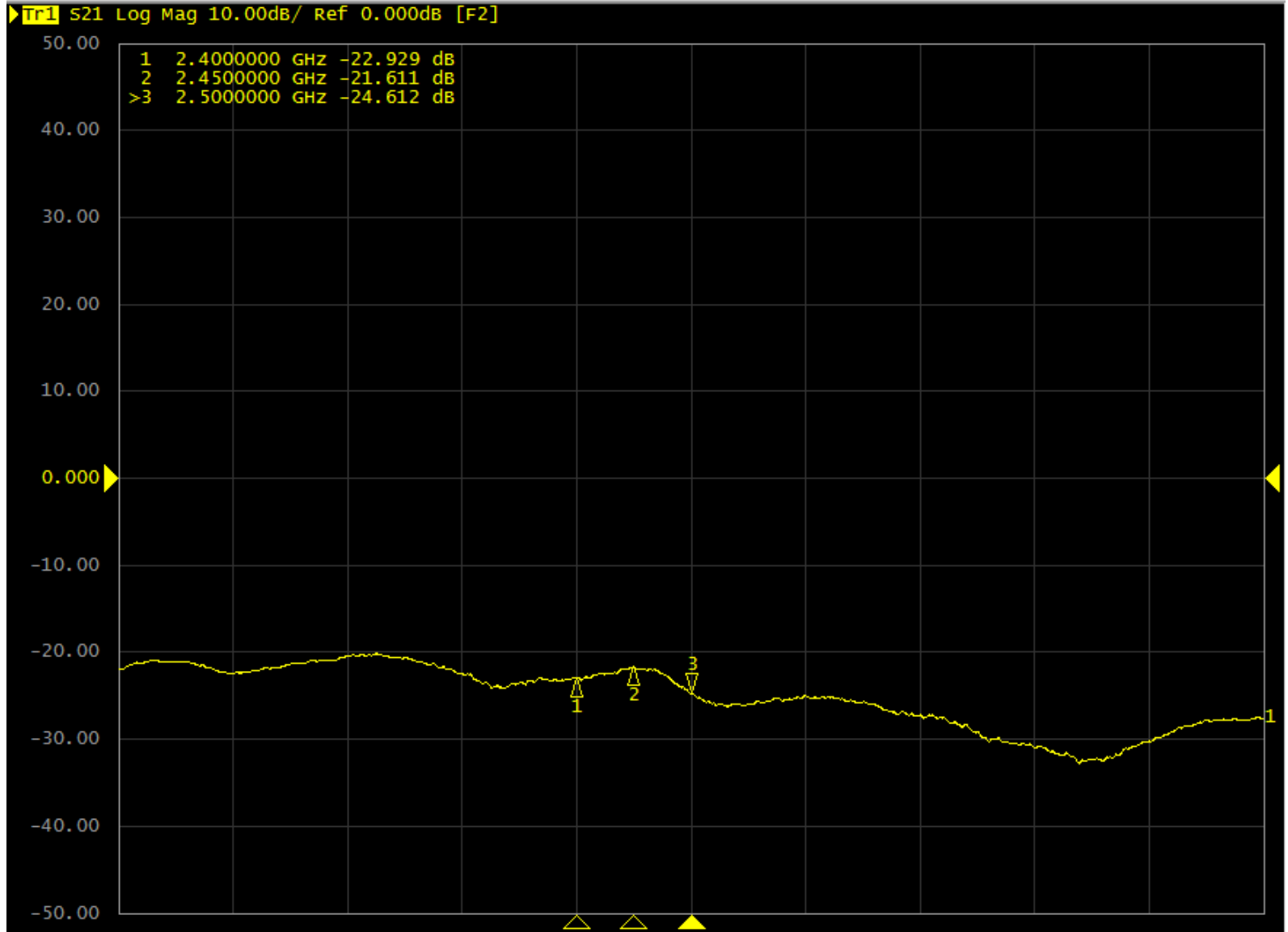

Isolation – Ant 3 & Ant 4

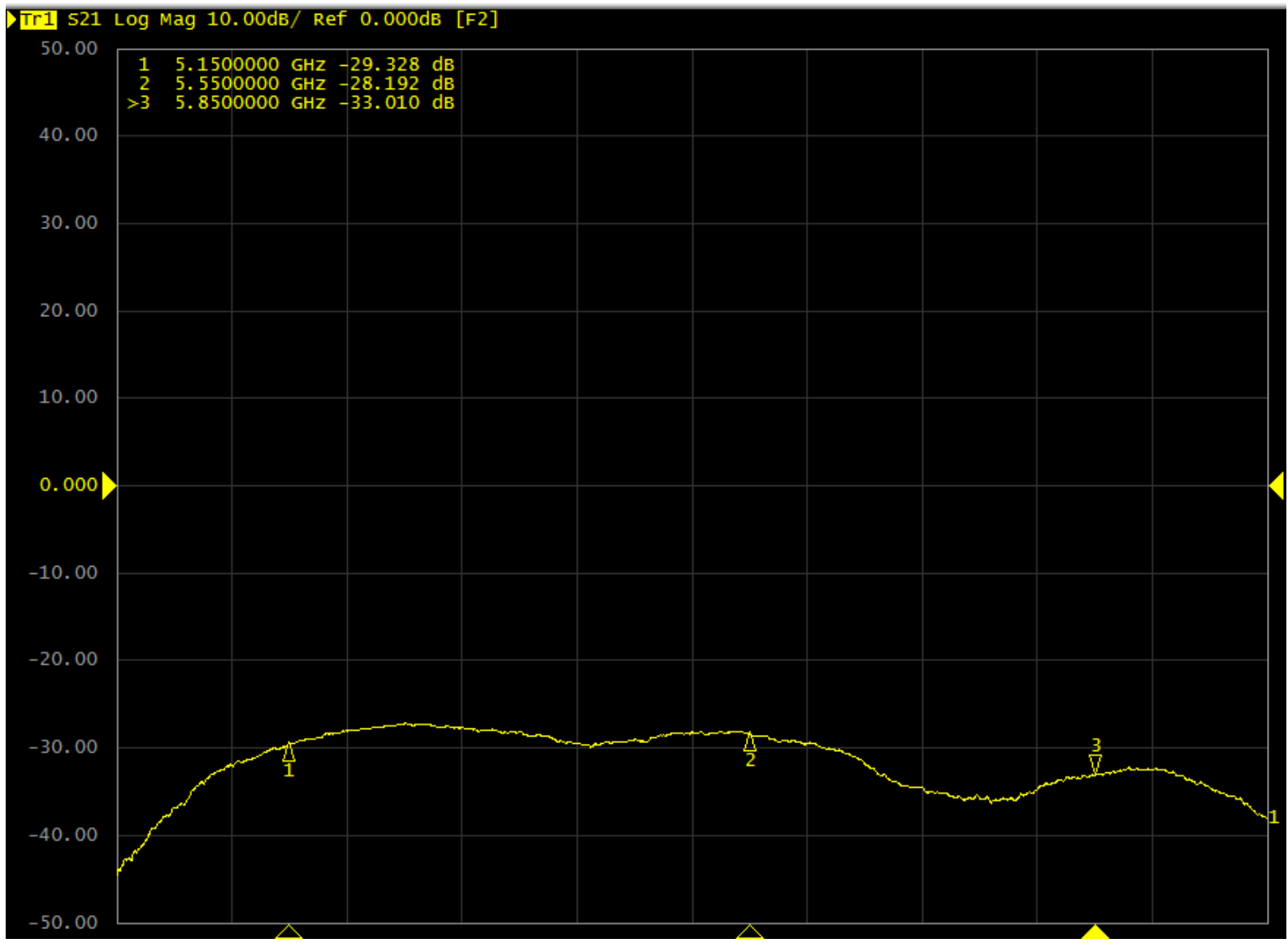

Antenna Measurement Chamber

- ETS AMS-8500 antenna measurement system
- Interior dimensions : 7.32(L)×3.66(W)×3.66(H)m³
- Operating band : 700 MHz – 10 GHz
- Support passive test & active test
- Provide graphic data display

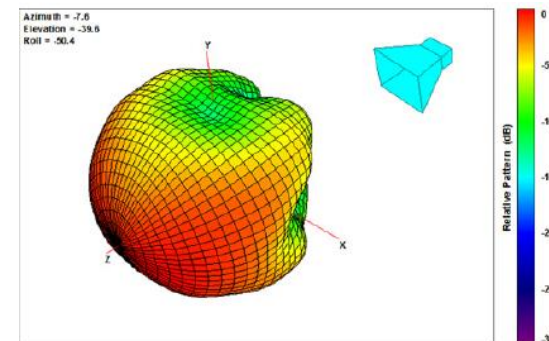
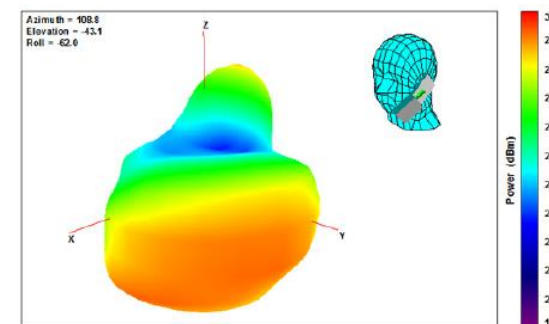
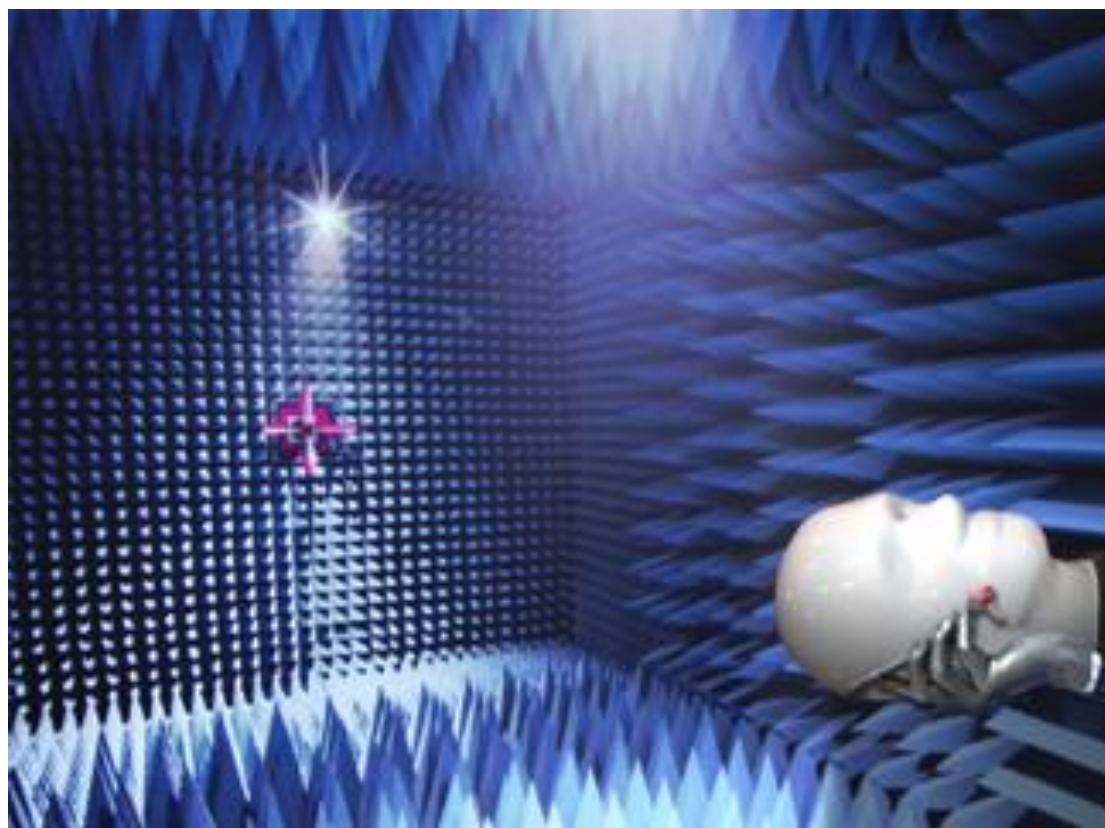

3D Radiation Pattern – Ant 1

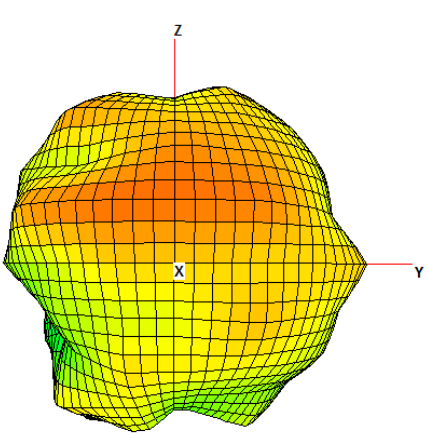
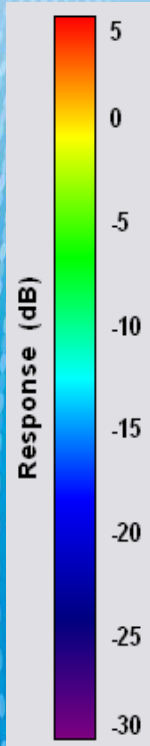

YZ-Plane

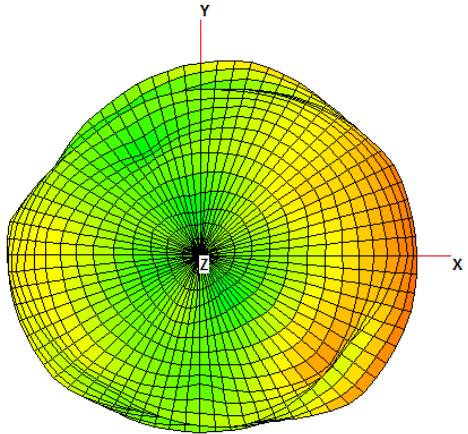
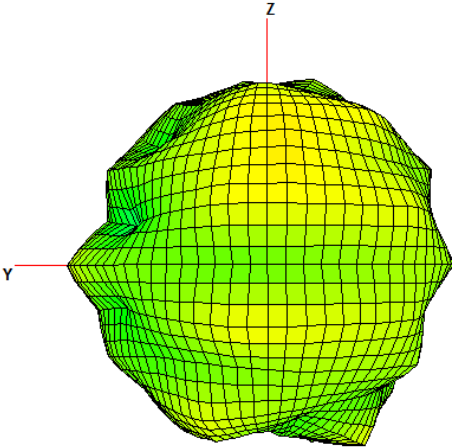

XY-Plane

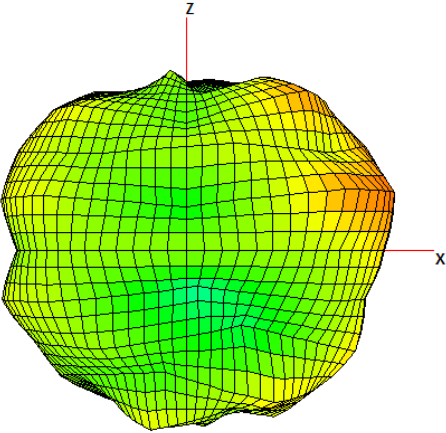

XZ-Plane

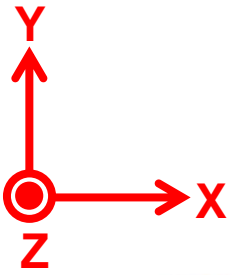
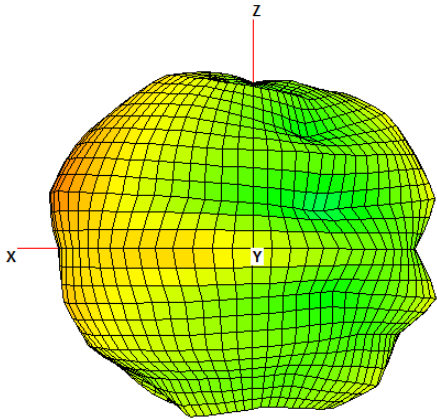

3D Radiation Pattern – Ant 2

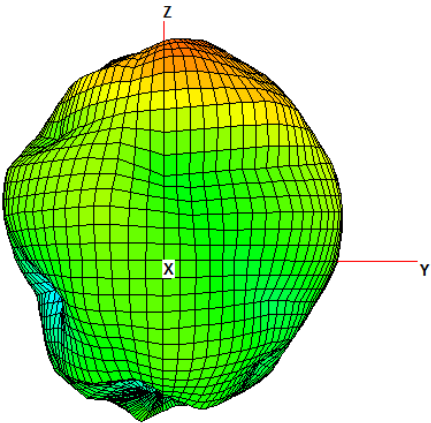
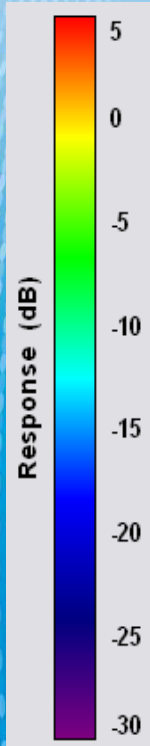

YZ-Plane

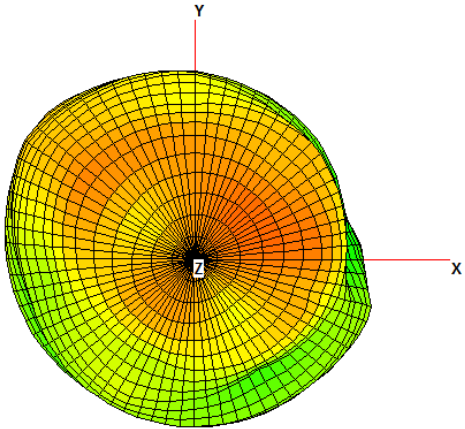
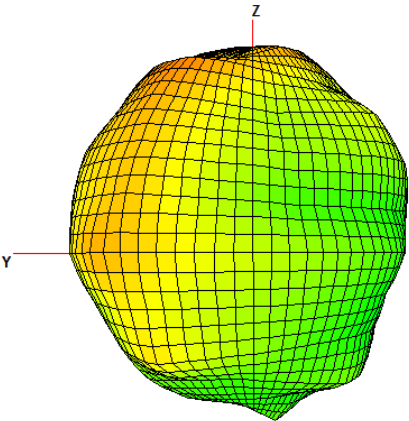

XY-Plane

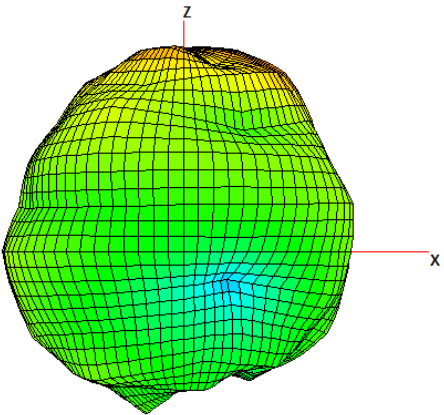

XZ-Plane

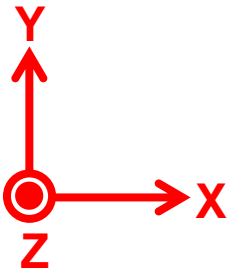
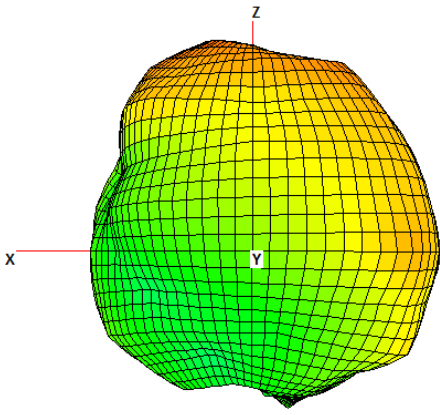

3D Radiation Pattern – Ant 3

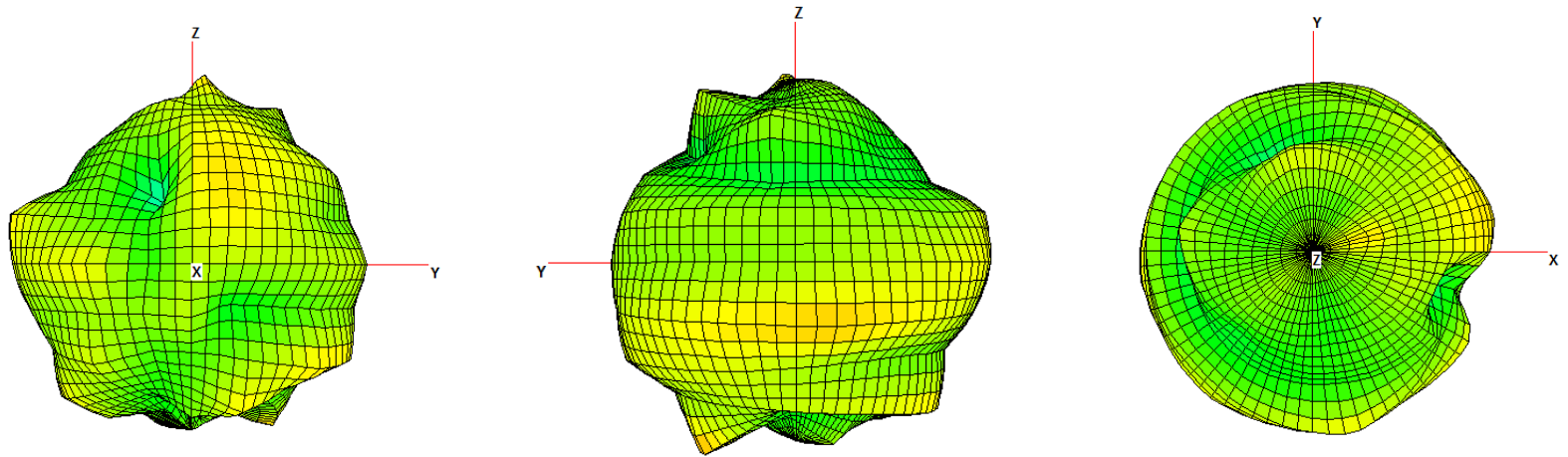

YZ-Plane

XY-Plane

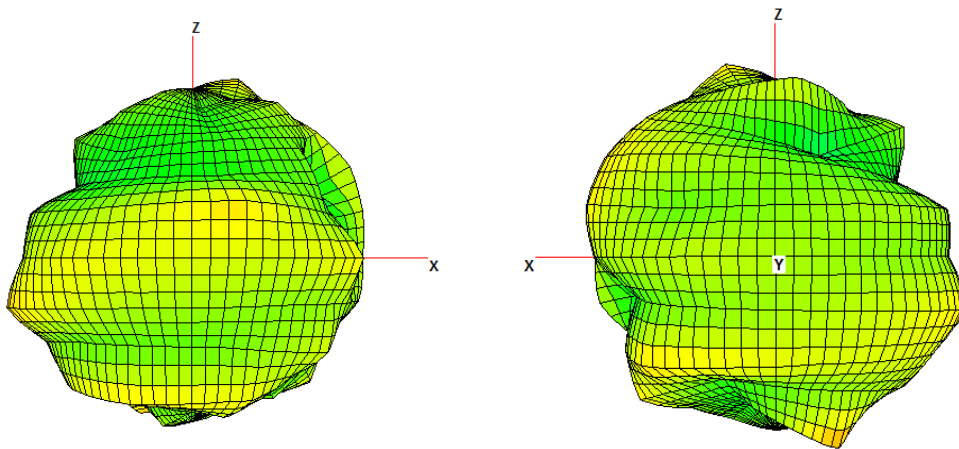

XZ-Plane

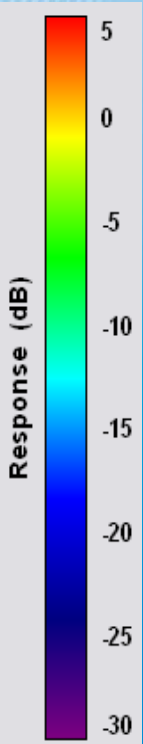
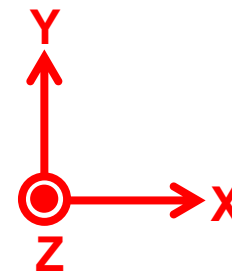

3D Radiation Pattern – Ant 4

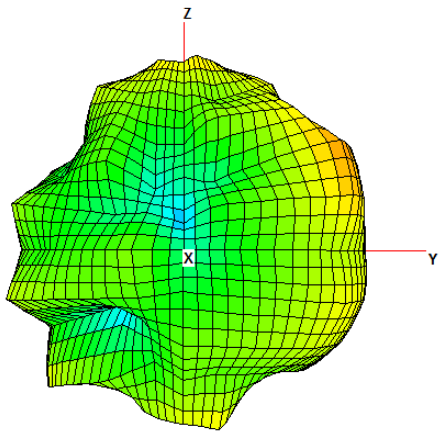
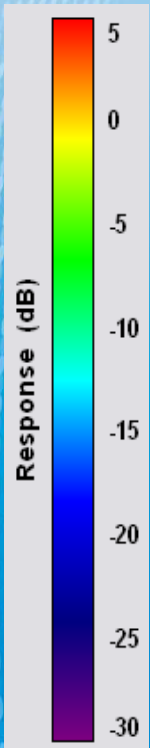

YZ-Plane

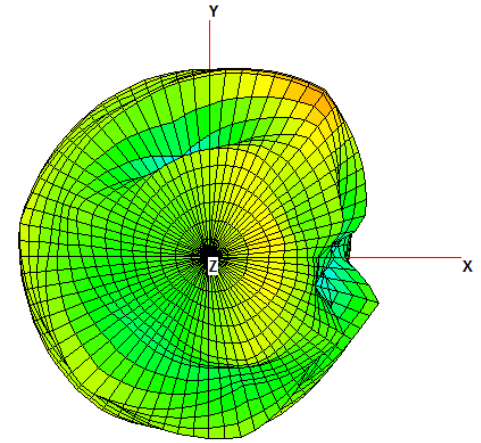
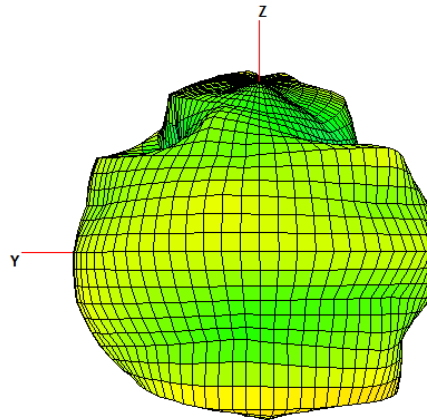

XY-Plane

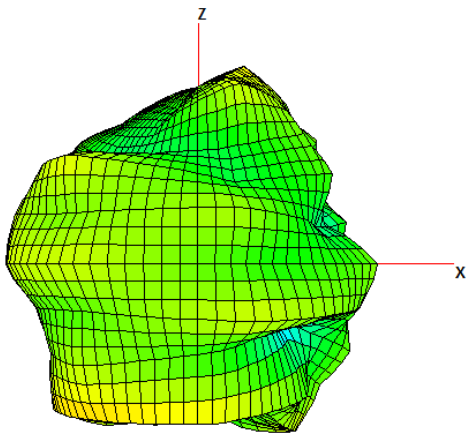

XZ-Plane

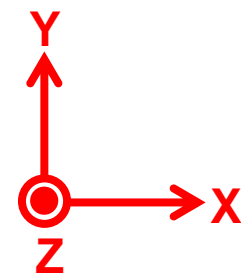
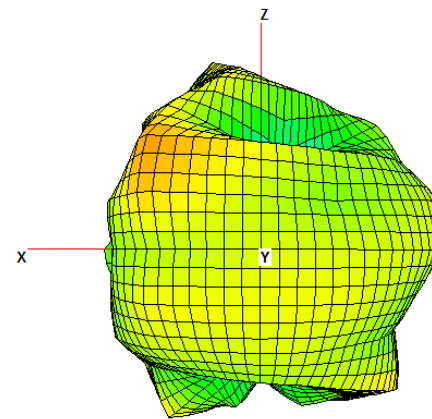

2D Radiation Pattern – WiFi 2.4G

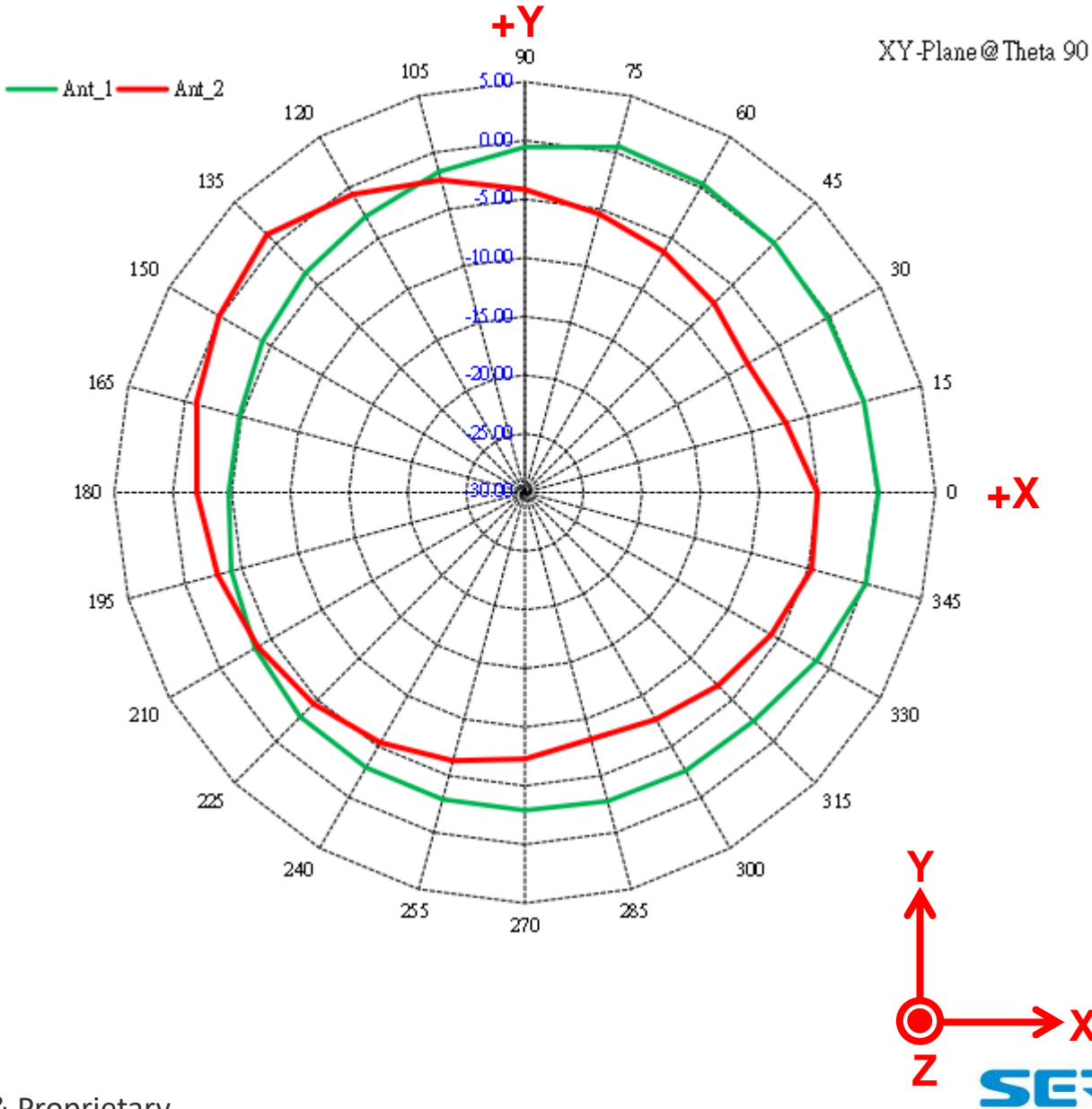

2D Radiation Pattern – WiFi 5G

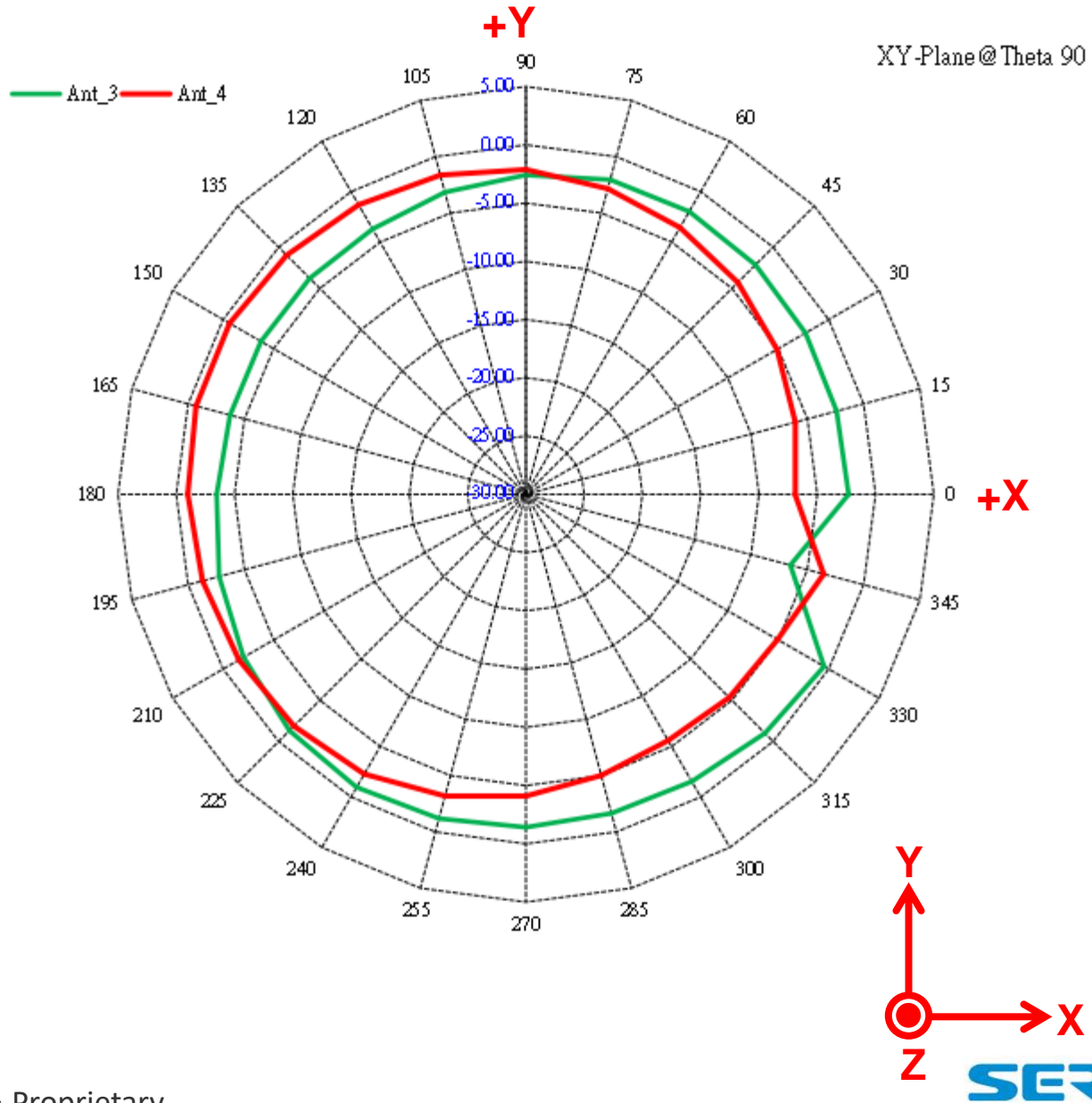

Peak Gain & Efficiency

Ant 1		
Frequency (MHz)	Peak Gain (dBi)	Efficiency (%)
2400	2.4	51
2450	2.6	53
2500	2.5	52

Ant 2		
Frequency (MHz)	Peak Gain (dBi)	Efficiency (%)
2400	2.6	60
2450	2.0	57
2500	2.1	57

Ant 3		
Frequency (MHz)	Peak Gain (dBi)	Efficiency (%)
5150	2.0	50
5550	2.3	52
5850	2.1	51

Ant 4		
Frequency (MHz)	Peak Gain (dBi)	Efficiency (%)
5150	2.6	60
5550	2.2	56
5850	2.1	50

SERCOMM

www.sercomm.com